

17. Remove the main pressure seal (205).



18. Remove the thrust washer (304) from the end cap (4) and shaft (2).



19. Remove the O-ring (304.1) from its groove in the end cap (4) and shaft (2).



20. Remove the outside diameter piston seal (202) from the piston.



21. Remove the inside diameter piston seal (200).



### Inspection

**NOTICE**

**PRIOR TO ASSEMBLY OF ACTUATOR, THESE STEPS MUST BE CLOSELY FOLLOWED TO ENSURE PROPER OPERATION OF THE ACTUATOR.**

1. Clean all parts in a solvent tank and dry with compressed air prior to inspecting.
2. Carefully inspect all critical areas for any surface finish abnormalities: Seal grooves, bearing grooves, thrust surfaces, shaft surface, housing bore and gear teeth.

**NOTICE**

**SMALL OR MINOR SURFACE SCRATCHES CAN BE CAREFULLY POLISHED.**

**Assembly**

1. Gather all the components and tools into one location prior to re-assembly. Use the cut away drawing to reference the seal orientations.



2. Coat the thrust washers (304) with a generous amount of Lithium grease. Install the thrust washer (304) onto shaft (2) and end cap (4).



3. Install the exclusion seal (304.1) into the appropriate grooves on the shaft (2) and end cap (4) around the outside edge of the thrust washer (304).



4. Using a seal tool install the main pressure seal (205) onto shaft (2) and end cap (4). Use the seal tool in a circular motion.



5. Install the wear guide (302) on the end cap (4) and shaft (2).



6. Install the O-ring (204) and back-up ring (207) into the inner seal groove on the end cap (4).



## SECTION 4 - BOOM & PLATFORM

7. Install the inner T-seal (200) into the appropriate groove in the piston (3). Use a circular motion to ensure the seal is correctly seated in the groove.

Install the outer T-seal (202) by stretching it around the groove in a circular motion.



Each T-seal has 2 back-up rings (see Assembly Drawing for orientation). Beginning with the inner seal (200) insert one end of backup ring in the lower groove and feed the rest in using a circular motion. Make sure the wedged ends overlap correctly.

Insert the other back up ring in upper groove.

Repeat both of these steps for the outer seal (202).



8. Insert the piston (3) into the housing (1) as shown, until the outer piston seal (202) contacts the inside housing bore.



9. Looking into the housing bore from the shaft flange end, rotate the piston (3) until the marks you put on the piston and the housing (1) during disassembly align as shown. Using a rubber mallet, tap the piston into the housing until the gear teeth contact.



10. Looking into the bore from the opposite end of the housing (1) be sure the timing marks align correctly. Rotate the piston as necessary until aligned, then gently tap the piston (3) into the housing until the gear teeth mesh together. Tap the piston into the housing until it completely bottoms out against the ring gear.



11. Insert the shaft (2) into the piston (3). Be careful not to damage the piston seals. Do not engage the piston gear teeth yet.

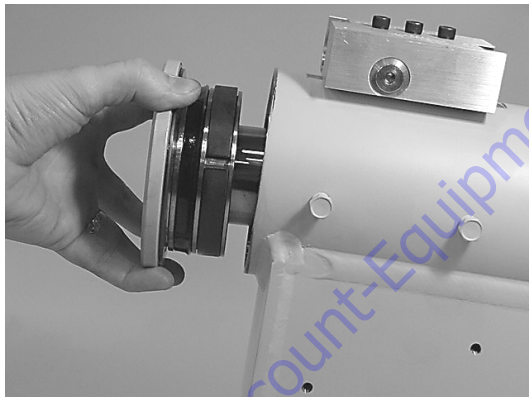

12. Looking at the actuator from the end opposite the shaft flange, use the existing timing marks to align the gear teeth on the shaft (2) with the gear teeth on the inside of the piston (3). When the marks align, gently tap the flange end of the shaft with a rubber mallet until the gear teeth engage.



13. Install two bolts in the threaded holes in the flange. Using a metal bar, rotate the shaft in a clockwise direction until the wear guides are seated inside the housing bore.

**NOTICE**

AS THE SHAFT IS ROTATED, BE CAREFUL NOT TO DISENGAGE THE PISTON AND HOUSING GEARING.

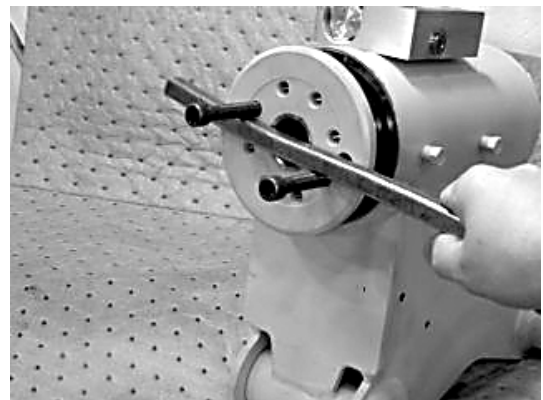

## SECTION 4 - BOOM & PLATFORM

- 14.** Install the stop tube (400) onto the shaft end if necessary. Stop tubes are an available option to limit the rotation of an actuator.



- 15.** Coat the threads on the end of the shaft with anti-seize grease to prevent galling.

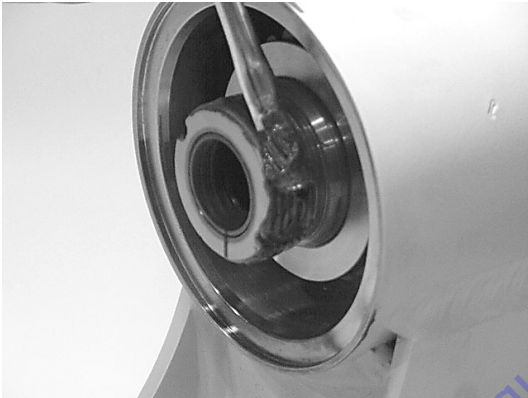

- 16.** Thread the end cap (4) onto the shaft (2). Make sure the wear guide remains in place on the end cap as it is threaded into the housing (1).



- 17.** Tighten the end cap (4) using a metal bar. In most cases the original holes for the lock pins will align.

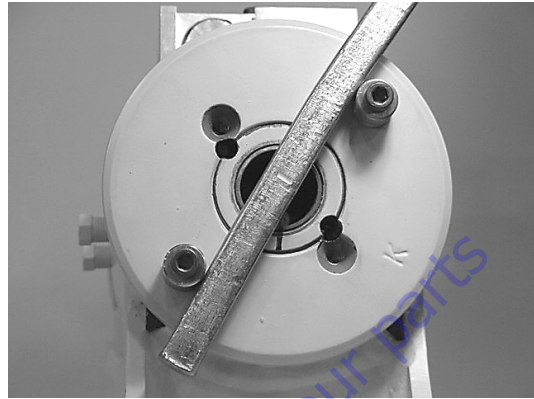

- 18.** Insert the lock pins (109) provided with the Helac seal kit into the holes with the dimple side up. Then, using a punch, tap the lock pins to the bottom of the hole.



- 19.** Insert the set screws (113) over the lock pins. Tighten to 25 in-lbs. (2.8 Nm).

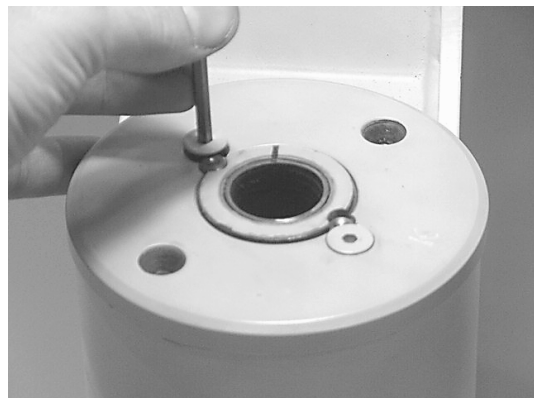

## Greasing Thrust Washers

1. After the actuator is assembled but before it is put into service, the thrust washer area must be packed with Lithium grease.

There are two grease ports located on both the shaft flange and the end cap. They are plugged with cap screws (113) or set screws. Remove the grease port screws from the shaft flange and end cap. (See exploded view)

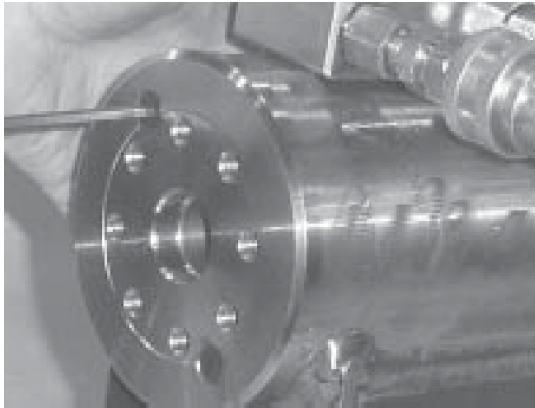

### NOTICE

**IF A HYDRAULIC TEST BENCH IS NOT AVAILABLE, THE ACTUATOR CAN BE ROTATED BY HAND, OPEN THE PRESSURE PORTS AND USE A PRY BAR WITH CAP SCREWS INSERTED INTO THE SHAFT FLANGE TO TURN THE SHAFT IN THE DESIRED DIRECTION.**

Insert the tip of a grease gun into one port and apply grease to the shaft flange. Continue applying until grease flows from the opposite port. Cycle the actuator five times and apply grease again. Repeat this process on the end cap. Insert the cap screws into the grease ports and tighten to 25 in-lbs. (2.8 Nm).

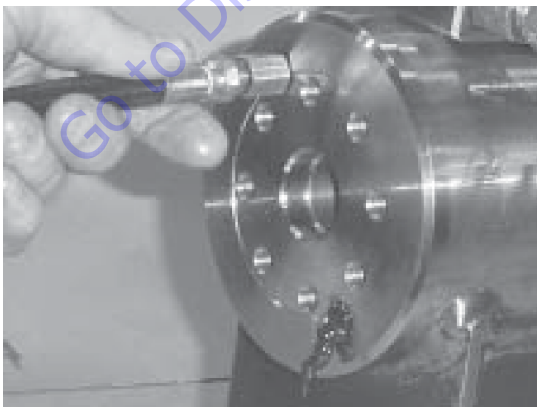

## Installing Counterbalance Valve

Refer to Figure 4-11., Rotator Counterbalance Valve.

1. Make sure the surface of the actuator is clean, free of any contamination and foreign debris including old Loctite.
2. Make sure the new valve has the O-rings in the counterbores of the valve to seal it to the actuator housing.
3. The bolts that come with the valve are grade 8 bolts. New bolts should be installed with a new valve. Loctite #242 should be applied to the shank of the three bolts at the time of installation.
4. Torque the 1/4-inch bolts 110 to 120 inch pounds (12.4 to 13.5 Nm). Do not torque over 125 inch pounds (14.1 Nm). Torque the 5/16-inch bolts 140 inch pounds (15.8 Nm). Do not torque over 145 inch pounds (16.3 Nm).

## Testing the Actuator

If the equipment is available, the actuator should be tested on a hydraulic test bench. The breakaway pressure — the pressure at which the shaft begins to rotate — should be approximately 400 psi (28 bar). Cycle the actuator at least 25 times at 3000 psi (210 bar) pressure. After the 25 rotations, increase the pressure to 4500 psi (315 bar) to check for leaks and cracks. Perform the test again at the end of the rotation in the opposite direction.

### TESTING THE ACTUATOR FOR INTERNAL LEAKAGE

If the actuator is equipped with a counterbalance valve, plug the valve ports. Connect the hydraulic lines to the housing ports. Bleed all air from the actuator (see Installation and Bleeding) Rotate the shaft to the end of rotation at 3000 psi (210 bar) and maintain pressure. Remove the hydraulic line from the non-pressurized side.

Continuous oil flow from the open housing port indicates internal leakage across the piston. Replace the line and rotate the shaft to the end of rotation in the opposite direction. Repeat the test procedure outlined above for the other port. If there is an internal leak, disassemble, inspect and repair.

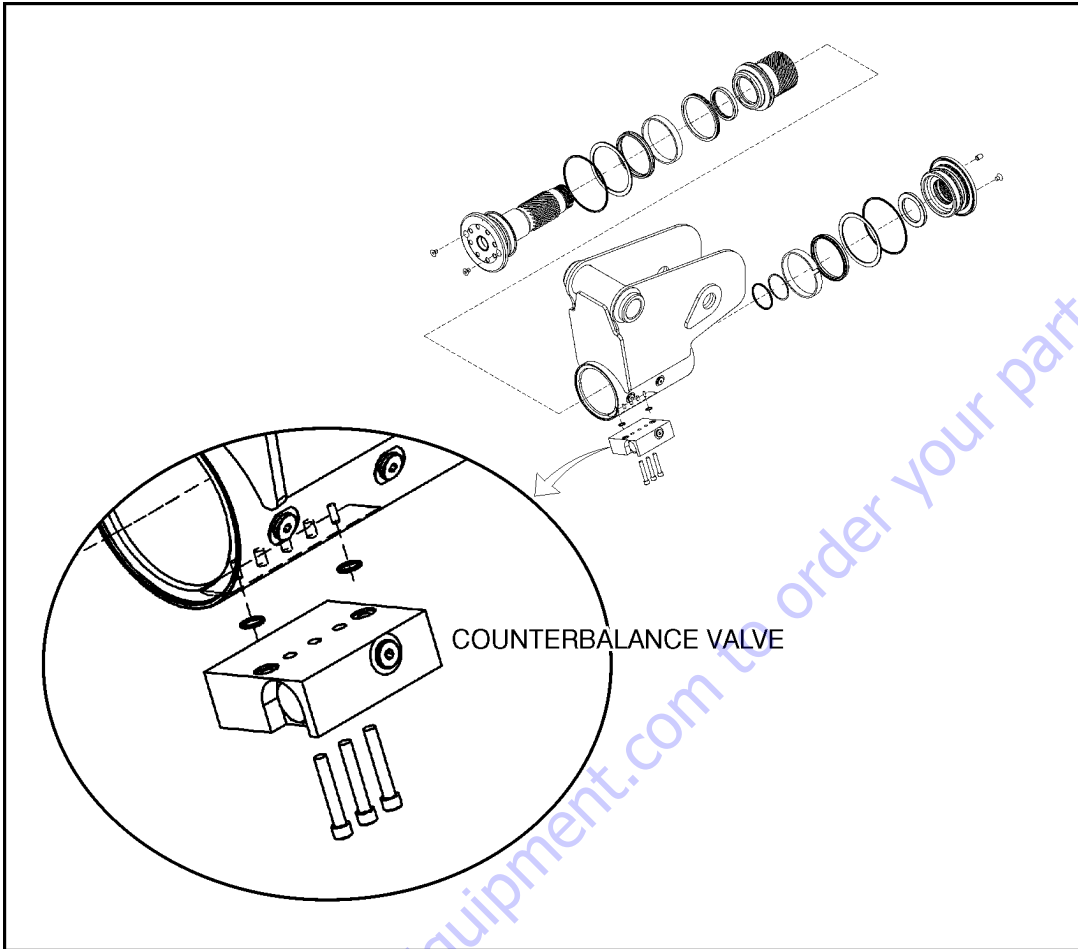

Figure 4-11. Rotator Counterbalance Valve

## Installation and Bleeding

After installation of the actuator on the equipment, it is important that all safety devices such as tie rods or safety cables are properly reattached.

To purge air from the hydraulic lines, connect them together to create a closed loop and pump hydraulic fluid through them. Review the hydraulic schematic to determine which hydraulic lines to connect. The linear feet and inside diameter of the hydraulic supply lines together with pump capacity will determine the amount of pumping time required to fully purge the hydraulic system.

Bleeding may be necessary if excessive backlash is exhibited after the actuator is connected to the hydraulic system. The following steps are recommended when a minimum of two gallons (8 liters) is purged.

1. Connect a 3/16" inside diameter x 5/16" outside diameter x 5 foot clear, vinyl drain tube to each of the two bleed nipples. Secure them with hose clamps. Place the vinyl tubes in a clean 5-gallon container to collect the purged oil. The oil can be returned to the reservoir after this procedure is completed.

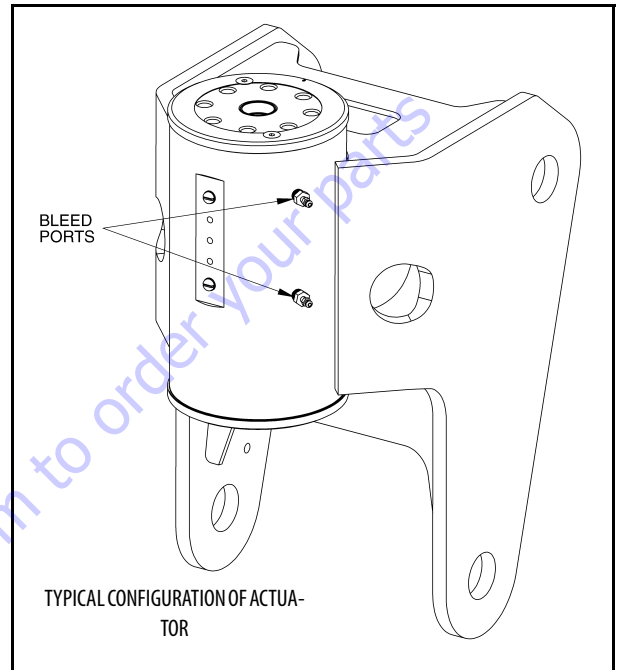

2. With an operator in the platform, open both bleed nipples 1/4 turn. Hydraulically rotate the platform to the end of rotation (either clockwise or counterclockwise), and maintain hydraulic pressure. Oil with small air bubbles will be seen flowing through the tubes. Allow a 1/2 gallon of fluid to be purged from the actuator.
3. Keep the fittings open and rotate the platform in the opposite direction to the end position. Maintain hydraulic pressure until an additional 1/4 gallon of fluid is pumped into the container.
4. Repeat steps 2 & 3. After the last 1/2 gallon is purged, close both bleed nipples before rotating away from the end position.



## Troubleshooting

Table 4-1. Troubleshooting

Problem	Cause	Solution
1. Shaft rotates slowly or not at all	<p>a. Insufficient torque output</p> <p>b. Low rate of fluid flow</p> <p>c. Control or counterbalance valve has internal leak</p> <p>d. Piston and/or shaft seal leak</p> <p>e. Corrosion build-up on the thrust surfaces</p> <p>f. Swollen seals and composite bearings caused by incompatible hydraulic fluid</p>	<p>a. Verify correct operating pressure. Do not exceed OEM's pressure specifications. Load may be above maximum capacity of the actuator.</p> <p>b. Inspect ports for obstructions and hydraulic lines for restrictions and leaks.</p> <p>c. Disconnect hydraulic lines and bypass valve. Leave valve ports open and operate the actuator through housing ports (do not exceed OEM's operating pressure). The valve must be replaced if a steady flow of fluid is seen coming from the valve ports.</p> <p>d. Remove the plug and the housing's valve ports. Operate the actuator through the housing ports. Conduct the internal leakage test as described in the Testing section on page 24 of this manual.</p> <p>e. Re-build the actuator. Remove all rust then polish. Replacement parts may be needed.</p> <p>f. Re-build the actuator. Use fluid that is compatible with seals and bearings.</p>
2. Operation is erratic or not responsive	a. Air in actuator	a. Purge air from actuator. See bleeding procedures.
3. Shaft will not fully rotate	<p>a. Twisted or chipped gear teeth</p> <p>b. Port fittings are obstructing the piston</p>	<p>a. Check for gear binding. Actuator may not be able to be rebuilt and may need to be replaced. Damage could be a result of overload or shock.</p> <p>b. Check thread length of port fittings. Fittings should during stroke not reach inside the housing bore.</p>
4. Selected position cannot be maintained	<p>a. Control or counterbalance valve has internal leak</p> <p>b. Piston and/or shaft seal leak</p> <p>c. Air in actuator</p>	<p>a. Disconnect hydraulic lines and bypass valve. Leave valve ports open and operate the actuator through housing ports (do not exceed OEM's operating pressure). The valve must be replaced if a steady flow of fluid is seen coming from the valve ports.</p> <p>b. Remove the plug and the housing's valve ports. Operate the actuator through the housing ports. Conduct the internal leakage test as described in the Testing section on page 24 of this manual.</p> <p>c. Purge air from actuator. See bleeding procedures</p>

## 4.9 SKYGUARD®

### Operation

SkyGuard provides enhanced control panel protection. When the SkyGuard sensor is activated, functions in use at the time of actuation will reverse or cutout. The SkyGuard Function Table provides more details on these functions.

Consult the following illustrations to determine which type of SkyGuard the machine is equipped with. Regardless of the type, SkyGuard function according to the SkyGuard Function Table does not change.

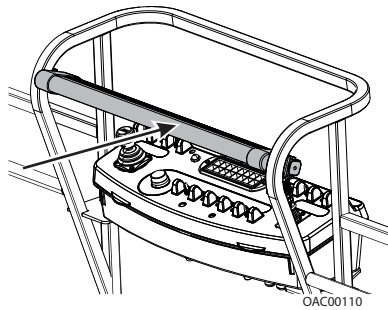

**SkyGuard**

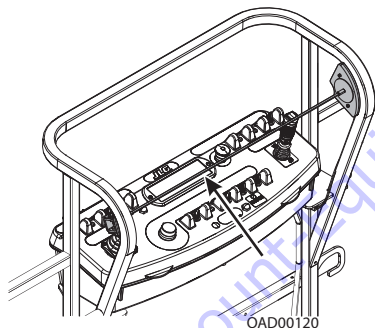

**SkyGuard SkyLine™**

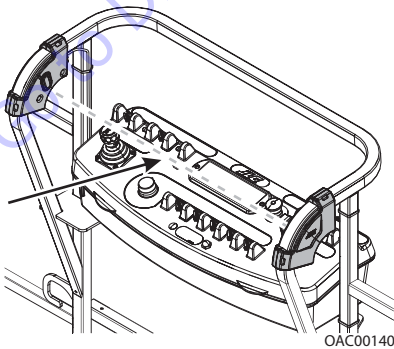

**SkyGuard SkyEye™**

### **⚠ WARNING**

**THE MACHINE OPERATOR IS REQUIRED TO PERFORM A DAILY FUNCTION TEST TO ENSURE PROPER OPERATION OF THE SKYGUARD SYSTEM.**

### Function Test

#### SKYGUARD ONLY

Perform this function test if **SkyGuard only** is selected in machine setup (refer to Table 6-7).

*From the Platform Control Console in an area free from obstructions:*

1. Operate the telescope out function, then activate SkyGuard sensor.
2. Once sensor has been activated, ensure telescope out function stops then telescope in function operates for a short duration. Additionally, verify Soft Touch/SkyGuard indicator light flashes and horn sounds. If machine is equipped with SkyGuard beacon, ensure it flashes when sensor activates.
3. With SkyGuard sensor still engaged, press and hold yellow Soft Touch/SkyGuard override button. Operate a function to verify operation can be resumed.
4. Disengage SkyGuard sensor, release controls, and recycle footswitch. Ensure normal operation available.

*In Ground Mode:*

1. Operation is allowed regardless of SkyGuard activation.

#### SOFT TOUCH ONLY

If **Soft Touch only** is selected in machine setup (refer to Table 6-7), machine will treat the Soft Touch/SkyGuard override switch as if it is a Soft Touch switch.

#### SKYGUARD NOT SELECTED IN MACHINE SETUP

If the SkyGuard system is installed on the machine, but no option is selected in the machine setup (refer to Table 6-7), SkyGuard sensor status will be ignored. No function cutout or reversal will be implemented.

**Diagnostics & Troubleshooting**

If SkyGuard does not function when the sensor is engaged, first verify the configuration under the MACHINE SETUP: SKYGUARD OPTION menu using the handheld Analyzer. Ensure the selected configuration matches the actual system installed on the machine. If not, select the correct configuration, then verify operation.

Additionally, use the handheld analyzer to navigate to the DIAGNOSTICS: FEATURES → SKYGUARD INPUTS menu to determine additional SkyGuard fault information.

Engage the SkyGuard sensor and observe the Analyzer to determine if the switch/relay closes.

If the status of the switch/relay remains OPEN while the SkyGuard sensor is actively engaged, it is possible the sensor has failed and should be replaced immediately.

If the status of the switch/relay remains CLOSED while the SkyGuard sensor is actively engaged, a power or ground wire may not be making good contact or may be loose or broken. Additionally, there is a low probability that both relays may have failed.

If the switch/relay status is in disagreement, then one may have failed or is not installed correctly. In this case, the machine will be inoperable.

**FAULT CODES**

Refer to Table 6-14 for more fault code information

- **0039** - SkyGuard switch activation fault
- **2563** - switch disagreement fault

**Table 4-2. SkyGuard Function Table**

Drive Forward	Drive Reverse	Steer	Swing	Tower Lift Up	Tower Lift Down	Boom Lift Up	Boom Lift Down	Boom Tele Out	Boom Tele In	Jib Lift	Basket Level	Basket Rotate
R*/C**	R	C	R	R	C	R	R	R	C	C	C	C
R= Indicates Reversal is Activated												
C= Indicates Cutout is Activated												
* DOS (Drive Orientation System) Enabled												
** DOS Not Enabled, machine is driving straight without steering, and any other hydraulic function is active												

# PARTS FINDER

**Search Website  
by Part Number**



**Search Manual  
Library For Parts  
Manual & Lookup Part  
Numbers – Purchase  
or Request Quote**

A screenshot of the "Search Manuals" form. It includes fields for "Brand", "Serial Number", "Model", "Part Number", and "Category". There is a "Search" button at the bottom.

**Can't Find Part or  
Manual? Request Help  
by Manufacturer,  
Model & Description**

A screenshot of the "Parts Order Form". It is a form with several sections: "Manufacturer", "Model", "Description", "Part Number", "Quantity", "Price", and "Comments". There are input fields for each section and a "Submit" button at the bottom.

Discount-Equipment.com is your online resource for quality parts & equipment.

Florida: **561-964-4949** Outside Florida TOLL FREE: **877-690-3101**

**Need parts?**

Click on this link: <http://www.discount-equipment.com/category/5443-parts/> and choose one of the options to help get the right parts and equipment you are looking for. Please have the machine model and serial number available in order to help us get you the correct parts. If you don't find the part on the website or on once of the online manuals, please fill out the request form and one of our experienced staff members will get back to you with a quote for the right part that your machine needs.

We sell worldwide for the brands: Genie, Terex, JLG, MultiQuip, Mikasa, Essick, Whiteman, Mayco, Toro Stone, Diamond Products, Generac Magnum, Airman, Haulotte, Barreto, Power Blanket, Nifty Lift, Atlas Copco, Chicago Pneumatic, Allmand, Miller Curber, Skyjack, Lull, Skytrak, Tsurumi, Husquvarna Target, , Stow, Wacker, Sakai, Mi-T- M, Sullair, Basic, Dynapac, MBW, Weber, Bartell, Bennar Newman, Haulotte, Ditch Runner, Menegotti, Morrison, Contec, Buddy, Crown, Edco, Wyco, Bomag, Laymor, Barreto, EZ Trench, Bil-Jax, F.S. Curtis, Gehl Pavers, Heli, Honda, ICS/PowerGrit, IHI, Partner, Imer, Clipper, MMD, Koshin, Rice, CH&E, General Equipment, ,AMida, Coleman, NAC, Gradall, Square Shooter, Kent, Stanley, Tamco, Toku, Hatz, Kohler, Robin, Wisconsin, Northrock, Oztec, Toker TK, Rol-Air, Small Line, Wanco, Yanmar

## SECTION 5. BASIC HYDRAULIC INFORMATION &amp; SCHEMATICS

## 5.1 LUBRICATING O-RINGS IN THE HYDRAULIC SYSTEM

When assembling connectors in the hydraulic that use o-ring fittings, it is necessary to lubricate all fittings with hydraulic oil prior to assembly. To lubricate the fittings, use one of the following procedures.

**NOTE:** All O-ring fittings must be pre-lubricated with hydraulic oil prior to assembly.

## Cup and Brush

The following is needed to correctly oil the o-ring in this manner:

- A small container for hydraulic oil
- Small paint brush



1. Hold the fitting in one hand while using the brush with the other hand to dip into the container. Remove excess hydraulic oil from the brush so an even film of oil is applied on the o-ring.



2. Holding the fitting over the hydraulic oil container, brush an even film of oil around the entire o-ring in the fitting, making sure the entire o-ring is completely saturated.



3. Turn the o-ring on the other side of the fitting and repeat the previous step, ensuring the entire o-ring is coated with hydraulic oil.



### Dip Method

**NOTE:** This method works best with Face Seal o-rings, but will work for all o-ring fitting types.

The following is needed to correctly oil the o-ring in this manner:

- A small leak proof container
  - Sponge cut to fit inside the container
  - A small amount of hydraulic oil to saturate the sponge.
1. Place the sponge inside the container and add hydraulic oil to the sponge until it is fully saturated.
  2. Dip the fitting into the sponge using firm pressure. Upon lifting the fitting, a small droplet will form and drip from the bottom of the fitting. This should signify an even coating of oil on the fitting.



3. O-ring Boss type fittings will require more pressure in able to immerse more of the fitting into the saturated sponge. This will also cause more oil to be dispersed from the sponge.



### Spray Method

This method requires a pump or trigger spray bottle.

1. Fill the spray bottle with hydraulic oil.
2. Hold the fitting over a suitable catch can.
3. Spray the entire o-ring surface with a medium coat of oil.



### Brush-on Method

This method requires a sealed bottle brush.

1. Fill the bottle with hydraulic oil.
2. Using slight pressure to the body of the spray bottle, invert the bottle so the brush end is in the downward position.
3. Brush hydraulic oil on the entire o-ring, applying an even coat of oil.



## 5.2 HYDRAULIC CYLINDERS

Holding (counterbalance) valves are used in the Lift, Level, Jib, Telescope, and Axle Lockout circuits to prevent retraction of the cylinder rod should a hydraulic line rupture or a leak develop between the cylinder and its' related holding valve.

**NOTE:** The steer cylinder weighs approximately 37.2 lbs (16.9 kg).

**NOTE:** The tower lift cylinder weighs approximately 76 lbs (34.5 kg).

**NOTE:** The upper lift cylinder weighs approximately 97 lbs (44 kg).

**NOTE:** The master cylinder weighs approximately 35.3 lbs (16 kg).

**NOTE:** The level cylinder weighs approximately 37.4 lbs (17 kg).

**NOTE:** The jib lift cylinder weighs approximately 55 lbs (25 kg).

**NOTE:** The telescope cylinder weighs approximately 52.7 lbs (23.9 kg).

**NOTE:** The axle oscillation lockout cylinder weighs approximately 26.2 lbs(11.9 kg).

### Disassembly and Assembly Instructions

1. Make sure the work area is large enough for the entire cylinder and clean and free of dirt. Ensure the cylinder can be secured firmly in place during disassembly.

2. Prepare all the necessary tools and replacement parts. Refer to Table 5-2, Required Tools.

### General Information

1. Clean any burrs or contamination from the surface of the cylinder before disassembly.
2. Handle every part with care. Each part is precision made and hitting parts together or letting them fall could damage the machined surfaces.
3. Do not twist or strike parts to get them apart. This will damage the part and/or threads, resulting in leakage and poor function.
4. Do not let the cylinder in a disassembled condition for a long period of time. It only takes a short period of time for the parts to rust.

### Standard of Maintenance

Parts and seals should be replaced according to the conditions as follows.

1. Bushings - 1/4 of the bushing is worn off.
2. Seal and Slide Ring - Replace during disassembly.
3. Pin Bushing - When it is worn down.
4. Rod - Bent or warped more than 0.5mm/1m.

### Inspection After Assembly

Table 5-1. Inspection After Assembly

Operation Inspection Without Load	There is no problem when fully extended 5 times without load						
Dimension	Check the retracted length and stroke						
Inspection of the Surface	When each of the cylinders are pressurized with test pressure on the piston end, it should not be loose and have no change in pressure or external leakage						
Inspection of external leakage	Check the oil leakage at the rod area. Refer to Figure 5-1., Acceptable Oil Leakage on Cylinder Rod.						
Inspection of internal leakage	Leakage Unit: ml/ 10 minutes						
	Bore (mm)	Leakage (ml)	Bore (mm)	Leakage (ml)	Bore (mm)	Leakage (ml)	Remark
	32	0.4	100	4	160	10	
	40	0.6	125	5.6	180	12.6	
	50	1	140	6	200	15.6	
	63	1.6			220	20	
	80	2.3			250	22	

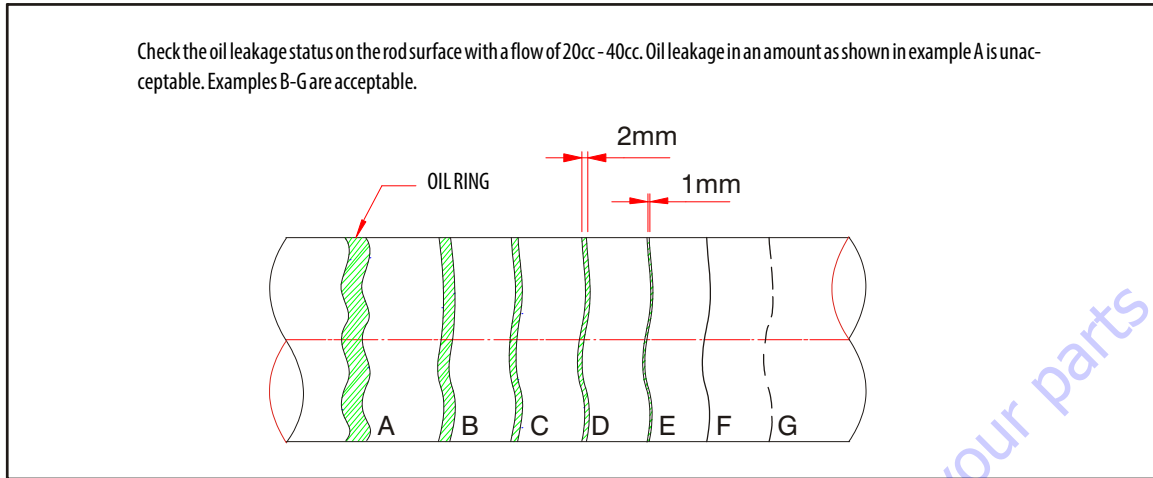

**Figure 5-1. Acceptable Oil Leakage on Cylinder Rod**

Go to Discount-Equipment.com to order your parts



Table 5-2. Required Tools





Item No.	Description	Quantity
1	 Flat-head Screwdriver	1
2	 Allen Wrench Set	1 Set
3	 Vise	1
4	 Spanner Wrench	1 Set
5	 Punch	1
6	 Torque Wrench	1 Set
7	 Plastic Hammer	1
8	 Crescent Wrench	1
9	 Hera (Seal Disassembly)	

Table 5-3. Special Tools

Name of Tool	Description
Bushing for Disassembly	
Bushing for Press	
MRP Bearing Disassembly	
MRP Bearing Press	
Dust Wiper Press/ Dust Wiper Insert	
Gland Seal Protection (Gland Guide Jig)	
Piston Seal Protection (Piston Guide Jig)	

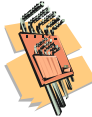
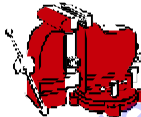
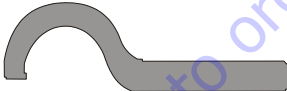
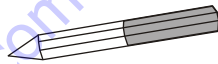
### Disassembly Procedure

1. Remove the oil from the cylinder.
2. Fix the cylinder in a vertical or horizontal position. Vertical position is convenient for disassembly and assembly. Fix the base by inserting the pin not to be rotated. Remove any hoses, valves, or fittings that may be in the way.

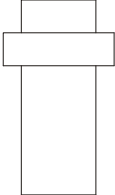
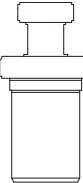
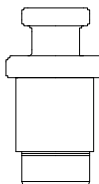
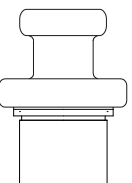
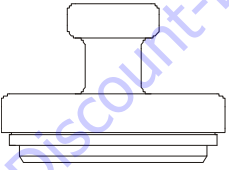
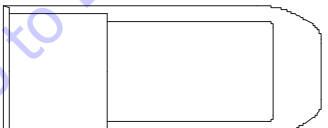
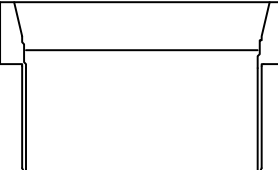
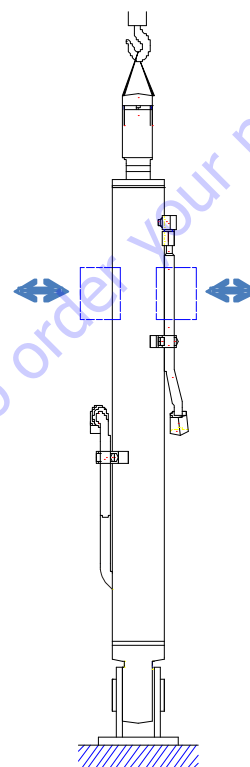

3. Unscrew the cylinder Head

Glands that are threaded into the barrel are locked in place with caulking. Using a spanner wrench, unscrew the gland from the barrel. (It is easier to do this with rod pulled out 5cm from the gland). If there is no caulking, continue with the disassembly process.

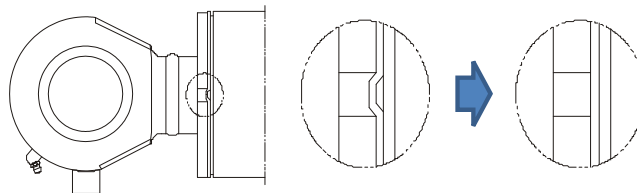

4. Remove the Rod assembly
  - a. Check if the cap or plug has been removed from the cylinder ports.
  - b. Place a suitable container under the cylinder to catch any oil coming out of the cylinder.

- c. After the Rod assembly is pulled from the barrel, unscrew the head using a spanner wrench.

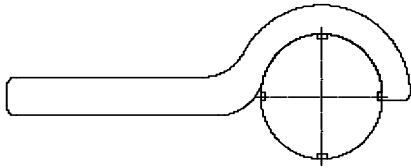

- d. After disassembling the rod assembly, place it on a support.

**⚠ CAUTION**

IF THE CYLINDER IS AT A VERTICAL POSITION FOR DISASSEMBLY, GIVE ATTENTION TO THE FOLLOWING; WHEN THE HEAD IS UNSCREWED AND THE ROD ASSEMBLY IS PULLED FROM THE BARREL, THERE IS A SPACE BETWEEN THE HEAD AND PISTON. IT IS POSSIBLE FOR THE HEAD TO SUDDENLY SLIDE DOWN, POSSIBLY CAUSING INJURY. TO PREVENT THIS, THE HEAD SHOULD BE PUSHED AGAINST THE PISTON BEFORE PROCEEDING.

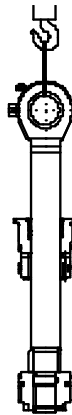

**⚠ CAUTION**

IF A CYLINDER IS AT A HORIZONTAL POSITION FOR DISASSEMBLY, GIVE ATTENTION TO THE FOLLOWING; IT IS POSSIBLE FOR THE ROD TO FALL AND BE DAMAGED WHEN REMOVED FROM THE BARREL IF NOT PROPERLY SUPPORTED. PLACE SUPPORT UNDER THE BARREL AS SHOWN BELOW.

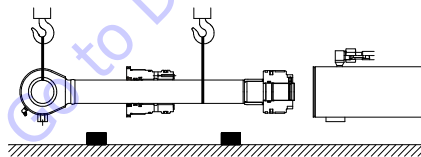

- 5. Place the Rod assembly on blocking as shown below. Use the pin hole to keep it from rotating.

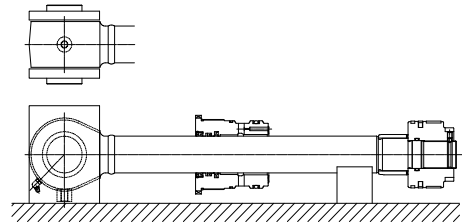

- 6. Unscrew the Piston Nut.

- a. Unscrew the set screw. Caulking is used to lock the setscrew so grind the caulking area and then unscrew the set screw.

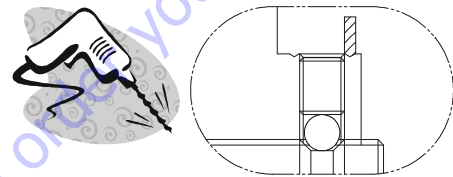

- b. Remove the steel ball

- c. Unscrew the piston nut. The piston nut is secured with a torque specified in Table 5-4, Piston Nut Torque. 1.5 x this torque is needed to remove the nut. If the stronger torque is needed, use a power wrench operated by a hydraulic unit

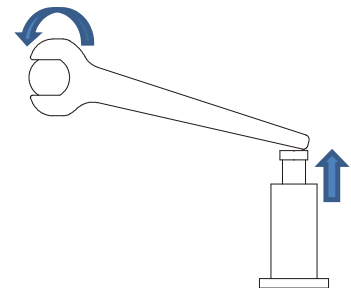

**NOTE:** If it is not a set screw type, continue with the disassembly of the piston nut.

- 7. Remove the PISTON NUT, PISTON and GLAND in sequence.

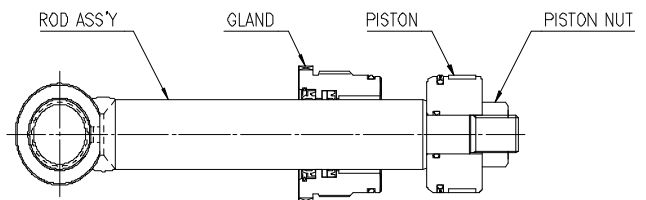

**8. Piston nut, piston, gland disassembly.**

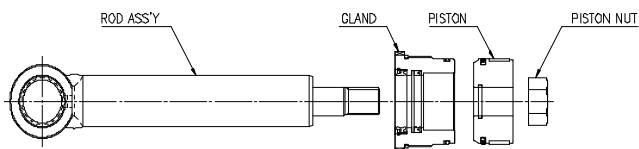

- a. Unscrew the Piston Nut.
- b. Take the piston apart by sliding off the rod in the direction of the rod threads.
- c. Take the gland apart by sliding off the rod in the direction of the rod threads.

**9. Take apart piston seals.**

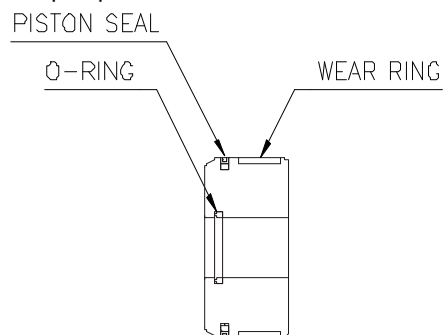

- a. The wear ring is easily taken apart by hand.
- b. The piston seal is a two piece seal; the ring at the outer side is easily removed. Remove the ring inside of the piston seal.
- c. Remove the o-ring.

**NOTE:** All seals must be discarded after removal. They can not be reused.

**10. Remove the gland seal.**

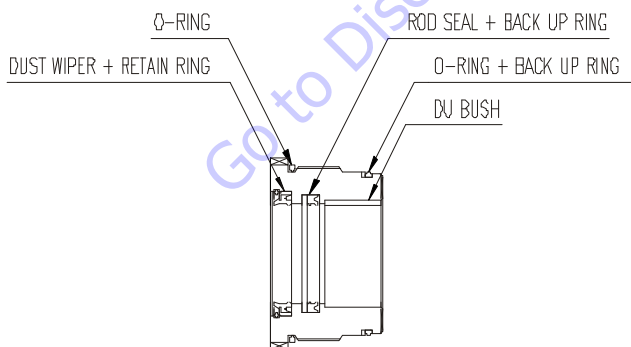

- a. Remove the rod seal and backup ring.
- b. Remove the retaining ring with a flat-head screwdriver prior to removing the dust wiper and remove the dust wiper.
- c. Remove the o-ring and backup ring.

- d. The du bushing is pressed in and must be removed by using a tool as shown below.

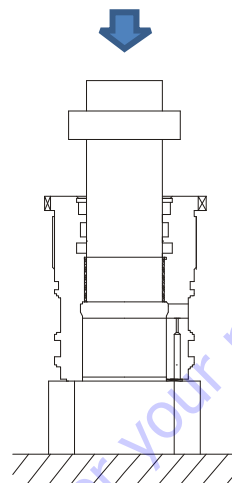

**NOTICE**

**DISCARD ALL SEALS AFTER REMOVAL AND REPLACE THEM WITH NEW ONES FOR ASSEMBLY.**

**11. MRP BEARING DISASSEMBLY**

To remove the MRP bearing, break it into pieces.

**12. WASHING AND STORAGE**

All removed parts should be washed with cleaning solution and then coated with light oil to prevent rust. If the cylinder is not to be reassembled right away, store the parts and put a covering over them.

**Assembly**

**⚠ CAUTION**

**TAKE CARE NOT TO LET ANY PAINT CHIPS OR DIRT FALL INSIDE THE CYLINDER. THIS COULD CAUSE LEAKAGE.**

**1. Pin bushing assembly**

Coat the opening with oil to aid in assembly and press the bushing into the rod as shown below.

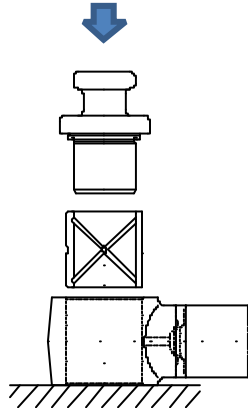

**2. Gland seal assemblies**

**a.** Coat the opening with oil to aid in assembly and press the bushing into place with the proper tool.

**b.** Rod seal assembly (Keep the right direction and do not make damage to seal)

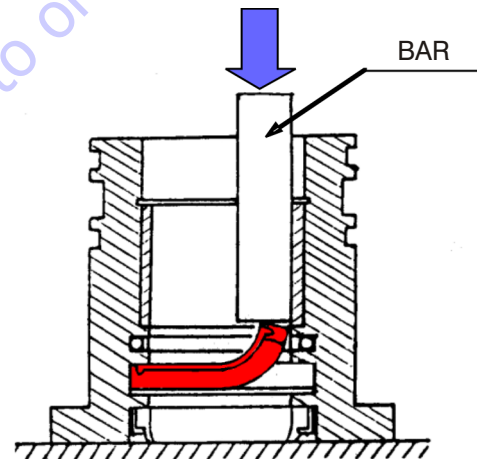
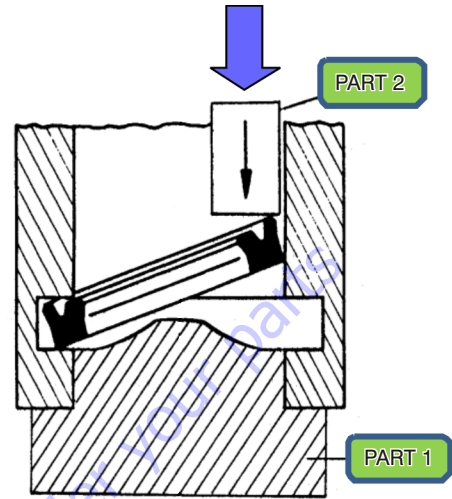

Go to Discount-Equipment.com to order your parts

- c. Install du bushing assembly and dust wiper assembly as shown below.

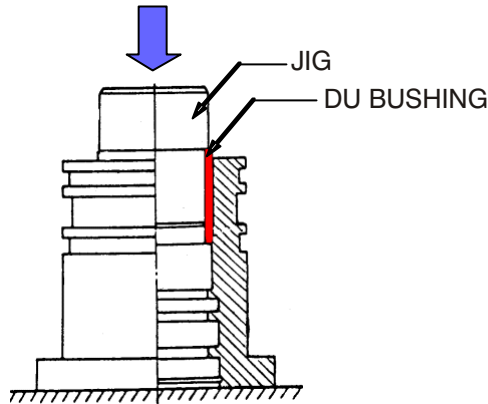
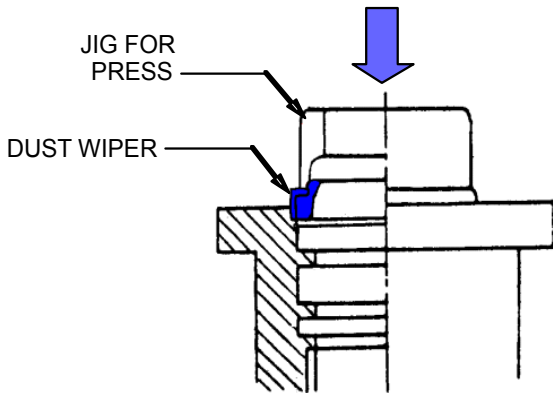

- d. Assemble back up ring, o-ring (Check the sequence of back up ring, o-ring.)

**3. Piston Seal Assembly**

- a. Assembly the seal assembly.  
b. Install the o-ring into the groove.

- c. Using a proper tool, press the piston seal onto the piston. When installing the piston seal, it is stretched while passing over the head.

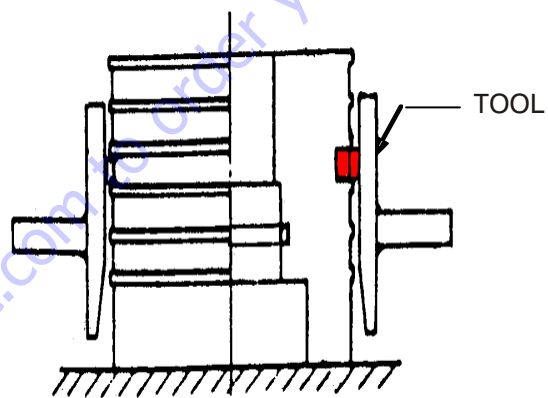
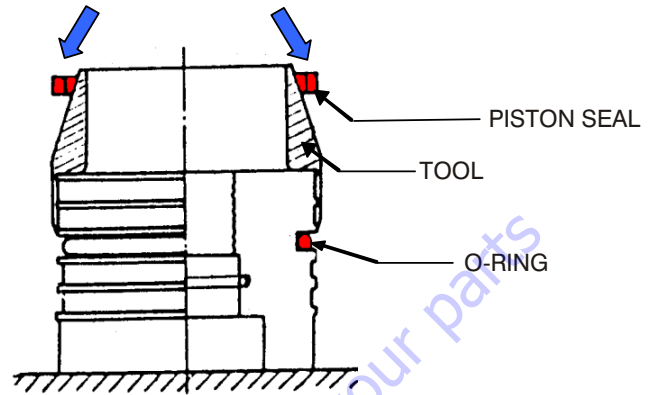

- d. Install the wear ring assembly by spreading it apart.

**4. Rod assembly**

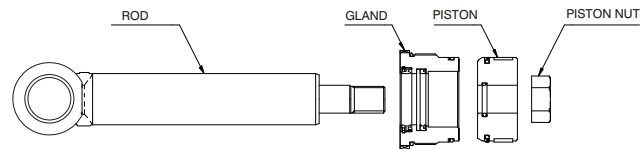

- a. Secure the rod assembly.  
b. Install the Head onto the rod assembly. Take care as not to damage the lip of the dust wiper and rod seal.

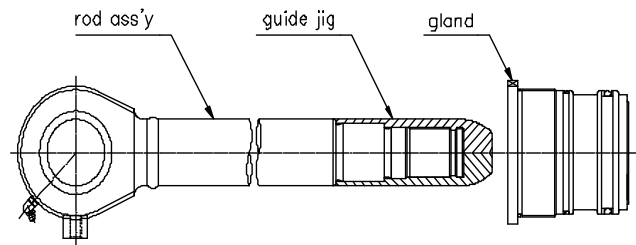

- c. Assemble Piston.

- d. Torque the Piston nut as specified in Table 5-4, Piston Nut Torque. Lack of the torque can result in internal leakage, the piston coming unscrewed, and thread damage. If overtorqued, the piston surface which meets the rod will be damaged.

**Table 5-4. Piston Nut Torque**

CYLINDER	PISTON
STEERING	NA
TOWERLIFT	267 ft.lbs.
UPPER LIFT	528 ft.lbs.
MASTER	267 ft.lbs.
LEVEL	267 ft.lbs.
JIB	267 ft.lbs.
TELESCOPE	267 ft.lbs.
RAM LOCK	NA

5. Assemble the rod assembly.
  - a. Secure the barrel at a vertical or horizontal position.
  - b. Insert the assembly into the barrel.
  - c. When piston is inserted to the barrel take care as to not damage the seal rings.

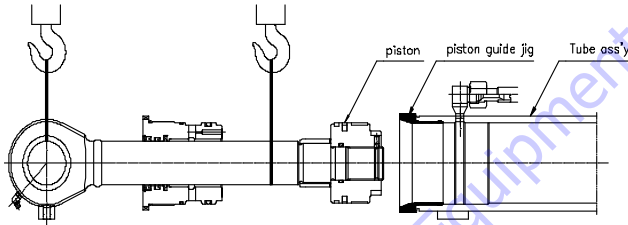

**6. Gland assembly.**

Install the gland using a spanner wrench as shown below

**Table 5-5. Gland Torque**

CYLINDER	GLAND
STEERING	397 ft.lbs.
TOWERLIFT	463 ft.lbs.
UPPER LIFT	550 ft.lbs.
MASTER	463 ft.lbs.
LEVEL	463 ft.lbs.
JIB	405 ft.lbs.
TELESCOPE	318 ft.lbs.
RAM LOCK	NA

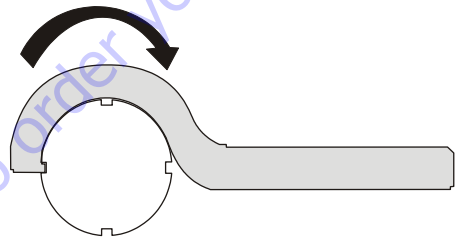

**7. Caulking.**

Caulk at the machined area of the cylinder barrel end so that it locks the cylinder head in place and it does not unscrew from the barrel. If there is no caulking hole, caulking is not necessary.

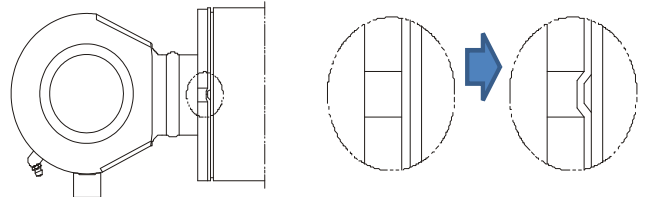

**8. Test operation.**

- a. Install the cylinder on a machine. Fill the cylinder with oil and then have the cylinder slowly operated a minimum of 8 cycles. If it is operated too fast in the beginning, cavitation will result. It is important to make sure all air is cycled from the cylinder.
- b. Grease the end of the pin.

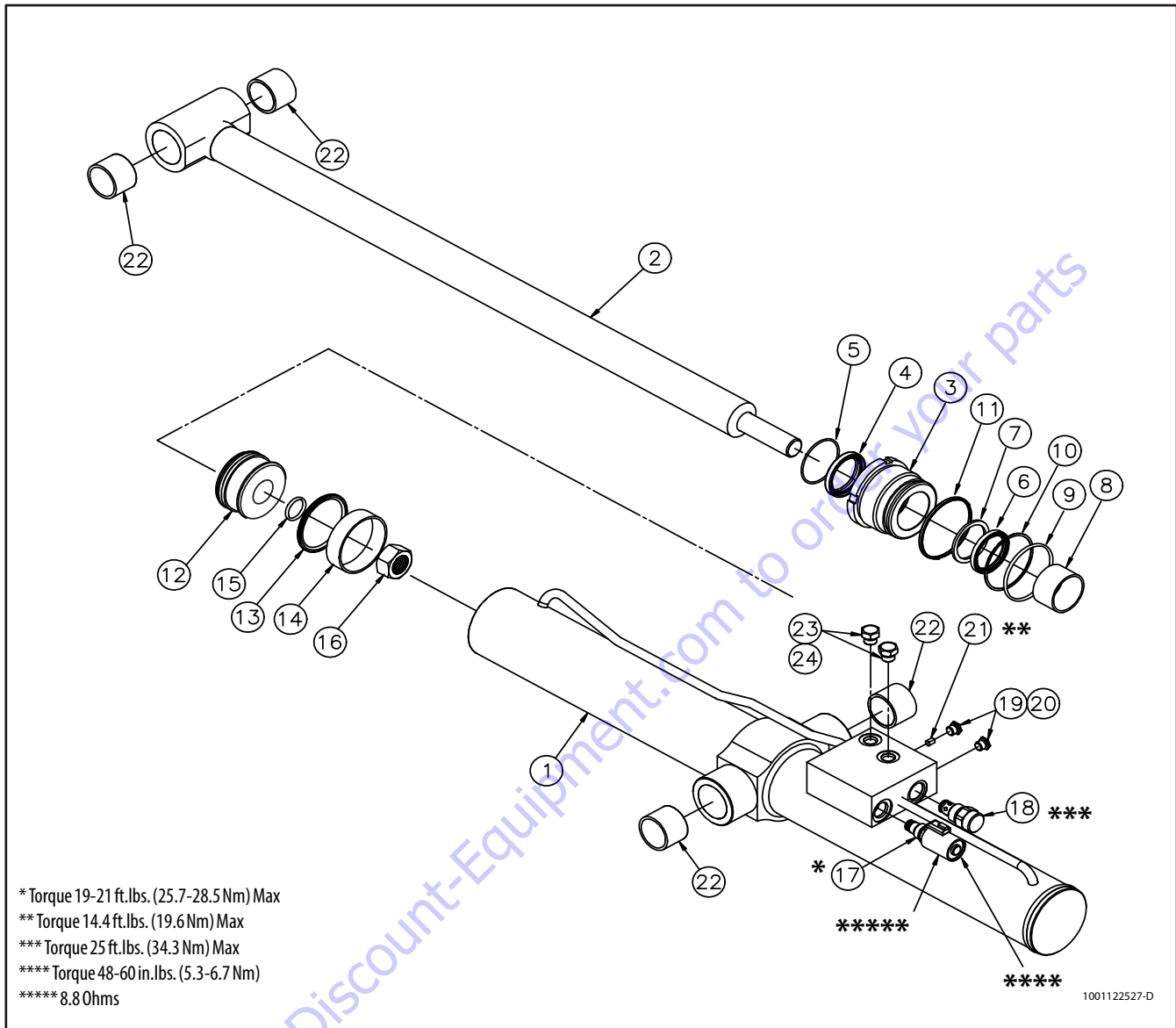

- |                   |                 |                 |                  |                 |
|-------------------|-----------------|-----------------|------------------|-----------------|
| 1. Tube           | 6. Rod Seal     | 11. O-ring      | 16. Nut          | 21. Orifice     |
| 2. Rod            | 7. Backup Ring  | 12. Piston      | 17. Poppet Valve | 22. MPR Bearing |
| 3. Gland          | 8. Dry Bearing  | 13. Piston Seal | 18. Check Valve  | 23. Plug        |
| 4. Dust Wiper     | 9. O-ring       | 14. Wear Ring   | 19. Plug         | 24. O-ring      |
| 5. Retaining Ring | 10. Backup Ring | 15. O-ring      | 20. O-ring       |                 |

Figure 5-2. Tower Lift Cylinder



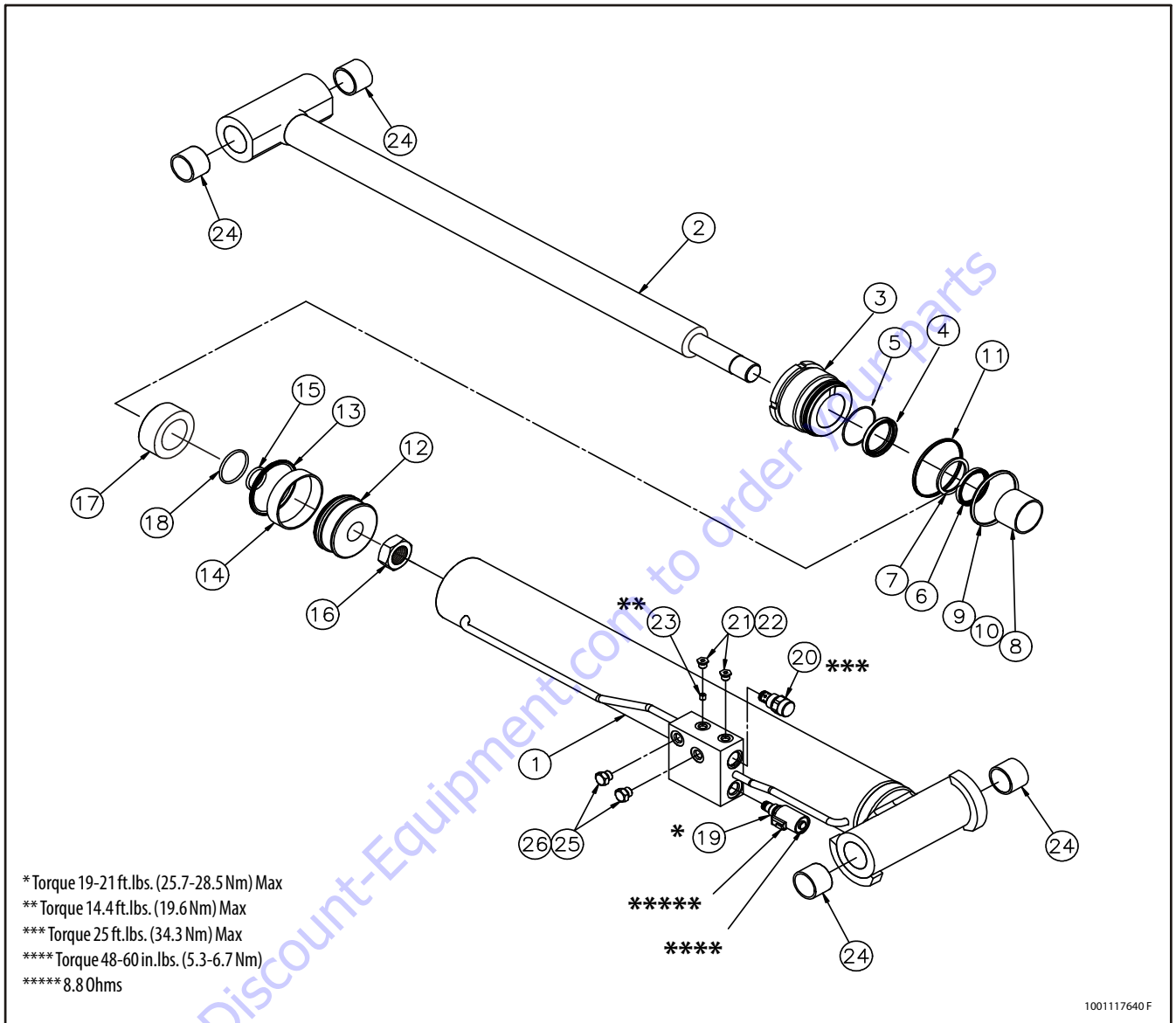

- |                   |                 |                 |                  |                 |
|-------------------|-----------------|-----------------|------------------|-----------------|
| 1. Tube           | 7. Backup Ring  | 12. Piston      | 17. Spacer       | 22. O-ring      |
| 2. Rod            | 8. Dry Bearing  | 13. Piston Seal | 18. O-ring       | 23. Orifice     |
| 3. Gland          | 9. O-ring       | 14. Wear Ring   | 19. Poppet Valve | 24. MPR Bearing |
| 4. Dust Wiper     | 10. Backup Ring | 15. O-ring      | 20. Check Valve  | 25. Plug        |
| 5. Retaining Ring | 11. O-ring      | 16. Nut         | 21. Plug         | 26. O-ring      |
| 6. Rod Seal       |                 |                 |                  |                 |

Figure 5-3. Upper Lift Cylinder

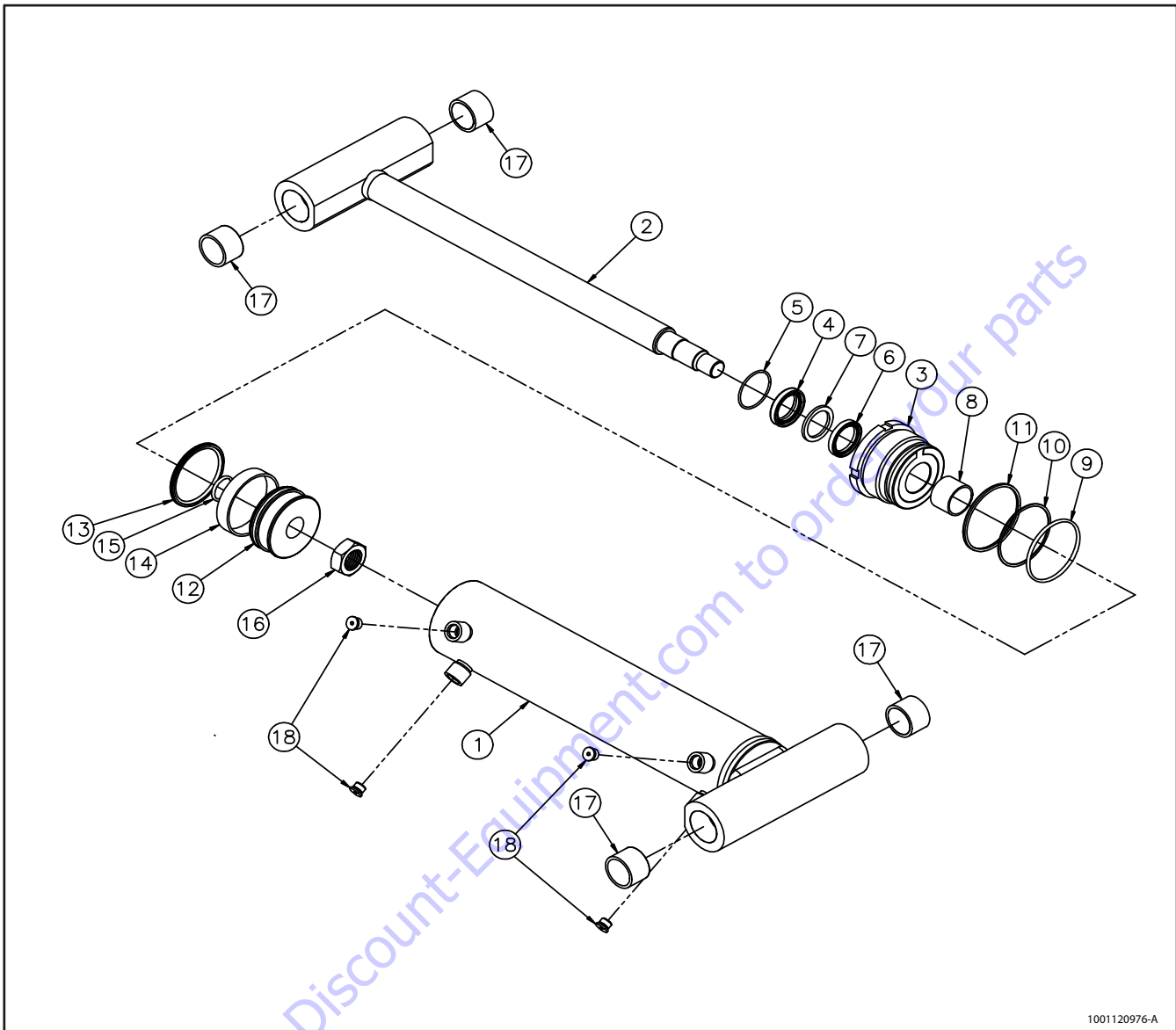

1001120976-A

- |                   |                 |                 |                 |
|-------------------|-----------------|-----------------|-----------------|
| 1. Tube           | 6. Rod Seal     | 11. O-ring      | 16. Nut         |
| 2. Rod            | 7. Backup Ring  | 12. Piston      | 17. MRP Bearing |
| 3. Gland          | 8. Dry Bearing  | 13. Piston Seal | 18. Plug        |
| 4. Dust Wiper     | 9. O-ring       | 14. Wear Ring   |                 |
| 5. Retaining Ring | 10. Backup Ring | 15. O-ring      |                 |

Figure 5-4. Master Cylinder

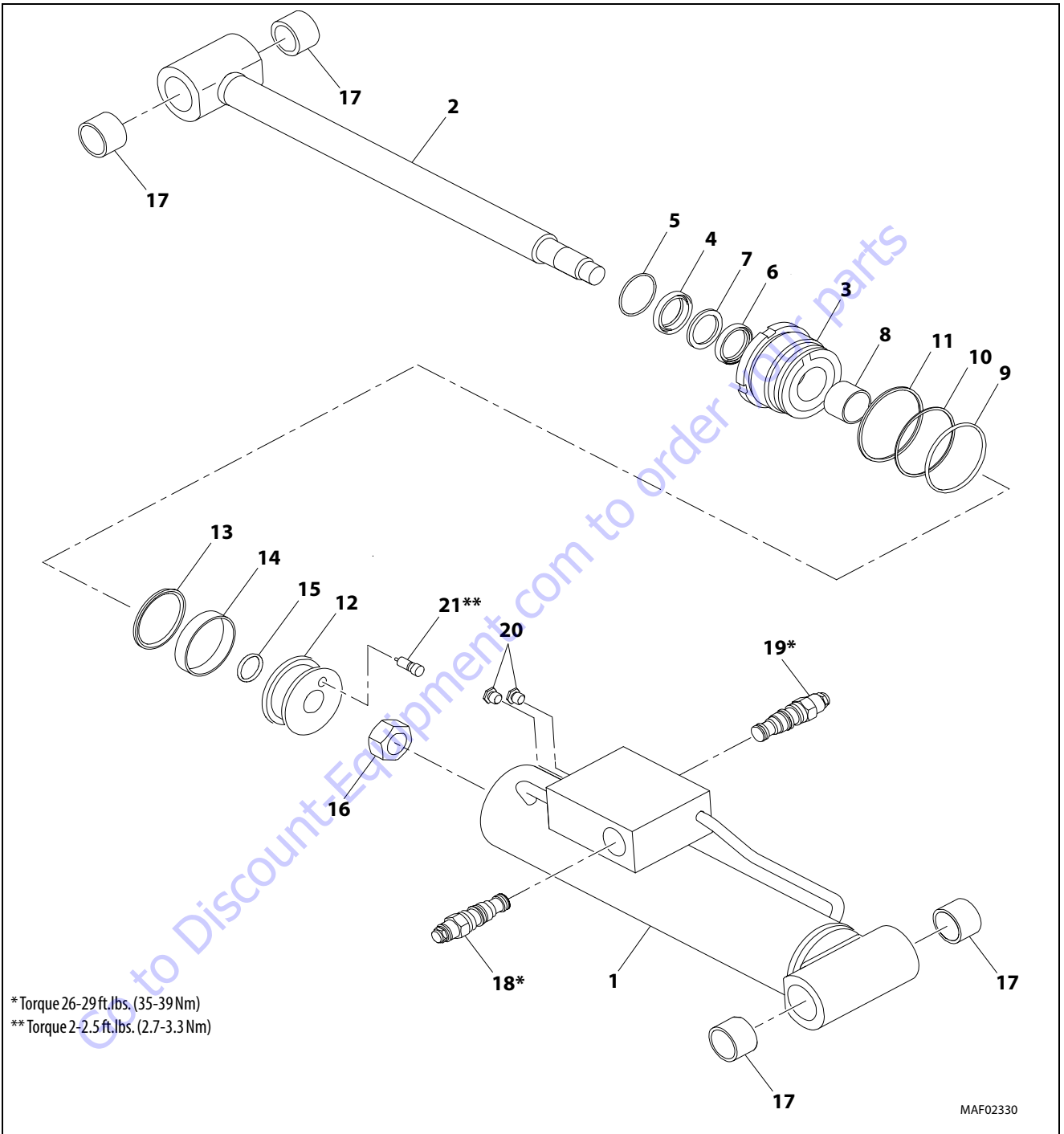

- |                   |                |                 |               |                     |
|-------------------|----------------|-----------------|---------------|---------------------|
| 1. Barrel         | 6. Rod Seal    | 10. Backup Ring | 14. Wear Ring | 18. Cartridge Valve |
| 2. Rod            | 7. Backup Ring | 11. O-Ring      | 15. O-Ring    | 19. Cartridge Valve |
| 3. Cylinder Head  | 8. Bearing     | 12. Piston      | 16. Nut       | 20. Plug            |
| 4. Wiper Seal     | 9. O-Ring      | 13. Piston Seal | 17. Bushing   | 21. Phase Valve     |
| 5. Retaining Ring |                |                 |               |                     |

Figure 5-5. Level Cylinder (Prior to SN 0300238046)

**SECTION 5 - BASIC HYDRAULIC INFORMATION & SCHEMATICS**

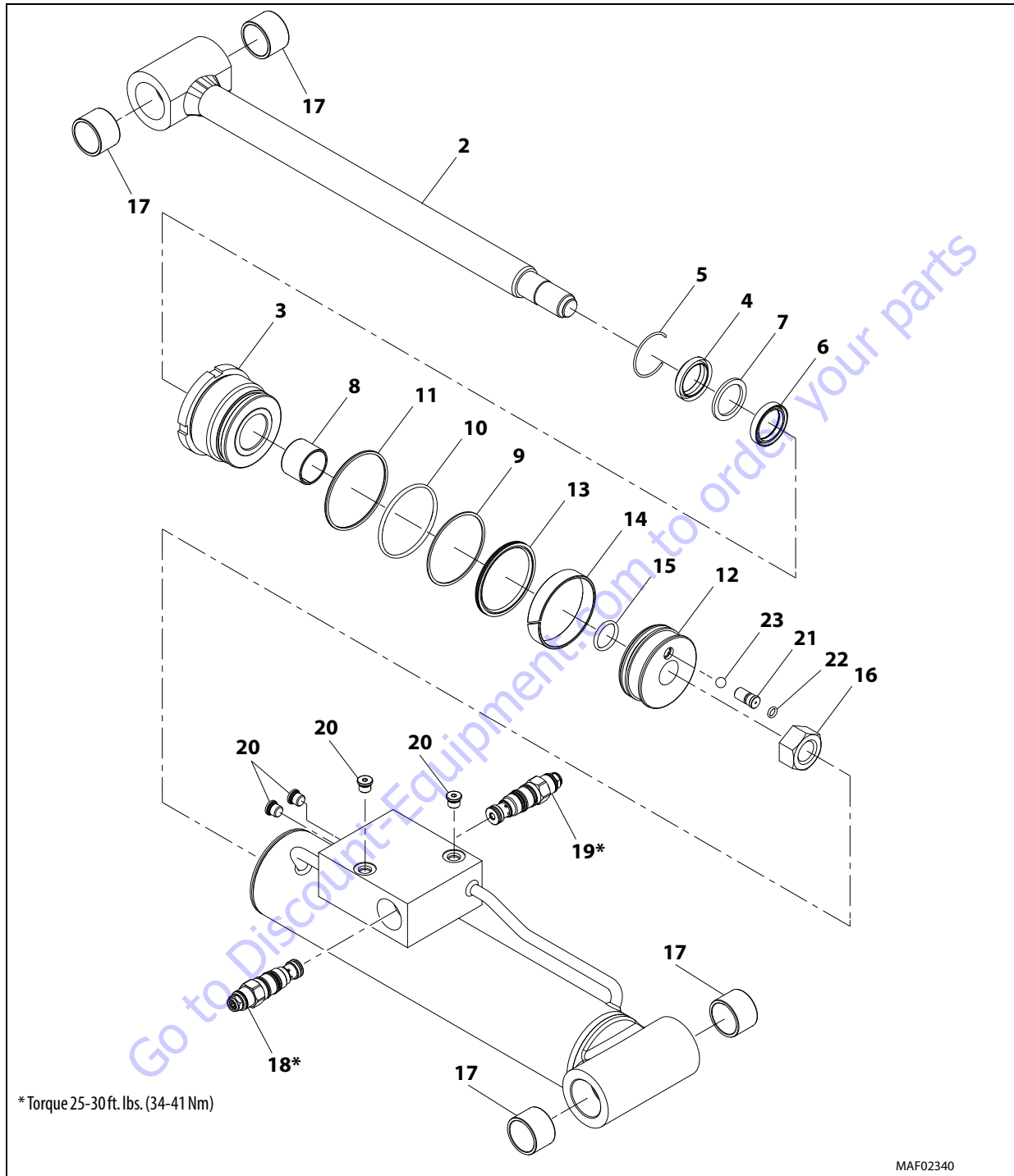

- |                   |                 |                 |                     |                |
|-------------------|-----------------|-----------------|---------------------|----------------|
| 1. Barrel         | 6. Rod Seal     | 11. O-Ring      | 16. Nut             | 20. Plug       |
| 2. Rod            | 7. Backup Ring  | 12. Piston      | 17. Bushing         | 21. Valve Seat |
| 3. Cylinder Head  | 8. Bearing      | 13. Piston Seal | 18. Cartridge Valve | 22. O-Ring     |
| 4. Wiper Seal     | 9. O-Ring       | 14. Wear Ring   | 19. Cartridge Valve | 23. Steel Ball |
| 5. Retaining Ring | 10. Backup Ring | 15. Wear Ring   |                     |                |

**Figure 5-6. Level Cylinder (SN 0300238046 to Present)**

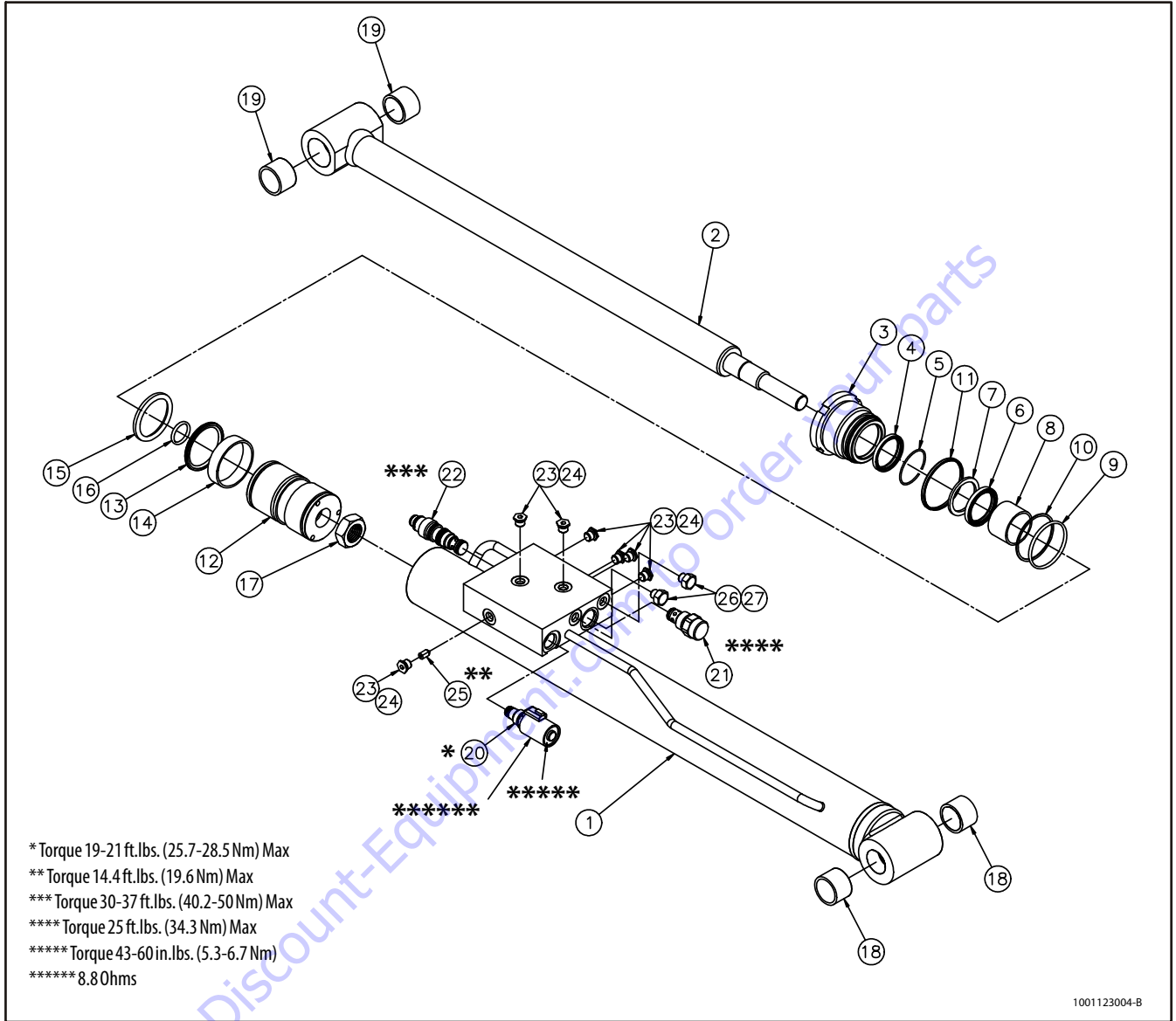

- |                   |                 |                 |                          |             |
|-------------------|-----------------|-----------------|--------------------------|-------------|
| 1. Tube           | 7. Backup Ring  | 13. Piston Seal | 19. MRP Bearing          | 25. Orifice |
| 2. Rod            | 8. Dry Bearing  | 14. Wear Ring   | 20. Poppet Valve         | 26. Plug    |
| 3. Gland          | 9. O-ring       | 15. O-ring      | 21. Check Valve          | 27. O-ring  |
| 4. Dust Wiper     | 10. Backup Ring | 16. Piston Ring | 22. Counterbalance Valve |             |
| 5. Retaining Ring | 11. O-ring      | 17. Hex Nut     | 23. Plug                 |             |
| 6. Rod Seal       | 12. Piston      | 18. MRP Bearing | 24. O-ring               |             |

Figure 5-7. Jib Cylinder

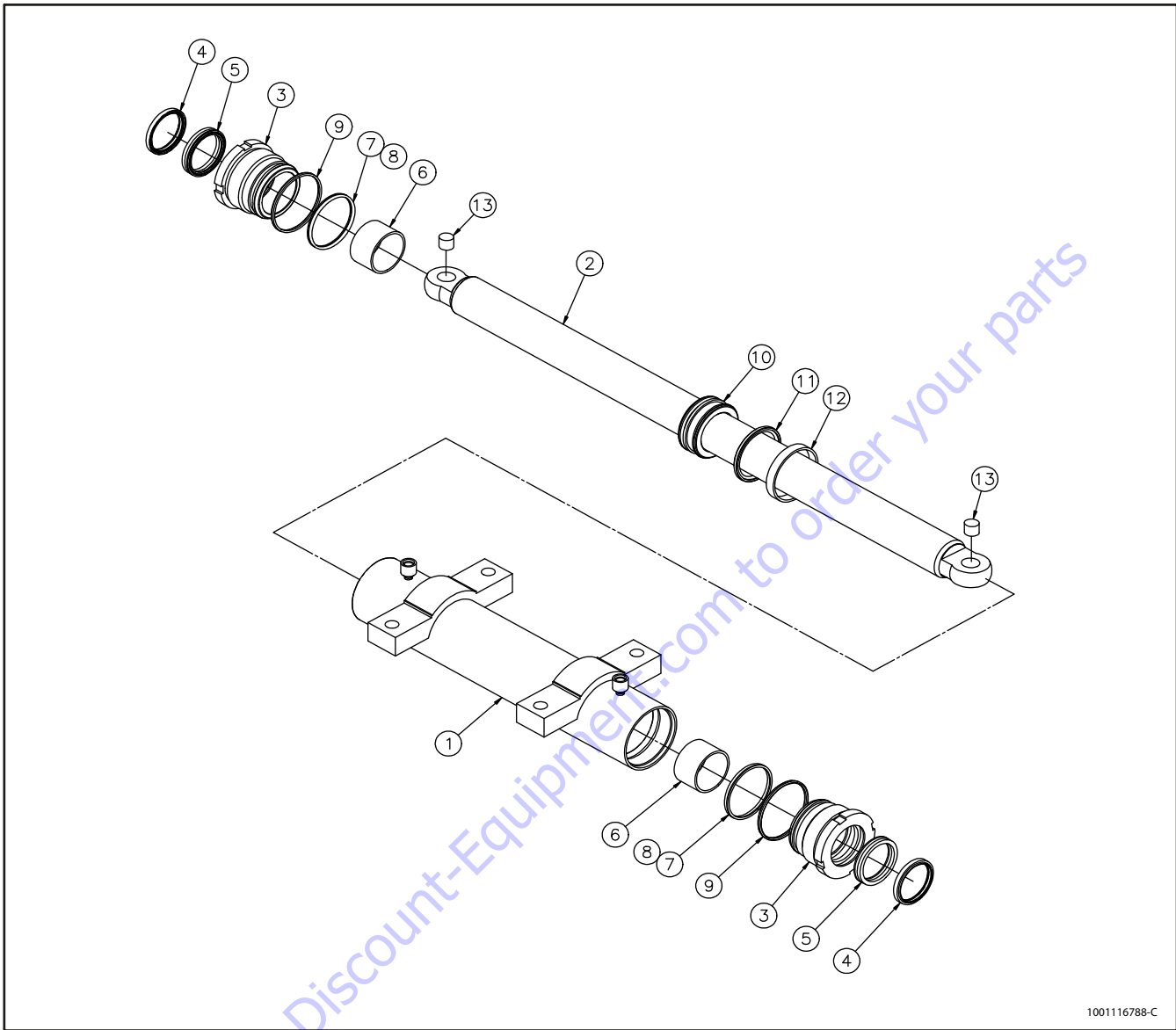

1001116788-C

- |               |                |                 |
|---------------|----------------|-----------------|
| 1. Tube       | 6. Rod Seal    | 11. Wear Ring   |
| 2. Rod        | 7. Dry Bearing | 12. Piston Seal |
| 3. Piston     | 8. O-ring      | 13. MRP Bearing |
| 4. Gland      | 9. Backup Ring |                 |
| 5. Dust Wiper | 10. O-ring     |                 |

Figure 5-8. Steer Cylinder

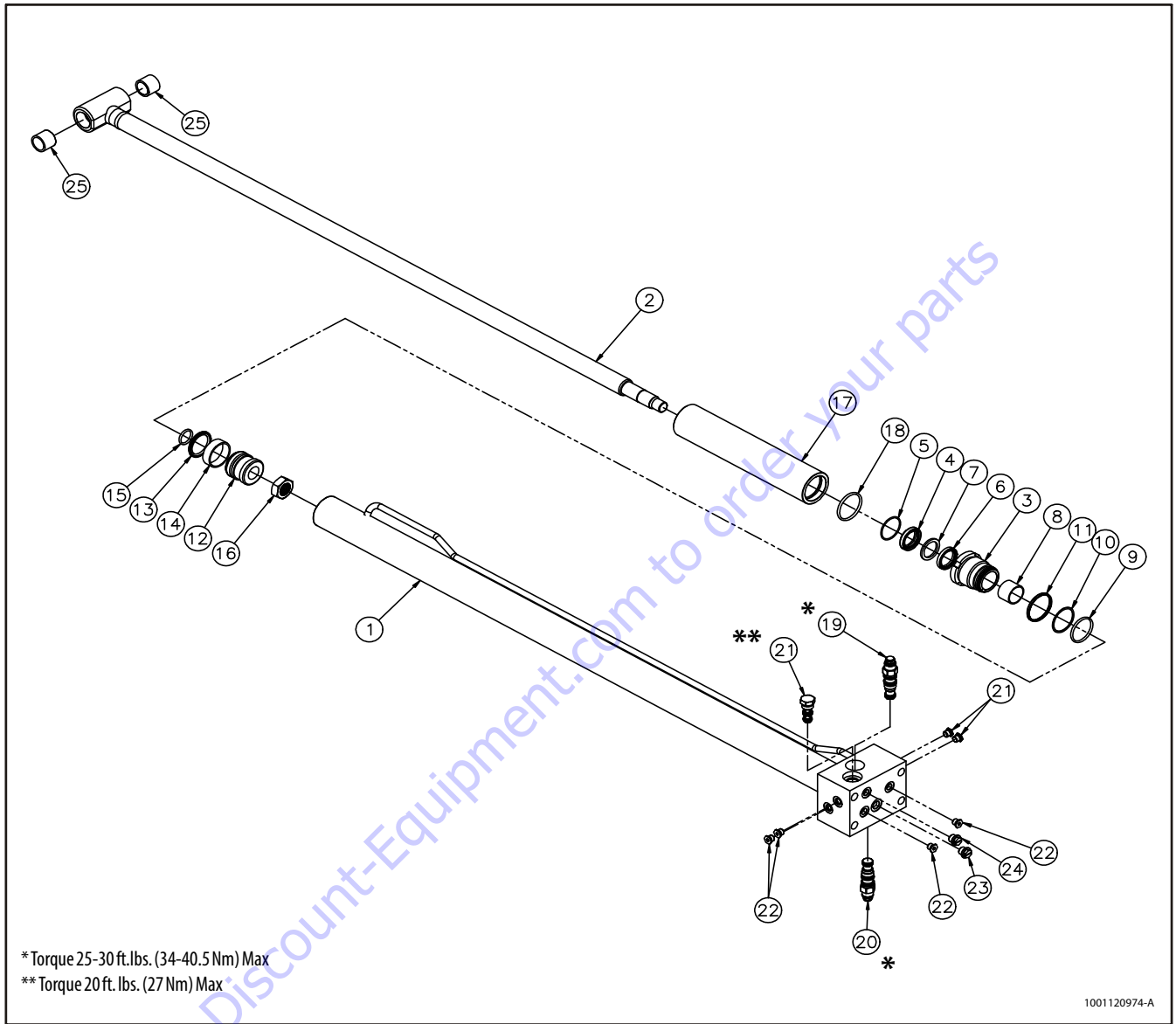

\*Torque 25-30 ft.lbs. (34-40.5Nm) Max  
 \*\*Torque 20 ft. lbs. (27Nm) Max

1001120974-A

- |                   |                 |                 |                          |                        |
|-------------------|-----------------|-----------------|--------------------------|------------------------|
| 1. Tube Assembly  | 6. Rod Seal     | 11. O-ring      | 16. Hex Nut              | 21. Load Shuttle Valve |
| 2. Rod            | 7. Backup Ring  | 12. Piston      | 17. Spacer               | 22. Plug               |
| 3. Gland          | 8. Dry Bearing  | 13. Piston Seal | 18. O-ring               | 23. Plug               |
| 4. Dust Wiper     | 9. O-ring       | 14. Wear Ring   | 19. Counterbalance Valve | 24. Plug               |
| 5. Retaining Ring | 10. Backup Ring | 15. O-ring      | 20. Counterbalance Valve | 25. MRP Bearing        |

Figure 5-9. Telescope Cylinder

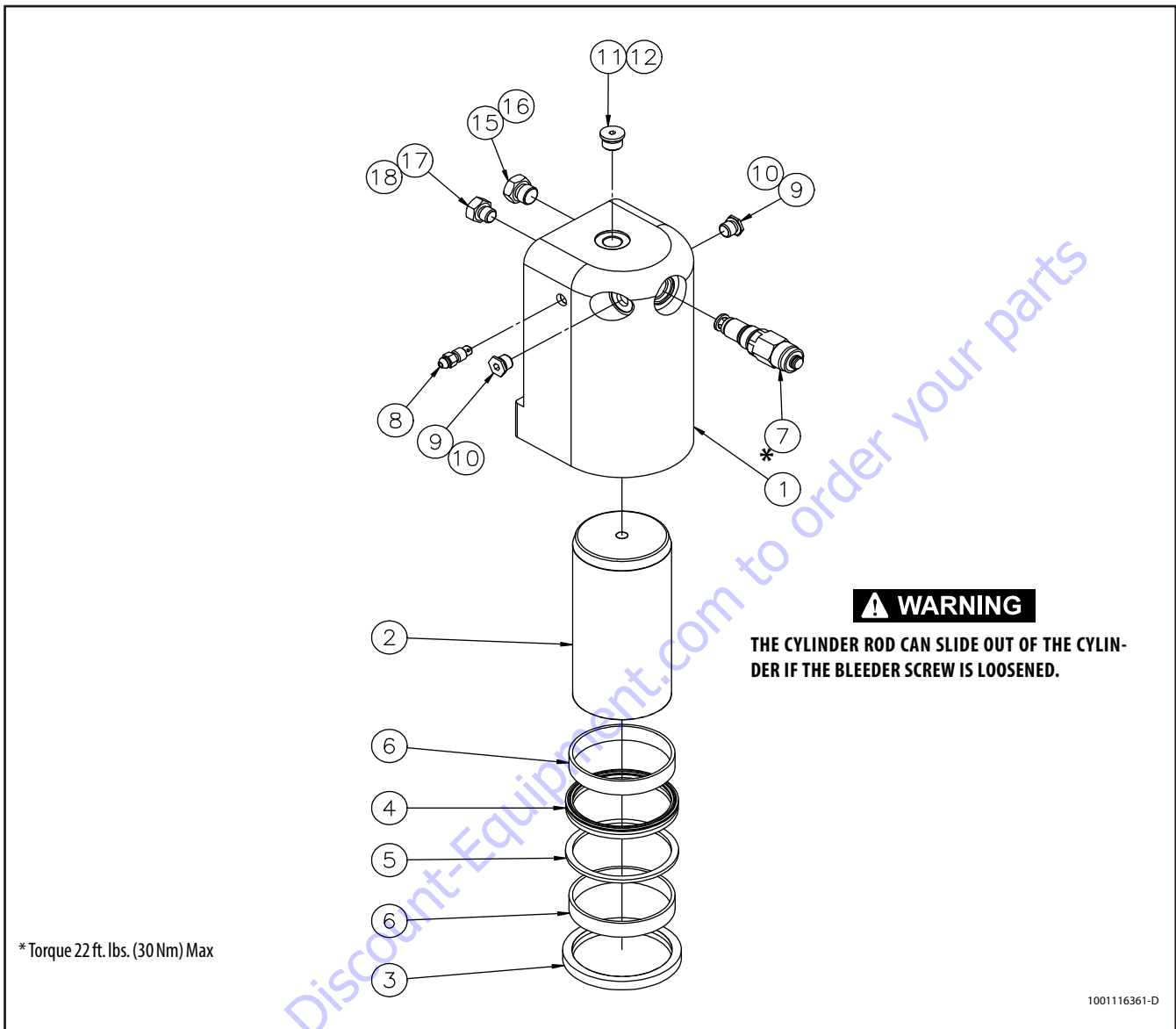

- |                |                         |              |            |
|----------------|-------------------------|--------------|------------|
| 1. Body        | 6. Wear Ring            | 11. Plug     | 16. O-ring |
| 2. Rod         | 7. Counterbalance Valve | 12. O-ring   | 17. Plug   |
| 3. Dust Wiper  | 8. Bleeder              | 13. Not Used | 18. O-ring |
| 4. Rod Seal    | 9. Plug                 | 14. Not Used |            |
| 5. Backup Ring | 10. O-ring              | 15. Plug     |            |

Figure 5-10. Axle Lockout Cylinder



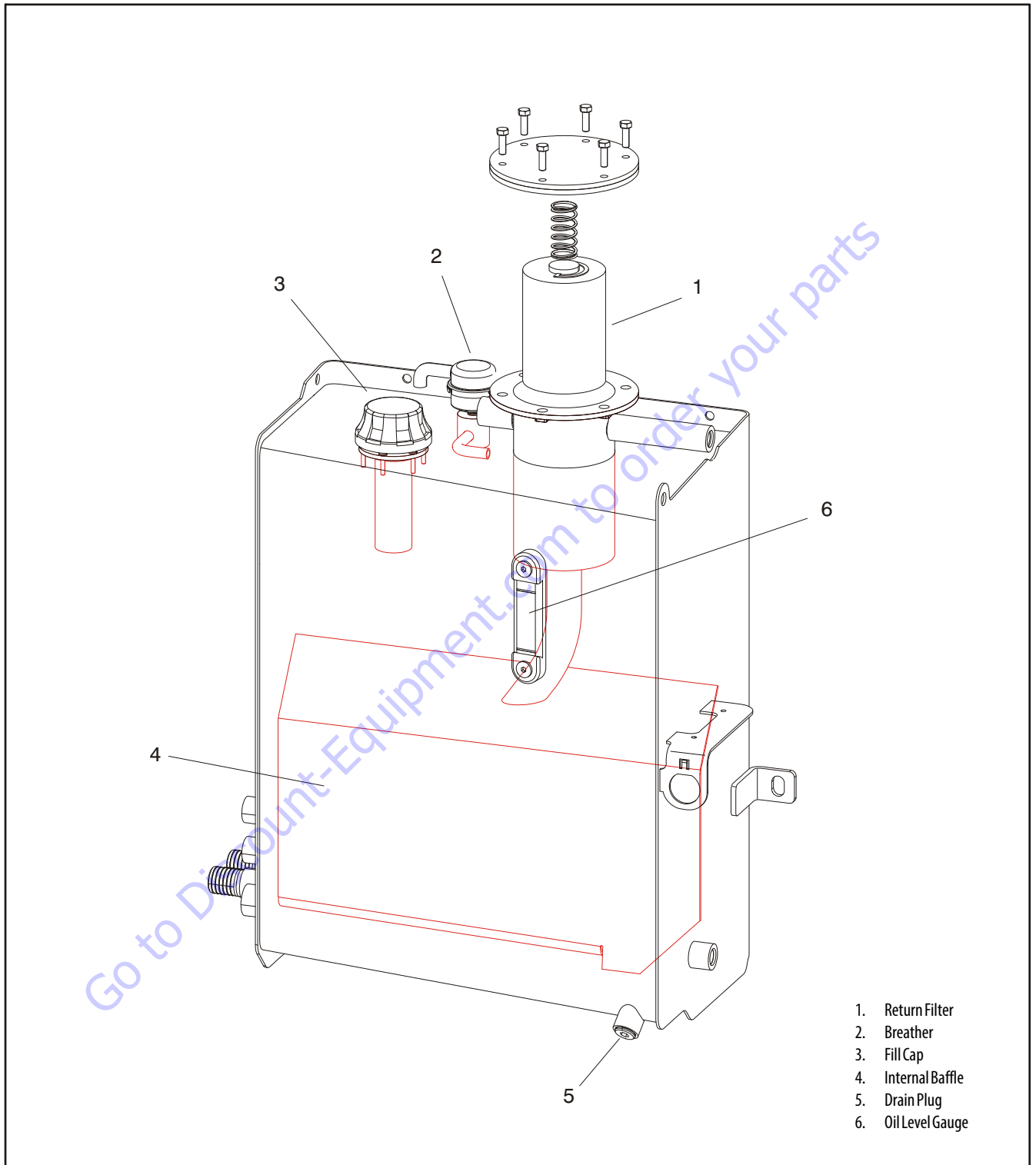
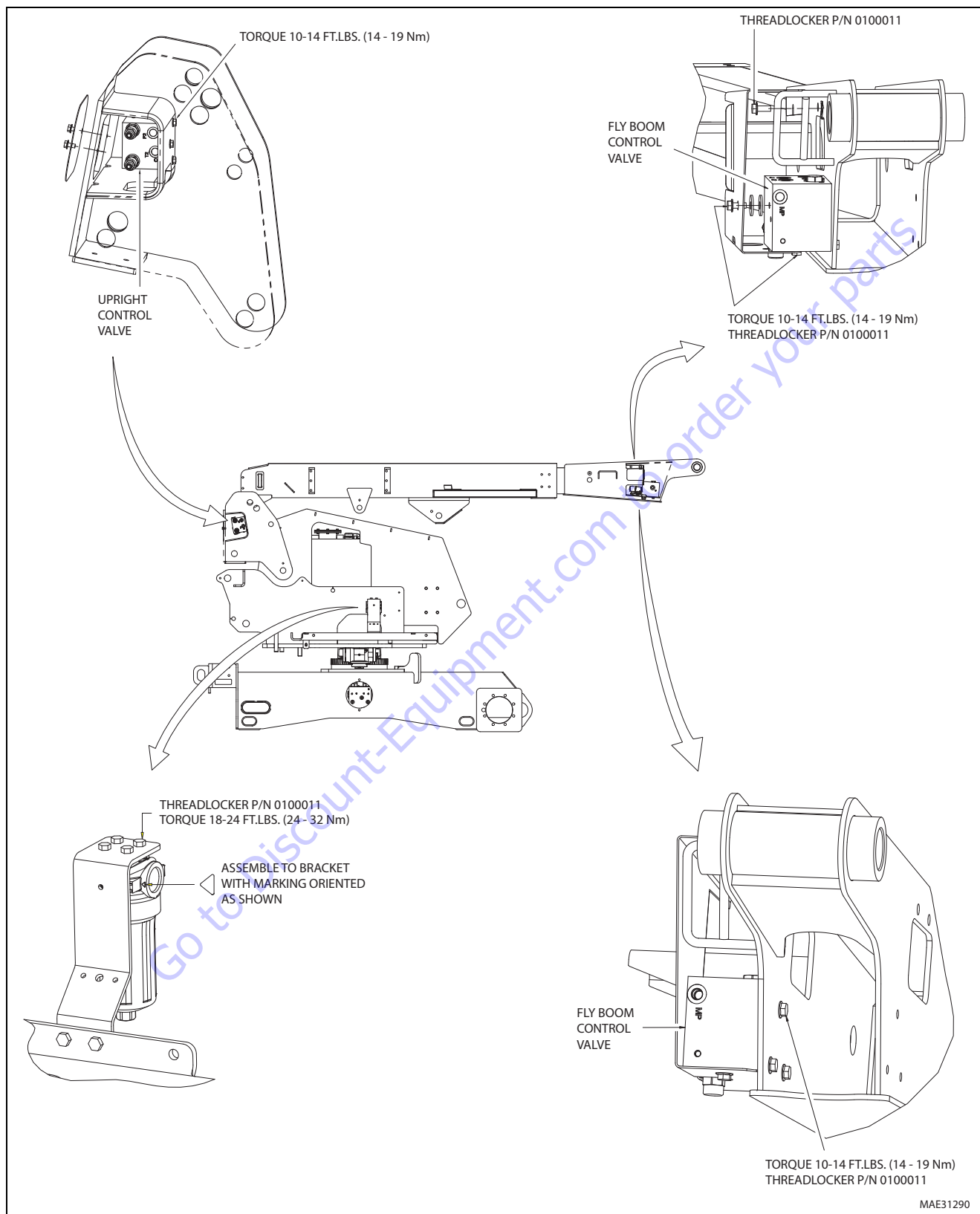

Figure 5-11. Hydraulic Tank

**SECTION 5 - BASIC HYDRAULIC INFORMATION & SCHEMATICS**



**Figure 5-11. Valve Installation - Sheet 1 of 2**

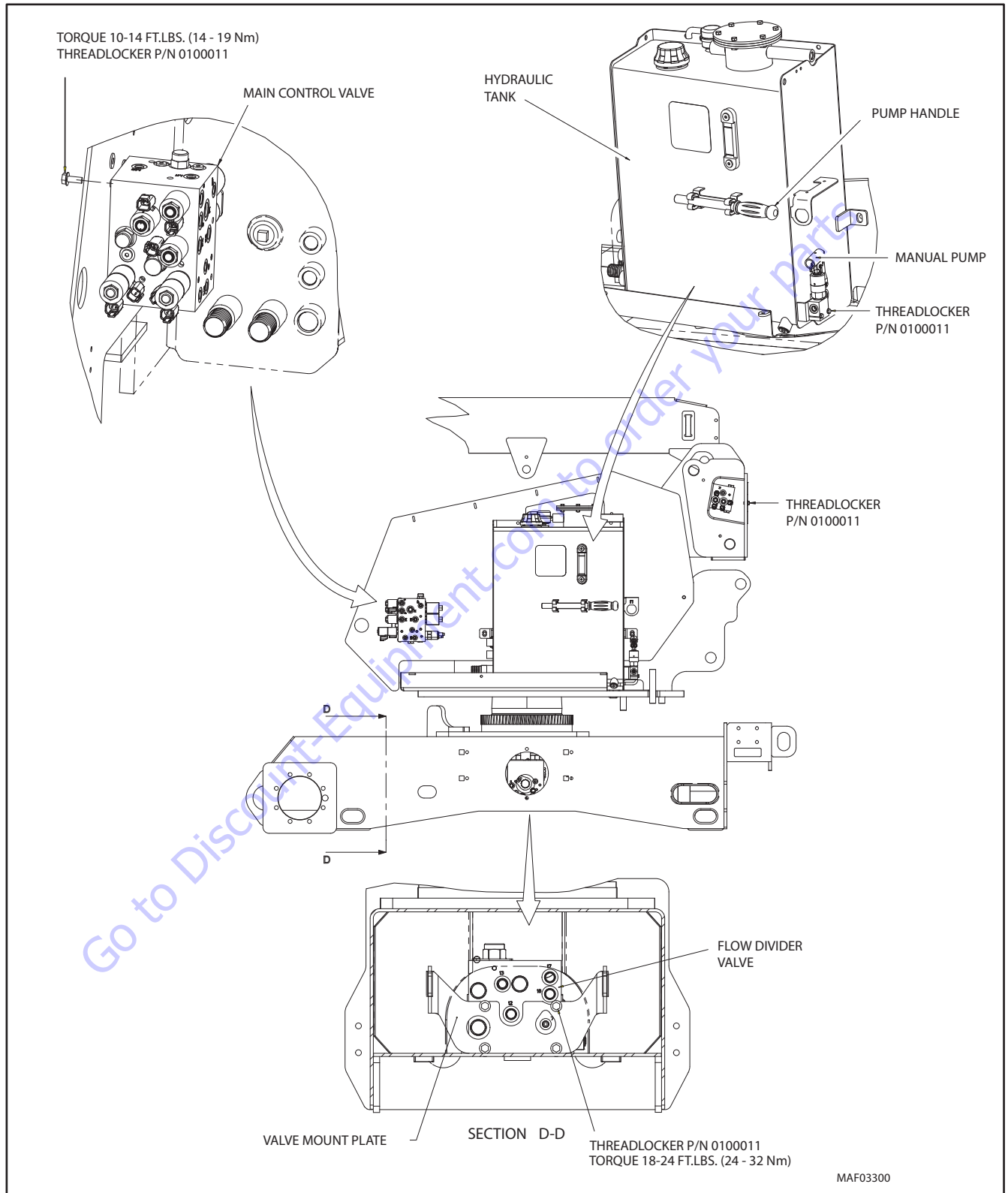

Figure 5-12. Valve Installation - Sheet 2 of 2

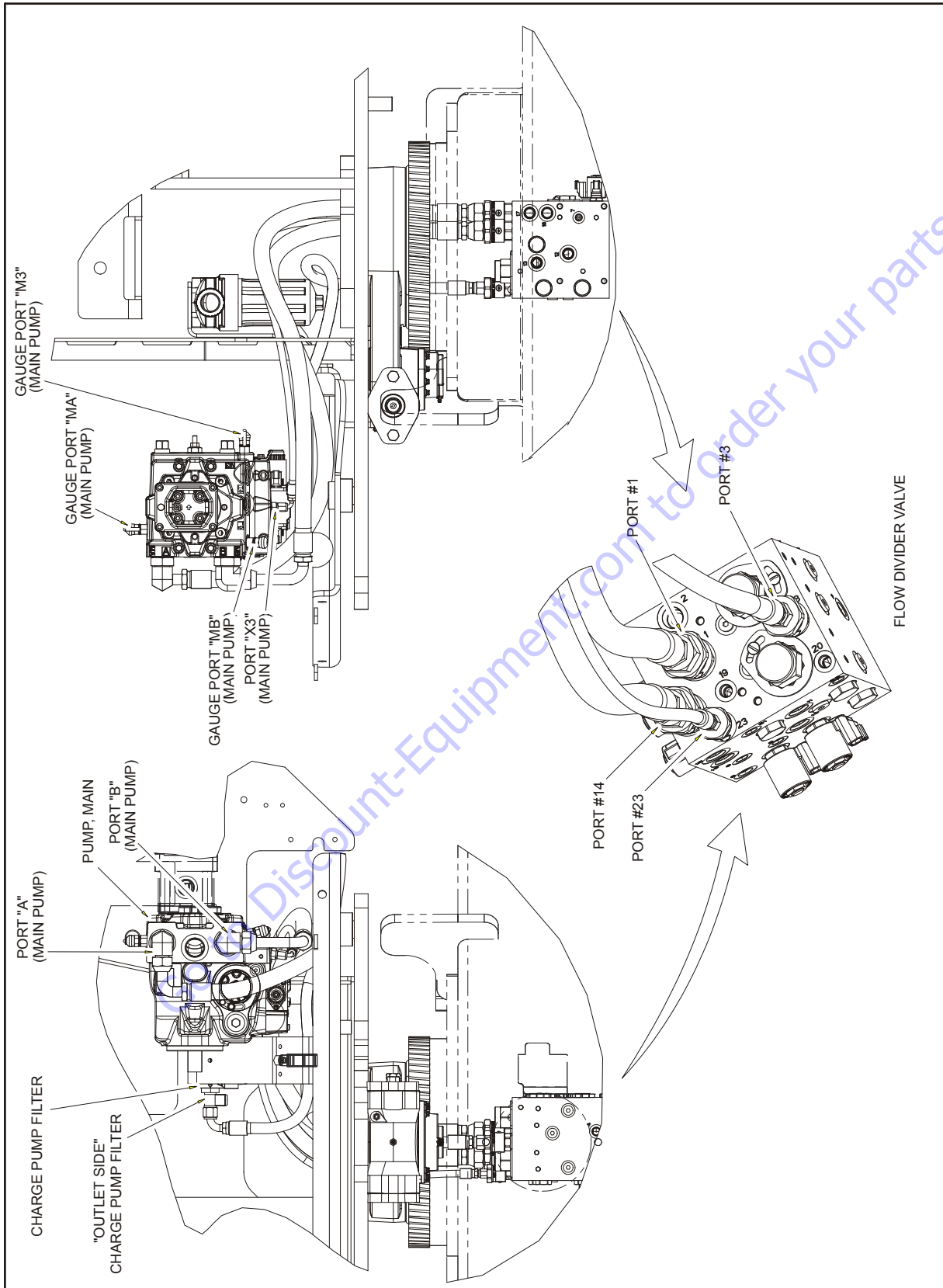

Figure 5-13. Main Pump\Charge Filter Hydraulic Lines

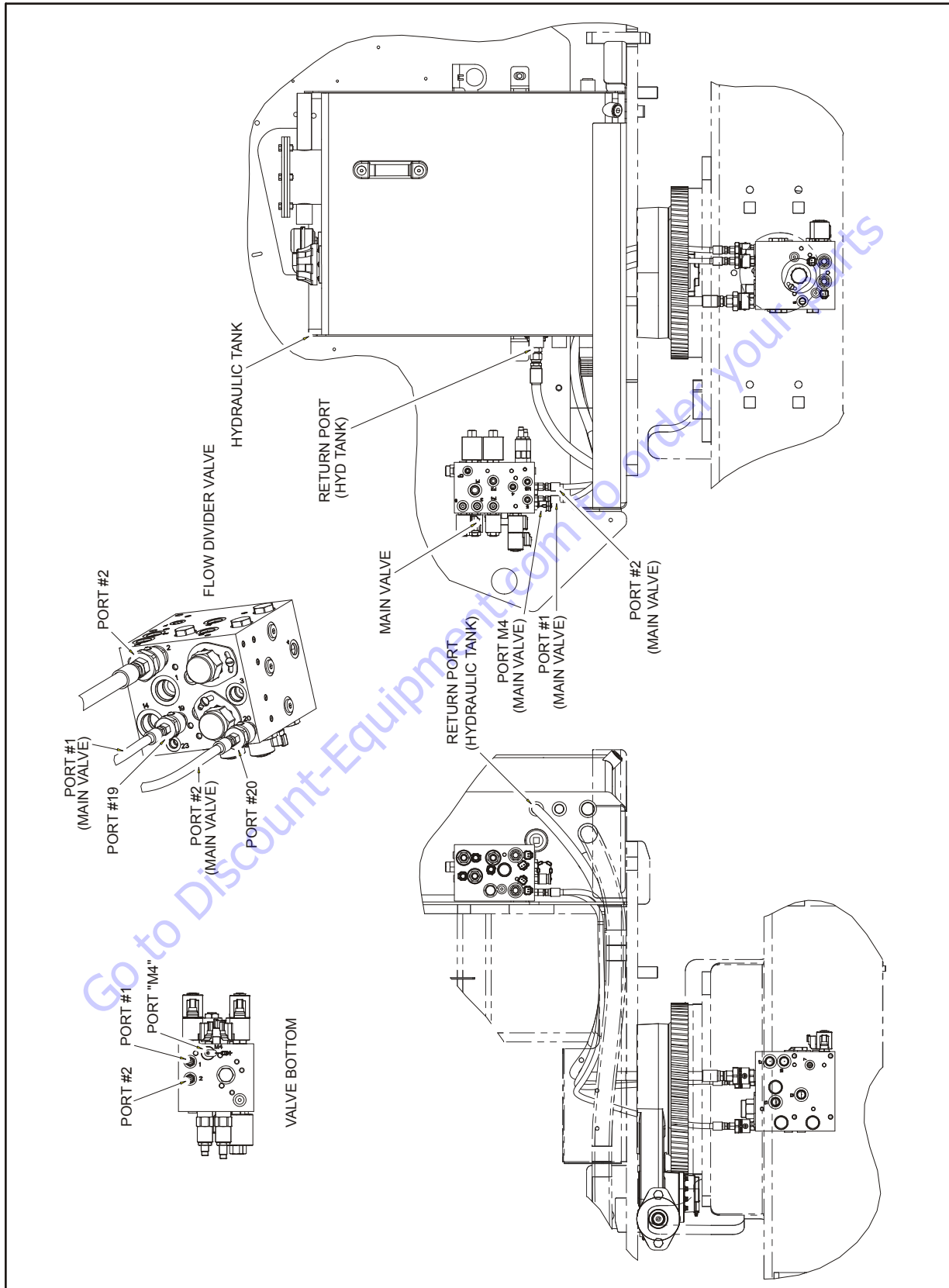

Figure 5-14. Main Pump/Main Valve Hydraulic Lines

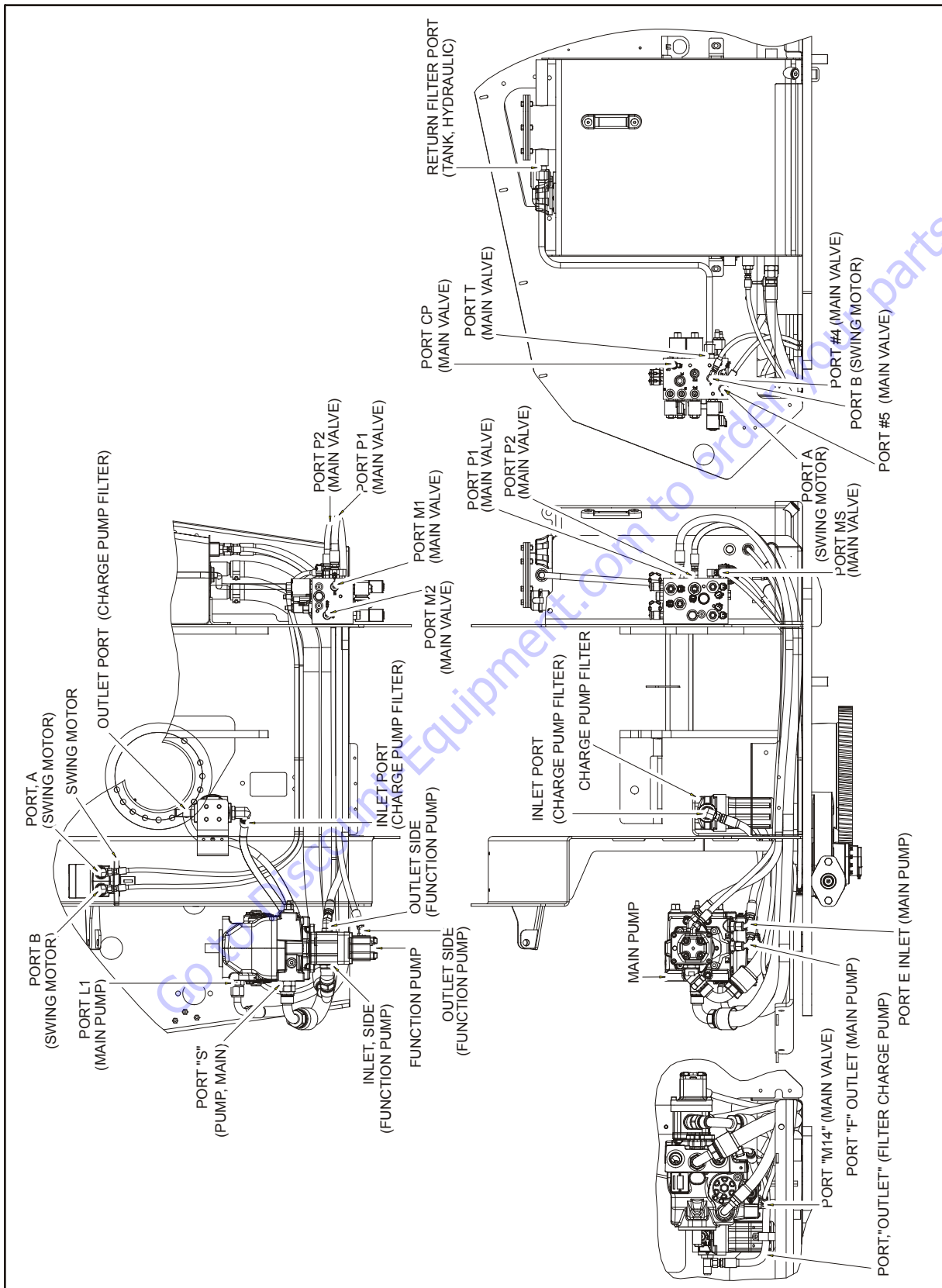

Figure 5-15. Drive Pump to Main Valve/Tank Hydraulic Lines

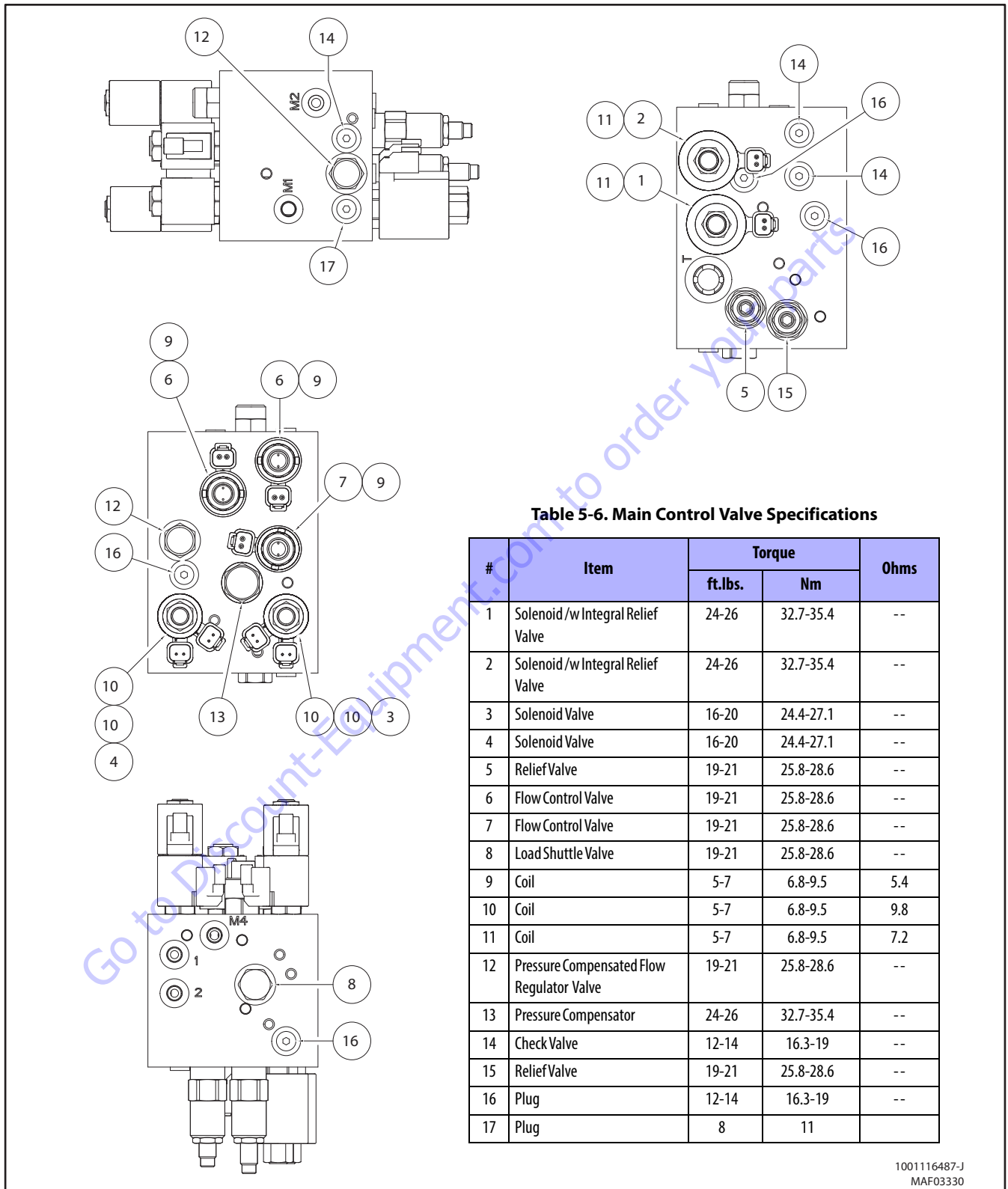

Figure 5-16. Main Control Valve Torque Specifications

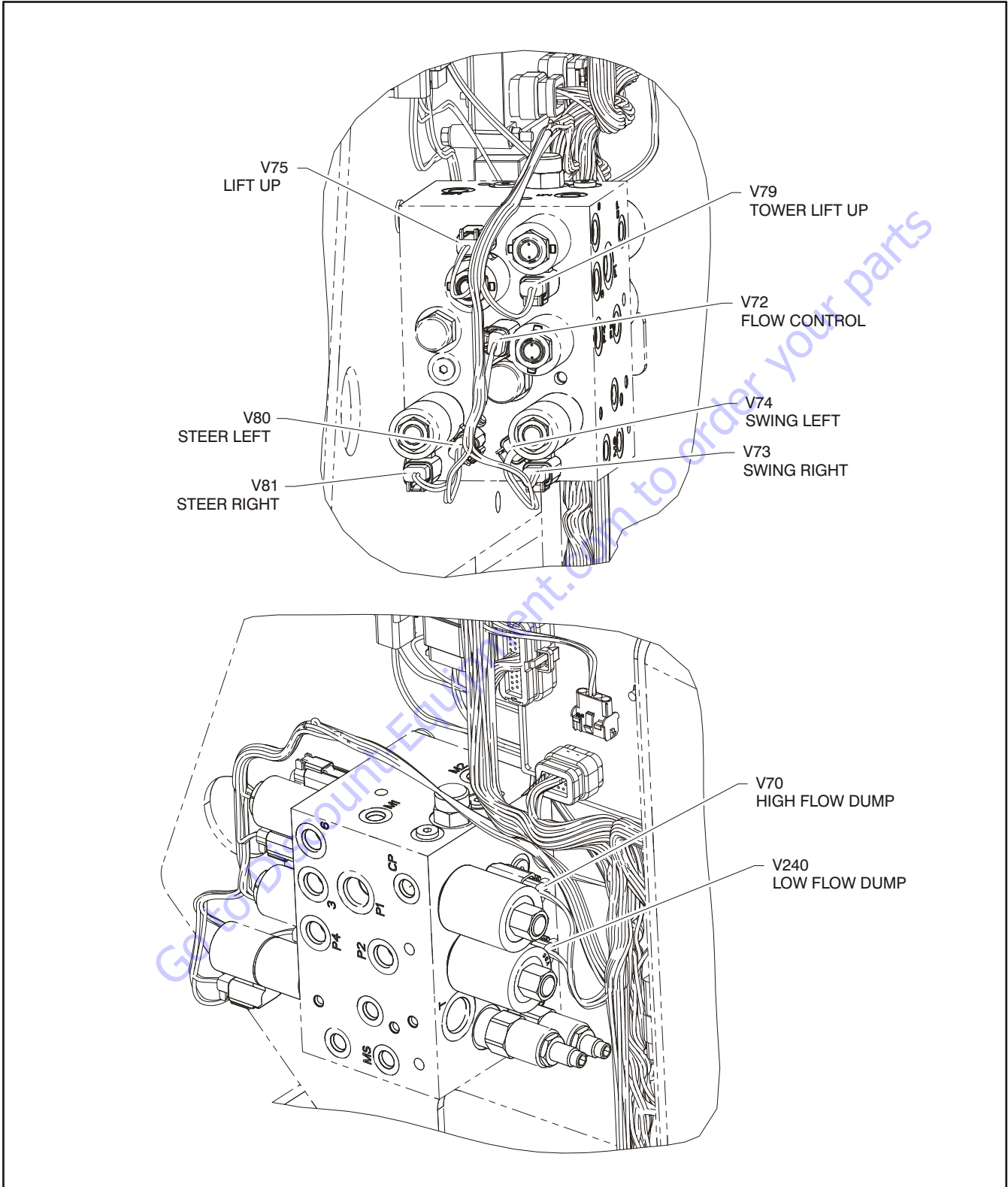

Figure 5-17. Main Control Valve Identification



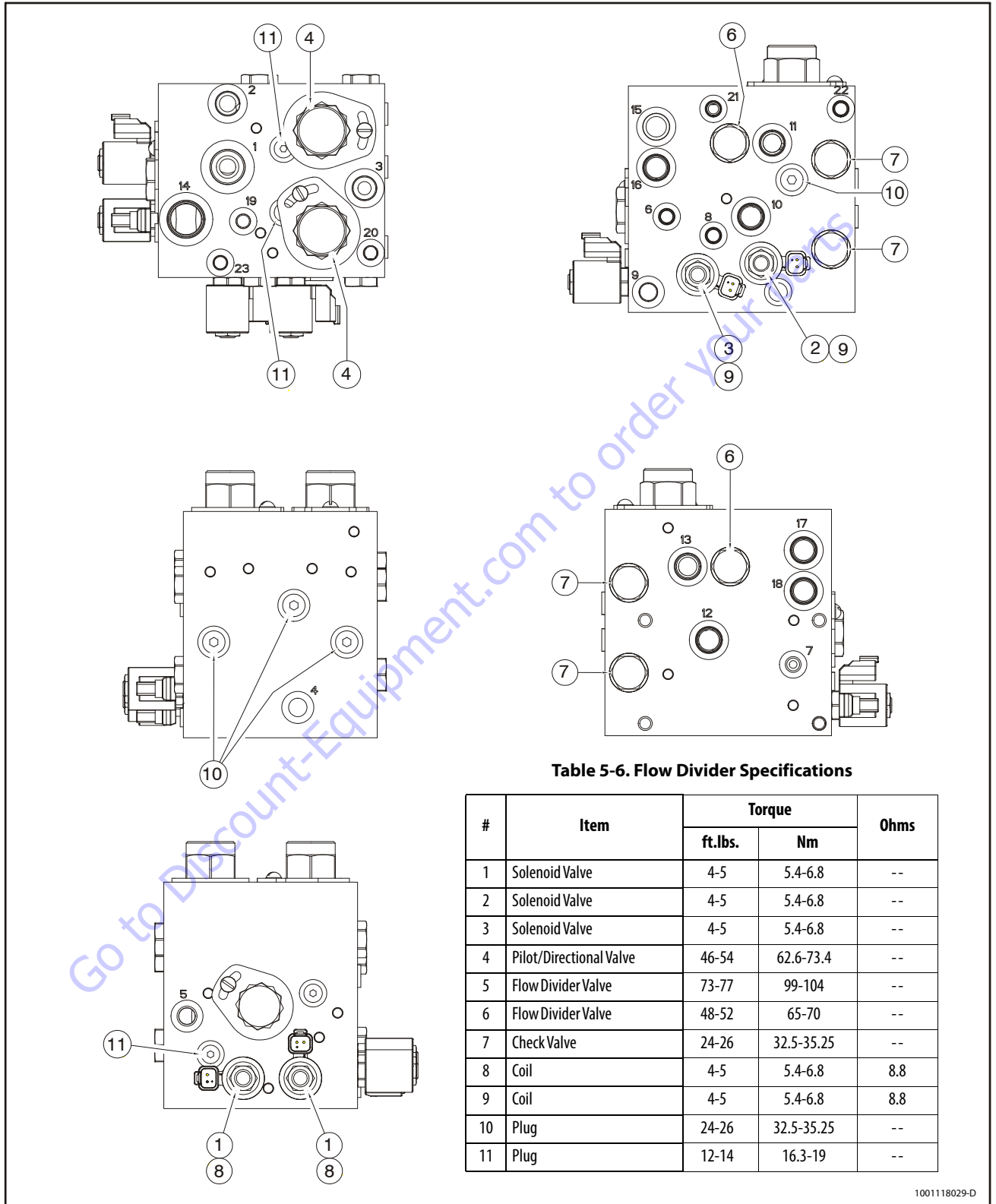

Figure 5-18. Flow Divider Valve Torque Specifications

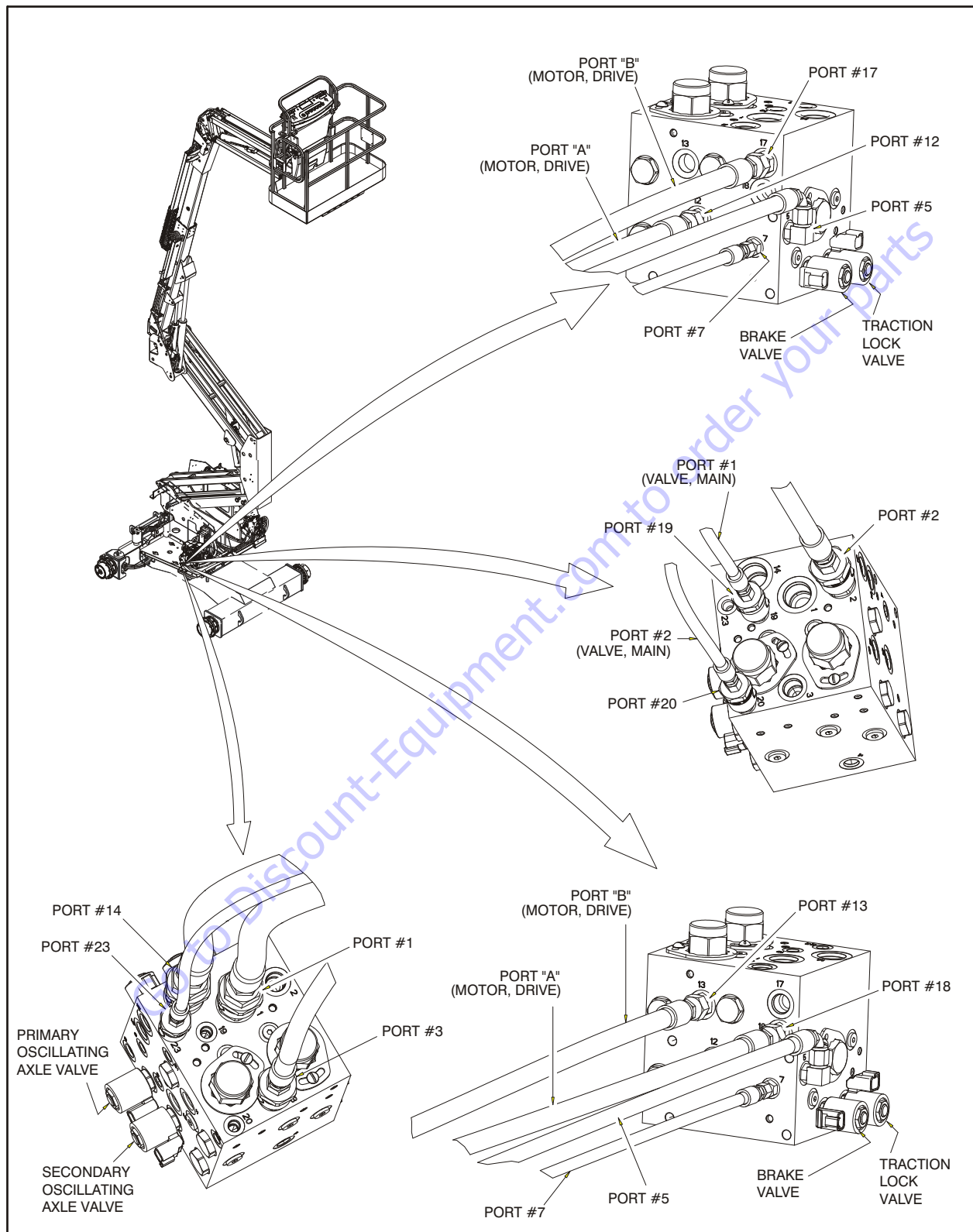

Figure 5-19. Flow Divider Valve Identification - Sheet 1 of 3

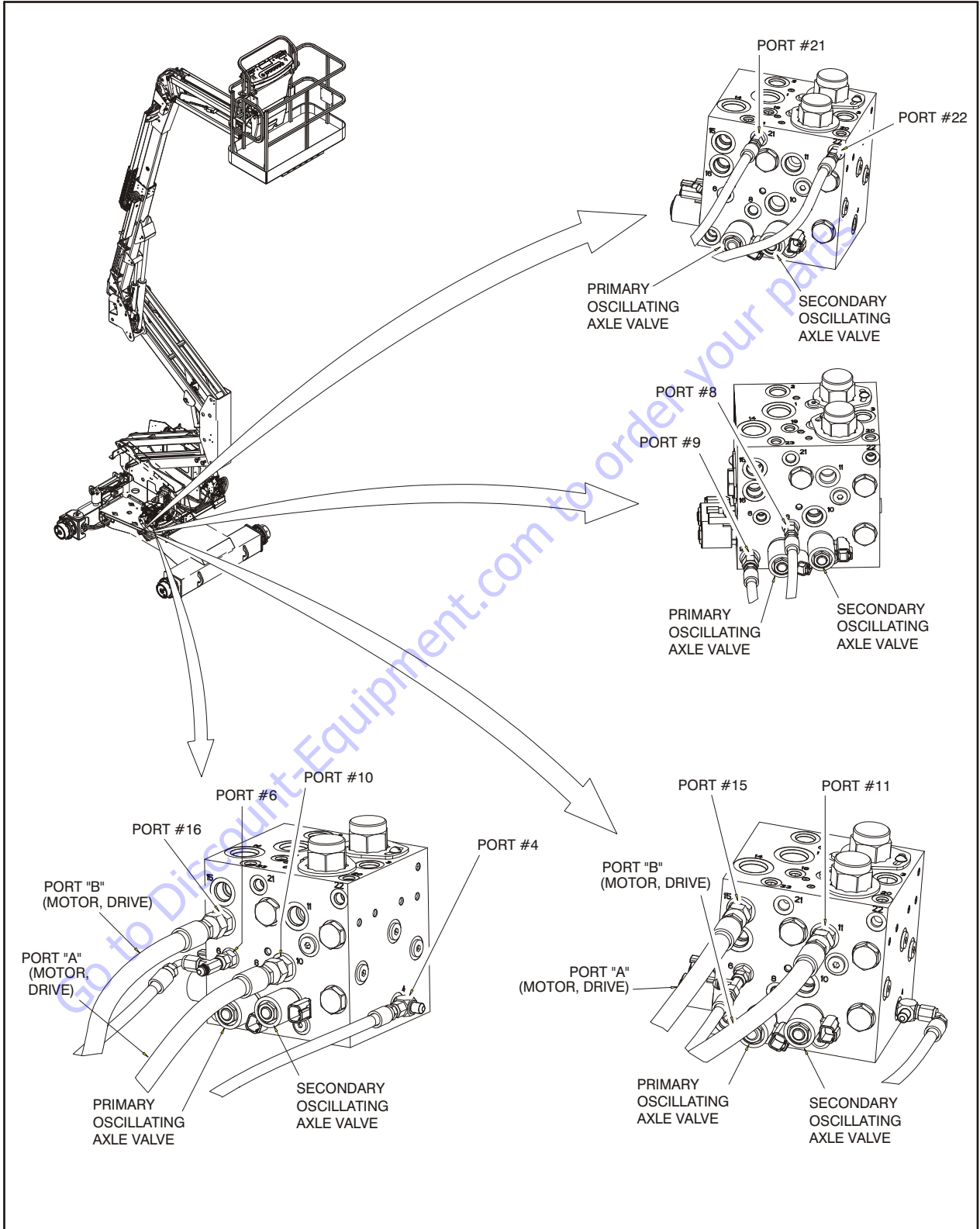

Figure 5-20. Flow Divider Valve Identification - Sheet 2 of 3

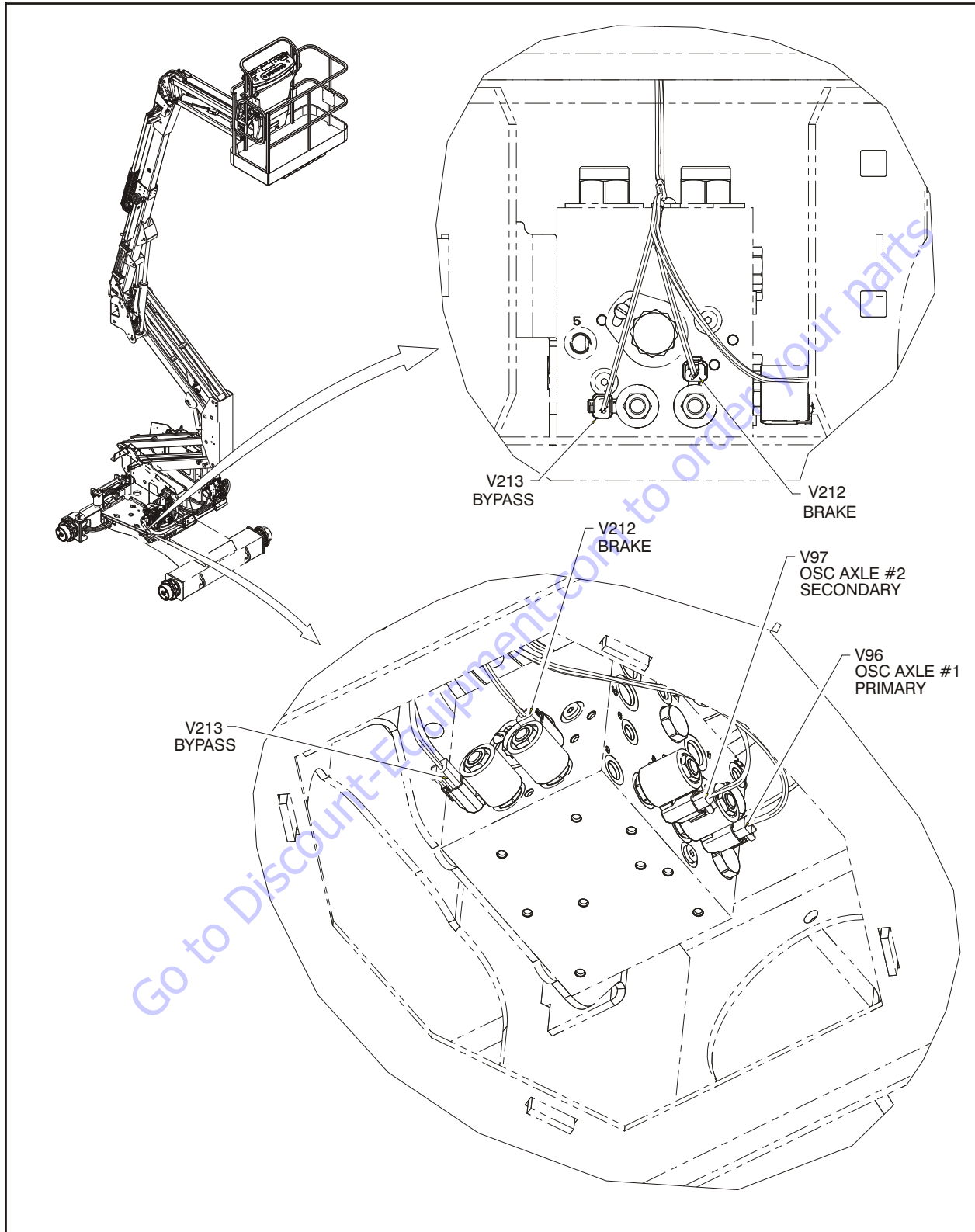

Figure 5-21. Flow Divider Valve Identification - Sheet 3 of 3

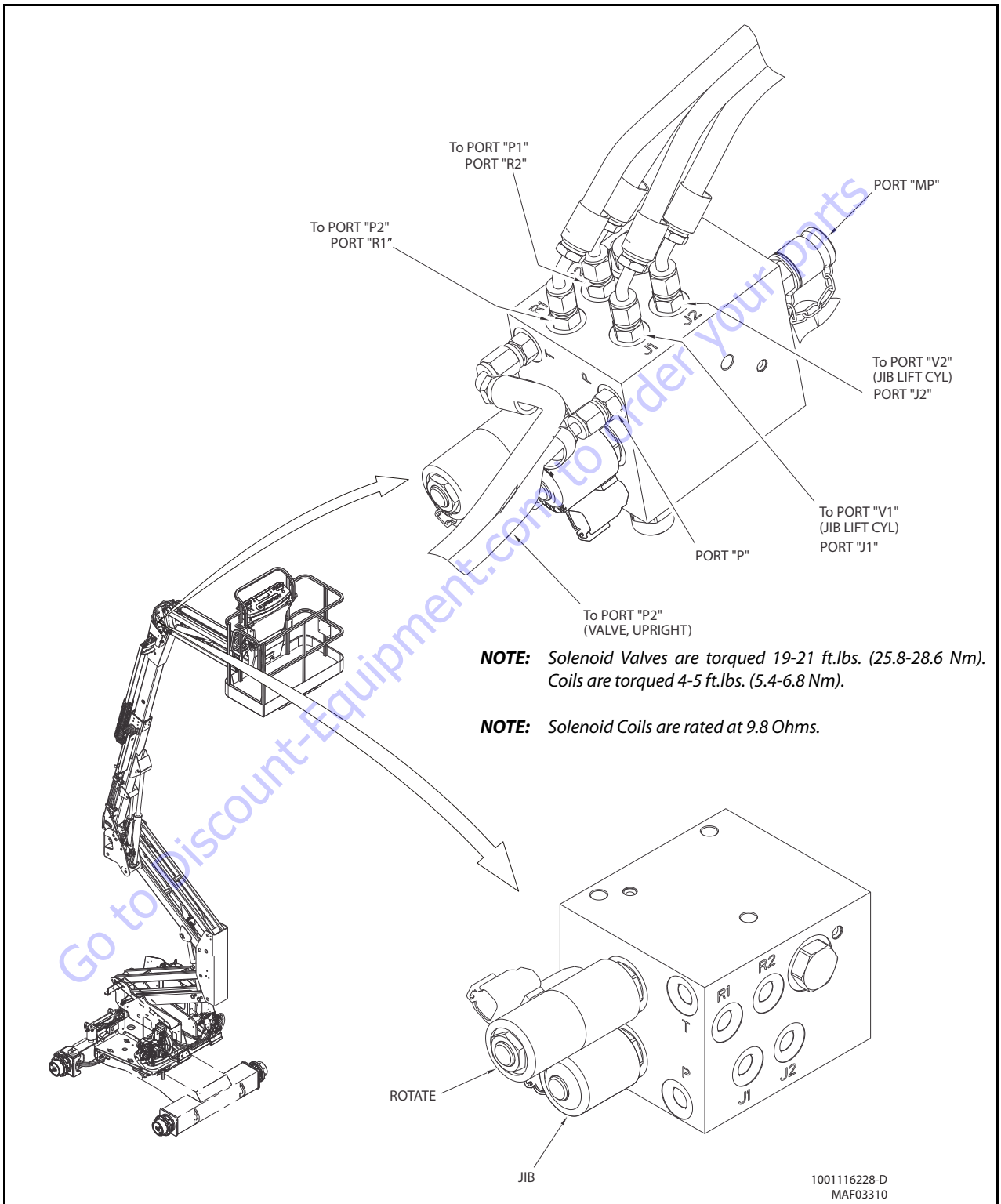
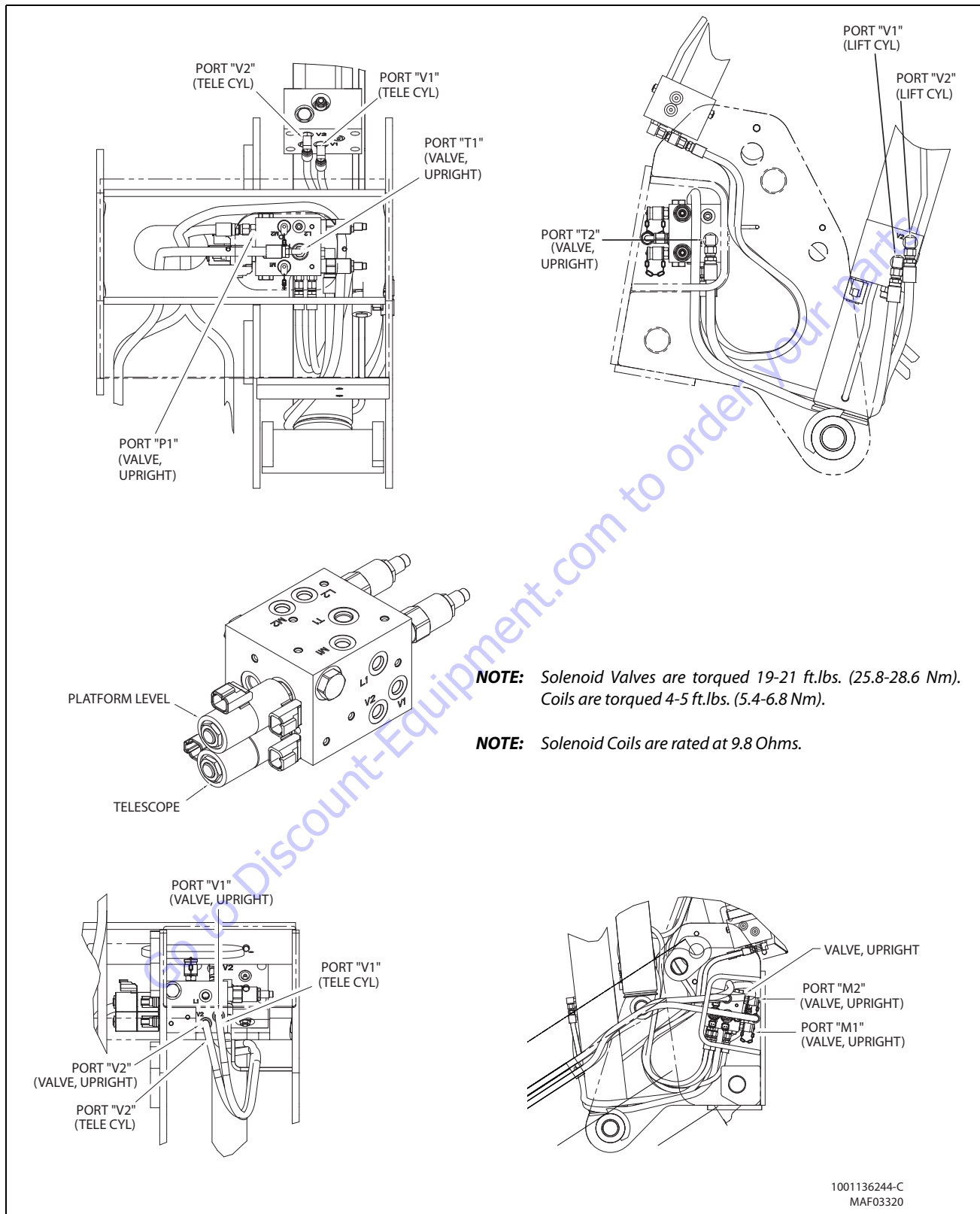

Figure 5-22. Fly Boom Control Valve Identification

**SECTION 5 - BASIC HYDRAULIC INFORMATION & SCHEMATICS**



**Figure 5-23. Upright Control Valve Identification**

### 5.3 DRIVE PUMP

#### Description

Sauer-Danfoss H1 tandem closed circuit piston pumps convert input torque to hydraulic power. The tandem design powers two independent drive trains for dual-path propel applications. The two-piece input shaft transmits rotational force to the cylinder block. A splined coupling connects the front and rear shafts. Bearings at the front, rear, and center of the pump support the shaft. Splines connect each shaft to a cylinder block. A lip-seal at the front end of the pump prevents leakage where the shaft exits the pump housing. The spinning cylinder block contains nine reciprocating pistons. Each piston has a brass slipper connected at one end by a ball joint. The block spring, ball guide, and slipper retainer hold the slippers to the swash plate. The reciprocating movement of the pistons occurs as the slippers slide against the inclined swashplates during rotation. Via the valve plates, one half of each cylinder block is connected to port A or C and the other half to port B or D. Front and rear sections have independent porting in the

center section. As each piston cycles in and out of its bore, fluid is drawn from one port and displaced to the other thereby imparting hydraulic power into the system. A small amount of fluid is allowed to flow from the cylinder block/valve plate and slipper/swashplate interfaces for lubrication and cooling. Case drain ports return this fluid to the reservoir. An external charge pump (not shown) provides clean, cool fluid to makeup this lubricating flow and to maintain minimum loop pressure.

The angle of each swashplate controls the volume and direction of fluid displaced into the system. The servo pistons control the angle of the swashplates. Each pump control, by varying the pressure at the servo pistons, controls each piston's position. An electric signal to the control coils transmits the command from the operator to the pump. Mechanical feedback of the swashplate position to the control through the feedback pins allows for very precise displacement control and increases overall system stability. Non-feedback control options do not use the mechanical feedback link.

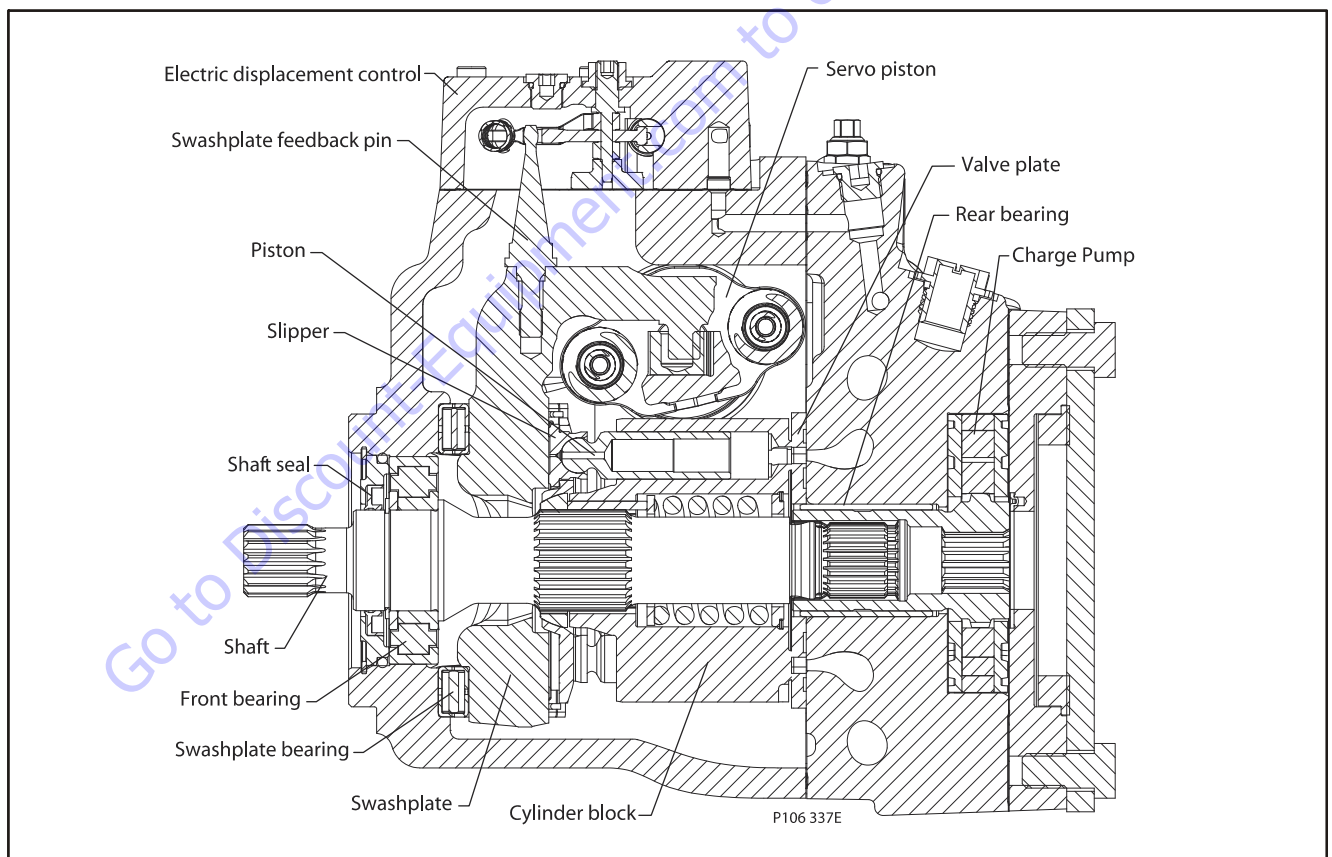

Figure 5-24. Drive Pump - Cross Sectional View

## The System Circuit

### THE BASIC CLOSED CIRCUIT

Hydraulic lines connect the main ports of the pump to the main ports of the motor. Fluid flows in either direction from the pump to the motor and back. Either of the hydraulic lines can be under high pressure. In pumping mode the position of the pump swashplate determines which line is high pressure as well as the direction of fluid flow.

### CASE DRAIN AND HEAT EXCHANGER

The pump and motor require case drain lines to remove hot fluid from the system. The pump and motor drain from the top-most port to ensure the cases remain full of fluid. The motor case drain can connect to the lower drain port on the pump housing or it can tee into the case drain line upstream of the heat exchanger. A heat exchanger with bypass valve cools the case drain fluid before it returns to the reservoir.

## High Pressure Relief Valve (HPRV) and Charge Check

All H1 pumps have a combination high pressure relief and charge check valve. The high-pressure relief function is a dissipative (heat generating) pressure control valve for the purpose of limiting excessive system pressures. The charge check function replenishes the low-pressure side of the working loop with charge oil. Each side of the transmission loop has a dedicated non-adjustable, factory-set HPRV valve. When system pressure exceeds the factory setting, oil is passed from the high pressure system loop into the charge gallery, and into the low pressure system loop via the charge check.

The pump may have different pressure settings at each system port. When an HPRV valve is used in conjunction with a pressure limiter, the HPRV valve is always factory set above the setting of the pressure limiter. The system pressure shown in the order code for pumps with only HPRV is the HPRV setting. The system pressure shown in the order code for pumps with pressure limiter and HPRV, is the pressure limiter setting.

**NOTE:** HPRVs are set at low flow condition. Any application or operating condition which leads to elevated HPRV flow will cause a pressure rise with flow above the valve setting.

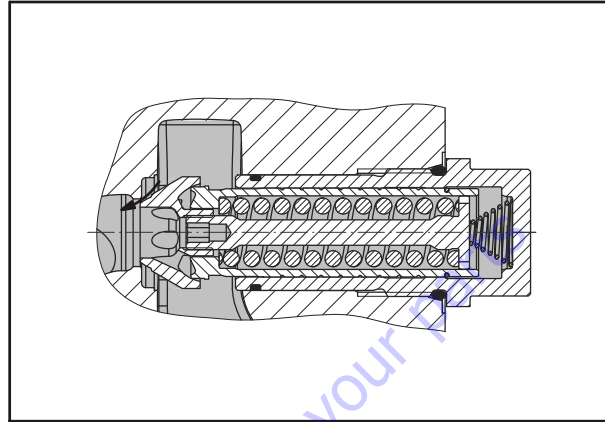

Figure 5-25. High Pressure Relief and Charge Check Valve with Bypass Valve in charging mode

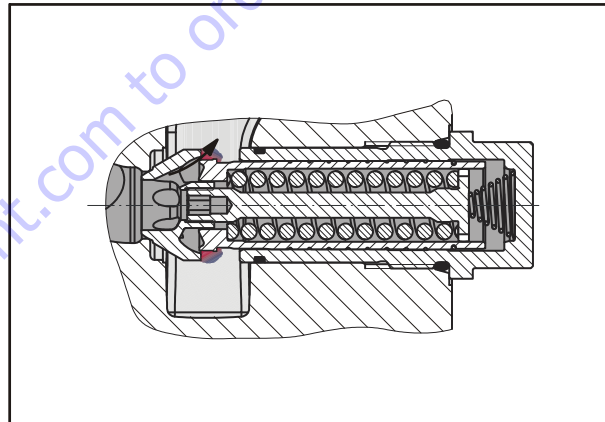

Figure 5-26. High Pressure Relief and Charge Check Valve with Bypass Valve in relief mode



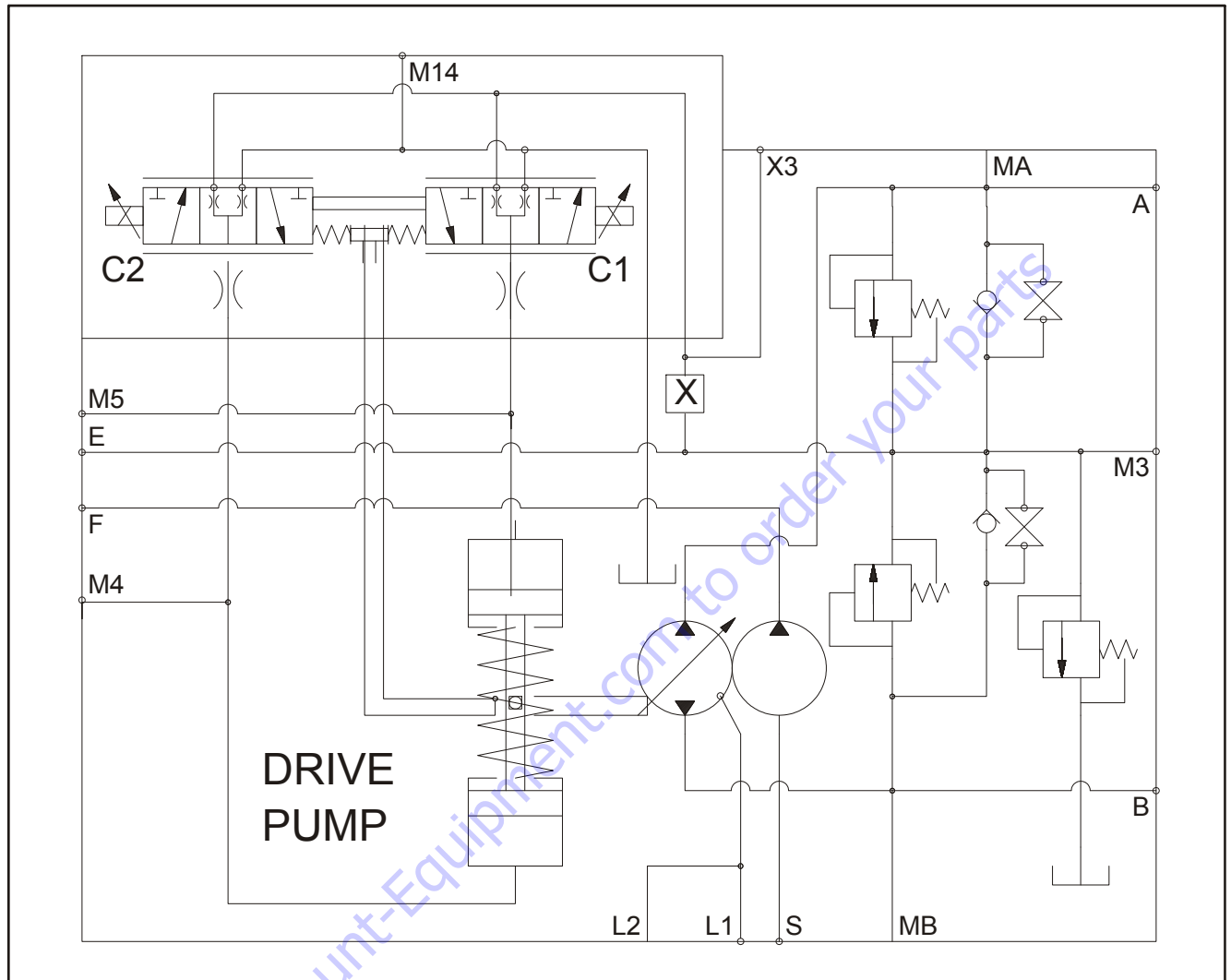

Figure 5-27. Drive Pump Hydraulic Schematic

### Charge Pressure Relief Valve

The charge pressure relief valve maintains charge pressure at a designated level above case pressure. The charge pressure relief valve is a direct acting poppet valve that opens and discharges fluid to the pump case when pressure exceeds a designated level. This level is nominally set with the pump running at  $1800 \text{ min}^{-1}$  (rpm). For external charge flow, the CPRV is set with a flow of  $30 \text{ l/min}$  [ $8 \text{ US gal/min}$ ]. In forward or reverse, charge pressure will be slightly lower than in neutral position. The model code of the pump specifies the charge relief setting.

Typically charge pressure increases from 1.2-1.5 bar per  $10 \text{ l/min}$  [ $17.4\text{-}21.8 \text{ psi}$  per  $2.64 \text{ US gal/min}$ ].

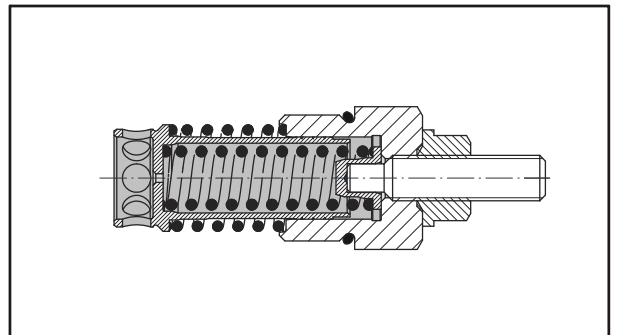

Figure 5-28. Charge pressure relief valve

### Electrical Displacement Control (EDC)

#### EDC PRINCIPLE

The Electrical Displacement Control (EDC) consists of proportional solenoids on each side of a three-position, four-way porting spool. The proportional solenoid applies a force to the spool, which ports hydraulic fluid to either side of the servo piston. Differential pressure across the servo piston rotates the swashplate, changing the pump's displacement from full displacement in one direction to full displacement in the opposite direction.

#### EDC OPERATION

H1 EDC's are current driven controls requiring a Pulse Width Modulated (PWM) signal. Pulse width modulation allows more precise control of current to the solenoids. The PWM signal causes the solenoid pin to push against the porting spool, which pressurizes one end of the servo piston, while draining the other. Pressure differential across the servo piston moves the swashplate. A swashplate feedback link, opposing control links, and a linear spring provide swashplate position force feedback to the solenoid. The control system reaches equilibrium when the position of the swashplate spring feedback force exactly balances the input command solenoid force from the operator. As hydraulic pressures in the operating loop change with load, the control assembly and servo/swashplate system work constantly to maintain the commanded position of the swashplate.

The EDC incorporates a positive neutral dead-band as a result of the control spool porting, spring preload from the servo piston assembly, and the linear control spring. Once the neutral threshold current is reached, the swashplate position becomes directly proportional to the control current. To minimize the effect of the control neutral deadband, we recommended the transmission controller or operator input device incorporate a jump up current.

**NOTE:** *The neutral position of the control spool does provide a positive preload pressure to each end of the servo piston assembly.*

When the control input signal is either lost or removed, or if there is a loss of charge pressure, the spring-loaded servo piston automatically returns the pump to neutral position.

The EDC is a displacement (flow) control. Pump swashplate position is proportional to the input command and therefore vehicle or load speed (excluding influence of efficiency), is

dependent only on the prime mover speed or motor displacement.

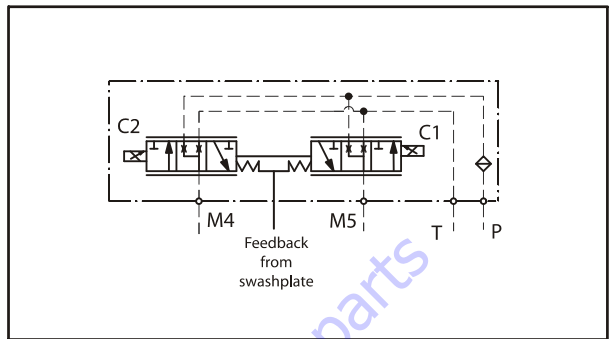

Figure 5-29. EDC-Schematic Diagram

	WARNING may result in injury		Lubricate with hydraulic fluid
	CAUTION may result in damage to product or property		Inspect for wear or damage
	Non-reusable part, use a new part		Note correct orientation
	Option – either part may exist		Torque specification
	Measurement required		Cover splines with installation sleeve
	External hex head		Pressure measurement/gauge location or specification
	Internal hex head		

**NOTE:** These symbols are used throughout the Drive Pump illustrations.

Figure 5-30. Symbol Chart

## Disassembly

### SHAFT SEAL REMOVAL

1. Orient pump with the shaft pointing up.
2. Remove the spiral ring (J300) from the front housing to release the shaft seal carrier (J275).

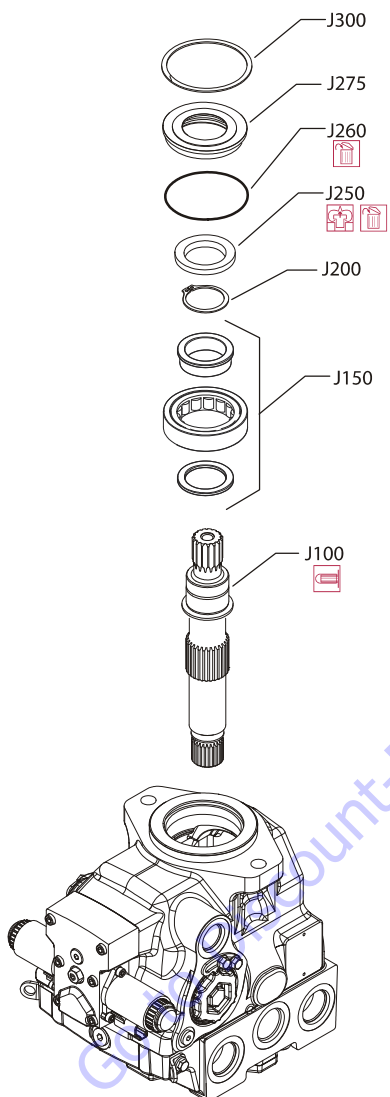

3. Pry on the lip of the seal carrier to remove it from the pump.
4. Remove and discard the O-ring (J260) and seal (J250) from the seal carrier.

### INPUT SHAFT

1. Pull the shaft with bearing out of the pump. If necessary, tap lightly on the shaft to dislodge it from the internal pump components.

### **CAUTION**

DO NOT DAMAGE THE HOUSING BORE, SHAFT OR BEARING WHEN REMOVING THE SHAFT AND SHAFT SEAL.

2. Remove the snap ring (J200) using snap ring pliers.
3. Use an adequate press to remove the bearing from the shaft.

### EDC CONTROL REMOVAL

1. Remove control screws (D250) using a 5 mm internal hex wrench. Remove the control from the pump.

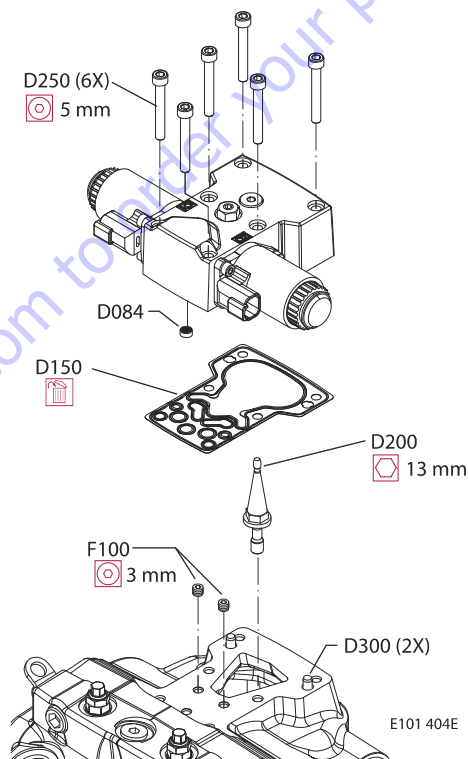

2. Remove and discard the gasket (D150).
3. Using a 13 mm deep well socket wrench, remove feedback pin (D200) from top of swash plate.
4. If necessary, remove the screen (D084).

### **CAUTION**

SCREEN (D084) MAY BE LOOSE AND FALL OUT OF CONTROL. TAKE CAUTION NOT TO LOSE IT.

5. If necessary, remove orifices (F100) using a 3 mm internal hex wrench.

### **NOTICE**

DOWEL PINS (D300) ARE A PRESS FIT AND WILL REMAIN IN HOUSING.

**EDC CONTROL DISASSEMBLY**

**NOTICE**

IT IS NOT NECESSARY TO REMOVE SOLENOIDS (D025) UNLESS YOU ARE REPLACING THEM.

1. Use a 4 mm internal hex wrench to remove cap screws (D050).

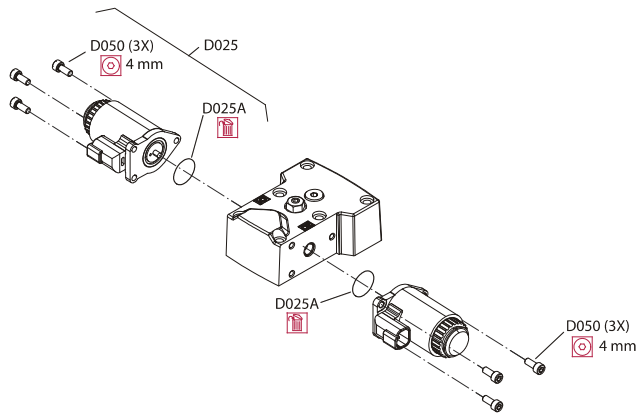

**NOTICE**

IF YOU SUSPECT A COIL MALFUNCTION, REMOVE THE COIL. REMOVE THE PLASTIC NUT WITH A 26 MM 12 POINT SOCKET. INSTALL A NEW COIL. TORQUE NUT TO 5 NM [3.7 FT.LBS.].

2. Remove solenoids (D025). Remove and discard O-rings (D025A).

**NOTICE**

DO NOT DISASSEMBLE INTERNAL PARTS OF CONTROL. INTERNAL PARTS ARE NOT AVAILABLE SEPARATELY. CONTROL IS SOLD AS A COMPLETE UNIT ONLY.

**AUXILIARY PAD OR END COVER REMOVAL**

**NOTICE**

REMOVE AUXILIARY PUMP, IF PRESENT.

1. Position pump so end cover (K100) or auxiliary pad is on top.

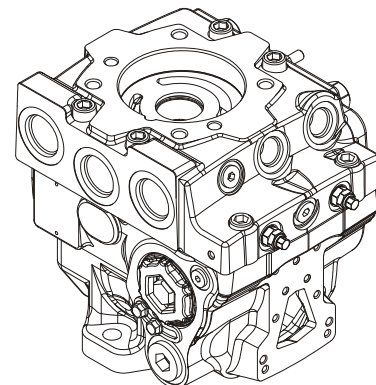
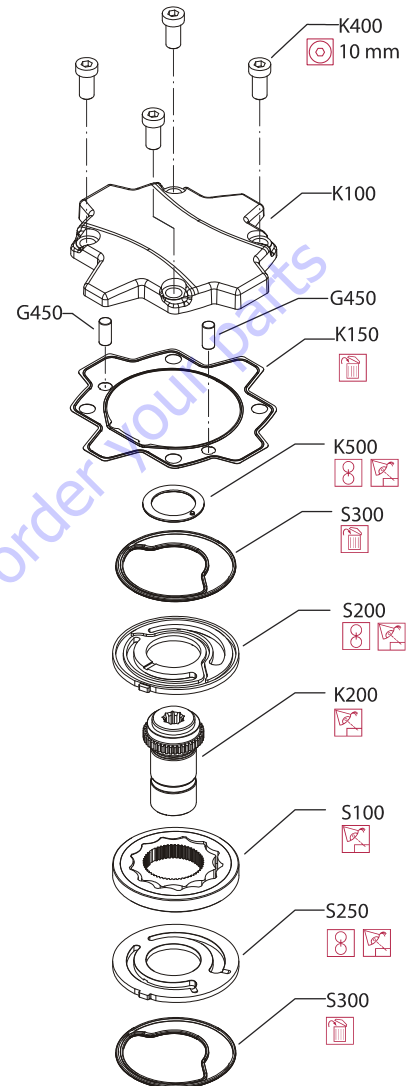

2. Remove end cover/auxiliary pad screws (K400) using an 8 mm internal hex wrench.

**NOTICE**

**ALIGNMENT PINS (G450) ARE IN END COVER. THEY MAY DISLodge DURING DISASSEMBLY.**

3. Remove and discard gasket (K150).
4. Remove thrust washer (K500). Note thrust washer orientation.
5. Remove pressure balance plate (S200) and seal (S300). Note plate orientation. Discard seal (S300).
6. Remove coupling (K200).

**CHARGE PUMP REMOVAL**

1. Remove charge pump outer ring (S150), and gear-set (S100).
2. Remove valve plate (S250) with seal (S300). Discard seal (S300).

**NOTE:** If charge pump requires replacement, replace as a kit. Kit includes (S300), (S250), (S100), and (S200).

**PRESSURE LIMITER REMOVAL**

1. Using a 14 mm wrench, remove pressure limiter cartridges (L300) and (L400).

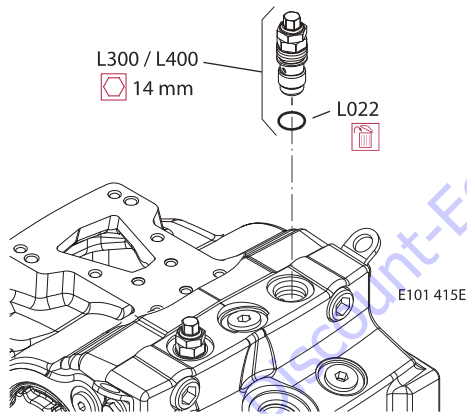

**NOTE:** Pressure limiter (L300 / L400) is available as complete unit only. Seal (L022) is available separately.

2. Remove and discard O-ring (L022).

**NOTE:** Right and left pressure settings are different. Tag each valve for later re-assembly

**CHARGE PRESSURE RELIEF VALVE REMOVAL**

Using a 22 mm wrench, remove the charge pressure relief valve (V10). Discard O-ring (V024).

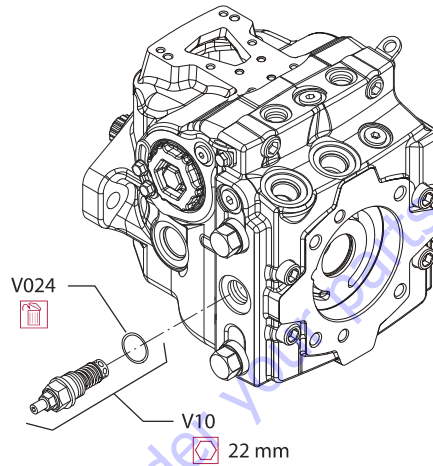

**NOTE:** Charge pressure relief valve (V10) is available as complete unit only. Seal (V024) is available separately.

**HIGH PRESSURE RELIEF VALVE REMOVAL**

Using a 22 mm wrench, remove the HPRV valves (L100 / L200). Discard O-rings (L060) and seals (L068).

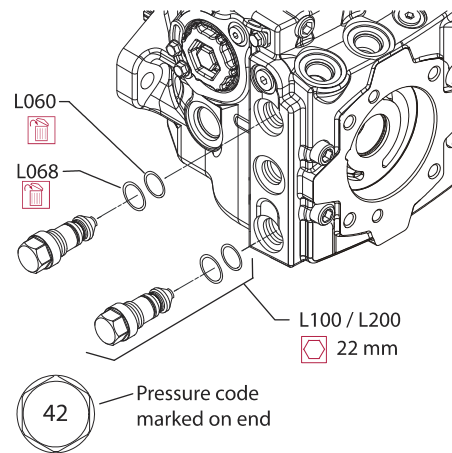

**NOTE:** HPRV valves may not have the same pressure setting. Tag each valve for reassembly.

**ENDCAP REMOVAL**

1. Remove two endcap screws (G400) using a 10 mm internal hex wrench.

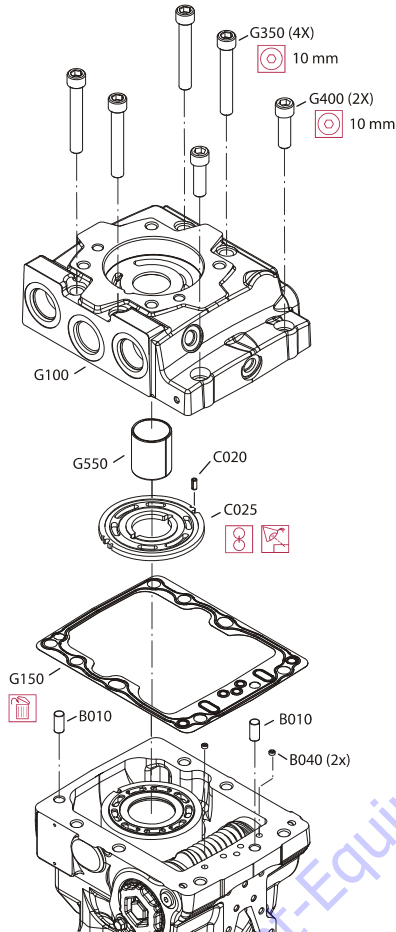

2. Remove four endcap screws (G350) using a 10 mm internal hex wrench.
3. Carefully remove the endcap (G100) and valveplate (C025). Valveplate may be stuck to endcap. Alignment pin (C020) may remain in endcap.

**NOTICE**

**NOTE VALVE PLATE ORIENTATION FOR PROPER REASSEMBLY.**

4. Place the endcap and valve plate in a clean area, protecting them from contamination.
5. Remove and discard gasket (G150).
6. If necessary, remove bushing (G550) using a suitable puller.
7. Remove locating pins (B010).

**NOTE:** If necessary, use a hook to remove screens (B040) and discard.

**CYLINDER BLOCK KIT REMOVAL**

1. Remove cylinder block assembly (C010).

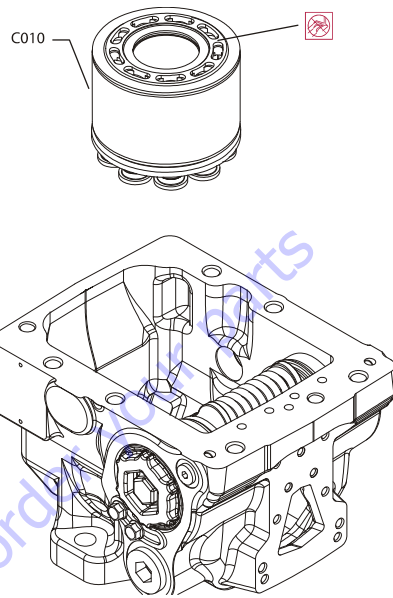

2. Set cylinder block and components on a clean dry surface.

**CAUTION**

**DO NOT SCRATCH THE RUNNING SURFACES OF THE CYLINDER BLOCK OR SLIPPERS. SCRATCHES IN THESE SURFACES CAN LEAD TO POOR PERFORMANCE OR PUMP FAILURE.**

**SERVO SLEEVE REMOVAL**

1. If equipped, remove and discard locking nut (E550) and remove displacement limiter screw (E450).

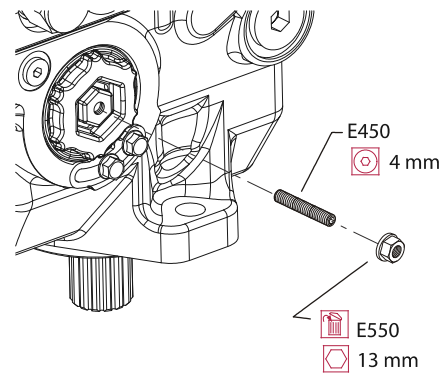

2. Remove the locking screws (E350) with a 10 mm hex wrench. Remove the locking plates (E300).

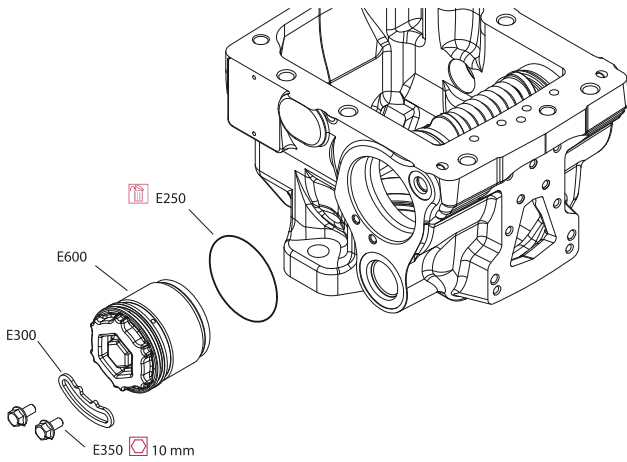

3. Using a 3/4 in. deep socket, unthread the servo sleeves (E600) from each side of the pump. Servo piston will be loose after servo cylinders are removed. Discard O-rings (E250).

**CAUTION**

**DO NOT ALLOW LOOSE SERVO PISTON TO DAMAGE INTERNAL MACHINED SURFACES OF PUMP.**

**SERVO PISTON REMOVAL**

Tilt swashplate up to disengage servo arm from piston. Remove the servo piston assembly (E100).

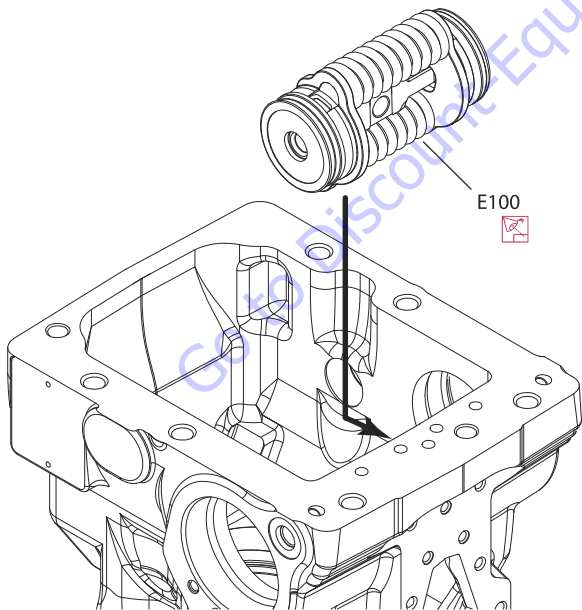

**SWASHPLATE AND SWASHPLATE BEARING REMOVAL**

1. Lift the swashplate (D070) out by grasping the swashplate pin. Swashplate bearings (D075) will remain on the swash plate.

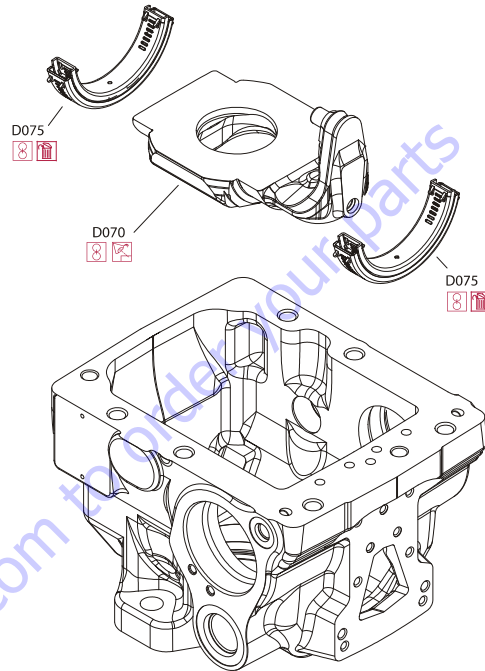

2. Remove bearings (D075) by sliding them from the swashplate and discard them.

**NOTICE**

**DO NOT REUSE SWASHPLATE BEARINGS.**

**SERVO PISTON DISASSEMBLY**

1. Remove and discard seals (E025).

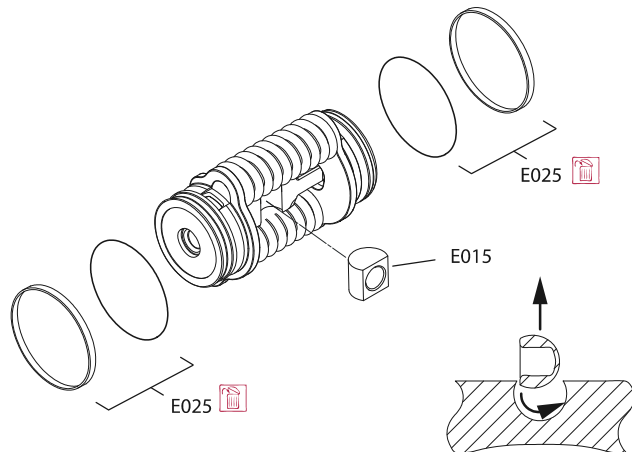

2. Remove slider block (E015).



**NOTE:** Servo (E100) is available as an assembly only. Seals (E025) and slider block (E015) are available as repair items.

**CYLINDER KIT**

1. Pull to remove the slipper retainer (C20) with the pistons (C10) from the cylinder kit.

**NOTE:** The pistons are not selectively fitted, however units with high hourly usage may develop wear patterns. Number the pistons and bores for reassembly if they are to be reused.

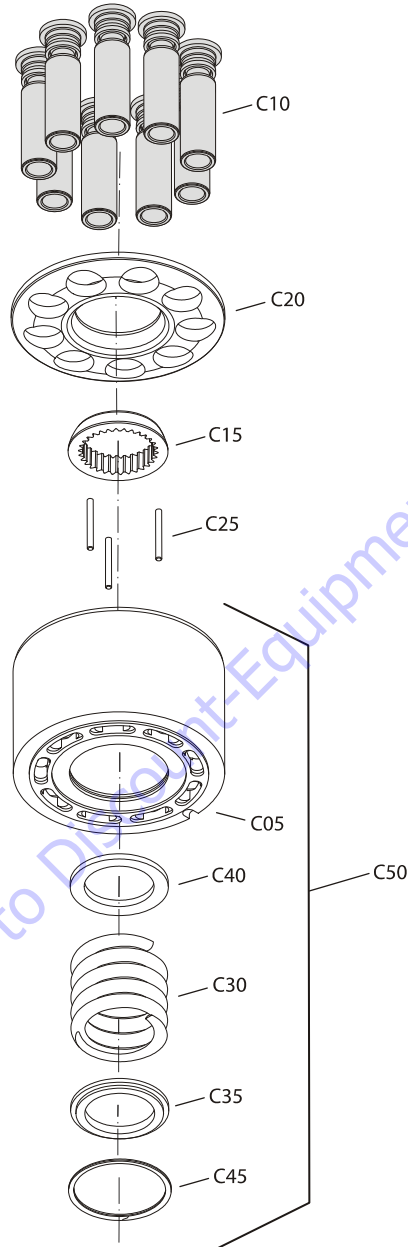

2. Remove the ball guide (C15).
3. Remove the three pins (C25).

**BLOCK SPRING REMOVAL**

**NOTE:** Most repairs do not require block spring removal. Perform the following only if you suspect problems with the block spring.

1. Turn the block over. Using a press, apply pressure on the block spring washer (C35) to compress the block spring (C30). Compress the spring enough to safely remove the spiral retaining ring (C45). While maintaining pressure, unwind the spiral retaining ring. Carefully release the pressure and remove the outer block spring washer, block spring, and inner block spring washer (C40) from the cylinder block.

**⚠ WARNING**

**RISK OF PERSONAL INJURY: COMPRESSING THE BLOCK SPRING REQUIRES ABOUT 350 TO 400 N [80 TO 90 LBF]. USE A PRESS SUFFICIENT TO MAINTAIN THIS FORCE WITH REASONABLE EFFORT.**

**ENSURE THE SPRING IS SECURE BEFORE ATTEMPTING TO REMOVE THE SPIRAL RETAINING RING. RELEASE THE PRESSURE SLOWLY AFTER THE RETAINING RING IS REMOVED.**

**Inspection**

**OVERVIEW**

After disassembly, wash all parts (including the end-cap and housing) thoroughly with clean solvent and allow to air dry. Blow out oil passages in the housing and endcap with compressed air. Conduct inspection in a clean area and keep all parts free from contamination. Clean and dry parts again after any rework or resurfacing.

**PISTONS AND SLIPPERS**

Inspect the pistons for damage and discoloration. Discolored pistons may indicate excessive heat; do not reuse.

Inspect the running surface of the slippers. Replace any piston assemblies with scored or excessively rounded slipper edges. Replace any piston assemblies with excessively worn slippers. Check the slipper axial end-play. Replace any piston assemblies with excessive end-play.

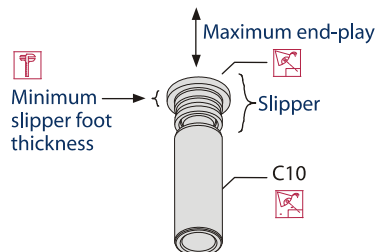

**BALL GUIDE, SLIPPER RETAINER, AND HOLD-DOWN PINS**

Ensure ball guide is free of nicks and scratches, and not scored. Examine for discoloration that may indicate excessive heat or lack of lubrication. The slipper retainer should be flat, and slippers should fit in the retainer with minimal side play. Place the hold-down pins on a flat surface and roll them to make sure they are straight. Discard and replace any damaged parts.

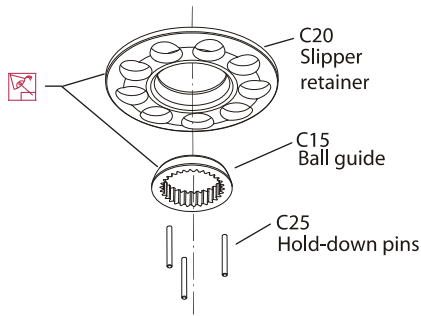

**BLOCK SPRING, AND WASHERS**

If cylinder kit was fully disassembled, visual inspection of the cylinder block, spring, and washers should indicate minimal wear. Replace if cracks or other damage are present.

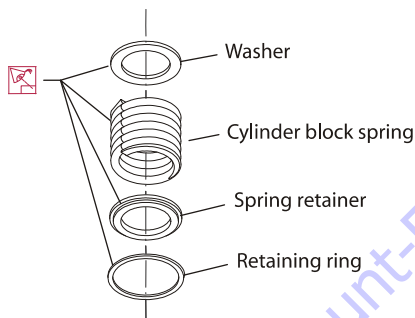

**CYLINDER BLOCK**

Examine the running face of the cylinder block. The surface should be smooth and free of nicks and burrs. Ensure that no scratches or grooves exist; these may drastically reduce output flow.

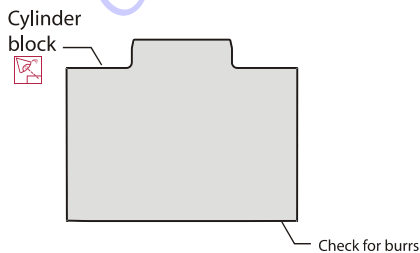

**SHAFT**

Check to see that the shaft and its splines are straight and free of damage or heavy wear. Inspect the shaft surface where it meets the shaft seal. Replace the shaft if a groove exists at the sealing land surface where it meets the shaft seal. Clean the sealing area with a nonabrasive material if necessary. Lubricate the shaft with a light coat of hydraulic fluid before reassembly.

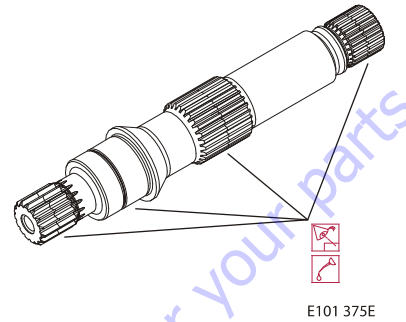

**SHAFT BEARING**

Clean bearing with a solvent and lubricate with hydraulic fluid. Inspect for wear, or pitting. Rotate the bearing in your hand. Replace if it does not rotate smoothly.

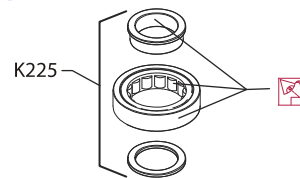

**SWASHPLATE**

Carefully inspect each machined surface of the swashplate for wear. Ensure all swashplate surfaces are smooth. Inspect the swashplate's slipper running surface for flatness and brass transfer. Excessive brass transfer from slippers may indicate you should replace the slippers. Check the journals for scratches. Replace swashplate if necessary.

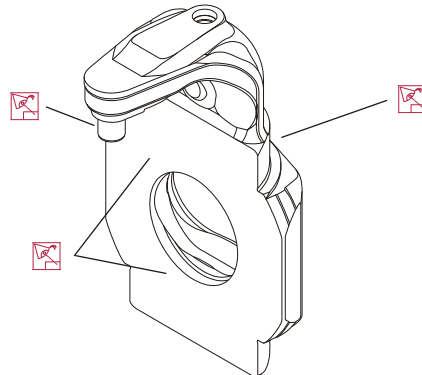

**VALVE PLATE**

Inspect the valve plate for scratches and grooves. Check the plate for pitting along the running face. If pitting from cavitation exists, replace the valve plate. Check for excess wear on the brass running face. If you observe any discoloration or burn marks, replace the valve plate.

Run a fingernail or pencil tip across the diameter of the sealing land surface (see illustration). You should feel no deep or outstanding grooves. These may decrease pump flow. Lap or replace if grooves or nicks are present. Inspect the mating surfaces of the endcap and valve plate for any possible contamination; even a few thousandths of an inch may affect pump operation.

Ensure plate appears flat and smooth on both the running face and the bottom surface. Perform a magnetic particle inspection to detect cracks. Replace if any cracks exist.

Counterclockwise valveplate

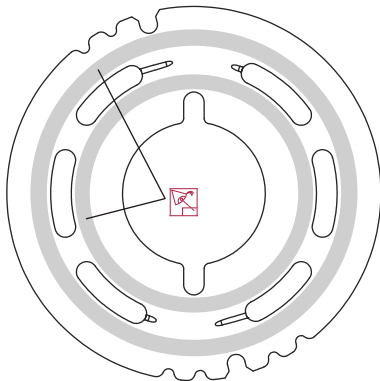

Clockwise valveplate

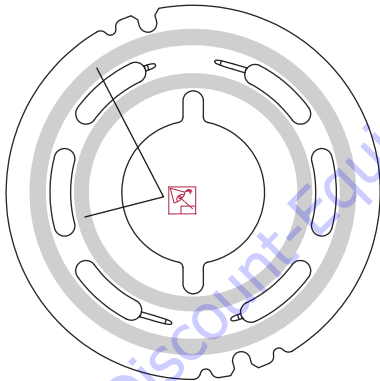

**ENDCAP**

Inspect the endcap. Inspect all machined surfaces for scratches or pits. Carefully check the bearing surface for wear. Inspect valve seats carefully for wear or cracks. Replace if damaged.

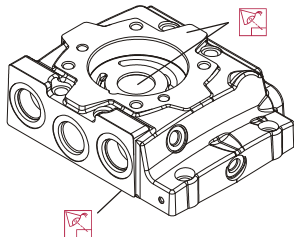

**HOUSING**

Inspect the housing to ensure that it is clean and free of foreign material. Inspect the washplate bearing surfaces, and endcap and control mating surfaces.

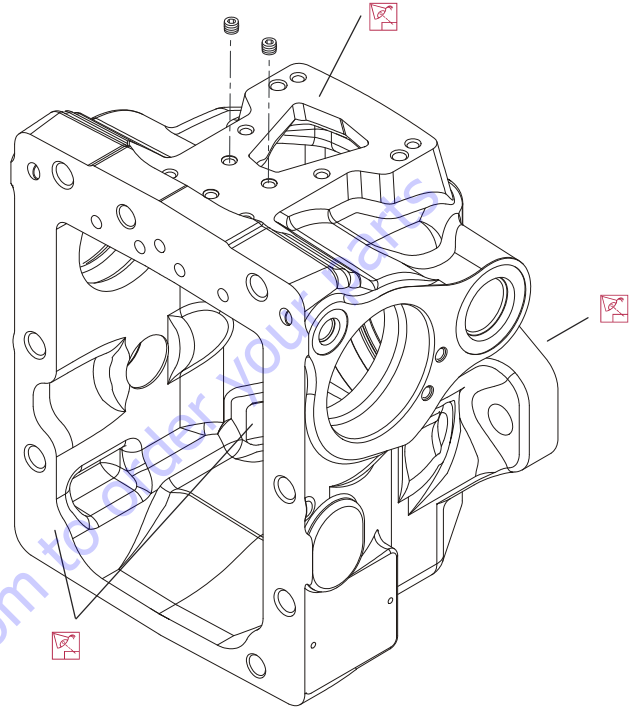

**PRESSURE LIMITER**

Pressure limiter valves are available as complete units only. If you suspect valve malfunction, replace the valve(s) and test pump operation. Replace O-rings before reassembly.

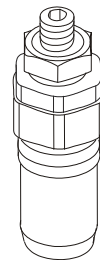

**HPRV VALVE**

HPRV valves are available as complete units only. If you suspect valve malfunction, replace the valve(s) and test pump operation. Replace O-rings before reassembly.

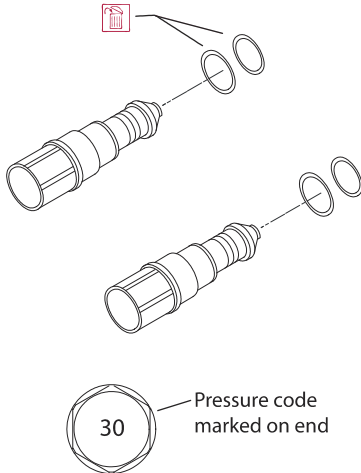

**OPTIONAL DISPLACEMENT LIMITER**

Inspect the displacement limiter screw threads. Ensure that the screw is not bent. Replace the seal/nut.

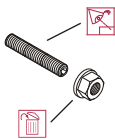

**CHARGE PRESSURE RELIEF VALVE**

Charge pressure relief valve is available as a complete unit only. If you suspect valve malfunction, replace the valve and test pump operation. Replace O-rings before assembly.

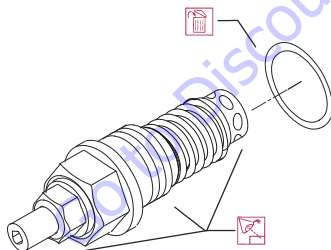

**SERVO PISTON ASSEMBLY**

**NOTE:** Do not disassemble servo piston assembly. Replacement servo piston assembly is available as a complete unit only.

Inspect slider block for wear or damage. Replace if necessary. Inspect springs for warping or cracking. Replace entire assembly if springs are damaged. Inspect servo piston for wear, cracks, or damage. Replace entire assembly if servo piston is damaged.

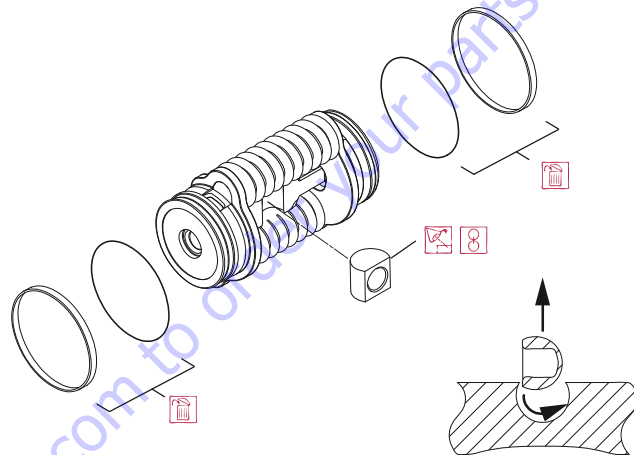

**CONTROL**

**NOTE:** If you suspect a coil malfunction, remove the coil by removing the plastic nut with a 26 mm 12 point socket. Install a new coil. Torque nut to 5 Nm [3.7 ft.lbs.].

Inspect sealing surfaces of control. If you find nicks or scratches that may allow fluid leakage, replace control. Inspect feedback spring and linkage. Control is available as a complete unit only. If you suspect control operation problems, replace control with a new unit and test pump. If necessary, you may remove and clean the control orifices. Use a 3 mm internal hex. wrench Torque to 2.5 Nm [1.8 lb.ft.]. Remove and replace the screen if contaminated. Screen is not serviceable.

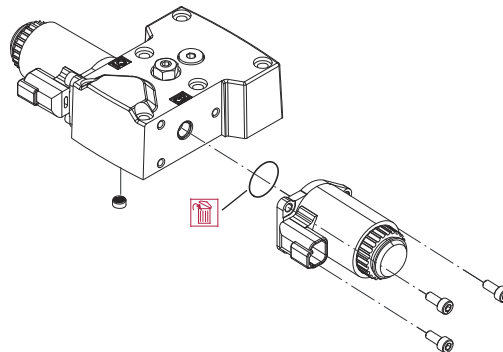

## Assembly

### SHAFT AND SEAL INSTALLATION

1. Orient pump with the mounting flange pointing up.
2. Using an adequate press, press the bearing (J150) onto the shaft (J100) and install the retaining ring (J200). Ensure the retaining ring diameter is less than 38.84 mm [1.53 in] once installed on the shaft.

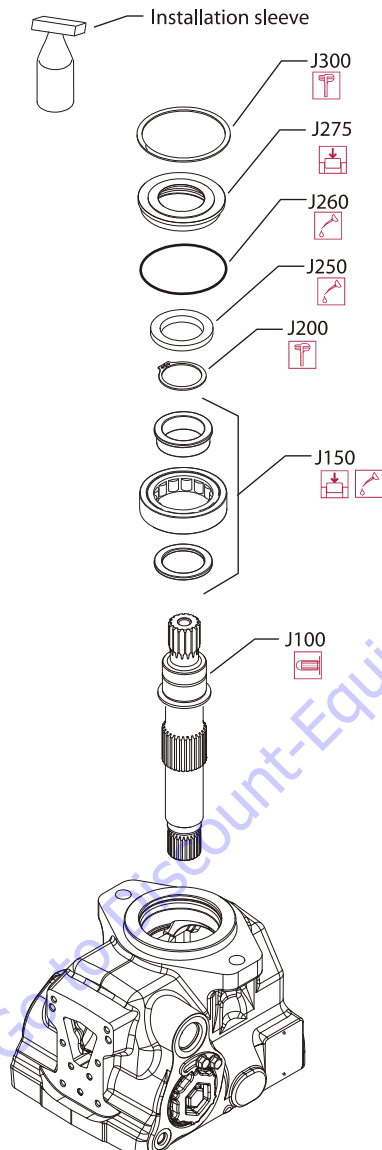

3. Lubricate and install a new O-ring (J260) onto seal carrier (J275). Press a new seal (J250) into the seal carrier so the solid side of the seal is against the shoulder of the seal carrier.

**NOTE:** Seal does not need to be flush with surface of seal carrier. Top of seal may be 0.12 mm [0.005 in] above surface or 0.72 mm [0.028 in] below surface of seal carrier.

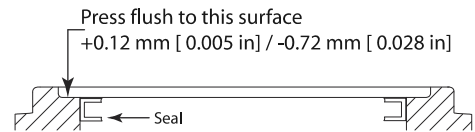

4. Install the shaft assembly into the front housing. Cover the shaft with an installation sleeve to protect it during installation of the seal carrier.
5. Hand press the seal carrier (J275) into the housing. Ensure the seal carrier clears the spiral ring groove in the housing. Remove protective cover from shaft end.
6. Install the spiral ring (J300) into the housing. The inside diameter of the ring must be at least 68 mm [2.677 in] after installation.

### SWASHPLATE BEARINGS AND SWASHPLATE INSTALLATION

1. Position housing with front flange pointing down.

**NOTE:** Always replace swashplate bearings (D075).

2. Coat swashplate bearings (D075) with hydraulic fluid and install them onto the swashplate (D070). The inner race of the swashplate bearing clips onto the swashplate.

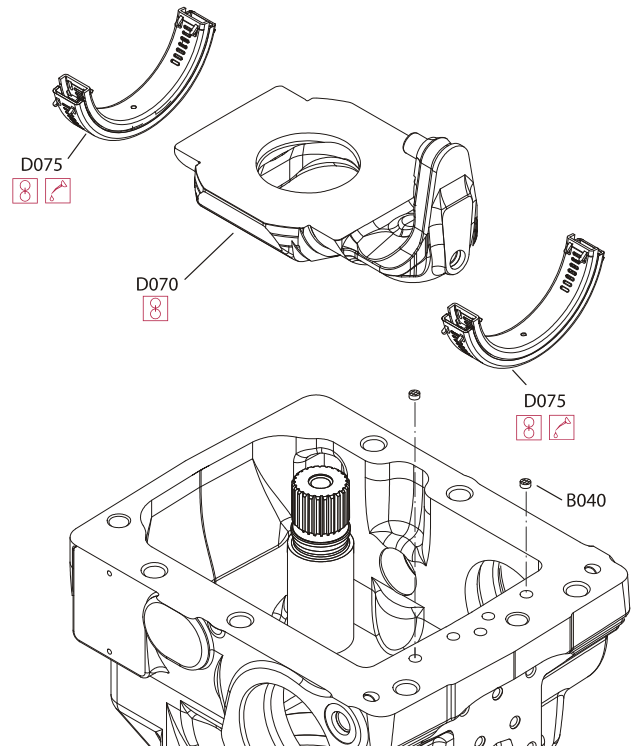

3. Install the swashplate and bearings into the housing. Ensure swashplate is in neutral position.
4. If removed, install new filter screens (B040) into housing. Install screens in same orientation as when removed.

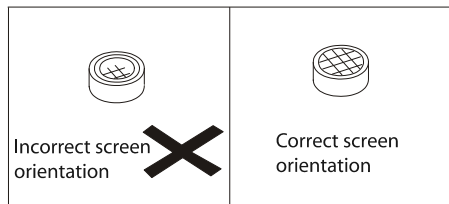

**SERVO PISTON REASSEMBLY**

1. Lubricate and install new piston seals and O-rings (E025). Stretch O-rings onto servo piston, then install piston seals outboard of the O-rings. Allow seals to relax before installing servo piston. Use the servo cylinder to resize the seals before installing servo piston.

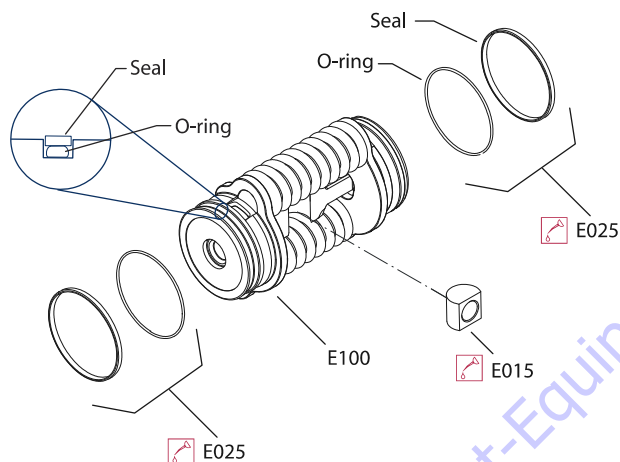

2. Lubricate and install slider block (EOT 5).

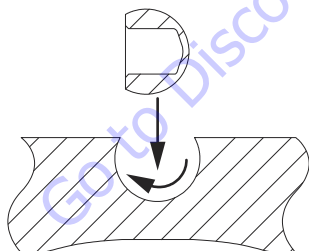

**SERVO PISTON INSTALLATION**

Install servo piston assembly (E100). Ensure swashplate pin fits properly in servo slider block (EOT5).

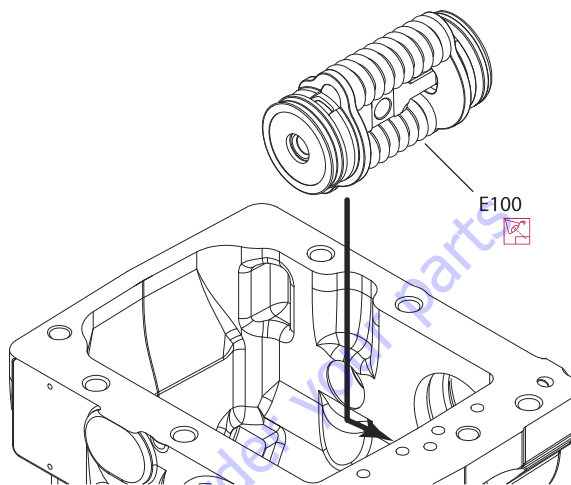

**SERVO CYLINDER INSTALLATION**

1. Lubricate new O-rings (E250) and install on each servo cylinder.

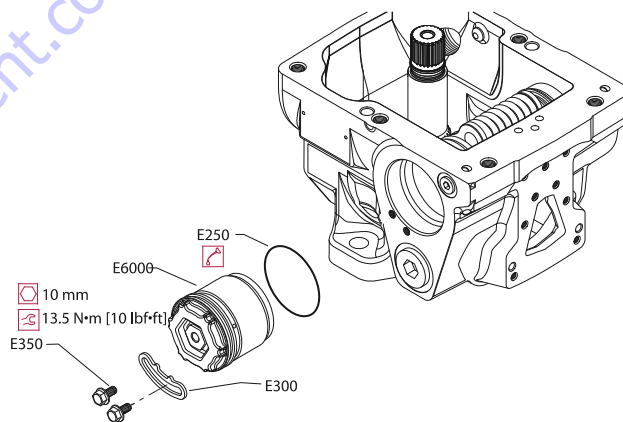

2. While holding the servo piston in place, thread servo cylinders into housing using a 3/4 in socket. Thread cylinders equal distance in each side of pump until each cylinder contacts servo cylinder. Do not compress servo piston spring.

**⚠ CAUTION**

**DO NOT ALLOW LOOSE SERVO PISTON TO DAMAGE INTERNAL MACHINED SURFACES OF PUMP.**

**DO NOT DAMAGE SEALS WHEN INSTALLING SERVO CYLINDERS.**

3. Install locking plates (E300). Using a 10 mm wrench, install locking plate screws (E350). Torque screws to 13.2-16.1 Nm [9.7-11.9 lb.ft.].

**NOTE:** After pump assembly is complete, mount pump on test stand. Perform mechanical neutral adjustment and control neutral adjustment. Refer to HI Closed Circuit Axial Piston Pumps 078/147/165 Service Manual 520L0848 for adjustment procedures.

**CYLINDER KIT REASSEMBLY**

1. Coat all parts with hydraulic fluid prior to reassembly.

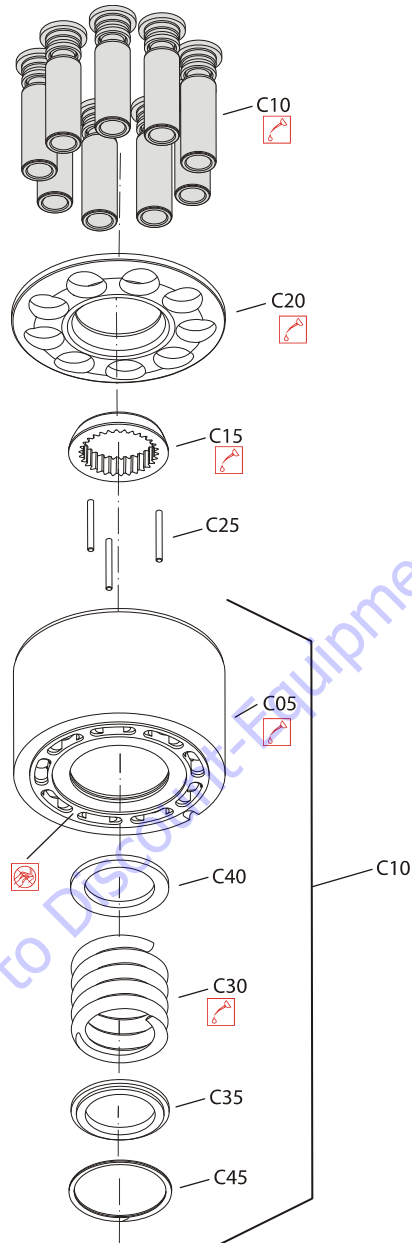

2. Install the inner block spring washer (C40), block spring (C30), and outer washer (C35) into the cylinder block. Using a press, compress the block spring enough to expose the retaining ring groove. Wind the spiral retaining ring (C45) into the groove in the cylinder block.

**⚠ WARNING**

**RISK OF PERSONAL INJURY: COMPRESSING THE BLOCK SPRING REQUIRES ABOUT 350 TO 400 N [80 TO 90 LB.F.]. USE A PRESS SUFFICIENT TO MAINTAIN THIS FORCE WITH REASONABLE EFFORT. ENSURE THE SPRING IS SECURE BEFORE ATTEMPTING TO INSTALL THE SPIRAL RETAINING RING. RELEASE THE PRESSURE SLOWLY AFTER THE RETAINING RING IS INSTALLED.**

3. Turn the block over and install the hold-down pins (C25) and ball guide (C15) into the cylinder block.
4. Insert the pistons (C10) into the slipper retainer (C20). Install the piston/retainer assembly into the cylinder block. Ensure the concave surface of the retainer seats on the ball guide. If you are reusing the pistons, install them to the original block bores. Lubricate the pistons, slippers, retainer, and ball guide before assembly. Set the cylinder kit aside on a clean surface until needed.

**NOTE:** Be sure to install the slipper retainer (C20) so it mates correctly with the ball guide (C15) (concave side of the slipper retainer against the convex side of the ball guide).

**CYLINDER KIT INSTALLATION**

1. Position pump with shaft pointing down.
2. Insert the cylinder block kit onto the shaft. While holding the shaft, slightly rotate the cylinder block kit to help start the shaft splines over the ball guide and align it with the block splines.

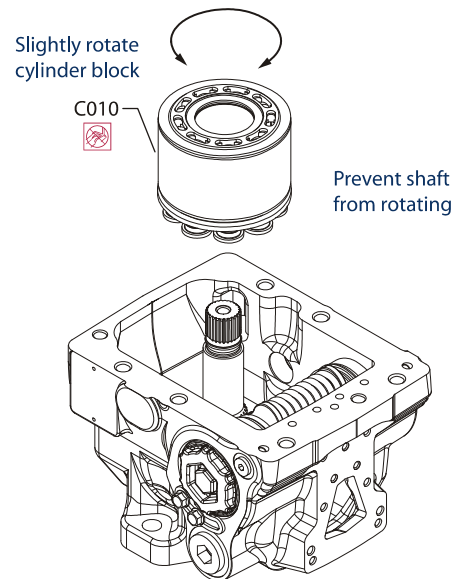

**TIMING PIN AND ENDCAP BUSHING INSTALLATION**

1. Install timing pin (C020) in endcap as shown. Orient slot away from valve plate. Install the alignment pins (B010) in housing. Measure pin insertion depth to verify proper pin insertion.

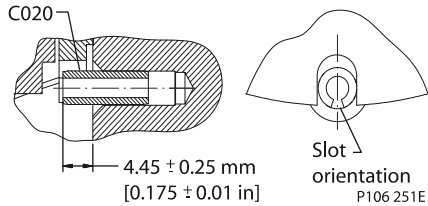

2. Orient endcap bushing slots towards top or bottom of endcap. Lubricate and press the bushings (G550) into the end cap to depth shown below.

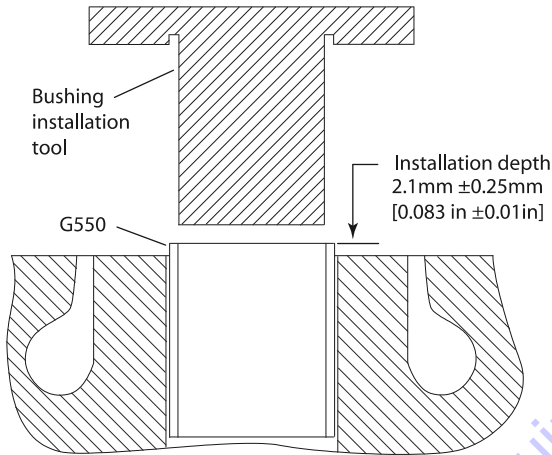

**NOTE:** Ensure that bushing is properly installed. Improper installation resulting in improper depth or misalignment will result in premature bushing and charge pump failure.

**VALVE PLATE AND ENDCAP INSTALLATION**

1. Install the alignment pins (B010) in housing.

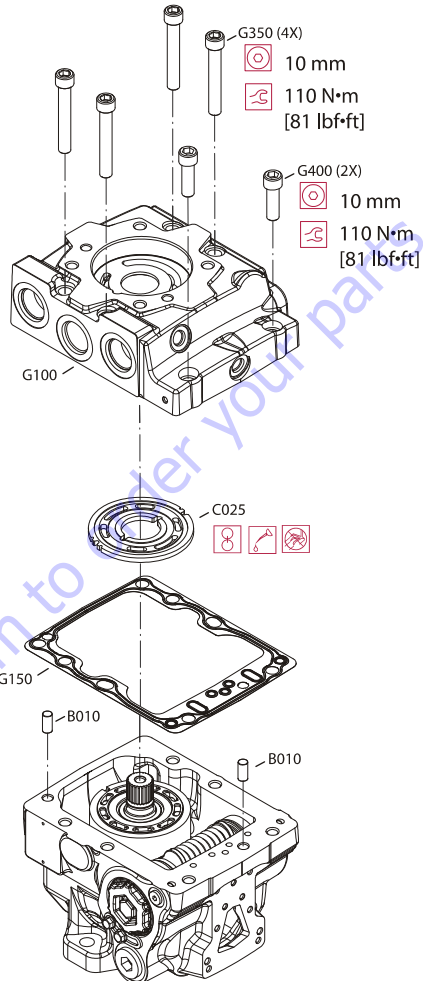

2. Clean the valve plate (C025) and endcap(G100).
3. Apply a liberal amount of assembly grease to the back-side of the valve plate surface to hold it in place and position on endcap in original position.

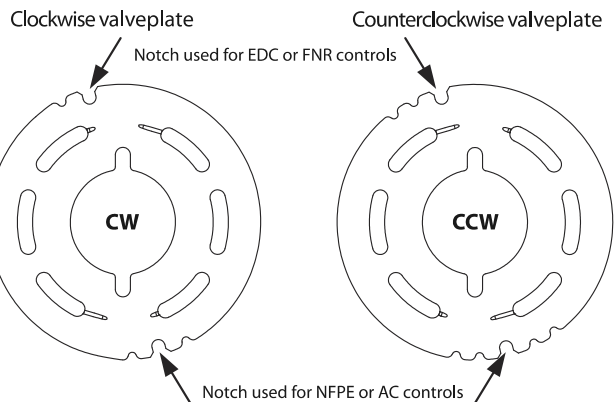



**NOTE:** For proper pump operation, it is extremely important to ensure that there is no contamination between the end cap and valve plate.

4. Install new gasket (G150).

**NOTE:** Do not bend or warp the gasket in an attempt to straighten it. This may damage the embossing which is not visible under the rubber coating.

5. Using a 10 mm internal hex wrench install endcap with cap screws (G350) and (G400).
6. Torque cap screws (G350) and (G400) to 110 Nm[81 lb.ft.].
7. Use torque sequence shown below.

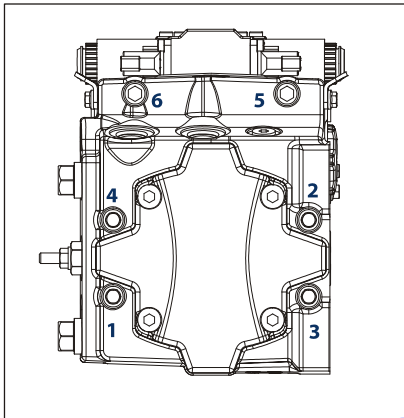

### CHARGE PUMP INSTALLATION

**NOTE:** Charge pump components are available as a complete kit only. Kit includes (S300), (S250), (S100), (S150), and (S200).

1. Install new seal (S300) to valve plate (S250). Lubricate valve plate (S250) and install in same orientation as when it was removed.

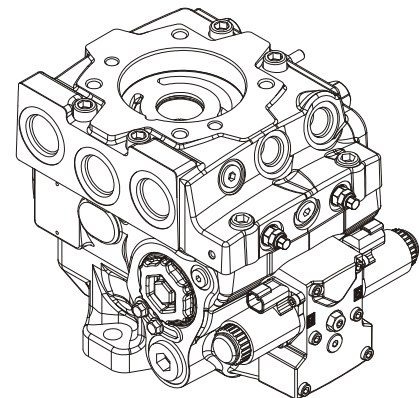
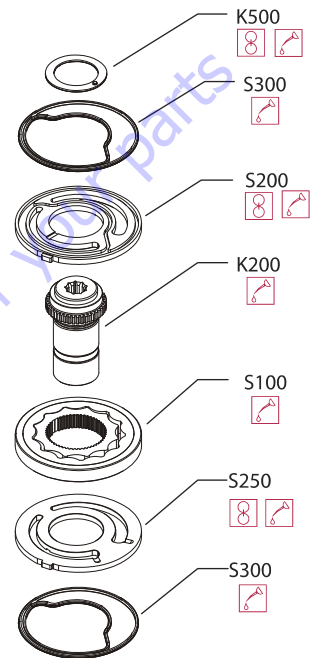

2. Lubricate and install outer ring (S150) and charge pump gear set (S100). Lubricate and install coupling (K200).
3. Lubricate and install pressure-balance plate (S200) in same orientation as when it was removed. Install new outer seal (S300).
4. Lubricate and install thrust washer (K500) in same orientation as when it was removed.

**NOTE:** Bump on thrust washer fits into hole in cover.

**END COVER INSTALLATION**

1. Install alignment pins (G450). Install gasket (K150).

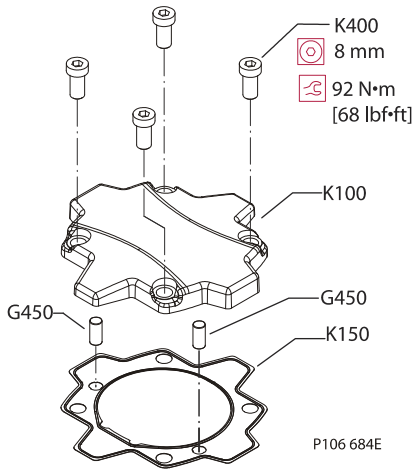

2. Install end cover with capscrews (K400) using an 10 mm internal hex wrench. Torque to 92 Nm [68 lb.ft.]. Follow torque sequence below.

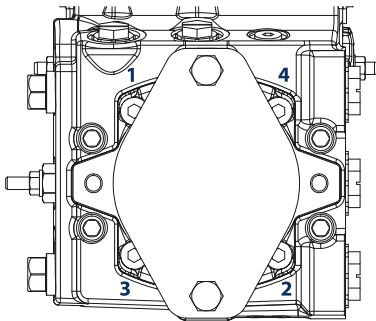

**CHARGE PRESSURE RELIEF VALVE INSTALLATION**

1. Install new O-ring (V024).

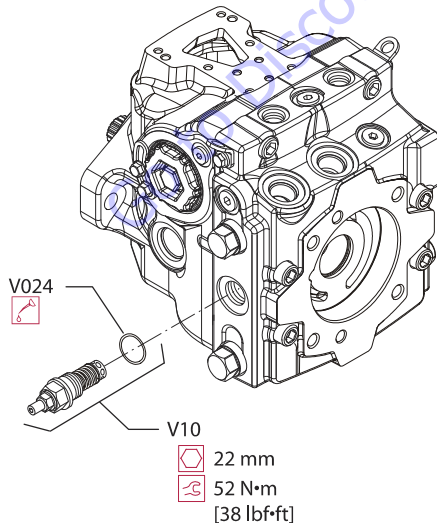

2. Using a 22 mm wrench, install the charge pressure relief valve (V10).
3. Torque to 52 Nm [38 lb.ft.].

**PRESSURE LIMITER INSTALLATION**

1. Lubricate and install O-rings (L022).

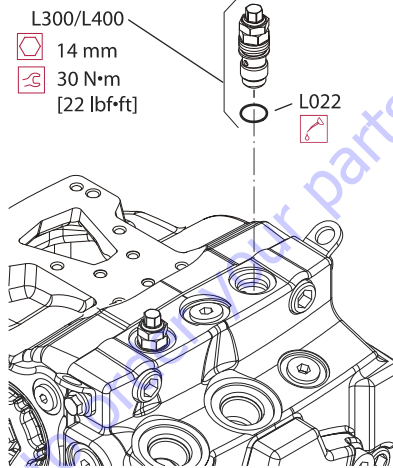

2. Using a 14 mm wrench, install pressure limiter cartridges (L300) and (L400).
3. Torque to 30 Nm [22 lb.ft.].

**HPRV VALVE INSTALLATION**

1. Replace and lubricate O-rings (L060) and backup rings (L068) before reassembly.

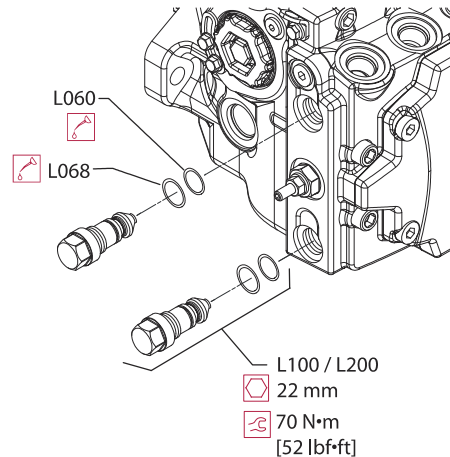

2. Using a 22 mm wrench, install HPRV valves (L100) and (L200).
3. Torque to 70 Nm [52 lb.ft.].

**OPTIONAL DISPLACEMENT LIMITER INSTALLATION**

**NOTE:** Set the approximate displacement limiter depth. See the table below for displacement change per turn. Run screw in until it contacts the servo piston, then back out the appropriate number of turns.

**Table 5-6. Displacement Limiter Adjustment Data**

Locknut wrench size and torque	Adjusting screw size	Approximate displacement change per revolution of adjusting screw
13 mm 23 Nm [17 ft.lbs.]	4 mm internal hex	5.1 cm <sup>3</sup> [0.31 in <sup>3</sup> ]

1. Thread displacement limiter adjusting screw (E450) into servo sleeve.

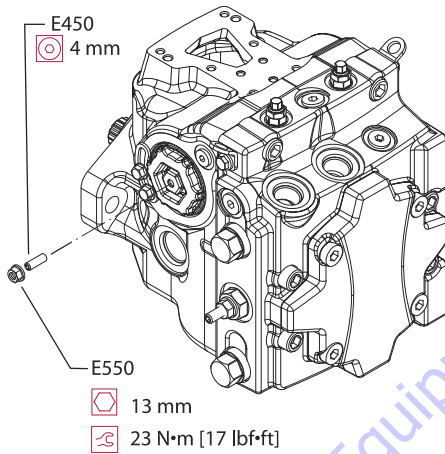

2. Thread a new locking nut onto adjustment screw. Torque to 23 Nm [17 ft.lbs.] using a 13mm hex wrench.

**EDC CONTROL ASSEMBLY**

1. Install new O-rings (D025A) into solenoids (D025), and attach solenoids with capscrews (D050) using 4 mm internal hex wrench. Torque to 8 Nm [6 ft.lbs.].

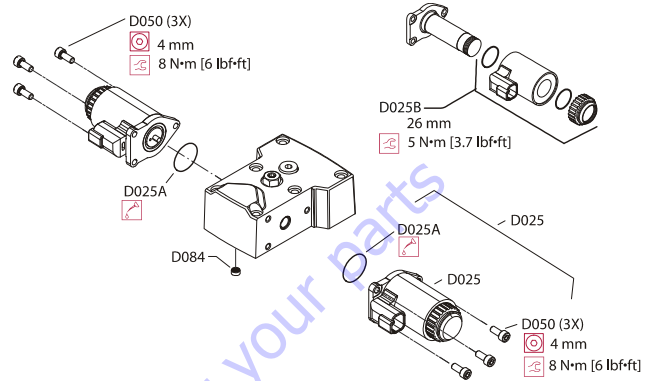

2. Replace screen (D084) if removed. Drawing shows proper screen orientation.

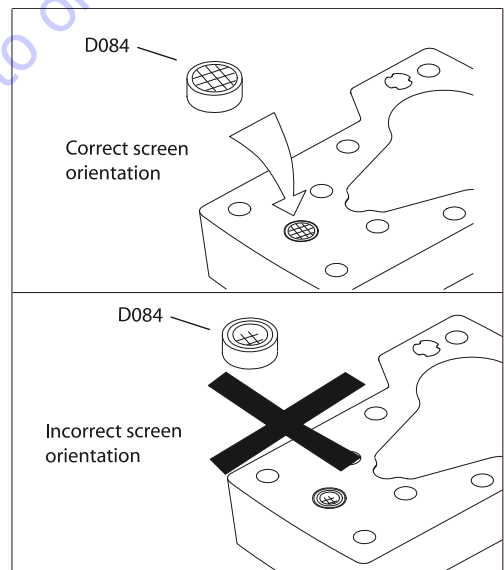

**NOTE:** If you suspect coil malfunction, remove the coil (D025B) by removing the plastic nut with a 26 mm 12 point socket. Install a new coil and torque the nut to 5 Nm [3.7 ft.lbs.].

**EDC CONTROL INSTALLATION**

1. Use a 13 mm deep well socket to install feedback pin in swashplate. Torque to 23-28 Nm [17-20 ft.lbs.]. Do not overtorque.

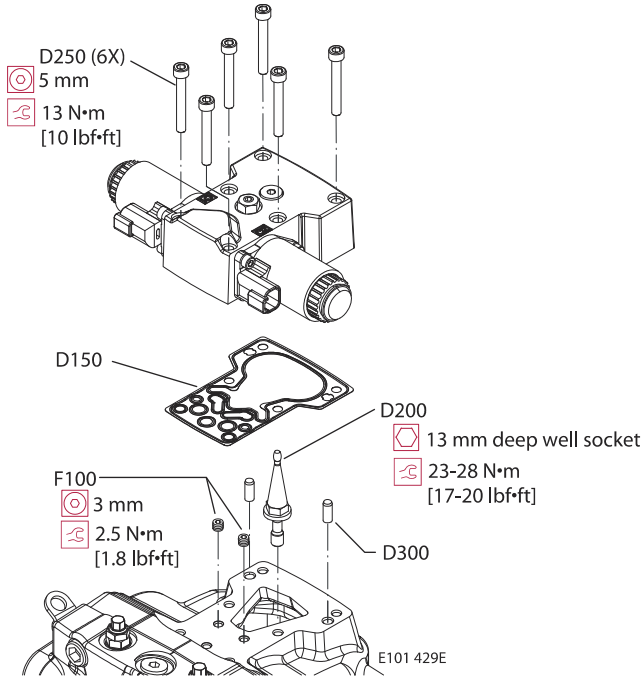

2. Install dowel pins (D300).
3. Install new gasket (D150).
4. Position control on pump housing. Remove plug on top of control to visually ensure that feedback pin on swashplate is engaged properly in control arms.
5. Using a 5 mm internal hex wrench, fasten control to pump with hex screws (D250). Torque screws to 13 Nm [10 ft.lbs.]. Follow torque sequence shown.

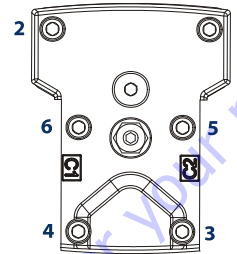

**NOTE:** If orifices (F100) were removed, reinstall using a 3 mm internal hex wrench. Torque to 2.5 Nm [1.8 ft.lbs.].

Go to Discount-Equipment.com to order your parts

**Port Locations and Gauge Installation**

pressure gauges frequently to ensure accuracy. Use snubbers to protect gauges.

**PORT LOCATIONS AND GAUGE INSTALLATION**

The following table and drawing show the port locations and gauge sizes needed. When testing system pressures, calibrate

**Table 5-7. Port information**

Port identifier	Port size	Wrench size	Pressure obtained	Gauge size, bar [psi]
L1,L2	1 1/16-12 UNF28	9/16 internal hex	Case drain	10bar[100psi]
MA,MB	9/16-18 UNF	1/4 internal hex	System pressure	600 bar [10,000 psi]
M3	9/16-18 UNF 2B	1/4 internal hex	Charge pressure	50 bar [1000 psi]
M4,M5	7/16-20 UNF 2B	3/16 internal hex	Servo pressure	50 bar [1000 psi]

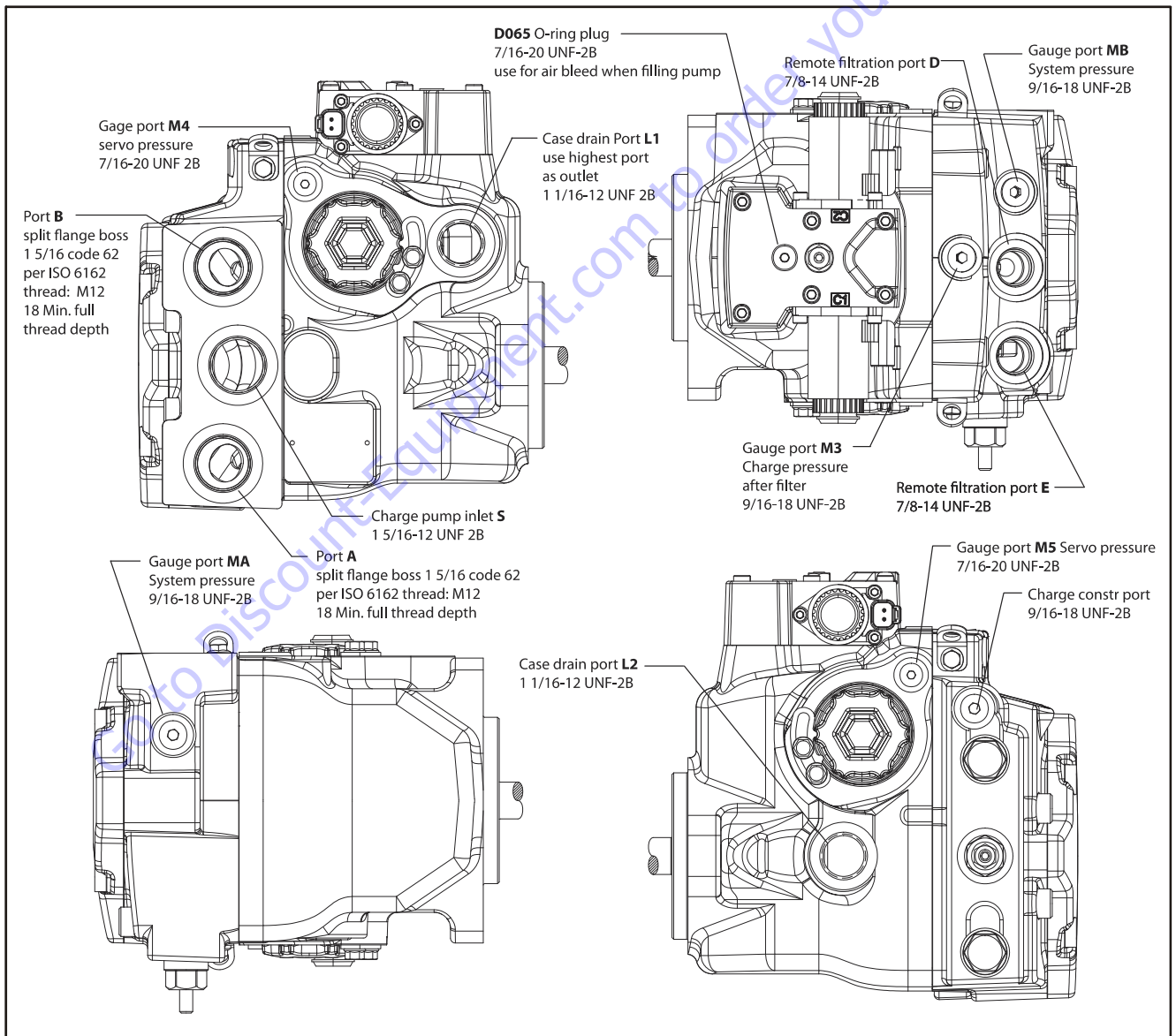

**Figure 5-31. Port Locations**

## Fastener Size and Torque Chart

Table 5-8. Fastener Size and Torque Chart

Item	Fastener	Wrench size	Torque
D015	Neutral adjust screw	4 mm internal hex	NA
D050	Coil mounting bolt	4 mm internal hex	8 Nm [9 ft.lbs.]
D060	Neutral adjust locking nut	13 mm	10 Nm [7 ft.lbs.]
D250	Electric control mounting bolt	5 mm internal hex	13 Nm [10 ft.lbs.]
E350	Servo cylinder locking bolt	Servo cylinder locking bolt	14.5 Nm [11 ft.lbs.]
K350Apad	Shipping cover mounting bolt	17mm	48 Nm [35 ft.lbs.]
K350Bpad	Shipping cover mounting bolt	18mm	77 Nm [58 ft.lbs.]
K400	Rear cover/aux pad mounting bolt	8 mm internal hex	92 Nm [68 ft.lbs.]
L010	Pressure limiter adjust screw	8 mm	NA
L300/L400	Pressure limiter cartridge	14mm	30 Nm [22 ft.lbs.]
L024	Pressure limiter locking nut	14mm	20 Nm [15 ft.lbs.]
L100/L200	High pressure relief valve	22 mm	70 Nm [52 ft.lbs.]
V10	Charge pressure cartridge	22 mm	52 Nm [38 ft.lbs.]
V020	Charge pressure adjusting screw	4 mm internal hex	NA
V022	Charge pressure locking nut	13mm	12 Nm [9 ft.lbs.]

## Plug Size and Torque Chart

Table 5-9. Plug Size and Torque Chart

Item	O-ring plug	Wrench size	Torque
B015	7/16-20	3/16 in internal hex	19 Nm [14 ft.lbs.]
B020	1-1/16-12	9/16 in internal hex	49 Nm [36 ft.lbs.]
D065	7/16-20	3/16 in internal hex	19 Nm [14 ft.lbs.]
G250	9/16-18	7 mm internal hex	22-26 Nm [16-20 ft.lbs.]
G300/G302	9/16-18 UNF	1/4 in internal hex	42 Nm [30 ft.lbs.]

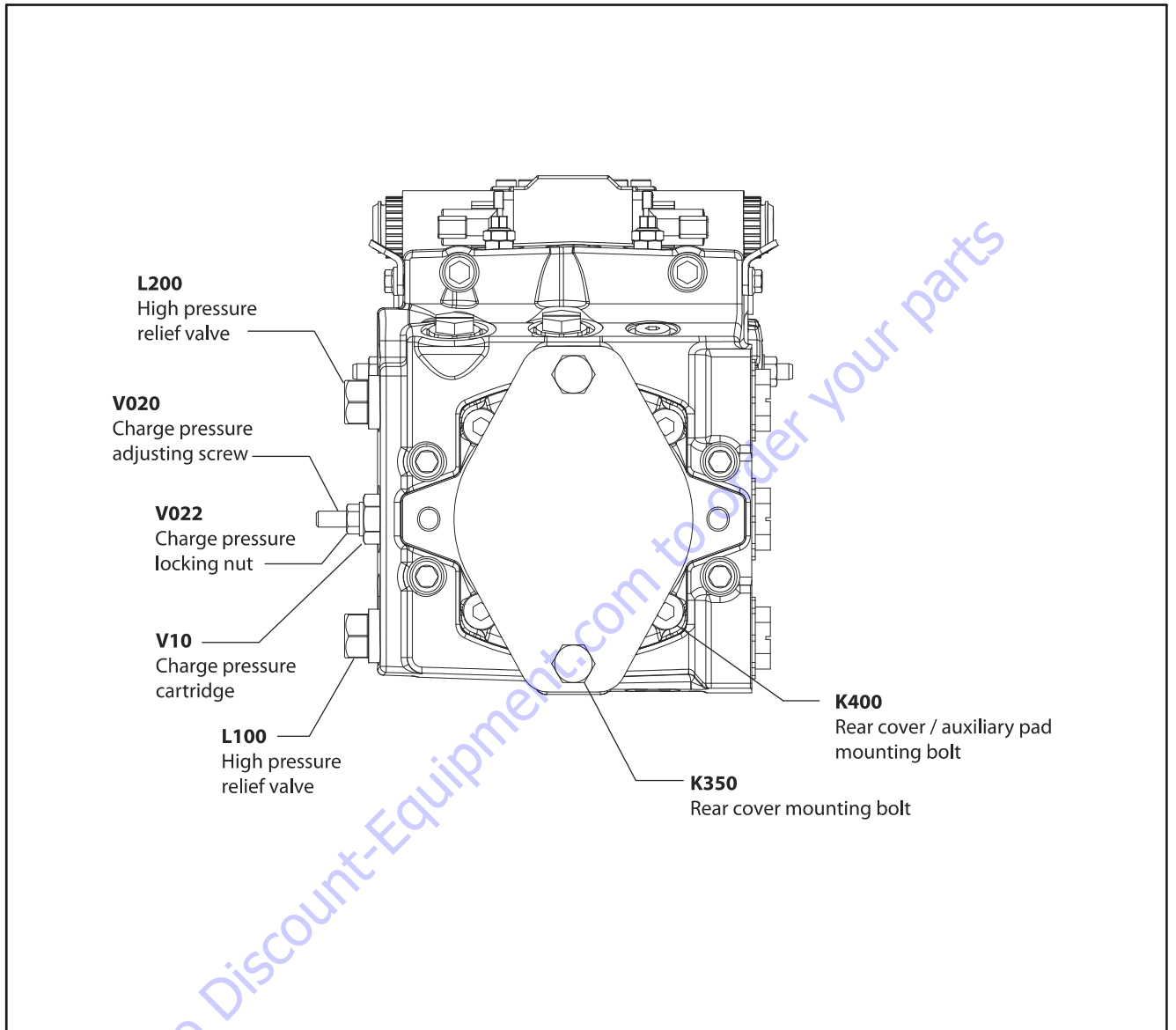
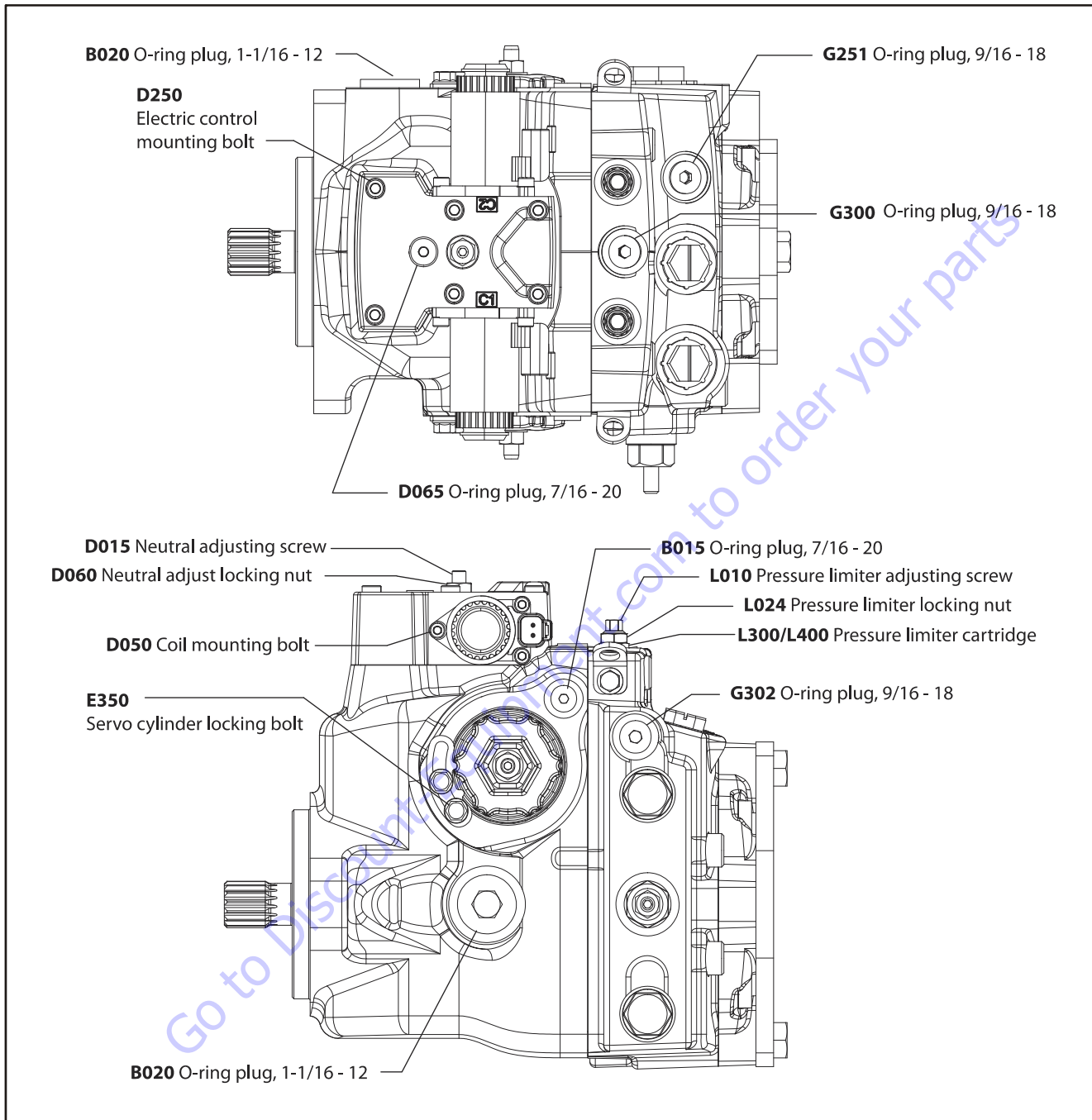

Figure 5-32. Fasteners and Plugs - Sheet 1 of 2

**SECTION 5 - BASIC HYDRAULIC INFORMATION & SCHEMATICS**



**Figure 5-33. Fasteners and Plugs - Sheet 2 of 2**



## Initial Startup Procedures

### GENERAL

Follow this procedure when starting-up a new pump installation or when restarting an installation in which the pump has been removed and re-installed on a machine. Ensure pump has been thoroughly tested on a test stand before installing on a machine.

### **⚠ WARNING**

**UNINTENDED MOVEMENT OF THE MACHINE OR MECHANISM MAY CAUSE INJURY TO THE TECHNICIAN OR BYSTANDERS. TO PROTECT AGAINST UNINTENDED MOVEMENT, SECURE THE MACHINE OR DISABLE/ DISCONNECT THE MECHANISM WHILE SERVICING.**

### PRE-FILL PROCEDURE

The case of the pump MUST be pre-filled before starting the engine. Failure to do so can cause premature failure of the pump.

1. Fill the hydraulic reservoir.
2. Locate the L2 case port on the pump. It is located on the back side facing the turntable side plate. Using a 9/16" allen wrench, remove the O-ring plug.
3. When hydraulic oil starts to flow out of this port for approximately 30 to 40 seconds, install the O-ring plug.

### START-UP PROCEDURE

Prior to installing the pump, inspect for damage that may have occurred during shipping.

1. Ensure that the machine hydraulic oil and system components (reservoir, hoses, valves, fittings, and heat exchanger) are clean and free of any foreign material.
2. Install new system filter element(s) if necessary. Check that inlet line fittings are properly tightened and there are no air leaks.
3. Install the pump. Install a 50 bar [1000 psi] gauge in the charge pressure gauge port M3.
4. Fill the housing by adding filtered oil in the upper case drain port. If the control is installed on top, open the construction plug in the top of the control to assist in air bleed.
5. Fill the reservoir with hydraulic fluid of the recommended type and viscosity. Use a 10-micron filler filter. Fill inlet line from reservoir to pump. Ensure construction plug in control is closed after filling.
6. Disconnect the pump from all control input signals.
7. Close construction plug removed in step 4.

### **⚠ CAUTION**

**AFTER START-UP THE FLUID LEVEL IN THE RESERVOIR MAY DROP DUE TO SYSTEM COMPONENTS FILLING. DAMAGE TO HYDRAULIC COMPONENTS MAY OCCUR IF THE FLUID SUPPLY RUNS OUT. ENSURE RESERVOIR REMAINS FULL OF FLUID DURING START-UP.**

**AIR ENTRAPMENT IN OIL UNDER HIGH PRESSURE MAY DAMAGE HYDRAULIC COMPONENTS. CHECK CAREFULLY FOR INLET LINE LEAKS.**

**DO NOT RUN AT MAXIMUM PRESSURE UNTIL SYSTEM IS FREE OF AIR AND FLUID HAS BEEN THOROUGHLY**

8. Use a common method to disable the engine to prevent it from starting. Crank the starter for several seconds. Do not to exceed the engine manufacturer's recommendation. Wait 30 seconds and then crank the engine a second time as stated above. This operation helps remove air from the system lines. Refill the reservoir to recommended full oil level.
  9. When the gauge begins to register charge pressure, enable, and start engine. Let the engine run for a minimum of 30 seconds at low idle to allow the air to work itself out of the system. Check for leaks at all line connections and listen for cavitation. Check for proper fluid level in reservoir.
  10. When adequate charge pressure is established (as shown in model code), increase engine speed to normal operating rpm to further purge residual air from the system.
  11. Shut off engine. Connect pump control signal. Start engine, checking to be certain pump remains in neutral. Run engine at normal operating speed and carefully check for forward and reverse control operation.
  12. Continue to cycle between forward and reverse for at least five minutes to bleed all air and flush system contaminants out of loop.
- NOTE:** *Normal charge pressure fluctuation may occur during forward and reverse operation.*
13. Check that the reservoir is full. Remove charge pressure gauge. The pump is now ready for operation.

**Troubleshooting**

This section provides general steps to follow if you observe undesirable system conditions. Follow the steps listed until you solve the problem. Some of the items are system specific. We reference the section in this manual if more information is available. Always observe the safety precautions listed in the Introduction section and precautions related to your specific equipment.

**PRECAUTIONS**

**⚠ CAUTION**

HIGH INLET VACUUM CAUSES CAVITATION WHICH CAN DAMAGE INTERNAL PUMP COMPONENTS.

**⚠ WARNING**

ESCAPING HYDRAULIC FLUID UNDER PRESSURE CAN HAVE SUFFICIENT FORCE TO PENETRATE YOUR SKIN CAUSING SERIOUS INJURY AND/OR INFECTION. RELIEVE PRESSURE IN THE SYSTEM BEFORE REMOVING HOSES, FITTINGS,

GAUGES, OR COMPONENTS. SEEK IMMEDIATE MEDICAL ATTENTION IF YOU ARE CUT

**⚠ WARNING**

UNINTENDED MOVEMENT OF THE MACHINE OR MECHANISM MAY CAUSE INJURY TO THE TECHNICIAN OR BYSTANDERS. TO PROTECT AGAINST UNINTENDED MOVEMENT, SECURE THE MACHINE OR DISABLE/ DISCONNECT THE MECHANISM WHILE SERVICING.

**⚠ CAUTION**

CONTAMINATION CAN DAMAGE INTERNAL COMPONENTS AND VOID THE MANUFACTURER'S WARRANTY. TAKE PRECAUTIONS TO ENSURE SYSTEM CLEANLINESS WHEN REMOVING AND REINSTALLING SYSTEM COMPONENTS AND LINES.

**⚠ WARNING**

HYDRAULIC FLUID CONTAINS HAZARDOUS MATERIAL. AVOID CONTACT WITH HYDRAULIC FLUID. ALWAYS DISPOSE OF USED HYDRAULIC FLUID ACCORDING TO STATE, AND FEDERAL ENVIRONMENTAL REGULATIONS.

**Table 5-10. Electrical Troubleshooting**

Item	Description	Action
Control operates pump in one direction only.	Control coil failure	Measure resistance at coil pins. Resistance should be 14.20 Ohm (24V) or 3.66 Ohm (12V) at 20×C [70×F]. Replace coil.
No pump function	No power to controller	Restore power to controller.
Erratic pump function	Electrical connection to pump is bad	Disconnect connection, check wires, reconnect wires.
Filter bypass indicator switch	Filter switch may be bad	Check/replace filter switch. Add gauge to filter bypass port to verify proper fluid flow and verify switch operation by measuring resistance, open resistance=>510 Ohm, closed resistance<=1220hm

**Table 5-11. System Operating Hot**

Item	Description	Action
Oil level in reservoir	Insufficient hydraulic fluid does not meet cooling demands of system	Fill reservoir to proper level.
Heat exchanger	Heat exchanger is not sufficiently cooling the system	Check air flow and input air temperature for heat exchanger. Clean, repair or replace heat exchanger.
Charge pressure	Low charge pressure overworks system	Measure charge pressure. Inspect and adjust or replace charge relief valve. Inspect charge pump. Repair or replace charge pump.
Charge pump inlet vacuum	High inlet vacuum overworks system. A dirty filter increases the inlet vacuum. Inadequate line size will restrict flow	Check charge inlet vacuum. If high, inspect inlet filter and replace as necessary. Check for adequate line size, length or other restrictions.
System relief pressure settings	If the system relief valves are worn, contaminated, or valve settings are too low, the relief valves get overworked	Verify settings of pressure limiters and high pressure relief valves and adjust or replace as necessary.
System pressure	Frequent or long term operation over system relief setting creates heat in system	Measure system pressure. If pressure is too high, reduce loads.

**Table 5-12. System Noise Or Vibration**

Item	Description	Action
Reservoir oil level	Low oil level leads to cavitation	Fill reservoir.
Aeration of the oil/pump inlet vacuum	Air in system decreases efficiency of units and controls. Air in system is indicated by excessive noise in pump, foaming in oil, and hot oil.	Find location where air is entering into the system and repair. Check that inlet line is not restricted and is proper size.
Cold oil	If oil is cold, it may be too viscous for proper function and pump cavitates	Allow the oil to warm up to its normal operating temperature with engine at idle speed
Pump inlet vacuum	High inlet vacuum causes noise/cavitation	Check that inlet line is not restricted and is proper size. Check filter and bypass switch.
Shaft couplings	A loose shaft coupling causes excessive noise	Replace loose shaft coupling.
Shaft alignment	Misaligned pump and prime mover shafts create noise	Align shafts.
Charge/system relief valves	Unusual noise may indicate sticking valves. Possible contamination	Clean/replace valves and test pump.

**Table 5-13. Neutral Difficult or Impossible to Find**

Item	Description	Action
Input to pump control	Input to control module is operating improperly	Disconnect input and check to see if pump comes back to neutral. If Yes, input fault, replace/repair external controller. If No, go to next step.
Pump control neutral	Neutral set improperly	Shunt servo gauge ports M4 and M5 together with external hose and see if pump comes back to neutral. If Yes: control neutral improperly set (see page 35). If no: balance swashplate (see Mechanical neutral adjustment, page 37). If you still cannot set neutral, replace control.

**Table 5-14. Sluggish System Response**

Item	Description	Action
Oil level in reservoir	Low oil level causes sluggish response	Fill reservoir.
High pressure relief valves/ pressure limiter settings	Incorrect pressure settings affects system reaction time	Adjust or replace high pressure relief valves.
Low prime mover speed	Low engine speed reduces system performance	Adjust engine speed.
Charge pressure	Incorrect pressure affects system performance	Measure and adjust charge pressure relief or replace charge pump.
Air in system	Air in system produces sluggish system response	Fill tank to proper level. Cycle system slowly for several minutes to remove air from system.
Contaminated control orifices	Control orifices are plugged	Clean control orifices.
Contaminated control screens	Control screens are plugged	Clean or replace control screens.
Pump inlet vacuum	Inlet vacuum is too high resulting in reduced system pressure	Measure charge inlet vacuum. Inspect line for proper sizing. Replace filter. Confirm proper bypass operation.

## Pump Adjustment

Read through the entire topic before beginning a service activity. Refer to Figure 5-31., Port Locations, for location of gauge ports and suggested gauge size.

### CAUTION

**CONTAMINATION CAN DAMAGE INTERNAL COMPONENTS AND VOID YOUR WARRANTY. TAKE PRECAUTIONS TO ENSURE SYSTEM CLEANLINESS WHEN REMOVING AND REINSTALLING SYSTEM LINES**

1. With the prime mover off, thoroughly clean the outside of the pump.
2. If removing the pump, tag each hydraulic line. When you disconnect hydraulic lines, cap them and plug each open port to prevent contamination.
3. Ensure the surrounding area is clean and free of contaminants like dirt and grime.
4. Inspect the system for contamination.
5. Check the hydraulic fluid for signs of contamination: oil discoloration, foam in the oil, sludge, or metal particles.
6. If there are signs of contamination in the hydraulic fluid, replace all filters and drain the hydraulic system. Flush the lines and refill the reservoir with the correct filtered hydraulic fluid.
7. Before re-installing the pump, test for leaks.

## CHARGE PRESSURE RELIEF VALVE ADJUSTMENT

**NOTE:** *Ensure charge pressure is properly set before checking pressure limiter.*

1. Install a 50 bar [1000 psi] pressure gauge in charge pressure gauge port M3. Install a 10 bar [100 psi] gauge at case pressure port L1, L2, or L3. Operate the system with the pump in neutral (zero displacement) when measuring charge pressure.
2. The table shows the acceptable pump charge pressure range for some nominal charge relief valve settings (refer to model code located on serial number plate). These pressures assume 1800 min<sup>-1</sup> (rpm) pump speed and a reservoir temperature of 50°C [120°F], and are referenced to case pressure.

**NOTE:** *Listed pressures assume a pump speed of 1800 rpm and charge flow of 26.5 l/min [7 US gal/min]. At higher pump speeds or higher charge flows the charge pressure will rise over the rated setting.*

3. Rotate the adjusting screw clockwise to increase the setting; counter clockwise to decrease it. Subtract the case pressure reading to compute the actual charge pressure.

**NOTE:** *Pressure change per turn is dependant on charge flow entering pump.*

4. While holding the adjusting screw, torque locknut to 17 Nm [13 lb.ft.].
5. When you achieve the desired charge pressure setting, remove the gauges and plug the ports.

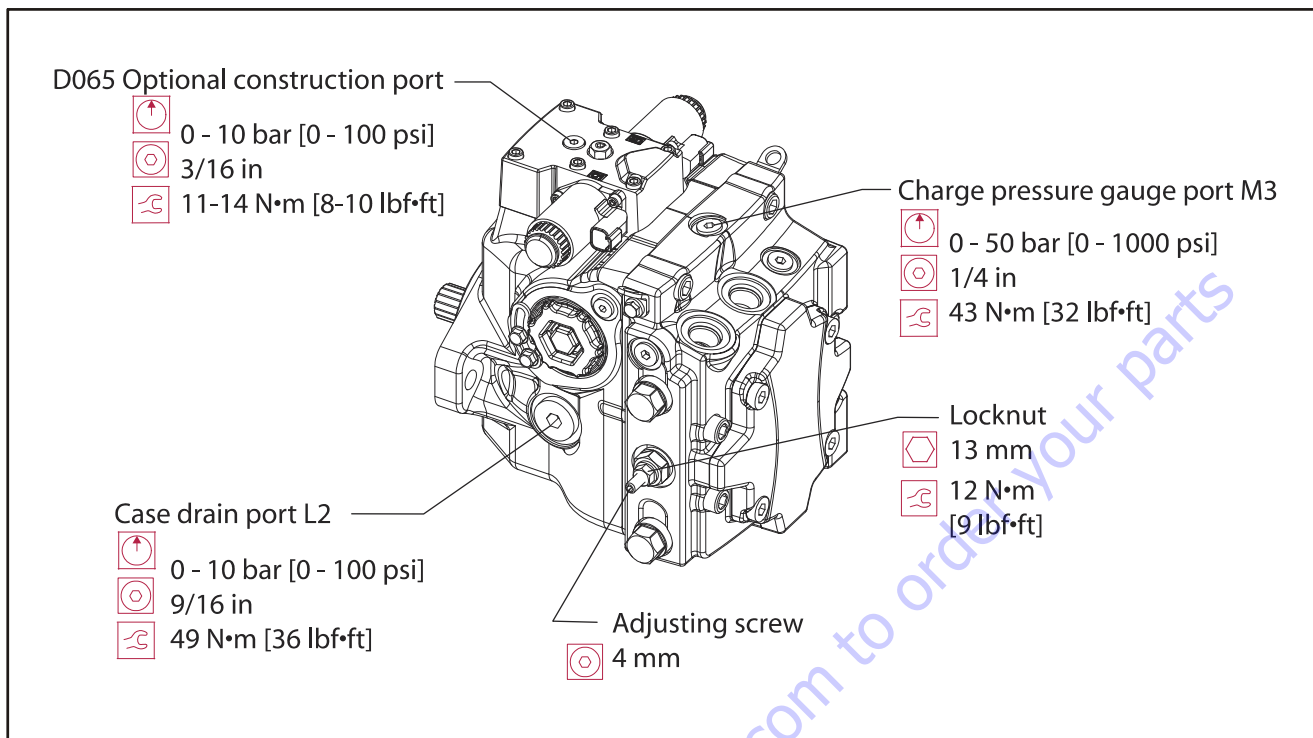

Figure 5-34. Charge Pressure Adjustment

### PRESSURE LIMITER ADJUSTMENT

Lock motor output shaft to adjust the pressure limiter setting. Lock the vehicle's brakes or rigidly fix the work function so it cannot rotate.

**NOTE:** Ensure charge pressure is properly set before checking pressure limiter.

**NOTE:** If you change pressure limiter settings, you must also change the HPRV valve to maintain proper PL function. Refer to the table for corresponding settings.

1. Install 600 bar [10,000 psi] pressure gauges in the high pressure gauge ports (MA and MB). Install a 50 bar [1000 psi] pressure gauge in the charge pressure gauge port (M3).

**NOTE:** The model code on the serial plate gives the factory setting of the PL (Pressure Limiter). The PL setting is referenced to charge pressure. Subtract charge pressure from system pressure gauge readings to compute the effective PL setting.

2. Start the prime mover and operate at normal speed.
3. Use a 17mm wrench to loosen the locking nut (L024).
4. Activate the control input until pressure in the high side of the system loop stops rising. This pressure is the PL setting.
5. Return the pump to neutral and adjust the PL setting using an internal hex wrench. Wrench size is in the diagram on the previous page. Turn the adjusting screw clockwise to increase the PL setting, counter clockwise to decrease it. The adjustment is very sensitive. Change per turn is approximately 150 bar [2176 psi].

**NOTE:** Change per turn is 150 bar/rev [2176 psi/rev].

6. Repeat steps four and five until you reach the desired PL setting. After adjustment, torque the locknut (L024) to 12 Nm [9 ft.lbs.]. Do not over torque.
7. Shut down the prime mover. Remove gauges and replace plugs.

**Table 5-15. Pressure Limiter Settings**

Pressure limiter setting	HPRV setting
150	200
180	230
200	250
230	280
250	300
280	330
300	350
330	380

**Table 5-15. Pressure Limiter Settings**

Pressure limiter setting	HPRV setting
350	400
380	420
400	450
410	
420	
430	480
440	
450	
460	510
470	
480	

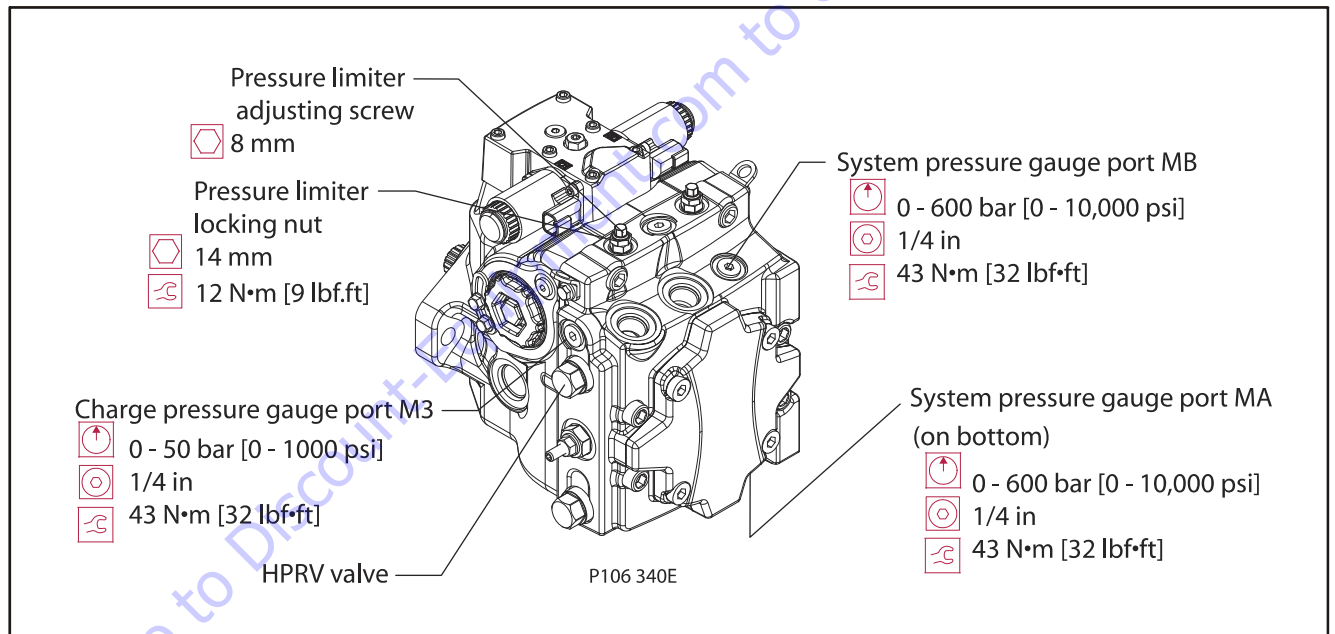

**Figure 5-35. Pressure Limiter Adjustment**

### Displacement Limiter Adjustment

If your pump has displacement limiters, you will find them on either servo cover. You can limit forward and reverse displacement independently.

**NOTE:** Displacement limiters are not pre-set by the factory. We install them as far as possible without contacting the servo piston. Limiting displacement requires clockwise adjustment of the limiting screw.

**CAUTION**

BEFORE ADJUSTING THE DISPLACEMENT LIMITER, MARK THE POSITION OF THE SERVO CYLINDER. BE SURE THE SERVO CYLINDER DOES NOT TURN WHEN SETTING THE DISPLACEMENT LIMITER LOCKNUT.

1. Loosen the locking nut.

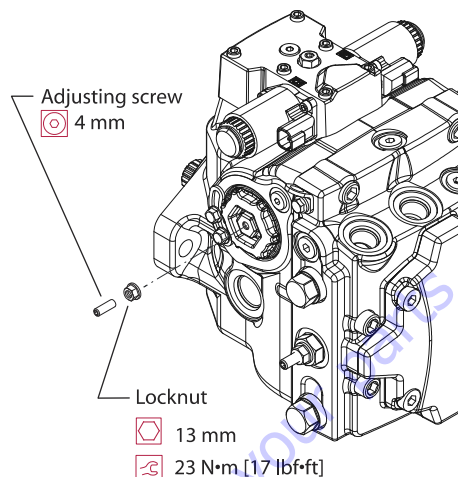

2. Rotate the adjusting screw to achieve the desired maximum displacement. Set the adjusting screw against the servo piston by feel before counting turns. Refer to the table below for change per turn. Clockwise rotation decreases displacement, counter clockwise rotation increases it. Adjustment is possible from zero to maximum.
3. After establishing the desired maximum displacement setting, hold the adjusting screw while torquing the locknut to the value in the table below.
4. Test operation of the vehicle/ machine to verify proper maximum speed of vehicle/work function.

Table 5-16. Displacement Limiter Adjustment Data

Displacement	Locknut wrench size and torque	Adjusting Screw Size	approximate displacement change per revolution of adjusting screw
45	13 mm 23Nm [17lb.ft.]	4 mm internal hex	5.1 cm3 [0.31 in3]
53	13 mm 23Nm [17 lb.ft.]	4 mm internal hex	6.0 cm3 [0.37 in3]



## Control Neutral Adjustment

### NOTICE

ADJUSTMENT OF THE EDC IS VERY SENSITIVE. BE SURE TO HOLD THE HEX WRENCH STEADY WHILE LOOSENING THE LOCKNUT. TOTAL ADJUSTMENT IS LESS THAN 120 DEGREES.

All functions of the Electric Displacement Control (EDC) are preset at the factory. Adjust the pump to neutral with the pump running on a test stand or on the vehicle/machine with the prime mover operating. If adjustment fails to give satisfactory results, you may need to replace the control or coils. Refer to Control Solenoids in this section.

### WARNING

UNINTENDED MOVEMENT OF THE MACHINE OR MECHANISM MAY CAUSE INJURY TO THE TECHNICIAN OR BYSTANDERS. TO PROTECT AGAINST UNINTENDED MOVEMENT, SECURE THE MACHINE OR DISABLE/ DISCONNECT THE MECHANISM WHILE SERVICING.

1. Install a 50 bar [1000 psi] gauge in each of the two servo gauge ports (M4 and M5). Disconnect the external control input (electrical connections) from the control. Start the prime mover and operate at normal speed.

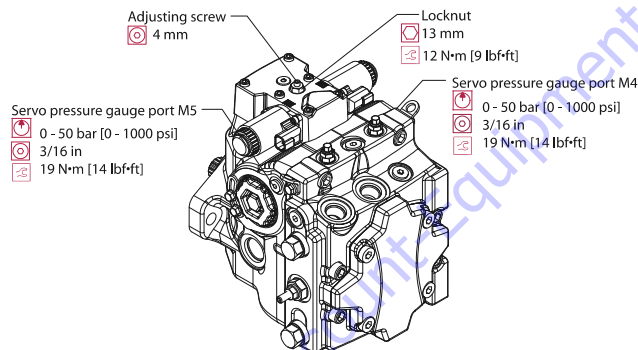

2. Use a 4mm internal hex wrench to hold the neutral adjusting screw (D015) stationary while loosening the locknut (D060) with a 13mm wrench.
3. Observe pressure gauges. If necessary, turn adjusting screw (D015) to reduce any pressure differential.

4. Rotate the neutral adjusting screw (D015) clockwise until the pressure increases on the gauge. Note the angular position of the wrench. Then rotate the neutral adjusting screw counter clockwise until the pressure increases by an equal amount on the other gauge. Again note the angular position of the wrench.

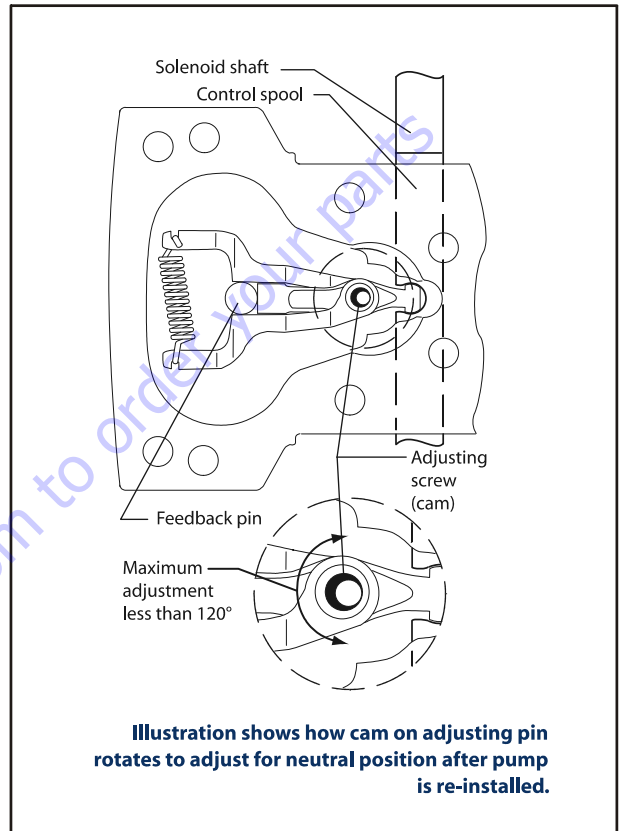

Figure 5-36. Neutral Adjustment (EDC) - Bottom View

5. Rotate the neutral adjusting screw clockwise half the distance between the wrench positions noted above. The gauges should read the same pressure, indicating that the control is in its neutral position.
6. Hold the neutral adjusting screw stationary and tighten the lock nut (D060). Torque to 10 Nm [7 lb.ft.]. Do not over torque the nut.
7. When the neutral position is set, stop the prime mover, remove the gauges, and install the gauge port plugs. Reconnect the external control input.

**NOTE:** A small pressure differential of 1.5 bar [22 psi] or less is acceptable. Zero differential is usually not possible.

## Mechanical Neutral Adjustment

### SERVO ADJUSTMENT

1. Run prime mover at 1800 min rpm.
2. If using a PWM signal, ensure the signal is off. Check the servo pressure gauges. Ensure the differential between M4 and M5 is less than 1.5 bar [22 psi].
3. Using a 3/4 in hex deep socket, unthread both servo cylinders 2-3 turns. This step ensures the servo cylinders have no contact with the servo piston.

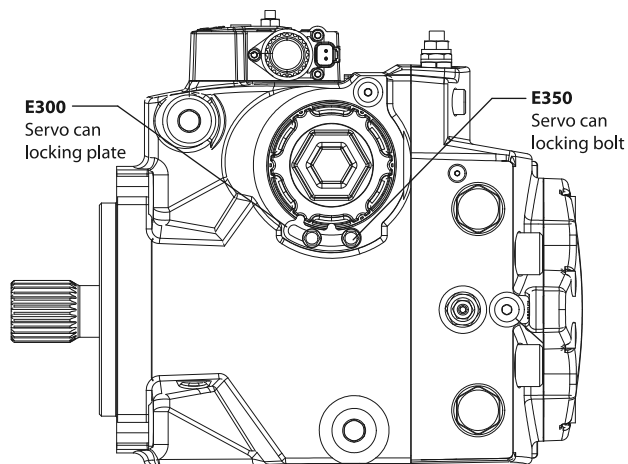

4. Stroke the pump by turning the control eccentric screw (or supplying current to solenoid C1) until the servo pressure at port M4 is 1 to 2 bar [14- 29 psi] greater than at port M5 and the system pressure gauges indicate displacement. Pressure should be greater at port MA for clockwise rotation, or MB for counter clockwise rotation. This also indicates the servo piston is in contact with the servo cylinder on side M5.
5. Slowly thread the servo cylinder on the M5 side in until the system pressure differential starts to decrease. Maintain servo pressure differential between 1-2 bar [14-29 psi] during this step. Continue turning the servo cylinder in until the system pressure differential (between ports MA/MB) is less than 1.5 bar [22 psi]. This procedure sets the servo and swashplate to mechanical neutral on the M5 side.
6. To complete setting neutral, repeat steps 1-5 but stroke the pump in the opposite direction by turning the eccentric screw in the opposite direction, or by supplying current to solenoid C2. Reverse gauge locations (M4 for M5, MB for MA) from those stated above since the pump is now stroking the other direction.

7. Remove all gauges and replace gauge port plugs. You can find wrench sizes and plug torques in the Plug size and torque chart.

### SERVO ADJUSTMENT SIDE M4

1. Run prime mover at 1800 rpm.
2. If using a PWM signal to set mechanical neutral, start with the electronic control testing tool off (no current to either solenoid). Check to be sure the servo pressure differential is less than 1.5 bar [22 psi]. Reference Control Neutral Adjustment.
3. Turn neutral adjust excenter screw (or supply current to solenoid C2) until the servo pressure at port M5 is 1 - 2 bar [14- 29 psi] greater than at port M4.
4. The system pressure differential must be greater than zero and the pressure at port A (B for clockwise rotation) must be greater than the pressure at port B (A for clockwise rotation). This step ensures the servo is in contact with the servo cylinder on side M4.
5. Slowly turn in the servo cylinder on the M4 side until the system pressure differential starts to decrease. The servo pressure differential must be maintained between 1-2 bar [14-29 psi] during this step. Continue turning in the servo cylinder until the system pressure differential is less than 1.5 bar [22 psi]. This procedure sets the servo and swashplate to mechanical neutral.

### VERIFY NEUTRAL SETTING

1. If using a PWM signal to set mechanical neutral, check that servo pressure differential is less than 1.5 bar [22 psi]. Refer to Control Neutral Adjustment.
2. To verify mechanical neutral, provide current to solenoid C1, or turn neutral adjust excenter screw, until the servo pressure differential is 3 bar [43 psi]. The system pressure differential must be below 1.5 bar [22 psi]. Repeat test on solenoid C2 side.
3. The current required to set the servo pressure differential to 3 bar [43 psi] should be the same for each solenoid. Refer to TS-392.
4. If using neutral adjust excenter screw to set mechanical neutral, reset control neutral.

## Removing the Pump

Before working on the pump, thoroughly clean the outside. If the pump has an auxiliary pump attached, remove both pumps as a single unit. Tag and cap all hydraulic lines as they are disconnected, and plug all open ports to ensure that dirt and contamination do not get into the system.

### **⚠ CAUTION**

**CONTAMINATION CAN DAMAGE INTERNAL COMPONENTS AND VOID THE MANUFACTURER'S WARRANTY. TAKE PRECAUTIONS TO ENSURE SYSTEM CLEANLINESS WHEN REMOVING AND INSTALLING SYSTEM LINES.**

### DISASSEMBLY, INSPECTION, ASSEMBLY

1. With the prime mover off, thoroughly clean all dirt and grime from the outside of the pump.
2. Tag, disconnect, and cap each hydraulic line connected to the pump. As hydraulic lines are disconnected, plug each open port, to ensure that dirt and contamination do not get into the pump.
3. Remove the pump and its auxiliary pump (if applicable) as a single unit.

**NOTE:** Be careful, do not damage solenoids and electrical connections when using straps or chains to support the pump.

4. Ensure the work surface and surrounding area are clean and free of contaminants such as dirt and grime.
5. Inspect the system for contamination.
6. Look at the hydraulic fluid for signs of system contamination, oil discoloration, foam in the oil, sludge, or metal particles.
7. Before replacing the pump, replace all filters and drain the hydraulic system. Flush the system lines and fill the reservoir with the correct, filtered hydraulic fluid.
8. Fill the pump with clean, filtered hydraulic fluid.
9. Attach the pump to the prime mover. Torque mounting screws according to the manufacturers recommendation.
10. Replace all hydraulic lines. Ensure the charge inlet line is filled with fluid.

## Electric Control Module

**NOTE:** Remove plug on top of control to ensure the swashplate feedback pin is properly positioned in the center of the control module when installing control.

### REMOVAL, INSPECTION, REASSEMBLY

Refer to Figure 5-37., Control Module Removal/Installation.

1. Using a 5 mm internal hex wrench, remove the six cap screws (D250).
2. Remove the control module and gasket (D150). Discard the gasket.
3. If necessary, remove orifices (F100) using a 3 mm internal hex wrench. Tag and number them for reinstallation.
4. Inspect the machined surfaces on the control and top of the pump. If you find any nicks or scratches, replace the component.

**NOTE:** Ensure you install dowel pins (D300) in housing before installing control.

5. Install a new gasket (D150).
6. If you removed screen (D084), install a new one. Install with the mesh facing outward (see drawing).

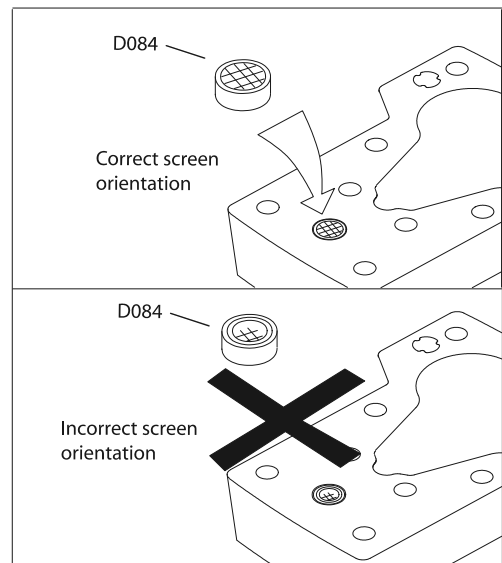

7. If previously removed, install orifices (F100) using a 3 mm internal hex wrench. Torque to 2.5 Nm [1.8 lb.ft.].
8. Install the control module and six cap screws (D250).
9. Using a 5 mm internal hex wrench, torque the cap screws (D250) to 13.5 Nm [10 lb.ft.].

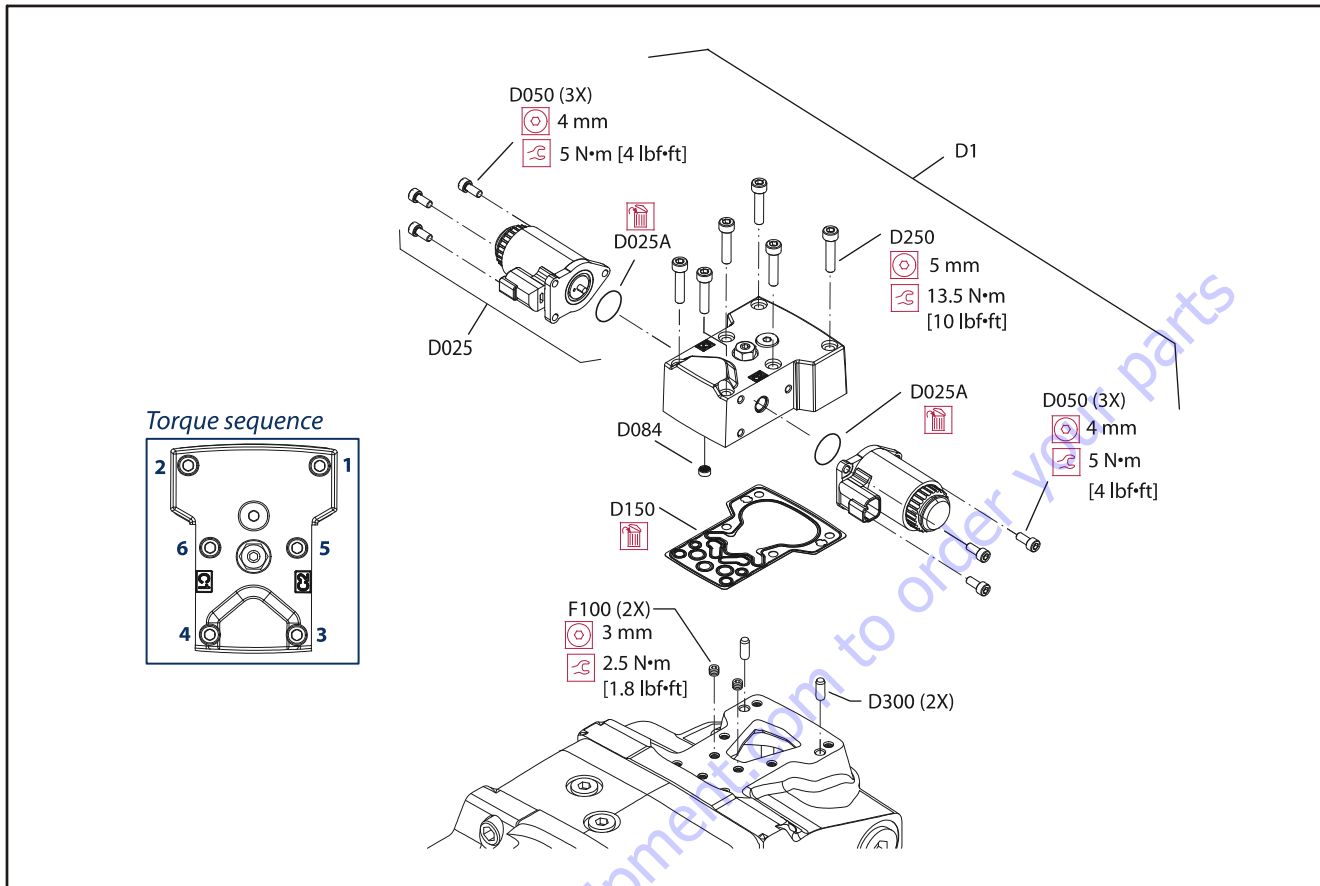

Figure 5-37. Control Module Removal/Installation

## Control Solenoids

### REMOVAL, INSPECTION, REASSEMBLY

1. Disconnect electrical connection and remove the three cap screws (D050) using a 4 mm internal hex wrench.
2. Remove the solenoid (D025) and O-ring (D025A). Discard the O-ring.
3. If necessary, remove the coil using a 12 point 26 mm socket.
4. Inspect the machined surface on the control. If you find any nicks or scratches, replace the component.
5. Lubricate new O-ring (D025A) using petroleum jelly and install.
6. Install solenoid with three cap screws (D050) using a 4 mm internal hex wrench. Torque screws to 5 Nm [4 lb.ft.].
7. Install coil using a 12 point 26 mm socket. Torque coil nut to 5 Nm [3.7 ft.lbs.].

8. Reconnect electrical connections and test the pump for proper operation.

## Shaft Seal, Roller Bearing and Shaft Replacement

### **CAUTION**

**DO NOT DAMAGE THE HOUSING BORE, SHAFT OR BEARING WHEN REMOVING THE SHAFT AND SHAFT SEAL.**

The shaft assembly is serviceable without disassembling the pump. Orient the pump on the work surface so the shaft is pointing to the side.

### REMOVAL, INSPECTION, ASSEMBLY

1. Unwind the spiral ring (J300) from the housing to release the shaft/seal/bearing subassembly.
2. Pry on the lip of the seal carrier (J275) to dislodge it from the pump. Remove the seal carrier. Remove and discard O-ring (J260). Press the seal (J250) out of the carrier and discard.

3. Pull the shaft (J100) with bearing (J150) out of the pump. If necessary, tap lightly on the shaft to dislodge it from the cylinder block. C
4. Remove the retaining ring (J200) using retaining ring pliers. Press the bearing off the shaft.
5. Inspect the shaft journals for wear, scratching, and pits. Check the splines for fretting; replace if damaged. Rotate the bearing, if it does not rotate smoothly, replace it.
6. Press the bearing (J150) onto the shaft (J100) and replace the retaining ring (J200). Ensure the retaining ring diameter is less than 38.84 mm [1.53 in] when installed on the shaft.
7. Install the shaft/bearing assembly into the pump.
8. Lubricate and install a new O-ring (J260) onto seal carrier (J275). Press a new seal (J250) into the seal carrier.

Press the seal until it is flush within +0.12mm [0.005 in] or -0.72 mm [0.028 in] of the inside lip of the carrier as shown below.

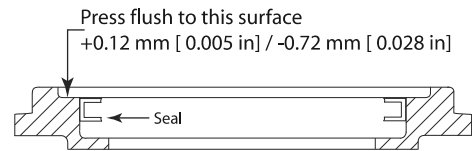

9. Cover the shaft with a protective sleeve while installing the seal carrier. Hand press the seal carrier into the housing. Ensure the seal carrier clears the spiral ring groove in the housing. Remove the protective sleeve.
10. Wind the spiral ring into the housing. Ensure the inside diameter of the spiral ring is greater than 68 mm [2.677 in] after installation.

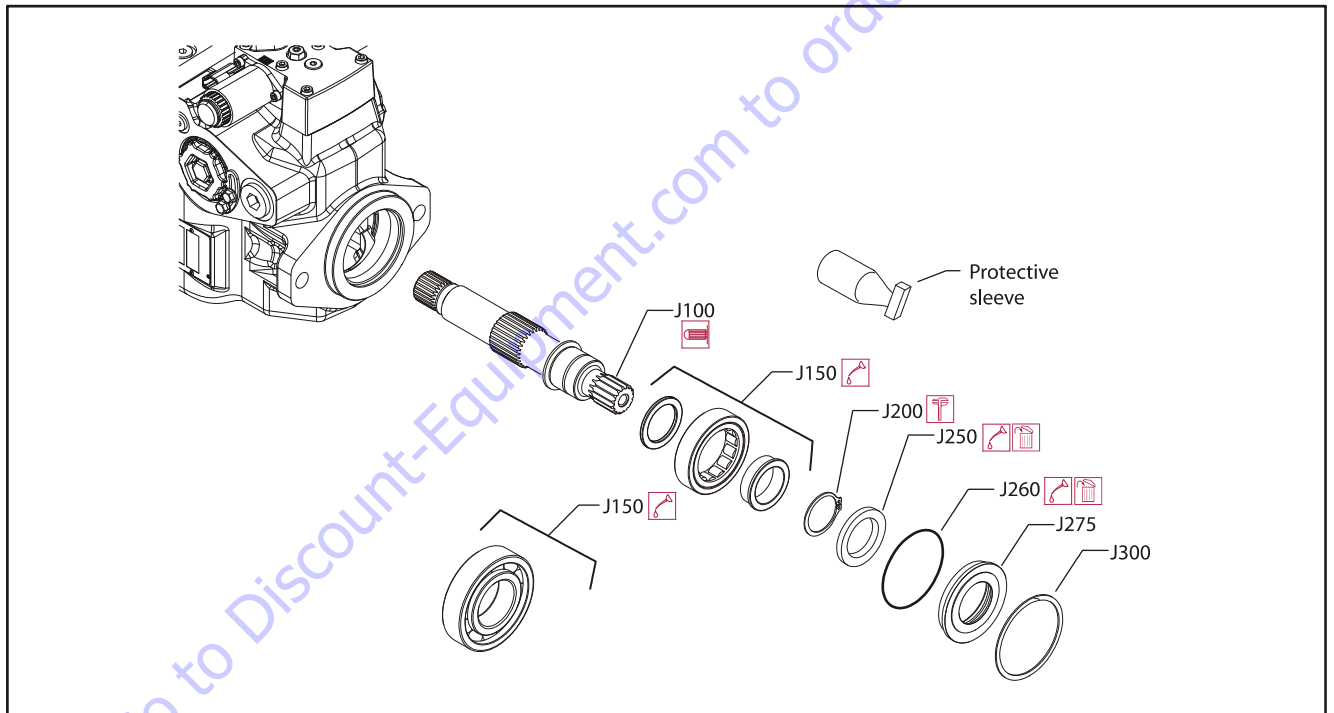
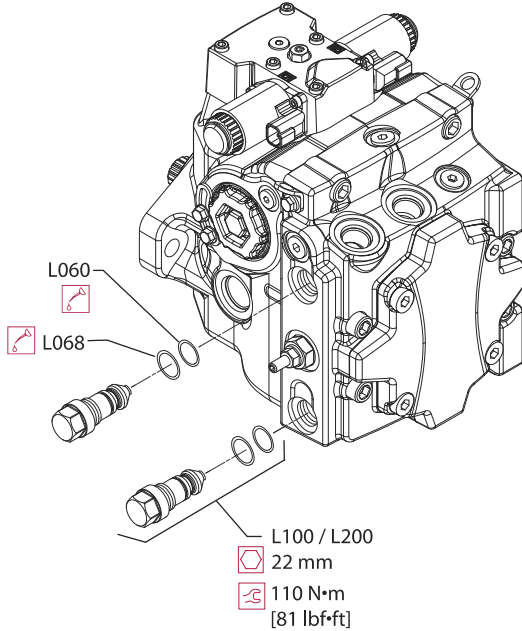

Figure 5-38. Shaft assembly

## Charge Check / HPRV

### REMOVAL, INSPECTION, ASSEMBLY

- Using a hex wrench shown in the table below, remove the HPRVs (L1 50). Remove and discard the O-rings (L060) and backup rings (L068).



- Inspect the sealing surfaces in the pump for nicks or scratches. Check the valves for damage. Replace any damaged components.
- Lubricate and install new backup rings (L068) and O-rings (L060).
- Install HPRVs. Torque to the value in the table below.
- Operate the vehicle/machine through full range of controls to ensure proper operation. Check for leaks.

## Charge Pressure Relief Valve

Replace the charge pressure relief valve (V010) as a complete unit. Do not attempt to repair the internal components of the valve. Torque to 52 Nm [38 lb.ft.]. See Charge Pressure Relief Valve Adjustment for adjustment instructions.

### REMOVAL, INSPECTION, ASSEMBLY

- Using a 22 mm wrench, remove the charge pressure relief valve (V010). Discard seal (V024).

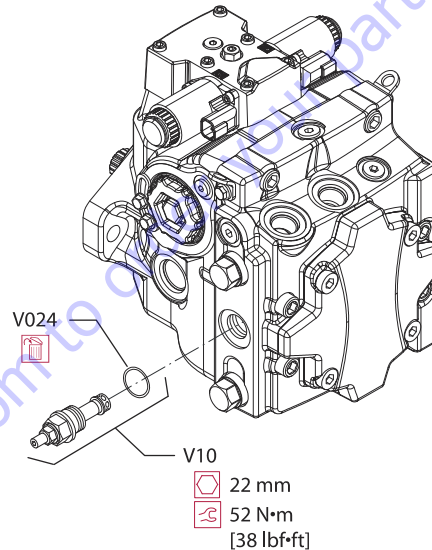

- Inspect the sealing surfaces of the pump for nicks or scratches.
- Lubricate and install new seal (V024).
- Install the charge pressure relief valve. Torque to 52 Nm [38 lb.ft.].
- Operate vehicle/machine through full range of controls to ensure proper operation.

## Pressure Limiter Valve Replacement

Replace the pressure limiter valve as a complete unit. Do not attempt to repair individual components. See Pressure limiter adjustment for adjustment instructions.

### REMOVAL, INSPECTION, ASSEMBLY

- Using a 14 mm wrench, remove the pressure limiter valve (L100). Discard O-ring.

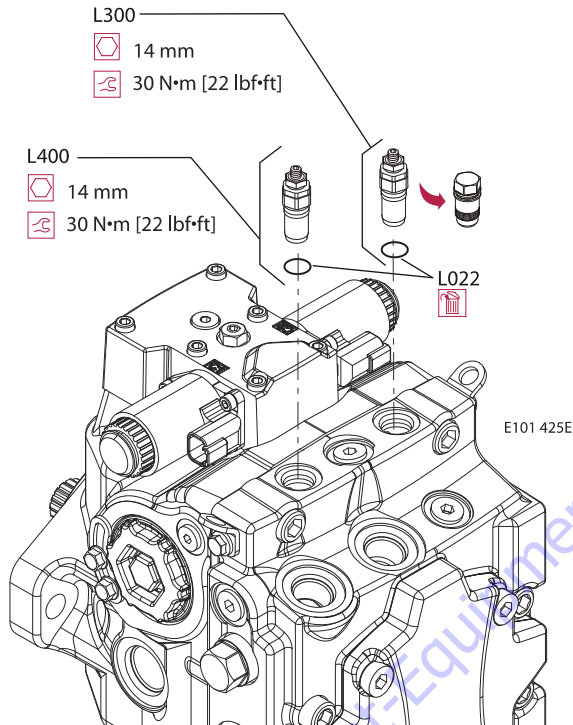

- Inspect the sealing surfaces of the pump for nicks or scratches.
- Install new O-ring. Lubricate O-ring with petroleum jelly.
- Replace pressure limiter valve. Torque to 30 Nm [22 lb.ft.].
- Operate pump at full range of controls to ensure proper machine operation. Pressure limiter is available as complete unit only. O-ring is available separately.

## 5.4 GEAR PUMP

### Disassembly

Prior to proceeding with disassembly, it may be necessary to prepare some subassemblies separately.

The details for preparing each subassembly are given in the following section.

Also, some general recommendations are given below.

### CLEANLINESS

Cleanliness is a primary factor for reliable pump performance. Wash the outside of the pump thoroughly before disassembly and all pieces prior to assembly. Cleaning parts with clean shop solvent and air drying is usually adequate.

### LUBRICATION OF MOVING PARTS

During assembly, it is imperative to provide lubrication with clean hydraulic oil to all the running parts of the pump.

It is also necessary to coat the seals with grease. The absence of lubrication during assembly can cause the unit to seize after a few minutes of running.

### CARE OF SURFACE TREATMENT

Be careful when handling all the internal surfaces, especially bearings, gears, and body faces. Do not touch or score them with metal tools or cutting edges.

### MARKING THE PARTS

Mark the parts before completely disassembling a pump. The marks allow components to be reassembled in the same relative position. This action should be applied to the body, bearings, and gears. Scribing, bluing, or using a felt tip pen to mark the outside of the body on the inlet side is suggested to indicate the relative position of the front flange and the rear cover to the body. Mark the bearing blocks also on the inlet side and the gears position relative to each other. DO NOT scribe internal surfaces.

### PROCEDURE

1. Clamp the unit.

Clamp the unit in a vice from the flange side.

Make sure the vice jaws are clean and have smooth surfaces to prevent damage to the pump.

Clamping the pump on the body is not recommended because serious damage to the surfaces, on which the ports are located, may occur.



2. Remove capscrews.

Use a 17 mm socket wrench and loosen the four capscrews on the cover. Next completely unscrew the capscrews and remove them.

Inspect the threads of the capscrews for damage.



3. Remove socket head capscrews.

Using a 4 mm internal hex wrench, loosen and remove the two small socket screws placed in the center of the cover. Repeat the same operation for the corresponding screws on the rear flange.

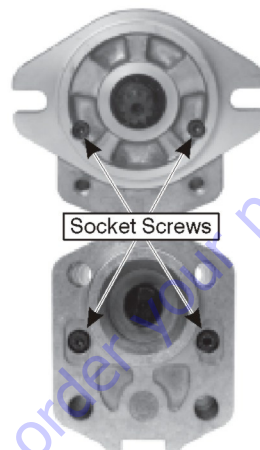



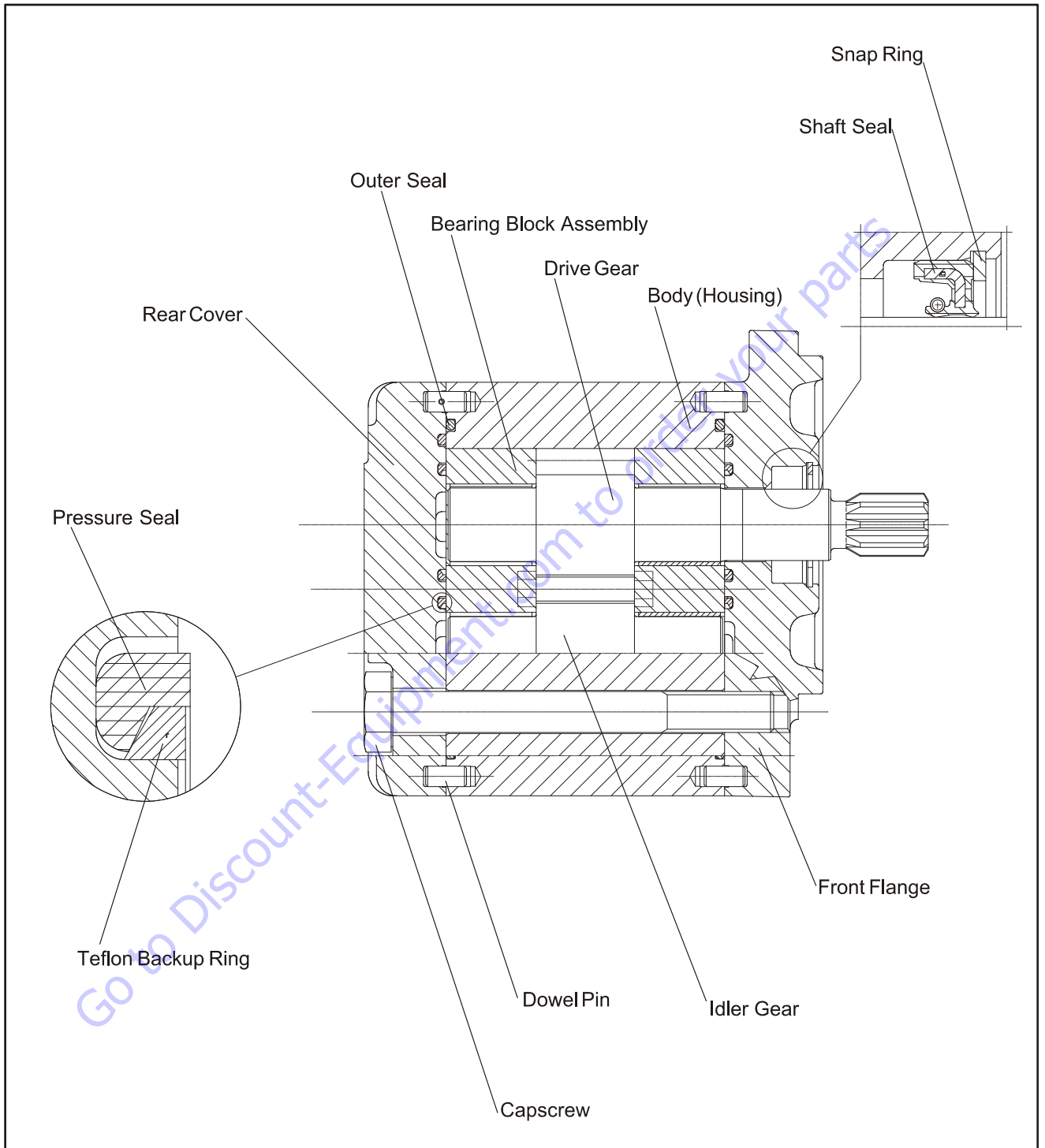

Figure 5-39. Gear Pump Cutaway

## SECTION 5 - BASIC HYDRAULIC INFORMATION & SCHEMATICS

### 4. Remove front flange.

Place the pump on the table and slowly remove the front flange.

Be careful not to damage the shaft seal when removing the flange. Avoid contact of the shaft seal lips with key-way edges (in tapered and parallel shafts) or splined shaft teeth.

Inspect the front flange and seal area.

Clean with shop solvent, dry, and set aside.

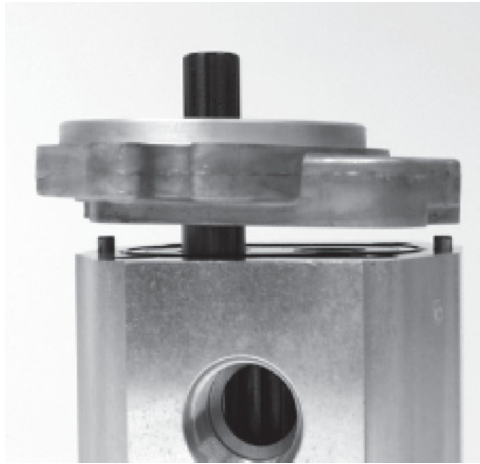

### 5. Remove rear cover.

Clean with shop solvent, dry, and set aside.

Visually inspect rear cover and seal area.

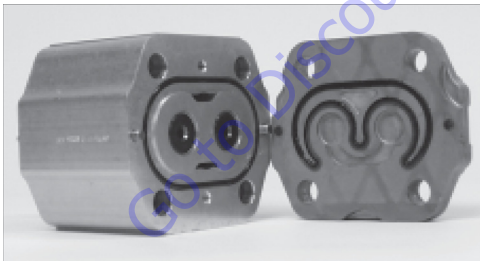

### 6. Remove bearing blocks and gears.

Place the pump on its side and carefully remove the bearing block and gear set. To accomplish this, hold the pump body and push with your fingers on the rear bearing block.

Mark the relative positions of the gear mesh (drive gear tooth to idler gear tooth) and the bearing blocks to the body so they can be reassembled in the same position.

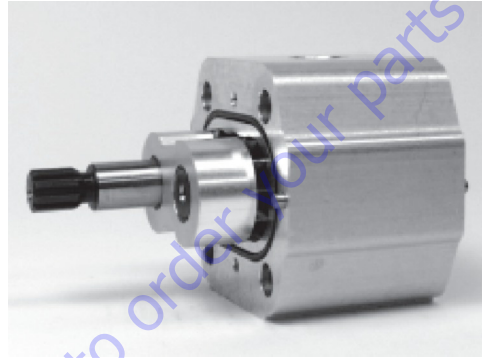

### 7. Remove pressure seals.

Check the seal quality. Replacement is recommended whenever there are burrs, evidence of extrusion, or marks caused by overheating. If the seals need to be replaced, carefully remove them from the flange cover, beginning with the backup ring and then the pressure seal.

#### **NOTICE**

**IMPORTANT: DO NOT USE TOOLS WITH SHARP EDGES TO REMOVE THE SEALS, AS DAMAGE TO THE COVER CAN RESULT.**

After removal, dispose of damaged seals.

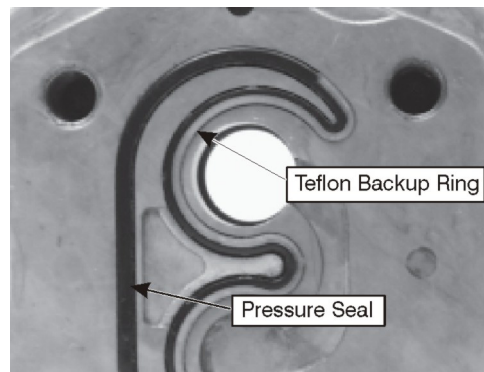

8. Remove Outer O-Ring Seal

Check the quality of this seal. If necessary, replace it. Follow the same removal recommendations given in step 7.}

After removal, discard the damaged seal.

**NOTICE**

DO NOT USE TOOLS WITH SHARP EDGES TO REMOVE THE SEALS, AS DAMAGE TO THE COVER CAN RESULT.

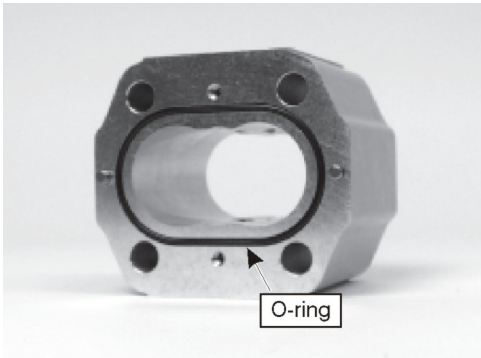

9. Remove the snap ring.

Place the flange on the work surface. Using internal snap ring pliers, remove the snap ring.



10. Remove the shaft seal.

Check the shaft seal quality and remove if necessary.

To remove, pry the bottom of the shaft seal and force it out while rotating the flange to lift it out evenly.

Do not use the flange pilot to gain leverage, damage may result. Use a plastic rod or wooden dowel as a fulcrum.

After removal, dispose of damaged seal.



**ASSEMBLY**

1. Prepare the seals.

Have the entire seal kit available.

Lightly coat all seals with seal grease. The grease is needed to adhere the seals to their grooves.

**NOTICE**

DO NOT INSTALL DRY SEALS.



**2. Install shaft seal into front flange.**

Prepare the flange and shaft seal by lightly.

lubricating with grease.

Seat the seal in the flange by hand. Then, using the shaft seal installation tool (shown on page 52), press the seal until the tool stops on the flange. This will insure the seal is inserted to the proper depth.



**3. Install snap ring.**

Install the snap ring using internal snap ring pliers. Ensure the snap ring fits securely in its groove. This is necessary to retain the shaft seal.



**4. Install pressure seals.**

Prepare the pressure seals by lightly lubricating them with grease.

Install pressure seals into the grooves on the front flange and rear cover. Then install the teflon backup ring.

Ensure that the seals are located in the grooves, as shown.

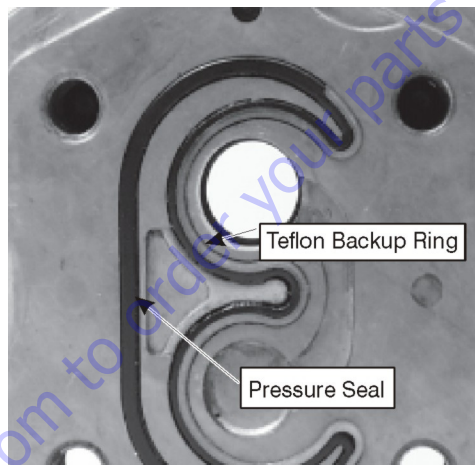

**5. Prepare the body.**

Clean the body.

Inspect the internal and mating surfaces. Ensure the surfaces are free of burrs and scratches. Check both the bearing block mating surface and the cut-in path. The cut-in path should be no deeper than 0.1 mm (0.004 in).



6. Install outer seal.

Prepare the outer seal by lightly lubricating with grease.

Install outer seals in the grooves on both sides of the body.



7. Prepare the gears.

**⚠ CAUTION**

**THE GEAR SURFACES ARE SUPERFINISHED. RESIDUE ON HANDS AND FINGERS MAY BE CORROSIVE TO THIS SURFACE. DO NOT TOUCH.**

Carefully clean the two gears. If the gears are new, wash them with shop solvent to remove any anticorrosive grease on the surfaces.

Inspect the journals and the flat faces on the top and bottom of the gears. Ensure these surfaces are free from burrs or scratches. If scratches or burrs are found, clean them with a flat stone and/or very fine emery paper. Rewash the gears after this operation.



8. Prepare the bearing blocks.

Clean the two bearing blocks.

Inspect the flat surfaces of the bearing blocks for burrs or scratches on the edges. If necessary, remove burrs with very fine emery paper. Then rewash the bearings.

Inspect the DU™ bushings for wear. There should be no bronze showing.

Using clean hydraulic oil, lubricate the internal and external surfaces of the bearing blocks.



9. Assemble the bearing blocks and gears.

Lubricate the journals and the gear faces.

Assemble the bearing blocks and gears. Ensure that the recessed bearing faces are installed adjacent to the gear faces. Align all assembly marks made during disassembly. Ensure the front and rear bearing blocks occupy the same location with respect to the housing as before disassembly. Ensure that the relative position of the gear mesh is maintained as before disassembly. Misalignment of the gear teeth may increase operating noise.



**10. Install the gear block assembly.**

Install the bearing block and gear assembly into the body cavity. Align the assembly marks to ensure that the gear block assembly is installed with the same orientation as before disassembly.

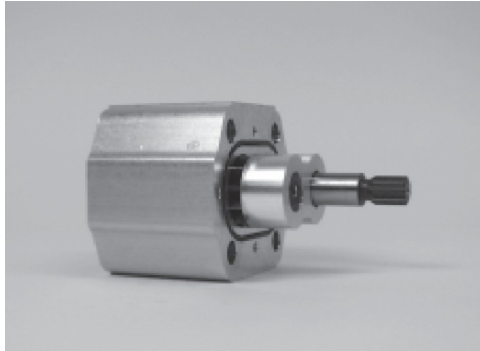

**11. Clean the mating surfaces.**

Remove any excess lubrication and grease from the mating surfaces of the pump body. Ensure that these surfaces are dry and free of contamination before moving on to the next step.

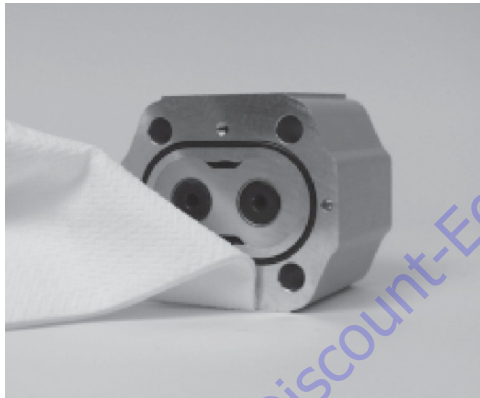

**12. Install the dowel pins.**

Install four 5 mm dowel pins into the proper cavities on both sides of the body (refer to the illustration below). Swab the pins with assembly grease or petroleum jelly to retain them during assembly.

Do not install dowel pins to the rear cover or flange, as one of them may drop inside the pump during assembly.

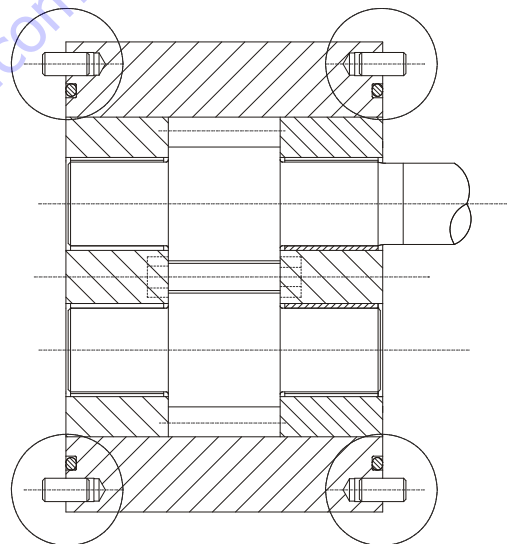
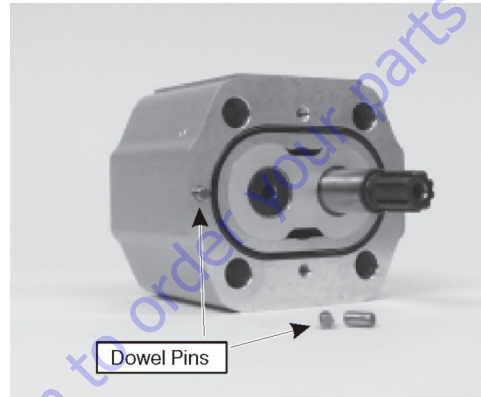

**13. Clean the mating surfaces.**

Remove any excess lubrication and grease from the mating surfaces of the front flange and rear cover. Ensure that these surfaces are dry and free of contamination before moving on to the next step.

Ensure the pressure seals are seated properly after this operation.

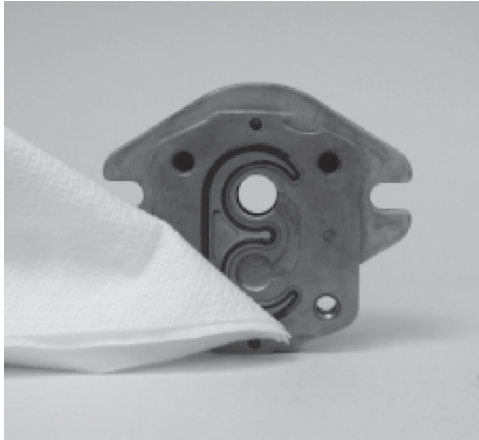

**14. Install Rear Cover.**

Mount the cover on the body. Ensure the arrow on the back is oriented properly. The arrow should be:

- In the same direction as the flow if the unit is a pump.
- Against the direction of the flow if the unit is a unidirectional motor.
- If the unit is a bidirectional motor the arrow does not appear on the cover.

Ensure that all the pressure seals stay in place during this operation.

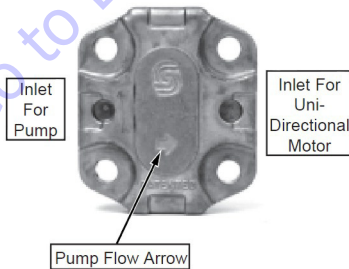

**15. Prepare pump for front flange assembly.**

Place the pump with the rear cover downwards.

Ensure that the assembly marks on the bearing block / body are properly aligned.



**16. Install the front flange.**

Install a protective sleeve over the shaft. The sleeve is used to protect the shaft seal from damage by the shaft splines / keyway during front flange assembly.

Install the flange onto the body, then remove the protective sleeve.

Ensure that the seals remain seated in their grooves during this operation.



## SECTION 5 - BASIC HYDRAULIC INFORMATION & SCHEMATICS

---

### 17. Torque sequence.

Install capscrews. While observing the torque sequence shown, pre tighten the capscrews. Then, using a torque wrench, tighten them to the proper torque.

Torque 44-54 Nm (32-40 ft.lbs.).



### 18. Install socket head capscrews.

Using a 4 mm internal hex wrench, install the socket head capscrews to the front flange and rear cover.

Torque 2.5-3.4 Nm (22-30 ft.lbs.).

If used, install new o-ring to flange pilot.





**Troubleshooting**

**Table 5-17. Troubleshooting**

<b>Low or No Flow From Gear Pump</b>		
Item	Description	Action
1. Check oil level in reservoir.	Insufficient oil to supply gear pump.	Fill reservoir to proper level.
2. Check input spline condition.	Input shaft broken or stripped.	Repair or replace gear pump.
3. Check pressure at pump inlet. Recommended inlet pressure: 0.8 to 3.0 bar absolute. 0.6 Minimum at cold start.	Clogged suction filter or inlet screen.	Replace filter or clean suction screen.
4. Check condition of gear faces and bearing blocks.	Scored bearing block and gear faces will reduce pump efficiency.	Repair or replace gear pump.
5. Check bushings.	Overpressure of gear pump will cause idler gear bushing to fail.	Repair or replace gear pump.
<b>Excessive Noise</b>		
Item	Description	Action
1. Check oil level in reservoir.	Excessive air will cause cavitation sound.	Fill reservoir to proper level.
2. Check inlet line for leaks.	Excessive air will cause cavitation sound.	Repair inlet line.
3. Check pressure at pump inlet.  Recommended inlet pressure: 0.8 to 3.0 bar absolute. 0.6 Minimum at cold start.	Lower than normal inlet pressure causes excessive pump noise.	Return inlet pressure to recommended levels.
<b>External Leakage</b>		
Item	Description	Action
1. Check for pinched o-rings or backup ring seal.	Pinched seal will allow leakage.	Replace pinched seal.
2. Check pressure seals.	Damage to pressure seals is typically caused by reduced "stack-up" in the pump assembly. This may be due to under-torqued assembly fasteners, or more commonly is attributed to excessive wear on the bearing blocks. Reduced "stack-up" will affect seal efficiency possibly to the point of seal extrusion.	Inspect condition of bearing blocks. If they are found to be worn, repair or replace the pump.  If bearing blocks are not worn, replace pressure seals and re-torque pump assembly fasteners.

### 5.5 PRESSURE SETTING PROCEDURE

#### 1. P1 Main relief valve

This is a solenoid valve and relief valve all in one. The relief portion is pre-set and non adjustable. The cartridge is located on the "T" port face of the valve block. This cartridge is the solenoid valve located at the top on that face. To check, install a pressure gauge at port "M1". Activate lower lift up. At the end of stroke, the pressure read should be 2500 psi, +/- 150 psi. If the boom cannot be raised to full extension, remove the hose from port "#6". Plug and cap. This is non adjustable, so if the setting is not correct the valve cartridge will need replaced.

#### 2. P2 Main relief valve

This is a solenoid valve and relief valve all in one. The relief portion is pre-set and non adjustable. The cartridge is located on the tank port face of the valve block. This cartridge is the solenoid valve located just above the "T" port. To check, install a pressure gauge at port "M2". Activate telescope in, or remove the hose from port "P4". Plug and cap. The pressure read should be 3000 psi, +/- 150. This is non adjustable, so if the setting is not correct the valve cartridge will need replaced.

#### 3. Swing relief valve

The swing relief valve is adjustable and is located on the "T" port face of the valve block. The relief valve is located right next to the "T" port. To check, install a pressure gauge at port "MS". Activate swing until the turn-table is bottomed out at the stop. You can also remove the hose from port "5", plug and cap. Activate swing right. You should read 1000 psi +/-100. To increase, turn clockwise. To decrease, turn counter-clockwise.

#### 4. Steer relief valve

The steer relief valve is adjustable and is located on the "T" port face of the valve block. The steer relief valve is located right next to the swing relief valve. To check, install a pressure gauge at port "M2". Activate steer right. You should read 2500 psi +/-100. To increase, turn clockwise. To decrease, turn counter-clockwise.

#### 5. Platform level up relief valve

This relief valve is adjustable and is located on the valve manifold inside the tower upright boom. Install a pressure gauge at port "M1" of this valve. Remove the hose from port L1 located on the bottom of the valve. Plug and cap. The relief valve is located above port "T2". Activate level up. The pressure read should be 2800 psi +/-100. To increase, turn clockwise. To decrease, turn counter-clockwise. Re-hose port L1.

#### 6. Platform level down relief valve

This relief valve is adjustable and is located on the valve manifold inside the tower upright boom. Install a pressure gauge at port "M2" of this valve. The relief valve is located above port "P2". Activate level down. The pressure read should be 1400 psi +/-100. To increase, turn clockwise. To decrease, turn counter-clockwise.

### 5.6 OIL SAMPLING

See Figure 5-40., Oil Sampling Port.

This machine is equipped with an oil sampling valve to allow for verification of hydraulic oil condition.

#### Procedure

1. Function the machine for approximately 15 minutes operating all functions.
2. Switch the select switch to the ground controls and start the engine.
3. Locate the oil sampling valve on the front of the main control valve.
4. Unscrew the knurled end which is attached to the chain.
5. Place a drip pan under the spout and push in for approximately 10 seconds. This should flush out the valve.
6. Open and place the sample bottle under the spout.
7. Push in on the end of the valve and fill up the bottle.
8. Cap the bottle immediately.
9. Thread the knurled cap back onto the valve.
10. The sample is complete.

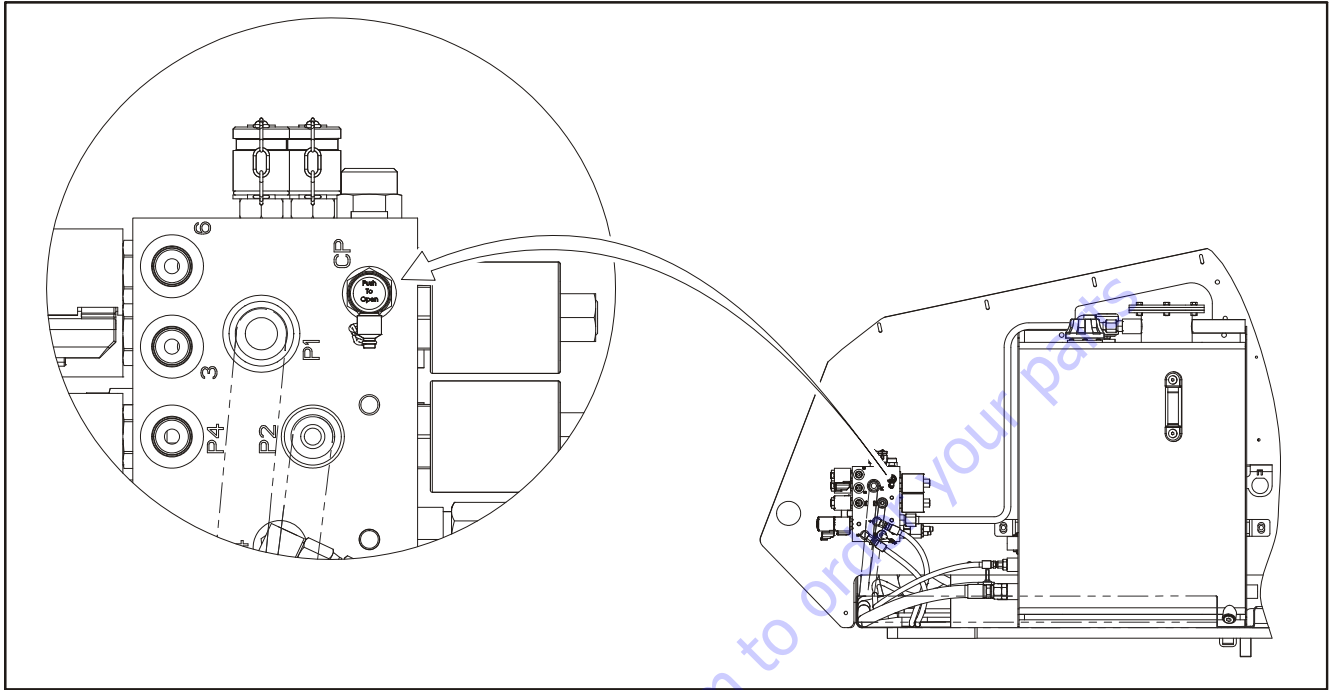

Figure 5-40. Oil Sampling Port

**SECTION 5 - BASIC HYDRAULIC INFORMATION & SCHEMATICS**



**NOTES:**

Lined area for notes, consisting of two columns of horizontal lines.

*Go to Discount-Equipment.com to order your parts*

# PARTS FINDER

**Search Website  
by Part Number**



**Search Manual  
Library For Parts  
Manual & Lookup Part  
Numbers – Purchase  
or Request Quote**

**Search Manuals**

Enter your information to search for manuals and parts.

\* Brand:

\* Model:

\* Serial:

\* Part Number:

SEARCH

**Can't Find Part or  
Manual? Request Help  
by Manufacturer,  
Model & Description**

**Parts Order Form**

Please fill in the following information:

Manufacturer:

Model:

Description:

Quantity:

Part Number:

Part Name:

Part Description:

Part Location:

Part Condition:

Part Status:

Part Color:

Part Material:

Part Weight:

Part Dimensions:

Part Price:

Part Notes:

Submit

Discount-Equipment.com is your online resource for quality parts & equipment.

Florida: **561-964-4949** Outside Florida TOLL FREE: **877-690-3101**

**Need parts?**

Click on this link: <http://www.discount-equipment.com/category/5443-parts/> and choose one of the options to help get the right parts and equipment you are looking for. Please have the machine model and serial number available in order to help us get you the correct parts. If you don't find the part on the website or on one of the online manuals, please fill out the request form and one of our experienced staff members will get back to you with a quote for the right part that your machine needs.

We sell worldwide for the brands: Genie, Terex, JLG, MultiQuip, Mikasa, Essick, Whiteman, Mayco, Toro Stone, Diamond Products, Generac Magnum, Airman, Haulotte, Barreto, Power Blanket, Nifty Lift, Atlas Copco, Chicago Pneumatic, Allmand, Miller Curber, Skyjack, Lull, Skytrak, Tsurumi, Husquvarna Target, , Stow, Wacker, Sakai, Mi-T- M, Sullair, Basic, Dynapac, MBW, Weber, Bartell, Bennar Newman, Haulotte, Ditch Runner, Menegotti, Morrison, Contec, Buddy, Crown, Edco, Wyco, Bomag, Laymor, Barreto, EZ Trench, Bil-Jax, F.S. Curtis, Gehl Pavers, Heli, Honda, ICS/PowerGrit, IHI, Partner, Imer, Clipper, MMD, Koshin, Rice, CH&E, General Equipment, ,AMida, Coleman, NAC, Gradall, Square Shooter, Kent, Stanley, Tamco, Toku, Hatz, Kohler, Robin, Wisconsin, Northrock, Oztec, Toker TK, Rol-Air, Small Line, Wanco, Yanmar

## SECTION 6. JLG CONTROL SYSTEM

6.1 JLG CONTROL SYSTEM ANALYZER KIT  
INSTRUCTIONS

## Introduction

**NOTICE**

WHEN INSTALLING A NEW POWER MODULE CONTROLLER ON THE MACHINE, IT WILL BE NECESSARY TO PROGRAM THE CONTROLLER FOR THE PROPER MACHINE CONFIGURATION, INCLUDING OPTIONS.

**NOTICE**

IT IS A GOOD PRACTICE TO AVOID PRESSURE-WASHING ELECTRICAL/ELECTRONIC COMPONENTS. SHOULD PRESSURE-WASHING BE UTILIZED TO WASH AREAS CONTAINING ELECTRICAL/ELECTRONIC COMPONENTS, JLG INDUSTRIES, INC. RECOMMENDS A MAXIMUM PRESSURE OF 750 PSI (52 BAR) AT A MINIMUM DISTANCE OF 12 INCHES (30.5 CM) AWAY FROM THESE COMPONENTS. IF ELECTRICAL/ELECTRONIC COMPONENTS ARE SPRAYED, SPRAYING MUST NOT BE DIRECT AND BE FOR BRIEF TIME PERIODS TO AVOID HEAVY SATURATION.

The JLG designed Control System is a 12 volt based motor control unit installed on the boom lift.

The JLG Control System provides simplicity in viewing and adjusting the various personality settings for smooth control of: acceleration, deceleration, creep and max.-speed for all boom, drive, and steering functions.

The upper lift, swing, and drive are controlled by individual joysticks, with steering being controlled by a rocker switch built into the top the drive joystick. To activate Drive, Lift, and Swing simply pull up on the slide lock location on the joystick and move the handle into the direction desired.

The controller will control current output, as programmed for smooth operation and maximum cycle time. Speeds for all boom functions can also be adjusted via the Personalities menu on the Analyzer.

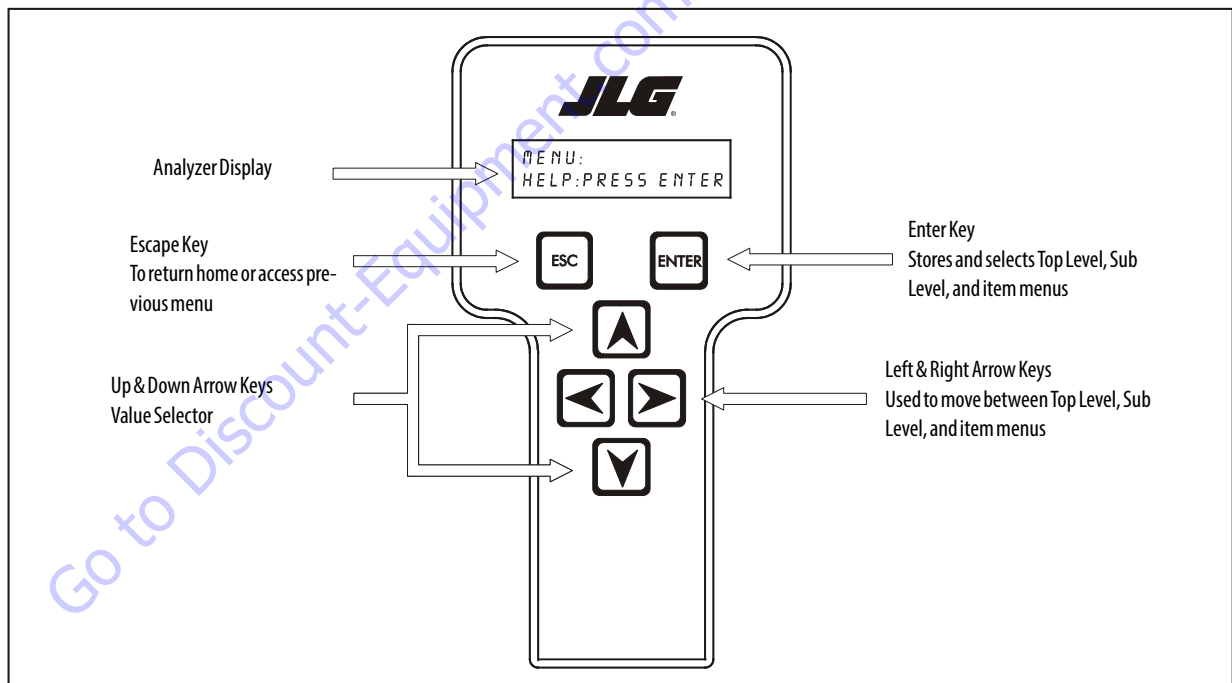

Figure 6-1. Hand Held Analyzer

The JLG Control System controller has a built in LED to indicate any faults. The system stores recent faults which may be accessed for troubleshooting. Optional equipment includes a beacon light, function cutout, and ground alarm. These options may be added later but some must be programmed into the controller when installed.

The Control System may be accessed by using a custom designed, hand held analyzer (Analyzer Kit, JLG P/N 2901443 or separately, Analyzer, JLG P/N 1600244 & Cable, JLG P/N 1600633) which will display two lines of information at a time, by scrolling through the program.

**NOTE:** Each module has a label with the JLG part number and a serial number which contains a date code.

### 6.2 ANALYZER MENU STRUCTURE

There are seven levels within the Analyzer menu structure and they are as follows;

#### 1. HELP: PRESS ENTER

This is the default menu that appears at power up of the Analyzer. This menu displays the current Help (fault) message. This is intended to quickly guide the technician in the event of a fault in the JLG Control System. This menu also displays functional interlocks. Pressing ENTER shows Logged Help which is a record of the last 25 Help (fault) messages. Editing of information in this menu is not possible.

#### 2. DIAGNOSTICS

This menu provides real-time status information about the control system as a diagnostic aid.

#### 3. SYSTEM TEST

This menu is used to activate and then interact with the Control System's self-test functionality. Starting the System Test will cause the functionality of each device to be tested. Outputs are energized to detect short or open circuit conditions and digital inputs are stimulated to simulate switching conditions. Editing of information in this menu is not possible.

#### 4. ACCESS LEVEL

This menu allows the technician to navigate between access levels; Operator Access or Service Access. To enter the Service access level, a five-digit code must be entered. Powering down returns the Analyzer to Operator Access.

#### 5. PERSONALITIES

This menu contains performance settings specific to the machine. These settings are necessary to maintain functions such as solenoid breakpoints and joystick engagement percentages and are organized in an outline format (see Figure 6-14., Analyzer Personalities Menu - Sheet 2 of 3 (Software Version P2.1)). These settings can be modified in the Service access level.

#### 6. MACHINE SETUP

This menu contains machine configuration information for the JLG Control System. Selections in this menu can change interlock functionality and cause some Personality and Machine Setup entries to be visible or hidden. These settings can be modified in the Service access level.

#### 7. CALIBRATIONS

This menu allows the operator to interact with the sensors on the machine. These settings can be modified in the Service access level.

### 6.3 USING THE HAND HELD ANALYZER

#### To Connect the JLG Control System Analyzer

1. Connect the four pin end of the cable supplied with the analyzer, to the motor controller module located in the platform box or at the power module and connect the remaining end of the cable to the analyzer.

**NOTE:** *The cable has a four pin connector at each end of the cable; the cable cannot be connected backwards.*

2. Power up the Control System by turning the lower key to the platform or ground position and pulling both emergency stop buttons on.

#### Using the Analyzer

With the machine power on and the analyzer connected properly, the analyzer will display the following:

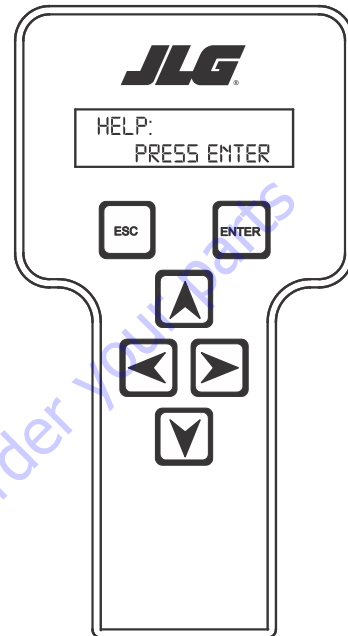

**HELP:  
PRESS ENTER**

At this point, using the **RIGHT** and **LEFT** arrow keys, you can move between the top level menu items. To select a displayed menu item, press **ENTER**. To cancel a selected menu item, press **ESC**; then you will be able to scroll using the right and left arrow keys to select a different menu item.



The top level menus are as follows:

- HELP**
- DIAGNOSTICS**
- SYSTEM TEST**
- OPERATOR ACCESS**
- PERSONALITIES**
- MACHINE SETUP**
- CALIBRATIONS (Service Access only)**

If you press **ENTER**, at the **HELP: PRESS ENTER** display, and a fault is present, the analyzer display will scroll the fault across the screen. If there was no fault detected, the display will read: **HELP: EVERYTHING OK**. If powered up at the ground station, the display will read: **GROUND OK**.

If **ENTER** is pressed again, the display moves to the following display:

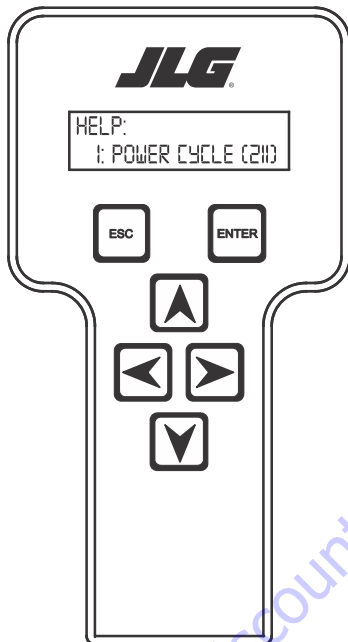

**LOG (211)  
1: POWER CYCLE**

At this point, the analyzer will display the last fault the system has seen, if any are present. You may scroll through the fault logs to view what the last 25 faults were. Use the right and left arrow keys to scroll through the fault logs. To return to the beginning, press **ESC**. two times. **POWER CYCLE (211)** indicates a power up.

When a top level menu is selected, a new set of menu items may be offered: for example:

- SYSTEM**
- DATALOG**
- VERSIONS**
- ENGINE**
- OPER CONTROLS**

Pressing **ENTER** with any of the above displayed menus, will display additional sub-menus within the selected menu. In some cases, such as **DRIVE**, the next level is the parameter or information to be changed. Refer to the flow chart for what menus are available within the top level menus. You may only view the personality settings for selected menus while in Operator Access level. Remember, you may always cancel a selected menu item by pressing the **ESC**. key.

### **Changing the Access Level of the Hand Held Analyzer**

When the analyzer is first connected, you will be in Operator Access level which enables you to only view most settings which cannot be changed until you enter a password to advance to a lower level. This ensures that a setting cannot be accidentally altered. To change the access level, the correct password must be entered. To enter the password, scroll to the **OPERATOR ACCESS** level menu. For example:

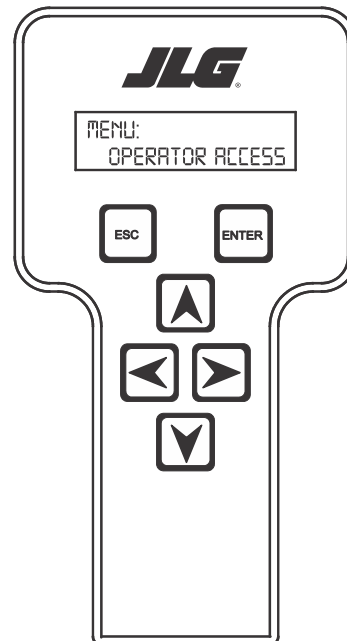

**ACCESS LEVEL:  
CODE 00000**

Press **ENTER** to select the **ACCESS LEVEL** menu.

Using the **UP** or **DOWN** arrow keys, enter the first digit of the password, 3.

Then using the **RIGHT** arrow key, position the cursor to the right one space to enter the second digit of the password.

Use the **UP** or **DOWN** arrow key to enter the second digit of the password which is 33271.

Once the correct password is displayed, press **ENTER**. The access level should display the following, if the password was entered correctly:

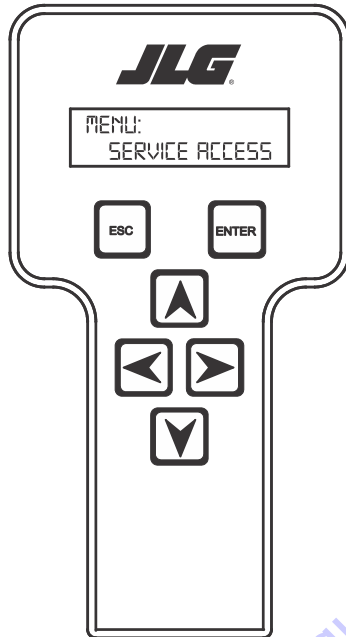

**MENU:  
SERVICE ACCESS**

Repeat the above steps if the correct access level is not displayed or you can not adjust the personality settings.

### Adjusting Parameters Using the Hand Held Analyzer

Once you have gained Service Access, and a personality item is selected, press the UP or DOWN arrow keys to adjust its value, for example:

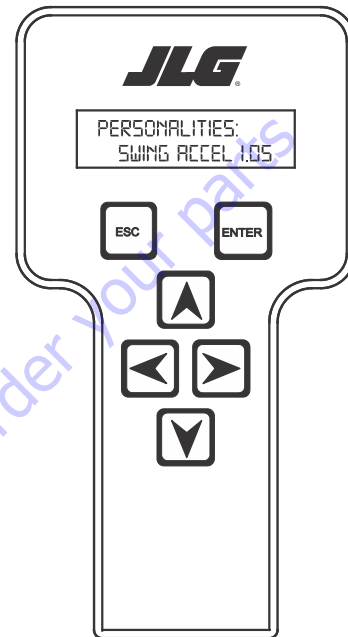

**SWING:  
ACCEL 1.0s**

There will be a minimum and maximum for the value to ensure efficient operation. The Value will not increase if the **UP** arrow is pressed when at the maximum value nor will the value decrease if the **DOWN** arrow is pressed and the value is at the minimum value for any particular personality. If the value does not change when pressing the up and down arrows, check the access level to ensure you are at Service Access.

## Machine Setup

When a machine digit item is selected, press the UP or DOWN arrow keys to adjust its value, for example:

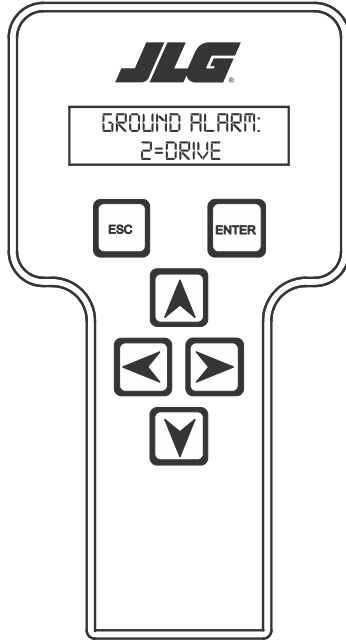

**GROUND ALARM:**  
**2 = DRIVE**

The effect of the machine digit value is displayed along with its value. The above display would be selected if the machine was equipped with a ground alarm and you wanted it to sound when driving. There are certain settings allowed to install optional features or select the machine model.

When selection the machine model to match the size of the machine, the personality settings will all default to the factory recommended setting.

**NOTE:** Refer to Table 6-6, Machine Model Adjustment for the recommended factory settings.

**NOTE:** Password 33271 will give you Service Access, which will permit you to change all machine personality settings.

There are two settings that JLG strongly recommends that you do not change. These settings are so noted below:

**DRIVE MT ELEV MAX** (Driving with engine at Max Torque and machine at maximum elevation)

**DRIVE ME ELEV MAX** (Driving with engine at Mid Engine and machine at maximum elevation)

### **⚠ WARNING**

**CHANGING THESE SETTINGS COULD ADVERSELY AFFECT THE STABILITY OF YOUR MACHINE.**

## Level Vehicle Description

### **⚠ WARNING**

**DO NOT LEVEL VEHICLE EXCEPT ON A LEVEL SURFACE.**

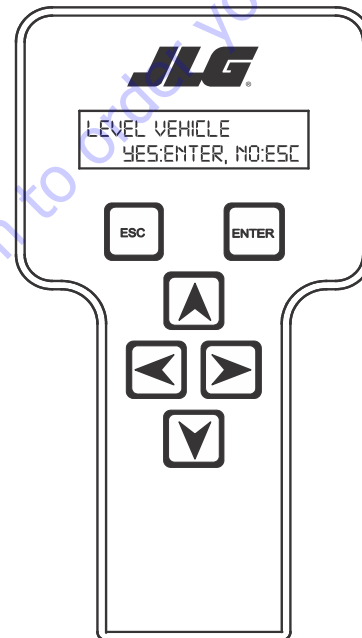

**LEVEL VEHICLE**  
**YES:ENTER, NO:ESC**

Not available in Operator Access ENTER confirms that vehicle is currently level, and zeroes the tilt sensor measurements.

Table 6-1. Analyzer Abbreviations

ABBREVIATION	MEANING
ACCEL	ACCELERATE
ACT	ACTIVE
A/D	ANALOG DIGITAL CONVERTER COUNT
AMB.	AMBIENT
ANG	ANGLE
AUX	AUXILIARY
BCS	BOOM CONTROL SYSTEM
BM	BOOM LENGTH ANGLE MODULE
BLAM	BOOM LENGTH ANGLE MODULE
BR	BROKEN
BSK	BASKET
CAL	CALIBRATION
CL	CLOSED
CM	CHASSIS MODULE
CNTL	CONTROL
CNTRL	CONTROL
C/O	CUTOUT
CONT(S)	CONTRACTOR(S)
COOR	COORDINATED
CRKPT	CRACK POINT
CRP	CREEP
CUT	CUTOUT
CYL	CYLINDER
DECEL	DECELERATE
D	DOWN
DN	DOWN
DWN	DOWN
DEG.	DEGREE
DOS	DRIVE ORIENTATION SYSTEM
DRV	DRIVE
E	ERROR
E&T	ELEVATED & TILTED
ELEV	ELEVATION
ENG	ENGINE
EXT	EXTEND
F	FRONT
FL	FLOW
FNT	FRONT
FOR	FORWARD
FWD	FORWARD
FSW	FOOT SWITCH
FUNC	FUNCTION
G	GROUND

Table 6-1. Analyzer Abbreviations

ABBREVIATION	MEANING
GND	GROUND
GRN	GREEN
GM	GROUND MODULE
H	HOURS
HW	HARDWARE
HWFS	HARDWARE FAILSAFE
I	IN or CURRENT
JOY	JOYSTICK
L	LEFT
LB	POUND
LEN	LENGTH
LIM	LIMIT
LT	LEFT
LVL	LEVEL
M	MINUTES
MIN	MINIMUM
MAX	MAXIMUM
M	MAIN
MN	MAIN
mA	MA FOR MILLIAMPERES
mA/s	MILLIAMPERES PER SECOND
NO	NORMALLY OPEN or NO
NC	NORMALLY CLOSED
O	OUT
O/C	OPEN CIRCUIT
OP	OPEN
O/R	OVERRIDE or OUTRIGGER
O//R	OVERRIDE
OSC	OSCILLATING
OVRD	OVERRIDE
P	PLATFORM
P	PRESSURE
PCV	PROPORTIONAL CONTROL VALVE
PLAT	PLATFORM
PLT	PLATFORM
PM	PLATFORM MODULE
POT	POTENTIOMETER
PRES	PRESSURE
PRS	PRESSURE
PT	POINT
R	REAR or RIGHT
REV	REVERSE or REVISION
RET	RETRACT

## SECTION 6 - JLG CONTROL SYSTEM

---

**Table 6-1. Analyzer Abbreviations**

ABBREVIATION	MEANING
ROT.	ROTATE
RT	RIGHT
S/C	SHORT CIRCUIT
SEL	SELECTOR
SN	SERIAL NUMBER
SPD	SPEED
STOW	STOWED
STOWD	STOWED
SW	SWITCH or SOFTWARE
TELE	TELESCOPE
TEMP	TEMPERATURE
TORQ.	TORQUE
TRN	TRANSPORT
T/T	TURNTABLE
T	TOWER
TURNTBL	TURNTABLE
TWR	TOWER
U	UPPER or UP
V	VOLT
VER	VERSION
VLV	VALVE
WIT	WITNESS
YEL	YELLOW

Go to Discount-Equipment.com to order your parts

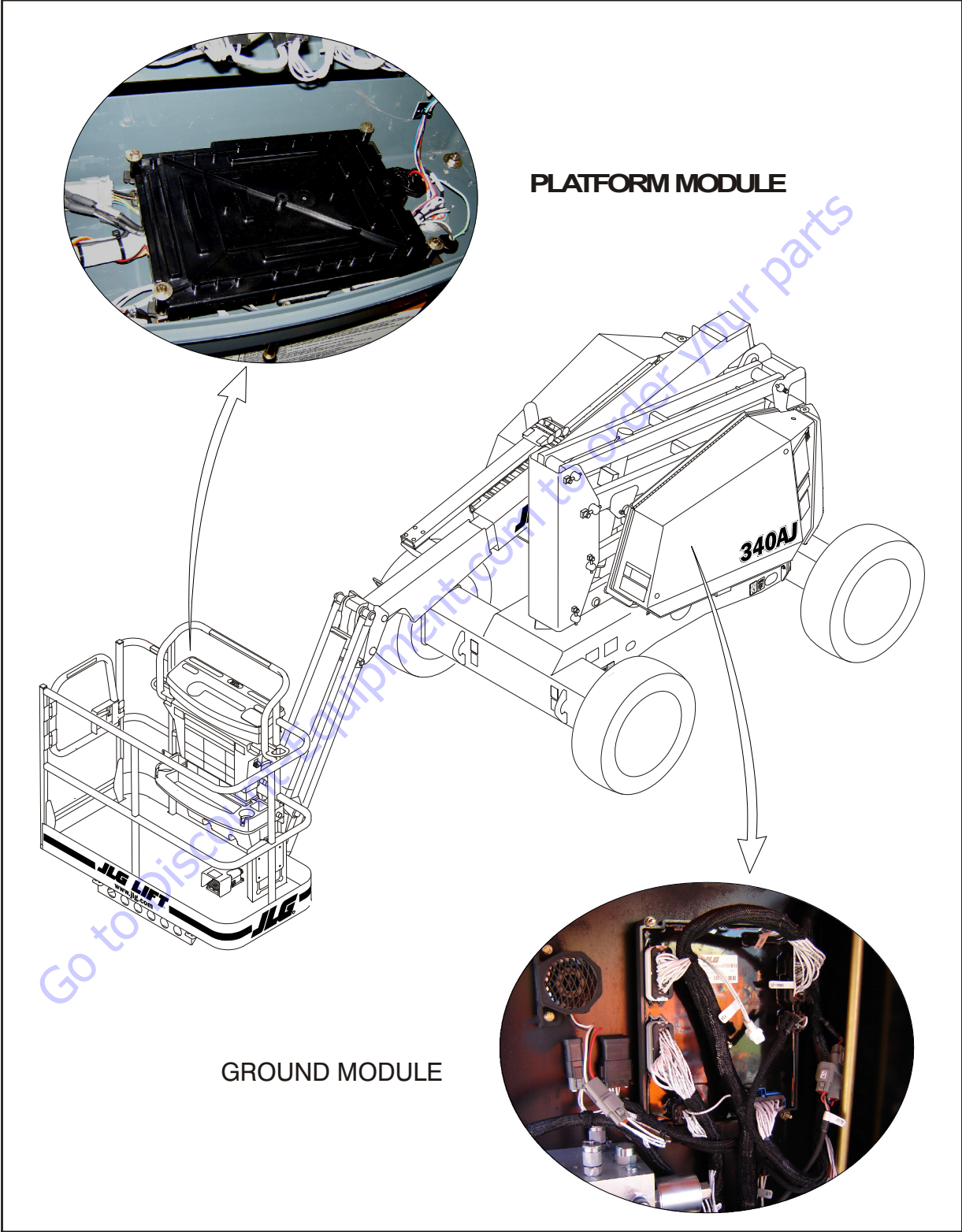

Figure 6-2. Control Module Location

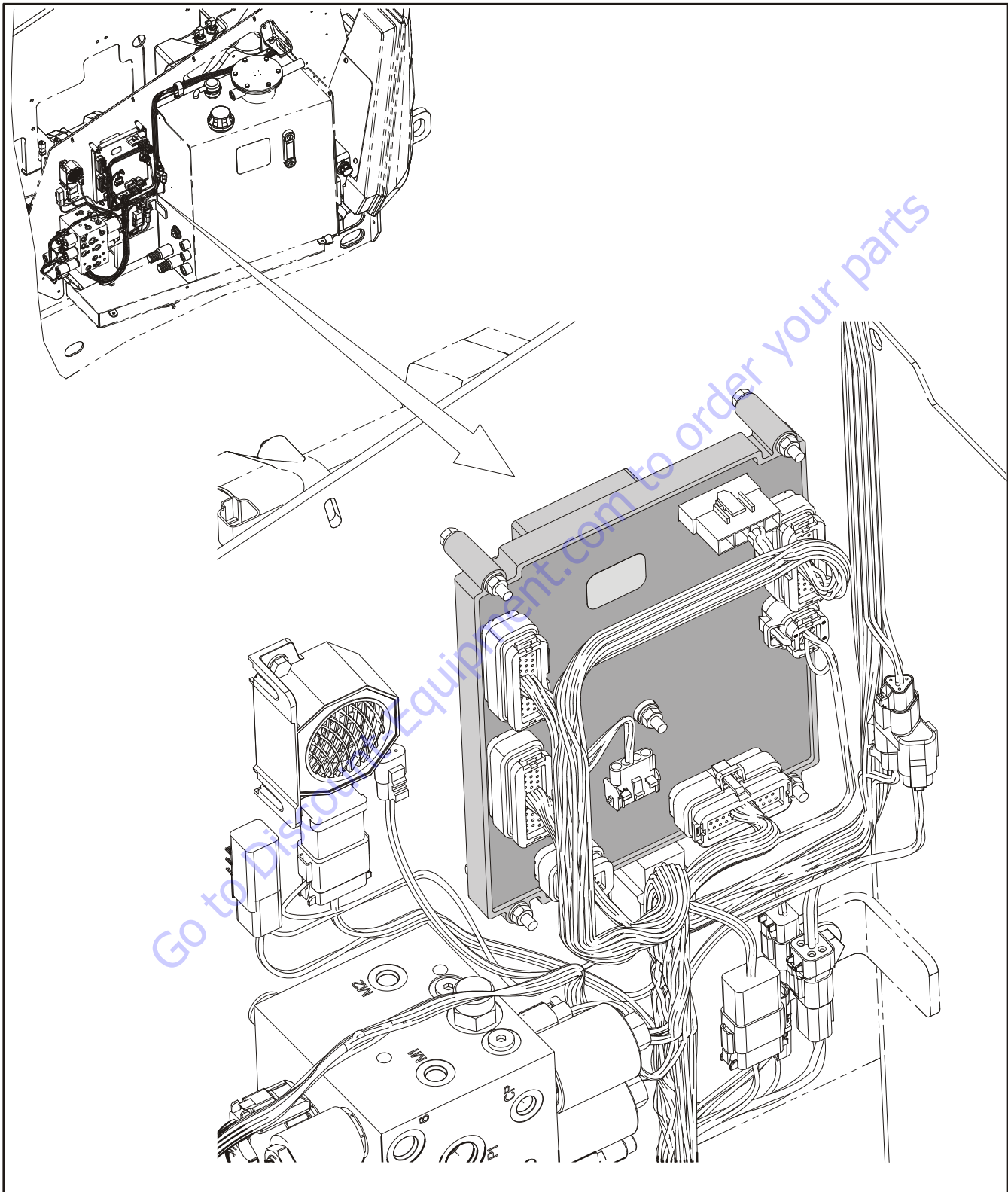
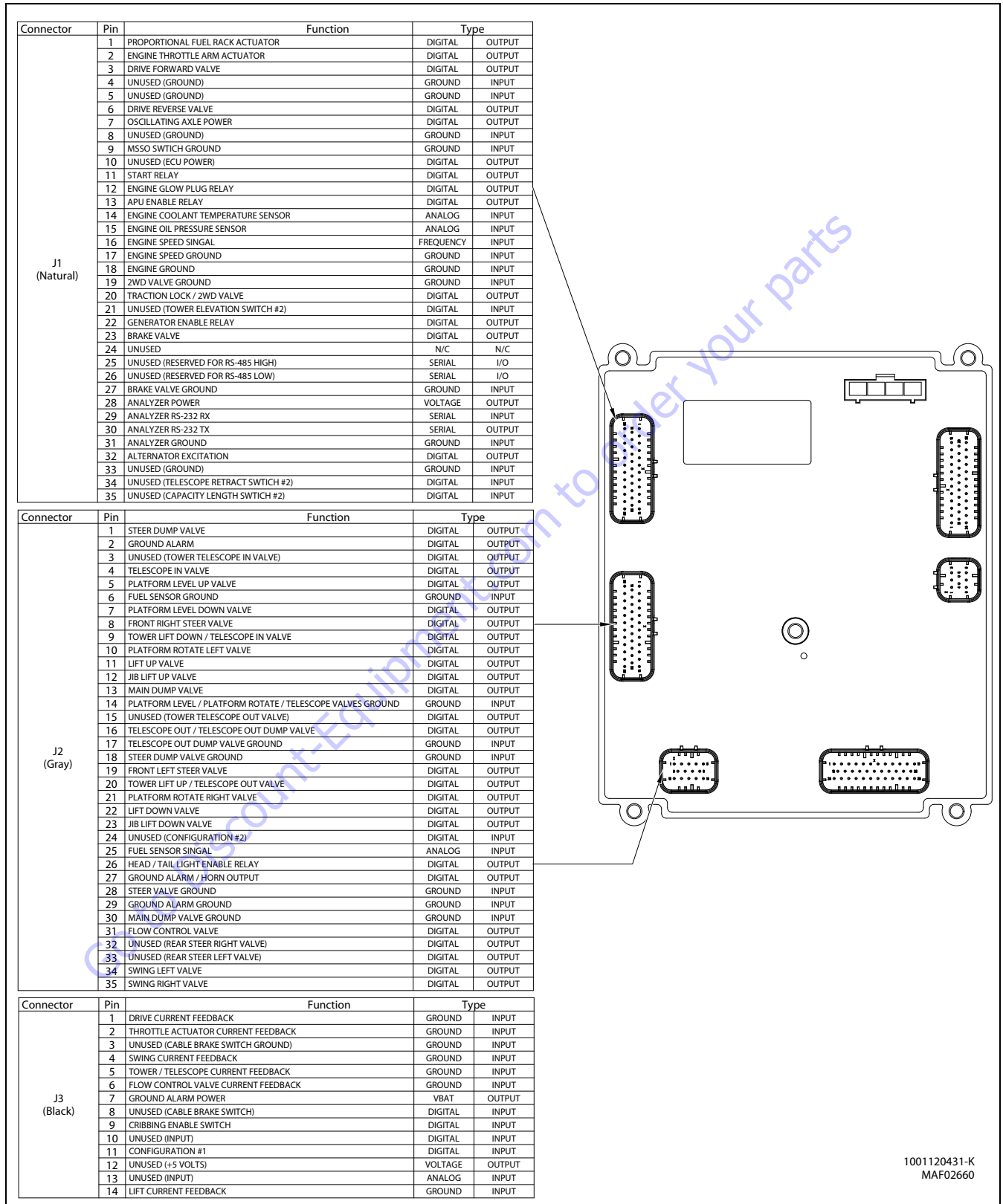

Figure 6-3. Ground Module - Sheet 1 of 4



1001120431-K  
MAF02660

Figure 6-4. Ground Module - Sheet 2 of 4



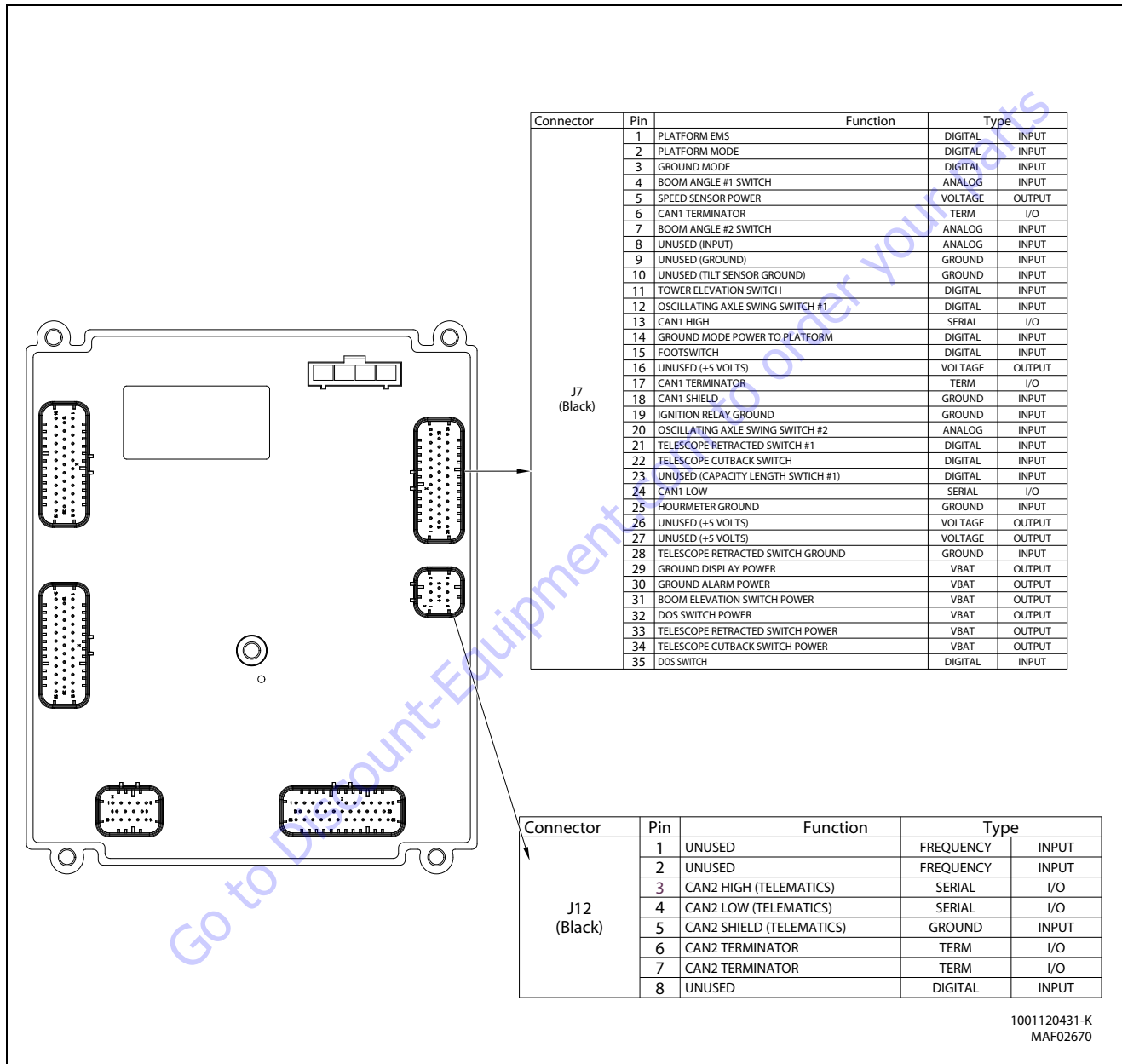

1001120431-K  
MAF02670

Figure 6-5. Ground Module - Sheet 3 of 4

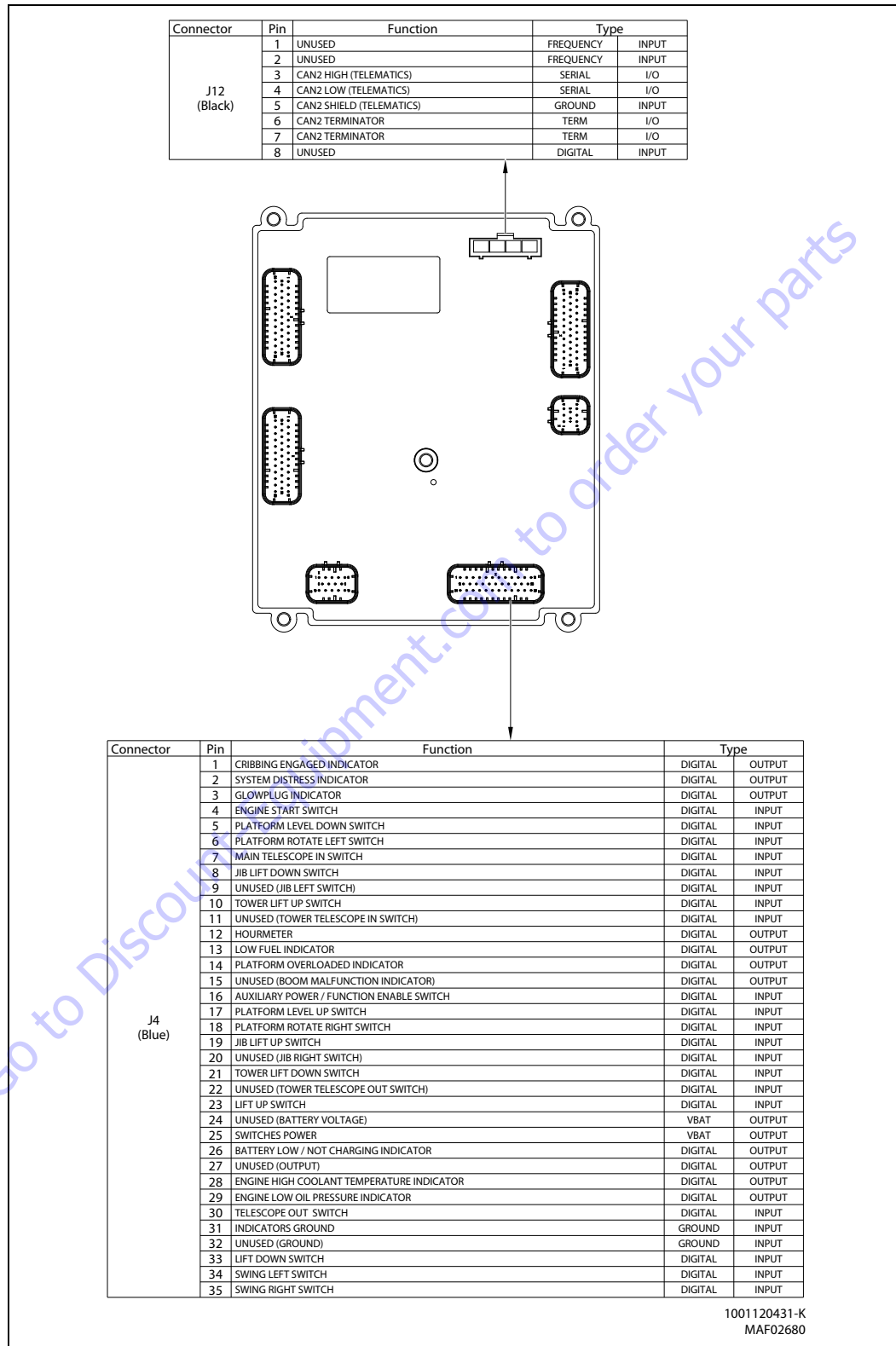

1001120431-K  
MAF02680

Figure 6-6. Ground Module - Sheet 4 of 4

# SECTION 6 - JLG CONTROL SYSTEM

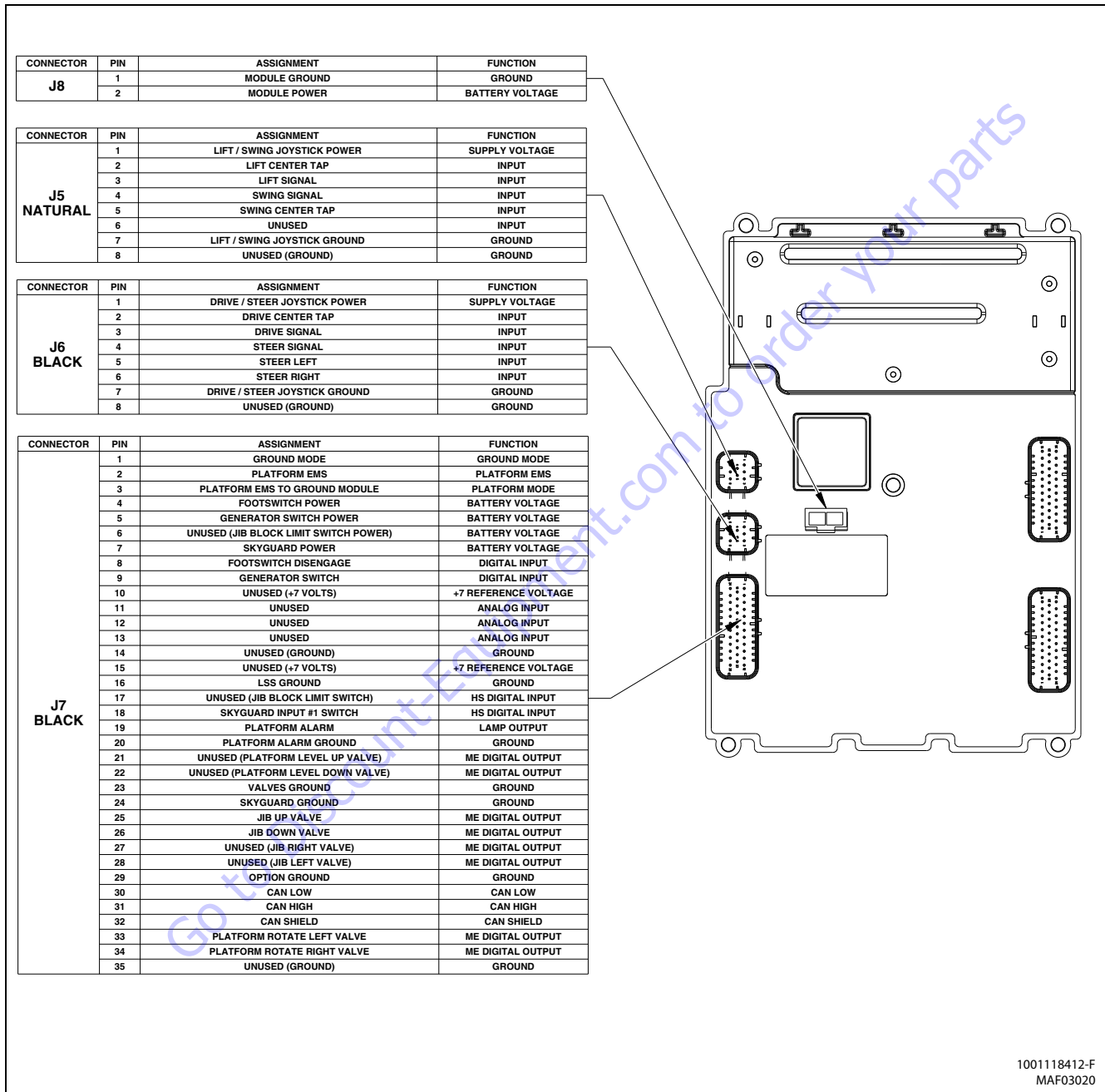

100118412-F  
MAF03020

Figure 6-7. Platform Module - Sheet 1 of 2

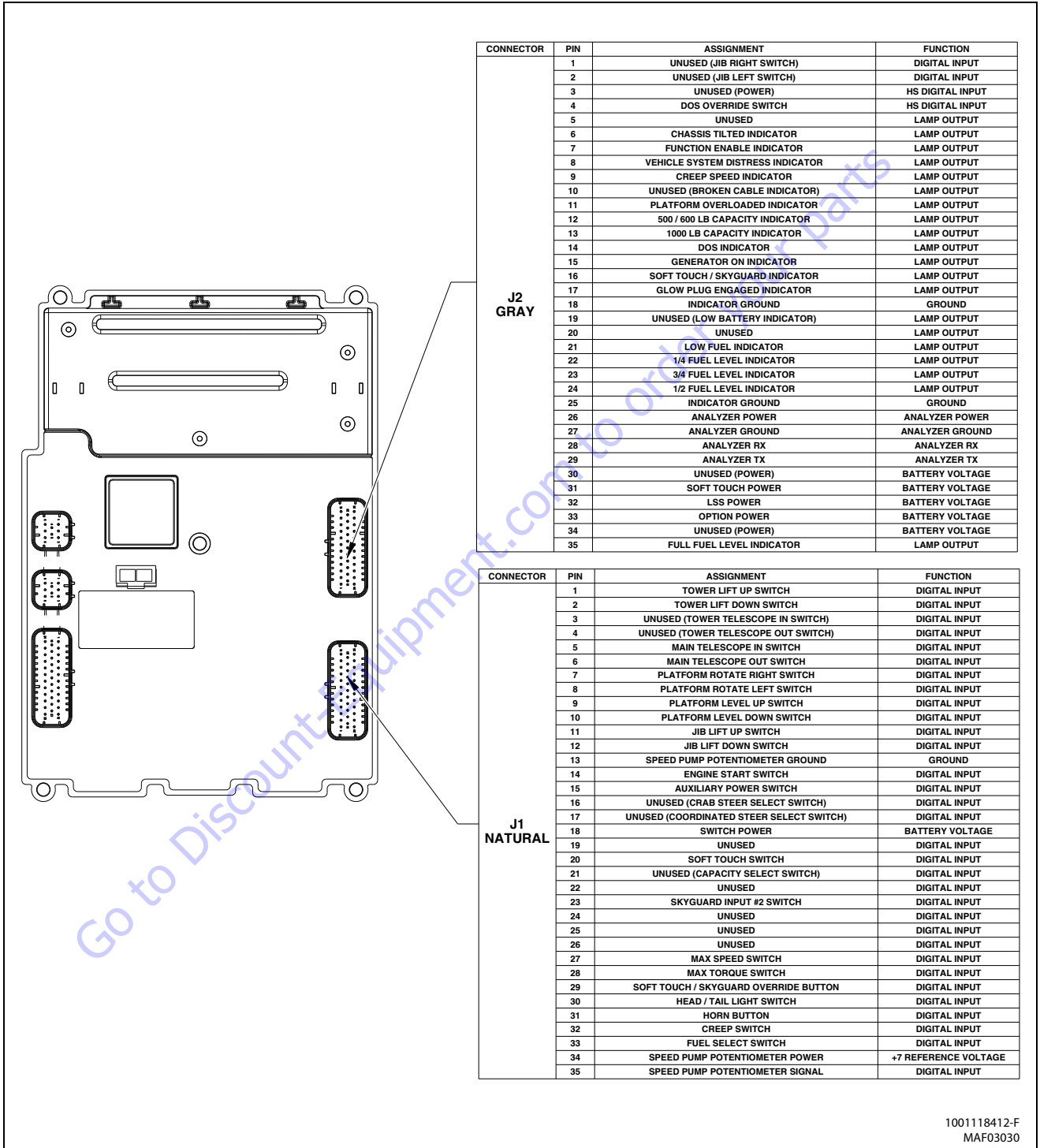

100118412-F  
MAF03030

Figure 6-8. Platform Module - Sheet 2 of 2

## 6.4 OPERATOR CONTROLS AND SWITCHES

### Ground Control Switches

The Ground Control Station has switches that allow the operator to start the engine and activate boom functions.

**Table 6-2. Ground Control Switch Inputs**

Switch	Function	Ground Module Input
Engine Start and Aux/Function Enable	Engine Start	J4-4
	Aux/Function Enable	J4-16
Swing	Left	J4-34
	Right	J4-35
Tower Lift	Up	J4-10
	Down	J4-21
Lift	Up	J4-23
	Down	J4-33
Telescope	In	J4-7
	Out	J4-30
Jib Lift	Up	J4-19
	Down	J4-8
Platform Level	Up	J4-17
	Down	J4-5
Platform Rotate	Left	J4-6
	Right	J4-18

### Platform Control Switches

The Platform Control Station has switches which allow the operator to operate boom, engine, and drive functions.

#### PROPORTIONAL JOYSTICKS

**Table 6-3. Platform Control Joystick Inputs**

Control	Function	Platform Module Input
Lift/Swing Joystick	Lift	J5-3
	Swing	J5-4
Drive/Steer Joystick	Drive	J6-3
	Steer Left	J6-5
	Steer Right	J6-6

### TOGGLE SWITCHES

**Table 6-4. Platform Control Switch Inputs**

Switch	Function	Platform Module Input
Tower Lift	Up	J1-1
	Down	J1-2
Telescope	In	J1-5
	Out	J1-6
Jib Lift	Up	J1-11
	Down	J1-12
Platform Level	Up	J1-9
	Down	J1-10
Platform Rotate	Left	J1-8
	Right	J1-7
Engine Start and Aux Descent Enable	Engine Start	J1-14
	Aux Descent Enable	J1-15
Drive Speed	Max Speed	J1-27
	Max Torque	J1-28
Drive Orientation Override	Drive Orientation Override	J2-4
Horn	Horn	J1-31

## 6.5 CONTROL SYSTEM STARTUP CHECKS

The following actions and checks are performed during system startup:

- Inhibit all hydraulic functions

- Energize all Ground and Platform Station indicators and energize the Platform Alarm.
- Perform assessments as shown in Table 6-5, System Startup Checks.

**Table 6-5. System Startup Checks**

Item Checked	Function	Condition/Action
NOTE: In this table, abbreviations STB=Short To Battery, STG=Short to Ground, and OC=Open Circuit.		
System Communications		
CAN Bus 1	Ground Module and Platform module to perform successful CAN Bus communication	Successful communication
	Verify healthy CAN Bus and presence of Platform Module	Successful communication
	If applicable, confirm presence of LSS system	Successful communication
CAN Bus 2	If applicable, confirm presence of ECU	Successful communication
Ground Station		
Digital and Functional Switch Inputs	Engine Start	Open; de-energized
	Function Enable	Open; de-energized
	Swing Left	Open; de-energized
	Swing Right	Open; de-energized
	Tower Lift Up	Open; de-energized
	Tower Lift Down	Open; de-energized
	Lift Up	Open; de-energized
	Lift Down	Open; de-energized
	Telescope In	Open; de-energized
	Telescope Out	Open; de-energized
	Jib Up	Open; de-energized
	Jib Down	Open; de-energized
	Level Up	Open; de-energized
	Level Down	Open; de-energized
Rotate Left	Open; de-energized	
Rotate Right	Open; de-energized	

**Table 6-5. System Startup Checks**

Item Checked	Function	Condition/Action
Valve and Actuator Outputs	Engine Proportional Throttle Actuator	No STB/OC No STG; energize and verify current path
	Engine High Speed Throttle Actuator	No STB/OC for relay No STG; energize to verify
	Drive Forward Valve	No STB/OC No STG; energize and verify current path
	Drive Reverse Valve	No STB/OC No STG; energize and verify current path
	Swing Left Valve	No STB/OC No STG; energize and verify current path
	Swing Right Valve	No STB/OC No STG; energize and verify current path
	Tower Lift Up Valve	No STB/OC No STG; energize and verify current path
	Tower Lift Down Valve	No STB/OC Do not check STG
	Lift Up Valve	No STB/OC No STG; energize and verify current path
	Lift Down Valve	No STB/OC Do not check STG
	Flow Control Valve	No STB/OC No STG; energize and verify current path
	Telescope In Valve	No STB/OC No STG; energize Tele In and Out simultaneously
	Telescope Out Valve	No STB/OC No STG; energize Tele In and Out simultaneously
	Level Up Valve	No STB/OC No STG; energize Level Up and Down simultaneously
Level Down Valve	No STB/OC No STG; energize Level Up and Down simultaneously	
<b>Platform Station</b>		
Digital and Functional Switch Inputs (Platform Module communicates and Ground Module verifies)	Engine Start	Open; de-energized
	Emergency Descent	Open; de-energized
	Drive Speed Select	Open or Closed, but not both Max Speed and Max Torque
	Horn	Open; de-energized
	Tower Lift Up	Open; de-energized
	Tower Lift Down	Open; de-energized
	Telescope In	Open; de-energized
	Telescope Out	Open; de-energized
	Jib Up	Open; de-energized
	Jib Down	Open; de-energized
	Level Up	Open; de-energized
	Level Down	Open; de-energized
	Rotate Left	Open; de-energized
	Rotate Right	Open; de-energized

Table 6-5. System Startup Checks

Item Checked	Function	Condition/Action
Valve and Actuator Inputs	Jib Up Valve	No STB/OC No STG; energize Jib Up
	Jib Down Valve	No STB/OC Do not check STG
	Rotate Left Valve	No STB/OC No STG; energize Rotate Left and Right simultaneously
	Rotate Right Valve	No STB/OC No STG; energize Rotate Left and Right simultaneously

Go to Discount-Equipment.com to order your parts



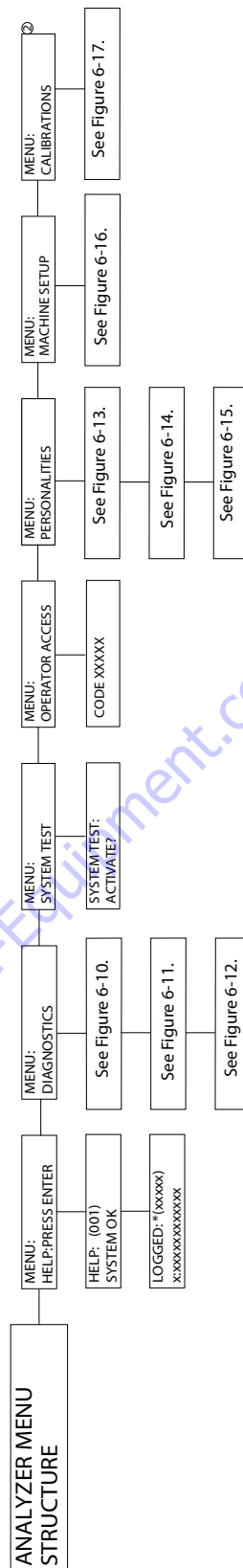

1001120432-H  
MAF02690

Figure 6-9. Analyzer Top Level Menu (Software Version P2.1)

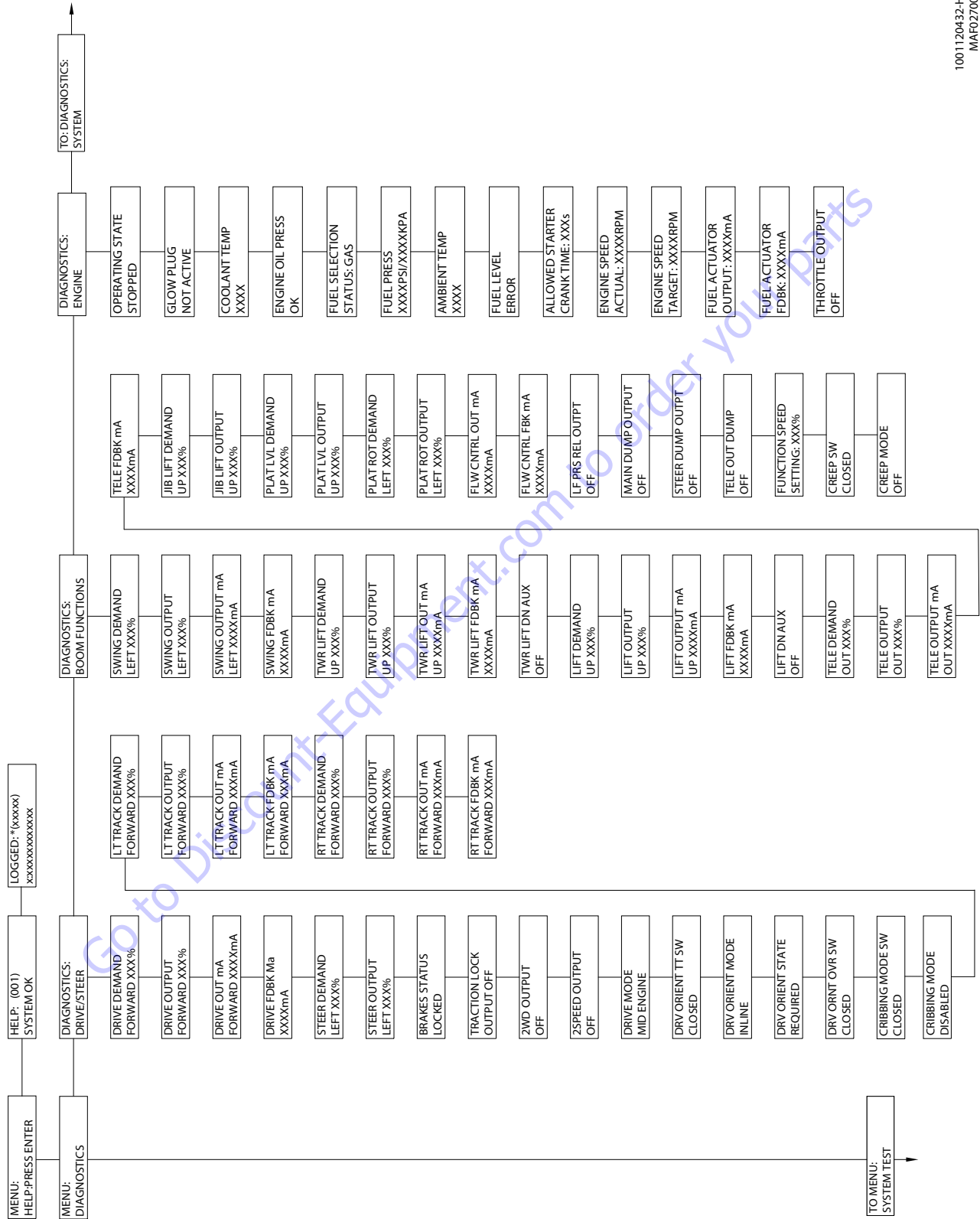
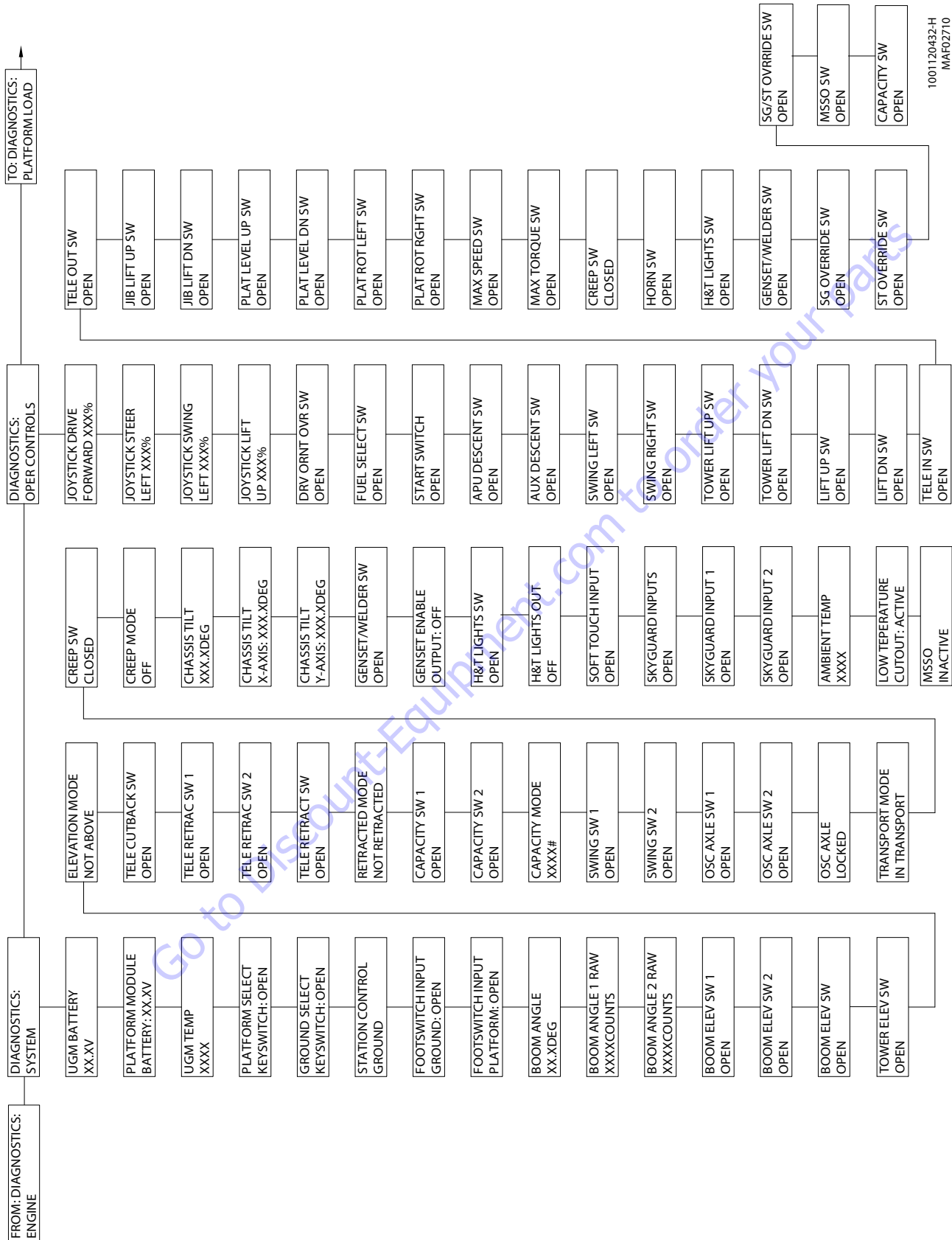

Figure 6-10. Analyzer Diagnostics Menu - Sheet 1 of 3 (Software Version P2.1)



1001120432-H  
MAF02710

Figure 6-11. Analyzer Diagnostics Menu - Sheet 2 of 3 (Software Version P2.1)

FROM: DIAGNOSTICS: OPER CONTROLS	DIAGNOSTICS: PLATFORM LOAD	DIAGNOSTICS: CAN STATISTICS	DIAGNOSTICS: CALIBRATION DATA	DIAGNOSTICS: DATALOG	DIAGNOSTICS: VERSIONS
	PLATFORM LOAD STATE: OK	CAN1 STATISTICS RV/SEC: XXXX	UGM TILT 1 X XXXX COUNTS	DATALOG CYCLES DRIVE FWD XXXX	UGM SOFTWARE XX.XX
	PLATFORM LOAD ACTUAL: XXX.XKG	CAN1 STATISTICS TX/SEC: XXXX	UGM TILT 1 Y XXXX COUNTS	DATALOG CYCLES DRIVE REV XXXX	UGM CNST DATA XX.XX
	PLATFORM LOAD GROSS: XXX.XKG	CAN1 STATISTICS BUS OFF: XXXX	UGM TILT 2 X XXXX COUNTS	DATALOG CYCLES STEER LT XXXX	UGM HARDWARE REV XX
	PLATFORM LOAD OFFSET: XXX.XKG	CAN1 STATISTICS PASSIVE: XXXXXX	UGM TILT 2 Y XXXX COUNTS	DATALOG CYCLES STEER RT XXXX	UGM S/N XXXXXX
	PLATFORM LOAD OFFSET 1: XXX.XKG	CAN1 STATISTICS MSG ERROR: XXXXX	TILT X XXX DEG	DATALOG CYCLES SWING LT XXXX	UGM P/N XX-XXXXXX-XX
	PLATFORM LOAD OFFSET 2: XXX.XKG	CAN2 STATISTICS RV/SEC: XXXX	TILT Y XXX DEG	DATALOG CYCLES SWING RT XXXX	PLATFORM MODULE SOFTWARE XX.XX
	PLATFORM LOAD ACCY: XXX.XKG	CAN2 STATISTICS TX/SEC: XXXX	DATALOG TIME DRV MS XXXH XXM	DATALOG CYCLES TOWER UP XXXX	PLATFORM MODULE HARDWARE REV XX
	PLATFORM LOAD CELL 1: XXX.XKG	CAN2 STATISTICS BUS OFF: XXXX	DATALOG TIME DRV ME XXXH XXM	DATALOG CYCLES TOWER DN XXXX	PLATFORM MODULE S/N XXXXXX
	PLATFORM LOAD CELL 2: XXX.XKG	CAN2 STATISTICS PASSIVE: XXXXXX	DATALOG TIME STEER XXXH XXM	DATALOG CYCLES LIFT UP XXXX	LSS MODULE SOFTWARE XX.XX
	PLATFORM LOAD CELL 3: XXX.XKG	CAN2 STATISTICS MSG ERROR: XXXXX	DATALOG TIME SWING XXXH XXM	DATALOG CYCLES LIFT DN XXXX	LSS MODULE HARDWARE REV XX
	PLATFORM LOAD CELL 4: XXX.XKG		DATALOG TIME TOWER XXXH XXM	DATALOG CYCLES TELE IN XXXX	TCU MODULE SOFTWARE XX.XX
	PLATFORM LOAD RAW 1: XXX.XKG		DATALOG TIME LIFT XXXH XXM	DATALOG CYCLES TELE OUT XXXX	TCU MODULE HARDWARE REV XX
	PLATFORM LOAD RAW 2: XXX.XKG		DATALOG TIME TELE XXXH XXM	DATALOG CYCLES JIB UP XXXX	TCU MODULE S/N XXXXXX
			DATALOG TIME JIB XXXH XXM	DATALOG: MAX UGM TEMP XXXX	GROUND DISPLAY SOFTWARE XX.XX
			DATALOG TIME LEVEL XXXH XXM	DATALOG: MIN UGM TEMP XXXX	ANALYZER ANALYZER XX.XX
			DATALOG TIME ROTATE XXXH XXM	DATALOG: MAX UGM VOLT XXXV	
			DATALOG TIME GEN XXXH XXM	DATALOG: MACHINE RENTAL XXXH XXM	
				DATALOG: ERASE MACHINE RENTAL?	
				CLEAR RENTAL: YES/ENTER, NO/ESC	

1001120432-H  
MAF02720

Figure 6-12. Analyzer Diagnostics Menu - Sheet 3 of 3 (Software Version P2.1)

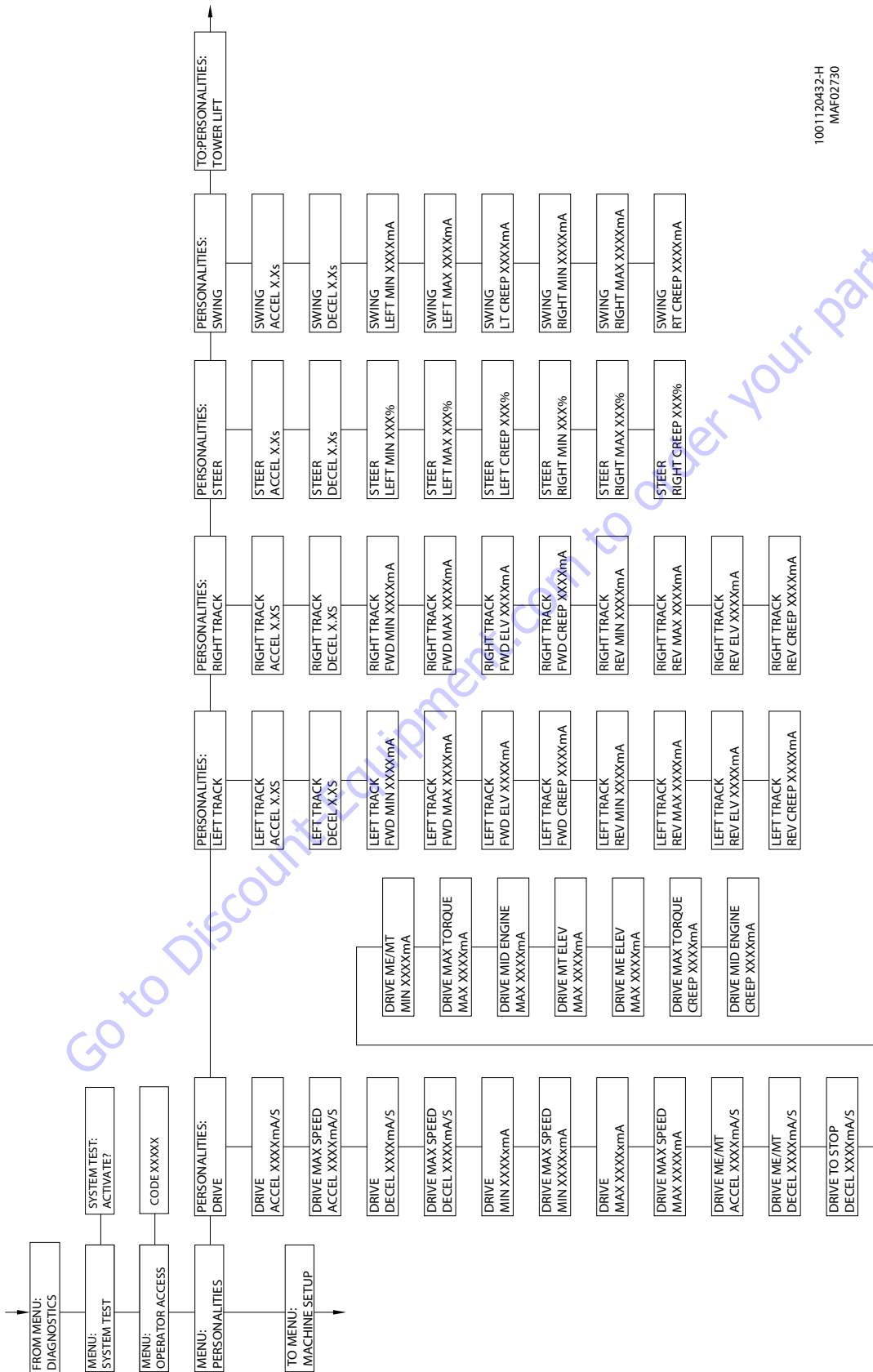

1001120432-H  
MAF02730

Figure 6-13. Analyzer Personalities Menu - Sheet 1 of 3 (Software Version P2.1)

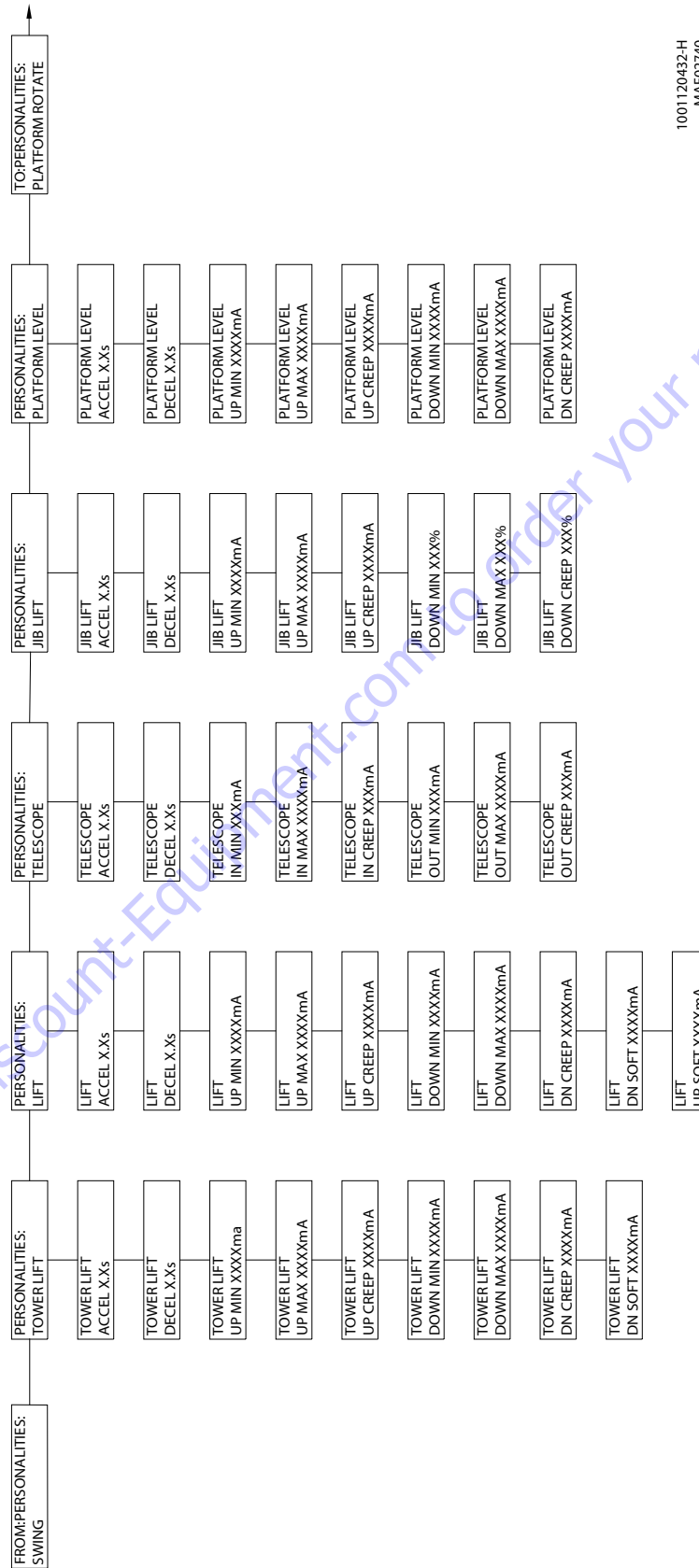

1001120432-H  
MAF02740

Figure 6-14. Analyzer Personalities Menu - Sheet 2 of 3 (Software Version P2.1)

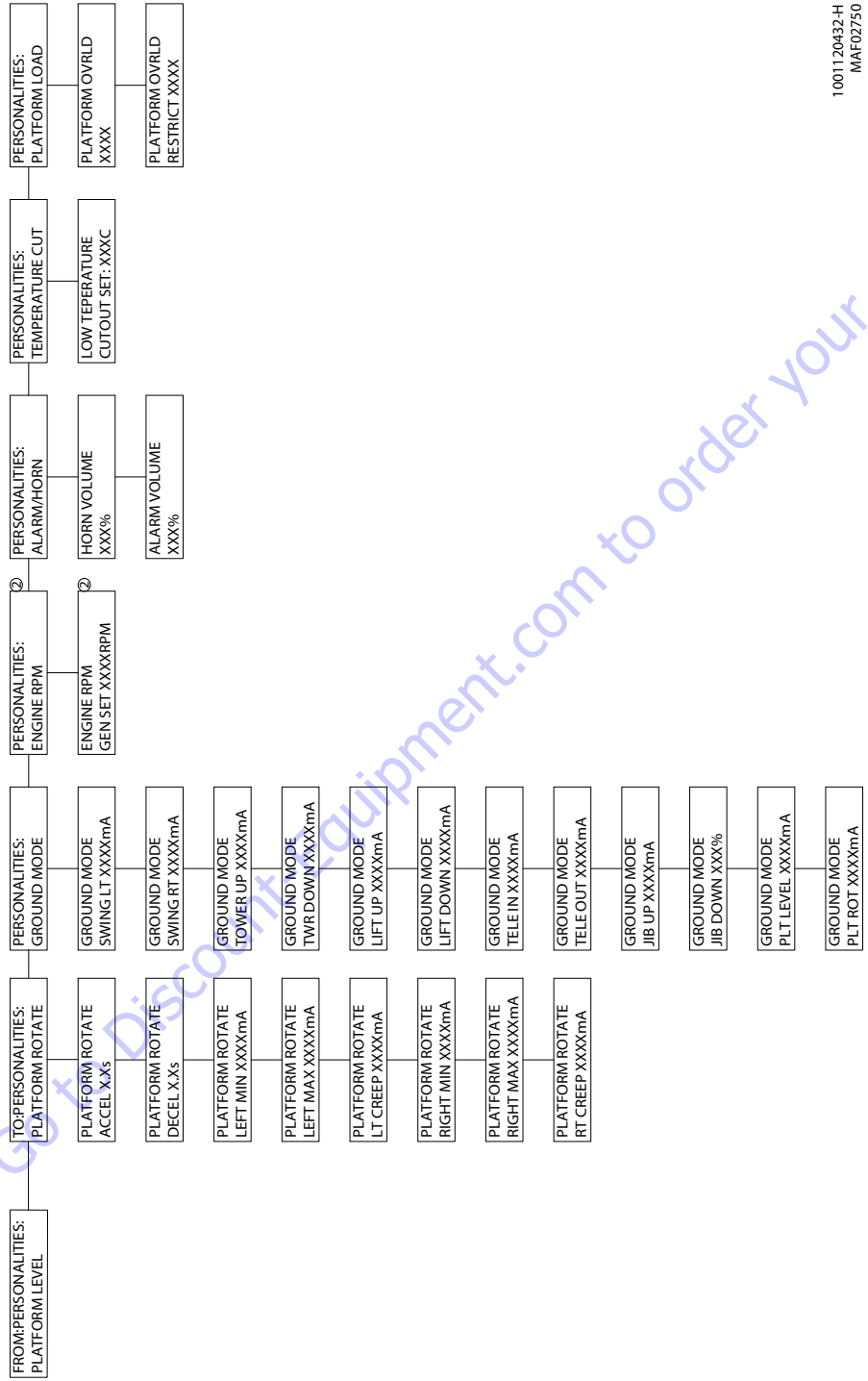

1001120432-H  
MAF02750

Figure 6-15. Analyzer Personalities Menu - Sheet 3 of 3 (Software Version P2.1)

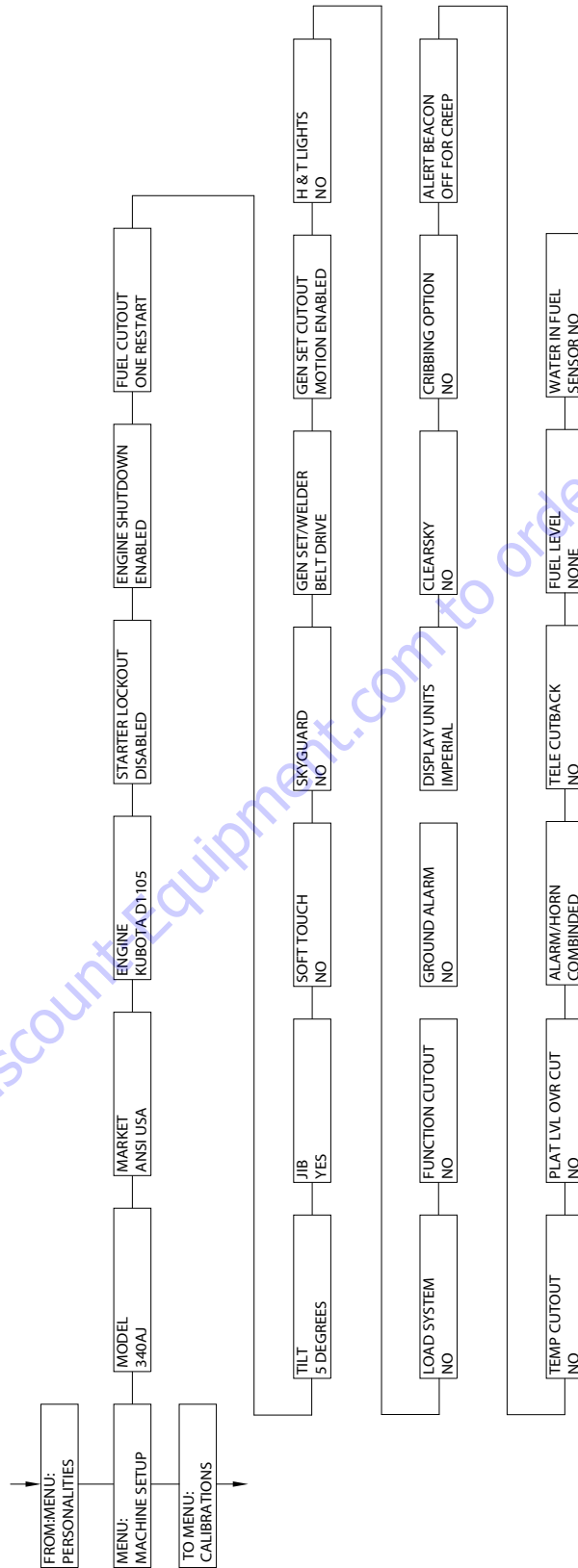

1001120432-H  
MAF02760

Figure 6-16. Analyzer Machine Setup Menu (Software Version P2.1)





1001120432-H  
MAF02770

Figure 6-17. Analyzer Calibrations Menu (Software Version P2.1)

Table 6-6. Machine Model Adjustment

Adjustment		Adjustment Ranges	Default Setting	Model Time Ranges (In Seconds)
<b>DRIVE</b>	Max Speed Accel	25 - 2000mA/sec	275mA/sec	
	Max Speed Decel	25 - 2000mA/sec	175mA/sec	
	Max Speed Min	250 - 1800mA	635mA	
	Max Speed Max	250 - 1800mA	1500mA	42-47
	Mid-Engine/Max Torque Accel	25 - 2000mA/sec	300mA/sec	
	Mid-Engine/Max Torque Decel	25 - 2000mA/sec	100mA/sec	
	Drive to Stop Decel	25-2000mA/sec	1075mA/sec	
	Drive Mid-Engine/Max Torque Min	250 - 1800mA	640mA	
	Max Torque Max	250 - 1800mA	1100mA	
	Mid-Engine Max	250 - 1800mA	1135mA	
	Max Torque Elevated	250 - 850mA	790mA	57-85
	Mid-Engine Elevated	250 - 975mA	900mA	57-85
	Max Torque Creep	250 - 750mA	725mA	
	Mid-Engine Creep	250 - 900mA	850mA	
<b>STEER</b>	Accel	0.0 - 5.0sec	0.3sec	
	Decel	0.0 - 5.0sec	0.1sec	
	Min Right	10-100%	35%	
	Max Right	10-100%	80%	
	Creep Right	10-100%	50%	
	Min Left	10-100%	35%	
	Max Left	10-100%	80%	
	Creep Left	10-100%	50%	
<b>SWING</b>	Accel	0.0 - 5.0sec	2.2sec	
	Decel	0.0 - 5.0sec	1.2sec	
	Min Left	250 - 1400mA	400mA	
	Max Left	250 - 1400mA	880mA	58-72
	Creep Left	250 - 1400mA	600mA	
	Min Right	250 - 1400mA	400mA	
	Max Right	250 - 1400mA	880mA	58-72
	Creep Right	250 - 1400mA	600mA	
<b>TOWER LIFT</b>	Accel	0.0 - 5.0sec	3.0sec	
	Decel	0.0 - 5.0sec	1.0sec	
	Min Up	250 - 1400mA	400mA	
	Max Up	250 - 1400mA	1250mA	15-21
	Creep Up	250 - 1400mA	600mA	
	Min Down	250 - 1400mA	400mA	
	Max Down	250 - 1400mA	750mA	14-20
	Creep Down	250 - 1400mA	450mA	
	Soft Down	250 - 1400mA	450mA	

Table 6-6. Machine Model Adjustment

Adjustment		Adjustment Ranges	Default Setting	Model Time Ranges (In Seconds)
<b>LIFT</b>	Accel	0.0 - 5.0sec	2.0sec	
	Decel	0.0 - 5.0sec	1.0sec	
	Min up	250 - 1400mA	400mA	
	Max Up	250 - 1400mA	1250mA	19-25
	Creep Up	250 - 1400mA	525mA	
	Min Down	250 - 1400mA	400mA	
	Max Down	250 - 1400mA	850mA	13-19
	Creep Down	250 - 1400mA	500mA	
	Soft Down	250 - 1400mA	500mA	
<b>TELESCOPE</b>	Accel	0.0 - 5.0sec	1.2sec	
	Decel	0.0 - 5.0sec	0.5sec	
	Min In	250 - 1400mA	400mA	
	Max In	250 - 1400mA	1250mA	15-21
	Creep In	250 - 1400mA	675mA	
	Min Out	250 - 1400mA	400mA	
	Max Out	250 - 1400mA	1250mA	12-18
	Creep Out	250 - 1400mA	675mA	
<b>JIB LIFT</b>	Accel	0.0 - 5.0sec	1.2sec	
	Decel	0.0 - 5.0sec	0.5sec	
	Min Up	250 - 1400mA	400mA	
	Max Up	250 - 1400mA	1075mA	25-32
	Creep Up	250 - 1400mA	575mA	
	Min Down	10 - 70%	32%	
	Max Down	10 - 70%	53%	17-23
	Creep Down	10 - 70%	48%	
<b>PLATFORM LEVEL</b>	Accel	0.0 - 5.0sec	0.0sec	
	Decel	0.0 - 5.0sec	0.0sec	
	Min Up	250 - 1400mA	400mA	
	Max Up	250 - 1400mA	1250mA	
	Creep Up	250 - 1400mA	550mA	
	Min Down	250 - 1400mA	400mA	
	Max Down	250 - 1400mA	1250mA	
	Creep Down	250 - 1400mA	550mA	
<b>PLATFORM ROTATE</b>	Accel	0.0 - 5.0sec	0.0sec	
	Decel	0.0 - 5.0sec	0.0sec	
	Min Left	250 - 1400mA	400mA	
	Max Left	250 - 1400mA	1250mA	23-34
	Creep Left	250 - 1400mA	1250mA	
	Min Right	250 - 1400mA	400mA	
	Max Right	250 - 1400mA	1250mA	23-34
	Creep Right	250 - 1400mA	1250mA	

Table 6-6. Machine Model Adjustment

Adjustment		Adjustment Ranges	Default Setting	Model Time Ranges (In Seconds)
<b>GROUND MODE</b>	Swing	250 - 1400mA	875mA	
	Tower Up	250 - 1400mA	1245mA	
	Tower Down	250 - 1400mA	745mA	
	Lift Up	250 - 1400mA	1245mA	
	Lift Down	250 - 1400mA	845mA	
	Telescope	250 - 1400mA	1245mA	
	Jib Up	250 - 1400mA	1070mA	
	Jib Down	10 - 70%	52%	
	Platform Level	250 - 1400mA	1245mA	
	Platform Rotate	250 - 1400mA	1245mA	
<b>NOTE:</b> Personality settings can be adjusted anywhere within the adjustment range in order to achieve optimum machine performance.				

1001147535-F

## SECTION 6 - JLG CONTROL SYSTEM

**Table 6-7. Machine Configuration Programming Information (Software Version P2.1)**

Configuration Label/Digit	Number	Description	Default Number
The machine configuration must be completed before any personality settings can be changed. Changing the personality settings first and then changing the model number of the machine configuration will cause the personality settings to return to default.			
MODEL NUMBER: 1	0	Visible only on a Non-Configured UGM	1
	1	<b>340AJ</b>	
	2	18RS	
	3	24RS	
MARKET: 2*	1	<b>ANSI USA</b>	1
	2	ANSI EXPORT	
	3	CSA	
	4	CE	
	5	AUSTRALIA	
	6	JAPAN	
	7	GB	
*Certain model selections will limit market options.			
ENGINE: 3*	1	<b>KUBOTA D1105</b>	1
	2	GM DUAL FUEL: GM/PSI 0.97L Dual Fuel (Tier 3)	
	3	KUBOTA DUAL FUEL	
	4	Deutz EMR2 (Tier 4i)	
	5	Deutz EMR4 (Tier 4f)	
*Only visible under certain model selections. * Certain model selections will limit engine options. * Certain market selections will limit engine options.			
FLYWHEEL TEETH: 4*	1	<b>98 TEETH: 98 flywheel teeth.</b>	1
* This menu item is not visible			
GLOW PLUG: 5*	1	NO GLOW PLUGS: No glow plugs installed.	2
	2	<b>IN-CYLINDER: Glow plugs installed in each cylinder.</b>	
* This menu item is not visible			

Table 6-7. Machine Configuration Programming Information (Software Version P2.1)

Configuration Label/Digit	Number	Description	Default Number
STARTER LOCKOUT: 6*	1	<b>DISABLED: Automatic pre-glow time determined by ambient air temperature; engine start can be attempted at any time during pre-glow.</b>	1
	2	ENABLED: Automatic pre-glow time determined by ambient air temperature; engine start is NOT permitted until pre-glow is finished.	
* Only visible for Engine Selection = Kubota D1105, Deutz EMR2 or Deutz EMR4.			
ENGINE SHUTDOWN: 7	1	DISABLED: No engine shutdown.	2
	2	<b>ENABLED: Shutdown engine for high coolant temperature fault or low oil pressure fault.</b>	
FUEL CUTOUT: 8*	1	ONE RESTART: One restart with limited run time when near Empty.	4
	2	ENGINE STOP: No starting permitted when near Empty.	
	3	NONE	
	4	<b>RESTART: Restarts allowed with limited run time when near Empty.</b>	
* Only visible for Engine Selection = Kubota D1105, Deutz EMR2 or Deutz EMR4.			
* Only visible if Fuel Level Menu selection is not NONE.			

## SECTION 6 - JLG CONTROL SYSTEM

**Table 6-7. Machine Configuration Programing Information (Software Version P2.1)**

Configuration Label/Digit	Number	Description	Default Number
TILT: 9*	1	5 DEGREES: Reduces the maximum speed of all boom functions to creep when tilted more than 5 degrees and above elevation; also reduces drive speed to creep.	9
	2	4.5 DEGREES: Reduces the maximum speed of all boom functions to creep when tilted more than 4.5 degrees and above elevation; also reduces drive speed to creep.	
	3	4 DEGREES: Reduces the maximum speed of all boom functions to creep when tilted more than 4 degrees and above elevation; also reduces drive speed to creep.	
	4	3 DEGREES: Reduces the maximum speed of all boom functions to creep when tilted more than 3 degrees and above elevation; also reduces drive speed to creep.	
	5	5 DEGREES + CUT: Reduces the maximum speed of all boom functions to creep when tilted more than 5 degrees and above elevation; also disallows tower lift up, drive, telescope out and lift up.	
	6	4.5 DEGREES + CUT: Reduces the maximum speed of all boom functions to creep when tilted more than 4.5 degrees and above elevation; also disallows tower lift up, drive, telescope out and lift up.	
	7	4 DEGREES + CUT: Reduces the maximum speed of all boom functions to creep when tilted more than 4 degrees and above elevation; also disallows tower lift up, drive, telescope out and lift up.	
	8	3 DEGREES + CUT: Reduces the maximum speed of all boom functions to creep when tilted more than 3 degrees and above elevation; also disallows tower lift up, drive, telescope out and lift up.	
	9	<b>5 DEG + DRV CUT: Reduces the maximum speed of all boom functions to creep when tilted more than 5 degrees and above elevation; also reduces drive speed to creep when drive reversal is allowed, drive is disallowed otherwise.</b>	
	10	4.5 DEG + DRV CT: Reduces the maximum speed of all boom functions to creep when tilted more than 4.5 degrees and above elevation; also reduces drive speed to creep when drive reversal is allowed, drive is disallowed otherwise.	
	11	4 DEG + DRV CUT: Reduces the maximum speed of all boom functions to creep when tilted more than 4 degrees and above elevation; also reduces drive speed to creep when drive reversal is allowed, drive is disallowed otherwise.	
	12	3 DEG + DRV CUT: Reduces the maximum speed of all boom functions to creep when tilted more than 3 degrees and above elevation; also reduces drive speed to creep when drive reversal is allowed, drive is disallowed otherwise.	
<p>* Certain market selections will limit tilt options and alter default setting.            * Drive Reversal feature of X DEG + DRV CUT does not apply to crawlers.            Note: Any of the selections above will light the tilt lamp when a tilted condition occurs and will sound the platform alarm when the machine is also above elevation.</p>			
JIB: 10*	1	NO: No jib installed.	2
	2	<b>YES: Jib installed which has up and down movements only.</b>	
<p>* Certain model selections will limit visibility.</p>			
SOFT TOUCH: 11	1	<b>NO: No Soft Touch System installed.</b>	1
	2	YES: Soft Touch System installed.	

Table 6-7. Machine Configuration Programing Information (Software Version P2.1)

Configuration Label/Digit	Number	Description	Default Number
SKYGUARD: 12	1	NO: No SkyGuard system installed.	2
	2	YES: SkyGuard system installed.	
GEN SET/WELDER: 13	1	NO: No generator installed.	1
	2	BELT DRIVE: Belt driven setup.	
GEN SET CUTOUT: 14*	1	MOTION ENABLED: Motion enabled when generator is ON.	1
	2	MOTION CUTOUT: Motion cutout in platform mode only.	
* Only visible if Gen Set / Welder Menu selection is not NO.			
H & T LIGHTS: 15*	1	NO: No head and tail lights installed.	1
	2	YES: Head and tail lights installed.	
* Only visible under certain model selections.			
LOAD SYSTEM: 16*	1	NO: No load Sensor installed.	1
	2	WARN ONLY: Functions in creep, overload lamp lit, platform alarm beeps (5 Sec ON, 2 Sec OFF).	
	3	CUTOUT PLATFORM: All functions cutout, flash overload lit, disables telescope out & lift up, platform alarm beeps (5 Sec ON, 2 Sec OFF).	
	4	CUTOUT ALL: All functions cutout, flash overload light (500mS on, 500mS off), platform alarm beeps (5 Sec ON, 2 Sec OFF).	
	5	SPECIAL 1: Functions in creep, overload lamp lit, disables telescope out & lift up, platform alarm beeps (5 Sec ON, 2 Sec OFF).	
* Only visible under certain model selections. * Certain market selections will limit load system options or alter default settings.			
FUNCTION CUTOUT: 17*	1	NO: No drive cutout.	1
	2	BOOM CUTOUT: Boom function cutout while driving above elevation.	
	3	DRIVE CUTOUT: Drive & steer cutout above elevation.	
	4	DRIVE CUT E&T: Drive & steer cutout above elevation and tilted.	
* Only visible under certain market selections. * Certain market selections will limit function cutout options or alter default setting.			
GROUND ALARM: 18	1	NO: No ground alarm installed.	4
	2	DRIVE: Travel alarm sounds when the drive function is active.	
	3	DESCENT: Descent alarm sounds when lift down is active.	
	4	MOTION: Motion alarm sounds when any function is active.	



## SECTION 6 - JLG CONTROL SYSTEM

**Table 6-7. Machine Configuration Programing Information (Software Version P2.1)**

Configuration Label/Digit	Number	Description	Default Number
DRIVE TYPE: 19*	1	<b>4WD: Fourwheel drive.</b>	<b>1</b>
	2	2WD: Two wheel drive.	
* Only visible under certain model selections.			
DISPLAY UNITS: 20*	1	METRIC: Celsius, Kilograms, Kilo Pascal.	<b>2</b>
	2	<b>IMPERIAL: Fahrenheit, Pounds, Pounds/in2</b>	
* Certain market selections will alter default setting.			
CLEARSKY: 21	1	<b>NO: ClearSky (telematics) options is disabled.</b>	<b>1</b>
	2	YES: ClearSky (telematics) option is enabled.	
* Only visible under certain model selections.			
CRIBBING OPTION: 22	1	<b>NO: Cribbing Option is disabled.</b>	<b>1</b>
	2	YES: Cribbing Option is enabled.	
* Only visible under certain model selections. * Only visible under certain market selections.			
ALERT BEACON: 23	1	<b>OFF FOR CREEP</b>	<b>1</b>
	2	IN CREEP 20FPM	
TEMP CUTOUT: 24*	1	<b>NO: No Low Temp Cutout System installed</b>	<b>1</b>
	2	YES: Low Temp Cutout System Installed	
* Only visible under certain market selections.			
PLAT LVL OVR CUTOUT: 25	1	<b>NO: Platform Level functions above elevation.</b>	<b>1</b>
	2	YES: Platform Level does not functions above elevation.	
ALARM/HORN: 26	1	SEPARATE: Ambient alarm installed.	<b>2</b>
	2	<b>COMBINED: Single Horn/Alarm installed.</b>	

Table 6-7. Machine Configuration Programming Information (Software Version P2.1)

Configuration Label/Digit	Number	Description	Default Number
TELE CUTBACK: 27*	1	<b>NO: No Telescope cutback option is disabled.</b>	1
	2	YES: Telescope cutback option is enabled.	
* Only visible under certain model selections.			
FUEL LEVEL: 28*	1	NONE: Fuel Level Switch/Sensor is not installed.	3
	2	SWITCH: Fuel Level Switch is installed.	
	3	<b>SENSOR: Fuel level Sensor is installed.</b>	
* Only visible under certain model selections.			
WATER IN FUEL SENSOR: 29*	1	<b>NO: Water in Fuel Sensor is not installed.</b>	1
	2	YES: Water in Fuel Sensor is installed.	
* Only visible under certain market selections.			
* Only visible for Engine Selection = Deutz EMR4.			

1001147652-G

**SECTION 6 - JLG CONTROL SYSTEM**

**Table 6-8. Machine Configuration Programming Settings (Software Version P2.1)**

340AJ	ANSI USA	ANSI Export	CSA	CE	Australia	Japan
Model Number	1	1	1	1	1	1
Market	1	2	3	4	5	6
Engine	1	1	1	1	1	1
	2	2	2	X	X	2
	X	X	X	X	X	X
	X	X	X	X	X	X
	X	X	X	X	X	X
Flywheel Teeth	1	1	1	1	1	1
Glow Plug	2	2	2	2	2	2
Starter Lockout	1	1	1	1	1	1
	2	2	2	2	2	2
Engine Shutdown	1	1	1	1	1	1
	2	2	2	2	2	2
Fuel Cutout	1	1	1	1	1	1
	2	2	2	2	2	2
	X	X	X	X	X	X
	4	4	4	4	4	4
Tilt	1	1	1	X	X	1
	X	X	X	X	X	X
	3	3	3	X	X	3
	4	4	4	4	4	4
	5	5	5	X	X	5
	X	X	X	X	X	X
	7	7	7	X	X	7
	8	8	8	8	8	8
	9	9	9	X	X	9
	X	X	X	X	X	X
	11	11	11	X	X	11
12	12	12	12	12	12	
Jib	X	X	X	X	X	X
	2	2	2	2	2	2
Soft Touch	1	1	1	1	1	1
	2	2	2	2	2	2
SkyGuard	1	1	1	1	1	1
	2	2	2	2	2	2
Gen Set / Welder	1	1	1	1	1	1
	2	2	2	2	2	2
Gen Set Cutout	1	1	1	1	1	1
	2	2	2	2	2	2

**Table 6-8. Machine Configuration Programming Settings (Software Version P2.1)**

340AJ	ANSI USA	ANSI Export	CSA	CE	Australia	Japan
Head & Taillights	1	1	1	1	1	1
	2	2	2	2	2	2
Load System	1	1	1	1	1	1
	X	2	X	X	X	2
	X	3	X	X	3	3
	X	4	X	4	X	4
	X	X	X	X	X	X
Function Cutout	1	1	1	X	1	1
	X	2	2	2	2	2
	3	3	3	X	3	3
	X	X	X	X	X	X
Ground Alarm	1	1	1	1	1	1
	2	2	2	2	2	2
	3	3	3	3	3	3
	4	4	4	4	4	4
Drive Type	X	X	X	X	X	X
	X	X	X	X	X	X
Display Units	1	1	1	1	1	1
	2	2	2	2	2	2
Clearsky	1	1	1	1	1	1
	2	2	2	2	2	2
Cribbing Option	1	X	X	X	X	X
	2	X	X	X	X	X
Alert Beacon	1	1	1	1	1	1
	2	2	2	2	2	2
Temp Cutout	1	1	1	1	1	1
	X	2	X	2	X	X
Plant LVL OVR Cut	1	1	1	1	1	1
	2	2	2	2	2	2
Alarm / Horn	1	1	1	1	1	1
	2	2	2	2	2	2
Tele Cutback	X	X	X	X	X	X
	X	X	X	X	X	X
Fuel Level	X	X	X	X	X	X
	X	X	X	X	X	X
	3	3	3	3	3	3
Water in Fuel Sensor	X	X	X	X	X	X
	X	X	X	X	X	X

**BOLD TEXT** indicates the default setting. Plain text indicates another available selection. **ITALIC TEXT** indicates the default when option is factory installed. SHADED CELLS indicate hidden menu or selection.

## 6.6 LSS SYSTEM

The JLG-designed Load Sensing System (LSS) measures platform load via a sensor mounted in the platform support structure. If the actual platform load exceeds the selected Rated Load, the following will occur:

1. The Overload Visual Warning Indicator will flash at the selected control position (platform or ground). 
2. The Platform and Ground Alarms will sound 5 seconds On, and 2 seconds Off.
3. All normal movement will be prevented from the platform control position (optional - ground control functions may be prevented).
4. Further movement is permitted by:
  - a. Removing the excess platform load until actual platform load is less than Rated Load.
  - b. Operation of the overriding emergency system (Auxiliary Power Unit).
  - c. By an authorized person at the ground control position (optional - ground control functions may be prevented).

### NOTICE

**THE LOAD SENSING SYSTEM MUST BE CALIBRATED WHEN ONE OR MORE OF THE FOLLOWING CONDITIONS OCCUR:**

- a. LSS Sensor removal or replacement
- b. Addition or removal of certain platform mounted accessories. (Refer to Calibration)
- c. Platform is removed, replaced, repaired or shows evidence of impact.



### NOTICE

**THE LOAD SENSING SYSTEM REQUIRES PERIODIC FUNCTION VERIFICATION NOT TO EXCEED 6 MONTHS FROM PREVIOUS VERIFICATION. REFER TO TESTING & EVALUATION.**

All calibration procedures are menu driven through the use of a JLG Analyzer.

## Diagnostic Menu

The Diagnostic Menu is another troubleshooting tool for the Load Sensing System. Sensor and status information is presented in real-time for the technician. Several sub-menus exist to organize the data.

To access the Diagnostic Menu, use the LEFT  and RIGHT  Arrow keys to select DIAGNOSTICS from the Top Level Menu. Press the ENTER key  to view the menu.

Press the LEFT and RIGHT Arrow keys to view the displays and select the various sub-menus. To access a sub-menu, press the ENTER key. Once in a sub-menu, press the LEFT and RIGHT Arrow keys to view the various displays (just like a Top Level

menu). To exit a sub-menu, press the ESC key .

Table 6-9, Diagnostic Menu Descriptions details the structure of the Diagnostic Menu, and describes the meaning of each piece of information presented.

**Table 6-9. Diagnostic Menu Descriptions**

Diagnosics Menu (Displayed on Analyzer 1 <sup>st</sup> Line)	Parameter (Displayed on Analyzer 2 <sup>nd</sup> Line)	Parameter Value (Displayed on Analyzer 2 <sup>nd</sup> Line)	Description
PLATFORM LOAD	STATE:	OK / OVERLOAD	LSS Status.
PLATFORM LOAD	ACTUAL:	XXX.X KG	Calibrated weight of the platform. ??? if Platform Load is Unhealthy**.
PLATFORM LOAD (service*)	GROSS:	XXX.X KG	Gross weight of the platform. ??? if both Cells are Unhealthy**.
PLATFORM LOAD (service*)	OFFSET 1:	XXX.X KG	Stored offset weight of Cell 1. ??? if LSS is not calibrated.
PLATFORM LOAD (service*)	OFFSET 2:	XXX.X KG	Stored offset weight of Cell 1. ??? if LSS is not calibrated.
PLATFORM LOAD (service*)	ACCESSORY	XXX.X KG	Stored accessory weight. ??? if LSS is not calibrated.
PLATFORM LOAD (service*)	UNRESTRICT	XXX.X KG	UGM will set Unrestricted Rated Load as defined by Machine Configuration.
PLATFORM LOAD (service*)	RESTRICT	XXX.X KG	UGM will set Restricted Rated Load as defined by Machine Configuration.
PLATFORM LOAD (service*)	RAW 1:	XXX.X KG	Gross value from Cell 1. ??? if Unhealthy**.
PLATFORM LOAD (service*)	RAW 2:	XXX.X KG	Gross value from Cell 2. ??? if Unhealthy**.

\* Indicates only visible in service view mode

\*\* Typically indicates a DTC is active

## Calibration Procedure

1. Remove everything from the platform, except permanently fixed JLG Accessories, to allow the Load Sensing System to record its' weight during calibration. This includes all tools, debris, and customer-installed devices.
2. Plug the JLG Analyzer into the Machine at the Ground Station and enter Service Access Password 33271.
3. The platform should be approximately level for calibration. Level the platform from ground control (if necessary) to within +/- 5°.
4. To access the Calibration Menu, use the LEFT and RIGHT Arrow keys to select CALIBRATION from the Top Level Menu. The screen will read:

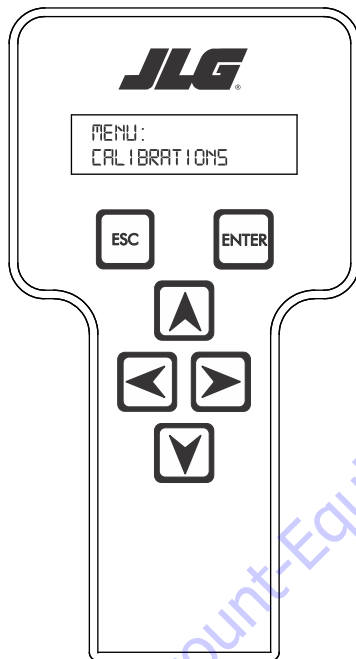

**NOTE:** The Calibration Menu is not available in OPERATOR ACCESS.

5. Press the ENTER key  to view the menu. Upon entry to the Calibration Menu, the JLG Control System will link to the Analyzer and the screen will read:

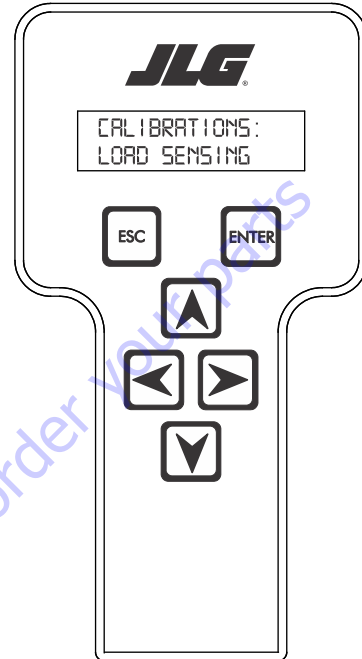

6. Press Enter . The Screen will read:

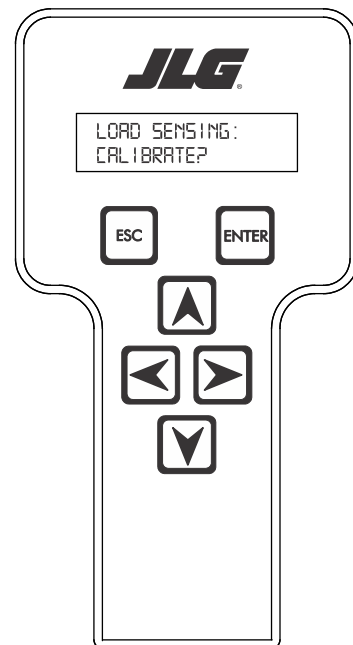

**NOTE:** Calibration will auto fail if LSS DTC's are active (443, 444, 4479, 4480, 663, 821, 822, 823, 824, 8218, 8222 -> 8238, 991, 992, 993, 994 or 99285).

Pressing the ESC key  after starting calibration and before calibration is complete will display the CAL FAILED message. This will not disturb the prior calibration information.

7. Press ENTER . The analyzer screen will read:

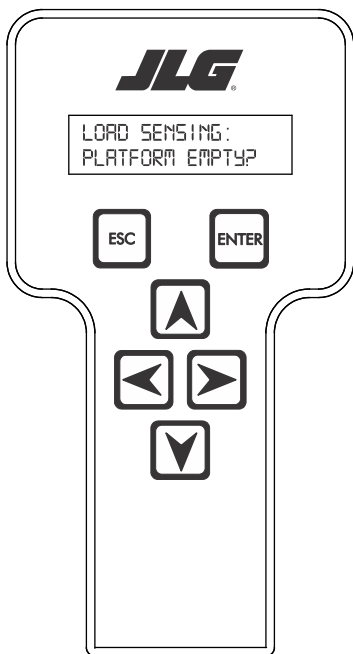

8. If the platform is empty, press ENTER . The screen will read:

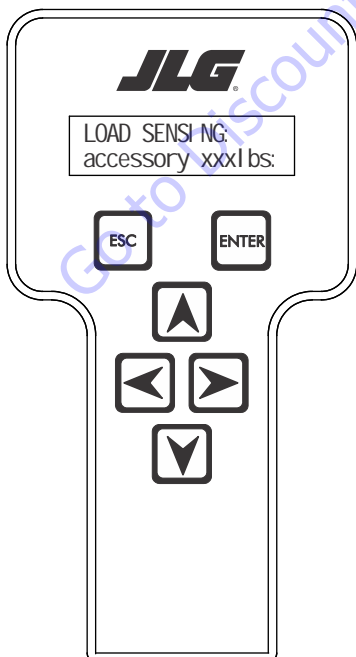

**NOTE:** Accessory weight will reset to 0 lbs. each time the machine is re-calibrated and will need to be re-entered.

**NOTE:** The Accessory weight will be temporarily stored in the Control System until calibration has been completed successfully.

Refer to Table 6-10, Accessory Weights. Use the up and down analyzer keys to enter the accessory weight(s) (in lbs). When all the accessory weights are entered, press

ENTER . The screen will read:

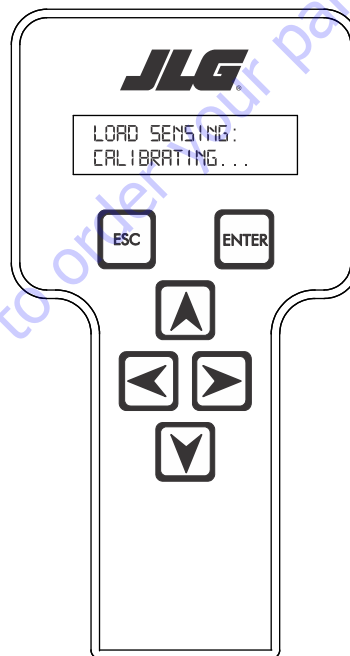

Table 6-10. Accessory Weights

Accessory	Weight
SkyWelder (stick welder)	70 lb (32 kg)
SkyWelder Prep	Prep only = 15 lb (7 kg) Full install = 70 lb (32 kg)
SkyCutter (plasma cutter)	70 lb (32 kg)
SkCutter / SkyWelder Combo	140 lb (64 kg)
Fire Extinguisher	45 lb (20 kg)
Overhead SoftTouch	80 lb (36 kg)
Work Surface	20 lb (9 kg)

**NOTE:** Not all Accessories are available on every JLG model. Some Accessory combinations are prohibited due to excessive weight and/or load restriction. If any installed JLG Accessories are labeled with weight decals but are not listed in the table above, include their weight when entering the ACC WEIGHT value.

- The control system will calculate the load cell readings and ensure it is greater than 130 lbs. (59 kg), but less than 575 lbs.(261 kg).

If the platform weight is not within the allowed range, the calibration attempt will be unsuccessful and the Analyzer will show the following:

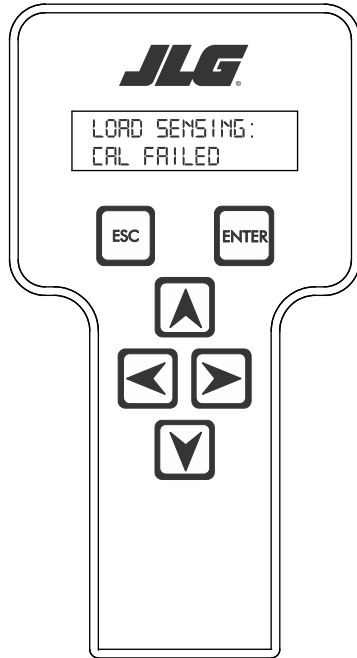

- Press ENTER . The control system will ask for installed accessories. The screen will show the following:

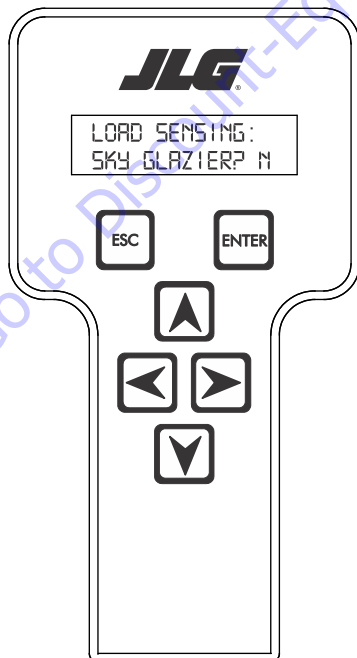

- Use the analyzer keys to select N for no or Y for yes. Press

ENTER . The screen will read:

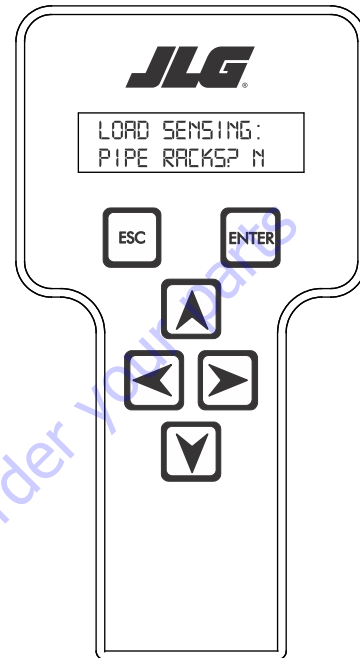



12. Use the analyzer keys to select N for no or Y for yes. Press

ENTER . The control system will default to an estimate of unrestricted capacity, which can be adjusted if necessary. Refer to Table 6-11, SkyGlazier Capacity Reductions and Table 6-12, Pipe Rack Capacity Reductions.

The screen will read:

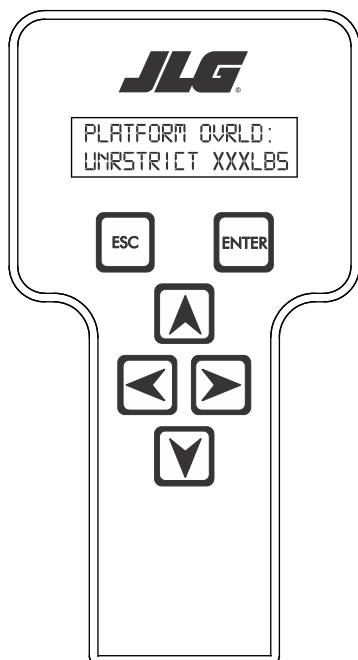

Table 6-11. SkyGlazier Capacity Reductions

Capacity	PLATFORM OVRLD	PLATFORM OVRLD RESTRICT
500 lb (227 kg)	400 lb (181 kg)	n/a
550 lb (250 kg)	400 lb (181 kg)	n/a
600 lb (272 kg)	400 lb (181 kg)	n/a
750 lb (340 kg)	n/a	590 lb (268 kg)
1000 lb (454 kg)	n/a	750 lb (340 kg)

Note: If both SkyGlazier and Pipe Racks are configured, capacity will be the lower of the two values.

Table 6-12. Pipe Rack Capacity Reductions

Capacity	PLATFORM OVRLD	PLATFORM OVRLD RESTRICT
500 lb (227 kg)	400 lb (181 kg)	n/a
550 lb (250 kg)	450 lb (204 kg)	n/a
600 lb (272 kg)	500 lb (227 kg)	n/a
750 lb (340 kg)	n/a	650 lb (295 kg)
1000 lb (454 kg)	n/a	900 lb (408 kg)

Note: If both SkyGlazier and Pipe Racks are configured, capacity will be the lower of the two values.

13. Press ENTER . The following screen will be displayed for restricted capacity, which can be adjusted if necessary. Refer to Table 6-11, SkyGlazier Capacity Reductions and Table 6-12, Pipe Rack Capacity Reductions.

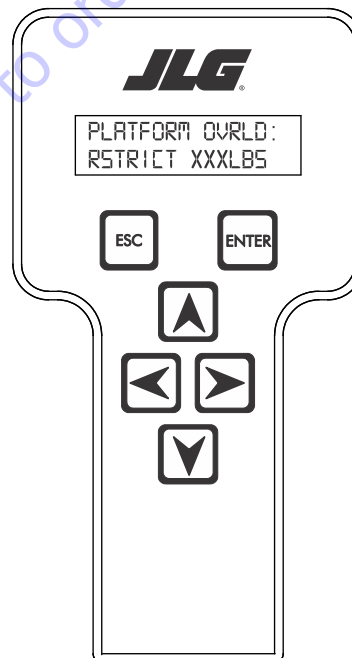

14. Press ENTER . If calibration is successful, the screen will read:

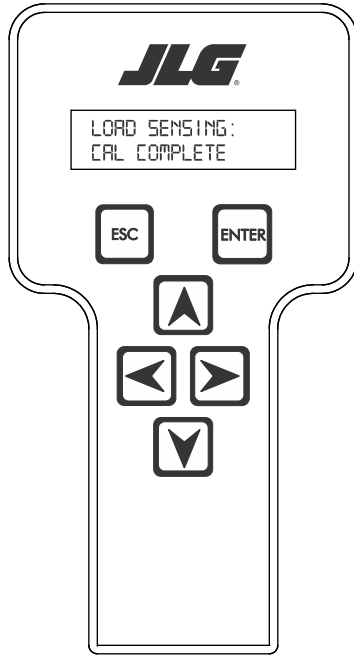

Go to Discount-Equipment.com to order your parts

### Testing & Evaluation

Refer to Troubleshooting if the Load Sensing System fails to meet these guidelines.

1. Connect the JLG Analyzer.
2. Level the Platform. The platform should be approximately level for analysis, or the guidelines below will not be applicable. Level the platform from Ground Control (if necessary) to within  $\pm 5$  degrees.
3. Observe the Empty Platform Weight. Proceed to the DIAGNOSTICS, PLTLOAD sub-menu and observe the measured platform load. All tools, debris, and customer-installed devices shall be removed during evaluation. Ideally, the PLTLOAD should be zero but can vary  $\pm 15$ lbs ( $\pm 7$ kg). Further, the reading should be stable and should not vary by more than  $\pm 2$ lbs ( $\pm 1$ kg) (unless there is heavy influence from wind or vibration).
4. Use the Technician's Weight to Evaluate. The technician should enter the platform and record the PLTLOAD reading while standing in the center of the platform.
5. Confirm Control System Warnings and Interlocks. Using the keyswitch, select Platform Mode and power-up. Start the vehicle's engine and ensure that all controls are functional and the Load Sensing System's Overload Visual and Audible Warnings are not active. Simulate an Overload by unplugging the Shear Beam Load Cell. The Overload Visual Warning should flash, and the Audible Warning (at Platform and Ground) should sound for 5 seconds On, and 2 seconds Off. With the engine running, all control should be prevented. Cycle the Platform EMS to stop the engine and then power-up again. The Overload Visual and Audible Warning should continue. Confirm that controls are responsive when using the Auxiliary Power Unit for emergency movement. Reconnect the Load Cell. The Overload Visual and Audible Warnings should cease and normal control function should return. Switch the vehicle's keyswitch to Ground Mode and repeat the above procedure. The Overload Visual Warning at the Ground Controls should flash, and the Audible Warning (at Platform and Ground) should sound for 5 seconds On, 2 seconds Off. However, the controls should remain functional when using the engine and the Auxiliary Power Unit (if the Control System's MACHINE SETUP, LOAD is set to "2=CUTOUT PLT". If set to "3=CUTOUT ALL", then Ground Controls will be prevented when using the engine as in the platform).
6. Confirm Control System Capacity Indication (optional for vehicles with Dual Capacity Ratings). For vehicles equipped with a Capacity Select switch on the Platform Console Box, it is necessary to examine an additional interface between the Load Sensing System and the Control System. Using the keyswitch, select Platform Mode and power-up. If necessary, put the boom in the transport position (completely stowed) and center the Jib Plus (if equipped). Place the Capacity Select switch in the unrestricted position and ensure that the proper indicator illuminates on the Platform Console Box. Plug the JLG Analyzer into the Analyzer connection and proceed to the DIAGNOSTICS, SYSTEM submenu. Ensure that the CAPACITY displays indicate OFF. Place the Capacity Select switch in the unrestricted position (if so equipped) and ensure that the proper indicator illuminates on the Platform Console Box (but does not flash). For vehicles with unrestricted capacity, ensure that the unrestricted CAPACITY display indicates ON but the restricted CAPACITY indicates OFF. For vehicles with restricted capacity, ensure that the unrestricted CAPACITY display indicates OFF but the restricted CAPACITY indicates ON.
7. Confirm Load Sensing System Performance with Calibrated Weights. Operate the vehicle from Ground Control and place the boom in the transport position (fully stowed) for safety. Plug the JLG Analyzer into the control system connection and proceed to the DIAGNOSTICS, PLTLOAD display. Place 500lbs (230kg) in the platform and ensure that PLTLOAD is with  $\pm 5\%$  of the actual weight. For Dual Capacity vehicles, do the same for the alternate capacity (unrestricted or restricted).

## Troubleshooting

The following tables are furnished to provide possible resolutions for common difficulties. Difficulties are classified as General, Calibration, Measurement Performance, and Host System Functionality.

**Table 6-13. LSS Troubleshooting Chart**

Difficulty	Possible Resolution
<p>Empty Platform Weight (DIAGNOSTICS, PLATFORM LOAD) is not within <math>\pm 15\text{lbs}</math> (<math>\pm 7\text{kg}</math>) of zero.</p> <p>or</p> <p>Platform Load readings (DIAGNOSTICS, PLATFORM LOAD) are unstable by more than <math>\pm 2\text{lbs}</math> (<math>\pm 1\text{kg}</math>) (without the influence of vibration or wind).</p> <p>or</p> <p>There are large variations in Platform Load (DIAGNOSTICS, PLATFORM LOAD) based on the location of the load. Tolerance to variations is 20lbs for an evaluation using the technician's weight, and <math>\pm 5\%</math> of Rated Load when using calibrated weights.</p>	<p>The LSS System is unable to properly measure the platform weight.</p> <ol style="list-style-type: none"> <li>The Load Cell is not properly plugged into the LSS Harness. It is possible poor electrical contact is made.</li> <li>Wiring leading to the Load Cell is damaged. Carefully inspect sensor wiring where it passes through cable clamps for signs of damage. Inspect wiring where damage to the channel is apparent.</li> <li>The Load Cell was not assembled properly during installation. Examine the sensor's reading using the JLG Analyzer. Proceed to the DIAGNOSTICS, CELL, LOAD displays and determine if the readings are reasonable. It is often helpful to apply slight downward pressure above the sensor and observe that its output increases (increasing force measurement; decreasing means the sensor is mounted upside-down).</li> <li>The Load Cell is contaminated by debris or moisture. Examine the sensor's reading using the JLG Analyzer. Proceed to the DIAGNOSTICS, CELL, LOAD displays and determine if the readings are reasonable and stable (not changing by more than <math>\pm 2\text{lbs}</math> (<math>\pm 1\text{kg}</math>) (without the influence of vibration or wind). Lack of measurement stability is a key indication of contamination. Unplug the connector and inspect for dirt or moisture. Look carefully into the female connector on the sensor's cordset for evidence of contamination. Debris should be brushed away with a soft bristle brush (do not introduce any cleaners as they will leave conductive residue). Moisture should be allowed to evaporate or accelerated with a heat-gun (use low heat and be carefully to not melt connector materials). Moisture intrusion into the molded portion of the connector (capillary action into the wire bundle) or the Shear Beam Load Cell itself will require replacement of the sensor.</li> <li>The Load Cell has been mechanically damaged. If the Load Cell is physically deformed or has damage to the cover it should be replaced immediately. It is also possible to have invisible mechanical damage resulting from an extreme overload (<math>&gt;6000\text{lbs}</math> [<math>&gt;2722\text{kg}</math>]).</li> </ol>
<p>The Visual and Audible Overload Warnings fail to sound when platform is loaded beyond Rated Load, or when simulated by unplugging the Load Cell. Controls remain functional at Platform and Ground Control positions.</p>	<p>The Control System is failing to regard the overload signal from the LSS System, or the signal is shorted.</p> <ol style="list-style-type: none"> <li>The Load Sensing System must be enabled within the Control System. Plug the JLG Analyzer into the Control System, enter the Access Level 1 password (33271), and examine the MACHINE SETUP, LOAD sub-menu. The selection "2=CUTOUT PLT" should be displayed (platform controls prevented during overload, ground controls remain operational). In country- or customer-specific circumstance, the selection "3=CUTOUT ALL" is used (platform and ground controls prevented during overload).</li> </ol>
<p>The Ground Audible Warning fails to sound, but the Platform Audible Warning sounds properly.</p>	<p>The Ground Alarm is missing or improperly installed. Verify that the device is mounted. Verify wiring from the Main Terminal Box and Ground Module.</p>
<p>Controls remain functional at the Ground Control position during an overload, or when simulated by unplugging the Load Cell. The Controls at the Platform Control position are prevented when using the engine, but not when using the Auxiliary Power Unit.</p>	<p>The JLG Control System is configured to prevent platform controls only in the event of overload. Alternately, the Host Control System can be configured to prevent ground and platform controls for country- or customer-specific circumstances.</p> <p>Using the JLG Analyzer, enter the Access Level 1 password (33271). Proceed to the MACHINE SETUP, LOAD sub-menu. Set this parameter to "2=CUTOUT PLT" to prevent platform controls in the event of overload. Set this parameter to "3=CUTOUT ALL" to prevent platform and ground controls in the event of overload.</p>

## 6.7 RESETTING THE MSSO SYSTEM

1. Use the following procedure to reset the MSSO system.
2. Position the Platform/Ground select switch to the desired position.
3. Plug the analyzer into the connector coming from the ground control module or from the platform console.

**NOTE:** If performing the procedure from the platform console, the Emergency Stop switch on the ground console must also be pulled out.

4. Pull out the Emergency Stop switch.
5. The analyzer screen should read:

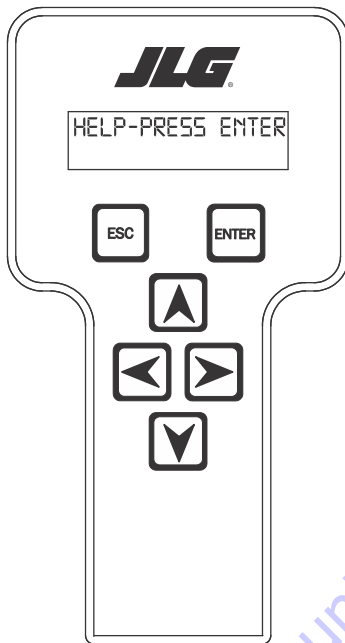

6. Use the arrow button to reach OPERATOR ACCESS. Press

Enter .

7. Enter the Access Code, 33271.

8. Use the right Arrow key to reach MENU: CALIBRATIONS.

Press Enter .

9. Use the arrow keys to reach the LOAD SENSING menu. The screen should read:

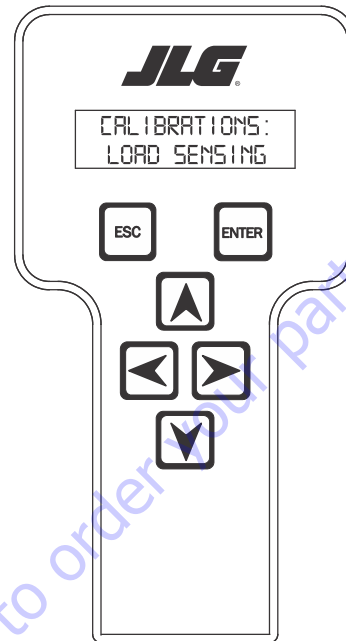



10. Press ENTER .

11. Use the Down  arrow to reach MSSO RESET.

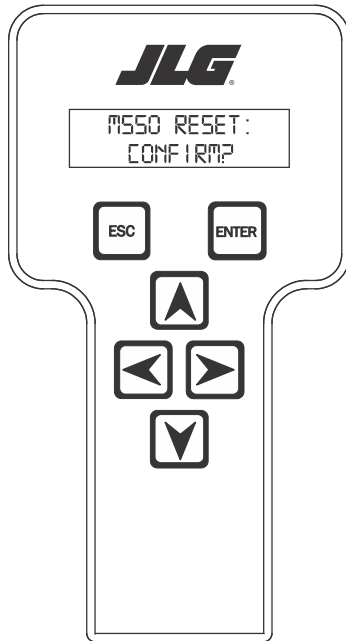
12. Press Enter . The screen will read:



13. Press Enter . The JLG Control System will reset an active 873 DTC and the MSSO System will be reset. Press Escape  to return to the CALIBRATIONS menu.

### 6.8 SYSTEM FAULT MESSAGES

The Help Message display on the JLG Analyzer provides diagnostic feedback to explain vehicle operation and interlocks. After the Analyzer is connected to the Ground Module or Platform Module, the Control System shall receive an "Initialize Analyzer" command from the Analyzer and the Control System commands the Analyzer to display the top menu item:

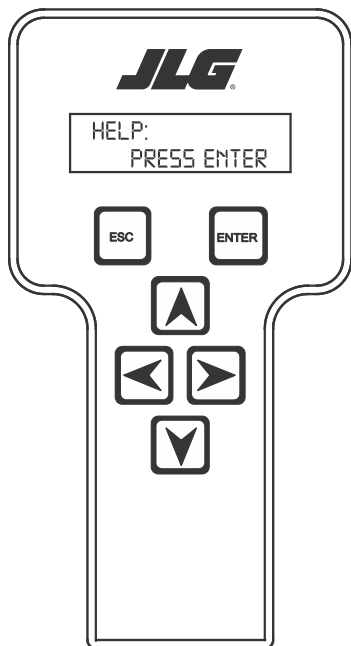

If the operator presses ENTER when in Platform Mode and no active faults are present, the Control System commands the Analyzer to display:

EVERYTHING OK

If the operator presses ENTER when in Ground Mode, display will read GROUND MODE OK.

Pressing ENTER again will cause the Analyzer to display the current Help description followed by its' Diagnostic Trouble Code (DTC). Help Messages larger than the Analyzer's display are scrolled across the screen and repeated. Using the up arrow will increase the scroll speed. If the Fault is active, an asterisk will appear beside the DTC. If the operator enters Logged Help, the Control System will show the previous 25 logged DTCs along with the Fault description on the analyzer screen.

Table 6-14, System Fault Code Listing lists the fault codes applicable for this machine and the analyzer message that accompanies the fault code. Table 6-15, Fault Code Troubleshooting Information contains evaluation, response, display, and operational requirements for each Fault condition.

Table 6-14. System Fault Code Listing

DTC	Analyzer Text
001	EVERYTHING OK
0010	RUNNING AT CUTBACK - OUT OF TRANSPORT POSITION
0011	FSW OPEN
0012	RUNNING AT CREEP - CREEP SWITCH OPEN
0013	RUNNING AT CREEP - TILTED AND ABOVE ELEVATION
0014	CHASSIS TILT SENSOR OUT OF RANGE
0030	RUNNING AT CREEP - PLATFORM STOWED
0031	FUEL LEVEL LOW - ENGINE SHUTDOWN
211	POWER CYCLE
212	KEYSWITCH FAULTY
213	FSW FAULTY
224	FUNCTION PROBLEM - STEER LEFT PERMANENTLY SELECTED
225	FUNCTION PROBLEM - STEER RIGHT PERMANENTLY SELECTED
227	STEER SWITCHES FAULTY
2211	FSW INTERLOCK TRIPPED
2212	DRIVE LOCKED - JOYSTICK MOVED BEFORE FOOTSWITCH
2213	STEER LOCKED - SELECTED BEFORE FOOTSWITCH
2216	D/S JOY. OUT OF RANGE HIGH
2217	D/S JOY. CENTER TAP BAD
2219	L/S JOY. OUT OF RANGE HIGH
2220	L/S JOY. CENTER TAP BAD
2221	LIFT/SWING LOCKED - JOYSTICK MOVED BEFORE FOOTSWITCH
2222	WAITING FOR FSW TO BE OPEN
2223	FUNCTION SWITCHES LOCKED - SELECTED BEFORE ENABLE
2224	FOOTSWITCH SELECTED BEFORE START
2247	FUNCTION PROBLEM - PLATFORM ROTATE LEFT PERMANENTLY SELECTED
2248	FUNCTION PROBLEM - PLATFORM ROTATE RIGHT PERMANENTLY SELECTED
2249	FUNCTION PROBLEM - JIB LIFT UP PERMANENTLY SELECTED
2250	FUNCTION PROBLEM - JIB LIFT DOWN PERMANENTLY SELECTED
2251	FUNCTION PROBLEM - TELESCOPE IN PERMANENTLY SELECTED
2252	FUNCTION PROBLEM - TELESCOPE OUT PERMANENTLY SELECTED
2257	FUNCTION PROBLEM - TOWER LIFT UP PERMANENTLY SELECTED
2258	FUNCTION PROBLEM - TOWER LIFT DOWN PERMANENTLY SELECTED
2262	FUNCTION PROBLEM - PLATFORM LEVEL UP PERMANENTLY SELECTED
2263	FUNCTION PROBLEM - PLATFORM LEVEL DOWN PERMANENTLY SELECTED
234	FUNCTION SWITCHES FAULTY - CHECK DIAGNOSTICS/BOOM
235	FUNCTION SWITCHES LOCKED - SELECTED BEFORE AUX POWER
236	FUNCTION SWITCHES LOCKED - SELECTED BEFORE START SWITCH
237	START SWITCH LOCKED - SELECTED BEFORE KEYSWITCH
2310	FUNCTION PROBLEM - GROUND ENABLE PERMANENTLY SELECTED
2370	FUNCTION PROBLEM - JIB LIFT UP PERMANENTLY SELECTED
2371	FUNCTION PROBLEM - JIB LIFT DOWN PERMANENTLY SELECTED
2372	FUNCTION PROBLEM - SWING LEFT PERMANENTLY SELECTED



**Table 6-14. System Fault Code Listing**

<b>DTC</b>	<b>Analyzer Text</b>
2373	FUNCTION PROBLEM - SWING RIGHT PERMANENTLY SELECTED
23104	BOOM TRANSPORT SWITCH DISAGREEMENT
23105	FUNCTION PROBLEM - TOWER LIFT UP PERMANENTLY SELECTED
23106	FUNCTION PROBLEM - TOWER LIFT DOWN PERMANENTLY SELECTED
23107	FUNCTION PROBLEM - LIFT UP PERMANENTLY SELECTED
23108	FUNCTION PROBLEM - LIFT DOWN PERMANENTLY SELECTED
23109	FUNCTION PROBLEM - TELESCOPE IN PERMANENTLY SELECTED
23110	FUNCTION PROBLEM - TELESCOPE OUT PERMANENTLY SELECTED
23111	FUNCTION PROBLEM - PLATFORM LEVEL UP PERMANENTLY SELECTED
23112	FUNCTION PROBLEM - PLATFORM LEVEL DOWN PERMANENTLY SELECTED
23113	FUNCTION PROBLEM - PLATFORM ROTATE LEFT PERMANENTLY SELECTED
23114	FUNCTION PROBLEM - PLATFORM ROTATE RIGHT PERMANENTLY SELECTED
259	MODEL CHANGED - HYDRAULICS SUSPENDED - CYCLE EMS
2513	GENERATOR MOTION CUTOUT ACTIVE
2514	BOOM PREVENTED - DRIVE SELECTED
2516	DRIVE PREVENTED - ABOVE ELEVATION
2517	DRIVE PREVENTED - TILTED & ABOVE ELEVATION
2518	DRIVE PREVENTED - BOOM SELECTED
2520	FUNCTIONS LOCKED OUT - CONSTANT DATA VERSION IMPROPER
331	BRAKE - SHORT TO BATTERY
332	BRAKE - OPEN CIRCUIT
334	LIFT UP VALVE - OPEN CIRCUIT
335	LIFT DOWN VALVE - SHORT TO BATTERY
336	LIFT DOWN VALVE - OPEN CIRCUIT
3311	GROUND ALARM - SHORT TO BATTERY
3352	LP LOCK - SHORT TO GROUND
3353	LP LOCK - OPEN CIRCUIT
3354	LP LOCK - SHORT TO BATTERY
3355	LP START ASSIST - SHORT TO GROUND
3356	LP START ASSIST - OPEN CIRCUIT
3357	LP START ASSIST - SHORT TO BATTERY
3358	MAIN DUMP VALVE - SHORT TO GROUND
3359	MAIN DUMP VALVE - OPEN CIRCUIT
3360	MAIN DUMP VALVE - SHORT TO BATTERY
3361	BRAKE - SHORT TO GROUND
3362	START SOLENOID - SHORT TO GROUND
3363	START SOLENOID - OPEN CIRCUIT
3364	START SOLENOID - SHORT TO BATTERY
3365	STEER DUMP VALVE - SHORT TO GROUND
3366	STEER DUMP VALVE - OPEN CIRCUIT
3367	STEER DUMP VALVE - SHORT TO BATTERY
3373	GEN SET/WELDER - SHORT TO GROUND
3374	GEN SET/WELDER - OPEN CIRCUIT

Table 6-14. System Fault Code Listing

DTC	Analyzer Text
3375	GEN SET/WELDER - SHORT TO BATTERY
3376	HEAD TAIL LIGHT - SHORT TO GROUND
3377	HEAD TAIL LIGHT - OPEN CIRCUIT
3378	HEAD TAIL LIGHT - SHORT TO BATTERY
3379	HOOR METER - SHORT TO GROUND
3382	PLATFORM LEVEL UP VALVE - SHORT TO GROUND
3383	PLATFORM LEVEL UP VALVE - OPEN CIRCUIT
3384	PLATFORM LEVEL UP VALVE - SHORT TO BATTERY
3388	PLATFORM LEVEL DOWN VALVE - SHORT TO GROUND
3389	PLATFORM LEVEL DOWN VALVE - OPEN CIRCUIT
3390	PLATFORM LEVEL DOWN VALVE - SHORT TO BATTERY
3394	PLATFORM ROTATE LEFT VALVE - SHORT TO GROUND
3395	PLATFORM ROTATE LEFT VALVE - OPEN CIRCUIT
3396	PLATFORM ROTATE LEFT VALVE - SHORT TO BATTERY
3397	PLATFORM ROTATE RIGHT VALVE - SHORT TO GROUND
3398	PLATFORM ROTATE RIGHT VALVE - OPEN CIRCUIT
3399	PLATFORM ROTATE RIGHT VALVE - SHORT TO BATTERY
33100	JIB LIFT UP VALVE - SHORT TO GROUND
33101	JIB LIFT UP VALVE - OPEN CIRCUIT
33102	JIB LIFT UP VALVE - SHORT TO BATTERY
33103	JIB LIFT DOWN VALVE - SHORT TO GROUND
33104	JIB LIFT DOWN VALVE - OPEN CIRCUIT
33105	JIB LIFT DOWN VALVE - SHORT TO BATTERY
33106	TOWER LIFT UP VALVE - SHORT TO GROUND
33107	TOWER LIFT UP VALVE - OPEN CIRCUIT
33109	TOWER LIFT DOWN VALVE - SHORT TO GROUND
33110	TOWER LIFT DOWN VALVE - OPEN CIRCUIT
33118	SWING RIGHT VALVE - SHORT TO GROUND
33119	SWING RIGHT VALVE - OPEN CIRCUIT
33120	TELESCOPE IN VALVE - SHORT TO BATTERY
33122	SWING LEFT VALVE - SHORT TO GROUND
33123	TELESCOPE OUT VALVE - SHORT TO BATTERY
33130	THROTTLE ACTUATOR - SHORT TO GROUND
33131	THROTTLE ACTUATOR - OPEN CIRCUIT
33132	THROTTLE ACTUATOR - SHORT TO BATTERY
33182	LIFT VALVES - SHORT TO BATTERY
33186	TELESCOPE OUT VALVE - OPEN CIRCUIT
33188	TELESCOPE OUT VALVE - SHORT TO GROUND
33189	TELESCOPE IN VALVE - OPEN CIRCUIT
33190	TELESCOPE IN VALVE - SHORT TO GROUND
33279	GLOWPLUG - OPEN CIRCUIT
33280	GLOWPLUG - SHORT TO BATTERY
33281	GLOWPLUG - SHORT TO GROUND

**Table 6-14. System Fault Code Listing**

<b>DTC</b>	<b>Analyzer Text</b>
33287	LIFT - CURRENT FEEDBACK READING TOO LOW
33295	SWING LEFT VALVE - OPEN CIRCUIT
33314	FLOW CONTROL VALVE - OPEN CIRCUIT
33315	FLOW CONTROL VALVE - SHORT TO BATTERY
33316	FLOW CONTROL VALVE - SHORT TO GROUND
33317	DRIVE FORWARD VALVE - OPEN CIRCUIT
33318	DRIVE FORWARD VALVE - SHORT TO BATTERY
33319	DRIVE FORWARD VALVE - SHORT TO GROUND
33320	DRIVE REVERSE VALVE - OPEN CIRCUIT
33322	DRIVE REVERSE VALVE - SHORT TO GROUND
33331	DRIVE - CURRENT FEEDBACK READING TOO LOW
33406	LIFT UP VALVE - SHORT TO GROUND
33410	DRIVE - CURRENT FEEDBACK READING LOST
33412	SWING VALVES - SHORT TO BATTERY
33413	TOWER LIFT - CURRENT FEEDBACK READING TOO LOW
33414	SWING - CURRENT FEEDBACK READING TOO LOW
33415	FLOW CONTROL VALVE - CURRENT FEEDBACK READING TOO LOW
33416	TOWER LIFT - CURRENT FEEDBACK READING LOST
33417	LIFT - CURRENT FEEDBACK READING LOST
33418	SWING - CURRENT FEEDBACK READING LOST
33419	FLOW CONTROL VALVE - CURRENT FEEDBACK READING LOST
33420	TRACTION LOCK VALVE - SHORT TO BATTERY
33421	TRACTION LOCK VALVE - OPEN CIRCUIT
33422	TRACTION LOCK VALVE - SHORT TO GROUND
33423	OSCILLATING AXLE VALVES - SHORT TO BATTERY
33424	OSCILLATING AXLE VALVES - SHORT TO GROUND
33425	TOWER LIFT VALVES - SHORT TO BATTERY
342	PLATFORM LEVEL UP VALVE - SHORT TO BATTERY
343	PLATFORM LEVEL UP VALVE - SHORT TO GROUND
345	PLATFORM LEVEL DOWN VALVE - OPEN CIRCUIT
346	PLATFORM LEVEL DOWN VALVE - SHORT TO BATTERY
347	PLATFORM LEVEL DOWN VALVE - SHORT TO GROUND
349	PLATFORM ROTATE LEFT VALVE - OPEN CIRCUIT
3410	PLATFORM ROTATE LEFT VALVE - SHORT TO BATTERY
3411	PLATFORM ROTATE LEFT VALVE - SHORT TO GROUND
3412	PLATFORM ROTATE RIGHT VALVE - OPEN CIRCUIT
3413	PLATFORM ROTATE RIGHT VALVE - SHORT TO BATTERY
3414	PLATFORM ROTATE RIGHT VALVE - SHORT TO GROUND
3415	JIB LIFT UP VALVE - OPEN CIRCUIT
3416	JIB LIFT UP VALVE - SHORT TO BATTERY
3417	JIB LIFT UP VALVE - SHORT TO GROUND
3418	JIB LIFT DOWN VALVE - OPEN CIRCUIT
3419	JIB LIFT DOWN VALVE - SHORT TO BATTERY

Table 6-14. System Fault Code Listing

DTC	Analyzer Text
3420	JIB LIFT DOWN VALVE - SHORT TO GROUND
431	FUEL SENSOR - SHORT TO BATTERY
432	FUEL SENSOR - SHORT TO GROUND
433	OIL PRESSURE - SHORT TO BATTERY
434	OIL PRESSURE - SHORT TO GROUND
435	COOLANT TEMPERATURE - SHORT TO GROUND
437	ENGINE TROUBLE CODE
438	HIGH ENGINE TEMP
4310	NO ALTERNATOR OUTPUT
4311	LOW OIL PRESSURE
4313	THROTTLE ACTUATOR FAILURE
4314	WRONG ENGINE SELECTED - ECM DETECTED
4322	LOSS OF ENGINE SPEED SENSOR
4323	SPEED SENSOR READING INVALID SPEED
4326	FUEL ACTUATOR - SHORT TO GROUND
4327	FUEL ACTUATOR - OPEN CIRCUIT
4328	FUEL ACTUATOR - SHORT TO BATTERY
4329	FUEL ACTUATOR - CURRENT FEEDBACK READING TOO LOW
4330	FUEL ACTUATOR - CURRENT FEEDBACK READING LOST
441	BATTERY VOLTAGE TOO LOW - SYSTEM SHUTDOWN
442	BATTERY VOLTAGE TOO HIGH - SYSTEM SHUTDOWN
443	LSS BATTERY VOLTAGE TOO HIGH
444	LSS BATTERY VOLTAGE TOO LOW
445	BATTERY VOLTAGE LOW
662	CANBUS FAILURE - PLATFORM MODULE
663	CANBUS FAILURE - LOAD SENSING SYSTEM MODULE
666	CANBUS FAILURE - ENGINE CONTROLLER
6613	CANBUS FAILURE - EXCESSIVE CANBUS ERRORS
6622	CANBUS FAILURE - TCU MODULE
6629	CANBUS FAILURE - TELEMATICS CANBUS LOADING TOO HIGH
681	REMOTE CONTRACT MANAGEMENT OVERRIDE - ALL FUNCTIONS IN CREEP
813	CHASSIS TILT SENSOR NOT CALIBRATED
814	CHASSIS TILT SENSOR OUT OF RANGE
815	CHASSIS TILT SENSOR DISAGREEMENT
821	LSS CELL #1 ERROR
822	LSS CELL #2 ERROR
823	LSS CELL #3 ERROR
824	LSS CELL #4 ERROR
825	LSS HAS NOT BEEN CALIBRATED
826	RUNNING AT CREEP - PLATFORM OVERLOADED
827	DRIVE & BOOM PREVENTED - PLATFORM OVERLOADED
828	LIFT UP & TELE OUT PREVENTED - PLATFORM OVERLOADED

**Table 6-14. System Fault Code Listing**

<b>DTC</b>	<b>Analyzer Text</b>
8211	LSS READING UNDER WEIGHT
8639	FRONT LEFT STEER VALVE - OPEN CIRCUIT
8640	FRONT LEFT STEER VALVE - SHORT TO BATTERY
8641	FRONT LEFT STEER VALVE - SHORT TO GROUND
8642	FRONT RIGHT STEER VALVE - OPEN CIRCUIT
8643	FRONT RIGHT STEER VALVE - SHORT TO BATTERY
8644	FRONT RIGHT STEER VALVE - SHORT TO GROUND
8669	OSCILLATING AXLE SWITCH DISAGREEMENT
991	LSS WATCHDOG RESET
992	LSS EEPROM ERROR
993	LSS INTERNAL ERROR - PIN EXCITATION
994	LSS INTERNAL ERROR - DRDY MISSING FROM A/D
998	EEPROM FAILURE - CHECK ALL SETTINGS
9910	FUNCTIONS LOCKED OUT - PLATFORM MODULE SOFTWARE VERSION IMPROPER
9911	FUNCTIONS LOCKED OUT - LSS MODULE SOFTWARE VERSION IMPROPER
9915	CHASSIS TILT SENSOR NOT GAIN CALIBRATED
9919	GROUND SENSOR REF VOLTAGE OUT OF RANGE
9920	PLATFORM SENSOR REF VOLTAGE OUT OF RANGE
9921	GROUND MODULE FAILURE - HIGH SIDE DRIVER CUTOUT FAULTY
9922	PLATFORM MODULE FAILURE - HWFS CODE 1
9923	GROUND MODULE FAILURE - HWFS CODE 1
9924	FUNCTIONS LOCKED OUT - MACHINE NOT CONFIGURED
9944	CURRENT FEEDBACK GAINS OUT OF RANGE
9945	CURRENT FEEDBACK CALIBRATION CHECKSUM INCORRECT
9949	MACHINE CONFIGURATION OUT OF RANGE - CHECK ALL SETTINGS
9977	LSS CORRUPT EEPROM
9979	FUNCTIONS LOCKED OUT - GROUND MODULE SOFTWARE VERSION IMPROPER
9986	GROUND MODULE VLOW FET FAILURE

Table 6-15. Fault Code Troubleshooting Information

Help Message	DTC	Condition Producing DTC	Control System Response or Machine Condition	Corrective Action/ Operational Requirement for Function Movement and/or to Clear Fault
EVERYTHING OK or GROUND MODE OK	001 <sup>1</sup>	The platform station (EVERYTHING OK) or ground station (GROUND MODE OK) is selected and the system detects no problems exist.	No response required.	-
RUNNING AT CUTBACK – OUT OF TRANSPORT POSITION	0010 <sup>1</sup>	Tower Elevation Switch shows tower is elevated out of transport position or Boom Elevation Switch #1 shows boom elevated out of transport position or Boom Elevation Switch #2 shows boom elevated out of transport position	Machine is considered Out Of Transport Position	Lower boom into transport position
FSW OPEN	0011 <sup>1</sup>	Machine is in Platform Mode Drive/Steer or Boom function control is activated when Footswitch not engaged	Machine is not allowed to enter the Machine Enabled state	Release controls, Engage Footswitch and reactivate Drive/Steer and/or Boom function control
RUNNING AT CREEP - CREEP SWITCH OPEN	0012 <sup>1</sup>	Machine is in Platform Mode Platform creep switch is turned on	Creep Mode is active	Turn Platform creep switch off
RUNNING AT CREEP - TILTED AND ABOVE ELEVATION	0013 <sup>1</sup>	Fault RUNNING AT CREEP - CREEP SWITCH OPEN (DTC 0012) is <u>not</u> active Machine is Out Of Transport Position Machine chassis is considered Tilted	Creep Mode is active	Lower Machine and place on firm, level surface
RUNNING AT CREEP – PLAT-FORM STOWED	0030 <sup>1</sup>	Platform is in Stowed Position	Lift Down and Level Down function speed maximums are limited to Ground Creep	Raise Platform from Stowed Position
LOAD SENSOR READING UNDER WEIGHT	0015	LSS has been calibrated and the UGM has determined that the load sensing system reading is less than -50lbs for 2 seconds. If the load sensing system determines that the reading is greater than -50lbs for 5 seconds this fault will no longer be annunciated.  No control system interlocks present when DTC is active.		Ensure platform is not resting on the ground or is not leveled at an extreme negative angle.  Re-calibrate the load sensing system if the above items are not a factor.
FUEL LEVEL LOW – ENGINE SHUTDOWN	0031	Engine Shutdown has occurred due to Fuel Level being EMPTY	Machine prohibits engine cranking and throttle functions	Add fuel to fuel tank
APU ACTIVE	0035	Emergency Descent Mode is active	Operation specified in Emergency Descent Mode section	Stop using Emergency Descent Mode
KEYSWITCH FAULTY	212	Both Ground and Platform Keyswitches are energized at the same time	The Control System assumes a station selection of Ground	On Analyzer under DIAGNOSTICS-->SYSTEM-->PLATFORM SELECT (and GROUND SELECT), activate Platform and Ground keyswitches to determine fault location; then troubleshoot wiring and/or keyswitch.
FSW FAULTY	213	The ground footswitch input and platform footswitch input have been both engaged or disengaged for a time period greater than or equal to 1 second	Machine does not allow any functions	Use the Emergency Stop Switch to cycle power

Table 6-15. Fault Code Troubleshooting Information

Help Message	DTC	Condition Producing DTC	Control System Response or Machine Condition	Corrective Action/ Operational Requirement for Function Movement and/or to Clear Fault
FUNCTION PROBLEM - STEER LEFT PERMANENTLY SELECTED	224	The machine is in Platform mode and the Steer Left switch is energized at startup	Machine enters Creep Mode and Steer Left and Right are prohibited	Enable machine and on Analyzer under DIAGNOSTICS-->DRIVE/STEER-->STEER DEMAND, observe Steer Left and Right commands; open Platform box and troubleshoot wiring or replace joystick.
FUNCTION PROBLEM - STEER RIGHT PERMANENTLY SELECTED	225	The machine is in Platform mode and the Steer Right switch is energized at startup	Machine enters Creep Mode and Steer Left and Right are prohibited	Enable machine and on Analyzer under DIAGNOSTICS-->DRIVE/STEER-->STEER DEMAND, observe Steer Left and Right commands; open Platform box and troubleshoot wiring or replace joystick.
STEER SWITCHES FAULTY	227	Both steer switch inputs on the Drive/Steer joystick are energized at startup (Platform or Ground mode).	Drive and Steer are prohibited.	Enable machine and on Analyzer under DIAGNOSTICS-->DRIVE/STEER-->STEER DEMAND, observe Steer Left and Right commands; open Platform box and troubleshoot wiring or replace joystick.
FSW INTERLOCK TRIPPED	2211	Machine is in Platform Mode. The footswitch is depressed for a time period greater than or equal to 7 seconds without activation of any functions	The Machine Enabled function is disabled	Release the footswitch
DRIVE LOCKED - JOYSTICK MOVED BEFORE FOOTSWITCH	2212	The Control System detects one of the following conditions:  The machine is in Platform Mode and the drive joystick is not in the neutral position immediately following Start Up.  The machine is in Platform Mode and the footswitch is depressed or DTC 2213, 2221, or 2223 are active while the drive joystick is not in the neutral position.	If caused by the drive joystick not being in the neutral position immediately following the startup period then disable drive and steer  If caused by engaging footswitch while the drive joystick is not in the neutral position, then do not allow the machine to enter the Machine Enabled state	If caused by the drive joystick not being in the neutral position immediately following Start Up, then return Drive joystick to its neutral position before depressing footswitch  If caused by footswitch being depressed while the drive joystick is not in the neutral position then release the footswitch, return the Drive joystick to neutral and depress the footswitch again
STEER LOCKED - SELECTED BEFORE FOOTSWITCH	2213	The Ground Module detects that the machine is in Platform Mode and the footswitch is depressed or DTC 2212, 2221 or 2223 is active while the steer controls are not in the neutral position.	Do not allow the machine to enter the Machine Enabled state	Steer controls are returned to neutral and the footswitch is released

Table 6-15. Fault Code Troubleshooting Information

Help Message	DTC	Condition Producing DTC	Control System Response or Machine Condition	Corrective Action/ Operational Requirement for Function Movement and/or to Clear Fault
D/S JOY. OUT OF RANGE HIGH	2216	The Platform Module detects that the drive/steer joystick voltage is out of range	The Control System disables Drive; Brake release and Steer still permitted	The Platform Module detects the voltage is in range and no longer reports the fault. Move joystick through range of motion and check voltage (should be approximately 0.7-6.3V).
D/S JOY. CENTER TAP BAD	2217	The Platform Module detects that the drive/steer center tap voltage is out of range	The Control System disables Drive; Brake release and Steer still permitted	The Platform Module detects the voltage is in range and no longer reports the fault
L/S JOY. OUT OF RANGE HIGH	2219	The Platform Module detects that the Lift/Swing joystick reference voltage is high	Disable Lift and Swing in Platform Mode	The Platform Module no longer reports the fault
L/S JOY. CENTER TAP BAD	2220	The Platform Module detects that the Lift/Swing center tap voltage is out of range	Disable Lift and Swing in Platform Mode.	The Platform Module detects that the lift/swing center tap voltage is in range and no longer reports the fault
LIFT/SWING LOCKED - JOYSTICK MOVED BEFORE FOOTSWITCH	2221	The Ground Module detects one of the following conditions:  The machine is in Platform Mode and the Lift and/or Swing controls are not in the neutral position immediately following Start Up.  The machine is in Platform Mode and the footswitch is depressed or DTC 2212, 2213 or 2223 are active while the Lift/Swing joystick is not in the neutral position.	If fault occurs at startup, disable Lift and Swing in Platform Mode  If fault occurs by engaging the footswitch after the control, then machine is not permitted to enter the Machine Enabled state.	Return Lift/Swing controls to neutral while not in the Enabled state.  Return Lift/Swing controls to neutral and release the footswitch
WAITING FOR FSW TO BE OPEN	2222	Machine is in Platform Mode Footswitch has been engaged since Start Up	Machine is not allowed to enter the Machine Enabled state	Release the Footswitch
FUNCTION SWITCHES LOCKED - SELECTED BEFORE ENABLE	2223	The machine is in Platform Mode and the footswitch is depressed or DTC 2212, 2213, or 2221 is active while any of the following boom control inputs are engaged: Tower Lift Telescope Platform Level Platform Rotate Jib Lift	Machine is not allowed to enter the Machine Enabled state	Release engaged control switch and then depress footswitch
FOOTSWITCH SELECTED BEFORE START	2224	Machine is in Platform mode The footswitch is already engaged when an engine start is attempted from the platform controls	Disable engine start	Release the footswitch before attempting to start the engine
FUNCTION PROBLEM - PLATFORM ROTATE LEFT PERMANENTLY SELECTED	2247	The machine is in Platform mode and the platform rotate switch is sending a continual left rotate signal.	Machine enters Creep Mode and Platform Rotate Left and Right prohibited.	Release the footswitch and return the platform rotate switch to neutral. Actuate switch while monitoring state changes under appropriate menu in DIAGNOSTICS-->OPER CONTROLS on Analyzer. Replace the switch if faulty.



**Table 6-15. Fault Code Troubleshooting Information**

Help Message	DTC	Condition Producing DTC	Control System Response or Machine Condition	Corrective Action/ Operational Requirement for Function Movement and/or to Clear Fault
FUNCTION PROBLEM - PLATFORM ROTATE RIGHT PERMANENTLY SELECTED	2248	The machine is in Platform mode and the platform rotate switch is sending a continual right rotate signal.	Machine enters Creep Mode and Platform Rotate Left and Right prohibited.	Release the footswitch and return the platform rotate switch to neutral. Actuate switch while monitoring state changes under appropriate menu in DIAGNOSTICS-->OPER CONTROLS on Analyzer. Replace the switch if faulty.
FUNCTION PROBLEM - JIB LIFT UP PERMANENTLY SELECTED	2249	The machine is in Platform mode and the jib lift switch is sending a continual lift up signal.	Machine enters Creep Mode and Platform Jib Lift Up and Down prohibited.	Release the footswitch and return the platform jib lift switch to neutral. Actuate switch while monitoring state changes under appropriate menu in DIAGNOSTICS-->OPER CONTROLS on Analyzer. Replace the switch if faulty.
FUNCTION PROBLEM - JIB LIFT DOWN PERMANENTLY SELECTED	2250	The machine is in Platform mode and the jib lift switch is sending a continual lift down signal.	Machine enters Creep Mode and Platform Jib Lift Up and Down prohibited.	Release the footswitch and return the platform jib lift switch to neutral. Actuate switch while monitoring state changes under appropriate menu in DIAGNOSTICS-->OPER CONTROLS on Analyzer. Replace the switch if faulty.
FUNCTION PROBLEM - TELESCOPE IN PERMANENTLY SELECTED	2251	The machine is in Platform mode and the telescope switch is sending a continual telescope in signal.	Machine enters Creep Mode and Tele In and Out prohibited.	Release the footswitch and return the telescope switch to neutral. Actuate switch while monitoring state changes under appropriate menu in DIAGNOSTICS-->OPER CONTROLS on Analyzer. Replace the switch if faulty.
FUNCTION PROBLEM - TELESCOPE OUT PERMANENTLY SELECTED	2252	The machine is in Platform mode and the telescope switch is sending a continual telescope out signal.	Machine enters Creep Mode and Tele In and Out prohibited.	Release the footswitch and return the telescope switch to neutral. Replace the switch if faulty.
FUNCTION PROBLEM - TOWER LIFT UP PERMANENTLY SELECTED	2257	The machine is in Platform mode and the tower lift switch is sending a continual tower lift up signal.	Machine enters Creep Mode and Tower Lift Up and Down prohibited.	Release the footswitch and return the telescope switch to neutral. Actuate switch while monitoring state changes under appropriate menu in DIAGNOSTICS-->OPER CONTROLS on Analyzer. Replace the switch if faulty.

Table 6-15. Fault Code Troubleshooting Information

Help Message	DTC	Condition Producing DTC	Control System Response or Machine Condition	Corrective Action/ Operational Requirement for Function Movement and/or to Clear Fault
FUNCTION PROBLEM - TOWER LIFT DOWN PERMANENTLY SELECTED	2258	The machine is in Platform mode and the tower lift switch is sending a continual tower lift down signal.	Machine enters Creep Mode and Tower Lift Up and Down prohibited.	Release the footswitch and return the telescope switch to neutral. Actuate switch while monitoring state changes under appropriate menu in DIAGNOSTICS-->OPER CONTROLS on Analyzer. Replace the switch if faulty.
FUNCTION PROBLEM - PLATFORM LEVEL UP PERMANENTLY SELECTED	2262	The machine is in Platform mode and the platform level up switch is sending a continual level up signal.	Machine enters Creep Mode and Platform Level Up and Down prohibited.	Release the footswitch and return the platform level switch to neutral. Actuate switch while monitoring state changes under appropriate menu in DIAGNOSTICS-->OPER CONTROLS on Analyzer. Replace the switch if faulty.
FUNCTION PROBLEM - PLATFORM LEVEL DOWN PERMANENTLY SELECTED	2263	The machine is in Platform mode and the platform level down switch is sending a continual level up signal.	Machine enters Creep Mode and Platform Level Up and Down prohibited.	Release the footswitch and return the platform level switch to neutral. Actuate switch while monitoring state changes under appropriate menu in DIAGNOSTICS-->OPER CONTROLS on Analyzer. Replace the switch if faulty.
FUNCTION SWITCHES FAULTY - CHECK DIAGNOSTICS/BOOM	234	The Ground Module detects one of the following conditions:  The machine is in Ground Mode and both direction inputs of the following boom controls are energized at the same time: Engine Start/Aux, Telescope, Platform Level, Platform Rotate, Jib Lift, Tower Lift, Lift, or Swing.  The machine is in Platform Mode and both direction inputs of the following boom controls are energized at the same time: Engine Start/Aux, Telescope, Platform Level, Platform Rotate, Jib Lift, Tower Lift	The boom function that is triggering the fault is disabled. <b>NOTE: If Engine Start/Aux Power is at fault, Emergency Descent will still be permitted.</b>	Check the switch for the applicable function. Actuate switch while monitoring state changes under appropriate menu in DIAGNOSTICS-->OPER CONTROLS on Analyzer. Replace if faulty.
FUNCTION SWITCHES LOCKED - SELECTED BEFORE AUX POWER	235	The Ground Module detects one of the following conditions:  The machine is in Ground Mode, the engine is stopped, and the ground Auxiliary Descent switch is selected after a Ground control switch has been selected.  The machine is in Platform Mode, the engine is stopped, and the platform Auxiliary Descent switch is selected after a Platform control switch has been selected.	Emergency Descent mode is disabled	Release all function switches. Activate the Auxiliary Descent switch <i>before</i> any other applicable control switches or start the engine

## SECTION 6 - JLG CONTROL SYSTEM

**Table 6-15. Fault Code Troubleshooting Information**

Help Message	DTC	Condition Producing DTC	Control System Response or Machine Condition	Corrective Action/ Operational Requirement for Function Movement and/or to Clear Fault
FUNCTION SWITCHES LOCKED - SELECTED BEFORE START SWITCH	236	The Ground Module detects one of the following conditions:  The machine is in Ground Mode, the engine is stopped, and any boom control is selected before the ground engine start switch is selected.  The machine is in Platform Mode, the engine is stopped, any drive/steer or boom control is already engaged and the foot-switch is not engaged before the platform engine start switch is selected	Engine start is disabled	Release all function switches. Start the engine <i>before</i> any other applicable function switches are selected.
START SWITCH LOCKED - SELECTED BEFORE KEY-SWITCH	237	The engine start switch for the selected station is engaged during the Ground Module startup sequence.	Engine start is disabled	Release the engine start switch. Position the Ground/ Platform Select switch to the opposite operating station to verify the engine can be started. View switch state on Analyzer under DIAGNOSTICS-->OPER CONTROLS-->START SWITCH.
FUNCTION PROBLEM - GROUND ENABLE PERMANENTLY SELECTED	2310	The machine is in Ground mode and the Enable switch is in the selected position.	Disable Start and Boom functions, including Emergency Descent.	Return the switch to the off position. View switch state on Analyzer under DIAGNOSTICS-->OPER CONTROLS-->AUX DESCENT SW. Replace the switch if defective.
FUNCTION PROBLEM - JIB LIFT UP PERMANENTLY SELECTED	2370	The machine is in Ground mode and the Jib Lift switch is selected and trying to activate the Jib Lift Up function at startup.	Jib Lift Up and Down prohibited.	With the machine controls not enabled, return the Jib Lift switch to neutral. Actuate switch while monitoring state changes under appropriate menu in DIAGNOSTICS-->OPER CONTROLS on Analyzer. Replace the switch if defective.
FUNCTION PROBLEM - JIB LIFT DOWN PERMANENTLY SELECTED	2371	The machine is in Ground mode and the Jib Lift switch is selected and trying to activate the Jib Lift Down function at startup.	Jib Lift Up and Down prohibited.	With the machine controls not enabled, return the Jib Lift switch to neutral. Actuate switch while monitoring state changes under appropriate menu in DIAGNOSTICS-->OPER CONTROLS on Analyzer. Replace the switch if defective.
FUNCTION PROBLEM - SWING LEFT PERMANENTLY SELECTED	2372	The machine is in Ground mode and the Swing switch is selected and trying to activate the Swing Left function at startup.	Swing Left and Right prohibited.	With the machine controls not enabled, return the Swing switch to neutral. Actuate switch while monitoring state changes under appropriate menu in DIAGNOSTICS-->OPER CONTROLS on Analyzer. Replace the switch if defective.

Table 6-15. Fault Code Troubleshooting Information

Help Message	DTC	Condition Producing DTC	Control System Response or Machine Condition	Corrective Action/ Operational Requirement for Function Movement and/or to Clear Fault
FUNCTION PROBLEM - SWING RIGHT PERMANENTLY SELECTED	2373	The machine is in Ground mode and the Swing switch is selected and trying to activate the Swing Right function at startup.	Swing Left and Right prohibited.	With the machine controls not enabled, return the Swing switch to neutral. Actuate switch while monitoring state changes under appropriate menu in DIAGNOSTICS-->OPER CONTROLS on Analyzer. Replace the switch if defective.
BOOM TRANSPORT SWITCH DISAGREEMENT	23104	The Ground Module detects that Boom Elevation switch #1 and switch #2 are not in agreement for more than 4 seconds while lifting.	The Ground Module assumes an "Above Elevation" condition and does not allow Axle Oscillation.	Verify that the two boom angle switches are adjusted to actuate simultaneously. Cycle Power.
FUNCTION PROBLEM - TOWER LIFT UP PERMANENTLY SELECTED	23105	The machine is in Ground mode and the Tower Lift switch is selected and trying to activate the Tower Lift Up function at startup.	Tower Lift Up and Down prohibited.	With the machine controls not enabled, return the Tower Lift switch to neutral. Actuate switch while monitoring state changes under appropriate menu in DIAGNOSTICS-->OPER CONTROLS on Analyzer. Replace the switch if defective.
FUNCTION PROBLEM - TOWER LIFT DOWN PERMANENTLY SELECTED	23106	The machine is in Ground mode and the Tower Lift switch is selected and trying to activate the Tower Lift Down function at startup.	Tower Lift Up and Down prohibited.	With the machine controls not enabled, return the Tower Lift switch to neutral. Actuate switch while monitoring state changes under appropriate menu in DIAGNOSTICS-->OPER CONTROLS on Analyzer. Replace the switch if defective.
FUNCTION PROBLEM - LIFT UP PERMANENTLY SELECTED	23107	The machine is in Ground mode and the Lift switch is selected and trying to activate the Lift Up function at startup.	Lift Up and Down prohibited.	With the machine controls not enabled, return the Lift switch to neutral. Actuate switch while monitoring state changes under appropriate menu in DIAGNOSTICS-->OPER CONTROLS on Analyzer. Replace the switch if defective.
FUNCTION PROBLEM - LIFT DOWN PERMANENTLY SELECTED	23108	The machine is in Ground mode and the Lift switch is selected and trying to activate the Lift Down function at startup.	Lift Up and Down prohibited.	With the machine controls not enabled, return the Lift switch to neutral. Actuate switch while monitoring state changes under appropriate menu in DIAGNOSTICS-->OPER CONTROLS on Analyzer. Replace the switch if defective.

**Table 6-15. Fault Code Troubleshooting Information**

Help Message	DTC	Condition Producing DTC	Control System Response or Machine Condition	Corrective Action/ Operational Requirement for Function Movement and/or to Clear Fault
FUNCTION PROBLEM - TELESCOPE IN PERMANENTLY SELECTED	23109	The machine is in Ground mode and the Telescope switch is selected and trying to activate the Telescope In function at startup.	Tele In and Out prohibited.	With the machine controls not enabled, return the Lift switch to neutral. Actuate switch while monitoring state changes under appropriate menu in DIAGNOSTICS-->OPER CONTROLS on Analyzer. Replace the switch if defective.
FUNCTION PROBLEM - TELESCOPE OUT PERMANENTLY SELECTED	23110	The machine is in Ground mode and the Telescope switch is selected and trying to activate the Telescope Out function at startup.	Tele In and Out prohibited.	With the machine controls not enabled, return the Lift switch to neutral. Actuate switch while monitoring state changes under appropriate menu in DIAGNOSTICS-->OPER CONTROLS on Analyzer. Replace the switch if defective.
FUNCTION PROBLEM - PLATFORM LEVEL UP PERMANENTLY SELECTED	23111	The machine is in Ground mode and the Platform Level switch is selected and trying to activate the Platform Level Up function at startup.	Platform Level Up and Down prohibited.	With the machine controls not enabled, return the Lift switch to neutral. Actuate switch while monitoring state changes under appropriate menu in DIAGNOSTICS-->OPER CONTROLS on Analyzer. Replace the switch if defective.
FUNCTION PROBLEM - PLATFORM LEVEL DOWN PERMANENTLY SELECTED	23112	The machine is in Ground mode and the Platform Level switch is selected and trying to activate the Platform Level Down function at startup.	Platform Level Up and Down prohibited.	With the machine controls not enabled, return the Lift switch to neutral. Actuate switch while monitoring state changes under appropriate menu in DIAGNOSTICS-->OPER CONTROLS on Analyzer. Replace the switch if defective.
FUNCTION PROBLEM - PLATFORM ROTATE LEFT PERMANENTLY SELECTED	23113	The machine is in Ground mode and the Platform Rotate switch is selected and trying to activate the Platform Rotate Left function at startup.	Platform Rotate Right and Left prohibited.	With the machine controls not enabled, return the Lift switch to neutral. Actuate switch while monitoring state changes under appropriate menu in DIAGNOSTICS-->OPER CONTROLS on Analyzer. Replace the switch if defective.
FUNCTION PROBLEM - PLATFORM ROTATE RIGHT PERMANENTLY SELECTED	23114	The machine is in Ground mode and the Platform Rotate switch is selected and trying to activate the Platform Rotate Right function at startup.	Platform Rotate Right and Left prohibited.	With the machine controls not enabled, return the Lift switch to neutral. Actuate switch while monitoring state changes under appropriate menu in DIAGNOSTICS-->OPER CONTROLS on Analyzer. Replace the switch if defective.

Table 6-15. Fault Code Troubleshooting Information

Help Message	DTC	Condition Producing DTC	Control System Response or Machine Condition	Corrective Action/ Operational Requirement for Function Movement and/or to Clear Fault
ROD SIDE PRESSURE SENSOR – FAULTY	23217*	After the operator demand is complete (enable valve de-energized after a tower lift down or boom lift down) and footswitch still active, the flow control directional valves are appropriately held for 3sec to check the tower lift enable valve. This diagnostic is run at the same time as DTC 33563 If Rod side pressure is greater than 1800psi or less than 1000psi, fault is detected Fault, once triggered, is maintained within a given key-cycle Machine will be trapped in transport		Check relief setting or pressure transducer
*This fault will not be active if Boom Sensors are not calibrated, a subsequent function is activated, any retrieval mode is active, any valves or sensors involved in the diagnostics are not healthy, ground mode is selected or dump valve is energized for less than 3sec after a function is complete				
MODEL CHANGED – HYDRAULICS SUSPENDED – CYCLE EMS	259	The MACHINE SETUP → MODEL is changed using the analyzer	All of the boom, drive, and steer functions are disabled; the engine will be shut down.	Cycle Power.
GENERATOR MOTION CUTOFF ACTIVE	2513	MACHINE SETUP → GEN SET = BELT DRIVE and GEN SET CUTOFF = MOTION CUTOFF The machine is being operated in Platform mode and the footswitch and Generator Enable switch are engaged while any of the configured boom, drive, or steer functions are attempting to be activated.	All of the boom, drive, and steer functions are disabled.	Motion is no longer attempted or generator is turned off.
BOOM PREVENTED – DRIVE SELECTED	2514	The machine is set up to cut out boom functions when the drive or steer is being operated. The machine is in the Out of Transport position and the operator is operating a Drive or Steer function and attempts to activate a boom function. Note: DTC 2514 supercedes DTC 2518 if drive/steer and boom functions are both active when the machine changes from Below Elevation to Above Elevation.	All boom functions are disabled.	Stop operating any Drive or Steer functions. Activate the Boom function.
DRIVE PREVENTED – ABOVE ELEVATION	2516	The machine is set up to cut out drive and steer when the boom is above elevation. The machine is in the Out of Transport position. The Control System senses the boom is above elevation and the operator is attempting to activate Drive or Steer	Disable Drive and Steer	Place the machine in the transport position before attempting to drive or steer.
DRIVE PREVENTED – TILTED & ABOVE ELEVATION	2517	The machine is set up to cut out drive and steer when the chassis is tilted and boom is above elevation. The machine is in the Out Of Transport position. The Control System senses the chassis is tilted and the operator is attempting to activate Drive or Steer	Disable Drive and Steer	Place the machine in the transport position before attempting to drive or steer.
DRIVE PREVENTED – BOOM SELECTED	2518	The machine is set up to cut out functions when the boom is being operated. The machine is in the Out Of Transport position. The operator is operating a boom function and tries to activate the Drive or Steer controls.	Disable Drive and Steer	Stop operating any boom functions. Activate the Drive or Steer function.
FUNCTIONS LOCKED OUT – CONSTANT DATA VERSION IMPROPER	2520	The Ground Module detects a mismatch between programmed sections of the processor memory.	Disable all machine and engine functions (i.e., command engine shutdown and do not permit start).	Reprogram the software so that the memory values match. Cycle Power.
RUNNING AT CREEP - PLATFORM LEVELED UNDER	2587	The control system has determined that the platform is leveled under and is being considered to be in a loading/unloading position. Boom, Tower, and Level Override functions will operate at creep speed.		

Table 6-15. Fault Code Troubleshooting Information

Help Message	DTC	Condition Producing DTC	Control System Response or Machine Condition	Corrective Action/ Operational Requirement for Function Movement and/or to Clear Fault
BRAKE – SHORT TO BATTERY	331	The Ground Module detects a short to battery at the brake output.	Disable Drive and Brake outputs.	Inspect wiring for physical damage and check for wire continuity. Cycle power to clear the fault.
BRAKE – OPEN CIRCUIT	332	The Ground Module detects an open circuit at the brake output.	No response required.	Inspect wiring for physical damage. Check for a good connection at the solenoid and for wire continuity through this circuit. Cycle power to clear the fault.
LIFT UP VALVE – OPEN CIRCUIT	334	The Ground Module detects an open circuit at the lift up valve output.	The Ground Module suspends the Lift Up/Down command and reverts to Open Loop Current control for Lift; Lift speed is limited to Creep after both Lift Up/Down controls are returned to neutral and the machine controls are not Enabled.	Inspect wiring for physical damage. Check for a good connection at the solenoid and for continuity through the circuit. With the solenoid disconnected, an open circuit voltage of nearly 8.0V exists on the Ground Module output pin for diagnostic purposes. Cycle power to clear the fault.
LIFT DOWN VALVE – SHORT TO GROUND	335	The Ground Module detects a short to ground at the Lift Down valve output.	Ground Module Lift Up and Down outputs are disabled.	Inspect wiring for physical damage and check for wire continuity. Cycle power to clear the fault.
LIFT DOWN VALVE – OPEN CIRCUIT	336	The Ground Module detects an open circuit at the Lift Down valve output.	The Ground Module suspends Lift Up/Down commands and reverts to Open Loop Current control for Lift; Lift speed is limited to Creep after both Lift Up/Down controls have been returned to neutral and machine is not Enabled.	Check for a good connection at the solenoid and for continuity through this circuit. With the solenoid disconnected, an open circuit voltage of nearly 8.0V exists on the Ground Module output pin for diagnostic purposes. Inspect wiring for physical damage. Cycle power to clear the fault.
GROUND ALARM – SHORT TO BATTERY	3311	The Ground Module detects a short to battery at the Ground Alarm output.	No response required.	Inspect wiring for physical damage and check for wire continuity. Cycle power to clear the fault.
MAIN DUMP VALVE – SHORT TO GROUND	3358	The Ground Module detects a short to ground at the Main Dump Valve output.	The Main Dump Valve output is disabled.	Inspect wiring for physical damage and check for wire continuity. Cycle power to clear the fault.

Table 6-15. Fault Code Troubleshooting Information

Help Message	DTC	Condition Producing DTC	Control System Response or Machine Condition	Corrective Action/Operational Requirement for Function Movement and/or to Clear Fault
MAIN DUMP VALVE – OPEN CIRCUIT	3359	The Ground Module detects an open circuit at the Main Dump Valve output.	No response required.	Check for a good connection at the solenoid and for continuity through this circuit. With the solenoid disconnected, an open circuit voltage of nearly 8.0V exists on the Ground Module output pin for diagnostic purposes. Inspect wiring for physical damage. Cycle power to clear the fault.
MAIN DUMP VALVE – SHORT TO BATTERY	3360	The Ground Module detects a short to battery at the Main Dump Valve output.	Ground Module Main Dump, Swing Left/Right, Tower Lift Up, and Lift Up outputs are disabled.	Inspect wiring for physical damage and check for wire continuity. Cycle power to clear the fault.
BRAKE – SHORT TO GROUND	3361	The Ground Module detects a short to ground at the Brake output.	Ground Module Drive/Steer and Brake outputs are disabled.	Inspect wiring for physical damage and check for wire continuity. Cycle power to clear the fault.
START SOLENOID – SHORT TO GROUND	3362	The Ground Module detects a short to ground at the Engine Starter Solenoid.	Engine Start attempt is not permitted.	Inspect wiring for physical damage and check for wire continuity. Cycle power to clear the fault.
START SOLENOID – OPEN CIRCUIT	3363	Ground Module detects an open circuit at this output; if machine is equipped with a Dual Fuel ECU, ground module will only evaluate for open circuit conditions until first Start is attempted for each power cycle due to possibility of ECU opening ground solenoid return path to disable Start and causing erroneous diagnostics.	No response required.	Inspect wiring for physical damage and check for wire continuity. Cycle power to clear the fault.
START SOLENOID – SHORT TO BATTERY	3364	The Ground Module detects a short to battery at the Engine Starter Solenoid.	Ground Module Engine Start is disabled by de-energizing the Fuel Actuator (Kubota) or sending an Engine Shutdown command (Dual Fuel ECU)	Inspect wiring for physical damage and check for wire continuity. Cycle power to clear the fault.
STEER DUMP VALVE – SHORT TO GROUND	3365	The Ground Module detects a short to ground at the Steer Dump Valve output.	Ground Module Steer Dump output is disabled.	Inspect wiring for physical damage and check for wire continuity. Cycle power to clear the fault.
STEER DUMP VALVE – OPEN CIRCUIT	3366	The Ground Module detects an open circuit at the Steer Dump Valve output.	No response required.	Check for a good connection at the solenoid and for continuity through this circuit. With the solenoid disconnected, an open circuit voltage of nearly 8.0V exists on the Ground Module output pin for diagnostic purposes. Inspect wiring for physical damage. Cycle power to clear the fault.



Table 6-15. Fault Code Troubleshooting Information

Help Message	DTC	Condition Producing DTC	Control System Response or Machine Condition	Corrective Action/ Operational Requirement for Function Movement and/or to Clear Fault
STEER DUMP VALVE – SHORT TO BATTERY	3367	The Ground Module detects a short to battery at the Steer Dump Valve output.	Ground Module Steer Dump, Steer, and Flow Control outputs are disabled; Steer, Tele In/Out, Jib Up (permitted if operating in Emergency Descent mode), Level Up/Down, and Rotate Left/Right functions are disallowed.	Inspect wiring for physical damage and check for wire continuity. Cycle power to clear the fault.
GEN SET/WELDER – SHORT TO GROUND	3373	The Ground Module detects a short to ground at the Gen Set/Welder output.	Ground Module Generator relay output is disabled thereby disabling generator functionality.	Inspect wiring for physical damage and check for wire continuity. Cycle power to clear the fault.
GEN SET/WELDER – OPEN CIRCUIT	3374	The Ground Module detects an open circuit at the Gen Set/Welder output.	No response required.	Check for a good connection at the relay and for continuity through this circuit. With the relay disconnected, an open circuit voltage of nearly 8.0V exists on the Ground Module output pin for diagnostic purposes. Inspect wiring for physical damage. Cycle power to clear the fault.
GEN SET/WELDER – SHORT TO BATTERY	3375	The Ground Module detects a short to battery at the Gen Set/Welder output.	The Ground Module Generator relay output is disabled, but the Ground Module considers the Generator always enabled and restricts engine speed to Generator RPM. If MACHINE SETUP → GENSET CUTOFF = MOTION CUTOFF, disregard cutoff and permit motion.	Inspect wiring for physical damage and check for wire continuity. Cycle power to clear the fault.
HEAD TAIL LIGHT – SHORT TO GROUND	3376	The Ground Module detects a short to ground at the Head-Tail Light output.	Ground Module H&T Light relay output is disabled.	Inspect wiring for physical damage and check for wire continuity. Cycle power to clear the fault.
HEAD TAIL LIGHT – OPEN CIRCUIT	3377	The Ground Module detects an open circuit at the Head-Tail Light output.	No response required.	Check for a good connection at the relay and for continuity through this circuit. With the relay disconnected, an open circuit voltage of nearly 8.0V exists on the Ground Module output pin for diagnostic purposes. Inspect wiring for physical damage. Fault cleared with power cycle.

Table 6-15. Fault Code Troubleshooting Information

Help Message	DTC	Condition Producing DTC	Control System Response or Machine Condition	Corrective Action/ Operational Requirement for Function Movement and/or to Clear Fault
HEAD TAIL LIGHT – SHORT TO BATTERY	3378	The Ground Module detects a short to battery at the Head-Tail Light output.	Disable Ground Module H&T Light relay output is disabled.	Inspect wiring for physical damage and check for wire continuity. Cycle power to clear the fault.
HOUR METER – SHORT TO GROUND	3379	The Ground Module detects a short to ground at the Hourmeter output.	Ground Module Hourmeter output is disabled.	Inspect wiring for physical damage and check for wire continuity. Confirm high resistance reading across hourmeter. Cycle power to clear the fault.
HOUR METER – SHORT TO BATTERY	3381	The Ground Module detects a short to battery at the Hourmeter output.	Ground Module Hourmeter output is disabled.	Inspect wiring for physical damage and check for wire continuity. Cycle power to clear the fault.
PLATFORM LEVEL UP VALVE – SHORT TO GROUND	3382	The Ground Module detects a short to ground at the Platform Level Up Valve output.	Ground Module Platform Level Up is disabled; Level Down speed is limited to Creep.	Inspect wiring for physical damage and check for wire continuity. Check for coil damage or shorting condition in connector. Cycle power to clear the fault.
PLATFORM LEVEL UP VALVE – OPEN CIRCUIT	3383	The Ground Module detects an open circuit at the Platform Level Up Valve output.	Platform Level speed is limited to Creep.	Check for a good connection at the solenoid and for continuity through this circuit. Inspect wiring for physical damage. Cycle power to clear the fault.
PLATFORM LEVEL UP VALVE – SHORT TO BATTERY	3384	The Ground Module detects a short to battery at the Platform Level Up Valve output.	Ground Module Platform Level Up, Level Down, and Flow Control Valve outputs are disabled.	Inspect wiring for physical damage and check for wire continuity. Cycle power to clear the fault.
PLATFORM LEVEL DOWN VALVE – SHORT TO GROUND	3388	The Ground Module detects a short to ground at the Platform Level Down Valve output.	Ground Module Platform Level Up and Down valve outputs are disabled.	Inspect wiring for physical damage and check for wire continuity. Check for coil damage or shorting condition in connector. Cycle power to clear the fault.
PLATFORM LEVEL DOWN VALVE – OPEN CIRCUIT	3389	The Ground Module detects an open circuit at the Platform Level Down Valve output.	Platform Level speed is limited to Creep.	Check for a good connection at the solenoid and for continuity through this circuit. Inspect wiring for physical damage. Cycle power to clear the fault.
PLATFORM LEVEL DOWN VALVE – SHORT TO BATTERY	3390	The Ground Module detects a short to battery at the Platform Level Down Valve output.	Ground Module Platform Level Up, Level Down, and Flow Control Valve outputs are disabled.	Inspect wiring for physical damage and check for wire continuity. Cycle power to clear the fault.

**Table 6-15. Fault Code Troubleshooting Information**

Help Message	DTC	Condition Producing DTC	Control System Response or Machine Condition	Corrective Action/ Operational Requirement for Function Movement and/or to Clear Fault
TOWER LIFT UP VALVE – SHORT TO GROUND	33106	The Ground Module detects a short to ground at the Tower Lift Up Valve output.	Ground Module Tower Lift Up output is disabled; Tower Lift Down speed is limited to Creep	Inspect wiring for physical damage and check for wire continuity. Check for coil damage or shorting condition in connector. Cycle power to clear the fault.
TOWER LIFT UP VALVE – OPEN CIRCUIT	33107	The Ground Module detects an open circuit at the Tower Lift Up Valve output.	The Ground Module suspends Tower Lift Up/Down commands and reverts to Open Loop Current control for Tower Lift; Tower Lift speed is limited to Creep after both Tower Lift Up/Down controls have been returned to neutral and machine is not Enabled	Check for a good connection at the solenoid and for continuity through this circuit. With the solenoid disconnected, an open circuit voltage of nearly 8.0V exists on the Ground Module output pin for diagnostic purposes. Inspect wiring for physical damage. Cycle power to clear the fault.
TOWER LIFT DOWN VALVE – SHORT TO GROUND	33109	The Ground Module detects a short to ground at the Tower Lift Down Valve output.	Ground Module Tower Lift Up and Down outputs are disabled.	Inspect wiring for physical damage and check for wire continuity. Check for coil damage or shorting condition in connector. Cycle power to clear the fault.
TOWER LIFT DOWN VALVE – OPEN CIRCUIT	33110	The Ground Module detects an open circuit at the Tower Lift Down Valve output.	The Ground Module suspends Tower Lift Up/Down commands and reverts to Open Loop Current control for Tower Lift; Tower Lift speed is limited to Creep after both Tower Lift Up/Down controls have been returned to neutral and machine is not Enabled	Check for a good connection at the solenoid and for continuity through this circuit. With the solenoid disconnected, an open circuit voltage of nearly 8.0V exists on the Ground Module output pin for diagnostic purposes. Inspect wiring for physical damage. Cycle power to clear the fault.
SWING RIGHT VALVE – SHORT TO GROUND	33118	The Ground Module detects a short to ground at the Swing Right Valve output.	Swing Left and Right outputs are disabled.	Inspect wiring for physical damage and check for wire continuity. Check for coil damage or shorting condition in connector. Cycle power to clear the fault.
SWING RIGHT VALVE – OPEN CIRCUIT	33119	The Ground Module detects an open circuit at the Swing Right Valve output.	The Ground Module suspends Swing Left/Right commands and reverts to Open Loop Current control for Swing; Swing speed is limited to Creep after both Swing Left/Right controls are returned to neutral and machine is not Enabled	Check for a good connection at the solenoid and for continuity through this circuit. With the solenoid disconnected, an open circuit voltage of nearly 8.0V exists on the Ground Module output pin for diagnostic purposes. Inspect wiring for physical damage. Cycle power to clear the fault.

Table 6-15. Fault Code Troubleshooting Information

Help Message	DTC	Condition Producing DTC	Control System Response or Machine Condition	Corrective Action/ Operational Requirement for Function Movement and/or to Clear Fault
TELESCOPE IN VALVE – SHORT TO BATTERY	33120	The Ground Module detects a short to battery at the Telescope In Valve output.	Ground Module Telescope In, Telescope Out, and Flow Control Valve outputs are disabled.	Inspect wiring for physical damage and check for wire continuity. Cycle power to clear the fault.
SWING LEFT VALVE – SHORT TO GROUND	33122	The Ground Module detects a short to ground at the Swing Left Valve output.	Ground Module Swing Left and Right outputs are disabled.	Inspect wiring for physical damage and check for wire continuity. Check for coil damage or shorting condition in connector. Cycle power to clear the fault.
TELESCOPE OUT VALVE – SHORT TO BATTERY	33123	The Ground Module detects a short to battery at the Telescope Out Valve output.	Ground Module Telescope In, Telescope Out, and Flow Control Valve outputs are disabled.	Inspect wiring for physical damage and check for wire continuity. Cycle power to clear the fault.
THROTTLE ACTUATOR – SHORT TO GROUND	33130	The Ground Module detects a short to ground at the Throttle Actuator output (Kubota).	The Ground Module Throttle Actuator output is disabled.	Inspect wiring for physical damage and check for wire continuity. Check for coil damage or shorting condition in connector. Cycle power to clear the fault.
THROTTLE ACTUATOR – OPEN CIRCUIT	33131	The Ground Module detects an open circuit at the Throttle Actuator output (Kubota).	No response required	Check for a good connection at the solenoid and for continuity through this circuit. With the solenoid disconnected, an open circuit voltage of nearly 8.0V exists on the Ground Module output pin for diagnostic purposes. Inspect wiring for physical damage. Cycle power to clear the fault.
THROTTLE ACTUATOR – SHORT TO BATTERY	33132	The Ground Module detects a short to battery at the Throttle Actuator output (Kubota).	The Ground Module Throttle Actuator output is disabled; functions are set to Creep speed.	Inspect wiring for physical damage and check for wire continuity. Cycle power to clear the fault.
LIFT VALVES – SHORT TO BATTERY	33182	The Ground Module detects a short to battery at either the Lift Up or Lift Down valve	The Ground Module Lift Up and Down outputs are disabled and ground current return path is open circuited.	Inspect wiring for physical damage and check for wire continuity. Cycle power to clear the fault.