

TRAILER MOUNTED Z-BOOMS

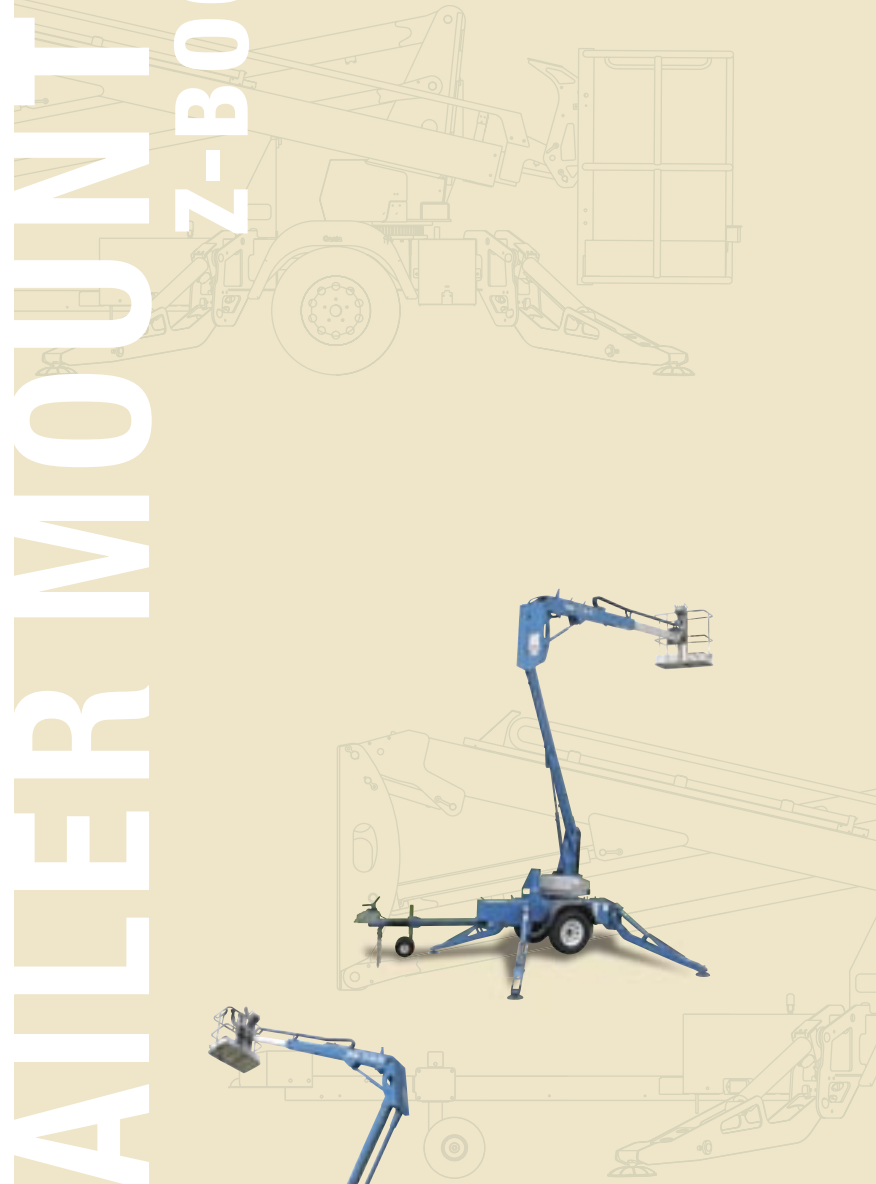

TRAILER MOUNTED Z-BOOMS

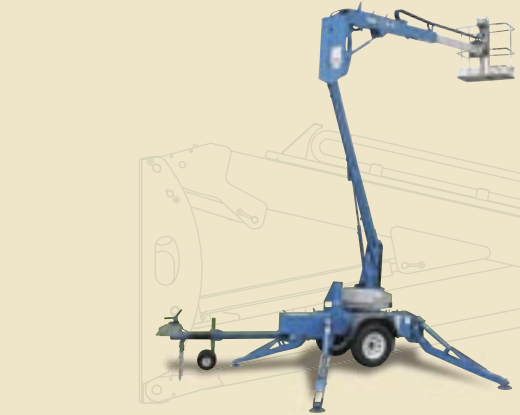

**WHEN YOU NEED A LIFT,
YOU KNOW IT MUST BE A GENIE.**

Genie sets the standard by which other lifts are judged. Simply put, we build a better lift for every job. Genie's full line of products offers you unmatched performance, safety and reliability. As a subsidiary of TEREX Corporation, we offer our customers easy access to a complete range of other products and services across the construction, mining, utility and road building industries.

With almost four decades of experience, Genie provides you with the most advanced lifting equipment in the industry.

The company began in 1966 with the introduction of the Genie Hoist, a portable, pneumatic material lift. Additional lifts and aerial work platforms followed, gaining worldwide recognition with breakthrough designs. Today, Genie remains at the forefront of lifting technology with a commitment to quality production.

Finding new and innovative ways to help you get the job done.

Our efforts to produce better products and harness new technology have earned numerous patents worldwide. Our quality-driven, professional team of engineers continually focus on understanding how our equipment is used so they can design products to meet and exceed your ever-changing needs.

Our team is always working for you. The Genie Service Team is available around the clock providing support when you need it most, which means more "Up Time" for you, our customer. Genie customers also have access to an ever-increasing range of services from financial funding through TEREX Financial Services (TFS) to an aggressive parts support network that ships most parts within 24 hours.

The highest quality standards mean you receive the highest quality products. We set stringent quality standards for each step of the manufacturing process, from design to distribution. Performance is regularly monitored against these standards to ensure superior products. Our goal is to deliver the highest quality products that give you the most value.



Genie
A TEREX COMPANY



HIGHER STANDARDS



INDUSTRY-LEADING DESIGN AND PERFORMANCE

Genie is the world leader in lifts, smart blue lifts to be exact. Genie manufactures the most advanced, highest-valued lift equipment in the industry.

The introduction of the Genie TZ™-34/20 and TZ™-50 have revolutionized the aerial lifting industry by including technology and features that set new standards of excellence in the trailer mounted boom marketplace.

Genie's trailer mounted booms are an excellent value in high-reach equipment, providing several unique features including hydraulic outriggers and automatic machine leveling. The TZ™-50 delivers industry-leading working range, with the flexibility of an optional hybrid DC/gas engine.

DELIVERING SUPERIOR RESULTS

The TZ™-34/20 has an outstanding working envelope that allows operators to reach heights of 40 ft (12.36 m) and an outreach of 18 ft 4 in (5.6 m). With over 16 ft (4.9 m) of “up and over” capabilities, the extremely versatile and easy-to-use TZ™ is an excellent all-around solution.



AUXILIARY PUMP DOWN



FORK LIFT POCKETS

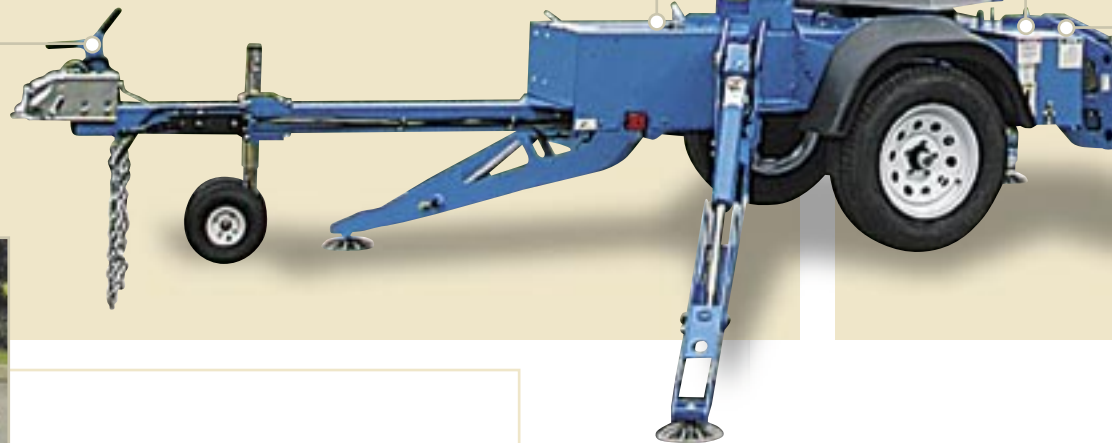

HITCH PULL BAR

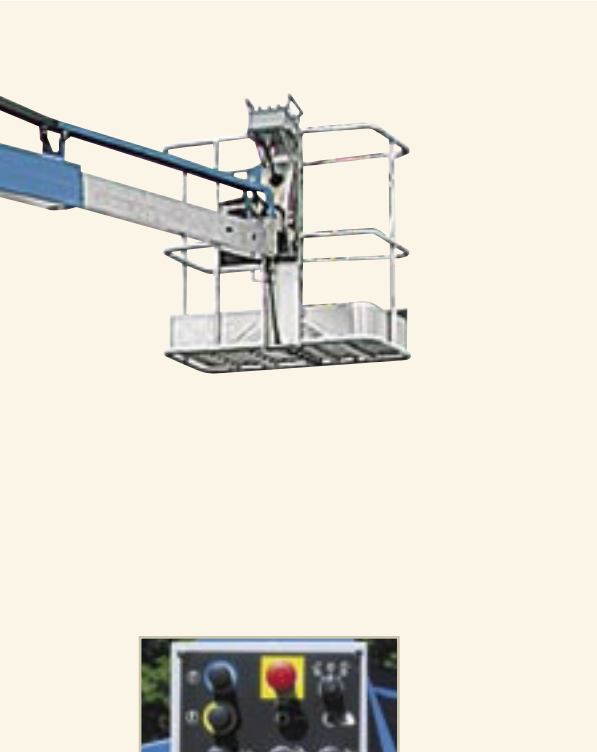

EASY-TO-READ CONTROLS



LEVELING GAUGE



EASY ACCESS TO BATTERIES



STANDARD FEATURES FOR TZ-34/20

Rigid Chassis and Outriggers Design

The TZ-34/20 is an inherently durable unit. The rigid chassis has a heavy-duty base and robust outriggers, making it the best solution for large and small contractors, maintenance crews, painting contractors and rental yards.

Articulating and Telescopic Primary Boom

The articulating boom and telescopic primary boom provide an industry-leading working envelope, allowing the operator to reach areas in the lower height range.

Easy-to-Read Controls

Both ground controls and platform controls feature an easy-to-use pictograph system.

Variable Speed Controller

Variable speed adjustment of all controls provide maximum productivity and control.

Simultaneous Down Function

Ability to lower both boom sections at the same time, providing quicker overall descent time for higher productivity.

Easy to Maneuver and Position

The TZ-34/20 is lightweight and easy to maneuver, position and store. It meets the challenges of the working environment.

Dual Pneumatic Jockey Wheels

Heavy-duty jockey wheels balance the TZ-34/20 for precise positioning of the machine during setup and transportation.

Hydraulic Outriggers with Automatic Leveling System

The exclusive Genie Automatic Leveling System is "self-leveling" and provides 10.5 degree leveling capability. This system allows the operator to hydraulically deploy the outriggers and automatically level the machine from the ground controls. Machine setup can be completed in less than 40 seconds when the operator deploys all four outriggers simultaneously. The system self-levels the machine to 1 degree in all directions.

Easy to Transport

The TZ-34/20 is easily towed behind nearly any vehicle with adequate towing capacity, a 2 in (5.08 cm) ball and a Class 2 hitch. Genie's tow speed rating of 60 mph (97 km/h) allows for fast transportation to job sites.

Simple, Serviceable, Intuitive Control System

The simple and reliable control system offers easy serviceability.

Easy Access to Batteries

Simply release the clamp and remove the cover for easy access to the battery compartment.

INDUSTRY LEADING OUTREACH

The TZ™ 50 is the ultimate in reach and range with a working height of 55 ft 6 in (17.09 m) and over 29 ft (8.9 m) of outreach. With its mobility and 22 ft (6.7 m) of “up and over” clearance, the TZ™ 50 is easy to use and a favorite with contractors and rental yards.



DRIVE AND SET



HYBRID DC/GAS ENGINE



EASY ACCESS TO BATTERY



EASY TO READ CONTROLS



Out and Up Articulating Jib Boom

The articulating jib boom comes standard on the TZ-50 giving you an additional 4 ft 1 in (1.25m) of horizontal reach and 135 degrees of working range for more flexibility. You can access 75 degrees above horizontal as well as 60 degrees below horizontal.

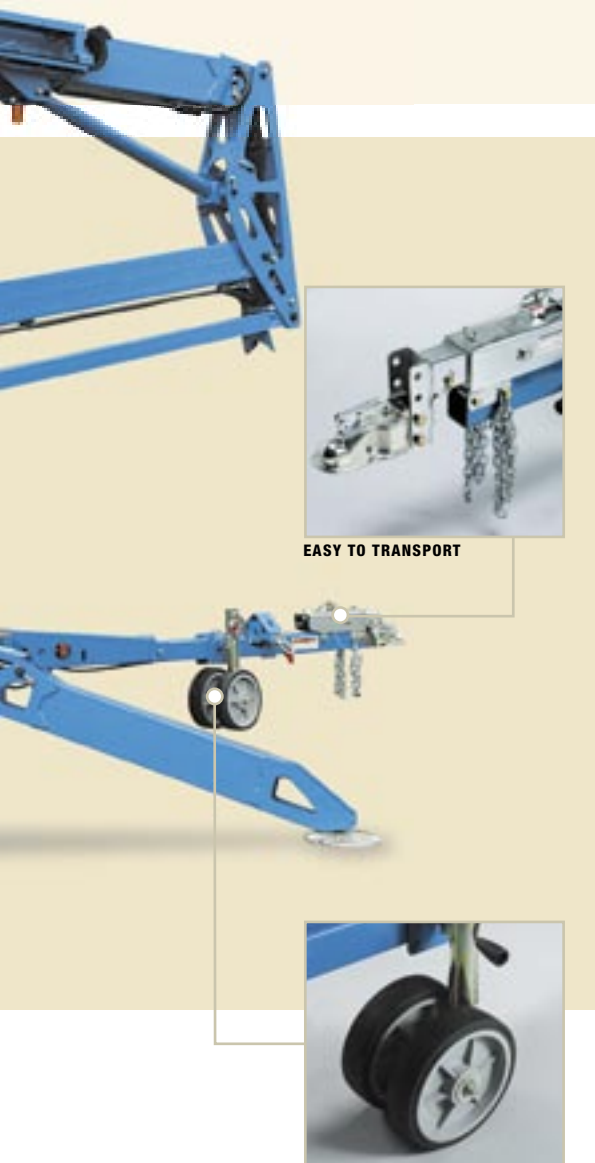

EASY TO TRANSPORT



HEAVY-DUTY JOCKEY WHEELS

STANDARD FEATURES FOR TZ-50

Articulating and Telescopic Primary Boom

Provides industry leading working range.

135 Degree Jib Boom Working Range

A 4 ft 1 in (1.25 m) articulating jib boom allows you to position the platform above or below horizontal.

Easy-To-Use Controls

Both ground and platform controls are easy to use and utilize symbols to simplify operation.

Dual Jockey Wheels

Heavy-duty jockey wheels allow for precise positioning of the machine during setup and transportation.

Automatic Leveling System (patent pending)

The exclusive Genie Automatic Leveling System is “self-leveling” and is standard equipment on all TZ-50 models. This system provides 10.5 degrees leveling capability and allows the operator to hydraulically deploy the outriggers and automatically level the machine. Machine

setup can be completed in less than 45 seconds when the operator deploys all four outriggers simultaneously. The system self-levels the machine to 1 degree in all directions. The level sensor alarm does not sound unless the machine is over 2.5 degrees out of level. This feature increases productivity and sets the Genie TZ-50 apart from the competition.

Large Outrigger Foot Pads

Large outrigger foot pads effectively distribute the machine weight. Non-marking foot pads are offered as an option.

Easy to Transport

The TZ-50 is easily towed behind vehicles that have an adequate capacity, 2 in (5.08 cm) ball and a Class 3 hitch. Several hitch receptacles are available. Genie’s maximum highway tow speed rating of 60 mph (97 km/h) provides fast transportation to job sites.

OPTIONS FOR BOTH MODELS



Platform Rotation

A manual rotate mechanism allows the operator to rotate the platform 80 degrees horizontally in either direction.



Hitch Coupler Options

Choose the type of hitch that best meets your needs from a variety of options.



These trailer mounted booms are an excellent value in high-reach equipment.

TZ-50 OPTIONS

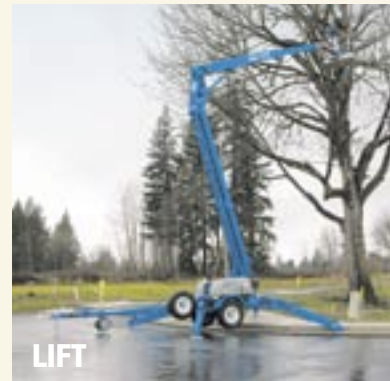

Drive, Set, Lift

Choose the Drive and Set option to have ultimate flexibility in positioning your TZ-50 exactly where you need it. When the platform is in the fully lowered position, you can drive the unit to the area where you need to work, deploy the outriggers and then raise the platform to the level needed. These quick, efficient operations increase your productivity on the job.

Hybrid DC/Gas Engine

Allows machine to charge in remote locations.



TZ-34/20

OPTIONS & ACCESSORIES

Platform Options

- Platform rotation
- Platform overload system

Coupler Options

- Combination hitch and adjustable height coupler system
- 2 in (5.08 cm) ball coupler
- 2.625 in (6.67 cm) ball coupler
- 2.5 in (6.35 cm) I.D. pintle ring coupler - U.S.
- Clevis coupler - U.S.

Accessories

- Tool tray
- Fluorescent tube caddy
- Battery charge indicator (BCI)
- Operational warning light package (flashing beacons)
- Horn
- Non-marking outrigger footpads
- Spare tire
- Wheel chocks

STANDARD COMPLIANCE

- ANSI A92.2
- CAN/CSA-C255-M88
- CE Compliance
- AS 1418.10
- PB-10-611-03



TZ-34/20

WORKING HEIGHT	40 ft	12.36 m
HORIZONTAL REACH	18 ft 4 in	5.6 m
LIFT CAPACITY*		
Standard Platform	500 lbs	227 kg
With Platform Rotation	440 lbs	200 kg

* ANSI, CSA

* Lift capacity varies depending on options and country standards.

TZ-50

OPTIONS & ACCESSORIES

Platform Options

- Platform rotation
- Platform overload system

Power Options

- DC
- Hybrid DC/Gas

Drive Option

- Drive and set option

Coupler Options

- 2 in (5.08 cm) ball coupler
- 2.625 in (6.67 cm) ball coupler
- 2.5 in (6.35 cm) I.D. pintle ring coupler - U.S.
- Clevis coupler - U.S.

Accessories

- Ladder
- Tool tray
- Fluorescent tube caddy
- Battery charge indicator (BCI)
- Operational warning light package (flashing beacons)
- Non-marking outrigger footpads
- Spare tire
- Wheel chocks

STANDARD COMPLIANCE

- ANSI A92.2
- CAN/CSA-C255-M88
- CE Compliance
- AS 1418.10
- PB-10-611-03



TZ-50

WORKING HEIGHT	55 ft 6 in	17.09 m
HORIZONTAL REACH	29 ft 2 in	8.9 m
LIFT CAPACITY*		
ANSI, CSA	500 lbs	227 kg
CE	440 lbs	200 kg

* ANSI, CSA

* Lift capacity varies depending on options and country standards.

TRAILER MOUNTED Z-BOOMS

MODELS

TZ™-34/20

TZ™-50



A TEREX COMPANY

www.genieindustries.com

Genie United States

18340 NE 76th Street
P.O. Box 97030
Redmond, Washington 98073-9730

Telephone **(425) 881-1800**

Toll Free in USA/Canada **800-536-1800**

Fax (425) 883-3475

Genie Europe

The Maltings
Wharf Road
Grantham NG31 6BH
U.K.

Telephone **+44 (0)1476 584333**

Fax +44 (0)1476 584334

Email infoeurope@genieind.com

Distributed By: