

Specifications

MODEL TZ™-34/20

MEASUREMENTS	US	Metric
Working height*	40 ft	12.36 m
Platform height	34 ft	10.36 m
Entry height - extended	6.4 in	.16 m
Horizontal reach	18 ft 4 in	5.59 m
Clear out reach	13 ft 5 in	4.09 m
Up and over clearance	16 ft 1 in	4.90 m
A Platform length	2 ft 2.8 in	.68 m
B Platform width	3 ft 8 in	1.12 m
C Height - stowed	6 ft 4.5 in	1.94 m
D Length - stowed	18 ft .5 in	5.50 m
E Width - stowed	4 ft 9.1 in	1.45 m
F Ground clearance	9.5 in	.24 m
G Length - outrigger footprint	10 ft 8.4 in	3.26 m
H Width - outrigger footprint	11 ft 9.4 in	3.59 m

PRODUCTIVITY

Lift capacity (ANSI, CSA) - standard	500 lbs	227 kg
Lift capacity (ANSI, CSA) - rotating platform	460 lbs	209 kg
Lift capacity (CE) - standard	440 lbs	200 kg
Lift capacity (CE) - rotating platform	400 lbs	181 kg
Self leveling platform	standard	
Platform rotation option	90° mechanical	
AC power to platform	standard	
Turntable rotation	359° non-continuous	
Outrigger leveling capability	11°	
Towing speed rate	60 mph	97 km/h
Tongue weight - ANSI, CSA	315 lbs	143 kg
Surge and parking brakes	standard	
Controls	variable speed system	
Tire size	ST 205/75 R15	
Coupler	2 in (5.08 cm) hitch coupler standard	

POWER

Power source	24 V DC (four 6 V 225 Ah batteries)	
Hydraulic tank capacity	2.1 gal	8 L
Hydraulic system capacity	4.5 gal	17 L

WEIGHT**

ANSI, CSA, Australia	3,155 lbs	1,431 kg
CE	3,170 lbs	1,438 kg

STANDARDS COMPLIANCE ANSI A92.2, CSA C225, CE Compliance, AS 1418.10, PB-10-611-03

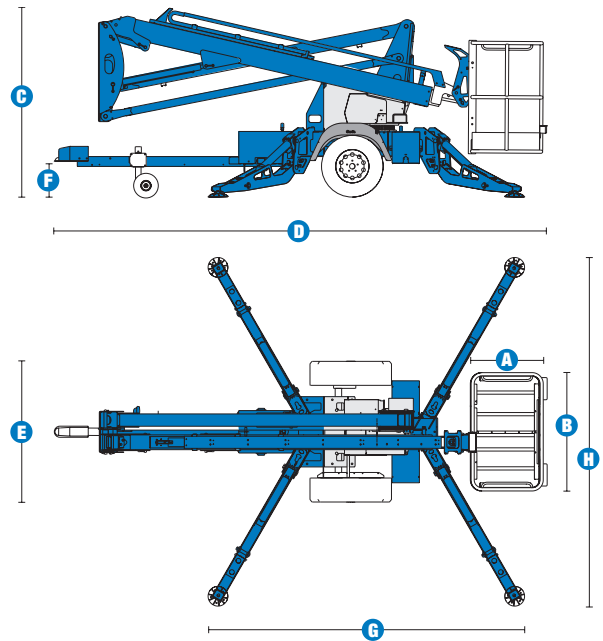

RANGE OF MOTION TZ™-34/20

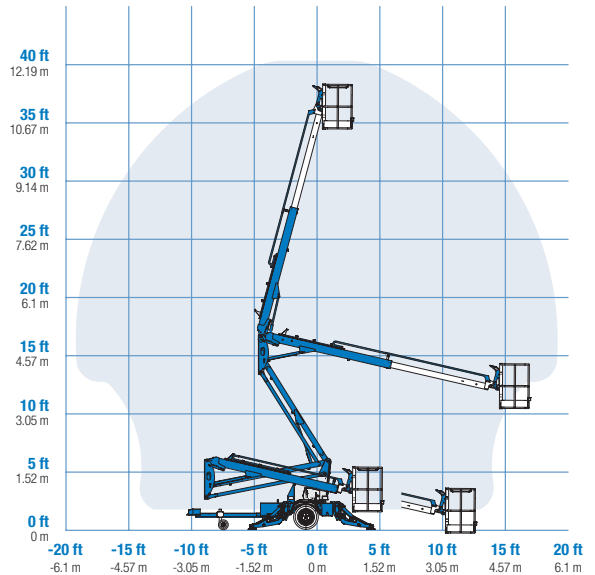

* The metric equivalent of working height adds 2 m to platform height. U.S. adds 6 ft to platform height.
 ** Weight will vary depending on options and/or country standards.

Features

EASILY CONFIGURED TO MEET YOUR NEEDS

PLATFORM OPTIONS

- Aluminum 26.8 x 44 in (.68 x 1.12 m)
- Platform overload system
- 90° mechanical platform rotation

POWER

- 24 V DC power source

COUPLER OPTIONS

- 2 in (5.08 cm) ball coupler
- 2.31 in (5.87 cm) ball coupler
- 2.5 in (6.53 cm) I.D. pintle ring coupler
- Combination hitch
- Clevis coupler

TIRE OPTIONS

- ST 205/75 R15 tires (ANSI, CSA)
- 185 R14C tires (CE)

STANDARD FEATURES

MEASUREMENTS

- 40 ft (12.36 m) working height
- 18 ft 4 in (5.59 m) horizontal reach
- Up to 500 lb (227 kg) lift capacity

PRODUCTIVITY

- Industry leading working envelope
- Extension boom
- Self-leveling platform
- 4 ft jib with 135° working range
- Variable speed control system
- AC wiring to platform
- Hydraulic outriggers
- Automatic 10° leveling system
- Outrigger interlocks
- Mechanical parking brake
- Hydraulic surge brakes
- Auxiliary pump down
- 2 in (5.08 cm) coupler lever lock
- Hitch pull bar
- Combination hitch with coupler lever lock
- Dual jockey wheels
- 359° non-continuous turntable rotation
- Easy to access batteries
- Hour meter
- Tilt alarm / sensor
- Forklift pockets
- Illuminated outrigger indicators

POWER

- 24V DC power source
(four 6V 225 Ah batteries)



OPTIONS & ACCESSORIES

PRODUCTIVITY

- Platform overload system
- 90° mechanical platform rotation
- 2 in (5.08 cm) ball coupler
- 2.31 in (5.87 cm) ball coupler
- 2.5 in (6.53 cm) I.D. pintle ring coupler
- Combination hitch
- Clevis coupler
- Wheel chocks
- Fluorescent tube caddy
- Full size spare tire
- Operational warning beacon package
- Non-marking outrigger footpads
- Battery charge indicator (BCI)
- Tool tray

Genie United States

18340 NE 76th Street
P.O. Box 97030
Redmond, Washington 98073-9730

Telephone **(425) 881-1800**
Toll Free in USA/Canada **800-536-1800**
Fax (425) 883-3475

Genie Europe

The Maltings
Wharf Road
Grantham NG31 6BH
U.K.

Telephone **+44 (0)1476 584333**
Fax +44 (0)1476 584334

Email: infoeurope@genieind.com

Distributed By:

For further information, please contact your local distributor or the Genie Industries sales office listed. Product specifications are subject to change without notice or obligation. The photographs and drawings in this brochure are for illustrative purposes only. Refer to the appropriate Operator's Manual for instructions on the proper use of this equipment. Failure to follow the appropriate Operator's Manual when using our equipment or to otherwise act irresponsibly may result in serious injury or death. Prices and specifications subject to change without notice. The only warranty applicable is the standard written warranty applicable to the particular product and sale. Genie makes no other warranty, expressed or implied. Products and services listed may be trademarks, service marks or trade-names of TEREX Corporation and/or its subsidiaries in the USA and other countries and all rights are reserved. Copyright © 2006 Genie Industries, Inc. "Genie" is a Registered Trademark of Genie Industries, Inc. in the USA and many other countries. Genie is a TEREX Company.