

OPERATION MANUAL



**MAYCO SERIES
MODEL C30HDGA
CONCRETE PUMP
(ZENITH 416 GAMMA GASOLINE ENGINE)**

Revision #1 (09/09/19)



THIS MANUAL MUST ACCOMPANY THE EQUIPMENT AT ALL TIMES.

TO PURCHASE THIS PRODUCT PLEASE CONTACT US



**Equipment Financing and
Extended Warranties Available**



**Discount-Equipment.com is your online resource for
commercial and industrial quality parts and equipment sales.**

561-964-4949

visit us on line @ www.discount-equipment.com

Select an option below to find your Equipment

Search by Manufacturer

Search by Product Type

Request a Quote


We sell worldwide for the brands: Genie, Terex, JLG, MultiQuip, Mikasa, Essick, Whiteman, Mayco, Toro Stone, Diamond Products, Generac Magnum, Airman, Haulotte, Barreto, Power Blanket, Nifty Lift, Atlas Copco, Chicago Pneumatic, Allmand, Miller Curber, Skyjack, Lull, Skytrak, Tsurumi, Husquvarna Target, Stow, Wacker, Sakai, Mi-T-M, Sullair, Basic, Dynapac, MBW, Weber, Bartell, Bennar Newman, Haulotte, Ditch Runner, Menegotti, Morrison, Contec, Buddy, Crown, Edco, Wyco, Bomag, Laymor, EZ Trench, Bil-Jax, F.S. Curtis, Gehl Pavers, Heli, Honda, ICS/PowerGrit, IHI, Partner, Imer, Clipper, MMD, Koshin, Rice, CH&E, General Equipment, Amida, Coleman, NAC, Gradall, Square Shooter, Kent, Stanley, Tamco, Toku, Hatz, Kohler, Robin, Wisconsin, Northrock, Oztec, Toker TK, Rol-Air, APT, Wylie, Ingersoll Rand / Doosan, Innovatech, Con X, Ammann, Mecalac, Makinex, Smith Surface Prep, Small Line, Wanco, Yanmar

PROPOSITION 65 WARNING



SILICOSIS/RESPIRATORY WARNINGS

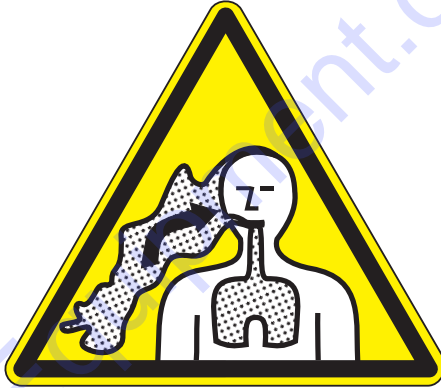
! WARNING



SILICOSIS WARNING

Grinding/cutting/drilling of masonry, concrete, metal and other materials with silica in their composition may give off dust or mists containing crystalline silica. Silica is a basic component of sand, quartz, brick clay, granite and numerous other minerals and rocks. Repeated and/or substantial inhalation of airborne crystalline silica can cause serious or fatal respiratory diseases, including silicosis. In addition, California and some other authorities have listed respirable crystalline silica as a substance known to cause cancer. When cutting such materials, always follow the respiratory precautions mentioned above.

! WARNING



RESPIRATORY HAZARDS

Grinding/cutting/drilling of masonry, concrete, metal and other materials can generate dust, mists and fumes containing chemicals known to cause serious or fatal injury or illness, such as respiratory disease, cancer, birth defects or other reproductive harm. If you are unfamiliar with the risks associated with the particular process and/or material being cut or the composition of the tool being used, review the material safety data sheet and/or consult your employer, the material manufacturer/supplier, governmental agencies such as OSHA and NIOSH and other sources on hazardous materials. California and some other authorities, for instance, have published lists of substances known to cause cancer, reproductive toxicity, or other harmful effects.

Control dust, mist and fumes at the source where possible. In this regard use good work practices and follow the recommendations of the manufacturers or suppliers, OSHA/NIOSH, and occupational and trade associations. Water should be used for dust suppression when wet cutting is feasible. When the hazards from inhalation of dust, mists and fumes cannot be eliminated, the operator and any bystanders should always wear a respirator approved by NIOSH/MSHA for the materials being used.

TABLE OF CONTENTS

C30HDGA Concrete Pump

Proposition 65 Warning	2
Silicosis/Respiratory Warnings	3
Safety Information	5–10
Specifications	11
Dimensions.....	12
Important Hand Signals.....	13
General Information.....	14–16
Components (Pump)	18–19
Components (Control Box)	20
Components (Engine).....	21
Inspection	22–24
Startup/Shutdown.....	25
Operation.....	26–30
Maintenance	31–39
Trailer Maintenance	40–41
Trailer Guidelines.....	42–55
Troubleshooting	56–57
Engine Fault Codes	58–63
Appendix — Concrete Mix Information.....	64–66
Wiring Diagram (Wiring Harness).....	67
Electrical Component Locator	68–69

NOTICE

Specifications are subject to change without notice.

SAFETY INFORMATION

Do not operate or service the equipment before reading the entire manual. Safety precautions should be followed at all times when operating this equipment. Failure to read and understand the safety messages and operating instructions could result in injury to yourself and others.



SAFETY MESSAGES

The four safety messages shown below will inform you about potential hazards that could injure you or others. The safety messages specifically address the level of exposure to the operator and are preceded by one of four words: **DANGER**, **WARNING**, **CAUTION** or **NOTICE**.

SAFETY SYMBOLS

DANGER
Indicates a hazardous situation which, if not avoided, WILL result in DEATH or SERIOUS INJURY .
WARNING
Indicates a hazardous situation which, if not avoided, COULD result in DEATH or SERIOUS INJURY .
CAUTION
Indicates a hazardous situation which, if not avoided, COULD result in MINOR or MODERATE INJURY .
NOTICE
Addresses practices not related to personal injury.

Potential hazards associated with the operation of this equipment will be referenced with hazard symbols which may appear throughout this manual in conjunction with safety messages.

Symbol	Safety Hazard
	Lethal Exhaust Gas Hazards
	Explosive Fuel Hazards
	Burn Hazards
	Respiratory Hazards
	Eye and Hearing Hazards
	Accidental Starting Hazards
	Pressure Hazards
	Hydraulic Fluid Hazards
	Rotating Parts Hazards

SAFETY INFORMATION

GENERAL SAFETY

CAUTION

- **NEVER** operate this equipment without proper protective clothing, shatterproof glasses, respiratory protection, hearing protection, steel-toed boots and other protective devices required by the job or city and state regulations.

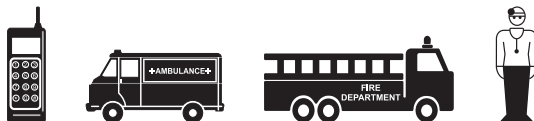


- **NEVER** operate this equipment when not feeling well due to fatigue, illness or when on medication.
- **NEVER** operate this equipment under the influence of drugs or alcohol.



NOTICE

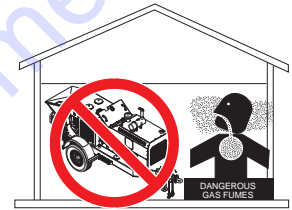
- This equipment should only be operated by trained and qualified personnel 18 years of age and older.
- Whenever necessary, replace nameplate, operation and safety decals when they become difficult read.
- Manufacturer does not assume responsibility for any accident due to equipment modifications. Unauthorized equipment modification will void all warranties.
- **NEVER** use accessories or attachments that are not recommended by Multiquip for this equipment. Damage to the equipment and/or injury to user may result.
- **ALWAYS** know the location of the nearest fire extinguisher.
- **ALWAYS** know the location of the nearest first aid kit.
- **ALWAYS** know the location of the nearest phone or **keep a phone on the job site**. Also, know the phone numbers of the nearest ambulance, doctor and fire department. This information will be invaluable in the case of an emergency.



PUMP SAFETY

DANGER

- **NEVER** pump volatile, explosive, flammable or low flash point fluids. These fluids could ignite or explode.
- The engine fuel exhaust gases contain poisonous carbon monoxide. This gas is colorless and odorless, and can cause **death** if inhaled.
- The engine of this equipment requires an adequate free flow of cooling air. **NEVER** operate this equipment in any enclosed or narrow area where free flow of the air is restricted. If the air flow is restricted it will cause injury to people and property and serious damage to the equipment or engine.
- **NEVER** operate the equipment in an explosive atmosphere or near combustible materials. An explosion or fire could result causing **severe bodily harm or even death**.



WARNING

- **NEVER** pump corrosive chemicals or water containing toxic substances. These fluids could create serious health and environmental hazards. Contact local authorities for assistance.
- **NEVER** disconnect any **emergency or safety devices**. These devices are intended for operator safety. Disconnection of these devices can cause **severe injury, bodily harm or even death**. Disconnection of any of these devices will void all warranties.

SAFETY INFORMATION

CAUTION

- **NEVER** lubricate components or attempt service on a running machine.
- **NEVER** block or restrict flow from discharge hose. Remove kinks from discharge line before starting pump. Operation with a blocked discharge line can cause clutch to fail.
- **DO NOT** operate this equipment unless the hopper grate, guards and safety devices are attached and in place.
- **CAUTION** must be exercised while servicing this equipment. Rotating and moving parts can cause injury if contacted.
- Keep hands out of the hopper when the engine is running.

NOTICE

- In winter drain water from the lubrication box to prevent freezing.
- **ALWAYS** be sure the operator is familiar with proper safety precautions and operation techniques before using pump.
- Keep all ***inexperienced*** and ***unauthorized*** people away from the equipment at all times.
- Before start-up, check the hopper and remove all foreign matter and debris.
- **DO NOT** use worn or damaged hose couplings, inspect all hoses and couplings for wear. Replace any worn or defective hoses or couplings immediately.
- Unauthorized equipment modifications will void all warranties.
- Check all fasteners periodically for tightness. Also check towing tongue bolt, lock nut and wheel lug nuts for wear.
- Test the pump's ***emergency stop*** switch. The purpose of this test is to shut down the engine in the event of an emergency.
- Multiquip strongly encourages the operator to take the safety training courses offered by the American Concrete Pumping Association (www.concretepumpers.com).

- Refer to the Engine Owner's Manual for engine technical questions or information recommended by Multiquip for this equipment. Damage to the equipment and or injury to user may result.
- **ALWAYS** remove the ignition key when leaving the pump unattended.
- **ALWAYS** block the wheels on the unit when using on a slope.
- **ALWAYS** use properly rated hoses and clamps — 1,500 PSI or higher.
- **ALWAYS** allow the pump a proper amount of time to cool before servicing.
- **ALWAYS** keep the machine in proper running condition.
- **ALWAYS** ensure pump is on level ground before use.
- Fix damage to machine and replace any broken parts immediately.
- **ALWAYS** store equipment properly when it is not being used. Equipment should be stored in a clean, dry location out of the reach of children and unauthorized personnel.

ENGINE SAFETY

WARNING

- **DO NOT** place hands or fingers inside engine compartment when engine is running.
- **NEVER** operate the engine with heat shields or guards removed.
- **DO NOT** remove the engine oil drain plug while the engine is hot. Hot oil will gush out of the oil tank and severely scald any persons in the general area of the pump.



CAUTION

- **NEVER** touch the hot exhaust manifold, muffler or cylinder. Allow these parts to cool before servicing equipment.



SAFETY INFORMATION

NOTICE

- **NEVER** run engine without an air filter or with a dirty air filter. Severe engine damage may occur. Service air filter frequently to prevent engine malfunction.
- **NEVER** tamper with the factory settings of the engine or engine governor. Damage to the engine or equipment can result if operating in speed ranges above the maximum allowable.



FUEL SAFETY

DANGER

- **DO NOT** start the engine near spilled fuel or combustible fluids. Fuel is extremely flammable and its vapors can cause an explosion if ignited.
- **ALWAYS** refuel in a well-ventilated area, away from sparks and open flames.
- **ALWAYS** use extreme caution when working with **flammable** liquids.
- **DO NOT** fill the fuel tank while the engine is running or hot.
- **DO NOT** overfill tank, since spilled fuel could ignite if it comes into contact with hot engine parts or sparks from the ignition system.
- Store fuel in appropriate containers, in well-ventilated areas and away from sparks and flames.
- **NEVER** use fuel as a cleaning agent.
- **DO NOT** smoke around or near the equipment. Fire or explosion could result from fuel vapors or if fuel is spilled on a hot engine.
- To prevent leakage, tighten the fuel cap until it clicks.
- Slowly open fuel cap to release pressure.



BATTERY SAFETY

DANGER

- **DO NOT** drop the battery. There is a possibility that the battery will explode.
- **DO NOT** expose the battery to open flames, sparks, cigarettes, etc. The battery contains combustible gases and liquids. If these gases and liquids come into contact with a flame or spark, an explosion could occur.



WARNING

- **ALWAYS** wear safety glasses when handling the battery to avoid eye irritation. The battery contains acids that can cause injury to the eyes and skin.
- Use well-insulated gloves when picking up the battery.
- **ALWAYS** keep the battery charged. If the battery is not charged, combustible gas will build up.
- **DO NOT** charge battery if frozen. Battery can explode. When frozen, warm the battery to at least 61°F (16°C).
- **ALWAYS** recharge the battery in a well-ventilated environment to avoid the risk of a dangerous concentration of combustible gases.
- If the battery liquid (dilute sulfuric acid) comes into contact with **clothing or skin**, rinse skin or clothing immediately with plenty of water.
- If the battery liquid (dilute sulfuric acid) comes into contact with **eyes**, rinse eyes immediately with plenty of water and contact the nearest doctor or hospital to seek medical attention.



CAUTION

- **ALWAYS** disconnect the **NEGATIVE** battery terminal before performing service on the equipment.
- **ALWAYS** keep battery cables in good working condition. Repair or replace all worn cables.

SAFETY INFORMATION

TRANSPORTING SAFETY

CAUTION

- **NEVER** allow any person or animal to stand underneath the equipment while lifting.

NOTICE

- Before lifting, make sure that the equipment parts are not damaged and screws are not loose or missing.
- **ALWAYS** make sure forklift forks are inserted into pockets (if applicable) as far as possible when lifting the pump.
- **ALWAYS** shut down engine before transporting.
- **NEVER** lift the equipment while the engine is running.
- Tighten fuel tank cap securely to prevent fuel from spilling.
- Use one-point suspension hook and lift straight upwards.
- **DO NOT** lift machine to unnecessary heights.
- **ALWAYS** tie down equipment during transport by securing the equipment with straps, rope or chains.

TOWING SAFETY

CAUTION

- Check with your local county or state safety towing regulations, in addition to meeting **Department of Transportation (DOT) Safety Towing Regulations**, before towing your pump. 
- In order to reduce the possibility of an accident while transporting the pump on public roads, **ALWAYS** make sure the trailer that supports the pump and the towing vehicle are mechanically sound and in good operating condition.
- **ALWAYS** shut down engine before towing.
- Make sure the hitch and coupling of the towing vehicle are rated equal to or greater than the trailer gross vehicle weight rating.
- **ALWAYS** inspect the hitch and coupling for wear. **NEVER** tow a trailer with defective hitches, couplings, chains, etc.

- Check the tire air pressure on both towing vehicle and trailer. **Trailer tires should be inflated to 80 psi cold.** Also check the tire tread wear on both vehicles.
- **ALWAYS** make sure the trailer is equipped with a **safety chain**.
- **ALWAYS** properly attach trailer's safety chains to towing vehicle.
- **ALWAYS** make sure the vehicle and trailer directional, backup, brake and trailer lights are connected and working properly.
- DOT requirements include the following:
 - Connect and test electric brake operation.
 - Secure portable power cables in cable tray with tie wraps.
- The maximum speed for highway towing is **55 MPH** unless posted otherwise. Recommended off-road towing is not to exceed **15 MPH** or less depending on type of terrain.
- Avoid sudden stops and starts. This can cause skidding or jack-knifing. Smooth, gradual starts and stops will improve towing.
- Avoid sharp turns to prevent rolling.
- Trailer should be adjusted to a level position at all times when towing.
- Raise and lock trailer wheel stand in up position when towing.
- Place **chock blocks** underneath wheels to prevent **rolling** while parked.
- Place **support blocks** underneath the trailer's bumper to prevent **tipping** while parked.
- Use the trailer's swivel jack to adjust the trailer height to a level position while parked.

SAFETY INFORMATION

ENVIRONMENTAL SAFETY/DECOMMISSIONING

NOTICE

Decommissioning is a controlled process used to safely retire a piece of equipment that is no longer serviceable. If the equipment poses an unacceptable and unrepairable safety risk due to wear or damage, or is no longer cost effective to maintain (beyond life-cycle reliability) and is to be decommissioned (demolition and dismantlement), be sure to follow the rules below.

- **DO NOT** pour waste or oil directly onto the ground, down a drain or into any water source.
- Contact your country's Department of Public Works or recycling agency in your area and arrange for proper disposal of any electrical components, waste or oil associated with this equipment.
- When the life cycle of this equipment is over, remove battery and bring to appropriate facility for lead reclamation. Use safety precautions when handling batteries that contain sulfuric acid.
- When the life cycle of this equipment is over, it is recommended that the frame and all other metal parts be sent to a recycling center.



Metal recycling involves the collection of metal from discarded products and its transformation into raw materials to use in manufacturing a new product.

Recyclers and manufacturers alike promote the process of recycling metal. Using a metal recycling center promotes energy cost savings.

EMISSIONS INFORMATION

NOTICE

The diesel engine used in this equipment has been designed to reduce harmful levels of carbon monoxide (CO), hydrocarbons (HC) and nitrogen oxides (NOx) contained in diesel exhaust emissions.

This engine has been certified to meet US EPA evaporative emissions requirements in the installed configuration.

Attempting to modify or make adjustments to the engine emission system by unauthorized personnel without proper training could damage the equipment or create an unsafe condition.

Additionally, modifying the fuel system may adversely affect evaporative emissions, resulting in fines or other penalties.

Emission Control Label

The emission control label is an integral part of the emission system and is strictly controlled by regulations.

The label must remain with the engine for its entire life.

If a replacement emission label is needed, please contact your authorized engine distributor.

SPECIFICATIONS

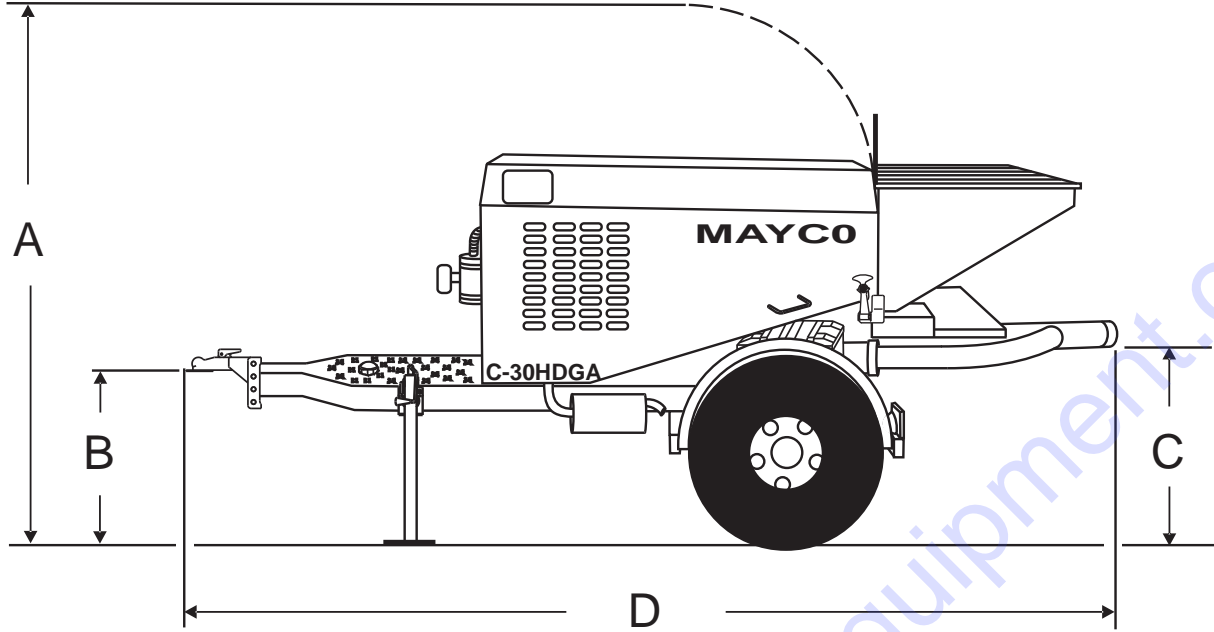
Table 1. C30HDGA Pump Specifications

Pump Type	Reciprocating Piston
Pumping Rate	Up to 25 cu. yds. per hour*
Vertical Pumping Height	Up to 150 ft. (45.73 m)
Horizontal Pumping Distance	400 - 500 ft. (122 - 152 m)*
Max. Concrete Piston Face Pressure	500 PSI
Maximum Aggregate Size	1/2 in. minus (12.7 mm)
Hopper Capacity	6 cu. ft. etc.
Material Hose	2" or 2-1/2" (50.8 or 63.5 mm)"
Weight	2,950 lbs. (1,338 Kg)
Lube oil Box	7 Gallons (26.5 Liters)
Remote Control	125 ft. cable Standard
Tire Size	7.35" x 14" (187 x 356 mm)
* Volume output will vary depending on mix design, slump, line size used and job site conditions.	

Table 2. Engine Specifications

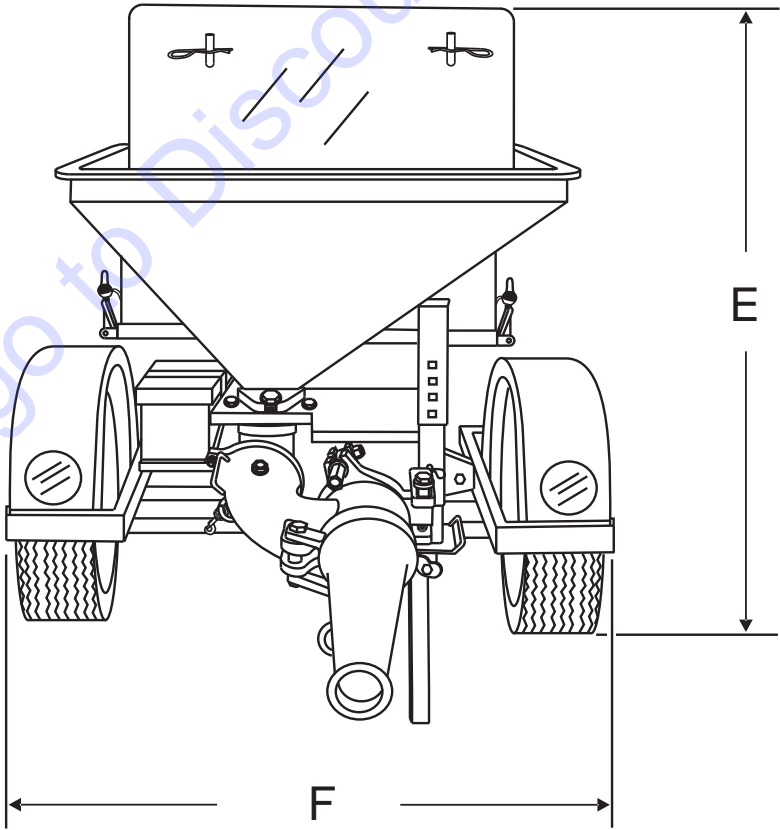
Model	ZENITH 416 GAMMA
Type	4 stroke, overhead valve, single cylinder horizontal shaft gasoline engine
Bore x Stroke	3.032 in. x 3.362 in. (77 mm x 85.4 mm)
Compression Ratio	11:1
Displacement	97.1 cu. (1,591 cc)
Continuous Output	45 H.P. @2700 R.P.M.
Fuel Tank Capacity	Approx. 11 U.S. Gallons (42 liters)
Fuel Type	Unleaded Gasoline
Lube Oil Capacity	3.49 qts. (3.3 liters)
Engine Speed Full Load	2650 rpm ±100 (No Load 2750 rpm +/- 50) (Load 2750 rpm +/- 100)
Engine Speed Full Idle	950 rpm ±100
Air Cleaner	Air Horn Type
Engine Lubrication	SAE 10W-30 (Oil Grade) SG or SF (Service Class)
Starting Method	Electric Start
Spark Plug	B4ES
Spark Plug Gap	0.8 - 0.9 in (0.031-0.035 mm).
Dimension (L x W x H)	20.10 x 22.50 x 25.80 in. (509.9 x 527.5 x 654.5 mm)
Dry Net Weight	178 lbs (126.3 Kg.)

DIMENSIONS



145 IN. (3.68 M) DISCHARGE
CONE IN TRAVEL
POSITION

Table 3. Pump Dimensions	
Reference Letter	Dimensions in. (mm)
A	76 (1930)
B	14.5 (368)
C	16 (406)
D	161 (4089)
E	63.5 (1612)
F	59.5 (1511)



IMPORTANT HAND SIGNALS

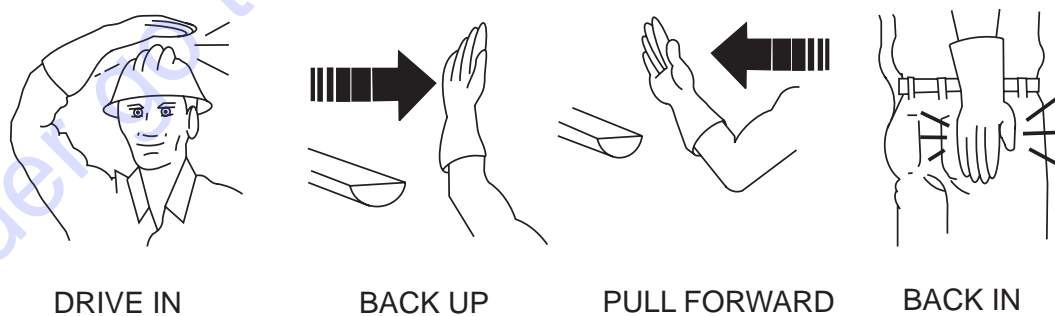
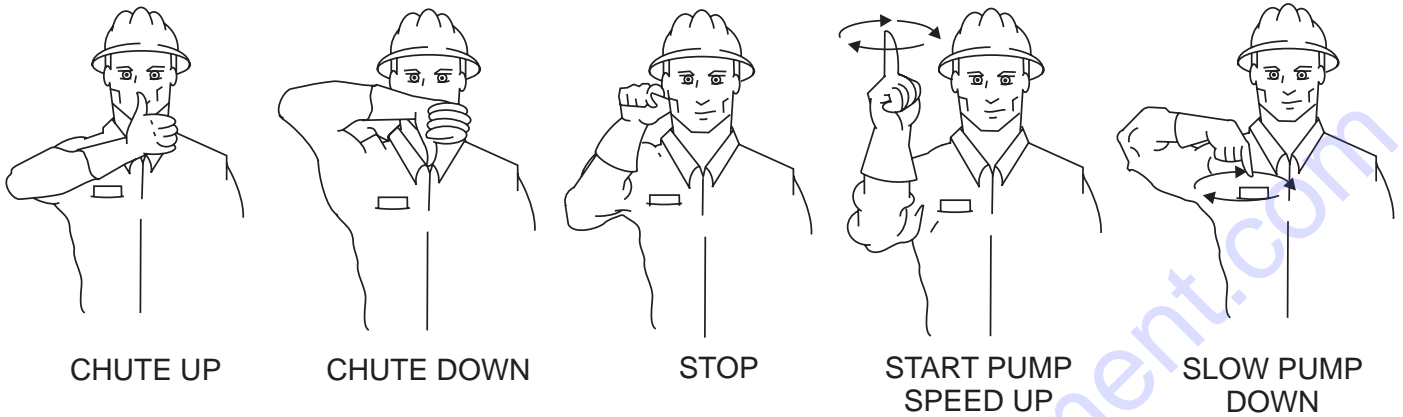


Figure 1. Operation Hand Signals

GENERAL INFORMATION

The following operating principles and operating suggestions should prove helpful in the successful operation of your concrete pump. Your new “small line” concrete pump has been designed to give you many years of service when operated properly. A study of the following paragraphs is important to the successful operation of your new Direct-flow Concrete Placer.

All concrete pumps require a high level of operator skill and more frequent service than most of the other construction equipment. The highly abrasive nature of concrete under pressure makes it extremely important that expendable wear components be inspected at regular intervals between jobs to prevent having to replace these items during a pour.

Experience has proved that inconsistency of batched concrete mixes and frequent moving of the line requires the operator to be readily available at all times during pumping to stop the pump and prevent abuse to the unit which may occur if unexpected blockages develop.

PUMP MIX GUIDELINES

When ordering concrete, be certain to advise the concrete supplier that you require a “pump mix”. The Direct-flow manifold will pump a wide variety of materials, but certain basic principles must be followed to assure successful pumping, as follows:

Generally speaking, the washed concrete sand and #4 aggregate (pea gravel) should conform to A.S.T.M. standards in regard to sieve analysis. Sands in some areas are washed clean of the #100 and #200 mesh fines, which results in separation and jamming in the manifold while pumping under pressure.

If this condition develops, check with your concrete suppliers engineers and get their recommendations for supplementing the lack of the fines. The use of locally accepted ad-mixes may be required. (For example, Pozzoloth, Bentonite Clay, Plastiments, etc.) When properly prescribed, additives form the plastic paste sometimes necessary to hold the cement and aggregate together.

NOTICE

If jamming conditions in the pump or hose occur for any reason at all, do not attempt to use more power to correct the condition.

Determine the cause of jamming, correct it and resume pumping. Trying to force material through under jammed conditions may result in damage to the drive system, thus voiding any warranty services

As a general rule, the use of approximately six sacks of cement, 70% washed concrete sand and 30% #4 pea gravel per yard of concrete will result in a pumpable mix. The ideal nature of sand and rock in certain areas may permit you to increase the percentage of rock or adjust the mix considerably to meet the job requirements. When possible, you may experiment with various mixes in your area to determine the degree of versatility of the Direct-flow Pump.

Uniform gradation of the washed concrete sand and the 1/2” minus aggregate along with sufficient cement content and water are important to a successful pump operation.

A recommended pumpable mix design would be 70% sand and 30% aggregate-cement content to be a minimum of 6 sacks. (564 lbs.)

NOTICE

Your local sand and rock engineers will give you the S.S.D. weights of sand and rock required in your local area which will yield one cubic yard per the above recommendation.

Sample Design Mix - 3000 Psi 3/8 in. Slump 4- 5 in.

Type II Cement	6.49 sack/cu. yd	611 lbs.
Sand	Sat. Surf. Dry	2000 lbs.
#4 Gravel	Sat. Surf. Dry	864 lbs.
#3 Gravel	Sat. Surf. Dry	0 lbs.
Water	48 Gallons	400 lbs.
	Total Weight	3,906 lbs
Admixture WRDA-79		26 oz.
Water		7.40 gal/sack

Test laboratory data has proven in many areas that the above mix guidelines have produced concrete rated at 3000 psi (28 day test) and upwards of 5000 psi with an increase in cement.

In some areas where the gradation of sand and rock is ideal and sufficient cement is used along with admixtures, the Mayco small line concrete pump will handle up to a 50-50 ratio of sand and rock.

When the mix is designed for wet gunning applications, it is normal to increase the cement (up to 7.5 or 8 sacks) and change the sand to rock ratio to 85% sand and 15% rock.

The Mayco concrete pump will valve efficiently when using cellular-foam concrete mixes upwards of 70 lbs. per cubic foot wet density. Below 70 lbs. materials (roof decks), the valving becomes inefficient.

GENERAL INFORMATION

HOW IT WORKS

The C30HDGA concrete pump has one main pumping piston which is valved by means of two ball checks. (A inlet, and B outlet.)

The secondary piston is used as a compensator piston to smooth out the pulsations of a single piston action. Note: The compensator will not start operating until material is pumped into the line and back pressure develops.

The compensator spring, which is installed on the compensator piston rod, deflects with each piston stroke. This “spring cushion”, in conjunction with the cam profile, produces an uninterrupted smooth flow of material under average pumping conditions.

The pumping cylinder (Figure 2) retracts drawing the material past the ball (A) and filling the cylinder. The compensator piston is pumping the material out to the nozzle and causing ball (B) to seat preventing the material from returning to the pumping cylinder intake.

An automatic, centrifugal clutch is installed to engage and disengage the pumping action without stopping or starting the engine. The centrifugal clutch is set at 1100 R.P.M. The engine idle speed is approximately 900 R.P.M.; therefore, the clutch is completely disengaged at idle. The throttle settings while pumping should always maintain an engine R.P.M. high enough to prevent the clutch from slipping and burning the clutch lining.

The return spring which is installed on the rocker arm, is installed to eliminate shock and stress between the cam roller and the cam weldment when the pump is in operation. If the return spring is removed or replaced for any reason, maintain the backing plate dimension of 3” as shown on Figure 3, to produce the proper pre-loading of the spring for a smooth performance.

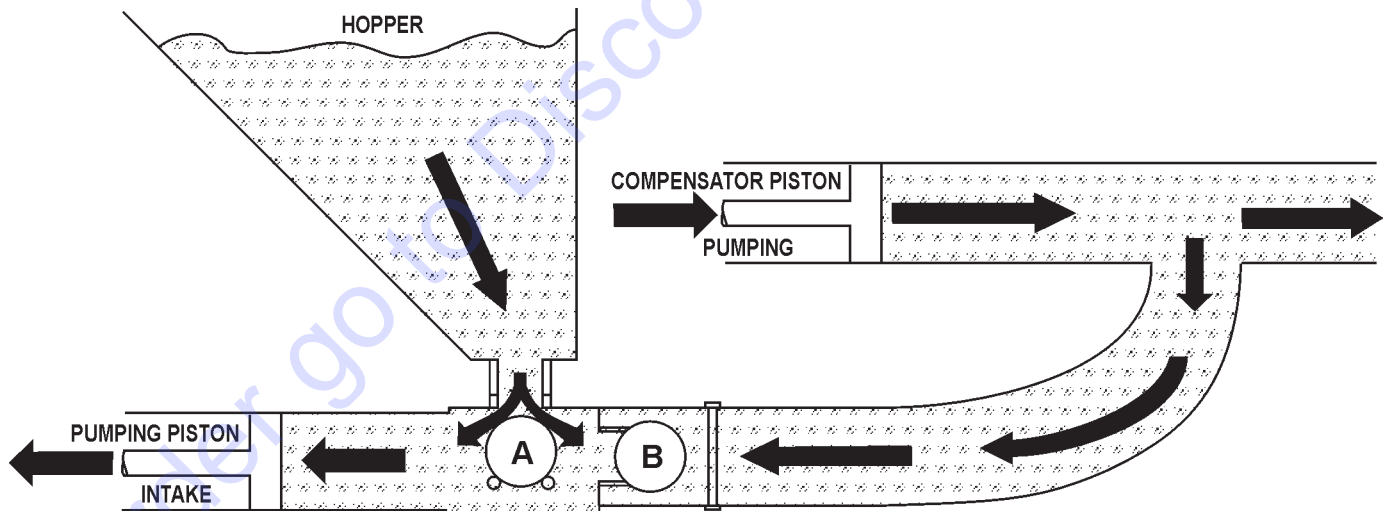


Figure 2. Pumping Cylinder

GENERAL INFORMATION

The pumping piston (Figure 3) is forcing the material past ball (B) and out to the nozzle, also seating ball A so that the material will not flow back to the hopper. This action also fills the compensator piston for the next stroke.

Figure 4 shows the relationship between the return spring, the compensator spring and the rocker arm to maintain a smooth performance. DO NOT tighten the bolt (Item 1) completely, the rod end must be able to move.

The return spring is installed to eliminate shock and stress between the cam roller and the cam weldment when the pump is in operation. If the return spring is removed or replaced for any reason, maintain the backing plate dimension (3-inches) as shown to produce proper pre-loading of the spring for a smooth performance.

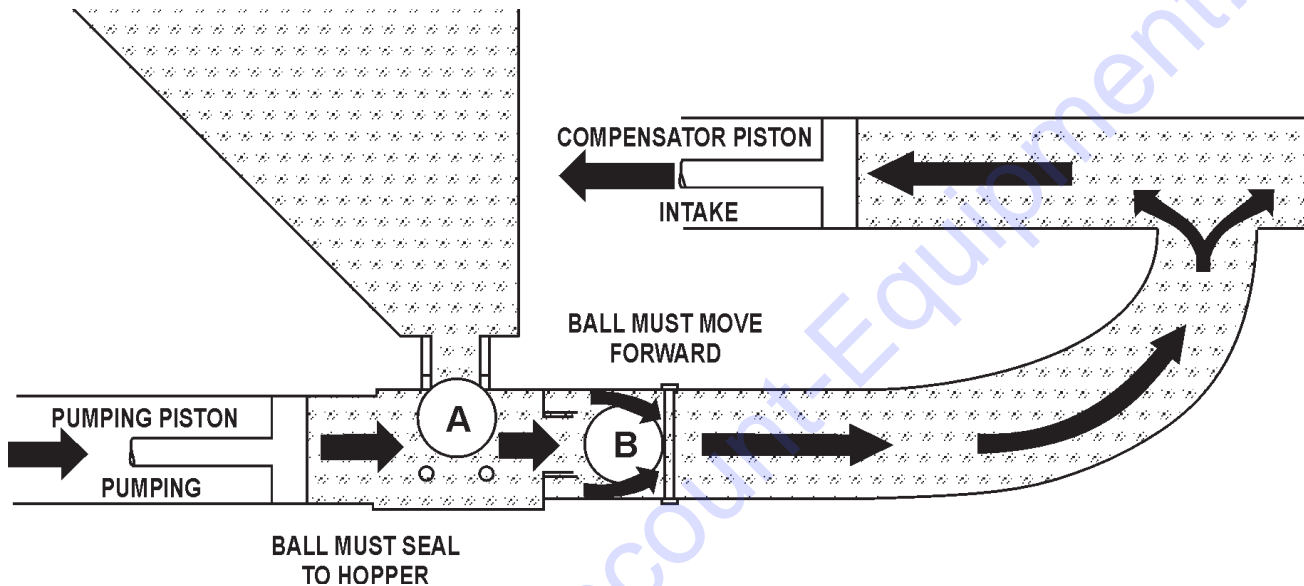


Figure 3. Pumping Pistons

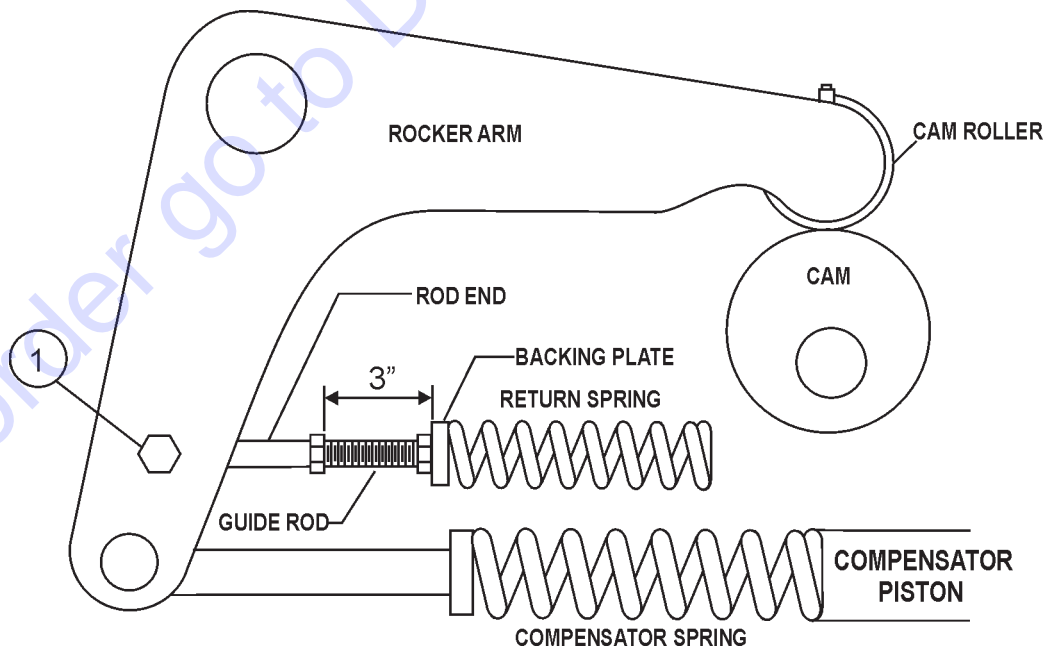


Figure 4. Return Spring, Compensator Spring and Rocker Arm Interaction

COMPONENTS (PUMP)

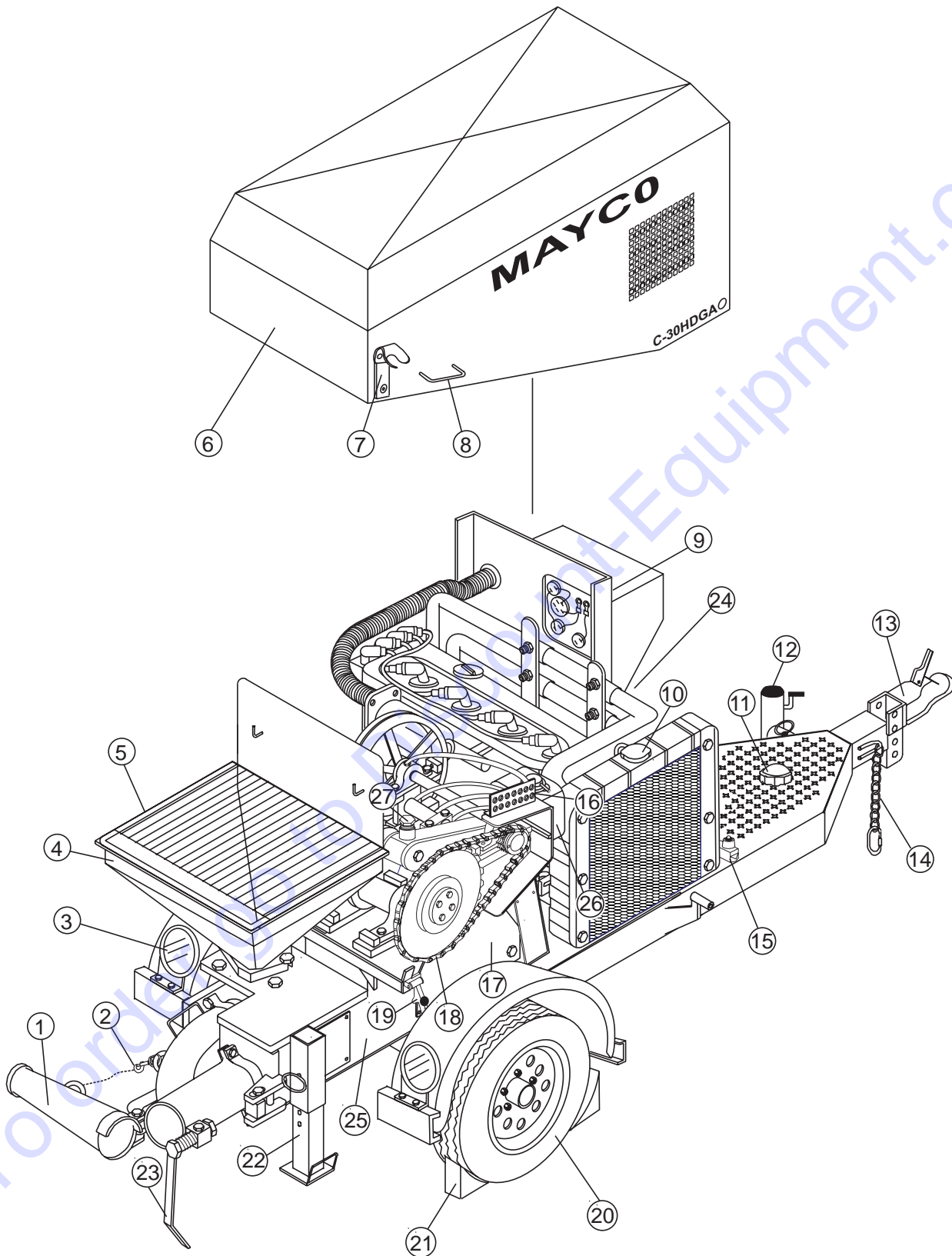


Figure 5. Pump Components

COMPONENTS (PUMP)

Figure 5 illustrates the location of the major components for the C30HDGA Concrete Pump. The function of each component is described below:

1. **Discharge Cone** — Connect 3" elbow to this discharge port, then connect 3" x 2" reducer to elbow.
2. **Discharge Cone Safety Latch** — When towing of the pump is required, **ALWAYS** secure the discharge cone to latch located on the manifold.
3. **Rear Running Lights** — **ALWAYS** check and make sure both the right and left running lights are functioning correctly before towing the pump.
4. **Hopper** — Concrete from a Redi-Mix truck is poured into this hopper. The hopper can hold 6.0 cu. ft of concrete. **NEVER** put hands or any other parts of you body into the hopper.
5. **Safety Grill** — The safety grill should be locked at all times when the pump is being towed. Under normal working conditions, raise and place the safety grill on the support hooks which are located on splash guard.
6. **Compartment Hood** — **NEVER** operate the pump with the hood removed. Installed on the pump frame is a safety interlock device which will disable high speed if the hood is removed or in the up position (open).
7. **Hood Fastener** — When the hood is in the down position, secure the rubber latch to this fastener.
8. **Hood Lift Handle** — Grip this handle, pull upward then back to raise the compartment hood.
9. **Control Box** — Contains the mechanical and electrical components required to run the pump. Below is a list of those components:
 - Throttle Control Switch
 - Pumping Control
 - Check Engine Indicator
 - Hood Open Indicator
 - Engine Hour Meter
 - Ignition Switch
 - Remote Connector
10. **Radiator/Cap** — Fill with a water/anti-freeze type solution as recommended in the maintenance section of this manual. **ALWAYS** make sure that the radiator is filled to the proper operating level before starting the engine.
11. **Fuel Tank/Cap** — Fill with unleaded fuel. Fuel tank (cell) holds approximately 11 gallons (42 liters). **DO NOT** top off fuel. Wipe up any spilled fuel immediately.
12. **Tow End Jack Stand** — Use this jack stand to level and support the pump.
13. **Tow Hitch Coupler** — Requires a 2-inch ball hitch or a 3-inch pintle. Capable of towing 5,000 lbs.
14. **Safety Chain** — **ALWAYS** attach safety chain to the towing vehicle. **NEVER** tow the pump with the safety chain unattached.
15. **Engine Safety Device** — This device will return the engine speed to idle if the compartment hood is in the up position. The compartment hood **must** be in the down position for the pump to operate at high rpm's.
16. **Grease Port Console** — This console allows for the remote lubrication of components on the pump.
17. **Access Door** — There are four access doors on the pump. Remove these door to gain access to drive and piston assemblies when maintenance is required.
18. **Drive Chain** — Keep this chain properly lubricated and aligned at all times. Lubricate this chain as specified in the maintenance section of this maintenance.
19. **Steel Latch** — Secure this rubber latch to the hood fastener whenever the pump is in use or being towed.
20. **Tires Ply** — The tire ply (layers) number is rated in letters; This trailer uses 4-ply tires.
21. **Chock Blocks** — Place these blocks (not included as part of your concrete pump package) under each trailer wheel to prevent rolling.
22. **Pump End Jack Stand** — Use this jack stand to level and support the pump.
23. **Discharge Cone Release Lever** — secures the discharge cone to the "Y" manifold; also relieves manifold pressure.
24. **Documentation Box** — Contains engine and pump operation, parts and maintenance information.
25. **Lubrication Box** — This box is empty when shipped from the factory. Please fill with 7 gallons (26.5 liters) of SAE motor oil for first time use. Also check the dual clean-out point on bottom of lubrication box for a secure tight fit.
26. **Overflow Bottle** — Fill with coolant. Maintain coolant at proper level. See fluid level markings on side of bottle.
27. **Cam Bearing** — Felt ring must be periodically lubricated applying 4 or 5 drops of 30 wt. motor oil until the felt ring is moist.

COMPONENTS (CONTROL BOX)

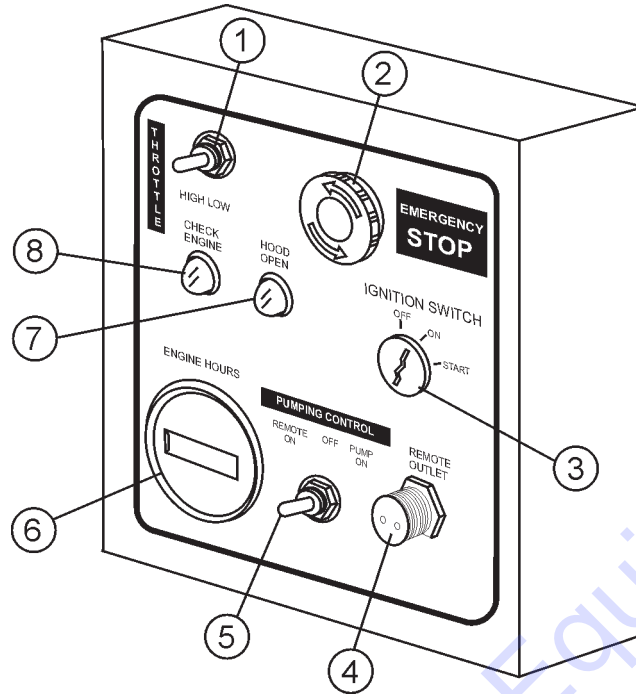


Figure 6. Pump Control Box Components

Figure 6 illustrates the location of the major components for the C30HDGA Control Box. The function of each component is described below:

1. **Throttle Control Switch** — This is a variable speed type control. Holding the control switch to the left increases the engine speed. To place the engine at IDLE speed, hold the control switch to the right and let the engine run for 3-5 minutes.
2. **Emergency Stop Button** — In the event of an emergency or to shutdown the engine, push RED emergency stop button inward. This will stop the engine. To restart engine, emergency stop button must be released from the stop position. Simply pull back on the emergency stop button to release.
3. **Ignition Switch** — Insert the ignition key here to start the engine. Turn the key clockwise to the ON position, then continue turning clockwise to the START position and release. To stop the engine turn the key fully counter-clockwise to the STOP position.
4. **Remote Control Input Connector** — Insert the remote control input cable into this connector.
5. **Pumping Control Switch** — This 3-position switch controls the pumping of the pump. The left most position is for use with the remote control unit, the center position is for off (prevents pumping), and the right most position is for normal pump operation.
6. **Hourmeter** — Display's the number of hours the pump has been in use.
7. **Hood Open Lamp** — When lit (red) indicates that the hood has been raised (open) during pumping operation. This condition will force the engine into idle mode.
8. **Check Engine Lamp** — When lit (yellow) indicates that an engine error as occurred. See Table 7 for a listing of engine diagnostic error codes.

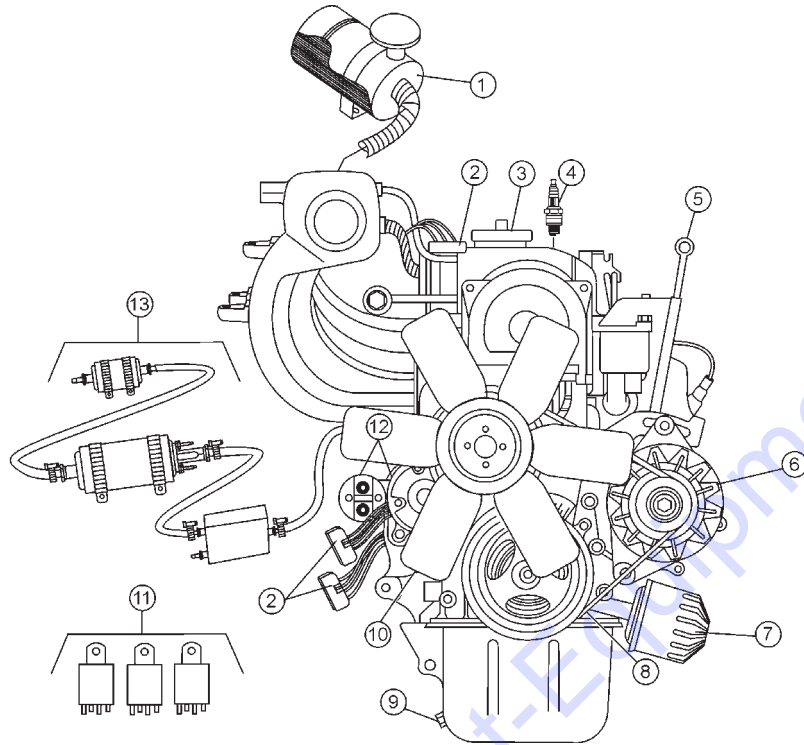


Figure 7. Zenith 416 Gamma Engine Components

Figure 7 illustrates the location of the basic components for the Zenith 416 Gamma gasoline engine. The function of each component is described below:

1. **Air Filter** — Prevents dirt and other debris from entering the fuel system. Remove wing-nut on top of air filter canister to gain access to filter element. Replace only with manufacturer's recommended type air filter.
2. **Fuse Connector** — Contains fuses for electrical system. Replace with only recommended type fuses.
3. **Oil Filler Port Cap** — Remove this cap to add engine oil to the crankcase. Fill with recommended type oil as specified.
4. **Spark Plug** — Provides spark to the ignition system. Set spark plug gap to 0.6 - 0.7 mm (0.028 - 0.031 inch). Clean spark plug once a week.
5. **Dipstick** — Remove this dipstick to determine if engine oil is low. Maintain oil level at the "H" marking on the dipstick. NEVER run engine with low oil.
6. **Alternator** — Provides power to the electrical system. Replace only with manufacturer's recommended type alternator.
7. **Oil Filter** — Replace this oil filter as recommended in the maintenance section of this manual.
8. **Fan V-Belt** — ALWAYS make sure that V-belt is properly tensioned. A loose or defective V-belt can adversely affect the performance of the pump.
9. **Crankcase Drain Plug** — Remove this plug to drain engine oil from the crankcase. Replace with recommended engine oil as specified in the maintenance section of this manual.
10. **Cooling Fan Blades** — Make sure that the blades of the cooling fan are not bent or broken. A damaged fan blade can cause the engine to run hot and overheat.
11. **Control Relays** — Includes a main relay, fuel pump relay and starter relay. Replace only with recommended type relays.
12. **Starter Motor/Solenoid** — NEVER allow concrete or any foreign debris to come in contact with the starter motor/solenoid.
13. **Fuel Filter/Fuel Pump/Fuel Regulator** — Replace or clean the fuel filter, fuel pump or fuel regulator as specified in the maintenance section of this manual.

WARNING



NEVER operate the pump in a confined area or enclosed area structure that does not provide ample free flow of air.



ALWAYS wear approved eye and hearing protection when operating the pump.



NEVER operate the engine with the engine hood removed. The possibility exists of hands, long hair, or clothing becoming entangled with the V-belt, causing injury and bodily harm.

NEVER place hands or feet inside the hopper. **ALWAYS** shut down the engine before performing any kind of maintenance service on the pump.

FUEL CHECK

DANGER

Handle fuel safely. Motor fuels are **highly flammable** and can be dangerous if mishandled. **NEVER** smoke while refueling. **NEVER** attempt to refuel the pump when the engine is hot or running.

DANGER



Gasoline is **extremely flammable** and its vapors can cause an **explosion** if ignited. **NEVER** start the engine near spilled fuel or combustible fluids. **NEVER** fill the fuel tank while the engine is running or hot.

DO NOT overfill the tank, as spilled fuel can ignite if it comes into contact with hot engine parts or sparks from the ignition system. Store fuel in approved containers, in well-ventilated areas, away from sparks and flames. **NEVER** use fuel as a cleaning agent.

BEFORE STARTING



1. Read the safety instructions at the beginning of this manual.
2. Remove any dirt and dust that might have accumulated around the engine cooling air inlet, fuel injection system.
3. Check the air filter for dirt and dust. If air filter is dirty, replace air filter with a new one as required.
4. Check fuel injection system for external dirt and dust. Clean with dry compressed air.
5. Check fastening nuts and bolts for tightness.
6. Connect Battery.
7. Make sure hopper is free of dirt and foreign debris.
8. Make sure radiator is filled with proper amount of anti-freeze water solution (50/50).
9. Make sure all hose lines are in good condition and are working properly.

1. Remove the gasoline cap located on top of fuel tank.
2. Handle Fuel in a safety container. If the container does not have a spout, use a funnel.
3. Visually inspect to see if fuel level is low. If fuel is low, replenish with unleaded fuel. When refueling, be sure to use a strainer for filtration. **DO NOT** top-off fuel. Wipe up any spilled fuel.
4. Pay attention to the fuel tank capacity when replenishing fuel. Refer to the fuel tank capacity listed in Table 2.

ENGINE OIL CHECK

1. Make sure the pump/engine is on level ground with the engine stopped.
2. Pull the engine oil dipstick from its holder and wipe it clean (Figure 8).

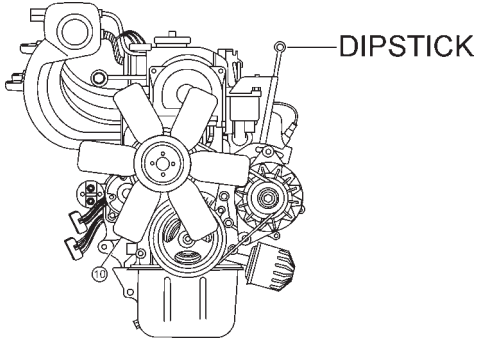


Figure 8. Engine Oil Dipstick Removal

3. Reinsert the dipstick.
4. Pull out the dipstick and check the oil level (Figure 9).

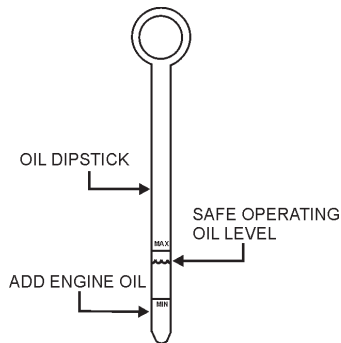


Figure 9. Engine Oil Dipstick Check

5. If the engine oil level is low, add oil through the engine oil filler hole (Figure 10) with the recommended oil type (Table 4). Maximum oil capacity is 3.49 quarts (3.3 liters).

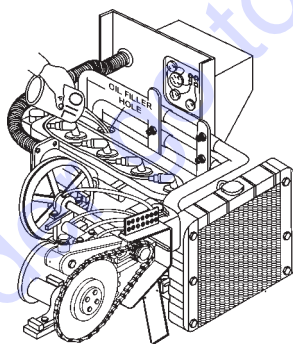


Figure 10. Engine Oil Filler Hole

Table 4. Oil Type		
Season	Temperature	Oil Type
Summer	25°C or Higher	SAE 10W-30
Spring/Fall	25°C~10°C	SAE 10W-30/20
Winter	0°C or Lower	SAE 10W-10

LUBRICATION BOX

The C30HDGA features a fully enclosed lubrication box, which utilizes the "SPLASH" method of lubrication.

Before using your new pump, 7 gallons of SAE 30 motor oil must be added directly into the lubrication box. Visually inspect the oil in the lubrication box by making sure the oil is at the correct operating level as indicated by the dipstick (Figure 11).

Also reference the oil level decal (Figure 12) adjacent to the lubrication box.

NOTICE

Make sure the pump is on a secure level surface when checking the oil level inside the lubrication box

NOTICE

The oil level must be checked daily to ensure adequate oil level and oil cleanliness.

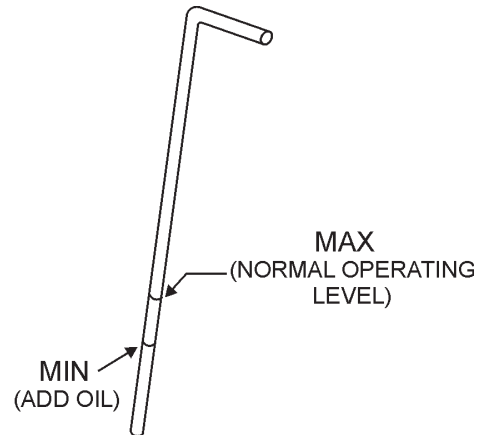


Figure 11. Lubrication Box Dipstick

CAUTION

NORMAL 
 LOW 
 A vertical double-headed arrow indicates a 1-inch difference between the two levels.

Before starting engine, check that the oil level inside the "LUBE BOX" is within the indicated operating range. Recommended oil type SAE 30.

DCL 152

Figure 12. Lubrication Box Oil Caution

CHECKING ENGINE COOLANT LEVEL

1. Remove the radiator cap, and check the cooling water level inside the radiator (Figure 13).
2. Maintain water/coolant level at top of radiator coils. Make sure radiator overflow bottle is filled to the proper level.

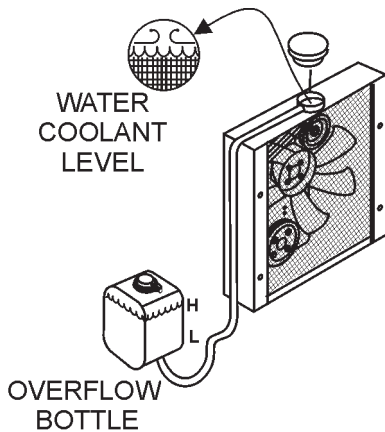



Figure 13. Radiator Coolant

WARNING



If adding coolant/antifreeze mix to the radiator, **DO NOT** remove the radiator cap until the unit has completely cooled. The possibility of hot coolant exists which can cause severe burns.

3. Check the radiator and hoses for any signs of leakage.
4. If cooling water is dirty, flush the cooling system.
5. When using antifreeze, mix the antifreeze coolant with water. Observe the instructions on the antifreeze container. Usually, a 50/50 mixture is a good choice.
6. When replacing the radiator cap, be sure to fit it securely back onto the radiator. If replaced loosely or incorrectly, the cooling water will quickly evaporate, causing the engine to overheat.

V-BELT

1. Inspect the V-belt (Figure 14) to determine if it is frayed, peeling, full of tiny cracks, has pieces of rubber missing, or is otherwise damaged.

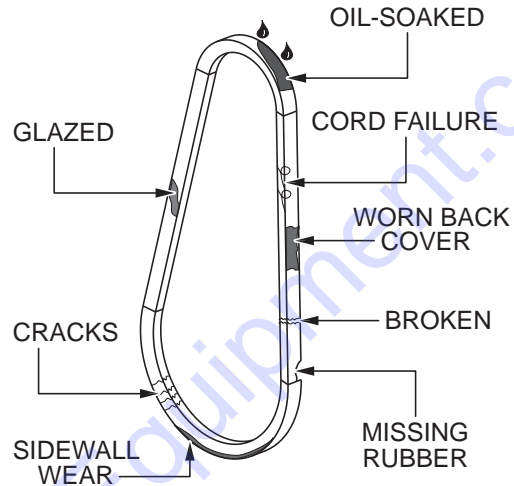


Figure 14. V-Belt Inspection

2. Inspect the V-belt to determine if it is oil-soaked or glazed (a hard, shiny appearance on the sides of the belt). Either of these conditions can cause overheating of the belt, which may weaken the belt and increase the danger of it breaking.
3. Replace the V-belt immediately if any of the aforementioned wear conditions are observed.
4. Check the V-belt tension (Figure 15) by pushing midway through the two pulleys. The V-belt deflection should be between .300 to .472 inches (8 to 121.3 mm).

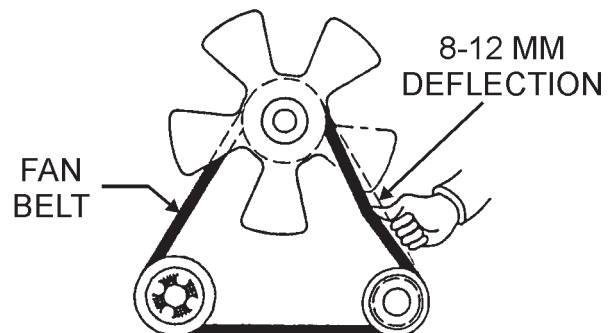


Figure 15. V-Belt Tension

STARTUP/SHUTDOWN

STARTING PROCEDURE

WARNING

DO NOT attempt to operate this concrete pump until the **Safety Information, General Information,** and **Inspection** sections have been read and understood.

1. Hold the throttle control switch fully to the RIGHT to set the engine speed to IDLE (Figure 16).

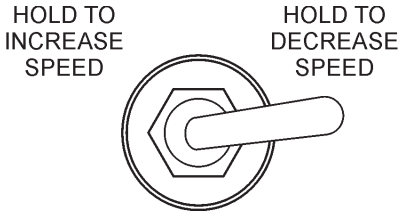


Figure 16. Throttle Control Switch

NOTICE

During pumping operations, the engine speed should not be reduced below 1300 RPMs to prevent the clutch from disengaging (slipping) during operation.

2. Place the pumping control switch (Figure 17) in the OFF position.

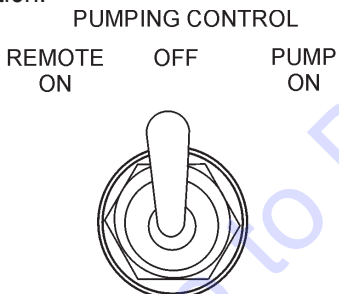


Figure 17. Pumping Control Switch (OFF)

3. Insert the ignition key into the ignition switch (Figure 18), turn the key to the ON position, then to the START position, release the key when the engine starts.

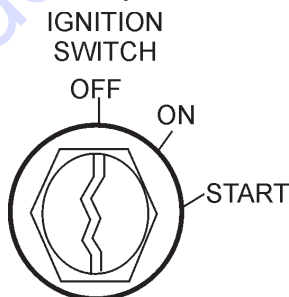


Figure 18. Ignition Switch

4. Let the engine run for 3-5 minutes before putting pump into operational use.
5. Listen for any abnormal sounds. If any mechanical or electrical problems exists, STOP the engine and correct the problem.
6. To begin pumping concrete. Place the pumping control switch (Figure 19) in the ON position.

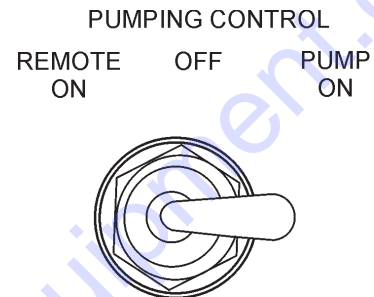


Figure 19. Pump Switch On

SHUTDOWN

1. Place the pumping control switch in the OFF position (Figure 17).
2. Let the engine run at idle speed for 3-5 minutes.
3. Turn the ignition key (Figure 18) to the OFF position.
4. Clean pump as referenced in the maintenance section of this manual.

OPERATING SUGGESTIONS

1. A well-planned location of the pump and routing of the hose before starting a pour may save subsequent moves throughout the job.
2. Before concrete is discharged into the hopper, it is suggested that 3 to 4 gallons of water be sprayed into the hopper, followed by approximately 5 gallons of a creamy cement and water slurry (1/2 bag of cement to 5 gallons of water). This procedure lubricates the hose and prevents separation and blockages in the hose.

NOTICE

Getting the concrete to flow through the hose at the start of the pumping cycle can be one of the most critical operations of the pour. Manually operate the throttle when starting, NOT remotely.

WARNING

If hoses or lines are blocked for any reason, or if the lines are kinked when starting up or during the pumping cycle, the pump pressure could straighten out the kink or force out the blockage. This rapid surge of material could cause the lines to whip or move in a manner that could cause injury to personnel.

Inspect the lines at all times to prevent the above conditions

3. It is important that once the slurry procedure is completed, and you have started concrete flowing through the hose, do not stop the pour until all the slurry is pumped out and the concrete has reached the end of the hose. The only time to stop the pump at the start is if a blockage occurs.
4. When the pump is stopped for any reason during a pour; e.g., moving hose, waiting for redi-mix truck, the following suggestions are offered:
 - a. Leave the hopper full of concrete at the time of shutdown. It is important not to let the redi-mix driver wash too much water into the hopper, as this could cause separation of the concrete in the hopper.
 - b. If the shutdown period exceeds 2 to 3 minutes, turn off the engine so the vibration does not separate the mix in the hopper which can cause a blockage in the manifold when the pump is started.

- c. It is necessary to wait 10 minutes or more for another load of concrete, it is wise to start the pump and pump 6 or 8 strokes every 5 minutes to prevent setting of the mix in the system. If waiting time is excessive, it would be wise to wash out the pump and hoses and start over when the new truck arrives.
- d. When pumping stiff mixes and there is waiting time between redi-mix trucks, it is advisable to add some water to the last hopper of material and "hand mix" to ensure an easier start with the following load.

When the pumping job requires a stiffer mix, the following method is suggested for starting: Take a water hose with a nozzle on it and apply water with a fine spray to the concrete as it comes down the redi-mix chute into the pump hopper after the slurry procedure is completed and you are ready to start pumping.

- e. Using this procedure will make it easier to pump through the clean hose. Note: Once the concrete has reached the end of the hose, do not apply any more water in this manner as this procedure is used on the start only.
 - f. Hose sizing is very important: We strongly recommend on harsh mixes, vertical pushes, stiff concrete, shotcrete, long pushes, that a 2 -1/2" line be used as far as possible. The advantages of using the 2 -1/2" line are improved pumpability, less pumping pressure and less wear on the pump.
5. Following the pump operation, proper wash out of all materials or "build-up" within the pump manifold and hoses will prevent problems when starting the next job.
 6. A thorough inspection of the drive components and greasing of all bearings after each job will ensure adequate lubrication and service to the pump which is normally operating in wet, gritty conditions.

NOTICE

Over-greasing any bearing on your Mayco pump will not damage the bearing.

WARNING

If you repeatedly increase speed and try to force your pump to push through blockages due to separation of material in the hose or manifold, you will soon have breakdowns and costly repairs which are not covered under warranty.

If a blockage occurs, find where it is and clear it before further pumping. DO NOT increase the engine speed to clear the blockage. Increasing the engine speed will only compound the problem.

WARNING

It will be necessary at times to move your pump from one job site location to another. Before moving the pump, make sure to pump the remaining concrete out of the hopper. Moving the pump with a full hopper of concrete can cause severe damage or bending of the axle and axle springs, excess strain and pressure on the hub and bearing assembly.

NEW PUMPS

All new pumps are “water pressure tested” at the factory before shipment. This procedure permits a thorough inspection of the entire drive system and valving under simulated full load conditions.

The pump owner can do the same by attaching an adaptor couple to the end of the discharge cone; e.g., the use of a standard 2 in. pipe cap with a 3/8 in. hole drilled in the center, screwed on to the end of the hinged cone or reducer at the pump.

Fill the hopper with water after making sure that all sand and rock have been removed from the manifold. Operate the pump at full throttle and the 3/8 in. diameter hole restriction will create sufficient back-pressure to make a thorough inspection of all moving parts.

PUMPING TIPS

1. The effects of heat and excessive time on concrete: Hot concrete, commonly referred to as a hot load, is concrete that has been in the redi-mix truck in excess of 2 to 3 hours. On a hot day, this amount of time is even less. A brief explanation of why heat and time affect concrete:

Concrete starts setting by drying up through a chemical reaction. The catalyst to this reaction is heat. When pumping a hot load, it is important to remember that when you have to stop pumping for any reason, add water to the concrete in the hopper and hand mix and move concrete in the hose every 5 minutes. If the shut down time becomes too long, wash out immediately.

2. ADMIXTURES

Remixtures that are designed into the concrete mix by the redi-mix company or an architectural engineering company. This section lists common admixtures and a brief explanation of their functions:

- a. **Pozzolith 300** – or the equivalent acts as a water retarder and a lubricant. On a lean mix, long pushes, stiff mixes, and vertical pushes, Pozzolith 300R helps pumpability.
- b. **MBVR** – air entraining, acts as a lubricant.
- c. **Calcium Chloride** – commonly referred to as C.C., is used as an accelerator. When pumping a load with calcium chloride, it is recommended that you wash out if the waiting time between delivery trucks becomes too long.
- d. **Super Plasticizers** – acts as an accelerator. The concrete will look very wet after the super plasticizer is added, but will begin to set up very fast. Wash out immediately if you do not have a truck waiting. Super plasticizers are used mainly on commercial jobs.
- e. **Red Label** – acts as a water retarder and an accelerator. Red label will be used mainly on commercial jobs.
- f. **Fly Ash** – is used to help increase the strength of the concrete and decrease the cement content per yard. This is one of the most common admixtures used.

NOTICE

All admixtures will be shown on the redi-mix concrete ticket. Before starting the pumping job, ask the driver of the redi-mix truck to see the concrete ticket and note the admixtures that exist and take the proper action.

3. When pumping long distance or pumping stiff mixes, you can expect a drop in volume compared to shorter lines and wetter mixes due to the change in valve efficiency or cavitation.
4. Leaking manifold seals or hose coupling gaskets which leak water can cause separation and subsequent jamming at that point.
5. Damaged hoses with internal restrictions can cause blockages.
6. If a blockage occurs in a hose, “walk the hose” until you find the point of trouble. The hose will be soft immediately past the blockage. If this happens at the start, disconnect the hose at the first coupling past the blockage.

Elevate the hose at that point with the blockage area hanging down.

Using a hammer, you can pound the down-stream edge of the packed area until it is free to flow. Shake all of the sand and gravel out to the end of the hose. Before reconnecting the hose, start the pump and run a small amount of concrete out to the end of the hose. This will assure that all of the separation is out of the hose.

CAUTION

When disconnecting hoses, use extreme CAUTION! The hose is under pressure.

7. Clearing a Plugged Manifold

The manifold is plugged if the volume at the discharge end of the hose stops, and the hose is soft. The drive belts will start to slip and the engine will lugdown.

Follow steps below to unplug a clogged manifold.

DANGER

Due to pressure build-up inside the manifold, great care must be taken when clearing a plugged manifold

- a. STOP the pump. Switch OFF the engine.
- b. DO NOT open any of the delivery system joint clamps.
- c. The senior operator must warn all others to stand

at least 20 feet away from the pump and turn their heads away from the manifold.

- d. The operator must position himself/herself away from the hinged side of the manifold.
- e. Wearing safety glasses, grasp the clamp arm weldment and carefully pull it open to the primary (safety) position. STOP count to 20. This will allow the pressure to release.
- f. After the pressure has been released, open the clamp arm weldment and swing the hinged discharge cone open.
- g. Remove blockage with a round 2-foot length of reinforcing steel rod. Flush the manifolds with water. Make sure the (3” x 2”) reducer is clear of any blockage before closing the discharge cone.
- h. After the blockage has been cleared and the pump manifold has been thoroughly flushed with water, close the hinged discharged cone and lock into place.
- i. Before reconnecting hose to the reducer, start the engine and pump two or three shovels of concrete through the reducer. This will insure that all the blockage has been cleared.
- j. Shake out around 2 feet of concrete before reconnecting hose to pump. After this is done, connect hose to pump and resume the pumping operation.

8. Avoiding Setting of the Mix in the System

To avoid setting of the concrete mix in the system when waiting more than 30 minutes between concrete loads, flush the system depending on job factors (such as presence of accelerators and job site temperature) and your particular mix design.

CLEARING A MIX FROM THE SYSTEM

If, for any reason, the mix should set up in the system, the following procedure is suggested:

CAUTION

When disconnecting hoses, use extreme CAUTION! The hose is under pressure.

1. Disconnect the hoses from the pump and wash the pump out immediately. For example: If you had 200 ft. of system out, you would disconnect each hose.
2. Reconnect the first hose and fill the hopper with water. DO NOT try to push all the concrete out of all of the hose lines at one time.
3. Clean it out by pushing water through the first hose off the pump, then continue progressing through all the hoses, until all the system is clean.
4. If waiting time is excessive, it would be wise to wash out the pump and hoses and start over when the new truck arrives. This can be avoided by being observant to the pump and system, also taking into consideration the above factors affecting the mix.

DOWNHILL PUMPING

Downhill pumping can be difficult on some jobs. It is suggested that a sponge 2"x 4"x 6" be placed in the hose before the start of pumping. Wet the sponge before placing it in the hose. Reference the Operating Suggestions at the start of this section for slurry procedures.

The reason for using the wet sponge is to keep the slurry from running too far ahead of the concrete and so reducing the possibility of separation. When the pump is stopped, the material can flow slowly down, due to gravity, and cause the hose to collapse.

When pumping is resumed, you can expect a blockage at the point of hose collapse. To prevent this from happening, the hose can be "kinked off" at the discharge end when the pump is stopped to prevent the gravity flow of the material in the hose.

The use of stiffer mixes when pumping down-hill will decrease gravity flow of the material in the hose and will assure a smoother operation between the cam roller bearing and cam plate. As with any job, make sure that the hose and the couplings are in good workable shape.

VERTICAL PUMPING

When pumping vertically up the side of a building, above 40 feet, we would recommend the installation of steel pipe securely fastened at intervals as necessary to support the pipe. Ninety degree, long radius pipe sweeps should be installed at the top and bottom of the steel line.

Use a 25 ft. hose, or short section, off the pump; and for the balance of the horizontal distance to the vertical line, use steel pipe. This type of installation has been satisfactory on many jobs being pumped in excess of 100 feet high. Line pressures are always less using steel pipe as compared to hose.

When pumping vertically using all hose, it is recommended not to go higher than 50 feet with hose. The hose should be tied off at intervals of 10 feet, if possible. Special attention should be given when tying the hose off at the top as the hose will have a tendency to stretch when filled with concrete. This will increase the possibility of a blockage at the point where the hose is tied off. To avoid this, a long radius of 90 degree elbow is recommended. The suggested place to tie off is on the hose, under the clamp.

NOTICE

It is strongly recommended that steel pipe be used on all vertical pumping for safety and convenience.

VALVE SEATS

If the volume at the end of hose starts to decrease gradually and eventually almost stops, it is quite likely that the valve seats have had excessive wear and need replacement. Once they have reached a certain wear point, they may "channel out" rapidly and material will reciprocate past the ball on each stroke.

The hollow steel ball should be replaced when it starts to show dents or appears to be badly worn. Sand and aggregate materials in some areas are extremely sharp and hard and therefore highly abrasive. Under these conditions when pumping stiff mixes, or to high elevations which cause line pressures, it will be noted that valve components may have short wear life.

If this condition exists, it is advisable to remove the manifold only, and inspect the lower seat at the end of each day. If it appears that the seat is beginning to "channel out", replace before starting the next day's pour.

The upper valve seat can be inspected after each washout by running your finger around lower edge of seat where the ball makes contact. You can reach this from the inside of the hopper. Be sure that the engine is turned off.

PULSATION

A slight pulsation of the hose will always be noticeable near the pump. Excessive pulsation of the hose near the pump is normally due to higher than average line pressures caused by stiff, harsh mixes, or extremely long pumping distances.

The use of 2 -1/2" I.D. hose in these extreme cases reduces line pressures or the addition of slight amounts of water to the mix, if permissible, will permit easier pumping. The use of certain pumping admixtures may help.

If excessive pulsation exists in the hose, it is advisable to use burlap or some means of wear protection under the hose at points where the hose may wear through the outer cover; e.g. over forms, steel or sharp curbs.

CAM ROLLER

If the cam roller does not ride on the cam profile smoothly, it may be caused by insufficient line back-pressure; e.g., a wet mix with only 50 feet of hose. Add more hose as necessary. It can also be caused by cavitation or the passing of oversized aggregates through the valving, causing it to skip.

SNAP-JOINT

When using Snap-Joint couplings with gaskets to join hose, see that they are washed clean after each job. Keeping the hose ends clean (heavy duty) is very important for the best job setup. A thin coat of grease on the rubber gasket or dipping both coupling and gasket in water before coupling the hose will make for easier installation.

REMOTE CONTROL

1. Connect the hand-held remote control cable (Figure 20) to the control box.

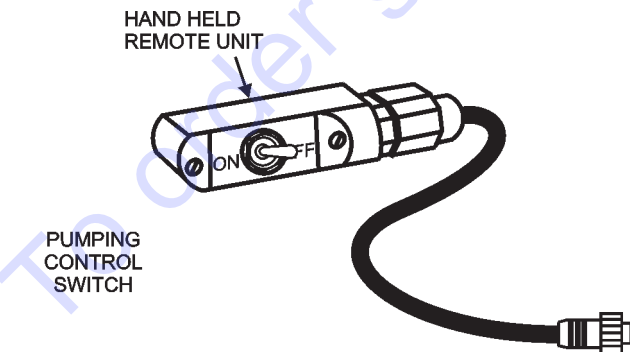


Figure 20. Handheld Remote Control Cable

2. On the control box, place the pumping control switch in the REMOTE ON position (Figure 21)

PUMPING CONTROL
 REMOTE ON OFF PUMP ON

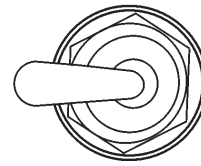


Figure 21. Pumping Control Switch (Remote)

RADIO REMOTE CONTROL OPERATION

The MAYCO C30HDGA Concrete Pump has a remote control feature (Figure 22) that allows the pump to be radio controlled via a receiver/transmitter technique.

Contact your MAYCO representative for further information regarding radio control pumping capability.

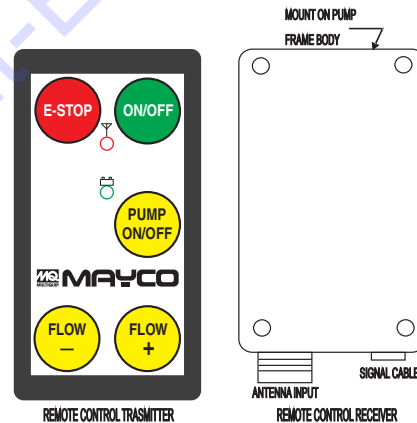


Figure 22. Handheld Radio Receiver/Transmitter

PREVENTIVE MAINTENANCE

It is extremely important to maintain this pump due to the highly abrasive nature of concrete material.

1. Inspect all drive components for loose or worn bolts.
2. Drive belt/chain should be checked to remove all slack. Refer to adjustment procedure.
3. ALWAYS carry extra "O" rings.
4. Keep entire pump clean of concrete to prevent build-up.
5. ALWAYS grease every fitting daily. Use only premium grade grease.

NOTICE

Over greasing will not damage pump.

GENERAL CLEAN-UP PROCEDURE

1. Ensure that there is no blockage in the hose and line or in the manifold. If a blockage exists, clear it to ensure proper operation the next time it is used. At the end of every pour, or during long delays during a pour, the pump and delivery system must be thoroughly cleaned by removing all concrete material.
2. Proper wash out of all materials or build up within the pump manifold and hoses following the pumping operation will prevent problems when starting the next job. After completion of the pour, pump the remaining concrete in the hopper through the discharge line.

NOTICE

To avoid the possibility of separation during clean-up, do not pump the concrete below the inlet ball in the hopper. It is best to leave approximately 3 to 4 inches of concrete above the inlet ball.

3. Turn the pump engine off before filling the hopper with water. Engine vibration at idle may "separate" material in the hopper, causing jamming in manifold when pumping is resumed.
4. Fill hopper with water and resume pumping. The water will push the concrete through the line. When the water runs clear at the end of the hose, disconnect lines and shake out all the sand and sediment so the lines will be clean for the next pour.

5. It is important that the hinged discharge cone on the pump manifold be opened and all remaining concrete (rock and sand) be thoroughly washed out. This must be done after each job to prevent concrete build up in the discharge manifolds and 3" discharge elbow.

SPONGE CLEAN-OUT PROCEDURE

This section will explain the recommended procedure for using a sponge to clean out the hose lines.

CAUTION

NEVER use muriatic acid to clear the pump. Acid will dissolve the chrome finish on the pumping cylinder.

NEVER use compressed air to clean out the lines.

When using a clean-out hook to clean out the rear of the redi-mix truck, use a safety chain to secure the clean-out hook to some solid part of the redi-mix truck to prevent the hook from jumping off the redi-mix truck's hopper. Run the pump at half throttle.

1. After completion of the pour, pump the remaining concrete in the hopper through the discharge line. Using a shovel, clean the sides of the hopper.

NOTICE

The pump engine should be turned OFF, as explained in General Clean Up Procedure.

After the sides of the hopper have been cleaned, add a small amount of water to the remaining concrete in the hopper and hand mix.

2. Start the pump engine and pump the hopper all the way down.
3. Disconnect the hose from the pump. Fill the hopper with water and pump the remaining concrete out of the pump.
4. Open the hinged discharge cone and thoroughly wash out all remaining concrete (sand-sediment) from the cone and pump manifolds. Close the discharge cone and lock in place.

5. Take a sponge (2"x 4"x 6") and soak it with water. Take the hose that is disconnected from the pump and shake out the concrete so that about 2 feet of it is clear. Insert the sponge into the hose.
6. Reconnect the hose to the pump. Fill the hopper with water and resume pumping. Run the pump approximately half throttle. The sponge will be discharged at the end of the line followed by clear water. At this point, the pump and lines will be completely clean and ready for the next job.
7. Repeat steps 1 through 6 a few times to ensure that the hose lines are thoroughly cleaned.

LUBRICATION BOX

The C30HDGA features a fully enclosed lubrication box, which utilizes the "SPLASH" method of lubrication.

Visually inspect the oil in the lubrication box (Figure 11) by making sure the oil is at the correct operating level as indicated by the dip stick. Also reference the oil level decal (Figure 12) adjacent to the lubrication box.

NOTICE

Make sure the pump is on a secure level surface when checking the oil level inside the lubrication box.

NOTICE

The oil level must be checked daily to ensure adequate oil level and oil cleanliness.

PISTON CUP WEAR

The rubber piston cups are a natural wear component and will require periodic replacement. The life of the rubber cups depends on many factors, proper oil level, oil cleanliness, abrasiveness of aggregate being pumped and material slump etc.

As the rubber piston cups wear, fine cement particles will accumulate in the bottom of the lubrication box. Once this cement paste reaches 1-inch in height, it is recommended that the lubrication box be drained (flushed) and cleaned and the oil replaced with new SAE 30 motor oil.

NOTICE

IMPORTANT! To ensure maximum cup life, the oil level in the lubrication box must be maintained at the proper level. In addition the lubrication box must be cleaned periodically.

NOTICE

There are two clean-out ports located at the bottom of the lubrication box.

CRANKSHAFT AND CAM ASSEMBLY PROCEDURE

1. Set bearing block (P/N EM14303) into hydraulic press. Place bearing cup into bearing block and press in evenly. Bearing cup should be aligned equally on both sides of bearing block.
2. Set crankshaft into hydraulic press with the long end towards the top. Install spacer (P/N EM14322), O-ring (P/N EM14326) and bearing cone (P/N EM14325) onto crankshaft. Place bearing block on crankshaft until the bearing cone is riding in the bearing cup.
3. Insert bearing cone spacer (P/N EM14323) onto crankshaft and inside bearing block. Install second bearing cone until it is seated inside bearing cup.
4. Place O-ring and spacer (P/N EM14302) on crankshaft. Set cam weldment on top of spacer. Install crankshaft key and cam key on cam bushing (P/N EM14301).
5. Slide cam bushing down crankshaft and align the bushing, cam and crankshaft. Install sleeve over crankshaft and align with hydraulic press. Install cam bushing bolts loosely. Press bushing down onto bearing assembly. Leaving pressure on the bushing, tighten cam bolts evenly to 40-50 foot pounds.
6. Release pressure on the bushing, reapply pressure to bushing and tighten bolts evenly to 40-50 foot pounds. Repeat procedure 3 to 4 times.
7. After bushing has been fitted tightly into cam, remove from hydraulic press. Remove one bolt at a time, using Loctite, install bolts and torque to 65-70 foot pounds. Counter sink set screw hole and install dog point set screw and second set screw both with LoctiteTM.
8. Place cam bearing onto crankshaft keeping bearing loose.

NOTICE

Make sure the eccentric lock is facing toward the outside of the pumping unit.

9. Set crankshaft assembly into the pump box and align both bearing assemblies with the pump box mountings.
10. After crankshaft assembly is securely fastened to the pump box, place sprocket (P/N EM14307) onto the cam side of the crankshaft assembly. Install bushing (P/N EM14309) into sprocket. Align sprocket with sprocket on countershafts and tighten bolts.
11. Install chain P/N EM14308. To adjust, loosen locknuts on pusher bolts and tighten chain to approximately 1/2 in. slack in the chain. Once chain is adjusted properly, tighten down locknuts.

BALL AND SEAT REPLACEMENT PROCEDURE

1. Remove 3"x 2" reducer and 3" elbow from the pump outlet. Remove exhaust gate and Y-manifold (secondary manifold). Check ball seat and ball stop pin for wear. If any wear is detected, the part should be replaced. Remove T-manifold (primary manifold). Check all parts for wear. Remove hopper and hopper seat and inspect.
2. Loosen the piston nuts and remove the piston cup assembly and cylinders. Inspect all parts for wear and replace parts with excessive wear. Check oiler pump for proper operation.
3. Clean all parts thoroughly, removing all foreign material and concrete slurry. Once parts are clean, install concrete cylinders. Place oiler plate O-ring in place and coat with oil. Install small O-ring on piston rod. Run oiler line through the cylinders and connect in the oiler fitting on the oiler plate.
4. Push oiler plate into cylinder. Install ring and felt holder, soak felt ring in oil, then install around felt holder in cylinder. Make sure the bronze ring is flat, then push it up flush with the ring and felt holder.
5. Coat piston cup with oil and push it into the cylinder. Install bushing into center of piston cup. Put small O-ring on rod, place face plate on rod and tighten down securely. Repeat these procedure on the opposite cylinder.
6. Thoroughly check T-manifold, ball stoppings and both steel balls for wear. Insert an O-ring in the top

flange and in the leading edge of the manifold. Put the manifold onto the primary side of the pump and install bolts leaving them loose.

7. Check Y-manifold for wear, install all O-rings, ball stop pin, ball and seat. Align and install Y-manifold to T-manifold and cylinder assembly. Tighten Y-manifold bolts first before tightening T-manifold bolts. After manifolds are tight, check O-rings for slippage.
8. Insert seat into frame hole directly above the T-manifold. The seat orifice should fit inside the frame itself, then the seat sits on top of the orifice. On the dura-seat, set the big end of the seat in the frame. The seat, or the small part of the dura-seat, fits into the bottom of the hopper.
9. After tightening the manifold bolts and inserting the seats in place, set the hopper over the seat and align the bolt holes. Tighten bolts, check O-ring and seat for alignment.
10. Check exhaust gate for wear, install and align gate onto Y-manifold. Insert O-ring into exhaust gate flange and close gate. Lock down lever and adjust clamp arm.
11. Install 3 in. elbow and 3x 2 in. reducer. Fill hopper half full and check for leaks.

BEARING INSTALLATION

1. Install the bearing components on the crankshaft making full contact with the back side of the crank disc as indicated the symbol #. See Figure 23 below.
2. Install the bushing in the cam weldment and slide it onto the crankshaft until contact is made with the bearing spacer.
3. Tighten the 3 allen head bolts "A" while exerting pressure on the bushing towards the bearing spacer.

NOTICE

It is important that the Bearing Assembly is installed properly.

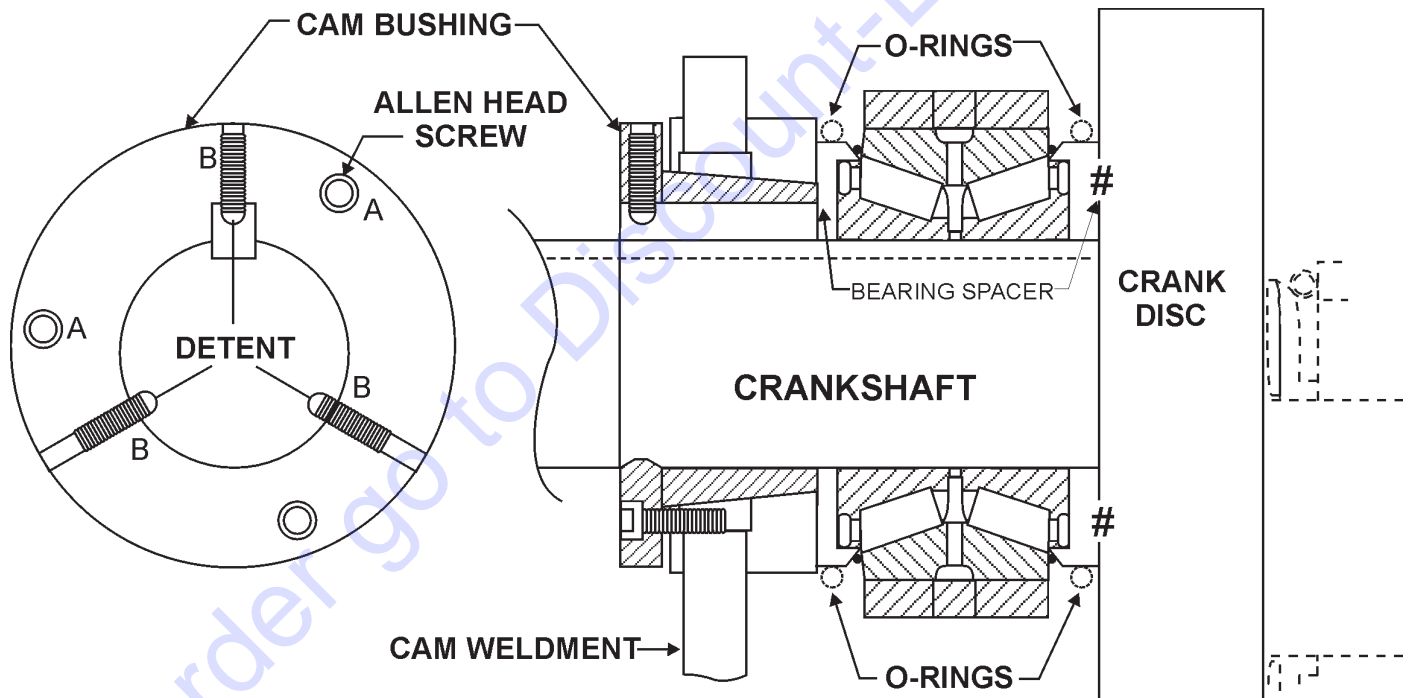


Figure 23. Bearing/Cam Bushing Installation

TO PURCHASE THIS PRODUCT PLEASE CONTACT US



**Equipment Financing and
Extended Warranties Available**



**Discount-Equipment.com is your online resource for
commercial and industrial quality parts and equipment sales.**

561-964-4949

visit us on line @ www.discount-equipment.com

Select an option below to find your Equipment

Search by Manufacturer

Search by Product Type

Request a Quote

We sell worldwide for the brands: Genie, Terex, JLG, MultiQuip, Mikasa, Essick, Whiteman, Mayco, Toro Stone, Diamond Products, Generac Magnum, Airman, Haulotte, Barreto, Power Blanket, Nifty Lift, Atlas Copco, Chicago Pneumatic, Allmand, Miller Curber, Skyjack, Lull, Skytrak, Tsurumi, Husquvarna Target, Stow, Wacker, Sakai, Mi-T-M, Sullair, Basic, Dynapac, MBW, Weber, Bartell, Bennar Newman, Haulotte, Ditch Runner, Menegotti, Morrison, Contec, Buddy, Crown, Edco, Wyco, Bomag, Laymor, EZ Trench, Bil-Jax, F.S. Curtis, Gehl Pavers, Heli, Honda, ICS/PowerGrit, IHI, Partner, Imer, Clipper, MMD, Koshin, Rice, CH&E, General Equipment, Amida, Coleman, NAC, Gradall, Square Shooter, Kent, Stanley, Tamco, Toku, Hatz, Kohler, Robin, Wisconsin, Northrock, Oztec, Toker TK, Rol-Air, APT, Wylie, Ingersoll Rand / Doosan, Innovatech, Con X, Ammann, Mecalac, Makinex, Smith Surface Prep, Small Line, Wanco, Yanmar

DETENT HOLE (3) INSTALLATION

1. After the bearing assembly has been installed, remove the three "dog type" allen head set screws (B) to allow detents to be drilled. See Figure 25 below

NOTICE

The detent holes will prevent the bushing from sliding away from the bearing spacer when the pump is under load.

2. Use a 9/32" drill to "detent" half (minimum 1/8" deep). Then "chase" the threads with a 3/8-16 bottom tap and blow out the chips after drilling, to be certain that the "dog type" allen set screws bottom in the detents to prevent the taper bushing from sliding laterally.

3. If this procedure is not followed closely the heavy loading of the bearing during pumping operation causes the Timken™ cone bearings to create lateral forces which will move the taper bushing and allow the Timken™ cone bearings to separate from the race and subsequently fail.

NOTICE

Position the 'O' ring on the O.D. of the bearing spacer during assembly to assure proper bearing adjustment.

4. Drill (detent) the shaft under the allen set screws "B" to prevent the bushing from the sliding away from the bearing spacer when the pump is under a load.

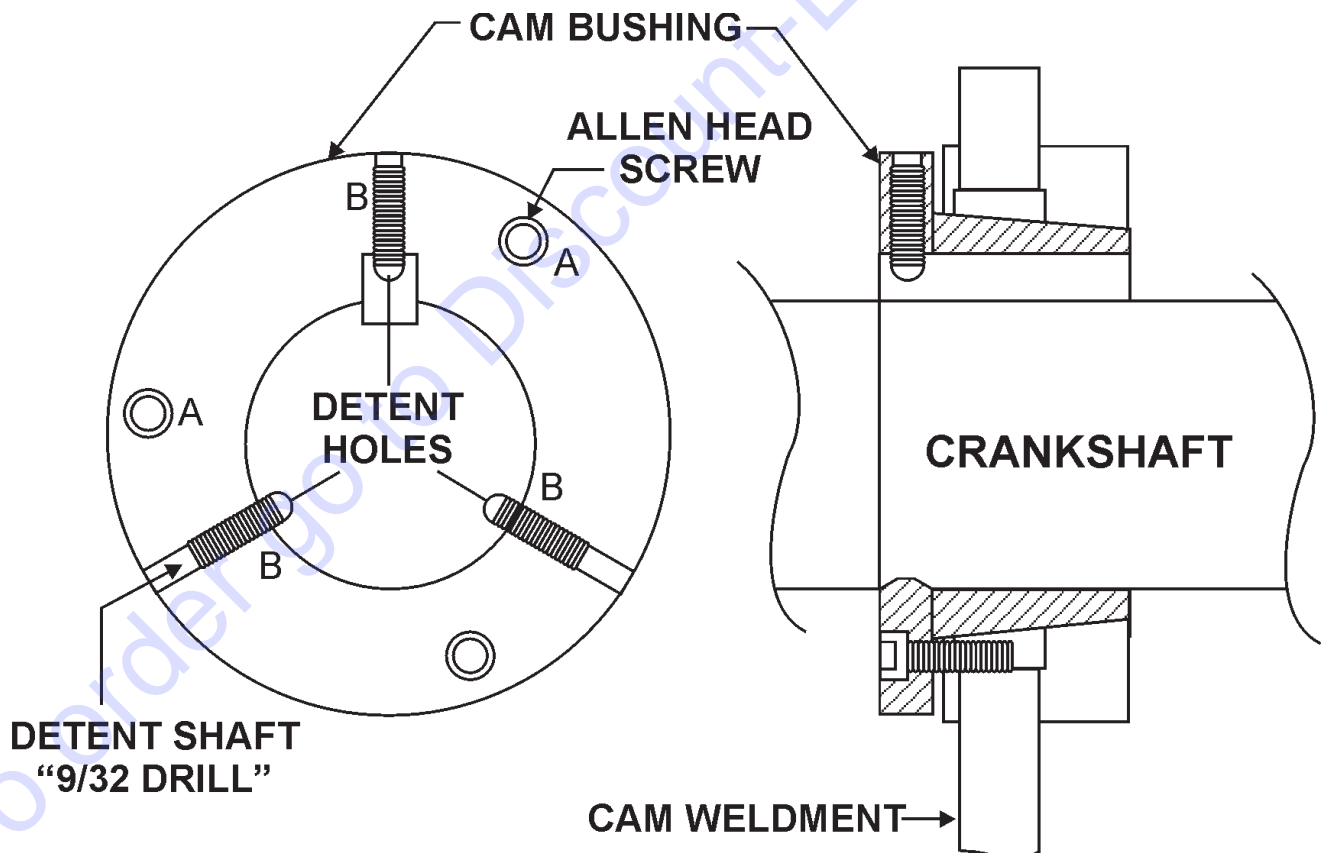


Figure 24. Detent Holes

V-BELT AND DRIVE CHAIN ADJUSTMENT

1. Loosen the pillow bearing bolts (Figure 25) only to the point where the bolts will remain snug.
2. Unlock the two pusher bolt lock nuts.
3. Turn each pusher bolt clockwise an equal amount until the chain is to proper adjustment of approximately 3/8 to 1/2 in. slack in the chain. It is very important that the pulley side and the chain side (pillow block bearings) are within 1/16" of an equal distance.
4. This distance can be checked by using a tape measure or a straight edge ruler, measuring from the inside of the pusher bolt bracket to the face of the pillow block bearing.
5. The drive chain should be adjusted regularly to remove all slack. Once all slack is removed, DO NOT over-adjust, as this will overload the shaft bearings. A slack chain on the crank drive creates backlash and shock loads on the shafts and bearings which results in shorter wear/life of the drive components.

6. Lubricate the chain regularly. It is advisable to carry a spare chain and master links for replacement in the field if necessary.
7. Drive belts should be regularly adjusted to prevent slippage. To adjust the belts, loosen the engine mounting bolts and move the engine until there is a maximum 3/4 in. deflection in the belts, retighten the engine mounting bolts.
8. Frequent inspections should be made on all drive components to make certain that all bolts and nuts remain tight.

NOTICE

Prior to adjusting the chain, place the lobe of the cam in the down position. The chain should have 83 rivets, including one each, half-link and full-link.

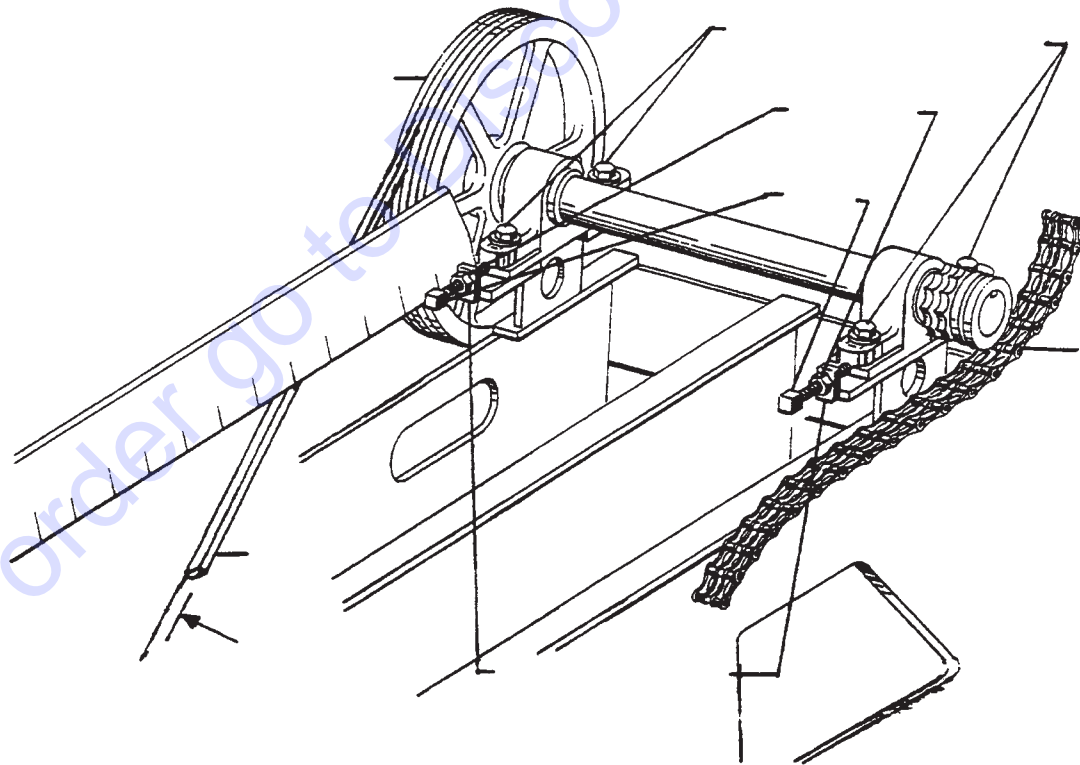


Figure 25. V-Belt and Drive Chain Adjustment

A properly selected, installed and maintained drive chain (Figure 26) is an extremely versatile means of power transmission. It is possible, however, to greatly reduce a chain's life and even induce failure if the chain is abused through improper installation, operating or maintenance procedures. In certain applications, failure can lead to personal injury or property damage.

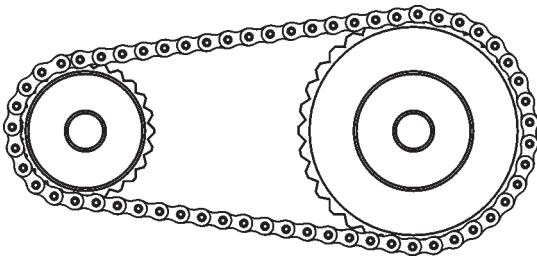


Figure 26. Drive Chain

Recommendations and comments on how to get the most from your roller chain drive are given in this section.

WORKING LOADS

UTS (Ultimate Tensile Strength) is the one-time pull required to break the chain. For single strand chain, the load (pull) applied to the chain in service should never exceed 1/6th of the UTS for the chain being used except as noted below.

It is possible to exceed the allowable working loads for a limited number of cycles, but you should contact Diamond Chain Company before this is considered. A roller chain should never be loaded above 50% of UTS for even one cycle. To do so will damage the chain structure and reduce its capacity.

The UTS or one time breaking load of multiple strand chain is the UTS of a single strand chain times the number of strands; i.e., two strand chain is twice as strong as single.

When allowable working loads are considered, however, the capacity of each strand in a multiple strand chain is only 65% of the single strand rating; thus, three-strand chain would rate not three times single but only 1.95 times. This is because the chain load cannot be exactly distributed across all three strands of the three-strand chain.

INSTALLATION AND DRIVE ALIGNMENT

Chain and sprockets (Figure 27) must be installed correctly. Sprockets must be properly aligned and sprocket shafts must be parallel so the drive will run in a plane perpendicular to them. Axial alignment should be checked with a straight edge which will extend across the finished sides of the sprockets. They should be true-running with minimum wobble and eccentricity. The higher the drive speed, the more important these details become.

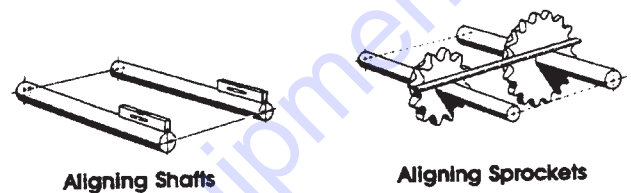


Figure 27. Shaft and Drive Sprocket Alignment

The chain should be installed so the slack span is properly tensioned. To check chain tension (Figure 28), turn one sprocket to tighten the upper span of the chain while holding the other sprocket fixed. The lack span should have 4-6% of span length in the mid-span movement for horizontal drives and 2-3% for vertical drives.

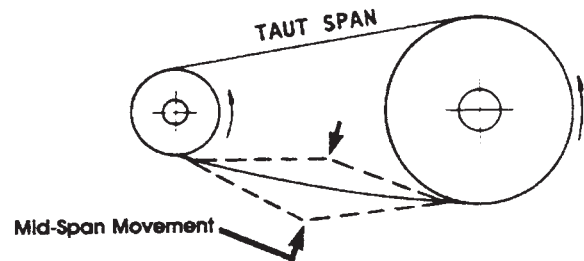


Figure 28. Drive Chain Tension

A roller chain's capacity can be significantly reduced if it is twisted or bent sideways in the direction of the pin axis. Exercise particular care in alignment of hoist or other applications where loads are suspended near personnel.

DRIVE CHAIN LUBRICATION

As a chain articulates in entering and leaving a sprocket, there is relative movement between pin and bushing surfaces. These surfaces wear causing chain elongation. If a lubricant film can be maintained between the pin and bushing, the wear rate is very slow and the chain wear life very long. Maintaining the oil film is relatively simple at low speeds but becomes increasingly difficult as the speed increases.

It is recognized that good lubrication is not possible in many applications, so shorter wear life must be accepted in these situations.

In general, chain wear leads to rough or unsatisfactory service prior to actual chain breakage. Good lubrication can help to prevent chain failure by providing protection against rust or corrosion. Rusting can allow pits to form in the surfaces of the chain parts causing stress concentration points. This can lead to chain failure at relatively low loads.

The clearance between pin and bushings is very small (Figure 29), on the order of .003 to .005 inches. A lubricant must be thin enough to flow into the chain. SAE 30 weight oil is about right for room temperature. Lighter oil should be used for lower ambients and heavier for higher operating temperatures. Grease should not be used as it cannot penetrate chain clearances

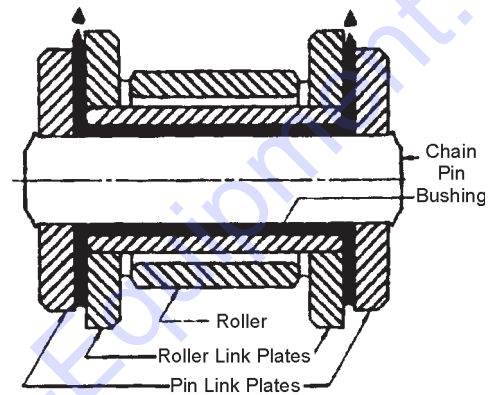


Figure 29. Chain-Link Cross Section

ASSEMBLING AND DISASSEMBLING DRIVE CHAIN

CAUTION

You may be seriously injured if you attempt to install the drive chain while the pump is running. Turn off the engine and lock out gears and sprockets before attempting installation.

Once installed, the drive chain must be guarded to prevent personal injury or property damage in the event the chain separates during operation. NEVER run pump with drive chain guard removed.

CAUTION

The components of the drive chain are hardened parts. Striking these parts may cause metal chips to break off from the chain or the tools used resulting in personal injury.

During all stages of chain disassembly and assembly, wear safety glasses to prevent metal parts or chips from entering your eyes and have personnel in the immediate area do likewise.

CHAIN-LINK PIN REMOVAL

1. If chain is of cotter pin- type construction, remove cotters.
2. If chain is riveted type construction, grind pin heads off so pin ends are flush with the linkplate.
3. Drive pins out of linkplate using a Diamond pin extractor Model P/N 113 or 135. Some multiple strand chains or large pitch models will require a hammer and punch or a press to remove the pins.

INSTALLATION OF COVERSIDES

Diamond Chain coversides are manufactured three different ways:

- Slip Fit
- Modified Press Fit
- Full Press Fit

NOTICE

Modified and Full Press Fits require some patience and tools to assemble and/or disassemble. Use vice grips, plumbers pliers or a small hammer to drive coversides onto pins

INSTALLATION OF SPRING LOCKS AND COTTER-PINS

After coversides have been installed, install spring locks or cotters (depending on chain design). Avoid using bent or worn cotters or spring locks. After spring locks (or cotters) are installed, lightly tap pin ends to position these parts snug against the coverside for additional support.

TIPS TO REMEMBER

- Chain will break if misused or abused
- Serious injury or property damage can result if chain is installed incorrectly.
- Select, install, guard and maintain chain in accordance with equipment manufacturer and "Diamond Chain Company's recommendations.
- Read chain assembly instructions before attempting to install chain on pump sprocket wheel.
- Knowing more about how the chain is constructed may help in assembly and disassembly. Further information may be obtained by calling or writing Diamond Chain Company™.

TRAILER MAINTENANCE

ADJUSTABLE CHANNEL

Your trailer may be equipped with an adjustable channel (Figure 30) that allows the coupler to be raised or lowered to a desired height. Periodically check the channel bolts for damage or loosening.

NOTICE

When replacing channel mounting hardware (nuts, bolts and washers), **NEVER** substitute substandard hardware. Pay close attention to **bolt length** and **grade**. **ALWAYS** use manufacturer's recommended parts when replacing channel mounting hardware.

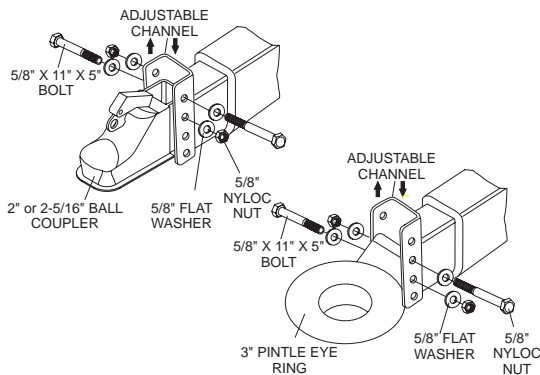


Figure 30. Adjustable Channel

Wheel Bearings

Wheel bearings (Figure 31) must be inspected and lubricated once a year or 12,000 miles to insure safe operation of your trailer.

If trailer wheel bearings are immersed in water, they must be replaced.

DANGER

If trailer wheels are under water for a long period of time, wheel bearings may fail. If this is the case, service wheel bearings immediately.

The possibility exists of the wheels falling off causing equipment damage and severe bodily harm even death!

If the trailer has not been used for an extended amount of time, have the bearings inspected and packed more frequently, at least every six months and prior to use.

Follow the steps below to disassemble the wheel hub and service the wheel bearings. See Figure 31.

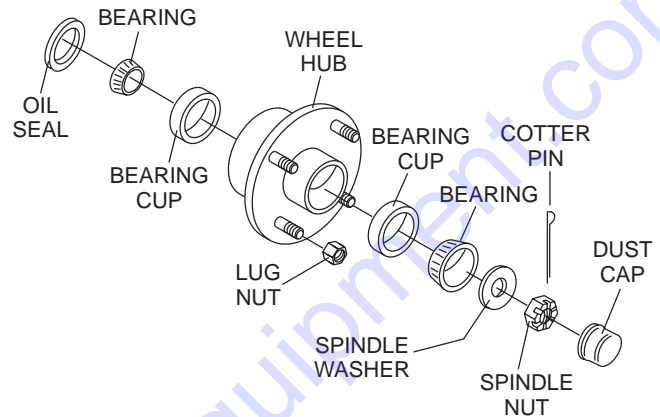


Figure 31. Wheel Hub Components

- After removing the dust cap, cotter pin, spindle nut and spindle washer, remove the hub to inspect the bearings for wear and damage.
- Replace bearings that have flat spots on rollers, broken roller cages, rust or pitting. Always replace bearings and cups in sets. The inner and outer bearings are to be replaced at the same time.
- Replace seals that have nicks, tears or wear.
- Lubricate the bearings with a high quality EP-2 automotive wheel bearing grease.

WHEEL HUB ADJUSTMENT

Every time the wheel hub is removed and the bearings are reassembled, follow the steps below to check the wheel bearings for free running and adjust.

- Turn the hub slowly, by hand, while tightening the spindle nut until you can no longer turn the hub by hand.
- Loosen the spindle nut just until you are able to turn it (the spindle nut) by hand. Do not turn the hub while the spindle nut is loose.
- Install a new cotter pin through the spindle nut and axle.
- Check the adjustments. Both the hub and the spindle nut should be able to move freely (the spindle nut motion will be limited by the cotter pin).

TRAILER MAINTENANCE

! DANGER

NEVER crawl under the trailer unless it is on firm and level ground and resting on properly placed and secured jackstands.

The possibility exists of the trailer falling thus causing equipment damage and severe bodily harm even death!

! DANGER

When performing trailer inspection and maintenance activities, you must jack up the trailer using jacks and jackstands.

When jacking and using jackstands, place them so as to clear wiring and suspension parts (i.e., springs, torsion bars). Place jacks and jackstands inside of the perimeter strip on the supporting structure to which the axles are attached.

! DANGER

Improper weld repair will lead to early failure of the trailer structure and can cause serious injury or death.

DO NOT repair cracked or broken welds unless you have a certified welder perform the repair. If not, have the welds repaired by your dealer.

! WARNING

If the trailer is involved in an accident, have it inspected immediately by qualified personnel. In addition, the trailer should be inspected annually for signs of wear or deformations.

TORSION SUSPENSION

The mounting bracket and associated components (Figure 32) should be visually inspected every 6,000 miles for signs of excessive wear, elongation of bolt holes, and loosening of fasteners. Replace all damaged parts immediately.

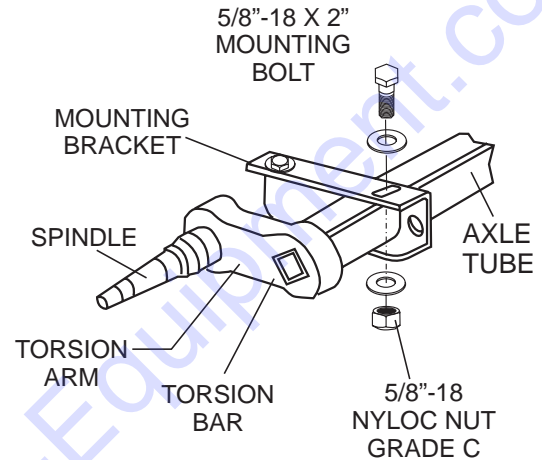


Figure 32. Torsion Suspension Components

! DANGER

Worn or broken suspension parts can cause loss of control, damage to equipment and severe bodily injury, even death!

Check suspension regularly.

TRAILER GUIDELINES

The following guidelines are intended to assist the operator in the operation and handling of a trailer.

Safety precautions should be followed at all times when operating a trailer. Failure to read, understand and follow the safety guidelines could result in injury to yourself and others. Loss of control of the trailer or tow vehicle can result in death or serious injury.

COMMON CAUSES FOR LOSS OF TRAILER

- Driving too fast for the conditions (maximum speed when towing a trailer is 55 mph).
- Trailer improperly coupled to the hitch.
- Not maintaining proper tire pressure.
- Not keeping lug nuts tight.
- Not properly maintaining the trailer structure.
- Ensure machine is towed level to tow vehicle.

TRAILER TOWING GUIDELINES

- Before towing, check coupling, safety chain, tires, wheels and lights.
- Check the lug nuts or bolts for tightness.
- Check coupler tightness after towing 50 miles.
- Use your mirrors to verify that you have room to change lanes or pull into traffic.
- Use your turn signals well in advance. Allow plenty of stopping space for your trailer and tow vehicle.
- Allow plenty of stopping space for your trailer and tow vehicle.
- **DO NOT** drive so fast that the trailer begins to sway due to speed.
- Allow plenty of room for passing. A rule of thumb is that the passing distance with a trailer is 4 times the passing distance without the trailer.
- Shift your automatic transmission into a lower gear for city driving.
- **ALWAYS** use lower gears for climbing and descending grades.

- **DO NOT** ride the brakes while descending grades, they may get so hot that they stop working. Then you will potentially have a runaway tow vehicle and trailer.
- To conserve fuel, don't use full throttle to climb a hill. Instead, build speed on the approach.
- Slow down for bumps in the road. Take your foot off the brake when crossing the bump.
- **DO NOT** brake while in a curve unless absolutely necessary. Instead, slow down before you enter the curve and power through the curve. This way, the towing vehicle remains in charge.
- **DO NOT** apply the brakes to correct extreme trailer swaying. Continued pulling of the trailer, and even slight acceleration, will provide a stabilizing force.
- Anticipate the trailer "swaying." Swaying is the trailer reaction to the air pressure wave caused by passing trucks and buses. Continued pulling of the trailer provides a stabilizing force to correct swaying. **DO NOT** apply the brakes to correct trailer swaying.
- Use lower gear when driving down steep or long grades. Use the engine and transmission as a brake. Do not ride the brakes, as they can overheat and become ineffective.
- Be aware of your trailer height, especially when approaching roofed areas and around trees.
- Make regular stops, about once each hour. Confirm that:
 - Coupler is secure to the hitch and is locked.
 - Electrical connectors are secure.
 - There is appropriate slack in the safety chains.
 - Tires are not visibly low on pressure.

TRAILER GUIDELINES

DRIVING CONDITIONS

When towing a trailer, you will have decreased acceleration, increased stopping distance, and increased turning radius (which means you must make wider turns to keep from hitting curbs, vehicles, and anything else that is on the inside corner). In addition, you will need a longer distance to pass, due to slower acceleration and increased length.

- Be alert for slippery conditions. You are more likely to be affected by slippery road surfaces when driving a tow vehicle with a trailer, than driving a tow vehicle without a trailer.
- Check rearview mirrors frequently to observe the trailer and traffic.
- **NEVER** drive faster than what is safe.

WARNING

Driving too fast for severe road conditions can result in loss of control and cause death or serious injury.

Decrease your speed as road, weather, and lighting conditions deteriorate.

Always check for local trailer tow speed limits in your area.

COUPLING TO THE TOW VEHICLE

Follow all of the safety precautions and instructions in this manual to ensure safety of persons, equipment, and satisfactory life of the trailer. Always use an adequate tow vehicle and hitch. If the vehicle or hitch is not properly selected and matched to the Gross Vehicle Weight Rating (GVWR) of your trailer, you can cause an accident that could lead to death or serious injury.

If you already have a tow vehicle, know your vehicle tow rating and make certain the trailer's rated capacity is less than or equal to the tow vehicle's rated towing capacity. If you already have (or plan to buy) a trailer, make certain that the tow rating of the tow vehicle is equal to or greater than that of the trailer.

The trailer VIN tag contains the critical safety information for the use of your trailer. Again, be sure your hitch and tow vehicle are rated for the Gross Vehicle Weight Rating of your trailer.

WARNING

Proper selection and condition of the coupler and hitch are essential to safely towing your trailer. A loss of coupling may result in death or serious injury.

- Be sure the hitch load rating is equal to or greater than the load rating of the coupler.
- Be sure the hitch size matches the coupler size.
- Observe the hitch for wear, corrosion and cracks before coupling. Replace worn, corroded or cracked hitch components before coupling the trailer to the tow vehicle.
- Be sure the hitch components are tight before coupling the trailer to the tow vehicle.

WARNING

An improperly coupled trailer can result in death or serious injury.

DO NOT move the trailer until:

- The coupler is secured and locked to hitch.
- The safety chains are secured to the tow vehicle.
- The trailer jack(s) are fully retracted.

DO NOT tow the trailer on the road until:

- Tires and wheels are checked.
- The trailer lights are connected and checked.

WARNING

Use of a hitch with a load rating less than the load rating of the trailer can result in loss of control and may lead to death or serious injury.

Use of a tow vehicle with a towing capacity less than the load rating of the trailer can result in loss of control, and may lead to death or serious injury.

Be sure your hitch and tow vehicle are rated for the Gross Vehicle Weight Rating of your trailer.

TRAILER GUIDELINES

INOPERABLE LIGHTS OR MIRRORS

Be sure that all of the lights on your trailer are functioning properly before towing your trailer. Check the trailer taillights by turning on your tow vehicle headlights. Check the turn signal lights. See Trailer Wiring Diagram section in this manual.

Standard mirrors usually do not provide adequate visibility for viewing traffic to the sides and rear of a towed trailer. You must provide mirrors that allow you to safely observe approaching traffic.

WARNING

Improper electrical connection between the tow vehicle and the trailer will result in inoperable lights and can lead to collision.

Before each tow, check that the tail lights and turn signals work.

TRAILER TOWING TIPS

Driving a vehicle with a trailer in tow is vastly different from driving the same vehicle without a trailer in tow. Acceleration, maneuverability and braking are all diminished with a trailer in tow.

It takes longer to get up to speed, you need more room to turn and pass, and more distance to stop when towing a trailer. You will need to spend time adjusting to the different feel and maneuverability of the tow vehicle with a loaded trailer.

Because of the significant differences in all aspects of maneuverability when towing a trailer, the hazards and risks of injury are also much greater than when driving without a trailer. You are responsible for keeping your vehicle and trailer in control, and for all the damage that is caused if you lose control of your vehicle and trailer.

As you did when learning to drive an automobile, find an open area with little or no traffic for your first practice trailering. Of course, before you start towing the trailer, you must follow all of the instructions for inspection, testing, loading and coupling. Also, before you start towing, adjust the mirrors so you can see the trailer as well as the area to the rear of it.

Drive slowly at first, 5 mph or so, and turn the wheel to get the feel of how the tow vehicle and trailer combination responds. Next, make some right and left hand turns. Watch in your side mirrors to see how the trailer follows the tow vehicle. Turning with a trailer attached requires more room.

It will take practice to learn how to back up a tow vehicle with a trailer attached. Take it slow. Before backing up, get out of the tow vehicle and look behind the trailer to make sure that there are no obstacles.

Some drivers place their hands at the bottom of the steering wheel, and while the tow vehicle is in reverse, “think” of the hands as being on the top of the wheel. When the hands move to the right (counterclockwise, as you would do to turn the tow vehicle to the left when moving forward), the rear of the trailer moves to the right. Conversely, rotating the steering wheel clockwise with your hands at the bottom of the wheel will move the rear of the trailer to the left while backing up.

If you are towing a bumper hitch rig, be careful not to allow the trailer to turn too much because it will hit the rear of the tow vehicle. To straighten the rig, either pull forward or turn the steering wheel in the opposite direction.

TRAILER VIN TAG

Figure A below is a sample of the Vehicle Identification Number (VIN) Tag which is typically located on the left front of the trailer.



U/FABRIQUÉ PAR / DATE

R / PNRV KG (LB)

R (EACH AXLE) / PNRB (CHAQUE ESSIEU) KG (LB) TIRAS / PNEU

/ JANTAS

/ INFL. PRESS. / PRESS. DE GONFL. A FROID KPA (PSI / LPO) SINGLE DUAL

(VEHICLE CONFORMS TO ALL APPLICABLE U.S. FEDERAL MOTOR VEHICLE SAFETY STANDARDS IN EFFECT ON THE DATE OF MANUFACTURE SHOWN ABOVE.)
(LE VEHICULE CONFORME A TOUTES LES NORMES OUI LI SONT APPLICABLES EN VERTU DU REGLEMENT SUR LA SECURITE DES VEHICULES AUTOMOBILES DU CANADA EN VALEUR A LA DATE DE SA FABRICATION.)

/ N.I.N.: TYPE / TYPE: TRAILER TRA / REM FD-306 REV A

Figure A. Vehicle VIN Tag

The trailer VIN Tag contains the following critical safety information for the use of your trailer.

GAWR: The maximum gross weight that an axle can support. It is the lowest of axle, wheel, or tire rating.

Usually, the tire or wheel rating is lower than the axle rating, and determines GAWR.

TRAILER GUIDELINES

GVWR: The maximum allowable gross weight of the trailer and its contents. The gross weight of the trailer includes the weight of the trailer and all of the items within it. GVWR is sometimes referred to as GTWR (Gross Trailer Weight Rating), or MGTW (Maximum Gross Trailer Weight). GVWR, GTWR and MGTW are all the same rating.

The sum total of the GAWR for all trailer axles may be less than the GVWR for the trailer, because some of the trailer load is to be carried by the tow vehicle, rather than by the trailer axle(s). The total weight of the cargo and trailer must not exceed the GVWR, and the load on an axle must not exceed its GAWR.

PSIC: The tire pressure (psi) measured when cold.

VIN: The Vehicle Identification Number.

TOW VEHICLE

The towing hitch attached to your tow vehicle must have a capacity equal to or greater than the load rating of the trailer you intend to tow. The hitch capacity must also be matched to the tow vehicle capacity. Your vehicle dealer can provide and install the proper hitch on your tow vehicle.

SUSPENSION SYSTEM

Sway bars, shock absorbers, heavy duty springs, heavy duty tires and other suspension components may be required to sufficiently tow the trailer and pump.

SIDE VIEW MIRRORS

The size of the trailer that is being towed and your state law regulations determine the size of the mirrors. However, some states prohibit extended mirrors on a tow vehicle, except while a trailer is actually being towed. In this situation, detachable extended mirrors are necessary. Check with your dealer or the appropriate state agency for mirror requirements.

HEAVY DUTY FLASHER

A Heavy Duty Flasher is an electrical component that may be required when your trailer turn signal lights are attached to the tow vehicle flasher circuit.

ELECTRICAL CONNECTOR

An Electrical Connector connects the lights on the trailer to the lights on the towing vehicle.

EMERGENCY FLARES AND TRIANGLE REFLECTORS

It is wise to carry these warning devices even if you are not towing a trailer. It is particularly important to have these when towing a trailer because the hazard flashers of your towing vehicle will not operate for as long a period of time when the battery is running both the trailer lights and tow vehicle lights.

SAFETY CHAINS

If the coupler connection comes loose, the safety chains can keep the trailer attached to the tow vehicle. With properly rigged safety chains, it is possible to keep the tongue of the trailer from digging into the road pavement, even if the coupler-to-hitch connection comes apart.

JACKSTAND

A device on the trailer that is used to raise and lower the coupler. The jack is sometimes called the "landing gear" or the "tongue jack".

COUPLER TYPES

Two types of coupler used with the trailer are discussed below.

- Ball Hitch Coupler
- Pintel Eye Coupler

BALL HITCH COUPLER

A ball hitch coupler (Figure B) connects to a ball that is located on or under the rear bumper of tow vehicle. This system of coupling a trailer to a tow vehicle is sometimes referred to as "bumper pull."

TRAILER GUIDELINES

A ball hitch trailer may be fitted with a tongue jack that can raise and lower the coupler. The tongue jack is mounted to the A-frame (front or tongue) part of the trailer. By rotating the jack handle clockwise, the jack will extend and raise the tongue of the trailer.

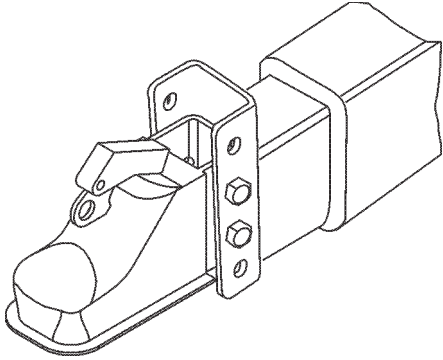


Figure B. Ball Hitch Coupler

Before each tow, coat the ball with a thin layer of automotive bearing grease to reduce wear and ensure proper operation. Check the locking device that secures the coupler to the ball for proper operation.

If you see or feel evidence of wear, such as flat spots, deformations, pitting or corrosion, on the ball or coupler, immediately have your dealer inspect them to determine the proper action to prevent possible failure of the ball and coupler system. All bent or broken coupler parts must be replaced before towing the trailer.

The coupler handle lever must be able to rotate freely and automatically snap into the latched position. Oil the pivot points, sliding surfaces, and spring ends with SAE 30W motor oil. Keep the ball socket and latch mechanism clean. Dirt or contamination can prevent proper operation of the latching mechanism.

The load rating of the coupler and the necessary ball size are listed on the trailer tongue. You must provide a hitch and ball for your tow vehicle where the load rating of the hitch and ball is equal to or greater than that of your trailer.

Also, the ball size must be the same as the coupler size. If the hitch ball is too small, too large, is underrated, is loose or is worn, the trailer can come loose from the tow vehicle and may cause death or serious injury.

THE TOW VEHICLE, HITCH AND BALL MUST HAVE A RATED TOWING CAPACITY EQUAL TO OR GREATER THAN THE TRAILER **Gross Vehicle Weight Rating (GVWR)**. IT IS ESSENTIAL THAT THE HITCH BALL BE OF THE SAME SIZE AS THE COUPLER.

The ball size and load rating (capacity) are marked on the ball. Hitch capacity is marked on the hitch.

⚠ WARNING

Coupler-to-hitch mismatch can result in uncoupling, leading to death or serious injury.

Be sure the **LOAD RATING** of the hitch ball is equal or greater than the load rating of the coupler.

Be sure the **SIZE** of the hitch ball matches the size of the ball coupler.

⚠ WARNING

A worn, cracked or corroded hitch ball can fail while towing and may result in death or serious injury.

Before coupling trailer, inspect the hitch ball for wear, corrosion and cracks.

Replace worn or damaged hitch ball.

⚠ WARNING

A loose hitchball nut can result in uncoupling, leading to death or serious injury.

Be sure the hitch ball is tight to the hitch before coupling the trailer.

- Rock the ball to make sure it is tightened to the hitch, and visually check that the hitch ball nut is solid against the lock washer and hitch frame.

- Wipe the inside and outside of the coupler. Clean and visually inspect it for cracks and deformations. Feel the inside of the coupler for worn spots and pits.

- Be sure the coupler is secured tightly to the tongue of the trailer. All coupler fasteners must be visibly solid against the trailer frame.

- The bottom surface of the coupler must be above the top of the hitch ball. Use the tongue jackstand to support the trailer tongue. Wood or concrete blocks may also be used.

TRAILER GUIDELINES

Coupling the Trailer to the Tow Vehicle (Ball Coupler)

- Lubricate the hitch ball and the inside of the coupler with a thin layer of automotive bearing grease.
- Slowly back up the tow vehicle so that the hitch ball is near or aligned under the coupler.
- Using the jackstand at the front of trailer (tongue), turn the jackstand crank handle to raise the trailer. If the ball coupler does not line up with the hitch ball, adjust the position of the tow vehicle.
- Open the coupler locking mechanism. Ball couplers have a locking mechanism with an internal moving piece and an outside handle. In the open position, the coupler is able to drop fully onto the hitch ball.
- Lower the trailer (Figure C) until the coupler fully engages the hitch ball.

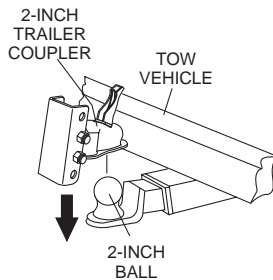


Figure C. Ball Hitch Coupling Mechanism

- Engage the coupler locking mechanism. In the engaged position, the locking mechanism securely holds the coupler to the hitch ball.
- Insert a pin or lock through the hole in the locking mechanism.
- Be sure the coupler is all the way on the hitch ball and the locking mechanism is engaged. A properly engaged locking mechanism will allow the coupler to raise the rear of the tow vehicle. Using the trailer jackstand, verify that you can raise the rear of the tow vehicle by 1 inch after the coupler is locked to the hitch.
- Lower the trailer so that its entire tongue weight is held by the hitch.
- Raise the jackstand to a height where it will not interfere with the road.

NOTICE

Overloading can damage the tongue jack. **DO NOT** use the tongue jack to raise the tow vehicle more than one inch.

If the coupler cannot be secured to the hitch ball, do not tow the trailer. Call your dealer for assistance. Lower the trailer so that its entire tongue weight is held by the hitch and continue retracting the jack to its fully retracted position.

Attaching Safety Chain

Visually inspect the safety chains and hooks for wear or damage. Replace worn or damaged safety chains and hooks before towing.

Attach the safety chains so that they:

- Cross underneath the coupler. See Figure D.

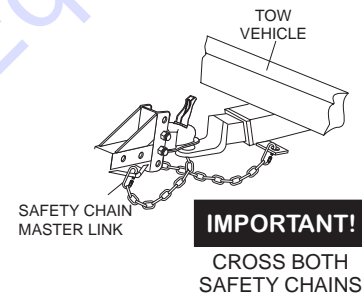


Figure D. Attaching Safety Chain (Ball Hitch)

- Loop around a frame member of the tow vehicle or holes provided in the hitch system (DO NOT attach them to an interchangeable part of the hitch assembly).
- Have enough slack to permit tight turns, but not be close to the road surface, so if the trailer uncouples, the safety chains can hold the tongue up above the road.

WARNING

Improper rigging of the safety chains can result in loss of control of the trailer and tow vehicle, leading to death or serious injury, if the trailer uncouples from the tow vehicle.

- Fasten chains to frame of tow vehicle. DO NOT fasten chains to any part of the hitch unless the hitch has holes or loops specifically for that purpose.
- Cross chains underneath hitch and coupler with enough slack to permit turning and to hold tongue up, if the trailer comes loose.

Connecting Trailer Lights

Connect the trailer lights to the tow vehicle's electrical system using the electric connectors at the front of the trailer (tongue). Refer to the wiring diagram shown in the trailer wiring diagram section of this manual. Before towing the trailer check for the following:

- Running lights (turn on tow vehicle headlights).
- Backup Lights (place tow vehicle gear shift in reverse).
- Turn Signals (activate tow vehicle directional signal lever).

WARNING

Improper electrical connection between the tow vehicle and the trailer will result in inoperable lights and electric brakes, and can lead to collision.

Before each tow:

- Check that the taillights, brake lights and turn signals work.

Uncoupling the Ball Hitch

Follow these steps to uncouple ball hitch from tow vehicle:

- Block trailer tires to prevent the trailer from rolling, before jacking the trailer up.
- Disconnect the electrical connector.
- Disconnect the breakaway brake switch cable. Promptly replace the pullpin in the switchbox.
- Before extending jackstand, make certain the ground surface below the jackstand foot will support the tongue load.
- Rotate the jackstand handle (or crank) clockwise. This will slowly extend the jack and transfer the weight of the trailer tongue to the jack.

PINTLE HITCH COUPLER

A pintle eye coupler (Figure E) connects to a pintle-hook hitch that is located on or under the rear bumper of the tow vehicle. This system of coupling a trailer to a tow vehicle is sometimes referred to as a "lunette eye, tow ring or G.I. hitch."

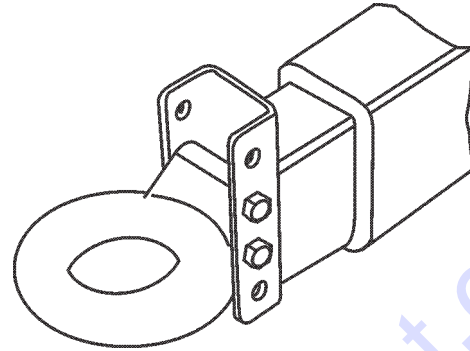


Figure E. Pintle Hitch Coupler

A pintle hitch trailer may be fitted with a tongue jackstand that can raise and lower the coupler. The tongue jack is mounted to the A-frame (front or tongue) part of the trailer. By rotating the jack handle clockwise, the jack will extend and raise the tongue of the trailer.

The load rating of the coupler and the necessary pintle hitch size are listed on the trailer tongue. You must provide a pintle hitch and pintle coupler for your tow vehicle, where the load rating of the pintle hitch and pintle coupler is equal to or greater than that of your trailer.

Also, the pintle hitch size must be the same as the pintle coupler size. If the hitch is too small, too large, underrated, loose or worn, the trailer can come loose from the tow vehicle, and may cause death or serious injury.

Pintle Coupler and Pintle Hook

Before each tow, check the locking device that secures the coupler to the pintle hook assembly.

The pintle hook lever must be able to operate freely and automatically snap into place into the latched position. Lightly oil the pivot points and sliding surfaces with SAE30W motor oil to prevent rust and help ensure proper operation of the latching mechanism.

If you see or feel evidence of wear, such as flat spots, deformations, pitting or corrosion, on the pintle hook or coupler, immediately have your dealer inspect them to determine the proper action to prevent possible failure of the ball and coupler system. All bent or broken coupler parts must be replaced before towing the trailer.

TRAILER GUIDELINES

THE TOW VEHICLE, PINTLE HITCH AND PINTLE COUPLER MUST HAVE A RATED TOWING CAPACITY EQUAL TO OR GREATER THAN THE TRAILER **Gross Vehicle Weight Rating (GVWR)**.

IT IS ESSENTIAL THAT THE PINTLE HITCH BE OF THE SAME SIZE AS THE PINTLE COUPLER.

The coupler size and load rating (capacity) are marked on the coupler. Hitch capacity is marked on the hitch.

WARNING

Coupler-to-hitch mismatch can result in uncoupling, leading to death or serious injury.

Be sure the **LOAD RATING** of the pintle hitch hook is equal or greater than the load rating of the pintle eye coupler.

Be sure the **SIZE** of the pintle hitch hook matches the size of the pintle eye coupler.

WARNING

A worn, cracked or corroded pintle hitch hook can fail while towing, and may result in death or serious injury.

Before coupling trailer, inspect the pintle hitch hook for wear, corrosion and cracks.

Replace worn or damaged pintle hitch hook.

- Rock the pintle eye coupler to make sure it is secured tightly to the hitch.
- Wipe the inside and outside of the pintle coupler. Clean and inspect it visually for cracks and deformations. Feel the inside of the coupler for worn spots and pits.
- Be sure the coupler is secured tightly to the tongue of the trailer. All coupler fasteners must be visibly solid against the trailer frame.
- Raise the bottom surface of the coupler to be above the top of the pintle hitch hook. Use the tongue jackstand to support the trailer tongue. Wood or concrete blocks may also be used.

WARNING

A defective pintle hitch not properly fastened can result in uncoupling, leading to death or serious injury.

Be sure the pintle hook is securely tightened to the tow vehicle before coupling the trailer.

Coupling Trailer to Tow Vehicle (Pintle Coupler)

- Slowly back up the tow vehicle so that the pintle hitch hook is near or aligned under the pintle eye ring coupler.
- Using the jackstand at the front of trailer (tongue), turn the jackstand crank handle to raise the trailer. If the pintle eye coupler does not line up with the pintle hitch hook, adjust the position of the tow vehicle.
- **OPEN** the pintle hook locking mechanism (Figure F). Place the hook inside the eye coupler. **CLOSE** the pintle hook mechanism.

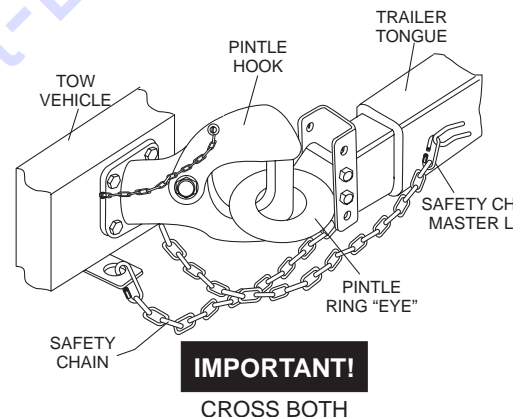


Figure F. Attaching Safety Chain (Pintle Hitch)

- Insert a pin or lock through the hole in the locking mechanism.
- Be sure the pintle hook is inserted completely through the eye ring and the locking mechanism is engaged. A properly engaged locking mechanism will allow the coupler to raise the rear of the tow vehicle. Using the trailer jack, test to see that you can raise the rear of the tow vehicle by 1-inch after the coupler is locked to the hitch.
- Lower the trailer so that its entire tongue weight is held by the hitch.
- Raise the jackstand to a height where it will not interfere with the road.

TRAILER GUIDELINES

TIRE SAFETY

Unsafe Tires, Lug Nuts or Wheels

Trailer tires and wheels are more likely to fail than car tires and wheels because they carry a heavier load. Therefore, it is essential to inspect the trailer tires before each tow.

If a tire has a bald spot, bulge, cuts, is showing any cords, or is cracked, replace the tire before towing. If a tire has uneven tread wear, take the trailer to a dealer service center for diagnosis.

Uneven tread wear can be caused by tire imbalance, axle misalignment or incorrect inflation.

Tires with too little tread will not provide adequate tracking on wet roadways and can result in loss of control, leading to death or serious injury.

Improper tire pressure causes an unstable trailer and can result in a tire blowout and loss of control. Therefore, before each tow you must also check the tire pressure. Tire pressure must be checked when tires are cold.

Allow 3 hours cool-down after driving as much as 1 mile at 40 mph before checking tire pressure. Trailer tires will be inflated to higher pressures than passenger vehicle tires.

Since trailer wheels and lug nuts (or bolts) are subjected to greater side loads than automobile wheels, they are more prone to loosen. Before each tow, check to make sure they are tight.

The proper tightness (torque) for lug nuts is listed in the lug nut tightening section of this manual. Use a torque wrench to tighten the lug nuts. If you do not have a torque wrench, use a lug wrench (from your tow vehicle) and tighten the nuts as much as you can. Then have a service garage or trailer dealer tighten the lug nuts to the proper torque.

WARNING

Metal creep between the wheel rim and lug nuts will cause rim to loosen and could result in a wheel coming off, leading to death or serious injury.

Tighten lug nuts before each tow.

Lug nuts are also prone to loosen after first being assembled. When driving a new trailer (or after wheels have been remounted), check to make sure they are tight after the first 10, 25 and 50 miles of driving and before each tow thereafter.

Failure to perform this check can result in a wheel parting from the trailer and a crash, leading to death or serious injury.

WARNING

Lug nuts are prone to loosen after initial installation, which can lead to death or serious injury.

Check lug nuts for tightness on a new trailer or when wheel(s) have been remounted after the first 10, 25 and 50 miles of driving.

WARNING

Improper lug nut torque can cause a wheel parting from the trailer, leading to death or serious injury.

Be sure lug nuts are tight before each tow.

WARNING

Improper tire pressure can result in a blowout and loss of control, which can lead to death or serious injury.

Be sure tires are inflated to pressure indicated on side wall before towing trailer.

Use the information contained in this section to make tire safety a regular part of your vehicle maintenance routine. Recognize that the time you spend is minimal compared with the inconvenience and safety consequences of a flat tire or other tire failure.

TIRE FUNDAMENTALS

Federal law requires tire manufacturers to place standardized information on the sidewall of all tires (Figure G). This information identifies and describes the fundamental characteristics of the tire and also provides a tire identification number for safety standard certification and in case of a recall.

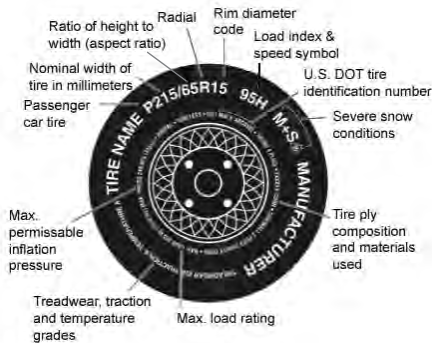


Figure G. Standard Tire Sidewall Information

P: The “P” indicates the tire is for passenger vehicles.

Next number: This three-digit number gives the width in millimeters of the tire from sidewall edge to sidewall edge. In general, the larger the number, the wider the tire.

Next number: This two-digit number, known as the aspect ratio, gives the tire’s ratio of height to width. Numbers of 70 or lower indicate a short sidewall for improved steering response and better overall handling on dry pavement.

P: The “R” stands for radial. Radial ply construction of tires has been the industry standard for the past 20 years.

Next number: This two-digit number is the wheel or rim diameter in inches. If you change your wheel size, you will have to purchase new tires to match the new wheel diameter.

Next number: This two- or three-digit number is the tire’s load index. It is a measurement of how much weight each tire can support. You may find this information in your owner’s manual. If not, contact a local tire dealer. *Note:* You may not find this information on all tires because it is not required by law.

M+S: The “M+S” or “M/S” indicates that the tire has some mud and snow capability. Most radial tires have these markings; hence, they have some mud and snow capability.

Speed Rating: The speed rating denotes the speed at which a tire is designed to be driven for extended periods of time. The ratings range from 99 miles per hour (mph) to 186 mph. These ratings are listed in Table A. *Note:* You may not find this information on all tires because it is not required by law.

Letter Rating	Speed Rating
Q	99 mph
R	106 mph
S	112 mph
T	118 mph
U	124 mph
H	130 mph
V	149 mph
W	168* mph
Y	186* mph

U.S. DOT Tire Identification Number: This begins with the letters “DOT” and indicates that the tire meets all federal standards. The next two numbers or letters are the plant code where it was manufactured, and the last four numbers represent the week and year the tire was built. For example, the numbers 3197 means the 31st week of 1997. The other numbers are marketing codes used at the manufacturer’s discretion. This information is used to contact consumers if a tire defect requires a recall.

Tire Ply Composition and Materials Used: The number of plies indicates the number of layers of rubber-coated fabric in the tire. In general, the greater the number of plies, the more weight a tire can support. Tire manufacturers also must indicate the materials in the tire, which include steel, nylon, polyester, and others.

Maximum Load Rating: This number indicates the maximum load in kilograms and pounds that can be carried by the tire.

Maximum Permissible Inflation Pressure: This number is the greatest amount of air pressure that should ever be put in the tire under normal driving conditions.

TRAILER GUIDELINES

Uniform Tire Quality Grading Standards (UTQGS)

Treadwear Number: This number indicates the tire's wear rate. The higher the treadwear number is, the longer it should take for the tread to wear down. For example, a tire graded 400 should last twice as long as a tire graded 200.

Traction Letter: This letter indicates a tire's ability to stop on wet pavement. A higher graded tire should allow you to stop your car on wet roads in a shorter distance than a tire with a lower grade. Traction is graded from highest to lowest as "AA," "A," "B," and "C".

Temperature Letter: This letter indicates a tire's resistance to heat. The temperature grade is for a tire that is inflated properly and not overloaded. Excessive speed, underinflation or excessive loading, either separately or in combination, can cause heat build-up and possible tire failure. From highest to lowest, a tire's resistance to heat is graded as "A," "B," or "C".

Refer to Figure H for additional tire information for light trucks.

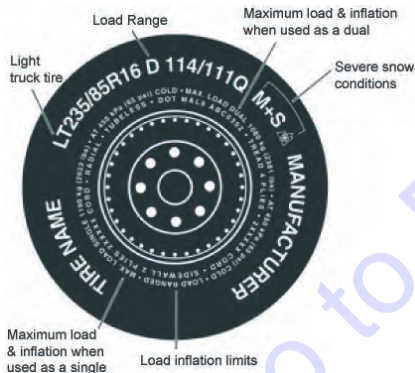


Figure H. UTQGS Tire Information

Tires for light trucks have other markings besides those found on the sidewalls of passenger tires.

LT: The "LT" indicates the tire is for light trucks or trailers.

ST: An "ST" is an indication the tire is for trailer use only.

Max. Load Dual kg (lbs) at kPa (psi) Cold: This information indicates the maximum load and tire pressure when the tire is used as a dual, that is, when four tires are put on each rear axle (a total of six or more tires on the vehicle).

Max. Load Single kg (lbs) at kPa (psi) Cold: This information indicates the maximum load and tire pressure when the tire is used as a single.

Load Range: This information identifies the tire's load-carrying capabilities and its inflation limits.

Tire Safety Tips

- Slow down if you have to go over a pothole or other object in the road.
- DO NOT run over curbs or other foreign objects in the roadway, and try not to strike the curb when parking.
- Check tire inflation pressure weekly during use to insure the maximum tire life and tread wear.
- DO NOT bleed air from tires when they are hot.
- Inspect tires for uneven wear patterns on the tread, cracks, foreign objects, or other signs of wear or trauma.
- Remove bits of glass and foreign objects wedged in the tread.
- Make sure your tire valves have valve caps.
- **ALWAYS** check tire pressure on tow vehicle and trailer before towing. Check tire pressure at least once a month.
- **DO NOT** overload tow vehicle. Check the tire information and loading placard for safe allowable tire loading conditions.

Tire Repair







The proper repair of a punctured tire requires a plug for the hole and a patch for the area inside the tire that surrounds the puncture hole. Punctures through the tread can be repaired if they are not too large, but punctures to the sidewall should not be repaired. Tires must be removed from the rim to be properly inspected before being plugged and patched.

Replacing Worn or Damaged Tires


Replace the tire before towing the trailer if the tire treads have less than 1/16 inch depth or the telltale bands are visible. Check inflation pressure weekly during use to insure the maximum tire life and tread wear. A bubble, cut or bulge in a side wall can result in a tire blowout. Inspect both side walls of each tire for any bubble, cut or bulge; and replace a damaged tire before towing the trailer.

TRAILER GUIDELINES

Table B below will help pinpoint the causes and solutions of tire wear problems.

Table B. Tire Wear Troubleshooting			
Wear Pattern	Cause	Solution	
	Center Wear	Over inflation.	Adjust pressure to particular load per tire manufacturer.
	Edge Wear	Under inflation.	Adjust pressure to particular load per tire manufacturer.
	Side Wear	Loss of camber or overloading.	Make sure load does not exceed axle rating. Align wheels.
	Toe Wear	Incorrect toe-in.	Align wheels.
	Cupping	Out-of-balance.	Check bearing adjustment and balance tires.
	Flat Spots	Wheel lockup and tire skidding.	Avoid sudden stops when possible and adjust brakes.

WARNING



ALWAYS wear safety glasses when removing or installing force fitted parts. **DO NOT** attempt to repair or modify a wheel. **DO NOT** install an inner-tube to correct a leak through through the rim. If the rim is cracked, the air pressure in the inner tube may cause pieces of the rim to explode (break off) with great force and cause serious eye or bodily injury.

Wheel Rims

If the trailer has been struck, or impacted, on or near the wheels, or if the trailer has struck a curb, inspect the rims for damage (i.e. being out of round); and replace any damaged wheel. Inspect the wheels for damage every year, even if no obvious impact has occurred.

Wheels, Bearings and Lug Nuts

Check wheel bearings, jack trailer and check wheels for side-to-side looseness. If the wheels are loose, or spin with a wobble, the bearings must be serviced or replaced. Check inflation pressure weekly during use to insure the maximum tire life and tread wear. Most trailer axles are built with sealed bearings that are not serviceable. Sealed bearings must be replaced as complete units.

NOTICE

NEVER use an pneumatic air gun to tighten wheel lug nuts.

Over-tightening lug nuts will result in breaking the studs or permanently deforming the mounting stud holes in the wheels.

WARNING

Lug nuts are prone to loosen after initial installation, which can lead to death or serious injury. Check all wheel lug nuts periodically.

Lug Nut Torque Requirements

It is extremely important to apply and maintain proper wheel mounting torque on the trailer. Be sure to use only the fasteners matched to the cone angle of the wheel. Proper procedure for attachment of the wheels is as follows:

1. Start all wheel lug nuts by hand.
2. Torque all lug nuts in sequence. See Figure I. **DO NOT** torque the wheel lug nuts all the way down. Tighten each lug nut in 3 separate passes as defined by Table C.
3. Check to see if the lug nuts are tight after the first 10, 25 and 50 miles of driving and before each tow thereafter.

TRAILER GUIDELINES

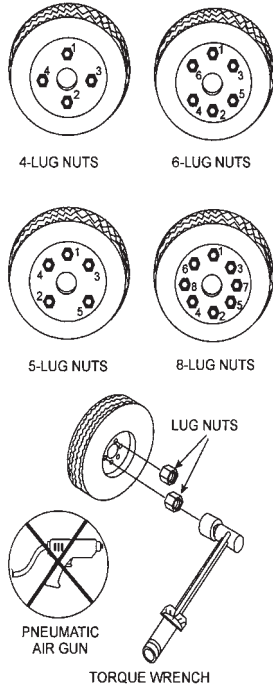


Figure I. Wheel Lug Nuts Tightening Sequence

Lights and Signals

Before each tow, check the trailer taillights, stoplights, turn signals and any clearance lights for proper operation.

Replace any broken or burned-out lamps as necessary. Check the wire harness for cuts, fraying or other damage. If it needs replacing, contact your dealer.

⚠ WARNING

Improper operating taillights, stoplights and turn signals can cause collisions.

Check all lights before each tow.

Table C. Tire Torque Requirements

Wheel Size	First Pass FT-LBS	Second Pass FT-LBS	Third Pass FT-LBS
12"	20-25	35-40	50-65
13"	20-25	35-40	50-65
14"	20-25	50-60	90-120
15"	20-25	50-60	90-120
16"	20-25	50-60	90-120

TRAILER GUIDELINES

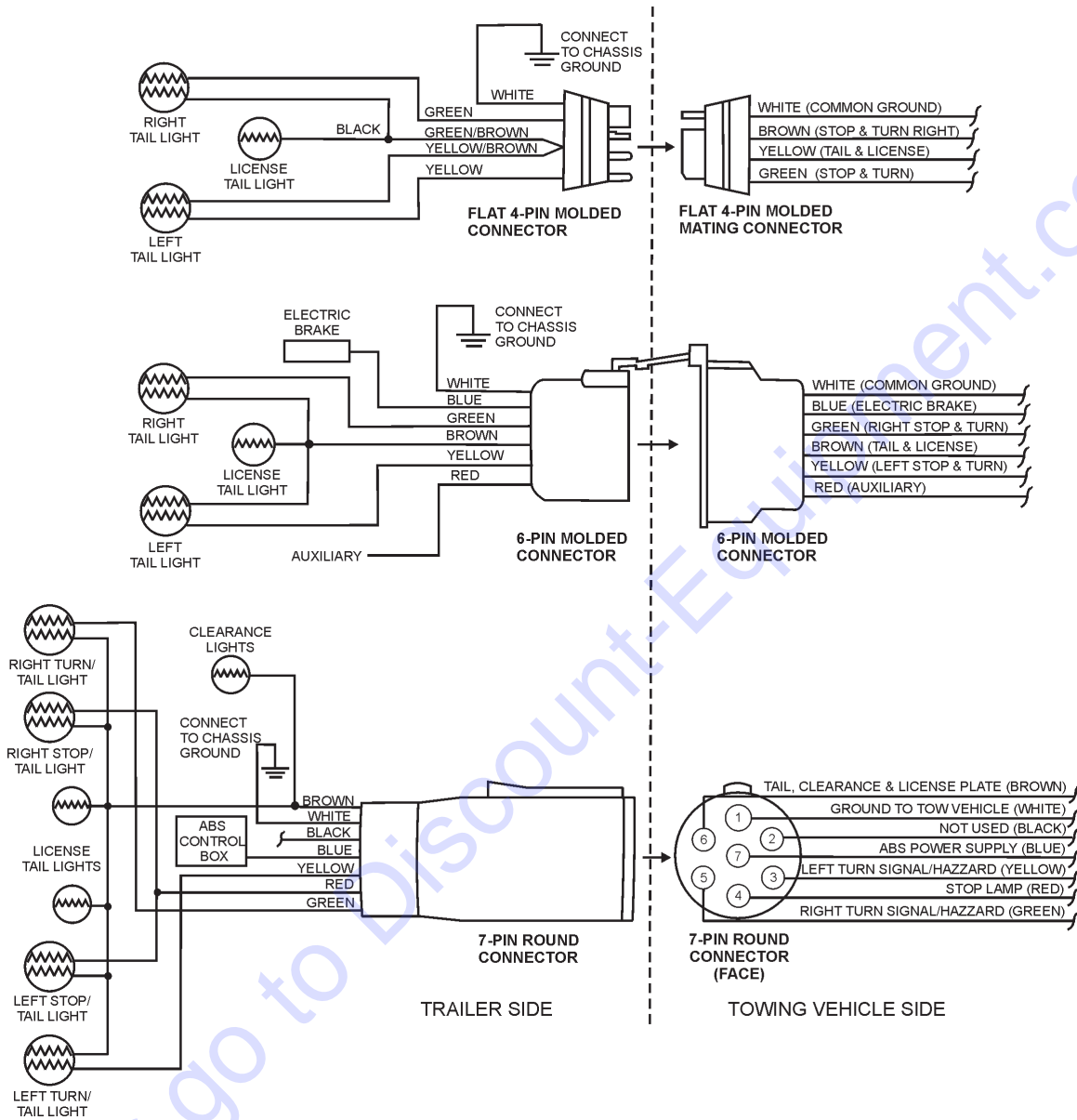


Figure J. Trailer to Tow Vehicle Wiring Diagram

TROUBLESHOOTING

Table 5. Troubleshooting (Pump)

Symptom	Possible Problem	Solution
Clutch slipping	Material pressure build up in manifold	Delivery system is plugged. Clear obstruction from manifold and/or delivery system
	Worn clutch friction lining or damaged springs	Replace clutch lining or rotor
	Manifold is packing with material, incorrect mix ratio	Verify correct mix ratio
	Worn balls and seats	Replace
V belt slippage	Loose V Belt	Adjust tension
Cam roller bearing does not ride on cam profile smoothly. "Knocks"	Insufficient back pressure	Too short delivery system, add more hose as necessary
	Manifold cavitation	Passing oversized aggregate through valve seats causing it to skip
	Broken spring	Replace spring
	Lubrication box has incorrect lubrication or low lubrication	Inspect fluid level. Verify using 30 weight motor oil
	Bent piston rod	Replace piston rod
	Restricted drive rod, piston rod connecting cross bolt too tight	Loosen piston rod cross bolt
Excessive lubrication box splash	Excessive oil	Overfilled. Reduce oil level
	Normal slurry buildup increasing oil level	Cleanout lubrication box
Broken chain links	Over-stressed	Remove delivery system blockage. Adjust excessive chain (slack) deflection
	Chain/sprockets out of alignment	Align chain/sprockets
Lubrication box has excessive concrete slurry	Material cups are worn	Replace material cups
	Material cylinders are damaged or worn beyond limit	Replace material cylinders
Material cylinder piston cups squeal	Incorrect lubrication	Verify using 30 weight motor oil
	Low on lubrication	Check fluid level
	Oil is not level in lubrication box	Level machine
Pump output is diminished (volcano effect in hopper)	Worn or dented balls and worn seats	Inspect and service balls and seats
	Material accumulation in manifold	Inspect and clean manifold
	Air entering T manifold	Replace "O" Rings
Radio remote has diminished range of operation	Low battery power	Replace battery
	Too many obstacles between pump and transmitter	Minimize signal obstructions
	Receiver and transmitter diminished communication	Go through synching process
Loss of speed control, stays at idle speed	Pump switch is not in the Pump ON position	Place pump switch in Pump ON position
	Hood is open	Close hood
	Faulty hood switch or wiring	Troubleshoot hood switch and wiring

TROUBLESHOOTING

Table 6. Troubleshooting (Diesel Engine)

Symptom	Possible Problem	Solution
Engine will not start or start is delayed, although engine can be turned over.	No Fuel reaching injection pump?	Add fuel. Check entire fuel system.
	Defective fuel pump?	Replace fuel pump.
	Fuel filter clogged?	Replace fuel filter and clean tank.
	Faulty fuel supply line?	Replace or repair fuel line.
	Compression too low?	Check piston, cylinder and valves. Adjust or repair per engine repair manual.
	Fuel pump not working correctly?	Repair or replace fuel pump.
	Oil pressure too low?	Check engine oil pressure.
	Low starting temperature limit exceeded?	Comply with cold starting instructions and proper oil viscosity.
	Defective battery?	Charge or replace battery.
	Air or water mixed in fuel system?	Check carefully for loosened fuel line coupling, loose cap nut, etc.
At low temperatures engine will not start.	Engine oil too thick?	Refill engine crankcase with correct type of oil for winter environment.
	Defective battery?	Replace battery.
Engine fires but stops soon as starter is switched off.	Fuel filter blocked?	Replace fuel filter.
	Fuel supply blocked?	Check the entire fuel system.
	Defective fuel pump?	Replace fuel pump.
Engine stops by itself during normal operation.	Fuel tank empty?	Add fuel.
	Fuel filter blocked?	Replace fuel filter.
	Defective fuel pump?	Replace fuel pump.
	Mechanical oil pressure shutdown sensor stops the engine due to low oil?	Add oil. Replace low oil shutdown sensor if necessary.
Low engine power, output and speed.	Fuel tank empty?	Replace fuel filter.
	Fuel filter clogged?	Replace fuel filter.
	Fuel tank venting is inadequate?	Ensure that tank is adequately vented.
	Leaks at pipe unions?	Check threaded pipe unions tape and tighten unions as required.
	Engine oil level too full?	Correct engine oil level.
	Injection pump wear?	Use No. 2-D diesel fuel only. Check the fuel injection pump element and delivery valve assembly and replace as necessary.

ENGINE FAULT CODES

MALFUNCTION INDICATOR DIAGNOSTIC SYSTEM

The C30HDGA concrete pump features an engine malfunction indicator lamp found on the control box (Figure 34). When a malfunction in the operation of the engine is detected, the orange check engine light will illuminate.

There are 2 methods of determining an engine malfunction. The first method is to connect a computer to the test port connector. The second method is to connect the blue/yellow wire from the control box to ground. Use the check engine indicator lamp on the control box to determine the error code. The indicator lamp will flash in sequence to indicate an error code. Use the Diagnostic Error Code Table (Table 7) to troubleshoot the malfunction.

The second method is explained below. The following steps use the MAP sensor as an **EXAMPLE** so that the user may become familiar with the troubleshooting process.

Example:

1. Open hood and disconnect MAP sensor connector. See Figure 33.

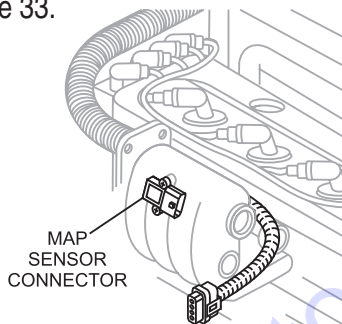


Figure 33. MAP Sensor Connector

2. Close hood and start engine. Let engine run for 3 to 5 minutes.
3. Verify that check engine warning lamp on the control box is on (lit). See Figure 34.

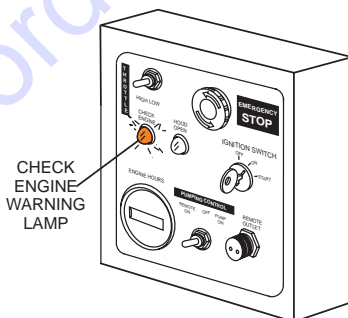


Figure 34. Engine Warning Lamp

4. If the check engine warning lamp is on, stop engine. Place ignition key in the OFF position. See Figure 35.

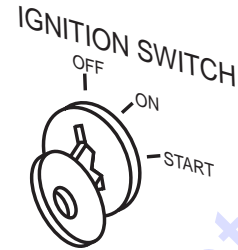


Figure 35. Ignition Key (Off)

5. Locate the brown and blue/yellow wires joined together at the back of the control box, tucked inside the split loom. Remove heat shrink covering the brown and blue/yellow wires (Figure 36).

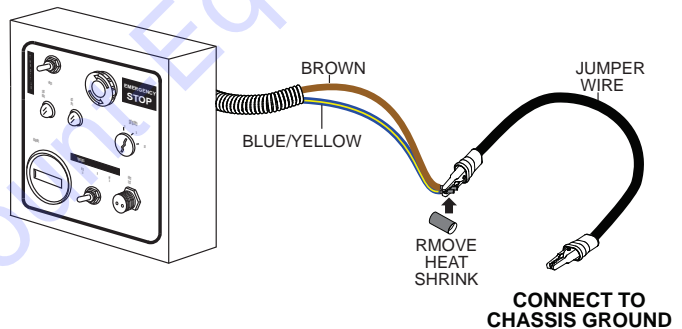


Figure 36. Ground Connection

6. Connect the brown and blue/yellow wires to chassis ground. See Figure 36.

ENGINE FAULT CODES

7. Close hood and place ignition key in the ON position. See Figure 37.

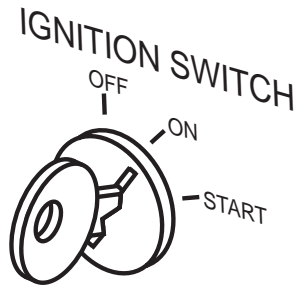


Figure 37. Ignition Key (On)

8. Observe check engine warning lamp flashing 3 consecutive times and repeating 3 times. This 1-1-1 sequence is defined as the leader code (Figure 38).

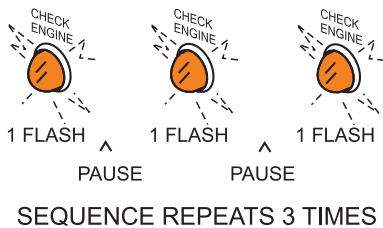


Figure 38. Leader Code

9. The check engine warning lamp will flash in 3 separate bursts as shown below. This sequence of lamp flashing represents the MIL flash error code (Figure 39). See Table 7 for a complete listing of error codes. In the MAP sensor example, the error code is 127.

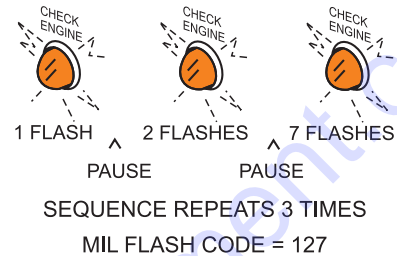


Figure 39. MIL Flash Error Code

10. To correct MAP sensor error, remove jumper wire, reconnect MAP sensor connector (See Figure 33) and restart engine. It may be necessary to restart and stop the engine five times in order to clear the error from the check engine warning lamp. Allow engine to run 3 to 5 minutes.
11. After error code has been corrected, insulate the end of the brown and blue/yellow wires with electrical tape.

ENGINE FAULT CODES

Table 7. GCP ECU Fault Code List for ZPP 416 Engine

NO.	FAULT DESCRIPTION	TURNS ON MIL?	MIL FLASH CODE
	Leader/Trailer Code		111
1	Lockoff open / ground short	Yes	6
2	Lockoff short to power	Yes	7
3	CRANK or CAM could not synchronize during start	Yes	216
4	MAP signal low or shorted to ground	Yes	127
5	MAP signal high	Yes	128
6	IAT signal Low/Shorted to GND	Yes	112
7	IAT signal High/Open	Yes	113
8	ECT higher than warning threshold	Yes	116
9	ECT Sensor Low/Shorted Input	Yes	117
10	ECT Sensor High/Open Input	Yes	118
11	TPS 1-2 voltage difference lower than expected	Yes	120
12	TPS 1-2 voltage difference higher than expected	Yes	121
13	Throttle Position Signal 1 low voltage	Yes	122
14	Throttle Position Signal 1 high voltage	Yes	123
15	Pre-Cat O2 Signal No Activity	Yes	134
16	Front O2 sensor heater control fault	Yes	135
17	Closed-loop LPG A/F is too lean	Yes	151
18	Closed-loop LPG A/F is too rich	Yes	152
19	Post-Cat O2 Signal No Activity	Yes	154
20	Closed-loop gasoline bank 1 A/F is too lean	Yes	155
21	Closed-loop gasoline bank 1 A/F is too rich	Yes	156
22	Catalyst inactive on LPG	Yes	165
23	Catalyst inactive on NG	Yes	166
24	Gasoline A/F is too lean (adaptive learn)	Yes	171
25	Gasoline A/F is too rich (adaptive learn)	Yes	172
26	Gasoline Fuel Temp Low Voltage	Yes	182
27	Gasoline Fuel Temp High Voltage	Yes	183
28	LPG Fuel Temp Low Voltage	Yes	187
29	LPG Fuel Temp High Voltage	Yes	188
30	Target TPS Lower than Actual	Yes	211
31	Target TPS Higher than Actual	Yes	212
32	ECT higher than engine shutdown threshold	Yes	217
33	Engine Overspeed Condition	Yes	219
34	TPS1 voltage higher than TPS2 voltage	Yes	221
35	Throttle Position Signal 2 low voltage	Yes	222
36	Throttle Position Signal 2 high voltage	Yes	223
37	Injector 1 Low/Open	Yes	261
38	Injector 1 High/Short	Yes	262

ENGINE FAULT CODES

Table 7. GCP ECU Fault Code List for ZPP 416 Engine (continued)

NO.	FAULT DESCRIPTION	TURNS ON MIL?	MIL FLASH CODE
39	Injector 2 Low/Open	Yes	264
40	Injector 2 High/Short	Yes	265
41	Injector 3 Low/Open	Yes	267
42	Injector 3 High/Short	Yes	268
43	Injector 4 Low/Open	Yes	269
44	Injector 4 High/Short	Yes	271
45	Injector 5 Low/Open	Yes	273
46	Injector 5 High/Short	Yes	274
47	Injector 6 Low/Open	Yes	276
48	Injector 6 High/Short	Yes	277
49	Gasoline Fuel Pressure too low	Yes	287
50	Gasoline Fuel Pressure too high	Yes	288
51	Gasoline Fuel Pressure low voltage	Yes	291
52	Gasoline Fuel Pressure high voltage	Yes	292
53	FPP1 higher than IVS limit	Yes	315
54	Knock Retard at Limit	Yes	325
55	Knock1/2 excessive signa	Yes	326
56	Knock1/2 sensor open	Yes	327
57	CRANK Sync Loss	Yes	335
58	CRANK signal noise	Yes	336
59	No CRANK signal	Yes	337
60	FPP1 lower than IVS limit	Yes	339
61	CAM signal noise	Yes	341
62	No CAM signal	Yes	342
63	Fuel (LPG or NG) run-out longer than expected	Yes	359
64	Primary Loop Open or Low-Side Short to Ground	Yes	411
65	Primary Coil Shorted	Yes	412
66	Catalyst inactive on gasoline	Yes	421
67	Engine Oil Pressure Too Low	Yes	524
68	Battery Voltage Low	Yes	562
69	Battery Voltage High	Yes	563
70	Microprocessor failure - FLASH	Yes	621
71	Microprocessor failure - RAM	Yes	624
72	Microprocessor failure - COP	Yes	626
73	Starter relay coil open	Yes	615
74	Starter relay control short to GND	Yes	616
75	Starter relay coil short to 12V	Yes	617
76	Gasoline fuel pump relay control wire open	Yes	627
77	Gasoline fuel pump relay control wire short to ground	Yes	628

ENGINE FAULT CODES

Table 7. GCP ECU Fault Code List for ZPP 416 Engine (continued)

NO.	FAULT DESCRIPTION	TURNS ON MIL?	MIL FLASH CODE
78	Gasoline fuel pump relay control wire short to 12 V	Yes	629
79	Pin 85 (AUX_PWM4) open/short to GND	Yes	637
80	5V Reference #1 voltage low	Yes	642
81	5V reference #1 voltage high	Yes	643
82	MIL control ground short	Yes	644
83	MIL control short to power	No	645
84	Malfunction Indicator Lamp open	Yes	651
85	5V Reference #2 voltage low	Yes	652
86	5V Reference #2 voltage high	Yes	653
87	Power relay coil open	Yes	685
88	Power relay short to GND	Yes	686
89	Power relay short to 12V	Yes	687
90	Secondary fuel pressure low	Yes	1087
91	Secondary fuel pressure high	Yes	1088
92	NG Closed-loop: A/F is too lean	Yes	153
93	NG Closed-loop: A/F is too rich	Yes	159
94	LPG Adaptive-learn: A/F is too lean	Yes	161
95	LPG Adaptive-learn: A/F is too rich	Yes	162
96	NG Adaptive-learn: A/F is too lean	Yes	163
97	NG Adaptive-learn: A/F is too rich	Yes	164
98	EPR delivery pressure higher than expected	Yes	371
99	EPR delivery pressure lower than expected	Yes	372
100	EPR-ECU communications lost	Yes	173
101	EPR voltage supply high	Yes	174
102	EPR voltage supply low	Yes	175
103	EPR internal actuator fault detected	Yes	176
104	EPR internal circuitry fault detected	Yes	177
105	EPR internal communications fault detected	Yes	178
106	EPR secondary pressure higher than expected	Yes	1271
107	EPR secondary pressure lower than expected	Yes	1272
108	EPR secondary comm lost	Yes	1273
109	EPR secondary voltage supply high	Yes	1274
110	EPR secondary voltage supply low	Yes	1275
111	EPR secondary internal actuator fault	Yes	1276
112	EPR secondary internal circuitry fault	Yes	1277
113	EPR secondary internal comm fault	Yes	1278
114	Spark Plug or Coil Failure	Yes	1351
115	AUX 5V ANALOG INPUT 4 open or high	No	515
116	AUX 5V ANALOG INPUT 4 low	No	516

ENGINE FAULT CODES

Table 7. GCP ECU Fault Code List for ZPP 416 Engine (continued)

NO.	FAULT DESCRIPTION	TURNS ON MIL?	MIL FLASH CODE
117	AUX 5V ANALOG INPUT 3 open or high	Yes	517
118	AUX 5V ANALOG INPUT 3 low	Yes	518
	AUX 5V ANALOG INPUT 1 high / Low Coolant Shutdown		
119	(On units Equipped)	Yes	541
120	AUX 5V ANALOG INPUT 1 low or open	Yes	542
121	AUX 5V ANALOG INPUT 2 high or open	Yes	543
122	AUX 5V ANALOG INPUT 2 low	Yes	544
123	AUX DIGITAL INPUT 1 high	Yes	551
124	AUX DIGITAL INPUT 1 low	Yes	552
125	AUX DIGITAL INPUT 2 high	Yes	553
126	AUX DIGITAL INPUT 2 low	Yes	554
127	AUX DIGITAL INPUT 3 high	Yes	555
128	AUX DIGITAL INPUT 3 low	Yes	556
129	AUX 5V ANALOG INPUT 5 open or high	Yes	563
130	AUX 5V ANALOG INPUT 5 low	Yes	564
131	Envirotech receipt lost	No	1601
132	Watchdog processor blocked outputs (RTI 1)	Yes	712
133	Microprocessor failure - RTI 2	Yes	713
134	Microprocessor failure - RTI 3	Yes	714
135	Microprocessor failure - A/D	Yes	715
136	Microprocessor failure - Interrupt	Yes	716
137	MIL control short to GND	No	644
138	MIL control short to 12V	No	645
139	Calibration Configuration Error	Yes	1673
140	Hardware ID Failure	Yes	1674
	Customer Auxiliary Shutdown #1 /		
141	Low coolant level shutdown (428, 644)	Yes	681
142	APP1 higher than IVS	Yes	315
143	APS/IVS Conflict	Yes	321
144	APP1 signal low voltage	Yes	322
145	APP1 signal high voltage	Yes	323
146	IVS stuck at idle, APP 1/2 mismatch	Yes	332
147	IVS stuck at off-idle, APP 1/2 mismatch	Yes	331
148	APP1 lower than IVS Limit	Yes	339
149	Secondary FP low voltage	Yes	2295
150	Secondary FP high voltage	Yes	2296

APPENDIX — CONCRETE MIX INFORMATION

CONCRETE MIX INFORMATION

The following information has been extracted from actual testing laboratory reports. The purpose of this printing is only to help create a better understanding of the importance of uniform gradation and proportioning of materials which affect pumpability of concrete mixes. These weights and proportions illustrate that when the sieve analysis is ideal, the sand/rock ratio can be adjusted (65% sand 35% rock) and pumpability should be excellent.

EXAMPLE #1 (A California Test Lab. Report)

JOB:	Building Foundations (Water Project)
Sacks per cu./yd.	6.5 designed for 2,500 lbs. in 28 days
Gallons per sack	7.1
Washed Sand-#200 wash	1.3
Organic matter	OK
Specific gravity (SSD)	Sand-2.58; Pea Gravel-2.60

SIEVE ANALYSIS-PERCENT PASSING

Material	1.5" 1"	3/4"	3/8"	#4	#8	#16	#30	#50	#100	#200
W.C. Sand			100	99.7	79.1	60.4	36.5	14.3	4.0	1.1
Pea Gravel			100	3.0						
% Comb.			100	66	51	39	23	9	3	1.0

DESIGN FOR ONE YARD OF CONCRETE (SATURATED & SURFACE DRY):

Absolute volume of aggregate in one cu. yard:	17.78 cu. ft.
Specific gravity of aggregates in one cu. yard:	2.58
Weight of aggregates in one cu. yard batch:	2850 lbs.

	<u>%</u>	<u>BATCH</u>	<u>SPEC. GRAVITY</u>	<u>ABS. VOL.</u>
W.C. Sand	65	1800	2.58	11.56
PEA GRAVEL	35	1000	2.60	6.22
WATER 46 gal.		1		
CEMENT 6.5 sk.		611		
TOTAL				27.00

ADMIXTURE: None













SLUMP 4"

REMARKS This mix is designed for pumping

NOTE: Due to the availability of well-graded sand as shown in the above sieve analysis, this mix pumped very successfully.

APPENDIX — CONCRETE MIX INFORMATION

A.S.T.M. STANDARD SPECIFICATION FOR GRADING AGGREGATE

SCREEN TYPE	U.S.	METRIC	PERCENTAGE PASSING BY WEIGHT
FINE AGGREGATE: Referred to as washed concrete sand.			
3/8" 	3/8"	9.50 mm	100%
#4 	4,760 microns	4.76 mm	95 to 100%
#8 	2,380 microns	2.38 mm	80 to 100%
#16 	1,190 microns	1.19 mm	50 to 85%
#30 	590 microns	.59 mm	50 to 85 %
#50 	297 microns	297µm	10 to 30%
#100 	149 microns	149µm	2 to 10%
3/8 (9.51 mm) PEA GRAVEL AGGREGATE: Referred to as #4 Rock or Gravel or 1/2" minus (12.7 mm) size			
1/2" 	1/2"	12.70 mm	100%
3/8" 	3/8"	9.51 mm	85 to 100%
#4 	4,760 microns	4.76 mm	10 to 30%
#8 	2,380 micron	2.38 mm	0 to 10%
#16 	1,190 microns	1.19 mm	0 to 5%

APPENDIX — CONCRETE MIX INFORMATION

SLUMP TEST PROCEDURE

1. To obtain a representative sample (concrete), take several samples at three or more regular intervals throughout the discharge of the mixer or truck. **DO NOT** take samples at the beginning or end of the discharge.
2. Dampen the inside of the cone and place it on a smooth, moist, non-absorbent, level surface large enough to accommodate both the slumped concrete and the slump cone. Stand on the “foot pieces” throughout the test procedure to hold the cone firmly in place.
3. Fill the cone 1/3 full by volume (Figure N) and rod 25 times with a 1/2” dia x 24” lg. bullet-pointed steel rod. (This is a specific requirement which will produce non-standard results unless followed exactly.) Distribute rodding evenly over the entire cross section of the sample.

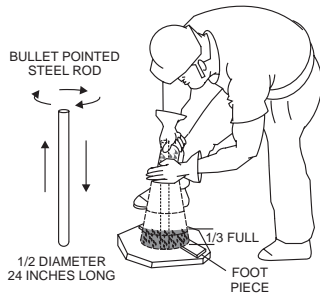


Figure N. Slump Test (1/3 Full)

4. Fill cone another 1/3 (Figure O) which will make the cone 2/3 full by volume. Rod this second layer 25 times with the rod penetrating into, but not through, the first layer. Distribute rodding evenly over the entire cross section of the layer.



Figure O. Slump Test (2/3 Full)

5. Fill cone to overflowing (Figure P). Rod this layer 25 times with rod penetrating into, but not through, the second layer. Distribute rodding evenly over the entire cross section of this layer.

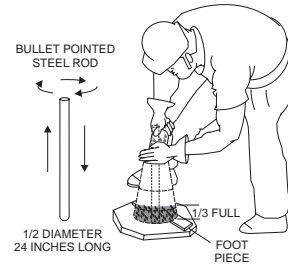


Figure P. Slump Test (Full-Overflow)

6. Remove the excess concrete (Figure Q) from the top of the cone, using the tamping rod as a screed.



Figure Q. Slump Test (Removing Excess Concrete)

7. Lift the cone vertically (Figure R) with a slow even motion. **DO NOT** jar the concrete or tilt the cone during this process. Invert the withdrawn cone, and place it next to, but not touching the slumped concrete.

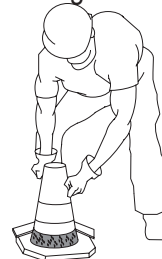


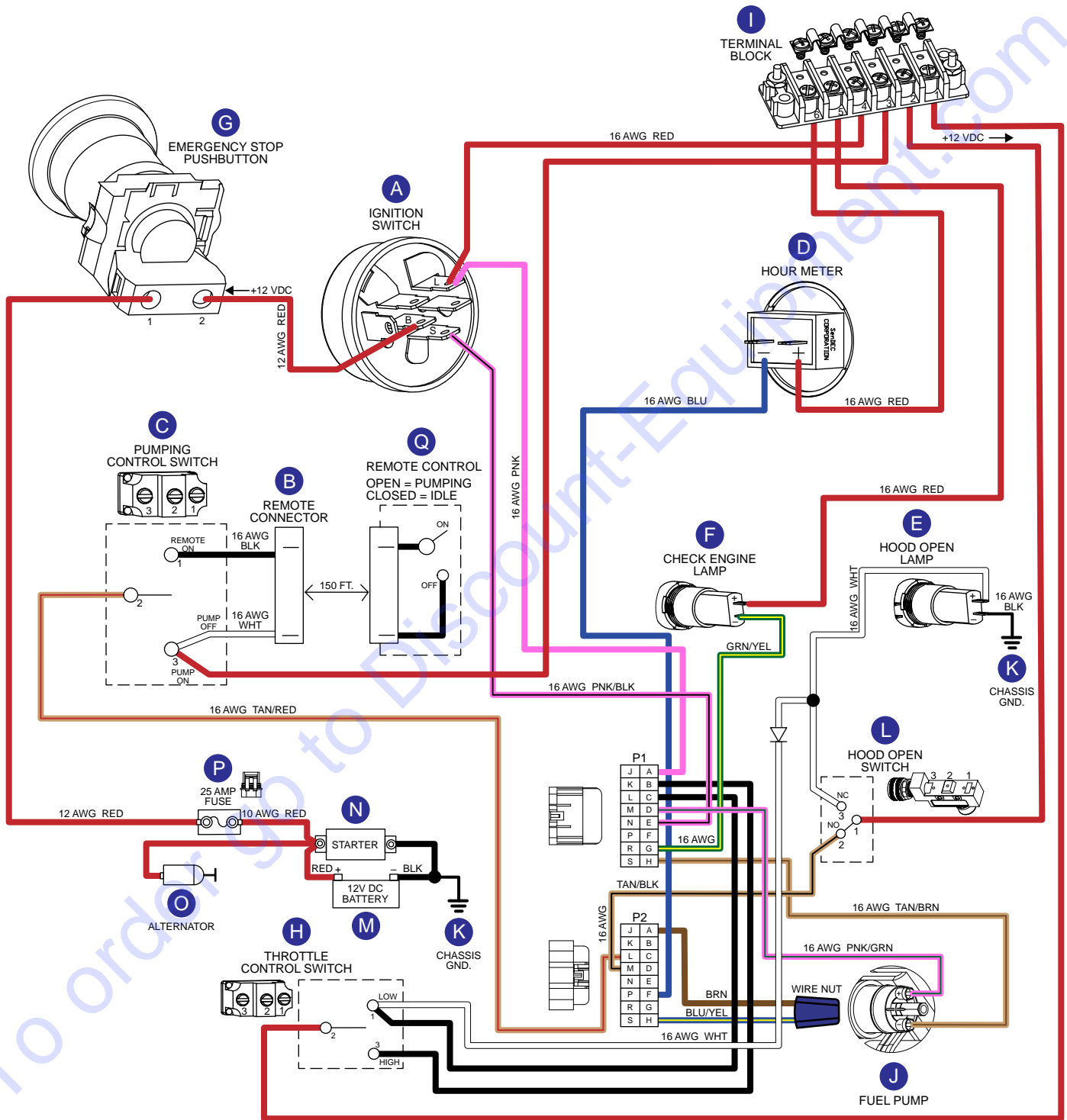
Figure R. Slump Test (Cone Invert)

8. Lay a straight edge (Figure S) across the top of the slumped cone. Measure the amount of slump in inches from the bottom of the straight edge to the top of the slumped concrete at a point over the original center of the base. The slump operation must be complete in a maximum elapsed time of 1-1/2 minutes. Discard the concrete. **DO NOT** use it in another test.

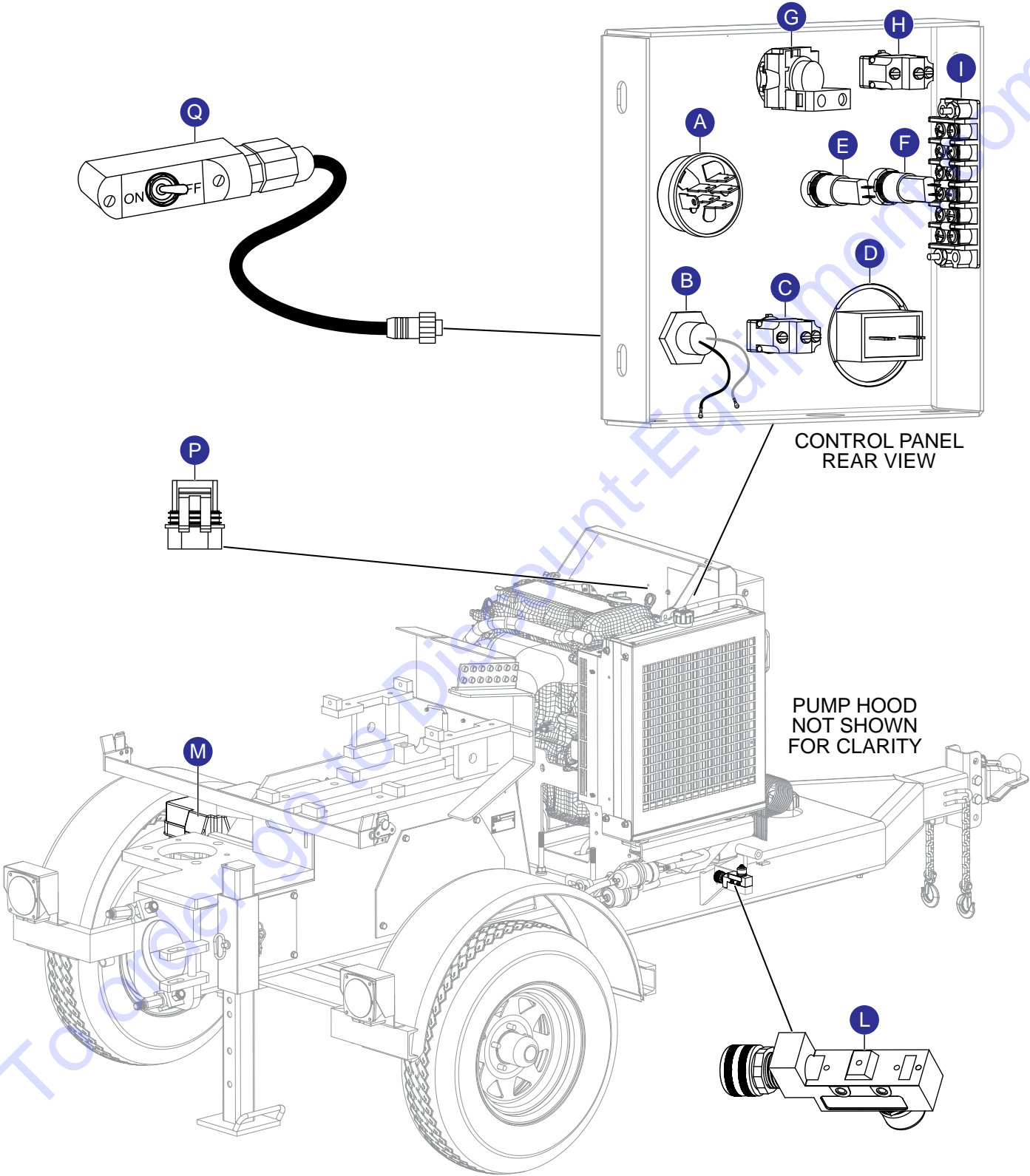


Figure S. Slump Test (Measurement)

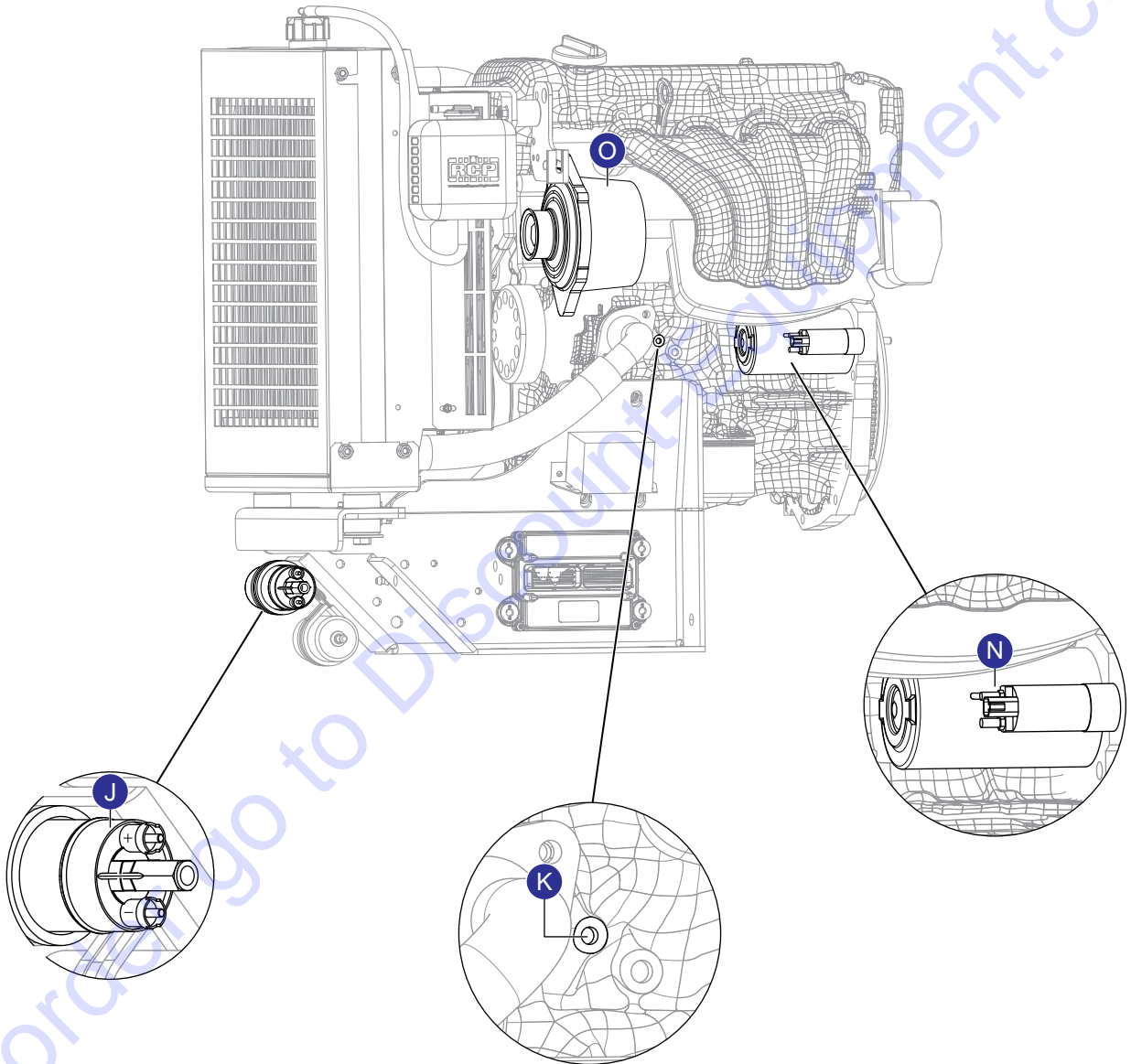
WIRING DIAGRAM (WIRING HARNESS)



ELECTRICAL COMPONENT LOCATOR



ELECTRICAL COMPONENT LOCATOR



TO PURCHASE THIS PRODUCT PLEASE CONTACT US



**Equipment Financing and
Extended Warranties Available**



**Discount-Equipment.com is your online resource for
commercial and industrial quality parts and equipment sales.**

561-964-4949

visit us on line @ www.discount-equipment.com

Select an option below to find your Equipment

Search by Manufacturer

Search by Product Type

Request a Quote

We sell worldwide for the brands: Genie, Terex, JLG, MultiQuip, Mikasa, Essick, Whiteman, Mayco, Toro Stone, Diamond Products, Generac Magnum, Airman, Haulotte, Barreto, Power Blanket, Nifty Lift, Atlas Copco, Chicago Pneumatic, Allmand, Miller Curber, Skyjack, Lull, Skytrak, Tsurumi, Husquvarna Target, Stow, Wacker, Sakai, Mi-T-M, Sullair, Basic, Dynapac, MBW, Weber, Bartell, Bennar Newman, Haulotte, Ditch Runner, Menegotti, Morrison, Contec, Buddy, Crown, Edco, Wyco, Bomag, Laymor, EZ Trench, Bil-Jax, F.S. Curtis, Gehl Pavers, Heli, Honda, ICS/PowerGrit, IHI, Partner, Imer, Clipper, MMD, Koshin, Rice, CH&E, General Equipment, Amida, Coleman, NAC, Gradall, Square Shooter, Kent, Stanley, Tamco, Toku, Hatz, Kohler, Robin, Wisconsin, Northrock, Oztec, Toker TK, Rol-Air, APT, Wylie, Ingersoll Rand / Doosan, Innovatech, Con X, Ammann, Mecalac, Makinex, Smith Surface Prep, Small Line, Wanco, Yanmar