

# PARTS MANUAL



 **MAYCO SERIES**  
**MODEL LS300P**  
**CONCRETE PUMP**  
**(PERKINS 404D-22TA DIESEL ENGINE)**

Revision #0 (03/22/17)



THIS MANUAL MUST ACCOMPANY THE EQUIPMENT AT ALL TIMES.

# PARTS FINDER

**Search Website  
by Part Number**



**Search Manual  
Library For Parts  
Manual & Lookup Part  
Numbers – Purchase  
or Request Quote**

**Search Manuals**

Enter your information to help us find the right parts manual for your machine.

\* Brand:

\* Model:

\* Serial:

\* Part Number:

SEARCH

**Can't Find Part or  
Manual? Request Help  
by Manufacturer,  
Model & Description**

**Parts Order Form**

Please fill in the following information to help us find the right part for your machine.

Manufacturer:	<input type="text"/>
Model:	<input type="text"/>
Description:	<input type="text"/>
Part Number:	<input type="text"/>
Quantity:	<input type="text"/>
Notes:	<input type="text"/>

Submit

Discount-Equipment.com is your online resource for quality parts & equipment.

Florida: **561-964-4949** Outside Florida TOLL FREE: **877-690-3101**

**Need parts?**

Click on this link: <http://www.discount-equipment.com/category/5443-parts/> and choose one of the options to help get the right parts and equipment you are looking for. Please have the machine model and serial number available in order to help us get you the correct parts. If you don't find the part on the website or on one of the online manuals, please fill out the request form and one of our experienced staff members will get back to you with a quote for the right part that your machine needs.

We sell worldwide for the brands: Genie, Terex, JLG, MultiQuip, Mikasa, Essick, Whiteman, Mayco, Toro Stone, Diamond Products, Generac Magnum, Airman, Haulotte, Barreto, Power Blanket, Nifty Lift, Atlas Copco, Chicago Pneumatic, Allmand, Miller Curber, Skyjack, Lull, Skytrak, Tsurumi, Husquvarna Target, Stow, Wacker, Sakai, Mi-T-M, Sullair, Basic, Dynapac, MBW, Weber, Bartell, Bennar Newman, Haulotte, Ditch Runner, Menegotti, Morrison, Contec, Buddy, Crown, Edco, Wyco, Bomag, Laymor, EZ Trench, Bil-Jax, F.S. Curtis, Gehl Pavers, Heli, Honda, ICS/PowerGrit, IHI, Partner, Imer, Clipper, MMD, Koshin, Rice, CH&E, General Equipment, Amida, Coleman, NAC, Gradall, Square Shooter, Kent, Stanley, Tamco, Toku, Hatz, Kohler, Robin, Wisconsin, Northrock, Oztec, Toker TK, Rol-Air, APT, Wylie, Ingersoll Rand / Doosan, Innovatech, Con X, Ammann, Mecalac, Makinex, Smith Surface Prep, Small Line, Wanco, Yanmar

# TABLE OF CONTENTS

## LS300P CONCRETE PUMP

Table Of Contents.....	2
Parts Ordering Procedures.....	3
Explanation Of Code In Remarks Column.....	4
Suggested Spare Parts .....	5

### Component Drawings

Nameplate And Decals Assembly .....	6-9
Frame Assembly .....	10-11
Axle/Brake Line Assembly.....	12-13
Trailer Hitch Assembly .....	14-15
Battery Assembly.....	16-17
Hopper Assembly .....	18-19
Hopper Attachment Assembly .....	20-21
Hopper Interior Assembly.....	22-23
Shuttle Cylinder Assembly.....	24-25
Lubrication Pistons Assembly.....	26-29
Fuel Tank Assembly.....	30-31
Heat Exchanger Assembly .....	32-33
Piston Accumulator Assembly .....	34-35
Lubrication Panel Assembly .....	36-37
Engine Cover Assembly .....	38-39
Hydraulic Tank Assembly.....	40-41
Engine Mounting Exhaust Assembly .....	42-43
Air Filter Assembly.....	44-45
Throttle Assembly.....	46-47
Fuel Filters/Water Separator Assembly .....	48-49
Hydraulic Pump Assembly.....	50-51
Manifold Assembly.....	52-53
Control Box Assembly .....	54-55
Control Box Harness Assembly.....	56-57
Remote Control Cable Assembly .....	58-59
Fuses And Relays Assembly.....	60-61
Terms And Conditions Of Sale — Parts .....	62

#### NOTICE

Specifications and part numbers are subject to change without notice.

# EXPLANATION OF CODE IN REMARKS COLUMN

The following section explains the different symbols and remarks used in the Parts section of this manual. Use the help numbers found on the back page of the manual if there are any questions.

## NOTICE

The contents and part numbers listed in the parts section are subject to change **without notice**. Multiquip does not guarantee the availability of the parts listed.

## SAMPLE PARTS LIST

NO.	PART NO.	PART NAME	QTY.	REMARKS
1	12345	BOLT .....	1	INCLUDES ITEMS W/%
2%		WASHER, 1/4 IN. ....		NOT SOLD SEPARATELY
2%	12347	WASHER, 3/8 IN. ...	1	MQ-45T ONLY
3	12348	HOSE .....	A/R	MAKE LOCALLY
4	12349	BEARING .....	1	S/N 2345B AND ABOVE

## NO. Column

**Unique Symbols** — All items with same unique symbol (@, #, +, %, or >) in the number column belong to the same assembly or kit, which is indicated by a note in the “Remarks” column.

**Duplicate Item Numbers** — Duplicate numbers indicate multiple part numbers, which are in effect for the same general item, such as different size saw blade guards in use or a part that has been updated on newer versions of the same machine.

## NOTICE

When ordering a part that has more than one item number listed, check the remarks column for help in determining the proper part to order.

## PART NO. Column

**Numbers Used** — Part numbers can be indicated by a number, a blank entry, or TBD.

TBD (To Be Determined) is generally used to show a part that has not been assigned a formal part number at the time of publication.

A blank entry generally indicates that the item is not sold separately or is not sold by Multiquip. Other entries will be clarified in the “Remarks” Column.

## QTY. Column

**Numbers Used** — Item quantity can be indicated by a number, a blank entry, or A/R.

A/R (As Required) is generally used for hoses or other parts that are sold in bulk and cut to length.

A blank entry generally indicates that the item is not sold separately. Other entries will be clarified in the “Remarks” Column.

## REMARKS Column

Some of the most common notes found in the “Remarks” Column are listed below. Other additional notes needed to describe the item can also be shown.

**Assembly/Kit** — All items on the parts list with the same unique symbol will be included when this item is purchased.

Indicated by:

“INCLUDES ITEMS W/(unique symbol)”

**Serial Number Break** — Used to list an effective serial number range where a particular part is used.

Indicated by:

“S/N XXXXX AND BELOW”

“S/N XXXX AND ABOVE”

“S/N XXXX TO S/N XXX”

**Specific Model Number Use** — Indicates that the part is used only with the specific model number or model number variant listed. It can also be used to show a part is NOT used on a specific model or model number variant.

Indicated by:

“XXXXX ONLY”

“NOT USED ON XXXX”

**“Make/Obtain Locally”** — Indicates that the part can be purchased at any hardware shop or made out of available items. Examples include battery cables, shims, and certain washers and nuts.

**“Not Sold Separately”** — Indicates that an item cannot be purchased as a separate item and is either part of an assembly/kit that can be purchased, or is not available for sale through Multiquip.

## SUGGESTED SPARE PARTS

### MAYCO SERIES LS300P CONCRETE PUMP

#### 1 TO 3 UNITS

Qty.	P/N	Description
3	802513	FILTER, FUEL IN-LINE
3	34505	FILTER, WATER SEPARATOR
2	EM98206K	KEY, IGNITION SWITCH
1	23284-300	FUSE, 30 AMP ATC/ATO
1	EM802378	RELAY, 40 AMP, FAN
1	EM802515	RELAY, 80 AMP, ENGINE PRE-HEAT
1	EM98163	SWITCH, PROXIMITY W/ CABLE
1	34507	FUEL CAP W/GAUGE
1	EM16462	RING AND FELT HOLDER
4	EM98050	CUP PISTON-ORANGE
4	EM16493	RING, FELT
2	EM14408	RING, BRONZE
2	EM16145A	BUSHING, SWING AXLE BRONZE
1	EM168161A	RING, ENERGIZER, RUBBER
1	EM168162	RING, STEEL, INSERT
2	EM98065	SEAL, GROOVED, RUBBER
1	EM98022	RING, WEAR
4	EM14407	O-RING, OILER PLATE
1	EM98021A	WEAR PLATE
2	EM517700	O-RING, WEAR PLATE
1	EM98033	OILER PLATE W/HOLES

### PERKINS 404D-22TA DIESEL ENGINE

#### 1 to 3 units

Qty.	P/N	Description
3	2654407	OIL FILTER
3	62510380	AIR FILTER
3	26560201	FILTER, FUEL/WATER SEPARATOR
1	2656F837	BOWL, PLASTIC FUEL/WATER SEPARATOR

#### NOTICE

Part numbers on this Suggested Spare Parts list may supersede/replace the part numbers shown in the following parts lists.



## NAMEPLATE AND DECALS ASSEMBLY

<u>NO.</u>	<u>PART NO.</u>	<u>PART NAME</u>	<u>QTY.</u>	<u>REMARKS</u>
1	803810	DECAL, FUSE/RELAY OVERLAY	1	
2	EM516936	DECAL, MQ/MAYCO LS300 LOGO LARGE	1	
3	34627	DECAL, TOWING, WARNING	1	
4	DCL305	DECAL, WARNING REAR STABILIZERS	1	
5	513580	DECAL, ENGINE RPM SETTING	1	
6	EM980	DECAL, THROTTLE	1	
7	EM985	DECAL, VOLUME CONTROL	1	
8	EM97084	DECAL, MAINTENANCE	1	
9	DCL300	DECAL, LUBRICATION BOX	1	
10	517907	DIGITAL CONTROL PANEL LOGO	1	
11\$	EM97070	DECAL, PUMPING PRESSURE	1	
12	35137	DECAL, CAUTION READ MANUAL	1	
13	EM97072	DECAL, CAUTION OPERATIONS INSTRUCT.	1	
14	EM511901	DECAL, CAUTION MINIMUM OIL LEVEL	1	
15	EM985	DECAL, HYDRAULIC OIL	1	

Go to Discount-Equipment.com to order your parts





## NAMEPLATE AND DECALS ASSEMBLY

<u>NO.</u>	<u>PART NO.</u>	<u>PART NAME</u>	<u>QTY.</u>	<u>REMARKS</u>
1	EM97083	DECAL; WARNING	1	
2	EM955	DECAL; CAUTION DRY NITROGEN	1	
3	EM995	DECAL; CAUTION DIESEL FUEL	1	
4	516937	DECAL; MAYCO LOGO SMALL	1	
5	DCL304	DECAL; DANGER IMPROPER CHARGING	1	
6	DCL302	DECAL; WARNING BURN HAZARD	1	
7	518524	DECAL; ISO 9001:2008 EXPORT	1	
8	34536	DECAL; OWNER'S MANUAL	1	
9	EM969	DECAL; CAUTION TOWING	1	
10	DCL301	DECAL; DANGER SHUTTLE TUBE	2	
11	EM97072	DECAL; CAUTION OPERATIONS INSTRUCT.	1	
12	EM511709	DECAL; 800-30-MAYCO	1	
13	EM510386	DECAL; CAUTION-GREASE 2 HOURS	2	

Go to Discount-Equipment.com to order your parts

# FRAME ASSEMBLY

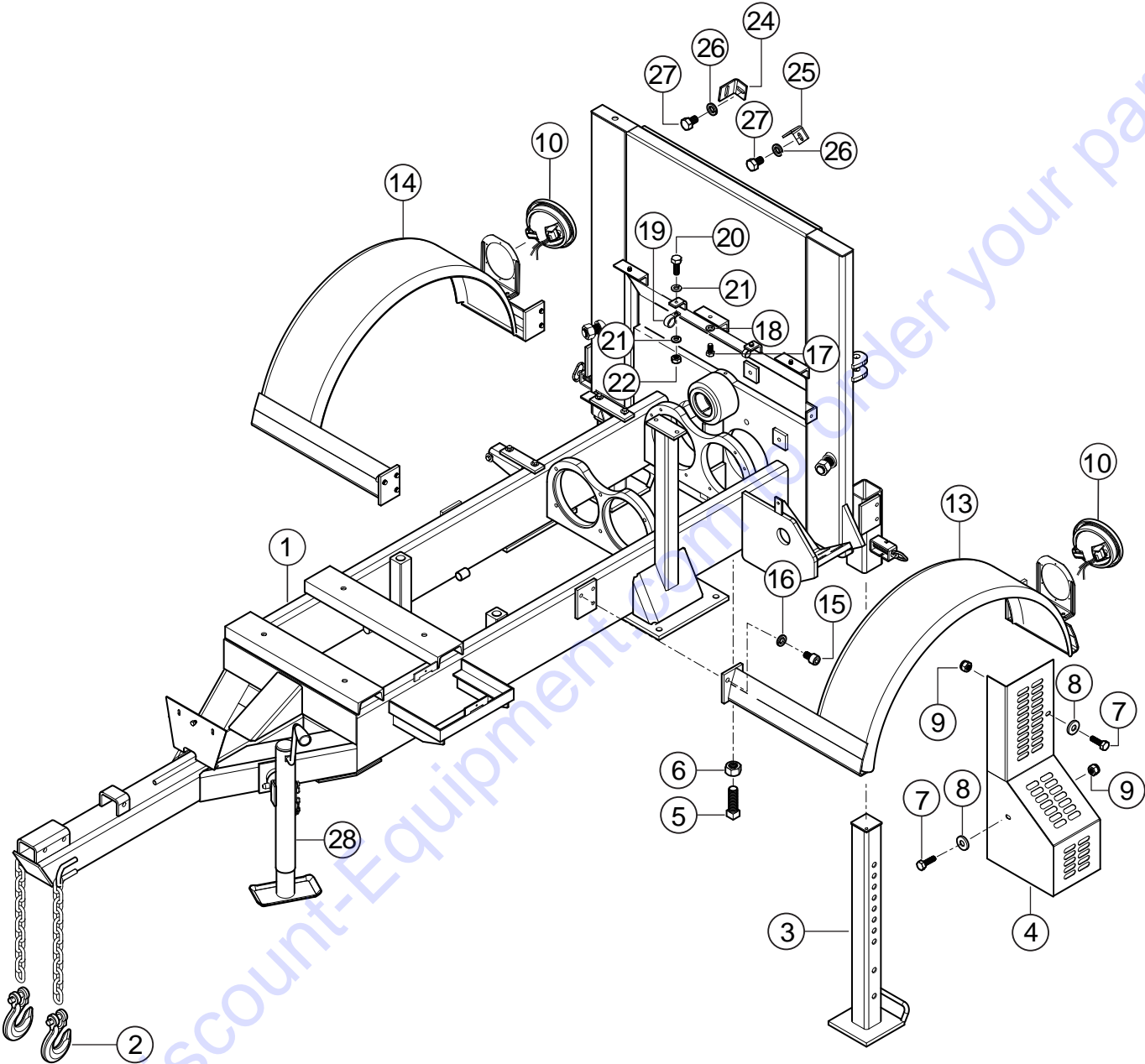

## FRAME ASSEMBLY

<u>NO.</u>	<u>PART NO.</u>	<u>PART NAME</u>	<u>QTY.</u>	<u>REMARKS</u>
1	803684	FRAME, MAIN	1	
2	516581	SAFETY HOOK W/LATCH 1/2"	2	
3	EM70186	JACK STAND, FRONT	2	
4	EM517742	GUARD, SHUTTLE CYLINDER	1	
5	492491	SCREW SET	1	
6	6109160	NUT, HEX 1/2" DIA. NC .....	3	REPLACES P/N 492556
7	0202	SCREW, HHC 5/16" X 18" X 1" .....	10	REPLACES P/N 492364
8	EM923023	WASHER, FLAT 5/16" .....	12	REPLACES P/N 492597
9	2105164	NUT, NYLON 5/16"-18 .....	6	REPLACES P/N 492582
10	EM26536	LIGHT, TAIL, BRAKE	2	
13	518025	FENDER WHEEL, RIGHT	1	
14	518026	FENDER WHEEL, LEFT	1	
15	803692	BOLT, 1/2" X 3/4" NC GRD. 5	10	
16	6109180	WASHER, LOCK 1/2" DIA. ....	10	REPLACES P/N 492626
17	EM963055	BOLT, 3/8" DIA. ....	3	REPLACES P/N 492373
18	0166 A	WASHER, LOCK 3/8" DIA. ....	3	REPLACES P/N 492624
19	801130	CLAMP HOSE	2	
20	492356	BOLT, 1/4" X 3/4"	2	
21	2101402	WASHER, LOCK 1/4" DIA. ....	4	REPLACES P/N 492622
22	2101428	NUT, HEX 1/4"-20 .....	2	REPLACES P/N 492561
24	517860	SUPERIOR SENSORS SUPPORT	1	
25	517861	LOWER SENSORS SUPPORT	1	
26	6109180	WASHER, LOCK 1/2" DIA. ....	2	REPLACES P/N 492626
27	EM504456	BOLT, 1/2"-13 X 3/4" HEX GRD. 8	2	
28	EM25610	JACKSTAND, SWIVEL TRAILER	1	

# AXLE/BRAKE LINE ASSEMBLY

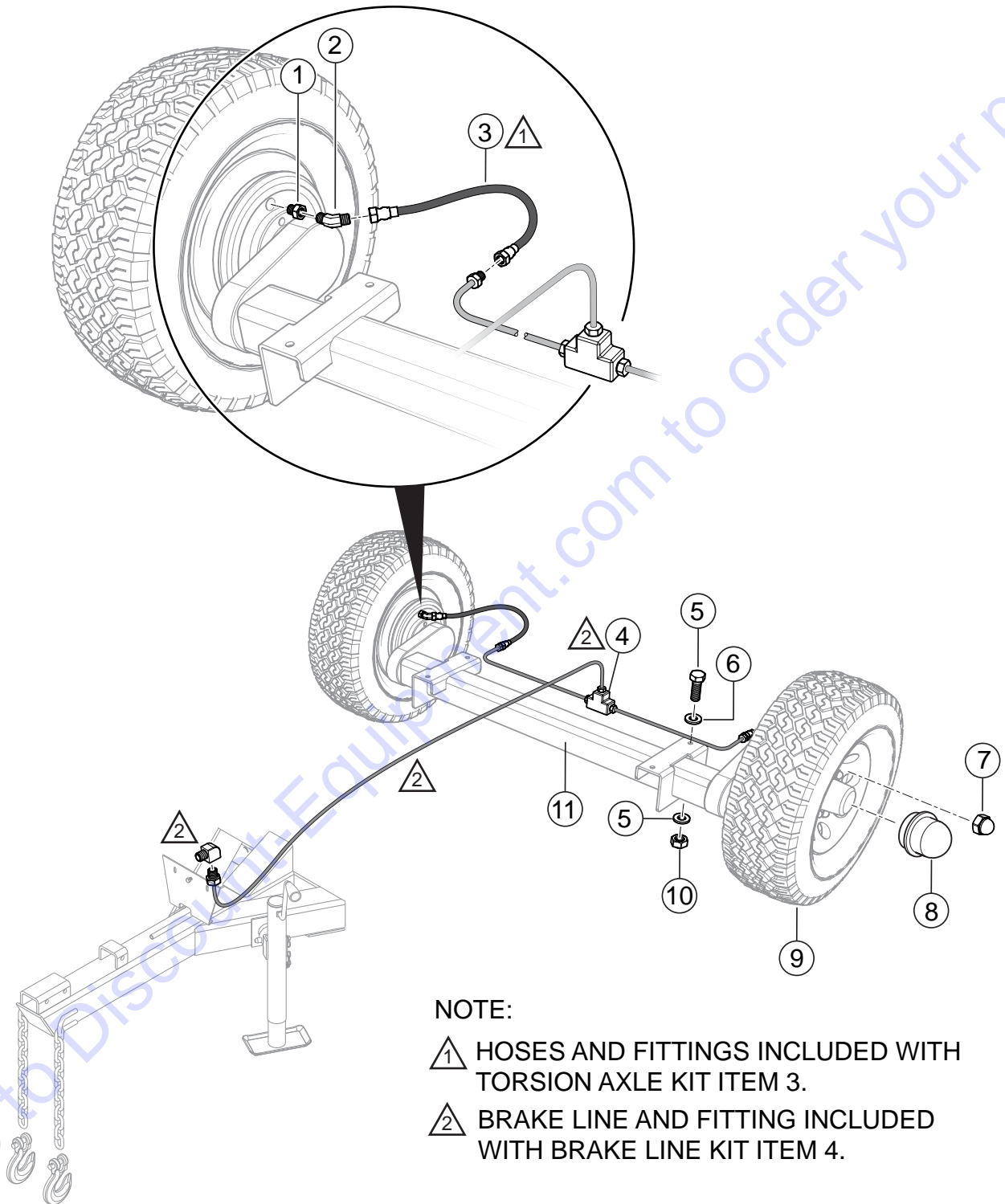

**NOTE:**

- △ 1 HOSES AND FITTINGS INCLUDED WITH TORSION AXLE KIT ITEM 3.
- △ 2 BRAKE LINE AND FITTING INCLUDED WITH BRAKE LINE KIT ITEM 4.

## AXLE/BRAKE LINE ASSEMBLY

<u>NO.</u>	<u>PART NO.</u>	<u>PART NAME</u>	<u>QTY.</u>	<u>REMARKS</u>
1	EM512877	ADAPTER, STRAIGHT	2	
2	EM512876	ADAPTER, ELBOW	2	
3	34566	KIT, TORSION AXLE	1	
4	34565	KIT, HYDRAULIC BRAKE LINE	1	
5	EM963692	BOLT, 1/2" X 1-1/2" UNC .....	4.....	REPLACES P/N 492394
6	EM621	WASHER, 1/2" SPECIAL	8	
7	EM26519	NUT, LUG CHROME	12	
8	EM26520	CAP 15" CHROME	2	
9	516479	WHEEL, TIRE/RIM	2	
10	6109160	NUT, HEX 1/2" DIA. NC .....	4.....	REPLACES P/N 492556
11	EM516931	AXLE ASSEMBLY	1	

Go to Discount-Equipment.com to order your parts

# TRAILER HITCH ASSEMBLY

## OPTIONAL TOW RING

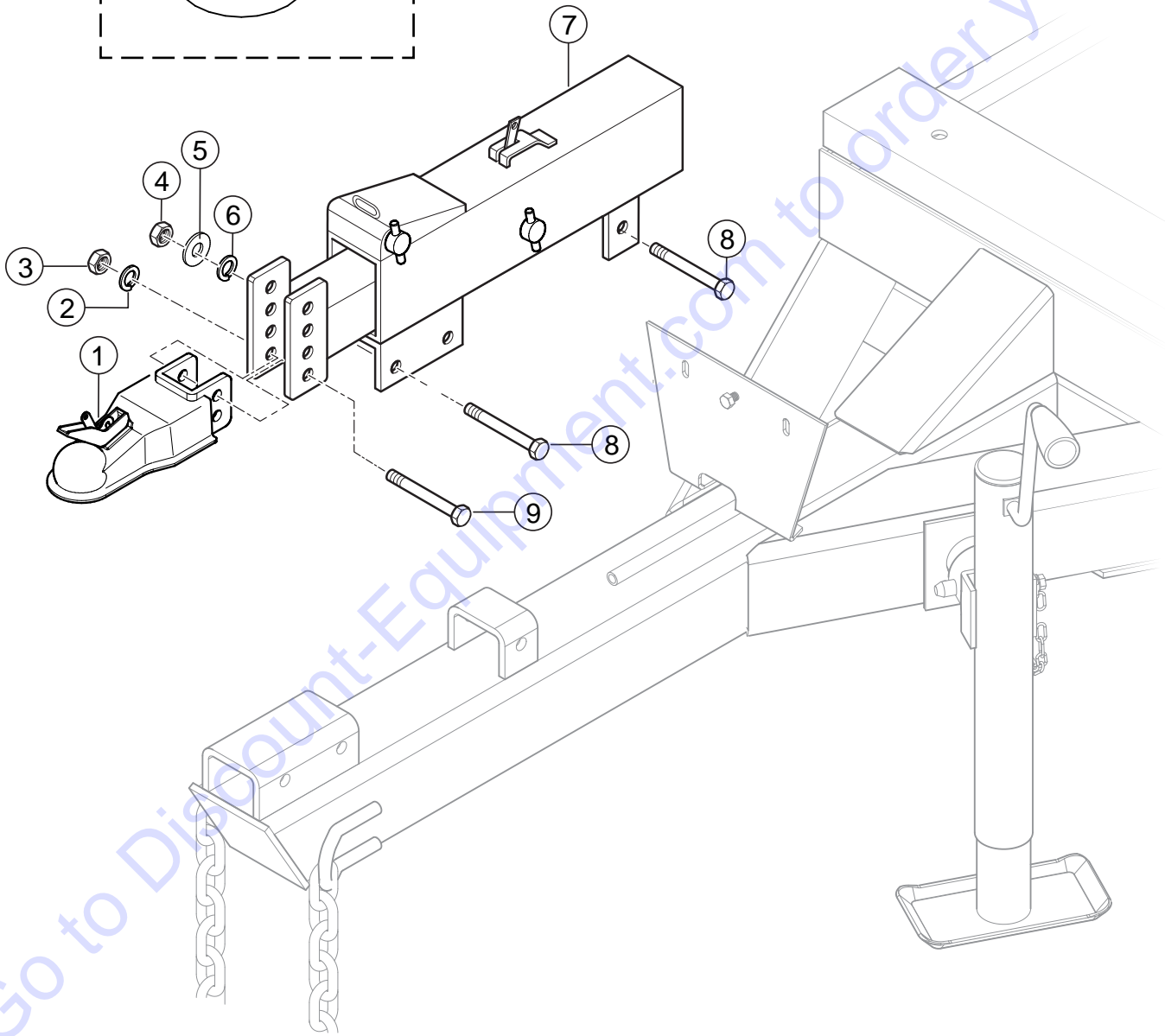
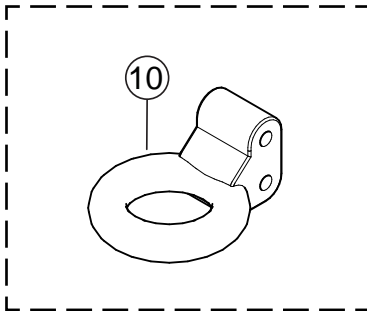

## TRAILER HITCH ASSEMBLY

<u>NO.</u>	<u>PART NO.</u>	<u>PART NAME</u>	<u>QTY.</u>	<u>REMARKS</u>
1	29228	BALL COUPLER, 2" ADJUSTABLE, 8000#	1	
2	EM923348	WASHER, LOCK 5/8" DIA. ....	2.....	REPLACES P/N 492627
3	EM968013	NUT, 5/8" DIA. NC GRD. 5 .....	2.....	REPLACES P/N 492557
4	6109160	NUT, HEX 1/2" DIA. NC .....	3.....	REPLACES P/N 492556
5	6109170	WASHER, FLAT 1/2" DIA.....	3.....	REPLACES P/N 492600
6	6109180	WASHER, LOCK 1/2" DIA. ....	3.....	REPLACES P/N 492626
7	19067	ACTUATOR, BRAKE	1	
8	518257	BOLT, HEX HD 1/2" X 4-1/2" NC GRD. 8	3	
9	518256	BOLT, HEX HD 5/8" X 4-1/2" NC GRD. 8	2	
10	29369	COUPLER, 3" PINTLE EYE, 14,000 LBS.....	1.....	OPTION

Go to Discount-Equipment.com to order your parts

# BATTERY ASSEMBLY

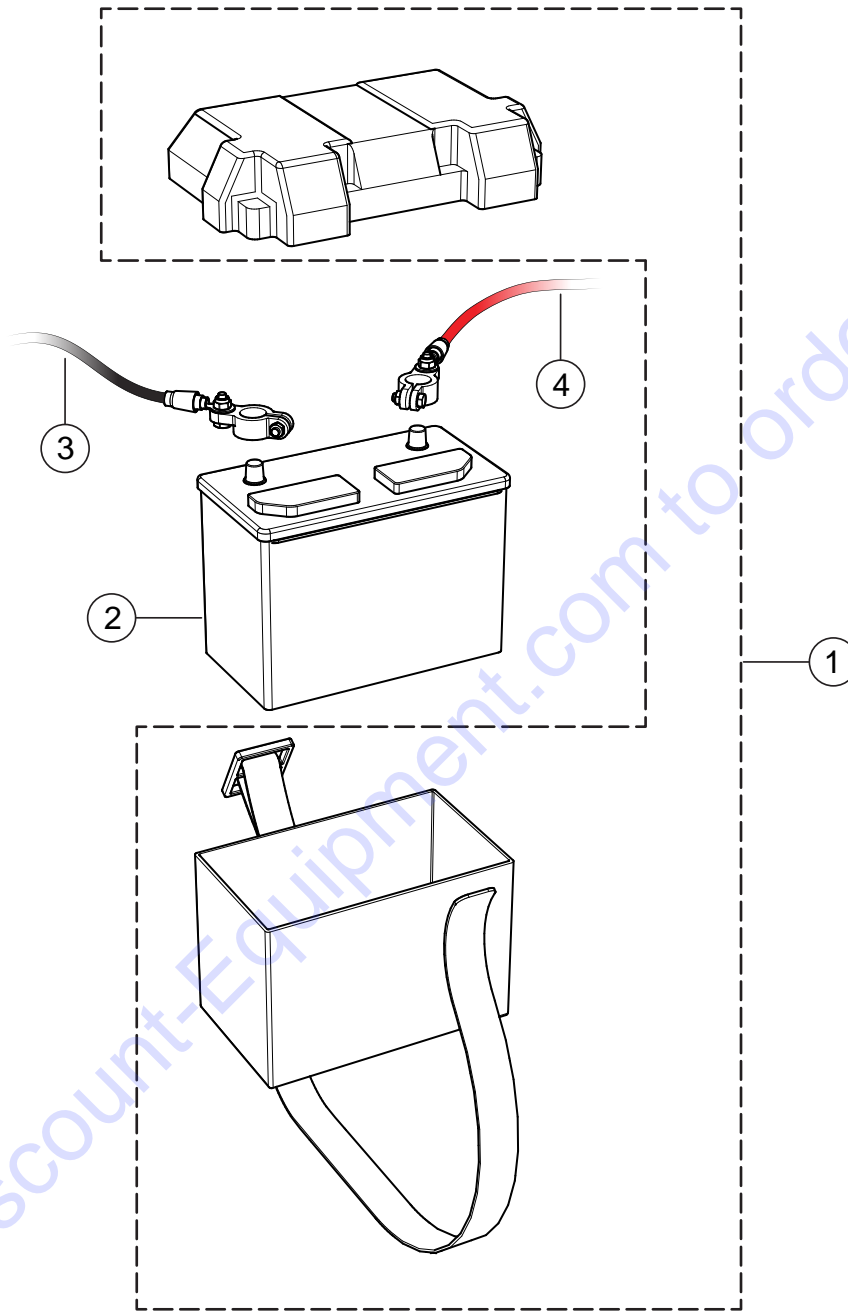



## BATTERY ASSEMBLY

---

<u>NO.</u>	<u>PART NO.</u>	<u>PART NAME</u>	<u>QTY.</u>	<u>REMARKS</u>
1	10318	BATTERY BOX W/BELT	1	
2	520520	BATTERY 12V.....	1.....	OBTAIN LOCALLY
3	515118	BATTERY CABLE, NEGATIVE	1	
4	804039	BATTERY CABLE, POSITIVE	1	

Go to Discount-Equipment.com to order your parts

# HOPPER ASSEMBLY

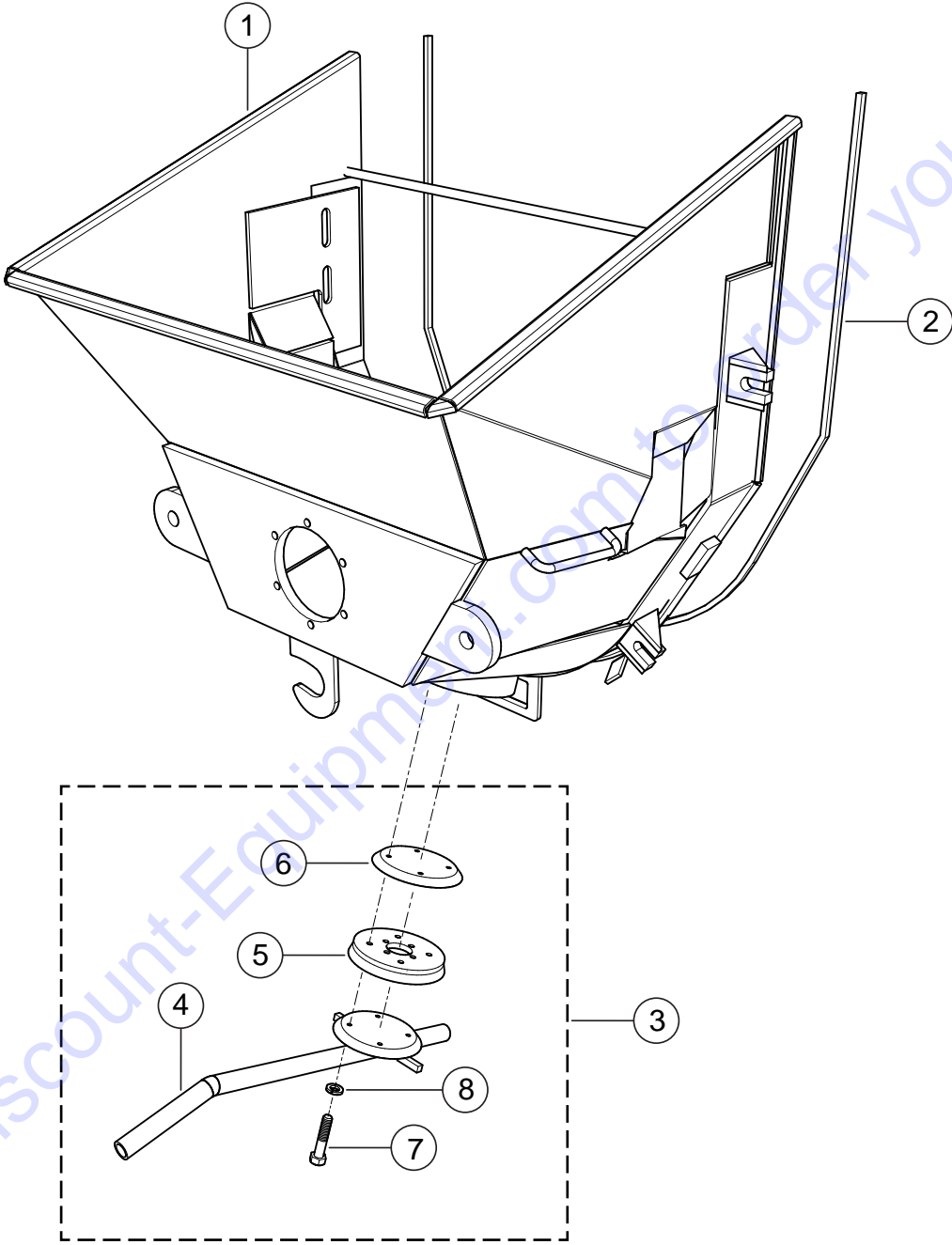

# HOPPER ASSEMBLY

<u>NO.</u>	<u>PART NO.</u>	<u>PART NAME</u>	<u>QTY.</u>	<u>REMARKS</u>
1	EM517753	HOPPER ASSEMBLY	1	
2	EM16184	SEAL HOPPER 3/8" X 1/2"	1	
3	EM70860	HOPPER CLEANOUT PLUG ASSEMBLY	1	INCLUDES ITEMS W/\$
4\$	EM508830	HANDLE	1	
5\$	EM50417	CUP SPECIAL	1	
6\$	EM708601	PISTON CUP HOLDER	1	
7\$	492378	BOLT, HHCS GRD. 5	4	
8\$	0166 A	WASHER, LOCK 3/8" DIA.	4	REPLACES P/N 492624

Go to Discount-Equipment.com to order your parts

# HOPPER ATTACHMENT ASSEMBLY

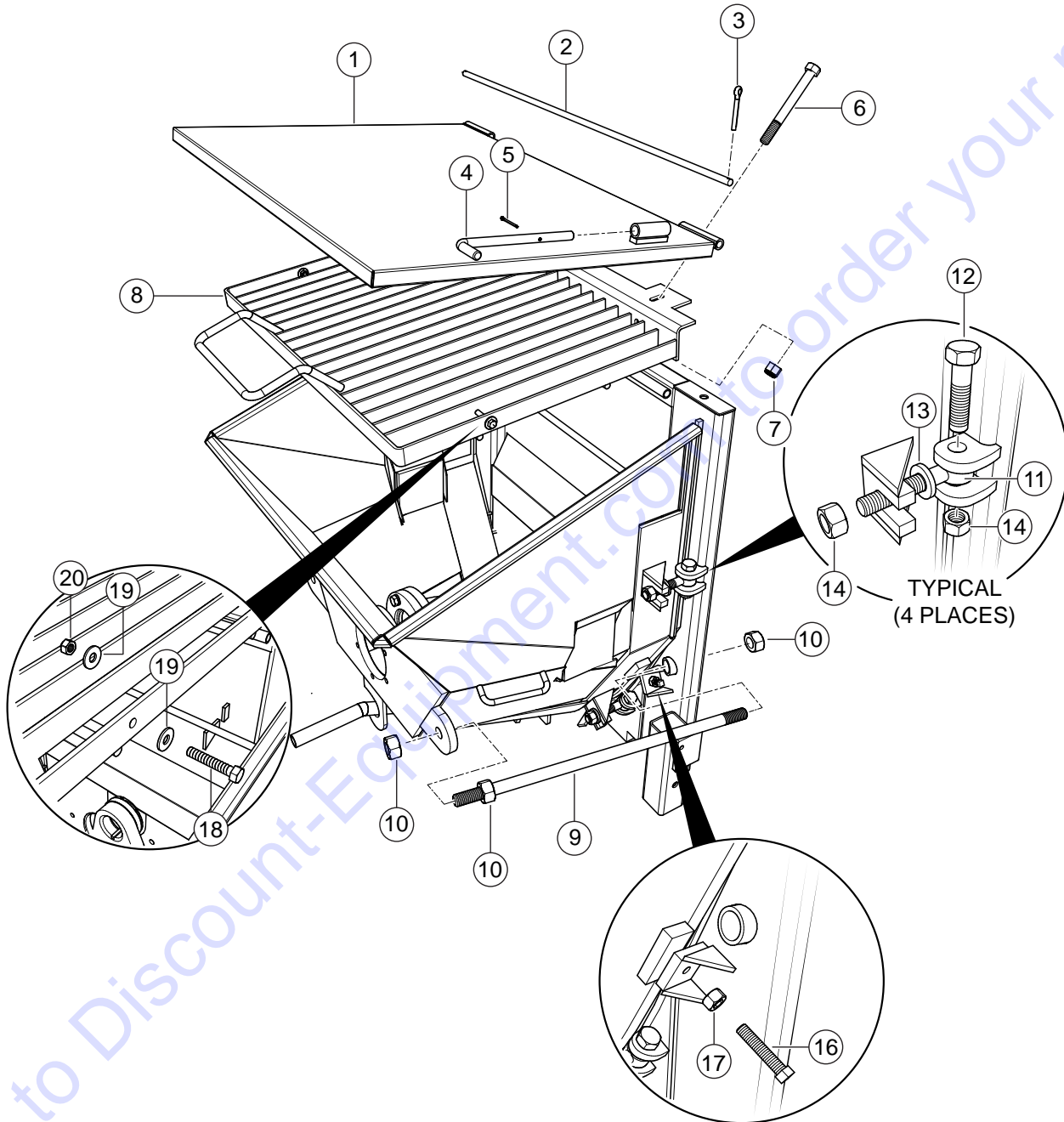

## HOPPER ATTACHMENT ASSEMBLY

<u>NO.</u>	<u>PART NO.</u>	<u>PART NAME</u>	<u>QTY.</u>	<u>REMARKS</u>
1	EM514204	COVER SPLASH .....	1.....	REPLACES P/N 514204
2	EM514620	PIN, HINGE.....	1.....	REPLACES P/N 514620
3	EM491686	PIN, COTTER .....	2.....	REPLACES P/N 491686
4	EM70134-2	PIN, SPLASH PLATE	1	
5	EM505723	PIN, COTTER 5/32" X 1-1/2" .....	1.....	REPLACES P/N 505723
6	515395	BOLT, 7/16" X 4" NC GRD. 5	2	
7	505081	NUT HEX 7/16"	2	
8	EM514357	GRATE	1	
9	EM16166	TIE ROD	2	
10	EM424	NUT HEX 1" NC.....	6.....	REPLACES P/N 505728
11	EM14165	BOLT EYE	4	
12	505121	BOLT 3/4" X 3"	4	
13	EM619	WASHER 3/4"	4	
14	EM968446	NUT HEX 3/4" .....	8.....	REPLACES P/N 492558
16	505123	BOLT HEX 1/2" X 2-1/2"	2	
17	6109160	NUT HEX 1/2".....	2.....	REPLACES P/N 492556
18	492379	SCREW CAP 3/8"	2	
19	3019092	WASHER, FLAT 3/8" .....	4.....	REPLACES P/N 492598
20	EM969013	NUT, NYLOC.....	2.....	REPLACES P/N 492583

Go to Discount-Equipment.com to order your parts

# HOPPER INTERIOR ASSEMBLY

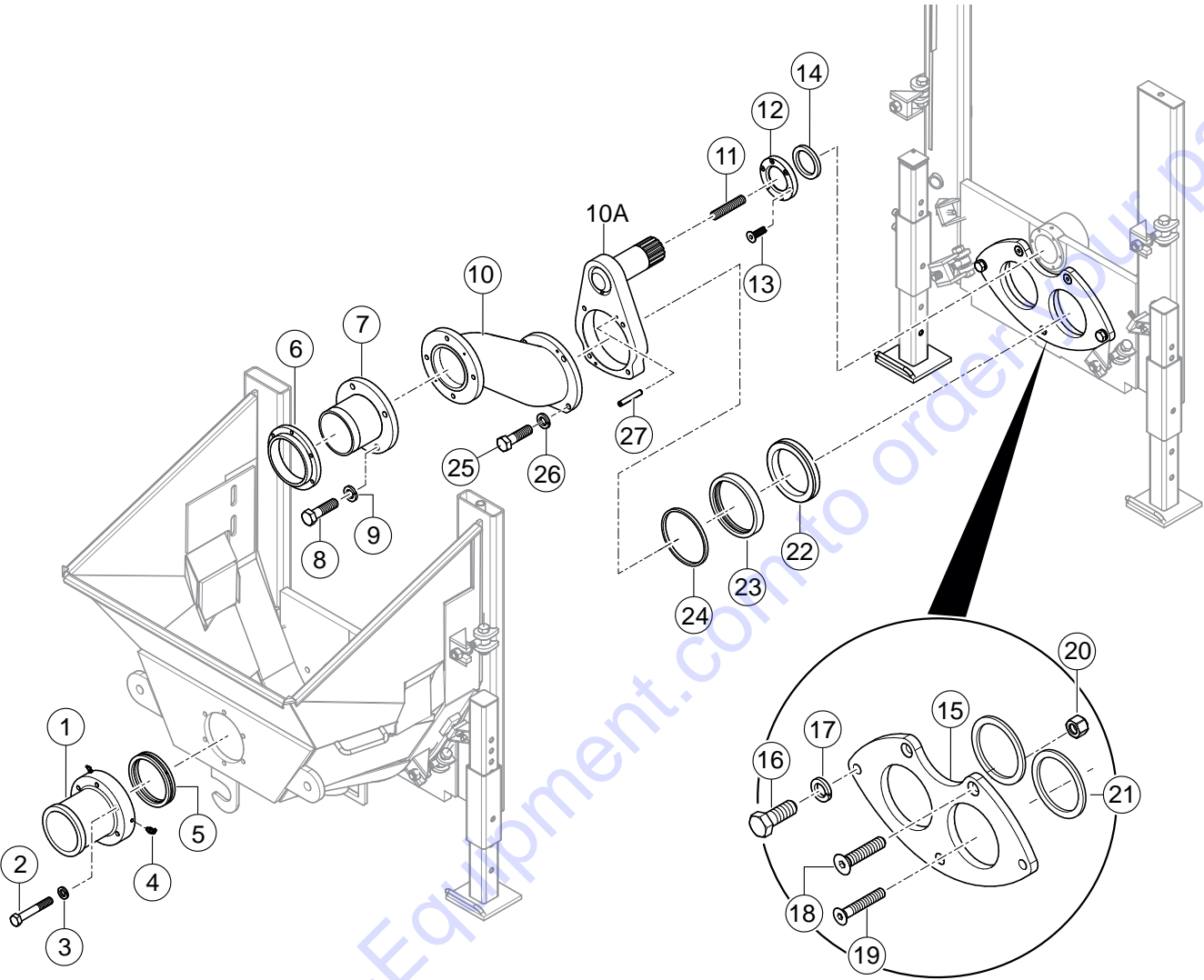

## HOPPER INTERIOR ASSEMBLY

<u>NO.</u>	<u>PART NO.</u>	<u>PART NAME</u>	<u>QTY.</u>	<u>REMARKS</u>
1	EM512212	DISCHARGE NIPPLE	1	
2	EM210	BOLT, HEX HEAD	6	
3	6109180	WASHER, LOCK 1/2" DIA. ....	6.....	REPLACES P/N 492626
4	491701	GREASE FITTING	3	
5	EM98065	GROOVED SEAL	1	
6	EM25803	BEARING, DISCHARGE PLATE	1	
7	EM16804	SLEEVE, 5"	1	
8	EM104	BOLT, HEX HEAD 5/8"-11 X 2" .....	4.....	REPLACES P/N 503982
9	EM923348	WASHER, LOCK 5/8" .....	4.....	REPLACES P/N 492627
10	EM25843	NUN PLATE	1	
10A	EM16811	SHUTTLE CYLINDER	1	
11	EM284	STUD, 1"-14 X 5" GRD. 8	1	
12	800427	RETAINER PLATE	1	
13	506176	BOLT, 5/16"-18 X 1" FHAS	6	
14	800426	RUBBER SEAL	1	
15	EM98021A	PLATE WEAR, ONE SIDED.....	1.....	REPLACES P/N EM98021
16	EM151	HHCS 3/4" X 2 GRD. 5.....	2.....	REPLACES P/N 509078
17	492628	WASHER, LOCK 3/4"	2	
18	EM265	BOLT, 5/8"-11 X 3" COUNTERSUNK	2	
19	EM264	BOLT, 1/2"-13 X 3" COUNTERSUNK	1	
20	EM969023	NUT, LOCK 5/8" .....	2.....	REPLACES P/N 492586
21	EM517700	O-RING	2	
22	EM98022	WEAR RING H/F	1	
23	EM168161A	RING, ENERGIZER RUBBER	1	
24	EM168162	RING, INSERT STEEL	1	
25	EM104	BOLT, HEX HD 5/8" X 2"	4	
26	EM923348	WASHER, LOCK 5/8"	4	
27	419719	PIN	1	

# SHUTTLE CYLINDER ASSEMBLY

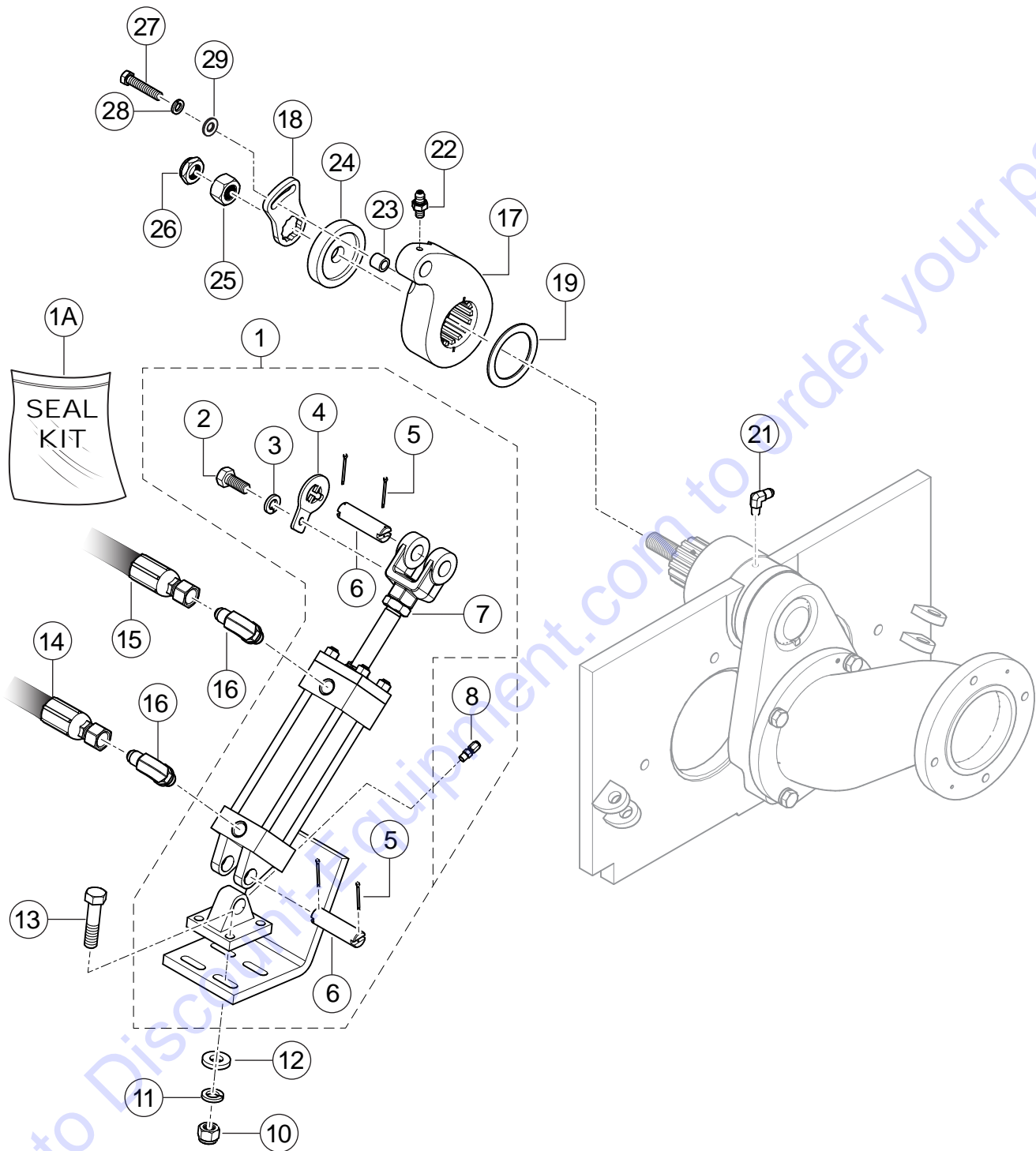



## SHUTTLE CYLINDER ASSEMBLY

<u>NO.</u>	<u>PART NO.</u>	<u>PART NAME</u>	<u>QTY.</u>	<u>REMARKS</u>
1	EM98205	CYLINDER SHUTTLE ASSY. ....	1.....	INCLUDES ITEMS W/\$
1A	EM98106SK	SEAL KIT, SHUTTLE CYLINDER	1	
2\$	492363	BOLT 5/16" DIA. NC X 3/4" GRD. 5	1	
3\$	EM923343	WASHER, LOCK 5/16" .....	1.....	REPLACES P/N 492623
4\$	802009	LOCK	1	
5\$	EM924008	PIN, COTTER 1/8" X 1-1/2" .....	2.....	REPLACES P/N 491688
6\$	521139	WRIST PIN	2	
7\$	515249	NUT, JAM 1"-14	1	
8\$	EM510684	GREASE FITTING .....	1.....	REPLACES P/N 510684
10	492584	NUT, LOCK 1/2" DIA. NC	4	
11	6109180	WASHER, LOCK 1/2" DIA. ....	4.....	REPLACES P/N 492626
12	EM621	WASHER 1/2" SPECIAL .....	4.....	REPLACES P/N 621
13	492397	SCREW HEX 1/2" NC X 2-1/2" GRD. 5	4	
14	803698	HOSE, HYDRAULIC 2.05 FT. (625 MM) .....	2.....	1 PC = 1 FT
15	803699	HOSE, HYDRAULIC 1.53 FT. (465 MM) .....	2.....	1 PC = 1 FT
16	3322	FITTING, 90°	2	
17	EM25236	SHUTTLE CRANK, SPLINED SHAFT	1	
18	518555	CRANK ARM NUT LOCK	1	
19	EM16169	THRUST WASHER	1	
21	EM50449	FITTING, 90° ELBOW	1	
22	EM510684	GREASE FITTING .....	1.....	REPLACES P/N 510684
23	518556	BUSHING, CRANK ARM	1	
24	EM16814	SHUTTLE TENSIONER	1	
25	EM509221	NUT, 1"-14 UNF, GRD 5	1	
26	EM417	NUT, FLEX LOCK 1"-14 NF GRD. 5	1	
27	EM963692	BOLT 1/2" UNC X 1-1/2" .....	1.....	REPLACES P/N 492394
28	492266	WASHER, LOCK 1/2"	1	
29	6109170	WASHER, FLAT 1/2" .....	1.....	REPLACES P/N 504322

# LUBRICATION PISTONS ASSEMBLY

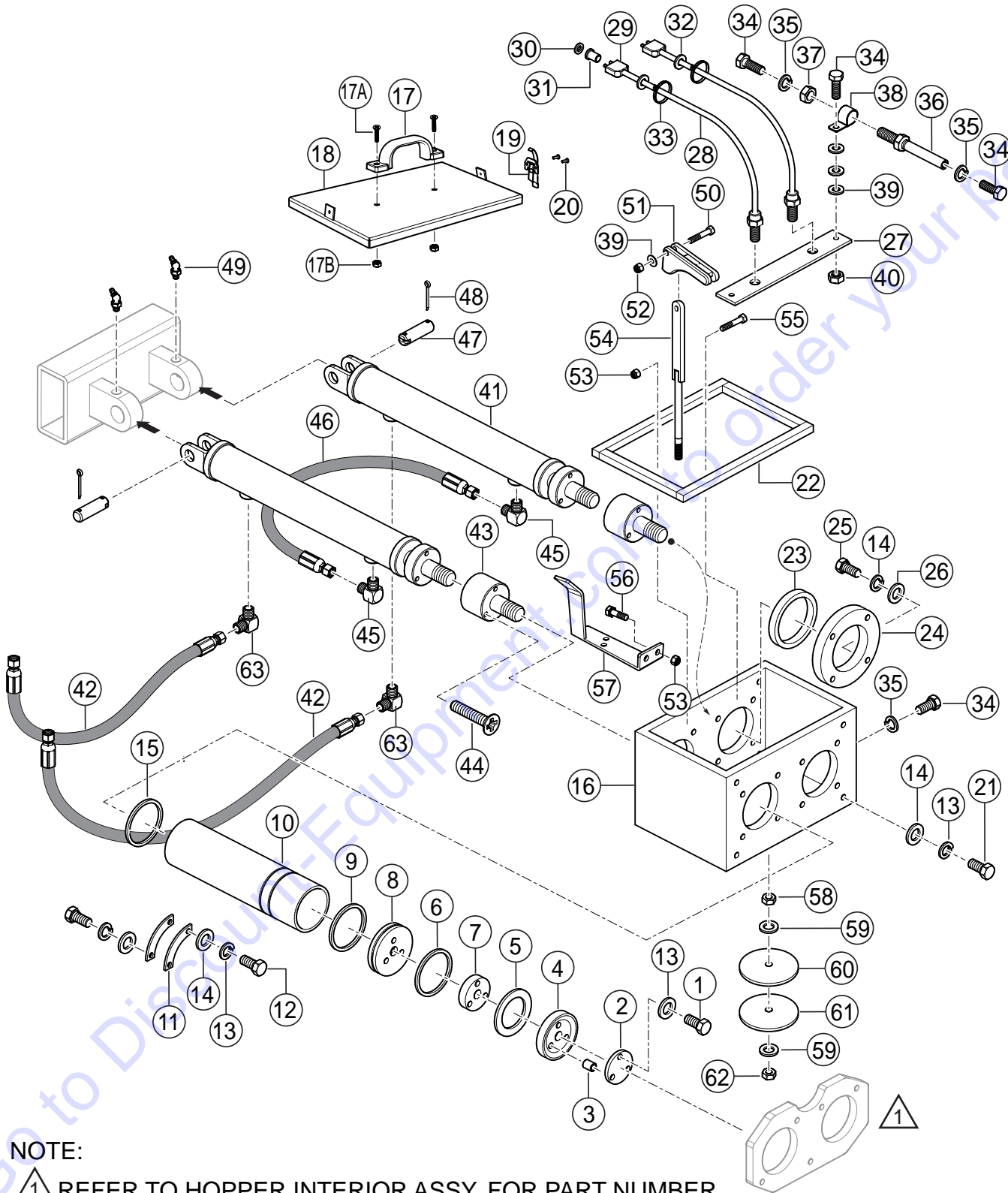

## LUBRICATION PISTONS ASSEMBLY

<u>NO.</u>	<u>PART NO.</u>	<u>PART NAME</u>	<u>QTY.</u>	<u>REMARKS</u>
1	510265	BOLT, HX HD 3/8" NC X 3-1/2" GRD. 8	6	
2	EM16454	FACE PLATE	2	
3	EM16465	PISTON CUP SPACER	6	
4	EM98050	CUP, PISTON-ORANGE	2	
5	EM14408	RING, BRONZE	2	
6	EM16493	RING, FELT	2	
7	EM16462	FELT HOLDER	2	
8	EM98033	OILER PLATE W/HOLES	2	
9	EM14407	O-RING, OILER PLATE	2	
10	EM80801	CYLINDER, CONCRETE	2	
11	EM25110	RETAINER, CYLINDER	4	
12	EM963610	CAP SCREW, 3/8" NC X 1-1/4" GRD. 8	8	
13	0166 A	WASHER, LOCK 3/8"	20	
14	3019092	WASHER, FLAT 3/8"	22	
15	EM16174	O-RING	2	
16	802761	LUBRICATION BOX	1	
17	802751	HANDLE, PLASTIC	1	
17A	513312	BOLT, 1/4" X 1"	2	
17B	492581	NUT, 1/4"-20 NYLON LOCK	2	
18	802997	COVER, LUBRICATION BOX	1	
19	EM514610	LATCH, COVER	1	
20	491754	RIVET	4	
21	492378	BOLT, 3/8" NC X 1-3/4"	6	
22	800033	SEAL, SQUARE	1	
23	EM274351	SEAL, LUBE BOX	2	
24	EM50425	FLANGE, RING	2	
25	492451	BOLT, 3/8"-24 X 1"	8	
26	EM50443	SEAL, OIL BOX	8	
27	EM514208	BAR, PROXIMITY SWITCH SUPPORT	2	
28	EM98163	SWITCH, PROXIMITY W/CABLE	2	
29	EM98135	HOUSING, FEMALE	2	
30	EM98134	SEAL, CONNECTOR HOUSING	6	
31	EM98138	TERMINAL PIN, FEMALE	6	
32	514611	GROMMET	2	
33	EM504505	TIE WRAP	8	
34	492303	SCREW, 5/16"-18 X 1-1/4"	6	
35	EM923343	WASHER, LOCK 5/16"	6	
36	EM514216	ADJUSTMENT ROD, PROX. SWITCH	2	
37	6109160	NUT, HEX 1/2"	4	
38	EM514207	BRACKET, ADJUSTMENT ROD	2	
39	923023	WASHER, FLAT 5/16"	7	
40	2105164	NUT, 5/16"	2	

# LUBRICATION PISTONS ASSEMBLY (CONT'D.)

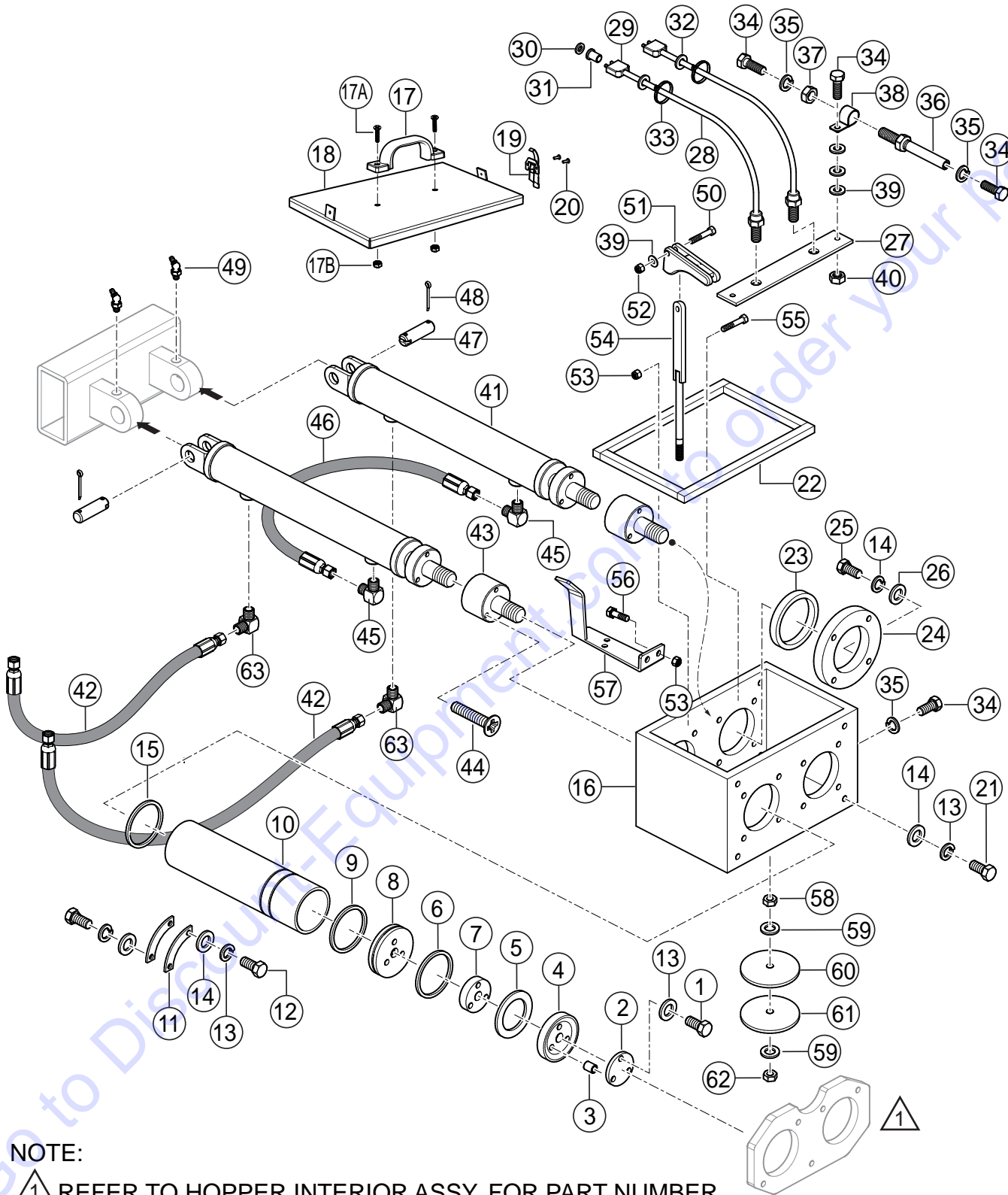

## LUBRICATION PISTONS ASSEMBLY (CONT'D.)

<u>NO.</u>	<u>PART NO.</u>	<u>PART NAME</u>	<u>QTY.</u>	<u>REMARKS</u>
41	EM804423A	CYLINDER, HYDRAULIC MAIN	2	
42	EM514920	HOSE, HYD. MAIN CYL. 1.45 FT. (445 MM).....	2	1 PC = 1 FT.
43	EM514202	EXTENSION SPACER	2	
44	EM185	BOLT, SOCKET HEAD 3/8"-16 X 3"	6	
45	EM25497	FITTING, 90°	2	
46	514067	HOSE, HYDRAULIC SLAVE	1	
47	EM16459	PIN, WRIST	2	
48	EM505723	PIN, COTTER	4	
49	EM491701	FITTING, GREASE	2	
50	492379	SCREW, CAP 3/8"	1	
51	802678	LEVER, RELEASE	1	
52	EM969013	NUT, NYLOC 3/8" NC	1	
53	2105164	NUT, NYLOC 5/16"-18	1	
54	802677	PLUNGER, ROD	1	
55	2105162	BOLT, 5/16" NC X 1-3/4" GRD. 5	2	
56	0202	SCREW, HHC 5/16"-18 X 1" ZN	2	
57	802850	BRACKET, HOSE	1	
58	802955	NUT	1	
59	492599	WASHER, 1/2"	2	
60	802682	RUBBER SEAL	1	
61	802681	SEAL PLATE	1	
62	492584	NUT, LOCK 1/2"	1	
63	EM516411	FITTING, 90°	2	

# FUEL TANK ASSEMBLY

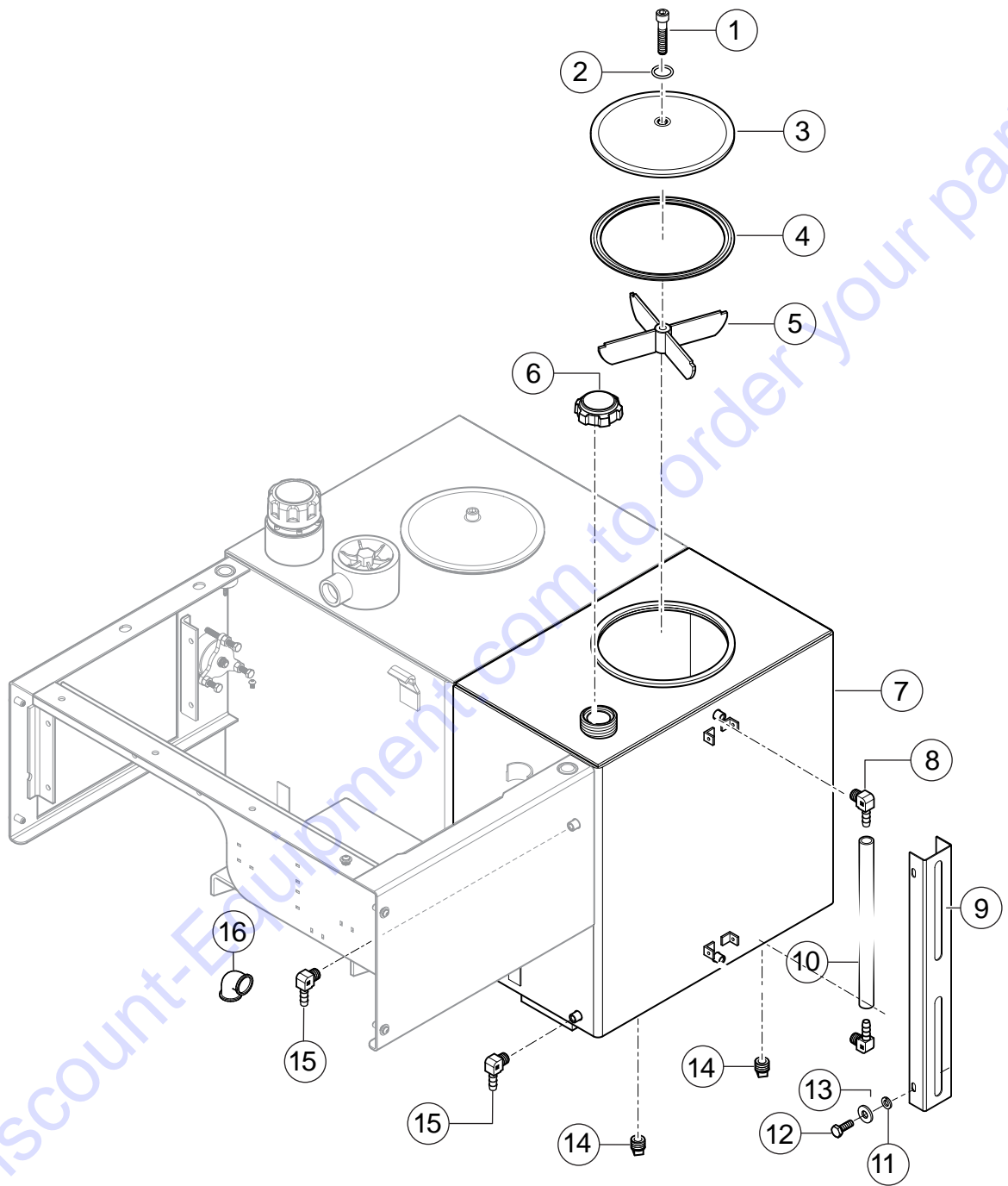

# PARTS FINDER

**Search Website  
by Part Number**



**Search Manual  
Library For Parts  
Manual & Lookup Part  
Numbers – Purchase  
or Request Quote**

**Search Manuals**

Enter your information to help us find the right parts manual for your machine.

\* Brand:

\* Model:

\* Serial:

\* Part Number:

SEARCH

**Can't Find Part or  
Manual? Request Help  
by Manufacturer,  
Model & Description**

**Parts Order Form**

Please fill in the following information to help us find the right part for your machine.

Manufacturer:	<input type="text"/>
Model:	<input type="text"/>
Description:	<input type="text"/>
Part Number:	<input type="text"/>
Quantity:	<input type="text"/>
Notes:	<input type="text"/>

Discount-Equipment.com is your online resource for quality parts & equipment.

Florida: **561-964-4949** Outside Florida TOLL FREE: **877-690-3101**

## Need parts?

Click on this link: <http://www.discount-equipment.com/category/5443-parts/> and choose one of the options to help get the right parts and equipment you are looking for. Please have the machine model and serial number available in order to help us get you the correct parts. If you don't find the part on the website or on one of the online manuals, please fill out the request form and one of our experienced staff members will get back to you with a quote for the right part that your machine needs.

We sell worldwide for the brands: Genie, Terex, JLG, MultiQuip, Mikasa, Essick, Whiteman, Mayco, Toro Stone, Diamond Products, Generac Magnum, Airman, Haulotte, Barreto, Power Blanket, Nifty Lift, Atlas Copco, Chicago Pneumatic, Allmand, Miller Curber, Skyjack, Lull, Skytrak, Tsurumi, Husquvarna Target, Stow, Wacker, Sakai, Mi-T-M, Sullair, Basic, Dynapac, MBW, Weber, Bartell, Bennar Newman, Haulotte, Ditch Runner, Menegotti, Morrison, Contec, Buddy, Crown, Edco, Wyco, Bomag, Laymor, EZ Trench, Bil-Jax, F.S. Curtis, Gehl Pavers, Heli, Honda, ICS/PowerGrit, IHI, Partner, Imer, Clipper, MMD, Koshin, Rice, CH&E, General Equipment, Amida, Coleman, NAC, Gradall, Square Shooter, Kent, Stanley, Tamco, Toku, Hatz, Kohler, Robin, Wisconsin, Northrock, Oztec, Toker TK, Rol-Air, APT, Wylie, Ingersoll Rand / Doosan, Innovatech, Con X, Ammann, Mecalac, Makinex, Smith Surface Prep, Small Line, Wanco, Yanmar

## FUEL TANK ASSEMBLY

<u>NO.</u>	<u>PART NO.</u>	<u>PART NAME</u>	<u>QTY.</u>	<u>REMARKS</u>
1	505990	BOLT, 5/16" X 2-1/2"	1	
2	520343	O-RING	3	
3	EM800299	COVER	1	
4	EM801789	O-RING	1	
5	EM800301	RETAINER	1	
6	2108	CAP, FUEL TANK	1	
7	803675	TANK, HYDRAULIC/FUEL	1	
8	EM20426	ELBOW, BRASS 90° 1/4" X 1/4"	2	
9	516878	GUARD BRACKET FUEL TUBE	1	
10	518067	TUBE, FUEL	1	
11	2101402	WASHER LOCK 1/4" DIA. ....	4	REPLACES P/N 492622
12	DULT100443	BOLT M6 X 20 GRD. 2	4	
13	DULT100531	WASHER, FLAT M6	4	
14	506094	PLUG 1/2" NPT GALVANIZED	2	
15	513955	FITTING, 90° 1/4"	2	
16	EM491664	ELBOW, 3/4" .....	2	REPLACES P/N 491664

Go to Discount-Equipment.com to order your parts



# HEAT EXCHANGER ASSEMBLY

HYDRAULIC TANK  
RETURN FILTER

MANIFOLD

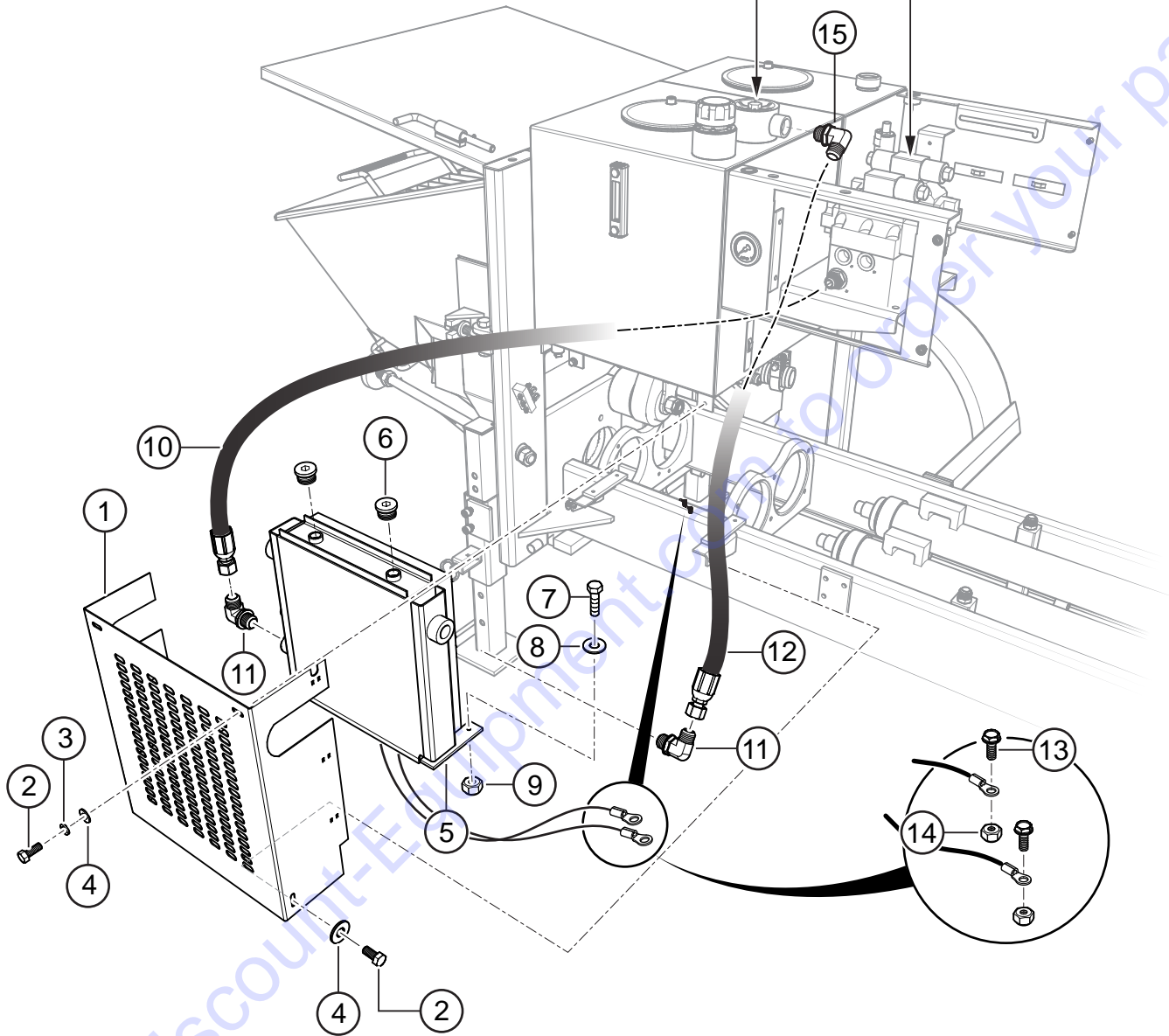

## HEAT EXCHANGER ASSEMBLY

<u>NO.</u>	<u>PART NO.</u>	<u>PART NAME</u>	<u>QTY.</u>	<u>REMARKS</u>
1	516812	HEAT EXCHANGER COVER	1	
2	492363	BOLT, 5/16" DIA. NC X 3/4" GRD. 5	6	
3	0166 A	WASHER, LOCK 3/8"	4	
4	100531	WASHER, FLAT M6	31	
5	EM98118	HEAT EXCHANGER ASSEMBLY	1	
6	18147	ADAPTER	2	
7	0202	SCREW, HHC 5/16" X 18 X 1 .....	10.....	REPLACES P/N 492364
8	EM923023	WASHER, FLAT 5/16" .....	12.....	REPLACES P/N 492597
9	2105164	NUT, NYLON 5/16"-18 .....	6.....	REPLACES P/N 492582
10	518000	HOSE, HYDRAULIC 3.9 FT. (1180 MM) .....	1.....	1 PC = 1 FT
11	EM25497	FITTING	4	
12	518001	HOSE, HYDRAULIC 2.0 FT. (610 MM) .....	1.....	1 PC = 1 FT
13	512367J	BOLT, 3/16 NC X 1/2 GRD. 2	2	
14	5031195J	NUT, 3/16" NC NYLOC	2	
15	EM18436	ELBOW, 90° MALE	1	

Go to Discount-Equipment.com to order your parts

# PISTON ACCUMULATOR ASSEMBLY

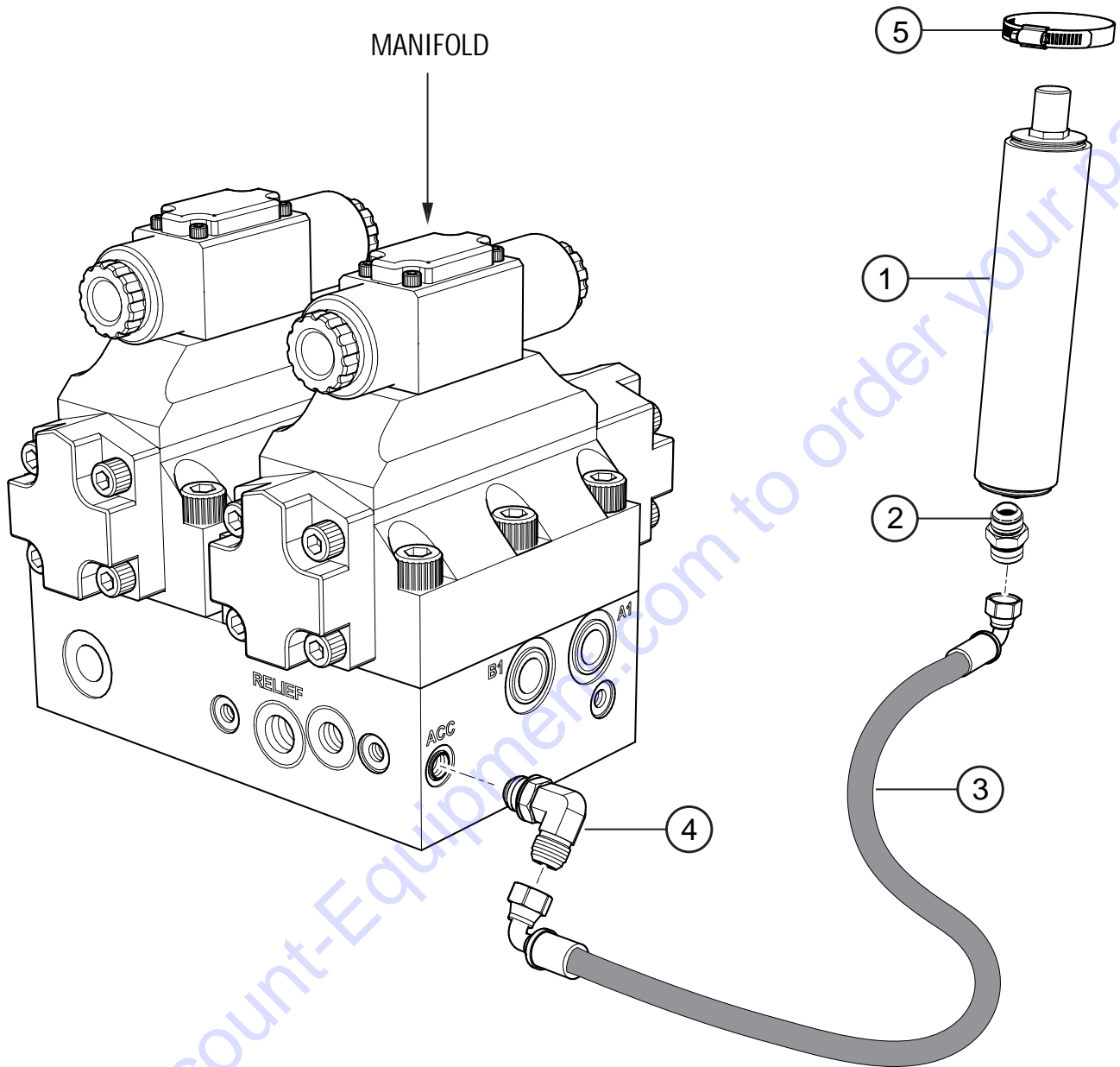

## PISTON ACCUMULATOR ASSEMBLY

---

<u>NO.</u>	<u>PART NO.</u>	<u>PART NAME</u>	<u>QTY.</u>	<u>REMARKS</u>
1	EM98265	ACCUMULATOR, PISTON	1	
2	518192	STRAIGHT MALE CONNECTOR	1	
3	518009	HOSE, HYDRAULIC 2.3 FT. (692 MM) .....	3.....	1 PC = 1 FT
4	511803	ADAPTER, ELBOW	1	
5	513126	CLAMP	1	

Go to Discount-Equipment.com to order your parts

# LUBRICATION PANEL ASSEMBLY

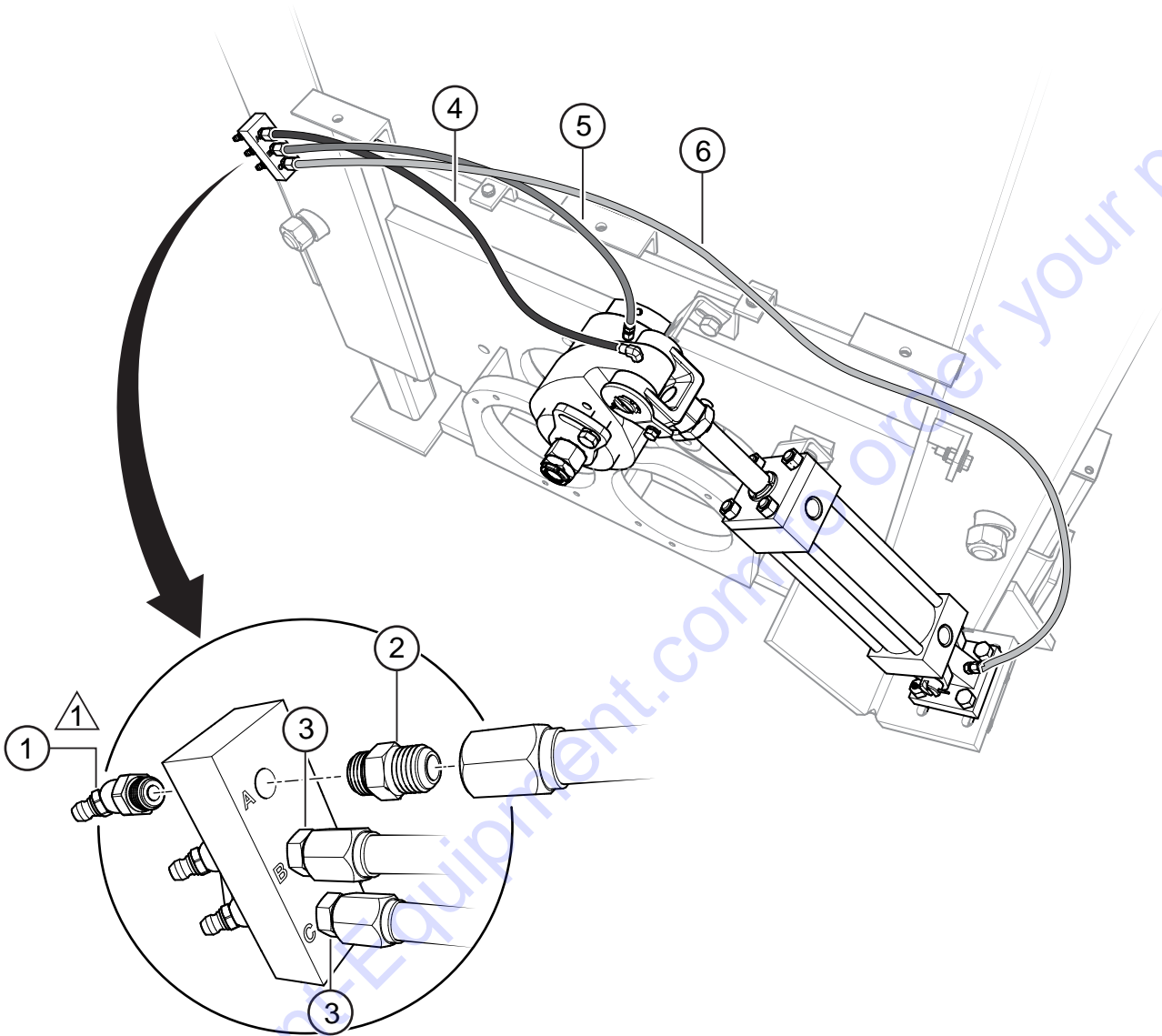

POSITION	LOCATION	LENGTH OF LINES
A .....	CLEVIS GREASE POINT .....	34 in. (1.1 m)
B .....	SWING AXLE BUSHING GREASE POINT .....	26 in. (.85 m)
C .....	PIVOT BRACKET GREASE POINT .....	41 in. (1.5 m)

## NOTE:

-  GREASE DAILY, TWO OR THREE SHOTS OF #2 MULTIPURPOSE AUTOMOTIVE GREASE. OVERGREASING ANY BEARING WILL NOT DAMAGE THE MACHINE. ALWAYS GREASE **BEFORE AND AFTER OPERATION.**

## LUBRICATION PANEL ASSEMBLY

<u>NO.</u>	<u>PART NO.</u>	<u>PART NAME</u>	<u>QTY.</u>	<u>REMARKS</u>
1	EM491701	FITTING ZERK, GREASE	3	
2	515328	ADAPTOR, FITTING	1	
3	EM510684	FITTING .....	2.....	REPLACES P/N 510684
4	802639	HOSE, RUBBER	1	
5		STEEL LINE.....	AR.....	OBTAIN LOCALLY
6	EM505516	HOSE, PLASTIC 1/4" .....	AR.....	1 PC = 1 FT

Go to Discount-Equipment.com to order your parts

# ENGINE COVER ASSEMBLY

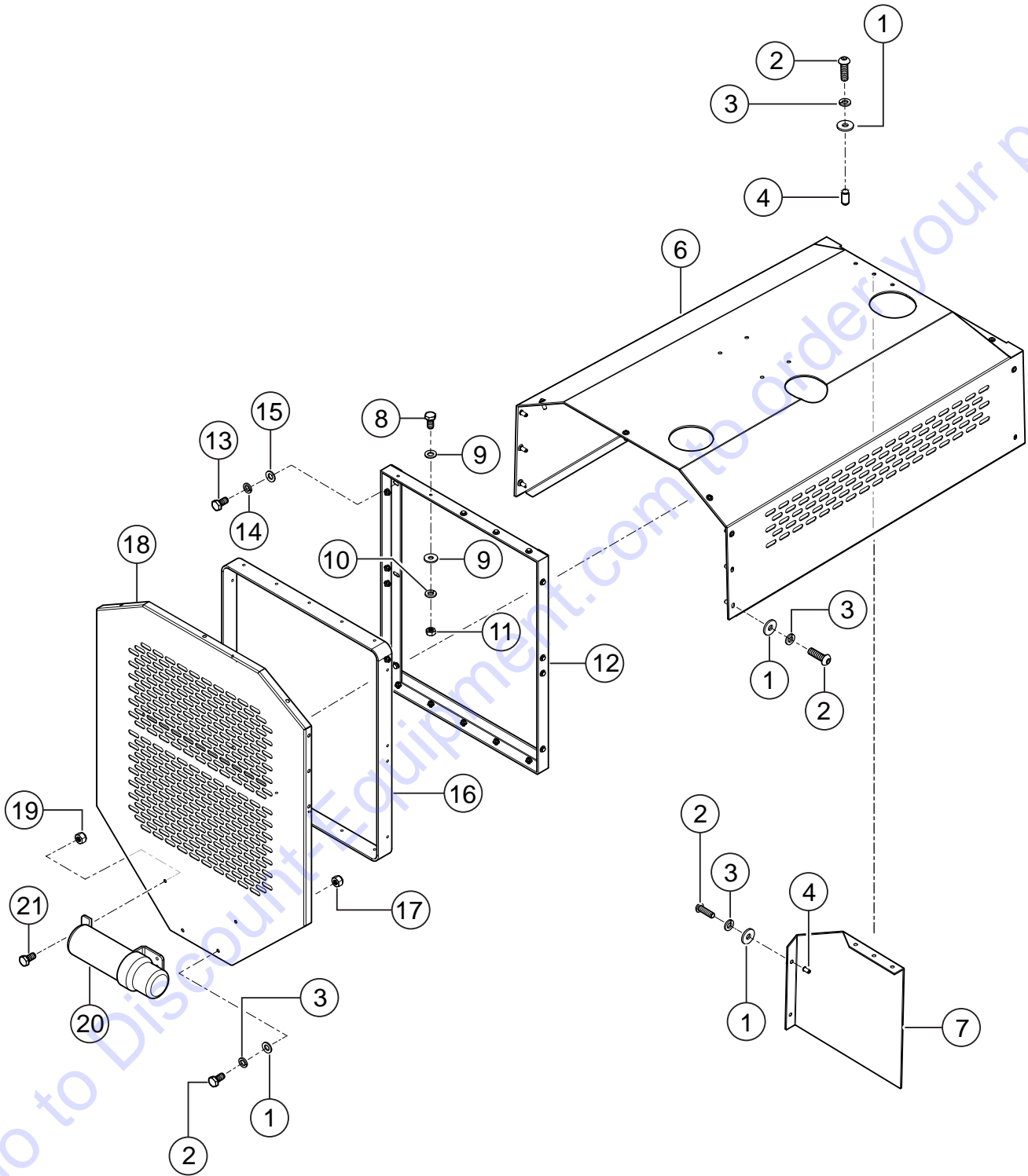

## ENGINE COVER ASSEMBLY

<u>NO.</u>	<u>PART NO.</u>	<u>PART NAME</u>	<u>QTY.</u>	<u>REMARKS</u>
1	100531	WASHER, FLAT, 1/4"	31	
2	100443	BOLT, M6 X 20	31	
3	2101402	WASHER, LOCK 1/4" DIA. ....	27	REPLACES P/N 492622
4	100602	RIVET, NUT M6	30	
6	EM803676	TOP COVER, ENGINE	1	
7	803606	HEAT DEFLECTOR	1	
8	492356	BOLT, 1/4" X 3/4"	18	
9	100531	WASHER, FLAT, 1/4"	38	
10	2101402	WASHER, LOCK 1/4" DIA. ....	18	REPLACES P/N 492622
11	2101428	NUT HEX 1/4"-20.....	18	REPLACES P/N 492561
12	803492	EXHAUST VENT	1	
13	100265	BOLT, M8 X 16 GRD. 8.8	6	
14	030208200	LOCK, WASHER M8.....	6	REPLACES P/N 506597
15	100494	WASHER, FLAT M8	6	
16	803489	RUBBER DUCT VENTILATION	1	
17	492581	NUT, 1/4"-20 NYLON LOCKNUT	4	
18	EM803486	FRONT PANEL, ENGINE	1	
19	2105164	NUT, NYLON 5/16"-18.....	3	REPLACES P/N 492582
20	23297	MANUAL HOLDER	1	
21	0202	SCREW, HHC 5/16"-18 X 1" ZN	3	



# HYDRAULIC TANK ASSEMBLY

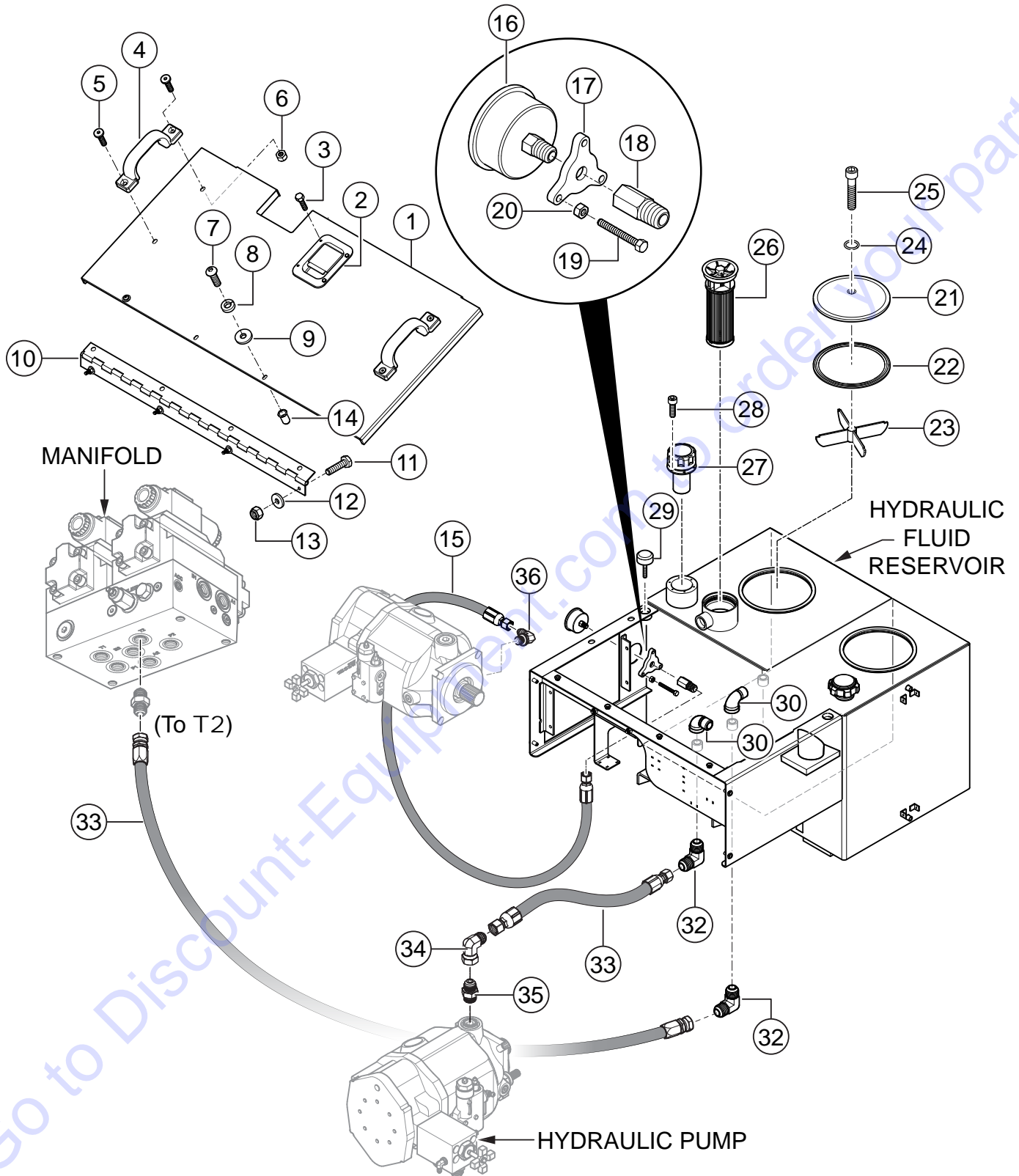

## HYDRAULIC TANK ASSEMBLY

<u>NO.</u>	<u>PART NO.</u>	<u>PART NAME</u>	<u>QTY.</u>	<u>REMARKS</u>
1	803481	COVER, HYDRAULIC TANK	1	
2	802579	LOCKING LATCH	1	
3	EM503115	SCREW.....	4.....	REPLACES P/N 503115
4	802751	HANDLE, COVER	2	
5	513312	BOLT 1/4" X 1"	4	
6	492581	NUT, NYLOC 1/4"-20	4	
7	DULT100443	SCREW	21	
8	2101402	WASHER, LOCK 1/4" DIA. ....	4.....	REPLACES P/N 492622
9	DULT100531	WASHER, FLAT	4	
10	521262	HINGE	1	
11	492357	BOLT GRD. 8	18	
12	DULT100531	WASHER, FLAT	18	
13	492581	NUT, NYLOC 1/4"-20	38	
14	DULT100602	BLIND NUT	30	
15	803698	HOSE, HYDRAULIC 2.7 FT. (820 MM) .....	3.....	1 PC = 1 FT
16	EM97067	GAUGE, 5000 PSI, MAIN	1	
17	804077	BRACKET, GAUGE	1	
18	EM25523	ADAPTER, PRESSURE GAUGE	1	
19	518702	SCREW	3	
20	2105164	NUT HEX 5/16" DIA. NC.....	3.....	REPLACES P/N 492553
21	EM800299	COVER	1	
22	EM801789	O-RING	1	
23	EM800301	RETAINER	1	
24	520343	O-RING	3	
25	505990	BOLT 1/2" X 2-1/2"	1	
26	EM98245	FILTER, HYDRAULIC	1	
27	EM98263	CAP FILLER	1	
28	492267	BOLT, ALLEN 10 X 32 X 26"	6	
29	513955	RUBBER BUMPER STEM	2	
30	491164	NIPPLE, 90° 1/4"	2	
32	509784	FITTING, 90°	2	
33	518010	HOSE, HYDRAULIC 2.5 FT. (770 MM) .....	3.....	1 PC = 1 FT
34	509353	FITTING, 90°	1	
35	491372	FITTING, STRAIGHT	6	
36	EM25429	FITTING, 90°	1	

# ENGINE MOUNTING EXHAUST ASSEMBLY

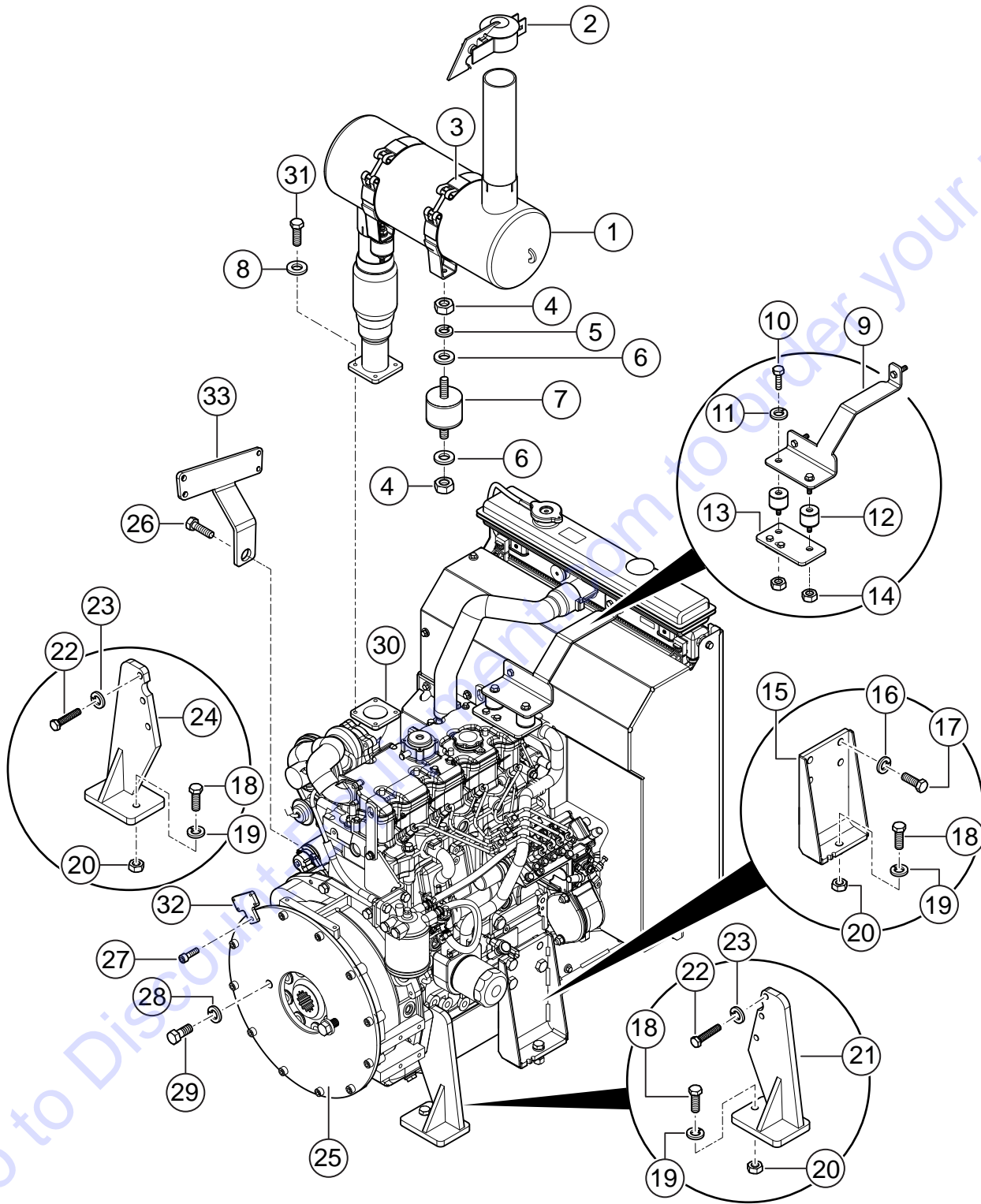

## ENGINE MOUNTING EXHAUST ASSEMBLY

<u>NO.</u>	<u>PART NO.</u>	<u>PART NAME</u>	<u>QTY.</u>	<u>REMARKS</u>
1	803665	MUFFLER	1	
2	510897	CAP, EXHAUST PIPE	1	
3	802465	CLAMP, EXHAUST MUFFLER	2	
4	504482	NUT, HEX M10 GRD. 8	8	
5	0166 A	WASHER, LOCK 3/8" DIA. ....	4	REPLACES P/N 492624
6	3019092	WASHER, FLAT 3/8" .....	8	REPLACES P/N 506488
7	801637	CUSHION, RUBBER	4	
8	TK872229	WASHER, FLAT 3/8"	2	WHERE ON DWG???
9	803618	RADIATOR SUPPORT	1	
10	492363	BOLT, 5/16" DIA. NC X 3/4" GRD. 5	2	
11	EM923057	WASHER, FLAT 1/4" .....	2	REPLACES P/N 492596
12	EM505201	SHOCK MOUNT	2	
13	803619	SUPPORT PLATE	1	
14	2105164	NUT, NYLON 5/16"-18 .....	2	REPLACES P/N 492582
15	TBD	ENGINE MOUNT, RIGHT	1	
16	TBD	WASHER, FLAT	4	
17	TBD	BOLT	4	
18	EM963692	BOLT, 1/2" UNC X 1-1/2" .....	4	REPLACES P/N 492394
19	6109180	WASHER, LOCK 1/2" DIA. ....	4	REPLACES P/N 492626
20	6109160	NUT, HEX 1/2" DIA. NC .....	4	REPLACES P/N 492556
21	803629	RIGHT, MOTOR SUPPORT	1	
22	DULT100284	BOLT, M10 X 55 GRD. 8.8	6	
23	506622	WASHER, M10 PRESSURE SS	6	
24	803630	LEFT, MOTOR SUPPORT	1	
25	521427	MOTOR-PUMP COUPLING	1	
26	TBD	BOLT	1	
27	492264	BOLT, 3/8" X 1"	12	
28	EM620	WASHER, FLAT 5/8" .....	4	REPLACES P/N 505882
29	492406	BOLT, 5/8"NC X 1-1/2", GRD. 8	4	
30	EM98281	ENGINE, PERKINS FLEX 404D-22TA	1	
31	TBD	SCREW, HHCS	4	
32	803666	SUPPORT HARNESS	2	
33	803741	HARNESS CLIP	1	

# AIR FILTER ASSEMBLY

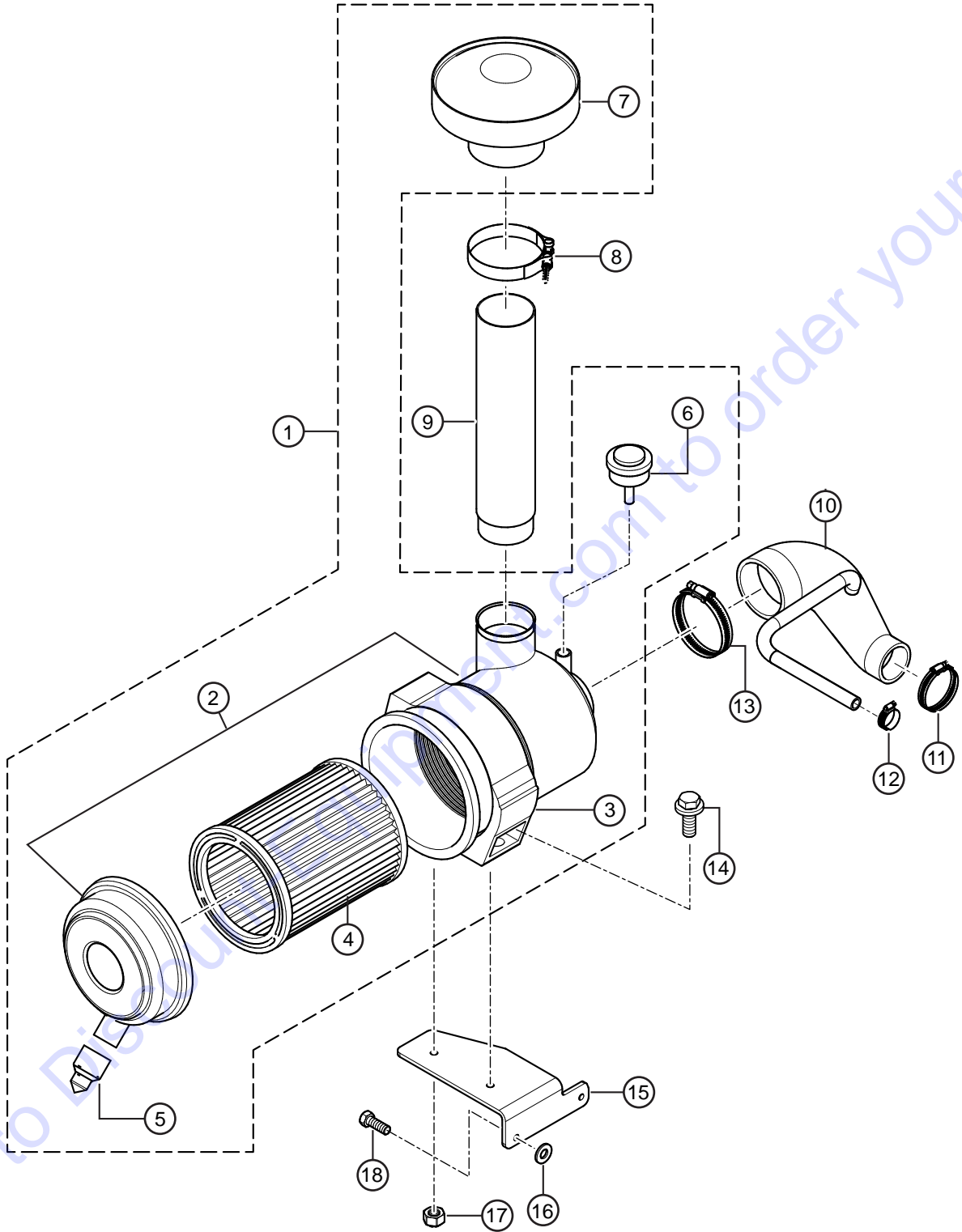

## AIR FILTER ASSEMBLY

<u>NO.</u>	<u>PART NO.</u>	<u>PART NAME</u>	<u>QTY.</u>	<u>REMARKS</u>
1	135016350	AIR FILTER ASSEMBLY .....	1.....	INCLUDES ITEMS W/%
2%		BODY .....	1.....	NOT SOLD SEPARATELY
3%	26510418	BRACKET	1	
4%	135326206	AIR FILTER ELEMENT, MAIN	1	
5%	26510194	DUST VALVE	1	
6%	26510402	DUST INDICATOR	1	
7%	803914	COVER	1	
8	803728	CLAMP 3.25" DIA.	2	
9	803617	TUBE, AIR FILTER	1	
10	U35597941	HOSE, AIR FILTER	1	
11	21825194	CLAMP	1	
12	2481882	CLAMP	1	
13	0180072	CLAMP	1	
14	2314H005	SCREW	2	
15	U30976791	SUPPORT BRACKET	1	
16	199216340	SPACER	2	
17	023100008	NUT	2	
18	2314H003	SCREW	2	

Go to Discount-Equipment.com to order your parts

# THROTTLE ASSEMBLY

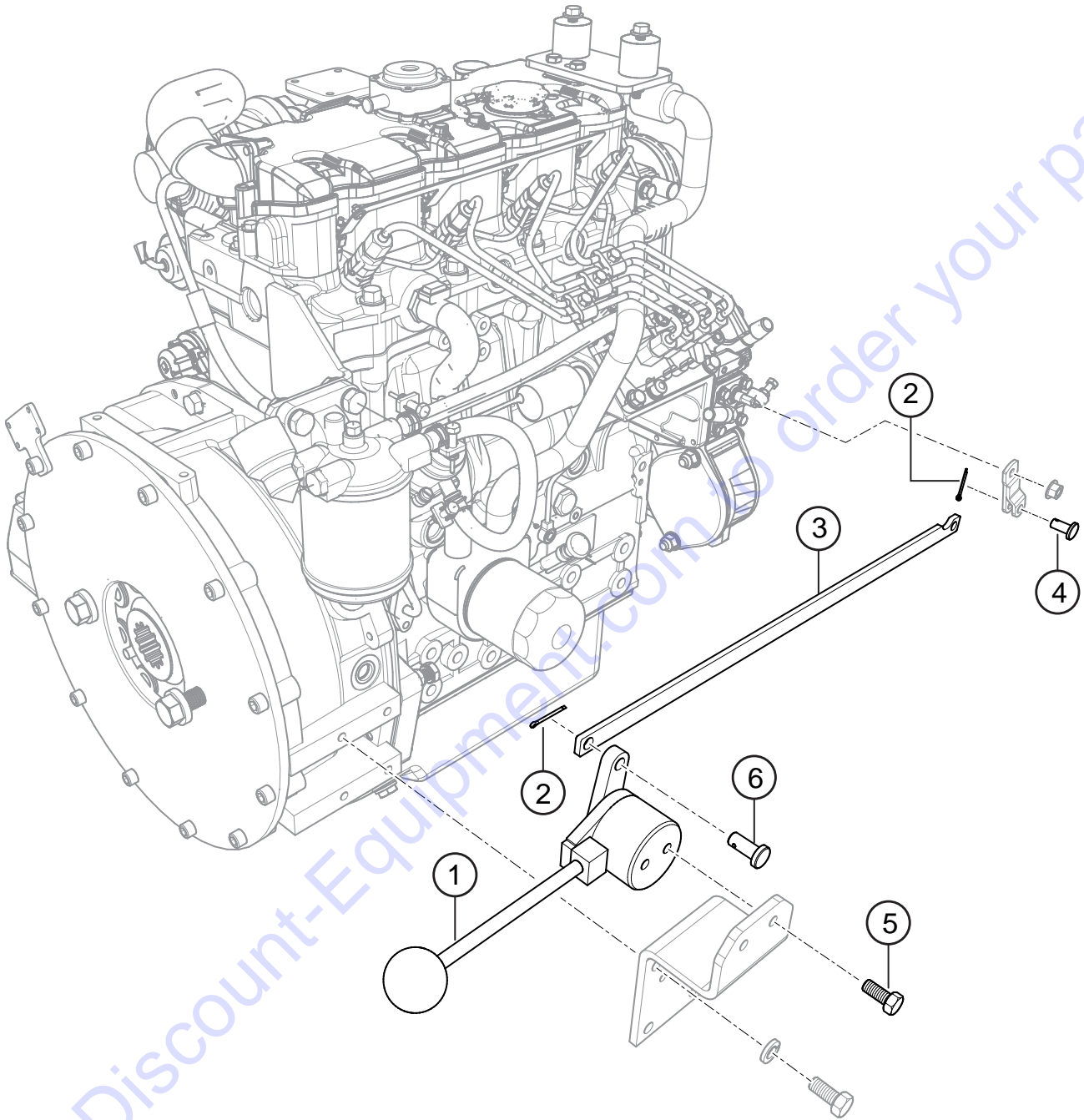

## THROTTLE ASSEMBLY

---

<u>NO.</u>	<u>PART NO.</u>	<u>PART NAME</u>	<u>QTY.</u>	<u>REMARKS</u>
1	517548	HANDLE, CONTROL ACCELERATION	1	
2	509074	PIN, COTTER 3/32"	2	
3	803669	ROD, THROTTLE	1	
4	801680	BOLT, ACTION	1	
5	492449	BOLT, 5/16" NF X 3/4" GRD. 5	2	
6	801679	BOLT, HANDLE CONTROL	1	

Go to Discount-Equipment.com to order your parts



# FUEL FILTERS/WATER SEPARATOR ASSEMBLY

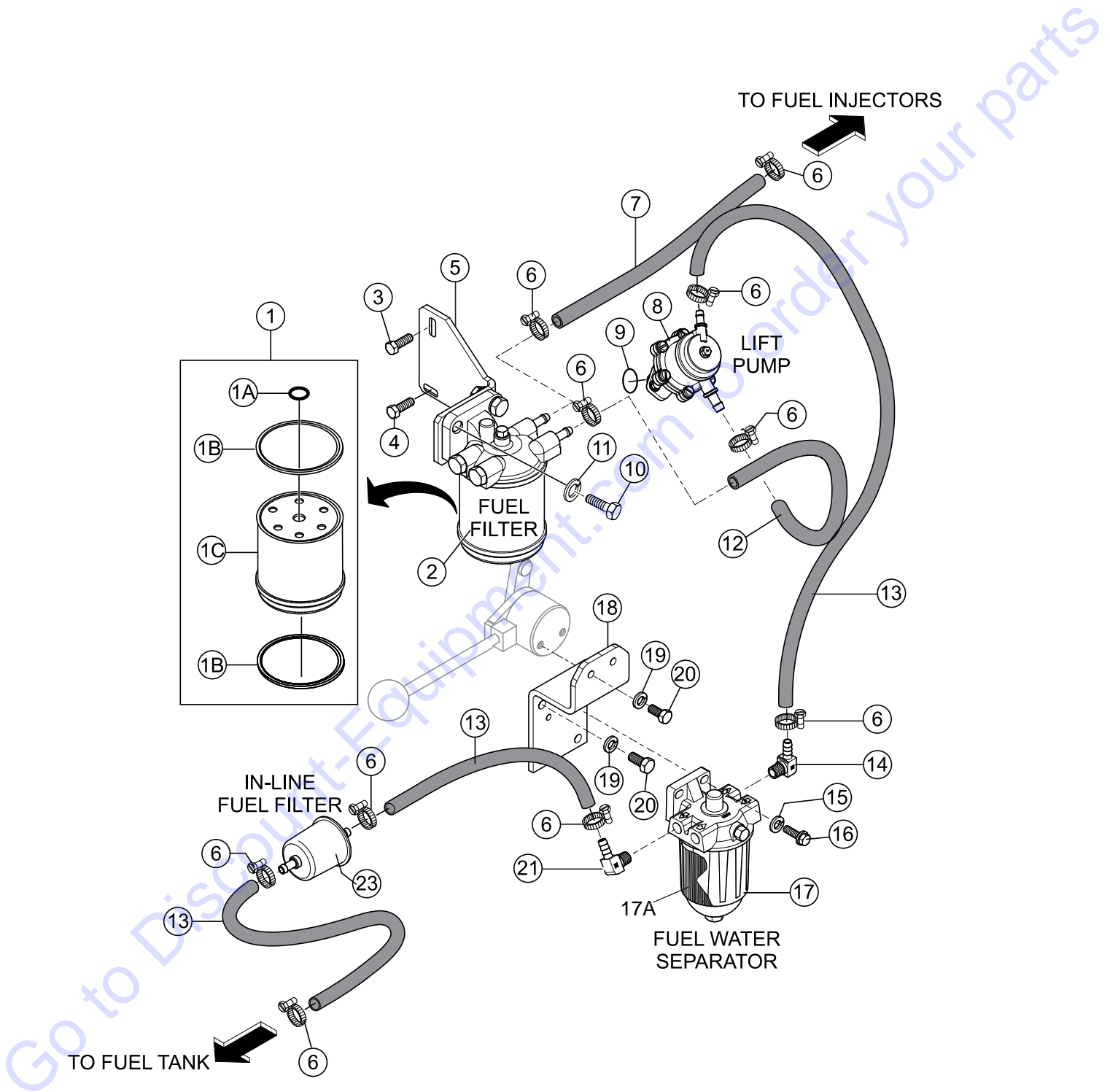

## FUEL FILTERS/WATER SEPARATOR ASSEMBLY

<u>NO.</u>	<u>PART NO.</u>	<u>PART NAME</u>	<u>QTY.</u>	<u>REMARKS</u>
1	2651117	FUEL FILTER KIT .....	1.....	INCLUDES ITEMS W/%
1A%	2650014	SEAL/O-RING	1	
1B%	0490786	SEAL	2	
1C%		ELEMENT .....	1.....	NOT SOLD SEPARATELY
2	2656613	FUEL FILTER ASSEMBLY	1	
3	011510820	SCREW	1	
4	2314H003	SCREW	1	
5	TPN508	SUPPORT BRACKET	1	
6	802574	CLAMP, WORM	10	
7	T682209628	HOSE, FUEL LIFT PUMP	1	
8	130506350	LIFT PUMP	1	
9	2415A070	SEAL/O-RING	1	
10	2314J004	SCREW	2	
11	027110010	WASHER, LOCK	2	
12	T68209189	HOSE, FUEL LIFT PUMP	1	
13	514536	HOSE, 5/16"	AR	
14	514561	FITTING, 90°	1	
15	492623	WASHER, LOCK 5/16"	2	
16	011208025	BOLT 8 X 25.....	2.....	REPLACES P/N 508342
17	34505	FUEL WATER SEPARATOR	1	
17A	34505E	ELEMENT, FUEL WATER SEPARATOR	1	
18	803607	BRACKET, FUEL WATER SEPARATOR	1	
19	0166 A	WASHER, LOCK 3/8" DIA.....	4.....	REPLACES P/N 492624
20	EM963055	BOLT 3/8" DIA.....	4.....	REPLACES P/N 492373
21	514561	FITTING, 90°	1	
23	802513	IN-LINE FUEL FILTER	1	



## HYDRAULIC PUMP ASSEMBLY

<u>NO.</u>	<u>PART NO.</u>	<u>PART NAME</u>	<u>QTY.</u>	<u>REMARKS</u>
1	EM801362	PUMP	1	
4	514628	FLANGE, SUCTION PIPE, PUMP SIDE	1	
5	EM963692	CAP SCREW, HHCS 1/2"-13 X 1-1/2" GRD. 5	4	
6	6109180	WASHER, LOCK 1/2"	8	
7	EM25429	FITTING, 90°	2	
8	EM514627	SUCTION PIPE ADAPTER	1	
9	515207	CLAMP, ELBOW	2	
10	EM514623	HOSE, SUCTION 2"	1	
11	EM514718	SUCTION PIPE ADAPTER	1	
12	EM514719	FLANGE, SUCTION PIPE	1	
13	516675	FITTING, STRAIGHT	6	
14	509784	FITTING, 90°	2	
15	3322	FITTING, 90°	2	
16	803698	HOSE, HYDRAULIC 2.0 FT. (625 MM) .....	2	1 PC = 1 FT
17	803699	HOSE, HYDRAULIC 1.5 FT. (465 MM) .....	2	1 PC = 1 FT
20	803696	HOSE, HYDRAULIC 1.5 FT. (455 MM) .....	2	1 PC = 1 FT
21	803697	HOSE, HYDRAULIC 1.55 FT. (475 MM) .....	2	1 PC = 1 FT
22	518004	HOSE, HYDRAULIC 2.0 FT. (620 MM) .....	2	1 PC = 1 FT
28	516875	HOSE, HYDRAULIC 1.6 FT. (500 MM) .....	2	1 PC = 1 FT
30	491372	FITTING, STRAIGHT	2	
31	EM801363	CONTROL VALVE, MANIFOLD	1	
32	511428	SCREW, ALLEN HD. 1/2"-13 X 3	4	
34	803693	HOSE, HYDRAULIC 2.6 FT. (780 MM) .....	3	1 PC = 1 FT
35	803694	HOSE, HYDRAULIC 2.9 FT. (890 MM) .....	3	1 PC = 1 FT
36	25459	FITTING, 90°	1	
37	514488	FITTING, 90°	1	

# MANIFOLD ASSEMBLY

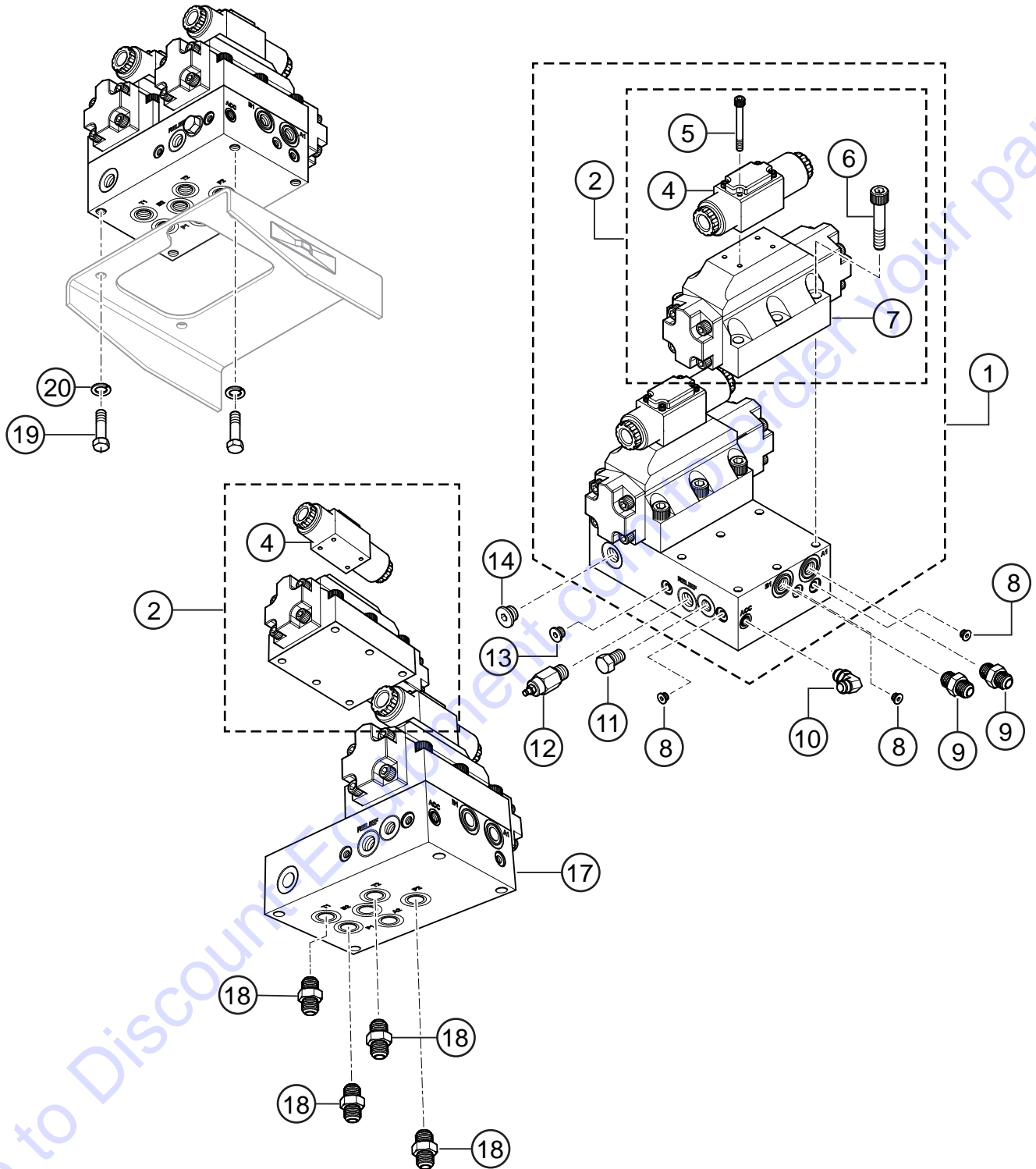

## MANIFOLD ASSEMBLY

<u>NO.</u>	<u>PART NO.</u>	<u>PART NAME</u>	<u>QTY.</u>	<u>REMARKS</u>
1	EM98243A	MANIFOLD ASSEMBLY .....	2.....	INCLUDES ITEMS W/%
2%	EM98221	CYCLING VALVE, SWING W/PILOTS .....	2.....	INCLUDES ITEMS W/\$
4\$%	EM98222	PILOT VALVE, SHUTTLE	2	
5\$%		BOLT, SHCS 1/2" X 1-1/4" .....	8.....	CONTACT DISCOUNT-EQUIPMENT
6\$%		BOLT, SHCS 1/2" X 2-1/4" .....	12.....	CONTACT DISCOUNT-EQUIPMENT
7\$#%		SWING VALVE .....	1.....	CONTACT DISCOUNT-EQUIPMENT
8		PLUG .....	3.....	CONTACT DISCOUNT-EQUIPMENT
9	513548	FITTING, STRAIGHT	2	
10	511803	ADAPTER ELBOW	1	
11		PLUG .....	1.....	CONTACT DISCOUNT-EQUIPMENT
12	EM98226	RELIEF VALVE	1	
13		PLUG .....	3.....	CONTACT DISCOUNT-EQUIPMENT
14		PLUG .....	3.....	CONTACT DISCOUNT-EQUIPMENT
17		BODY .....	1.....	CONTACT DISCOUNT-EQUIPMENT
18	491372	STRAIGHT FITTING	4	
19	EM963102	BOLT, 1/2" X 1-1/4"	4	
20	6109180	WASHER, LOCK 1/2"	4	

Go to Discount-Equipment.com to order your parts

# CONTROL BOX ASSEMBLY

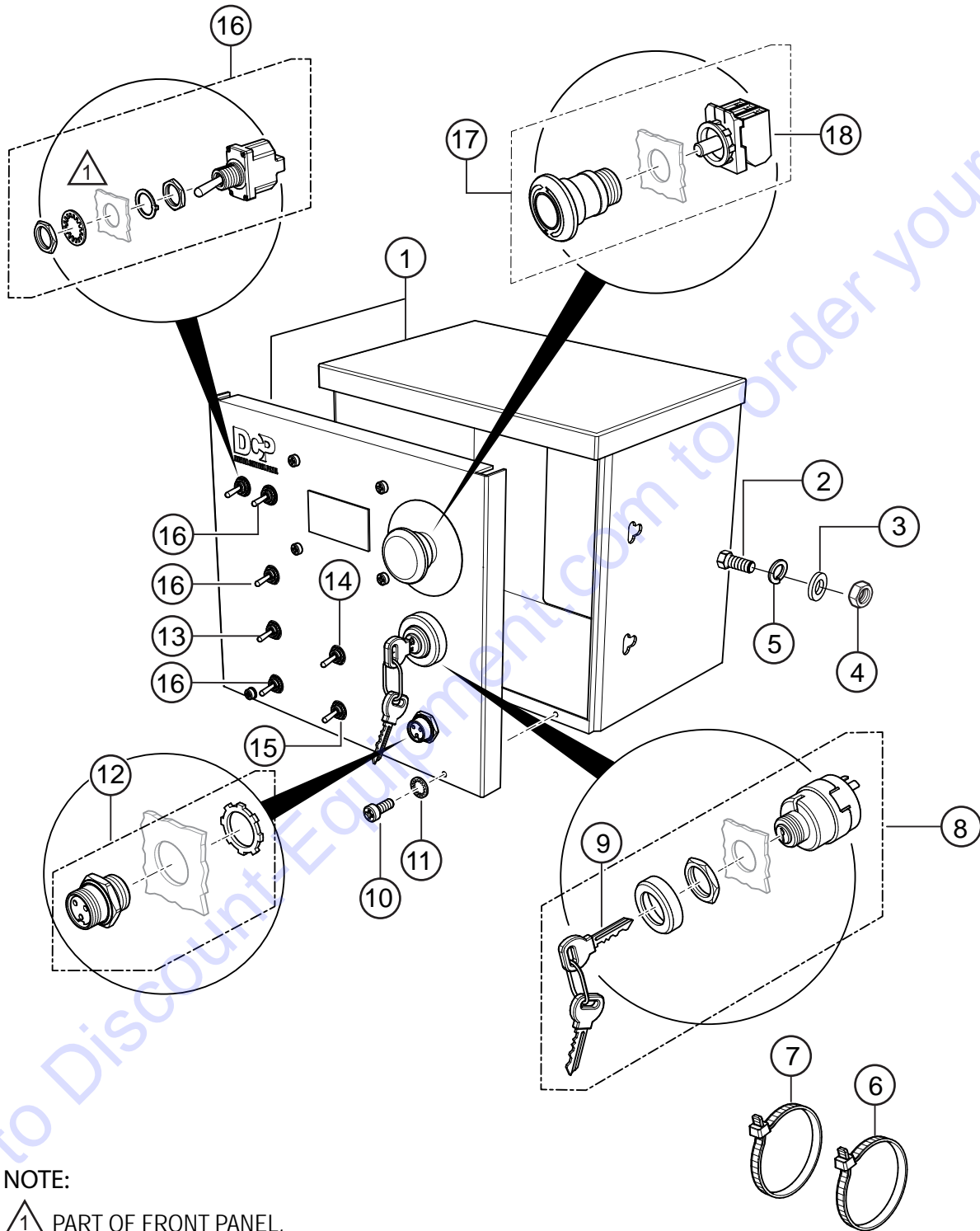

NOTE:

△ PART OF FRONT PANEL.

## CONTROL BOX ASSEMBLY

<u>NO.</u>	<u>PART NO.</u>	<u>PART NAME</u>	<u>QTY.</u>	<u>REMARKS</u>
1	EM517648A	CONTROL PANEL	1	
2	0202	SCREW, HHC 5/16"X18X1" .....	4	REPLACES P/N 492364
3	EM923023	WASHER FLAT 5/16" .....	4	REPLACES P/N 492597
4	2105164	NUT, NYLON 5/16"-18 .....	4	REPLACES P/N 492582
5	EM923343	WASHER, LOCK 5/16"	4	REPLACES P/N 492623
6	EM504505	WRAP TIE, 4.6 X 360 MM BLACK.....	2	REPLACES P/N 504505
7	EM491028	WRAP CABLE TIE, 2.5 X 95 MM, BLACK.....	5	REPLACES P/N 491028
8	EM98206	IGNITION SWITCH ASSEMBLY .....	1	INCLUDES ITEM W/\$
9\$	EM98206K	KEY, IGNITION	1	
10		SCREW.....	6	OBTAIN LOCALLY
11		WASHER .....	6	OBTAIN LOCALLY
12	EM97068	RECEPTACLE, REMOTE	1	
13	EM98120	FLOW DIRECTION SWITCH ASSY.	1	
14	EM98119	MAIN CONTROL SWITCH ASSY.	1	
15	EM98121	AUTO/JOG SWITCH ASSEMBLY	1	
16	EM98122	JOG, VOLUME, RESET, SCROLL SW. ASSY.	4	
17	EM517177	EMERGENCY STOP SWITCH ASSY.....	1	INCLUDES ITEM W/#
18#	EM517186	CONTACT BLOCK, EMERG. SWITCH	1	



# CONTROL BOX HARNESS ASSEMBLY

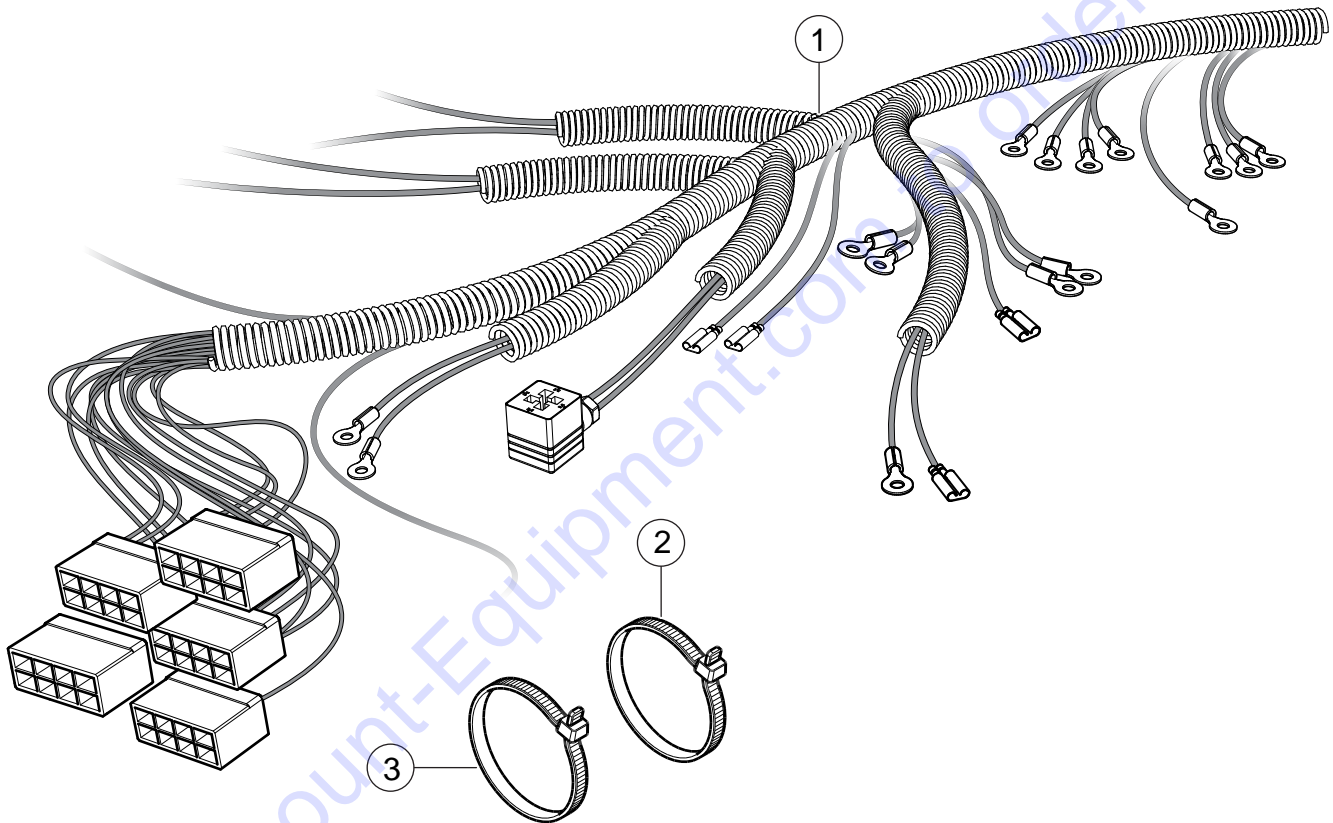

## CONTROL BOX HARNESS ASSEMBLY

---

<u>NO.</u>	<u>PART NO.</u>	<u>PART NAME</u>	<u>QTY.</u>	<u>REMARKS</u>
1	803482	WIRE HARNESS, MAIN	1	
2	491030	WRAP, TIE 2.5 X 142 MM	5	
3	EM504505	WRAP, TIE 4.6 X 360 MM	2	

Go to Discount-Equipment.com to order your parts

# REMOTE CONTROL CABLE ASSEMBLY

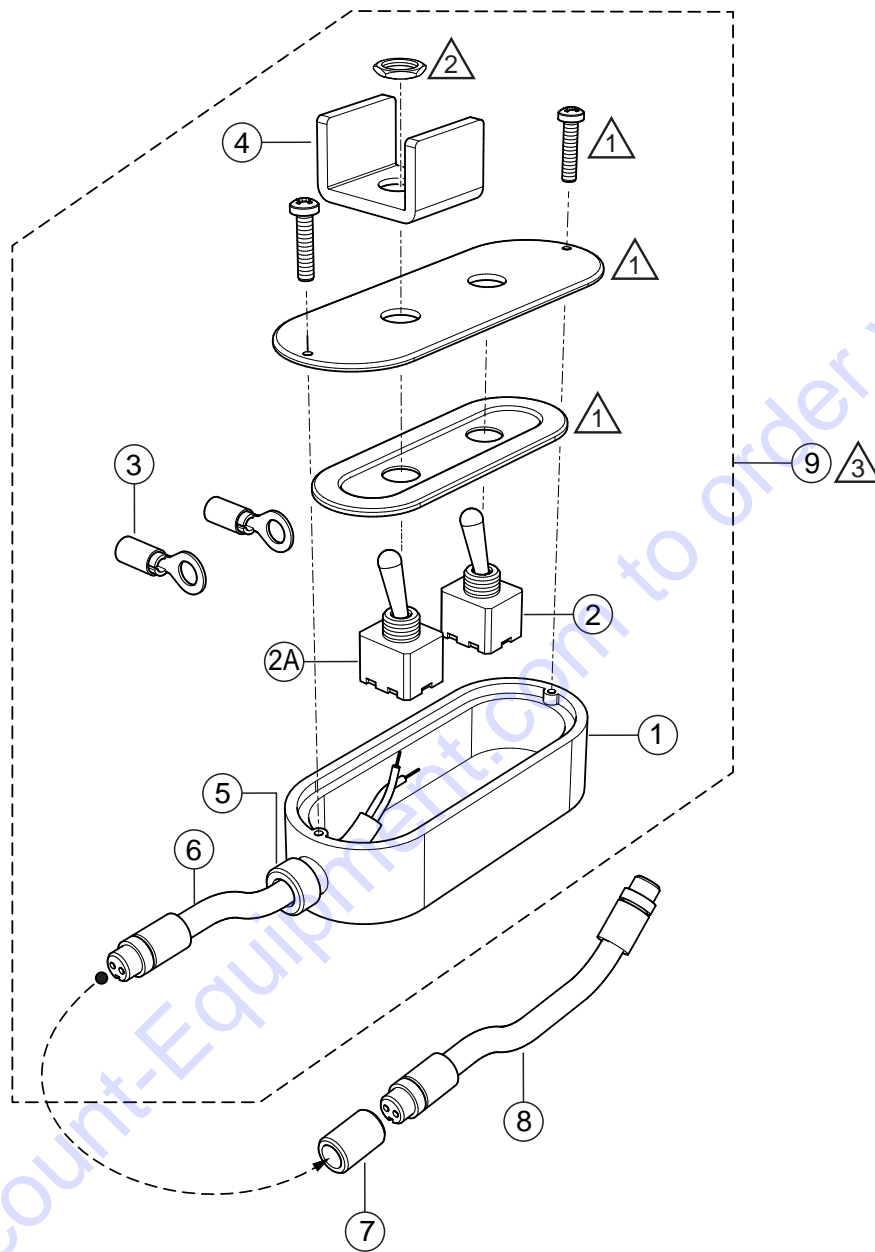

## NOTES

- ① INCLUDED WITH ITEM 1.
- ② INCLUDED WITH ITEMS 2 AND 2A.
- ③ COMPLETE CORD ASSY. INCLUDES ITEMS WITHIN DASHED LINES.

## REMOTE CONTROL CABLE ASSEMBLY

<u>NO.</u>	<u>PART NO.</u>	<u>PART NAME</u>	<u>QTY.</u>	<u>REMARKS</u>
1\$	EM16753	JUNCTION BOX	1	
2\$	EM16754	SWITCH	1	
2A\$	EM97075	SWITCH	1	
3\$	EM491897	CONNECTOR, RING 3/16"	4	
4\$	EM16756	GUARD SWITCH, ALUMINUM	2	
5\$	EM26791	SEAL, GRIP CORD	1	
6\$	EM26790	CORD, MX P/E 25 FT.	1	
7	EM26793	ADAPTER, CORD GRIP 1/2"	1	
8	EM97065	CORD, 100 FT., REMOTE CONTROL.....	1.....	OPTION
9	EM97099	CABLE REMOTE CONTROL ASSY., 25 FT.....	1.....	INCLUDES ITEMS W/\$

Go to Discount-Equipment.com to order your parts

# FUSES AND RELAYS ASSEMBLY

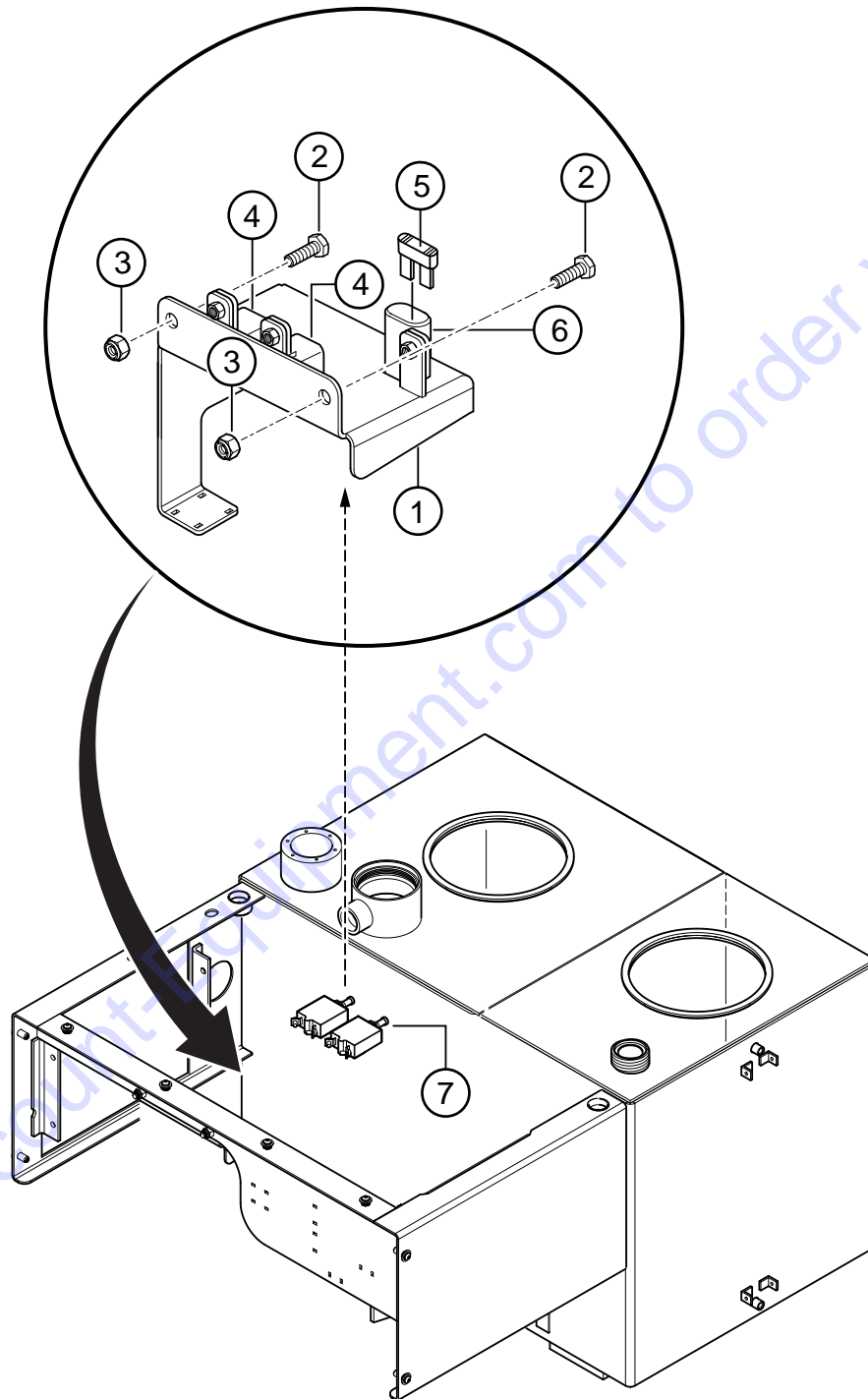

## FUSES AND RELAYS ASSEMBLY

<u>NO.</u>	<u>PART NO.</u>	<u>PART NAME</u>	<u>QTY.</u>	<u>REMARKS</u>
1	803614	SUPPORT	1	
2	492311	SCREWS	3	
3	EM969013	NUT, NYLOC.....	3.....	REPLACES P/N 492583
4	EM802515	RELAY, 80 AMP., PRE-HEAT/FAN PWR.	2	
5	23284-300	FUSE, 30 AMP., ATC/ATO	1	
6	EM98066	FUSE HOLDER, 30 AMP. MAIN	1	
7	804996	CIRCUIT BREAKER, 40 AMP.	2	

Go to Discount-Equipment.com to order your parts

# PARTS FINDER

**Search Website  
by Part Number**



**Search Manual  
Library For Parts  
Manual & Lookup Part  
Numbers – Purchase  
or Request Quote**

**Search Manuals**

Enter your information to help us find the right parts manual for your machine.

\* Brand:

\* Model:

\* Serial:

\* Part Number:

SEARCH

**Can't Find Part or  
Manual? Request Help  
by Manufacturer,  
Model & Description**

**Parts Order Form**

Please fill in the following information to help us find the right part for your machine.

Manufacturer:

Model:

Description:

Quantity:

Part Number:

Part Name:

Part Description:

Part Category:

Part Location:

Part Status:

Part Condition:

Part Material:

Part Color:

Part Weight:

Part Dimensions:

Part Price:

Part Lead Time:

Part Availability:

Part Notes:

Submit

Discount-Equipment.com is your online resource for quality parts & equipment.

Florida: **561-964-4949** Outside Florida TOLL FREE: **877-690-3101**

**Need parts?**

Click on this link: <http://www.discount-equipment.com/category/5443-parts/> and choose one of the options to help get the right parts and equipment you are looking for. Please have the machine model and serial number available in order to help us get you the correct parts. If you don't find the part on the website or on one of the online manuals, please fill out the request form and one of our experienced staff members will get back to you with a quote for the right part that your machine needs.

We sell worldwide for the brands: Genie, Terex, JLG, MultiQuip, Mikasa, Essick, Whiteman, Mayco, Toro Stone, Diamond Products, Generac Magnum, Airman, Haulotte, Barreto, Power Blanket, Nifty Lift, Atlas Copco, Chicago Pneumatic, Allmand, Miller Curber, Skyjack, Lull, Skytrak, Tsurumi, Husquvarna Target, Stow, Wacker, Sakai, Mi-T-M, Sullair, Basic, Dynapac, MBW, Weber, Bartell, Bennar Newman, Haulotte, Ditch Runner, Menegotti, Morrison, Contec, Buddy, Crown, Edco, Wyco, Bomag, Laymor, EZ Trench, Bil-Jax, F.S. Curtis, Gehl Pavers, Heli, Honda, ICS/PowerGrit, IHI, Partner, Imer, Clipper, MMD, Koshin, Rice, CH&E, General Equipment, Amida, Coleman, NAC, Gradall, Square Shooter, Kent, Stanley, Tamco, Toku, Hatz, Kohler, Robin, Wisconsin, Northrock, Oztec, Toker TK, Rol-Air, APT, Wylie, Ingersoll Rand / Doosan, Innovatech, Con X, Ammann, Mecalac, Makinex, Smith Surface Prep, Small Line, Wanco, Yanmar