



LS Series

Remix Shaft Installation Instructions



www.discount-equipment.com

REQUIRED TOOLS

- 3/8", 3/16", 1/2" Allen Wrenches
- 3/4" Combination Wrench
- 3/4" Socket w/ 3/8" Ratchet
- 3/8" Extension (6-inches)
- 3/8" Pivot Ratchet
- 7/8" Open-End Wrench
- Small Pry Bar (2)
- Flat Head Screwdriver
- Hammer, Ball-Pean
- Snap Ring Pliers (Standard Heavy Duty)
- Snap Ring Pliers (Light Duty)
- Loctite #242 Blue
- Electric Drill w/15/64" Drill Bit

PARTS

Verify that all parts are accounted for. See Figure 1 and Table 1.

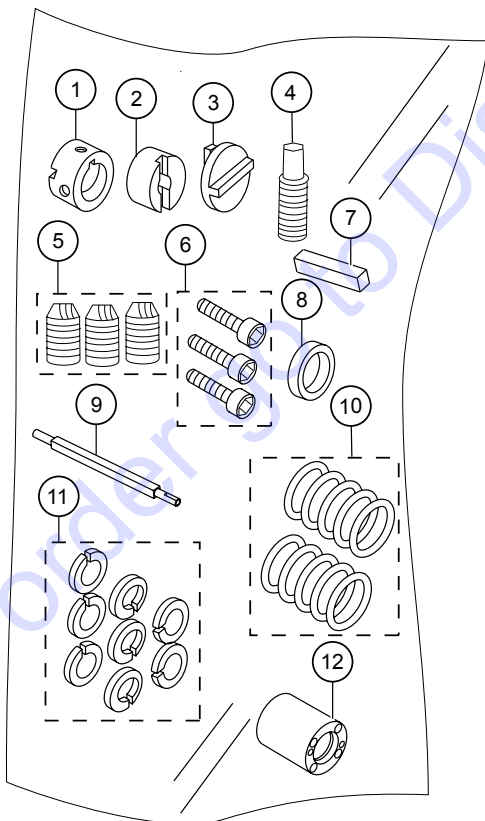

Figure 1. Remix Shaft Installation Parts

Table 1. Remix Shaft Installation Parts

Item No.	Part No.	Description	QTY.	Remarks
1	516775	Motor Shaft Coupling	1	
2	516787	Remixer Shaft Coupling	1	
3	516776	Drive Member Coupling (Thin Union)	1	
4	702	3/8" Dog Point Allen Head Set Screw	1	
5	492470	3/8" Standard Allen Head Set Screw	3	
6	EM511428	Allen Head Bolt, 1/2 x 3-1/2	4	
7	EM500264	Square Key 3/8" x 30mm	1	
8	EM516799	6mm Spacer	1	
9	EM516779	Remixer Shaft	1	
10	EM516820	Compression Springs	2	
11	EM200301	Graphite Seals	8	
12	EM516780	Bearing Housing	1	

WORK SAFELY!

Only a **qualified service technician** with proper training in hydraulics should perform this installation. Follow all shop safety rules when performing this installation.

PREPARATION/SAFETY PROCEDURES

Perform the following before attempting to install the remix shaft:

1. Place the machine on level secure ground that is free of dirt and debris.
2. Wear safety glasses; steel toed boots and any other safety protection that might be required for the modification.
3. Disconnect the negative battery cable from the battery.
4. Remove the ignition key from the switch.
5. Verify that all pressure gauges read zero.

NOTICE



NEVER! open the hydraulic lines or loosen fittings while the engine is running! Hydraulic fluid under pressure (**hot!**) can penetrate skin causing severe burns, eye injuries and other potentially dangerous hazards. **ALWAYS** follow safety guidelines.

DISASSEMBLY OF HOPPER REMIX SHAFT AND COMPONENTS

The following instructions are for the disassembly of the hopper remix shaft and components from the concrete pump. Refer to Figure 2.

1. Using a 5/8" and 9/16" size wrenches, remove the four bolts (**ITEM 1**) and associated hardware that secures the hopper grate to the hopper.

NOTICE

Some units may only have two bolts.

2. Remove the six paddle arms (**ITEM 2**) from the remixer shaft (**ITEM 12**) using a 3/4" wrench.

NOTICE

Mark the orientation of each paddle arm for reassembly.

3. Using a 7/8" wrench, remove the two hydraulic hoses (**ITEM 3**) located on the hydraulic motor. Cap or plug the open ports on both of the hydraulic motor and hoses to prevent dirt and contamination from entering the hydraulic system.

NOTICE

It may not be necessary to disconnect the hydraulic hose line.

4. Using a 3/8" wrench, remove the two hydraulic motor attachment bolts and washers (**ITEM 4**) that secure the motor to the hopper. Remove the hydraulic motor by placing two pry bars in front of the motor flange and pry backwards.
5. On the hydraulic motor side of the hopper, remove the shaft set collar (**ITEM 5**). Discard the shaft set collar as it will not be used again.
6. Using snap ring pliers (small), remove the shaft snap ring (**ITEM 6**) from the remixer shaft. Discard the snap ring as it will not be used again.

7. Using a 1/2" allen head wrench, remove the four bolts (**ITEM 7**) from the bearing support assembly (**ITEM 8**). Remove the bearing assembly with puller or by placing pry bars between the hopper and housing slowly prying backwards.

NOTICE

Discard the four bolts as they will not be used again.

8. On the hydraulic motor side of the hopper, using snap ring pliers (large), remove and retain bearing snap ring (**ITEM 8A**) from the bearing support housing. Next, use a light press or brass punch and remove the bearing (**ITEM 8B**) from the bearing support housing. Retain this bearing. Take care not to damage bearing. Discard the bearing support housing (**ITEM 8C**) as it will not be used again.

NOTICE

ITEMS 8A and 8B will be installed on the new remixer shaft.

9. On the opposite side of the hopper (no hydraulic motor), remove the end cap (**ITEM 9**). To remove the end cap, use two pry bars and slightly pry backwards to remove.
10. Again, on the opposite side of the hopper (no hydraulic motor), remove the shaft set collar (**ITEM 10**), and bearing support assembly (**ITEM 11**).

NOTICE

Remove bearing from bearing housing.

11. Remove the remixer paddle shaft (**ITEM 12**) and all associated shaft components (**ITEM 13**) from the hopper. These components consist of graphite seals, compression springs, spring seats and steel follower rings. The compression springs, remixer paddle shaft, and graphite seals will not be used again and should be discarded.

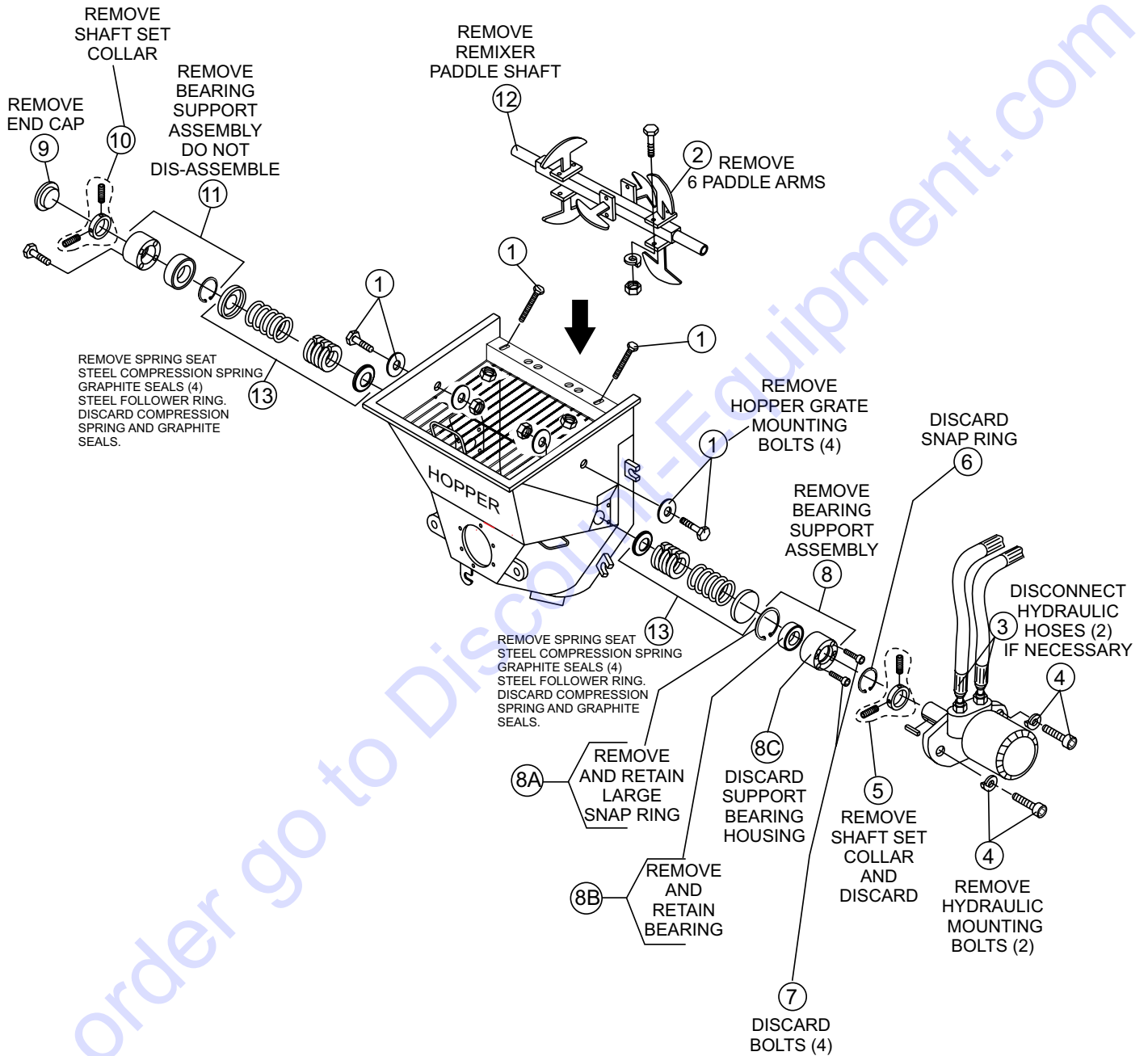

Figure 2. Disassembly of Hopper Mixer Shaft

NEW SHAFT INSTALLATION (HYDRAULIC MOTOR SIDE)

The following instructions are for the installation of the new shaft on the hydraulic motor side. Refer to Figure 3.

The new shaft installation will include the installation of the following components:

- Steel Follower Ring
- Graphite Seals (4)
- New Steel Compression Spring
- Spring Set
- Bearing Hosing/Bearing (NEW)

1. Place the **new paddle shaft (ITEM 1)** inside the hopper. The shaft end with the 3/8" key should be placed on the hydraulic motor side.
2. Starting with the hydraulic motor side of the hopper, install the **steel follower ring (ITEM 2)** into the seal box. The beveled side should face towards the inside of the hopper. The seal box is part of the hopper.
3. Liberally coat **4 graphite seals (ITEM 3)** with automotive waterproof grease.

NOTICE

Only four graphite seals are required per each side of the hopper, making a total of six seals for an entire hopper.

4. Using a flat-blade screwdriver carefully install the first seal (**ITEM 4**) into the seal box. Make sure the angle groove of the seal (cut) does not overlap. Both ends of the seal should be flush. Next, install the second seal, the (cut) groove should be placed 180° opposite the first seal. Next, install the third seal, the angle (cut) to be placed 90° from the second seal. Fill the remaining cavity area with extra grease.

NOTICE

All four seal angle cuts should be staggered from one another and should not line up.

5. Install the **new compression spring (ITEM 5)** into the seal cavity.

NOTICE

The new compression spring tension has less tension than the old one. This reduction in spring tension will increase seal life.

6. Next, install the **spring seat (ITEM 6)** making sure the seat side (indentation) is facing the compression spring.
7. Install the **new replacement bearing housing (ITEM 7)** on the hydraulic motor side. Place existing bearing (**ITEM 7A**) into bearing housing by pressing or lightly tapping into position. Take care not to damage the bearing and make sure it is properly sealed. Using snap ring pliers (standard, heavy duty) install snap ring (**ITEM 7B**) to retain bearing inside housing.

NOTICE

The bearing and snap ring were removed earlier in the disassembly procedure.

8. Install the bearing support assembly (**ITEM 8**) over the paddle shaft. Tap bearing support assembly into position.

NOTICE

The snap ring (**ITEM 7B**) side of the bearing support assembly should face the hopper side. **IMPORTANT!**, the three small holes located on the side of the bearing support assembly, should face downward toward the ground.

9. Install the four 1/2" allen head bolts (**ITEM 9**) that secure the housing to the hopper. These four bolts should only be hand tightened at this time.

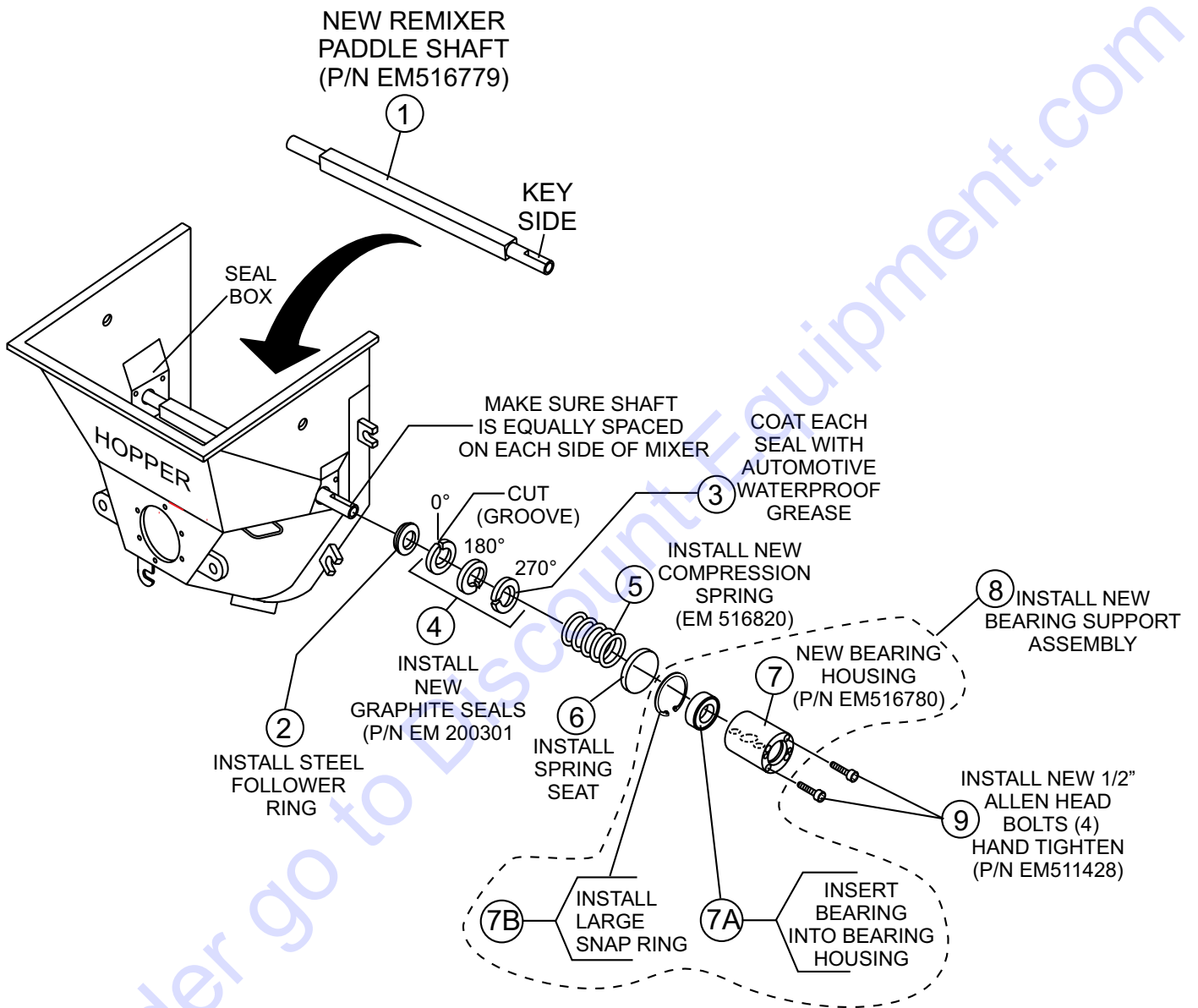

Figure 3. Hopper Side with Hydraulic Motor

NEW SHAFT INSTALLATION (SIDE WITHOUT HYDRAULIC MOTOR)

The following instructions are for the installation of the new shaft on the side without the hydraulic motor. Refer to Figure 4.

The new shaft installation will include the installation of the following components:

- Steel Follower Ring
- Graphite Seals (4)
- New Steel Compression Spring
- Spring Set
- Bearing Hosing/Bearing (EXISTING)

1. Install the **steel follower ring (ITEM 1)** into the seal box. The beveled side should face towards
2. Starting with the hydraulic motor side of the hopper, install the **steel follower ring (ITEM 2)** into the seal box. The beveled side should face towards the inside of the hopper. The seal box is part of the hopper.
3. Liberally coat **4 graphite seals (ITEM 3)** with automotive waterproof grease.

NOTICE

Only four graphite seals are required per each side of the hopper, making a total of six seals for an entire hopper.

4. Using a flat-blade screwdriver carefully install the first seal (**ITEM 4**) into the seal box. Make sure the angle groove of the seal (cut) does not overlap. Both ends of the seal should be flush. Next, install the second seal, the (cut) groove should be placed 180° opposite the first seal. Next, install the third seal, the angle (cut) to be placed 90° from the second seal. Fill the remaining cavity area with extra grease.

NOTICE

All four seal angle cuts should be staggered from one another and should not line up.

5. Install the **new compression spring (ITEM 5)** into the seal cavity.

NOTICE

The new compression spring tension has less tension than the old one. This reduction in spring tension will increase seal life.

6. Next, install the **spring seat (ITEM 6)** making sure the seat side (indentation) is facing the compression spring.
7. Install the **new replacement bearing housing (ITEM 7)** on the hydraulic motor side. Place existing bearing (**ITEM 7A**) into bearing housing by pressing or lightly tapping into position. Take care not to damage the bearing and make sure it is properly sealed. Using snap ring pliers (standard, heavy duty) install snap ring (**ITEM 7B**) to retain bearing inside housing.

NOTICE

The bearing and snap ring were removed earlier in the disassembly procedure.

8. Install the bearing support assembly (**ITEM 8**) over the paddle shaft. Tap bearing support assembly into position.

NOTICE

The snap ring (**ITEM 7B**) side of the bearing support assembly should face the hopper side. **IMPORTANT!**, the three small holes located on the side of the bearing support assembly, should face downward toward the ground.

9. Install the four 1/2" allen head bolts (**ITEM 9**) that secure the housing to the hopper. These four bolts should only be hand tightened at this time.

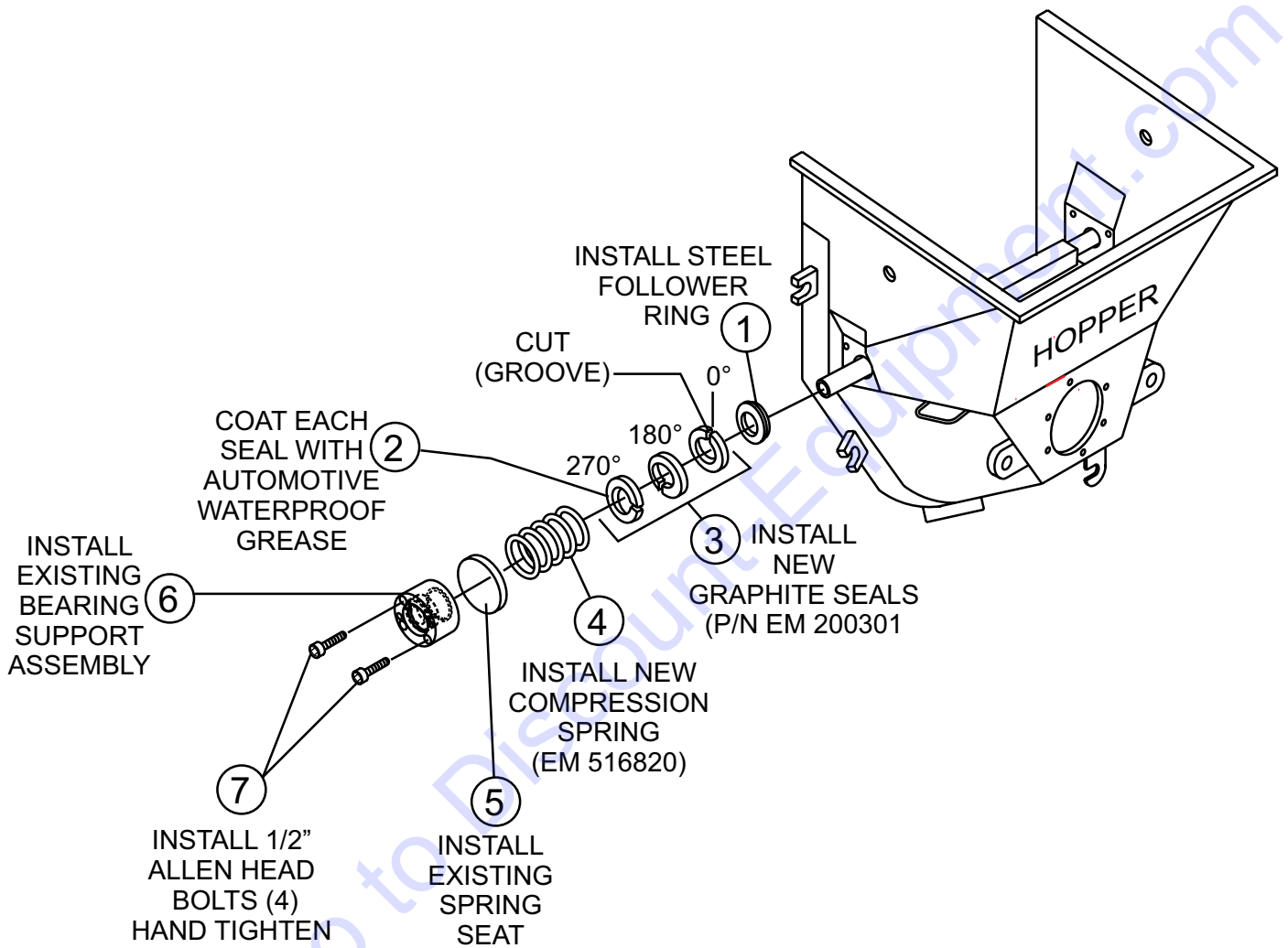

Figure 4. Hopper Side without Hydraulic Motor

REMIXER SHAFT COUPLER INSTALLATION

The following instructions are for the installation of the remixer shaft coupler. Refer to Figure 5.

NOTICE

Please note the the coupler is comprised of three individual sections. They are remixer shaft coupler, drive member coupler (thin center) and hydraulic motor shaft coupler.

1. On the hydraulic motor side hopper, place a 6 mm spacer (**ITEM 1**) onto the remixer shaft.
2. Install the remixer shaft coupler (**ITEM 2**) onto the remixer shaft.

NOTICE

Use a crescent wrench to rotate the remixer shaft until the remixer shaft coupler set screw holes are facing downward.

3. Slowly tap the remixer shaft coupling onto the remixer shaft until the coupler set screw holes becomes visible through the two holes located on the bearing support assembly. It may be necessary to slightly move (tap) the shaft laterally. **DO NOT** install the coupler too deep onto the shaft. The end of the shaft must be even or slightly below the bottom of the coupler groove. After the coupler has been positioned correctly, tap 3/8" key (**ITEM 3**) into position.

4. Once the coupler has been properly aligned onto the remixer shaft, using the two holes on the bearing support assembly (holes on remixer shaft coupler should be aligned) as a guide, drill one hole into the remixer shaft 1/4" deep using a 15/64" drill bit. This hole will counter sink the dog point set screw.

NOTICE

Use the hole closest the hopper on the bearing support assembly when drilling the hole. **DO NOT** drill into the keyway.

5. Using an allen wrench, insert a 3/8" **dog point** set screw through the left most hole on the bearing support assembly. Apply Loctite # 242 Blue to set screw and tighten securely.
6. Using an allen wrench, insert a 3/8" **standard** set screw through the right most hole on the bearing support assembly. Apply Loctite # 242 Blue to set screw and tighten securely.

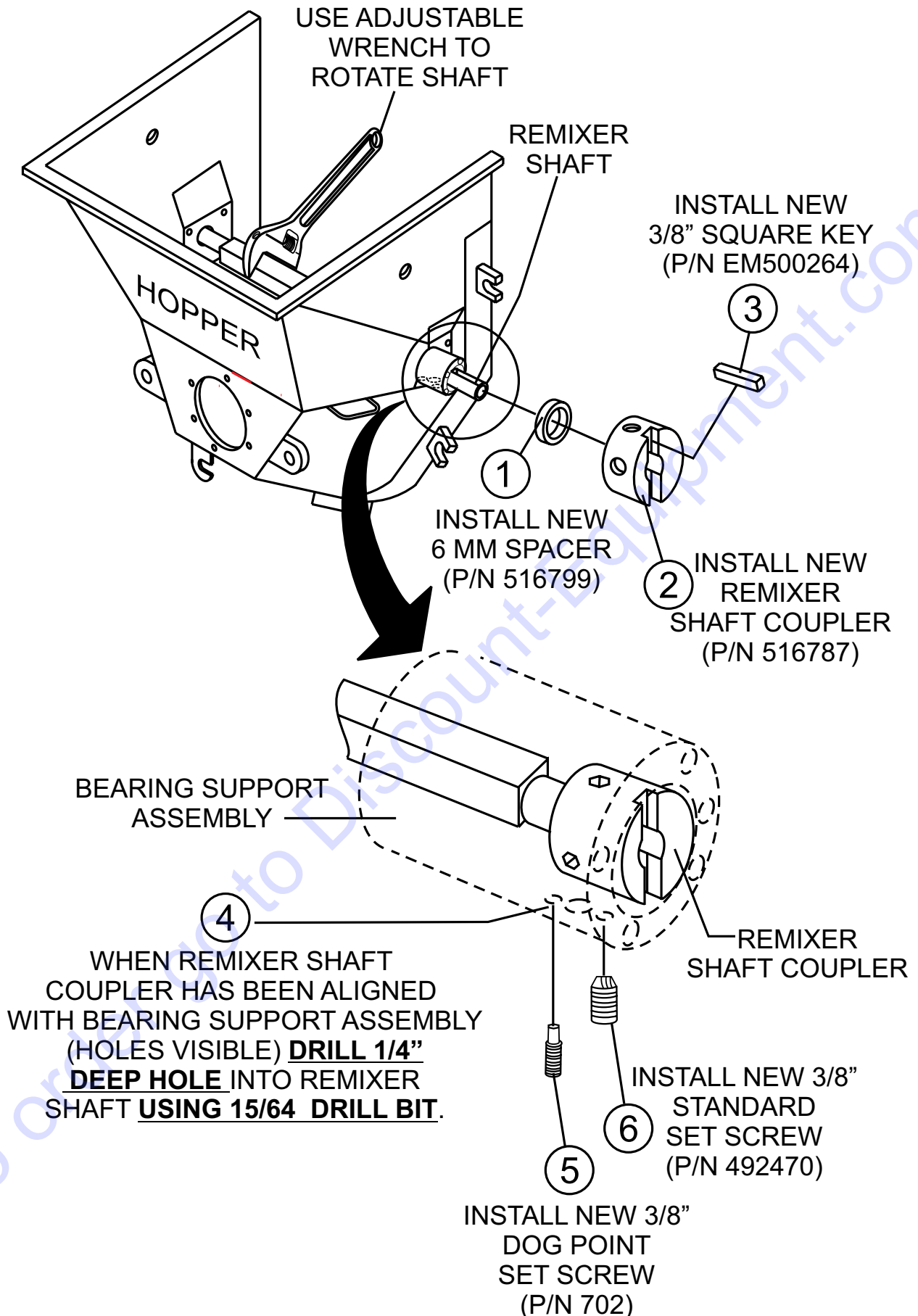

Figure 5. Remixer Shaft Coupler Installation

HYDRAULIC MOTOR SHAFT COUPLER INSTALLATION

The following instructions are for the installation of the hydraulic motor shaft coupler. Refer to Figure 6.

1. Place hydraulic motor shaft coupler (**ITEM 1**) onto the hydraulic motor shaft. Again make sure the coupling is not placed too deep. The hydraulic motor shaft should be even or below the bottom groove of the coupler.
2. Insert and install 3/8" square key (**ITEM 2**).
3. Using an allen wrench, insert two 3/8" set screws (**ITEM 3**) into the hydraulic motor shaft coupler. Apply Loctite # 242 Blue to each set screw and tighten securely.

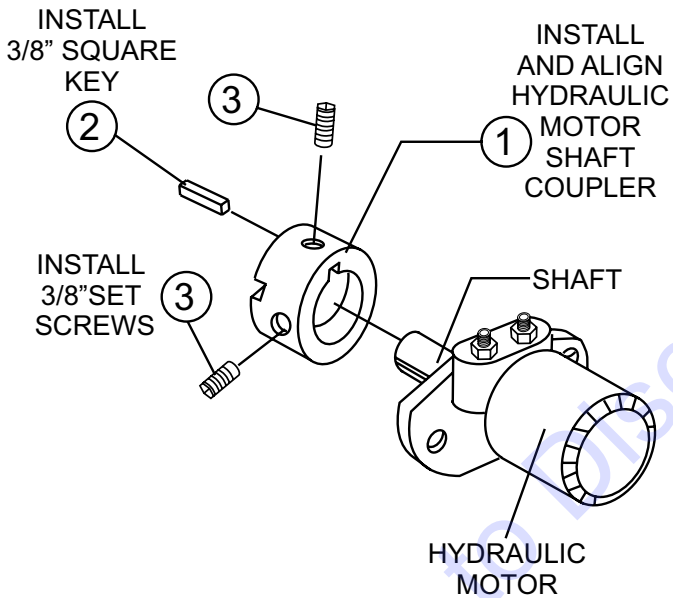

Figure 6. Hydraulic Motor Shaft Coupler Installation

HYDRAULIC MOTOR MOUNTING INSTALLATION

The following instructions are for the installation of the hydraulic motor shaft coupler. Refer to Figure 7.

1. Insert and align the keyway on the drive member coupler (**ITEM 1**) with the slotted groove on the remixer shaft coupler (**ITEM 1A**). Make sure the keyway on the drive member coupler is seated correctly and not skewed.
2. Next, align the slot on the hydraulic motor shaft coupler (**ITEM 2**), with the keyway on the drive member coupler (**ITEM 1**). All couplers are keyed or slotted and must be aligned in order to fit correctly.
3. To secure the hydraulic motor to the hopper, install and tighten the two 3/8" hydraulic motor bolts (**ITEM 3**).
4. To check coupling alignment, use a flashlight and look through the large center hole (**ITEM 4**) at the bottom of the bearing support assembly to verify that the coupler drive member (thin center coupler) has been mated correctly and is not misaligned.

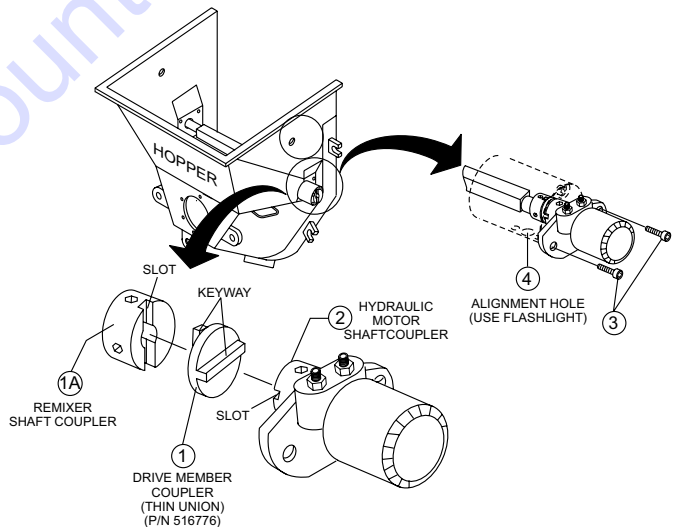

Figure 7. Remixer Shaft Coupler Installation

END CAP AND PADDLE ARM INSTALLATION

The following instructions are for the installation of the end cap and paddle arm. Refer to Figure 8.

1. On the opposite side of the hopper (no hydraulic motor), install the set collar (**ITEM 1**) onto the remixer shaft securing with standard 3/8" set screws (**ITEM 1A**). Apply Loctite # 242 Blue to each set screw and tighten securely.
2. Install end cap (**ITEM 2**), use a hammer to slightly tap end cap into place.
3. Place the four paddle arms onto the remixer shaft. Secure paddle arms to remixer shaft using mounting hardware in disassembly procedure.

NOTICE

The orientation (placement) of the paddle arms should have been marked during disassembly.

4. Place hopper grate (**ITEM 4**) onto the hopper. Using 5/8" and 9/16" size wrenches, secure hopper grate to hopper using the four bolts and associated hardware (**ITEM 4A**) removed in disassembly procedure.

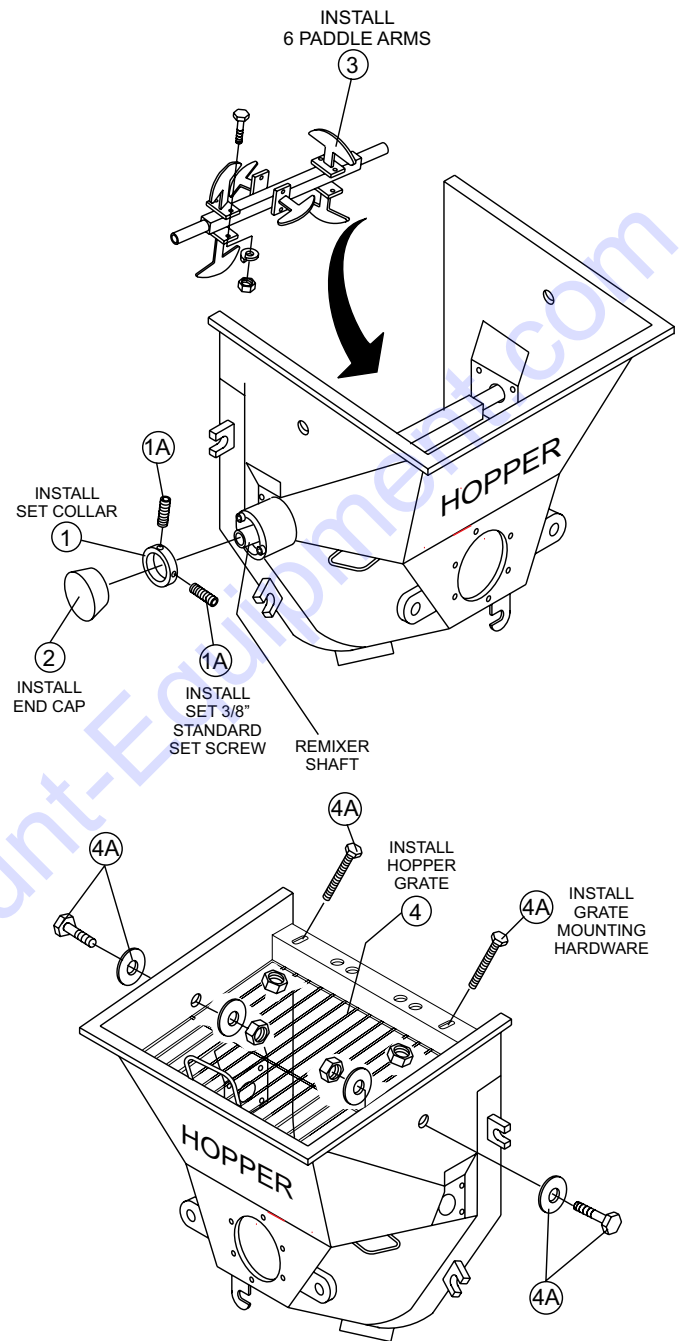

Figure 8. Set Collar and Paddle Shaft Installation

CHECKING PADDLE SHAFT ROTATION

1. **DANGER!** Use extreme caution before proceeding. Make sure all personnel are clear of the hopper area. **DO NOT** place hands inside of hopper.
2. Follow the operating procedures found within the "Operation Manual."
3. Place the remixer directional control lever in the "**neutral**" position.
4. Start engine.
5. Place the remixer directional control lever to the "**forward**" position (mix).
6. Paddle shaft arms should be rotating.
7. Place the remixer directional control lever in the "**neutral**" position.
8. Stop engine.

CHECKING FOR PROPER REMIX HYDRAULIC MOTOR OPERATING PRESSURE SETTING

1. Install (liquid filled) hydraulic 3000+ pressure gauge into remix directional valve test port fitting.
2. **DANGER!** Use extreme caution before proceeding. Make sure all personnel are clear of the hopper area. **DO NOT** place hands inside of hopper.
3. Follow the operating procedures found within the "Operation Manual."
4. Place the remixer directional control lever in the "**neutral**" position.
5. Place the control switch on the control box in the "**OFF**" position (center). The main hydraulic cylinders "**S**" tube should not move
6. Place the automatic switch on the control box in the "**OFF**" position (center).
7. Lift the grate and wedge a heavy steel pipe between the remixer paddles and the hopper, locking the paddles into a fixed position preventing rotation.
8. Start the engine.
9. Place the remixer directional control lever to the "**forward**" position (mix). With the remixer paddles locked, the remix relief valve operating pressure should read maximum 850 psi. If exceeding 850 psi, adjust relief valve.
10. Remove steel pipe from the hopper.
11. Close hopper grate.



www.discount-equipment.com

TO PURCHASE THIS PRODUCT PLEASE CONTACT US



**Equipment Financing and
Extended Warranties Available**



**Discount-Equipment.com is your online resource for
commercial and industrial quality parts and equipment sales.**

561-964-4949

visit us on line @ www.discount-equipment.com

Select an option below to find your Equipment

Search by Manufacturer

Search by Product Type

Request a Quote

We sell worldwide for the brands: Genie, Terex, JLG, MultiQuip, Mikasa, Essick, Whiteman, Mayco, Toro Stone, Diamond Products, Generac Magnum, Airman, Haulotte, Barreto, Power Blanket, Nifty Lift, Atlas Copco, Chicago Pneumatic, Allmand, Miller Curber, Skyjack, Lull, Skytrak, Tsurumi, Husquvarna Target, Stow, Wacker, Sakai, Mi-T-M, Sullair, Basic, Dynapac, MBW, Weber, Bartell, Bennar Newman, Haulotte, Ditch Runner, Menegotti, Morrison, Contec, Buddy, Crown, Edco, Wyco, Bomag, Laymor, EZ Trench, Bil-Jax, F.S. Curtis, Gehl Pavers, Heli, Honda, ICS/PowerGrit, IHI, Partner, Imer, Clipper, MMD, Koshin, Rice, CH&E, General Equipment, Amida, Coleman, NAC, Gradall, Square Shooter, Kent, Stanley, Tamco, Toku, Hatz, Kohler, Robin, Wisconsin, Northrock, Oztec, Toker TK, Rol-Air, APT, Wylie, Ingersoll Rand / Doosan, Innovatech, Con X, Ammann, Mecalac, Makinex, Smith Surface Prep, Small Line, Wanco, Yanmar