



An Oshkosh Corporation Company



www.Discount-Equipment.com

Service & Maintenance Manual

**Model
260MRT**

3121108

August 14, 2018 - Rev N

ANSI

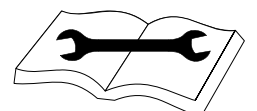

PARTS FINDER

**Search Website
by Part Number**



**Search Manual
Library For Parts
Manual & Lookup Part
Numbers – Purchase
or Request Quote**

Search Manuals

Enter your search criteria to find the manual you need for your parts.

* Brand:

* Model:

* Serial:

* Part Number:

SEARCH

**Can't Find Part or
Manual? Request Help
by Manufacturer,
Model & Description**

Parts Order Form

Please fill in the following information to request help finding a part or manual.

Manufacturer:

Model:

Description:

Part Number:

Quantity:

Submit

Discount-Equipment.com is your online resource for quality parts & equipment.

Florida: **561-964-4949** Outside Florida TOLL FREE: **877-690-3101**

Need parts?

Click on this link: <http://www.discount-equipment.com/category/5443-parts/> and choose one of the options to help get the right parts and equipment you are looking for. Please have the machine model and serial number available in order to help us get you the correct parts. If you don't find the part on the website or on once of the online manuals, please fill out the request form and one of our experienced staff members will get back to you with a quote for the right part that your machine needs.

We sell worldwide for the brands: Genie, Terex, JLG, MultiQuip, Mikasa, Essick, Whiteman, Mayco, Toro Stone, Diamond Products, Generac Magnum, Airman, Haulotte, Barreto, Power Blanket, Nifty Lift, Atlas Copco, Chicago Pneumatic, Allmand, Miller Curber, Skyjack, Lull, Skytrak, Tsurumi, Husquvarna Target, , Stow, Wacker, Sakai, Mi-T- M, Sullair, Basic, Dynapac, MBW, Weber, Bartell, Bennar Newman, Haulotte, Ditch Runner, Menegotti, Morrison, Contec, Buddy, Crown, Edco, Wyco, Bomag, Laymor, Barreto, EZ Trench, Bil-Jax, F.S. Curtis, Gehl Pavers, Heli, Honda, ICS/PowerGrit, IHI, Partner, Imer, Clipper, MMD, Koshin, Rice, CH&E, General Equipment, ,AMida, Coleman, NAC, Gradall, Square Shooter, Kent, Stanley, Tamco, Toku, Hatz, Kohler, Robin, Wisconsin, Northrock, Oztec, Toker TK, Rol-Air, Small Line, Wanco, Yanmar

SECTION A. INTRODUCTION - MAINTENANCE SAFETY PRECAUTIONS

GENERAL

This section contains the general safety precautions which must be observed during maintenance of the aerial platform. It is of utmost importance that maintenance personnel pay strict attention to these warnings and precautions to avoid possible injury to themselves or others, or damage to the equipment. A maintenance program must be followed to ensure that the machine is safe to operate.

⚠ WARNING

MODIFICATION OR ALTERATION OF AN AERIAL WORK PLATFORM SHALL BE MADE ONLY WITH WRITTEN PERMISSION FROM THE MANUFACTURER.

The specific precautions to be observed during maintenance are inserted at the appropriate point in the manual. These precautions are, for the most part, those that apply when servicing hydraulic and larger machine component parts.

Your safety, and that of others, is the first consideration when engaging in the maintenance of equipment. Always be conscious of weight. Never attempt to move heavy parts without the aid of a mechanical device. Do not allow heavy objects to rest in an unstable position. When raising a portion of the equipment, ensure that adequate support is provided.

⚠ WARNING

SINCE THE MACHINE MANUFACTURER HAS NO DIRECT CONTROL OVER THE FIELD INSPECTION AND MAINTENANCE, SAFETY IN THIS AREA RESPONSIBILITY OF THE OWNER/OPERATOR.

HYDRAULIC SYSTEM SAFETY

It should be noted that the machines hydraulic systems operate at extremely high potentially dangerous pressures. Every effort should be made to relieve any system pressure prior to disconnecting or removing any portion of the system.



MAINTENANCE

⚠ WARNING

FAILURE TO COMPLY WITH SAFETY PRECAUTIONS LISTED IN THIS SECTION COULD RESULT IN MACHINE DAMAGE, PERSONNEL INJURY OR DEATH AND IS A SAFETY VIOLATION.

- ENSURE REPLACEMENT PARTS OR COMPONENTS ARE IDENTICAL OR EQUIVALENT TO ORIGINAL PARTS OR COMPONENTS.
- NO SMOKING IS MANDATORY. NEVER REFUEL DURING ELECTRICAL STORMS. ENSURE THAT FUEL CAP IS CLOSED AND SECURE AT ALL OTHER TIMES.
- REMOVE ALL RINGS, WATCHES AND JEWELRY WHEN PERFORMING ANY MAINTENANCE.
- DO NOT WEAR LONG HAIR UNRESTRAINED, OR LOOSE-FITTING CLOTHING AND NECKTIES WHICH ARE APT TO BECOME CAUGHT ON OR ENTANGLED IN EQUIPMENT.
- OBSERVE AND OBEY ALL WARNINGS AND CAUTIONS ON MACHINE AND IN SERVICE MANUAL.
- KEEP OIL, GREASE, WATER, ETC. WIPED FROM STANDING SURFACES AND HAND HOLDS.
- USE CAUTION WHEN CHECKING A HOT, PRESSURIZED COOLANT SYSTEM.
- NEVER WORK UNDER AN ELEVATED SCISSOR UNTIL PLATFORM HAS BEEN SAFELY RESTRAINED FROM ANY MOVEMENT BY BLOCKING OR OVERHEAD SLING, OR SAFETY PROP HAS BEEN ENGAGED.
- BEFORE MAKING ADJUSTMENTS, LUBRICATING OR PERFORMING ANY OTHER MAINTENANCE, SHUT OFF ALL POWER CONTROLS.
- BATTERY SHOULD ALWAYS BE DISCONNECTED DURING REPLACEMENT OF ELECTRICAL COMPONENTS.
- KEEP ALL SUPPORT EQUIPMENT AND ATTACHMENTS STOWED IN THEIR PROPER PLACE.
- USE ONLY APPROVED, NONFLAMMABLE CLEANING SOLVENTS.

REVISION LOG

Original Issue	A - March 27, 2000 B
Revised	- January 23, 2002 C-
Revised	April 15, 2004
Revised	D - October 21, 2004
Revised	E - July 3, 2006
Revised	F - August 30, 2006
Revised	G - October 11, 2007
Revised	H - April 28, 2008
Revised	I - Dec 19, 2008
Revised	J - October 20, 2011
Revised	K - June 8, 2012
Revised	L - April 19, 2013
Revised	N - August 14, 2018

Go to Discount-Equipment.com to order your parts

TABLE OF CONTENTS

SUBJECT - SECTION, PARAGRAPH		PAGE NO.
SECTION 1 - SPECIFICATIONS		
1.1	Operating Specifications	1-1
1.2	Capacities	1-1
1.3	Component Data	1-1
1.4	Lubrication	1-3
1.5	Lubrication Specifications	1-3
1.6	Cylinder Specifications	1-3
1.7	Pressure Settings.....	1-3
1.8	Limit Switches	1-4
1.9	Major Component Weights.....	1-4
1.10	Critical Stability Weights.....	1-4
1.11	Serial Number Locations	1-5
1.12	Torque Charts.....	1-8
SECTION 2 - PROCEDURES		
2.1	General	2-1
2.2	Servicing and Maintenance Guidelines.....	2-1
2.3	Lubrication Information	2-2
2.4	Cylinders - Theory of Operation.....	2-3
2.5	Valves - Theory of Operation.....	2-3
2.6	Component Functional Description.....	2-4
2.7	Wear Pads	2-4
2.8	Cylinder Checking Procedures	2-5
2.9	Lift Cylinder Removal and Installation.....	2-6
2.10	Cylinder Repair.....	2-10
2.11	Steer Cylinder Repair	2-15
2.12	Limit Switch Adjustment	2-21
2.13	Pressure Setting Procedures.....	2-21
2.14	Drive Pump Start-up Procedure.....	2-24
2.15	Automatic Choke - Field Adjustment (DF-750).....	2-25
2.16	Joystick Controller	2-26
2.17	Tilt Sensor	2-28
2.18	Calibrations.....	2-30
2.19	Electronic Control System	2-32
2.20	Flash Codes and Descriptions.....	2-36
2.21	Machine Model Adjustment	2-43
2.22	Machine Configuration Programming Information	2-44
2.23	Preventive Maintenance and Inspection Schedule.....	2-46
SECTION 3 - GENERAL ELECTRICAL INFORMATION & SCHEMATICS		
3.1	General	3-1
3.2	Multimeter Basics	3-1
3.3	Applying Silicone Dielectric Compound To Amp Connectors	3-5
3.4	Working With Deutsch Connectors	3-10
3.5	Switches.....	3-12
3.6	Troubleshooting	3-13
3.7	Electrical Schematics.....	3-22

LIST OF FIGURES

FIGURE NO.	TITLE	PAGE NO.
1-1.	Serial Number Location.....	1-5
1-2.	Lubrication Diagram.....	1-6
1-3.	Operating Temperature Specifications - Kubota.....	1-7
1-4.	Torque Chart (SAE Fasteners - Sheet 1 of 5).....	1-8
1-5.	Torque Chart (SAE Fasteners - Sheet 2 of 5).....	1-9
1-6.	Torque Chart (SAE Fasteners - Sheet 3 of 5).....	1-10
1-7.	Torque Chart (Metric Fasteners - Sheet 4 of 5).....	1-11
1-8.	Torque Chart (Metric Fasteners - Sheet 5 of 5).....	1-12
2-1.	Arms and Platform Positioning and Support, Cylinder Repair.....	2-7
2-2.	Lift Cylinder Removal - Cylinder Support.....	2-8
2-3.	Lift Cylinder.....	2-9
2-4.	Cylinder Barrel Support.....	2-10
2-5.	Capscrew Removal.....	2-10
2-6.	Cylinder Rod Support.....	2-10
2-7.	Tapered Bushing Removal.....	2-11
2-8.	Rod Seal Installation.....	2-12
2-9.	Wiper Seal Installation.....	2-12
2-10.	Installation of Head Seal Kit.....	2-12
2-11.	Piston Seal Kit Installation.....	2-13
2-12.	Tapered Bushing Installation.....	2-13
2-13.	Seating the Tapered Bearing.....	2-13
2-14.	Poly-Pak Piston Seal Installation.....	2-14
2-15.	Rod Assembly Installation.....	2-14
2-16.	Steer Cylinder Assembly.....	2-17
2-17.	Leveling Jack Assembly - (Prior to S/N 105371).....	2-18
2-18.	Leveling Jack Assembly - (S/N 105371 to S/N 141689).....	2-19
2-19.	Leveling Jack Assembly - (AUS Spec: S/N 128985 to Present & CE Spec: S/N 141689 to Present).....	2-20
2-20.	Valve Components.....	2-22
2-21.	Leveling Jacks Directional Valve.....	2-23
2-22.	Automatic Choke Adjustment (DF-750).....	2-25
2-23.	Joystick Controller - (JLG P/N 1600308).....	2-26
2-24.	Joystick Controller - (JLG P/N 1600403).....	2-27
2-25.	Tilt Sensor Location.....	2-28
2-26.	Tilt Sensor Removal.....	2-28
2-27.	Tilt Sensor Location.....	2-29
2-28.	Tilt Sensor Removal.....	2-29
2-29.	Hand Held Analyzer.....	2-32
2-30.	Analyzer Flow Chart - Sheet 1 of 5.....	2-38
2-31.	Analyzer Flow Chart - Sheet 2 of 5.....	2-39
2-32.	Analyzer Flow Chart - Sheet 3 of 5.....	2-40
2-33.	Analyzer Flow Chart - Sheet 4 of 5.....	2-41
2-34.	Analyzer Flow Chart - Sheet 5 of 5.....	2-42
3-1.	Voltage Measurement (DC).....	3-2
3-2.	Resistance Measurement.....	3-2
3-3.	Continuity Measurement.....	3-3
3-4.	Current Measurement (DC).....	3-3
3-5.	AMP Connector.....	3-5
3-6.	Connector Assembly (1 of 4).....	3-6
3-7.	Connector Assembly (2 of 4).....	3-6
3-8.	Connector Assembly (3 of 4).....	3-7
3-9.	Connector Assembly (4 of 4).....	3-7
3-10.	Connector Disassembly.....	3-8
3-11.	Connector Installation.....	3-9
3-12.	DT/DTP Contact Installation.....	3-10

3-13.	DT/DTP Contact Removal.....	3-10
3-14.	HD/HDP Contact Installation.....	3-10
3-15.	HD/HDP Locking Contacts Into Position.....	3-11
3-16.	HD/HDP Contact Removal.....	3-11
3-17.	HD/HDP Unlocking Contacts.....	3-11
3-18.	Electrical Schematic - Sheet 1 of 4.....	3-22
3-19.	Electrical Schematic - Sheet 2 of 4.....	3-23
3-20.	Electrical Schematic - Sheet 3 of 4.....	3-24
3-21.	Electrical Schematic - Sheet 4 of 4.....	3-25
3-22.	Electrical Schematic - (Generator) - Sheet 1 of 4.....	3-26
3-23.	Electrical Schematic - (Generator) - Sheet 2 of 4.....	3-27
3-24.	Electrical Schematic - (Generator) - Sheet 3 of 4.....	3-28
3-25.	Electrical Schematic - (Generator) - Sheet 4 of 4.....	3-29
3-26.	Electrical Components Installation - Prior to S/N 141689 - Sheet 1.....	3-30
3-27.	Electrical Components Installation - Prior to S/N 141689 - Sheet 2.....	3-31
3-28.	Electrical Components Installation - S/N 141689 to Present - Sheet 1.....	3-32
3-29.	Electrical Components Installation - S/N 141689 to Present - Sheet 2.....	3-33
3-30.	Hydraulic Schematic - Prior to S/N 141689.....	3-34
3-31.	Hydraulic Schematic - S/N 141689 to Present.....	3-35
3-32.	Hydraulic Diagram (Generator).....	3-36
3-33.	Hydraulic Diagram (Leveling Jacks).....	3-37

Go to Discount-Equipment.com to order your parts

LIST OF TABLES

TABLE NO.	TITLE	PAGE NO.
1-1	Operating Specifications	1-1
1-2	Capacities	1-1
1-3	WG750-B Kubota Gasoline/LP	1-1
1-4	WG752-E3 Kubota Gasoline/LP (Tier 3)	1-2
1-5	D905-B Kubota Diesel	1-2
1-6	D1005 Kubota Diesel	1-2
1-7	Tire Specifications	1-2
1-8	Pump Specifications	1-2
1-9	Hydraulic Oil	1-3
1-10	Lubrication Specifications	1-3
1-11	Cylinder Specifications	1-3
1-12	Pressure Settings	1-3
1-13	Major Component Weights	1-4
1-14	Critical Stability Weights	1-4
1-15	Lubrication Chart	1-6
2-1	Cylinder Component Torque Specifications	2-14
2-2	Holding Valve Torque Specifications	2-14
2-3	Leveling Jacks Directional Valve Torque Specs	2-23
2-4	Joystick Specifications	2-26
2-5	Joystick Plug Loading Chart	2-26
2-6	Joystick Specifications	2-27
2-7	Joystick Plug Loading Chart	2-27
2-8	Tilt Sensor Harness Chart	2-28
2-9	Tilt Sensor Harness	2-29
2-10	Help Messages and Flash Codes - Software P1.X	2-36
2-11	Machine Model Adjustment	2-43
2-12	Machine Configuration Programming Information - Software Version 13.1	2-44
2-13	Machine Configuration Programming Information - Software Version P1.13	2-45
2-14	Preventive Maintenance and Safety Inspection	2-47
3-1	Elevation System Troubleshooting	3-14
3-2	Chassis Troubleshooting	3-16
3-3	Hydraulic System Troubleshooting	3-19
3-4	Electrical System Troubleshooting	3-20

SECTION 1. SPECIFICATIONS

1.1 OPERATING SPECIFICATIONS

Table 1-1. Operating Specifications

Machine Weight	7330 lb (3324.8 kg)
Machine Height:	
Fully Elevated	26 ft (8 m)
Stowed	7.5 ft (2.3 m)
Machine Width	5.9 ft (1.8 m)
Machine Length	8.9 ft (2.7 m)
Platform Railing Height	43.5 in. (1.1 m)
Platform Dimensions	8.5 x 5.4 ft (2.59 x 1.65 m)
Platform Capacity	1250 lb (570 kg)
Platform Extension Capacity	300 lb (140 kg)
Max Travel Speed	2.8 mph (4.5 km/h)
Max Travel Grade	35%
Max Slope:	
Side to Side	3°
Fore & Aft	5°
Turning Radius:	
Inside	6.9 ft (2.1 m)
Outside	14.4 ft (4.4 m)
Lift Speed: (no load)	
Dual Fuel:	
Up	25-29 sec
Down	21-27 sec
Diesel:	
Up	32-34 sec
Down	21-27 sec
Max Tire Load	2600 lb (1180 kg)
Max Ground Bearing Pressure	33 psi (2.3 kg/cm ²)
Max Hydraulic system Pressure	3000 psi (20.68 Mpa)
Electrical System Voltage	12 Volt
Wheelbase	78 in. (2 m)
Ground Clearance	8 in. (20.3 cm)
Max Windspeed	28 mph (12.5 m/s)
Max Horizontal Manual Side Force	90 lbf (400 N)
Number of Persons	2

1.2 CAPACITIES

Table 1-2. Capacities

Fuel Tank	7.2 gal (27.2 L)
Hydraulic Oil Tank	15 gal (56.8 L)
Hydraulic System (including tank)	18 gal (68.1 L)
Engine Crankcase:	
Gasoline Engine	3.4 qts (3.25 L)
Diesel Engine	4.2 qts (4 L)
Engine Coolant:	
Gasoline Engine	1.25 gal (4.7 L)
Diesel Engine	1.5 gal (5.7 L)

1.3 COMPONENT DATA

Engine

Table 1-3. WG750-B Kubota Gasoline/LP

Type	3 cylinder, liquid-cooled
Power	24.5 horsepower @ 3600 RPM
Idle	1500 RPM
High Engine	3600 RPM
Alternator	40 Amp
Fuel Consumption:	
Low RPM	1.3 gph (4.9 Lph)
High RPM	2.4 gph (9 Lph)

SECTION 1 - SPECIFICATIONS

Table 1-4. WG752-E3 Kubota Gasoline/LP (Tier 3)

Type	3 cylinder, liquid-cooled
Max Output Power	
Gas	24.8 HP (18.5 kW)@3600 RPM
LP	23.8 HP (17.7 kW) @3600 RPM
Idle RPM Set	1500 ± RPM
High RPM Set	3600 + 100/-000 RPM
Max Output Torque	
Gas	40.5 ft.lb. (54.9 Nm)@2400 RPM
LP	38.3 ft.lb. (52.0 Nm)@2400 RPM
Engine Oil Capacity	0.86 gal (3.25 L)
Engine Coolant Capacity	0.61 gal (2.3 L)
Starter Rating	12V, 0.7 kW
Alternator	12V, 40 Amp
Fuel Consumption:	
Low RPM	1.3 gph (4.9 Lph)
High RPM	2.4 gph (9 Lph)
<p>The Altitude Compensation Kit on this TIER 3 engine is set up from the factory to EPA emission standards for altitudes below 2800 ft. (700m). Kits for operating at higher altitudes are available from Kubota.</p> <p>If operating at higher altitudes without the proper kit installed, this engine will run with a rich fuel mixture and may therefore exhibit the following issues:</p> <p>Excessive exhaust temperature: This may rapidly or immediately damage the catalyst (if equipped). Engine overheating may also occur.</p> <p>Excessive soot: This will rapidly deteriorate the engine oil, the valves, and the exhaust ports with carbon deposits. If enough soot is built up the catalyst (if equipped) may not function properly.</p> <p>Emissions: Kubota cannot guarantee emissions without the proper Altitude Compensation kit installed.</p>	

Table 1-5. D905-B Kubota Diesel

Type	3 cylinder, liquid-cooled
Power	26 horsepower @ 3000 rpm
Low Idle	800 rpm
High Engine	3800 rpm
Alternator	40 Amp
Fuel Consumption:	
Low RPM	0.68 gph (2.6 Lph)
High RPM	1.48 gph (5.5 Lph)

Table 1-6. D1005 Kubota Diesel

Type	3 cylinder, liquid-cooled
Power	23.5 horsepower @ 3000 RPM
Bore x Stroke	76.0 mm x 73.6 mm
Low Idle	800 RPM
High Idle	3800 RPM
Alternator	12V, 30 Amp
Starter	12V, 1.0 Amp
Fuel Consumption	1.32 Lph (0.35 gph)

Tires

Table 1-7. Tire Specifications

Description	(Standard)	(Non-Marking)
Size	26x12-15	
Load Range	8 Ply	
Pressure	55 psi	

Pumps

Table 1-8. Pump Specifications

Description	Drive Pump	Lift/Steer Pump
Type	Piston	Gear
Max Output	22 gpm (83.3 lpm) @ 3000 RPM	4.75 gpm (18 lpm) @ 3000 RPM
Displacement	1.7 in ³ /rev (28 cm ³ /rev)	0.36 in ³ /rev (1.4 cm ³ /rev)

Steer/Drive System

Tire - Pneumatic or foam filled - 26 x 12 15 lug

NOTE: Inflate pneumatic tire to 55 psi (3.8 bar)

Toe-In - Adjust to ±1/4 inch (6.4 mm) overall

Drive Motor - Rexroth

Hydraulic Filter - Inline

Full flow paper filter (Cartridge type)

Torque Requirement

All wheel lug nuts should be torqued to 105 ft lb (142 Nm) every 150 hours.

NOTE: When maintenance becomes necessary or a fastener has loosened, refer to the Torque Chart in this section to determine proper torque value.

1.4 LUBRICATION

Hydraulic Oil

NOTE: Hydraulic oils must have anti-wear qualities at least to API Service Classification GL-3, and sufficient chemical stability for mobile hydraulic system service. JLG Industries recommends Mobilfluid 424 hydraulic oil, which has an SAE viscosity of 10W-30 and a viscosity index of 152.

Table 1-9. Hydraulic Oil

HYDRAULIC SYSTEM OPERATING TEMPERATURE RANGE	SAE VISCOSITY GRADE
0°F to +23°F (-18°C -5°C)	10W
0°F to +210°F (-18°C to +100°C)	10W-20, 10W-30
+50°F to +210°F (+10°C to +100°C)	20W-20

NOTE: Aside from JLG recommendations, it is not advisable to mix oils of different brands or types, as they may not contain the same required additives or be of comparable viscosities.

1.5 LUBRICATION SPECIFICATIONS

Table 1-10. Lubrication Specifications

KEY	SPECIFICATIONS
MPG	Multipurpose Grease having a minimum dripping point of 350°F. Excellent water resistance and adhesive qualities, and being of extreme pressure type. (Timken OK 40 pounds minimum.)
EPGL	Extreme Pressure Gear Lube (oil) meeting API service classification GL-5 or MIL-Spec MIL-L-2105.
EO	Engine (crankcase) Oil. Gas - API SF/SG class, MIL-L-2104. Diesel - API CC/CD class, MIL-L-2104B/MIL-L-2104C.
HO	Hydraulic Oil. API service classification GL-3, e.g. Mobil 424.

1.6 CYLINDER SPECIFICATIONS

Table 1-11. Cylinder Specifications

Description	Bore	Stroke	Rod Dia.
Lift Cylinder	4.00 in (10.2 cm)	47 in (119.4 cm)	2.50 in (6.4 cm)
Steer Cylinder	2.00 in (5.1 cm)	7.84 in (20 cm)	1.12 in (2.8 cm)

1.7 PRESSURE SETTINGS

Table 1-12. Pressure Settings

Main Relief	3300 psi ±50 psi (234 bar ±3.4 bar)
Steer Relief - Left	2300 psi (159 bar)
Steer Relief - Right	1700 psi (117 bar)
Lift Up Relief	2300 psi (159 bar)
Leveling Jack Relief	2500 psi (207 bar)

1.8 LIMIT SWITCHES

The machine is equipped with the following limit switches:

Tilt Alarm - Illuminates a light on the platform and sounds an alarm when the machine is 3° side to side or 5° fore and aft.

High Drive Cut-Out - High drive speed is cut out when the platform is raised above the stowed position.

Max Drive Height - The drive function is cut out when the platform is raised by 7.5 - 8 ft (2.3 - 2.4 m).

1.9 MAJOR COMPONENT WEIGHTS

Table 1-13. Major Component Weights

Component	Weight
Platform	650 lb (295 kg)
Platform and Extension	1000 lb (454 kg)
Manual Platform Extension	350 lb (159 kg)
Arm Assembly (Includes Lift Cylinder)	2040 lb (925 kg)
Chassis - w/Standard Tires	4120 lb (1869 kg)

1.10 CRITICAL STABILITY WEIGHTS



WARNING

DO NOT REPLACE ITEMS CRITICAL TO STABILITY, SUCH AS ENGINES, AXLES OR TIRES, WITH ITEMS OF DIFFERENT WEIGHT OR SPECIFICATION. DO NOT MODIFY UNIT IN ANY WAY TO AFFECT STABILITY.

Table 1-14. Critical Stability Weights

Component	Weight
Tire and Wheel Assembly - Std (each)	50 lb (23 kg)
Tire and Wheel Assembly - FF (each)	152 lb (69 kg)
Kubota Gas/DF Engine (Dry with flywheel and housing)	136 lb (61.7 kg)
Kubota Diesel Engine (Dry with flywheel and housing)	256 lb (116 kg)

1.11 SERIAL NUMBER LOCATIONS

For machine identification, a serial number plate is affixed to the machine. The plate is located on the rear center of the machine frame, just below the middle step of the ladder. In addition, if the serial number plate is damaged or missing, the machine serial number is stamped on the right front frame rail, adjacent to the sizzor arms.

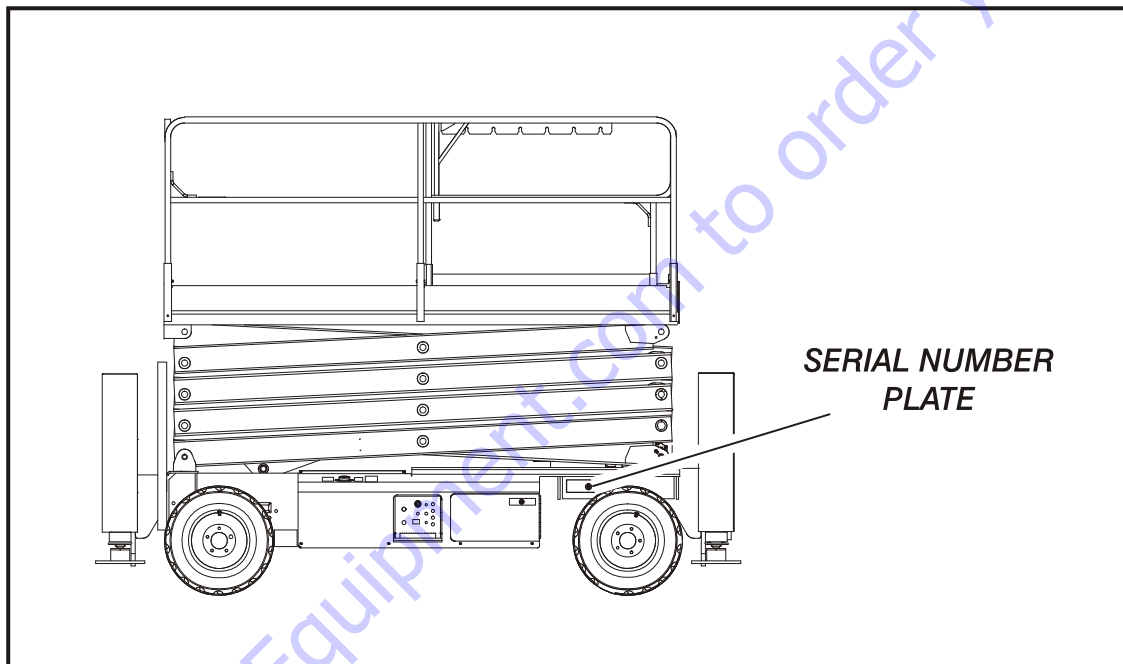

Figure 1-1. Serial Number Location

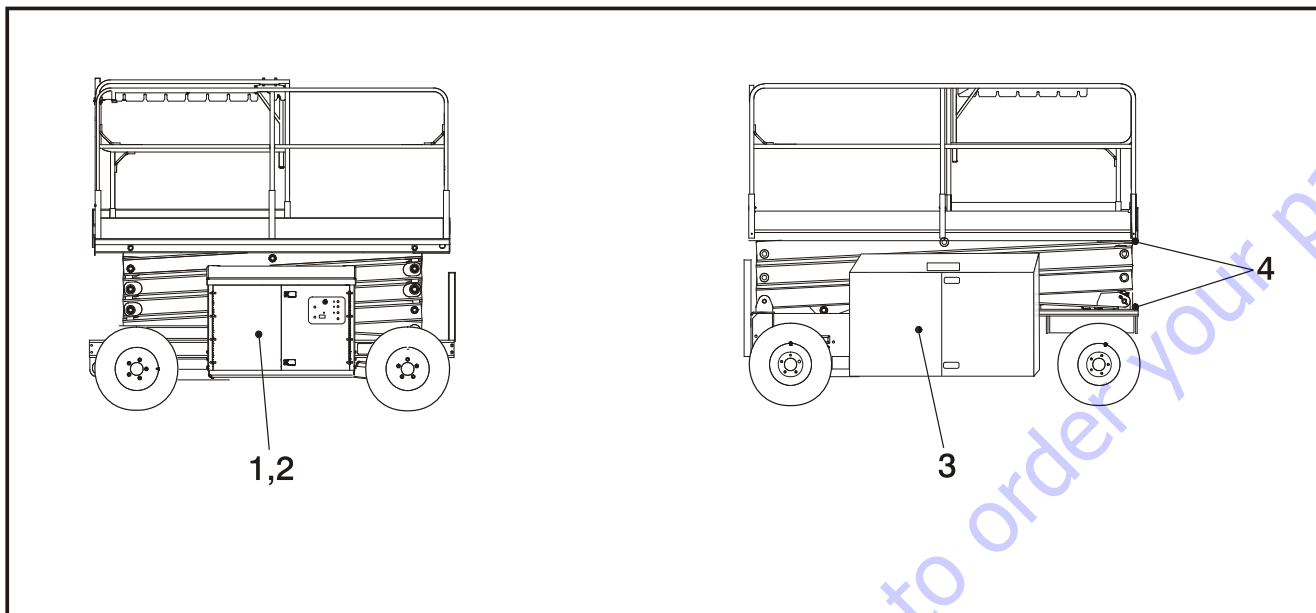

Figure 1-2. Lubrication Diagram

Table 1-15. Lubrication Chart

INDEX NO	COMPONENT	NUMBER/TYPE LUBE POINTS	LUBE METHOD	INTERVAL HOURS
1	Hydraulic Oil Reservoir	Fill Cap/Drain Plug	HO - Check HO Level HO - Change HO	10/500
2	Hydraulic Filter Element	N/A	Initial Change -50 Hours	250
3	Engine Crankcase, Engine Oil Filter, Engine Fuel Filter, Engine Fuel Filter (Kubota DF752)	Fill Cap/Drain Plug, Filter Element, Filter Element, Filter Element	Check Engine Oil Level, Initial Change - 50 Hours, Check & Clean every 100 hrs, Check & Clean every 100 hrs	10/100, 200, 400, Yearly
4	Rail Slides	N/A	MPG - Brush	100

KEY TO LUBRICANTS:

MPG - Multi-purpose Grease

EPGL - Extreme Pressure Gear Lube

HO - Hydraulic Oil (Mobil 424)

⚠ WARNING

TO AVOID PERSONAL INJURY, USE SAFETY PROP FOR ALL MAINTENANCE REQUIRING PLATFORM TO BE ELEVATED.

NOTE: Be sure to lubricate like items on each side.

Recommended lubricating intervals are based on machine operations under normal conditions. For machines used in multi-shift operations and/or exposed

to hostile environments or conditions, lubrication frequencies must be increased accordingly.

NOTE: Operate hydraulic functions through one complete cycle before checking hydraulic oil level in tank. Oil should be visible in ADD sight window on hydraulic tank. If oil is not visible, add oil until oil is visible in both ADD and FULL sight windows on tank. Do not overfill tank.

Any time the pump coupling is removed, coat splines of coupling with Texaco Code 1912 grease prior to assembly.

OPERATING TEMPERATURE SPECIFICATION - KUBOTA (GAS [*] & DIESEL[#])

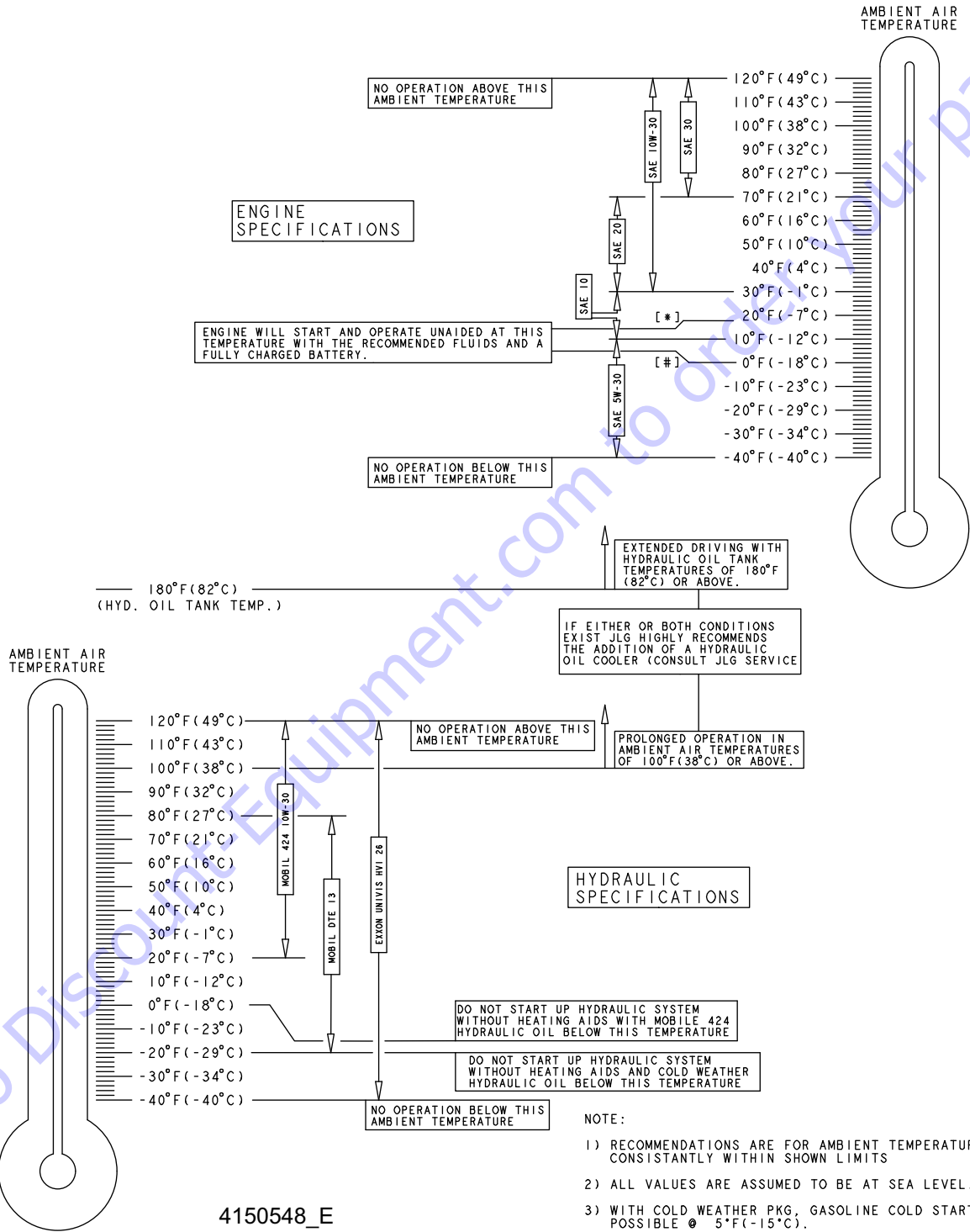

Figure 1-3. Operating Temperature Specifications - Kubota

Values for Magni Coating Fasteners (Ref 4150701)															
SAE GRADE 5 BOLTS & GRADE 2 NUTS					SAE GRADE 8 (HEX HD) BOLTS & GRADE 8 NUTS*										
Size	TPI	Bolt Dia	Tensile Stress Area	Clamp Load	Torque (Dry) K=0.17	Torque (Locitie® 242™ or 271™ OR Vibra-TITE™ K=0.16)		Torque (Locitie® 262™ or VIBRA-TITE™ 131) K=0.15	Clamp Load	Torque (Dry or Locitie® 263) K=0.17		Torque (Locitie® 242™ or 271™ OR Vibra-TITE™ K=0.16)		Torque (Locitie® 262™ or VIBRA-TITE™ 131) K=0.15	
						IN-LB	FT-LB			IN-LB	FT-LB	IN-LB	FT-LB	IN-LB	FT-LB
4	40	0.1120	0.00604	380	7	0.8									
	48	0.1120	0.00661	420	8	0.9									
6	32	0.1380	0.00909	580	14	1.5									
	40	0.1380	0.01015	610	14	1.6									
8	32	0.1640	0.01400	900	25	2.8									
	36	0.1640	0.01474	940	26	2.9									
10	24	0.1900	0.01750	1120	36	4.1									
	32	0.1900	0.02000	1285	42	4.7									
1/4	20	0.2500	0.0318	2020	86	9.7	80	9							
	28	0.2500	0.0364	2320	99	11.1	95	11							
		In	Sq In	LB	FT-LB	[N.m]	IN-LB	FT-LB	[N.m]	IN-LB	FT-LB	[N.m]	IN-LB	FT-LB	[N.m]
5/16	18	0.3125	0.0524	3340	15	20	14	19	15	20	25	20	25	20	25
	24	0.3125	0.0560	3700	15	20	15	21	15	20	25	20	25	20	25
3/8	16	0.3750	0.0775	4940	25	35	25	34	25	34	45	35	50	35	50
	24	0.3750	0.0878	5600	30	40	28	38	25	34	45	40	55	35	50
7/16	14	0.4375	0.1063	6900	40	55	40	54	35	48	60	55	75	50	70
	20	0.4375	0.1187	7550	45	60	44	60	40	54	65	60	80	60	80
1/2	13	0.5000	0.1419	9050	65	90	60	82	55	75	120	85	115	80	110
	20	0.5000	0.1589	10700	75	100	71	97	65	88	140	100	135	90	120
9/16	12	0.5625	0.1820	11600	90	120	87	118	80	109	160	115	150	115	155
	18	0.5625	0.2030	12950	105	145	97	132	90	122	185	135	185	130	175
5/8	11	0.6250	0.2260	14400	130	175	120	163	115	156	205	170	230	160	220
	18	0.6250	0.2560	16300	145	195	136	185	125	170	230	205	280	180	245
3/4	10	0.7500	0.3340	21300	225	305	213	290	200	272	300	320	435	300	410
	16	0.7500	0.3730	23800	255	345	238	324	225	306	335	355	465	315	430
7/8	9	0.8750	0.4620	29400	365	495	343	466	320	435	415	485	660	455	620
	14	0.8750	0.5090	32400	400	545	378	514	355	483	450	530	730	500	680
1	8	1.0000	0.6060	38600	545	740	515	700	480	653	515	695	930	645	875
	12	1.0000	0.6630	42200	600	815	563	765	530	721	590	845	1150	745	1015
1 1/8	7	1.1250	0.7630	42300	675	920	635	863	595	809	680	965	1400	965	1310
	12	1.1250	0.8560	47500	755	1025	713	969	670	911	770	1085	1570	1085	1475
1 1/4	7	1.2500	0.9690	53800	955	1300	897	1219	840	1142	870	1225	1850	1385	1855
	12	1.2500	1.0730	59600	1055	1435	993	1351	930	1265	960	1310	2100	1510	2055
1 3/8	6	1.3750	1.1550	64100	1250	1700	1175	1598	1100	1496	1040	1400	2025	1785	2430
	12	1.3750	1.3150	73000	1420	1930	1338	1820	1255	1707	1160	1615	2300	2030	2760
1 1/2	6	1.5000	1.4050	78000	1660	2260	1560	2122	1465	1992	1265	1850	2650	2370	3225
	12	1.5000	1.5800	87700	1865	2535	1754	2385	1645	2237	1420	2045	2845	2665	3625

NOTES: 1. THESE TORQUE VALUES DO NOT APPLY TO CADMIUM PLATED FASTENERS
 2. ALL TORQUE VALUES ARE STATIC TORQUE MEASURED PER STANDARD AUDIT METHODS TOLERANCE = ±10%
 3. * ASSEMBLY USES HARDENED WASHER

NO. 5000059 REV. K

Figure 1-5. Torque Chart (SAE Fasteners - Sheet 2 of 5)

SOCKET HEAD CAP SCREWS														
Magni Coating (Ref 4150701)*						Zinc Yellow Chromate Fasteners (Ref 4150707)*								
Size	TPI	Bolt Dia	Tensile Stress Area	Clamp Load See Note 4	Torque (Dry) K = .17	Torque (Loctite® 242™ or 271™ OR Vibra-TITE™ 111 or 140 OR Precoat 85®) K=0.16		Torque (Loctite® 262™ or TITE™ 131) K=0.15		Clamp Load See Note 4	Torque (Dry) K = .20	Torque (Loctite® 242™ or 271™ OR Vibra-TITE™ 111 or 140 OR Precoat 85®) K=0.18		Torque (Loctite® 262™ or TITE™ 131) K=0.15
						IN-LB [N.m]	FT-LB [N.m]	IN-LB [N.m]	FT-LB [N.m]			IN-LB [N.m]	FT-LB [N.m]	
4	40	0.1120	0.00604											
	48	0.1120	0.00661											
6	32	0.1380	0.00909											
	40	0.1380	0.01015											
8	32	0.1640	0.01400											
	36	0.1640	0.01474											
10	24	0.1900	0.01750											
	32	0.1900	0.02000											
1/4	20	0.2500	0.0318	2860	122	14	114	13		2860	143	16	129	
	28	0.2500	0.0364	3280	139	16	131	15		3280	164	19	148	17
5/16	18	0.3125	0.0524	4720	20	25	20	25		4720	25	35	20	25
	24	0.3125	0.0580	5220	25	35	20	25		5220	35	25	25	25
3/8	16	0.3750	0.0775	7000	35	50	35	50		7000	45	60	40	55
	24	0.3750	0.0878	7900	40	55	40	55		7900	50	70	45	60
7/16	14	0.4375	0.1063	9550	60	80	55	75		9550	70	95	65	90
	20	0.4375	0.1187	10700	65	90	60	80		10700	80	110	70	95
1/2	13	0.5000	0.1419	12750	90	120	85	115		12750	105	145	95	130
	20	0.5000	0.1589	14400	100	135	95	130		14400	120	165	110	150
9/16	12	0.5625	0.1820	16400	130	175	125	170		16400	155	210	140	190
	18	0.5625	0.2030	18250	145	195	135	185		18250	170	230	155	210
5/8	11	0.6250	0.2260	20350	180	245	170	230		20350	210	285	190	260
	18	0.6250	0.2560	23000	205	280	190	260		23000	240	325	215	290
3/4	10	0.7500	0.3340	30100	320	435	300	400		30100	375	510	340	460
	16	0.7500	0.3730	33600	355	485	335	455		33600	420	570	380	515
7/8	9	0.8750	0.4620	41800	515	705	485	660		41800	605	825	545	740
	14	0.8750	0.5090	45800	570	775	535	730		45800	670	910	600	815
1	8	1.0000	0.6060	51500	730	995	695	950		51500	860	1170	775	1055
	12	1.0000	0.6630	59700	845	1150	795	1080		59700	995	1355	895	1215
1 1/8	7	1.1250	0.7630	68700	1095	1490	1030	1400		68700	1290	1755	1160	1580
	12	1.1250	0.8560	77000	1225	1665	1155	1570		77000	1445	1965	1300	1770
1 1/4	7	1.2500	0.9690	87200	1545	2100	1455	1980		87200	1815	2470	1635	2225
	12	1.2500	1.0730	96600	1710	2325	1610	2190		96600	2015	2740	1810	2460
1 3/8	6	1.3750	1.1550	104000	2025	2755	1905	2590		104000	2385	3245	2145	2915
	12	1.3750	1.3150	118100	2500	3130	2165	2945		118100	2705	3680	2435	3310
1 1/2	6	1.5000	1.4050	126500	2690	3660	2530	3440		126500	3165	4305	2845	3870
	12	1.5000	1.5800	142200	3020	4105	2845	3870		142200	3555	4835	3200	4350

NO. 500059 REV. K

NOTES: 1. THESE TORQUE VALUES DO NOT APPLY TO CADMIUM PLATED FASTENERS

2. ALL TORQUE VALUES ARE STATIC TORQUE MEASURED PER STANDARD AUDIT METHODS TOLERANCE = ±10%

*3. ASSEMBLY USES HARDENED WASHER OR FASTENER IS PLACED AGAINST PLATED STEEL OR RAW ALUMINUM

4. CLAMP LOAD LISTED FOR SHCS IS SAME AS GRADE 8 OR CLASS 10.9 AND DOES NOT REPRESENT FULL STRENGTH CAPABILITY OF SHCS. IF HIGHER LOAD IS REQUIRED, ADDITIONAL TESTING IS REQUIRED.

Figure 1-6. Torque Chart (SAE Fasteners - Sheet 3 of 5)

Values for Zinc Yellow Chromate Fasteners (Ref 4150707)											
CLASS 10.9 METRIC (HEX HEAD) BOLTS CLASS 10 METRIC NUTS CLASS 12.9 SOCKET HEAD CAP SCREWS M3 - M5*											
CLASS 8.8 METRIC (HEX/SOCKET HEAD) BOLTS CLASS 8 METRIC NUTS											
Size	PITCH	Tensile Stress Area	Clamp Load	Torque (Dry or Locilite® 263™)	Torque (Lub)	Torque (Locilite® 262™ OR Vibra-TITE™ 131)	Torque (Locilite® 242™ or 271™ OR Vibra-TITE™ 111 or 140)	Clamp Load	Torque (Dry or Locilite® 263™) K=0.20	Torque (Lub OR Locilite® 242™ or 271™ OR Vibra-TITE™ 111 or 140) K=0.18	Torque (Locilite® 262™ OR Vibra-TITE™ 131) K=0.15
		Sq mm	KN	[N.m]	[N.m]	[N.m]	[N.m]	KN	[N.m]	[N.m]	[N.m]
3	0.5	5.03	2.19	1.3	1.0	1.2	1.4	3.13			
3.5	0.6	6.78	2.95	2.1	1.6	1.9	2.3	4.22			
4	0.7	8.78	3.82	3.1	2.3	2.8	3.4	5.47			
5	0.8	14.20	6.18	6.2	4.6	5.6	6.8	8.85			
6	1	20.10	8.74	11	7.9	9.4	12	12.5			
7	1	28.90	12.6	18	13	16	19	18.0	25	23	19
8	1.25	36.60	15.9	26	19	23	28	22.8	37	33	27
10	1.5	58.00	25.2	50	38	45	55	36.1	70	65	55
12	1.75	84.30	36.7	88	66	79	97	52.5	125	115	95
14	2	115	50.0	140	105	126	154	71.6	200	180	150
16	2	157	68.3	219	164	197	241	97.8	315	280	235
18	2.5	192	83.5	301	226	271	331	119.5	430	385	325
20	2.5	245	106.5	426	320	383	469	152.5	610	550	460
22	2.5	303	132.0	581	436	523	639	189.0	830	750	625
24	3	353	153.5	737	553	663	811	222.0	1065	960	800
27	3	459	199.5	1080	810	970	1130	286.0	1545	1390	1160
30	3.5	561	244.0	1460	1100	1320	1530	349.5	2095	1885	1575
33	3.5	694	302.0	1990	1490	1790	2090	432.5	2855	2570	2140
36	4	817	355.0	2560	1920	2300	2690	509.0	3665	3300	2750
42	4.5	1120	487.0	4090	3070	3680	4290	698.0	5865	5275	4395

NO. 500059 REV. K

NOTES: 1. THESE TORQUE VALUES DO NOT APPLY TO CADMIUM PLATED FASTENERS
 2. ALL TORQUE VALUES ARE STATIC TORQUE MEASURED PER STANDARD AUDIT METHODS TOLERANCE = ±10%
 *3. ASSEMBLY USES HARDENED WASHER OR FASTENER IS PLACED AGAINST PLATED STEEL OR RAW ALUMINIUM
 4. CLAMP LOAD LISTED FOR SHCS IS SAME AS GRADE 8 OR CLASS 10.9 AND DOES NOT REPRESENT FULL STRENGTH CAPABILITY OF SHCS. IF HIGHER LOAD IS REQUIRED, ADDITIONAL TESTING IS REQUIRED.

Figure 1-7. Torque Chart (Metric Fasteners - Sheet 4 of 5)

Values for Magni Coated Fasteners (Ref 4150701)										
CLASS 8.8 METRIC (HEX/ SOCKET HEAD) BOLTS CLASS 8 METRIC NUTS					CLASS 10.9 METRIC (HEX HEAD) BOLTS CLASS 10 METRIC NUTS CLASS 12.9 SOCKET HEAD CAP SCREWS M6 AND ABOVE*					
Size	PITCH	Tensile Stress Area	Clamp Load	Torque (Dry or Loclote® 263™) K=0.17	Torque (Loclote® 262™ OR Vibra-TITE™ 131) K=0.16	Torque (Loclote® 242™ or 271™ OR Vibra-TITE™ 111 or 140) K=0.15	Clamp Load	Torque (Dry or Loclote® 263™) K = 0.17	Torque (Lub OR Loclote® 242™ or 271™ OR Vibra-TITE™ 111 or 140) K= 0.16	Torque (Loclote® 262™ OR Vibra-TITE™ 131) K=0.15
		Sq mm	KN	[N.m]	[N.m]	[N.m]	KN	[N.m]	[N.m]	[N.m]
3	0.5	5.03	2.19	1.1	1.1	1.0	3.13			
3.5	0.6	6.78	2.95	1.8	1.7	1.5	4.22			
4	0.7	8.78	3.82	2.6	2.4	2.3	5.47			
5	0.8	14.20	6.18	5.3	4.9	4.6	8.85			
6	1	20.10	8.74	9	8.4	7.9	12.5	13	12	11
7	1	28.90	12.6	15	14	13	18.0	21	20	19
8	1.25	36.60	15.9	22	20	19	22.8	31	29	27
10	1.5	58.00	25.2	43	40	38	36.1	61	58	55
12	1.75	84.30	36.7	75	70	66	52.5	105	100	95
14	2	115	50.0	119	110	105	71.6	170	160	150
16	2	157	68.3	186	175	165	97.8	265	250	235
18	2.5	192	83.5	256	240	225	119.5	365	345	325
20	2.5	245	106.5	362	340	320	152.5	520	490	460
22	2.5	303	132.0	494	465	435	189.0	705	665	625
24	3	353	153.5	627	590	555	222.0	905	850	800
27	3	459	199.5	916	860	810	286.0	1315	1235	1160
30	3.5	561	244.0	1245	1170	1100	349.5	1780	1680	1575
33	3.5	694	302.0	1694	1595	1495	432.5	2425	2285	2140
36	4	817	355.5	2176	2050	1920	509.0	3115	2930	2750
42	4.5	1120	487.0	3477	3275	3070	698.0	4985	4690	4395

NO. 500059 REV. K

NOTES: 1. THESE TORQUE VALUES DO NOT APPLY TO CADMIUM PLATED FASTENERS

2. ALL TORQUE VALUES ARE STATIC TORQUE MEASURED PER STANDARD AUDIT METHODS TOLERANCE = ±10%

*3. ASSEMBLY USES HARDENED WASHER OR FASTENER IS PLACED AGAINST PLATED STEEL OR RAW ALUMINUM

4. CLAMP LOAD LISTED FOR SHCS IS SAME AS GRADE 8 OR CLASS 10.9 AND DOES NOT REPRESENT FULL STRENGTH CAPABILITY OF SHCS. IF HIGHER LOAD IS REQUIRED, ADDITIONAL TESTING IS REQUIRED.

Figure 1-8. Torque Chart (Metric Fasteners - Sheet 5 of 5)

PARTS FINDER

**Search Website
by Part Number**



**Search Manual
Library For Parts
Manual & Lookup Part
Numbers – Purchase
or Request Quote**

Search Manuals

Enter your information to search for manuals and parts.

* Brand:

* Model:

* Serial:

* Part Number:

SEARCH

**Can't Find Part or
Manual? Request Help
by Manufacturer,
Model & Description**

Parts Order Form

Please fill in the following information:

Manufacturer:

Model:

Description:

Quantity:

Part Number:

Part Name:

Part Description:

Part Location:

Part Condition:

Part Status:

Part Date:

Part Price:

Part Location:

Part Condition:

Part Status:

Part Date:

Part Price:

Part Location:

Part Condition:

Part Status:

Part Date:

Part Price:

Discount-Equipment.com is your online resource for quality parts & equipment.

Florida: **561-964-4949** Outside Florida TOLL FREE: **877-690-3101**

Need parts?

Click on this link: <http://www.discount-equipment.com/category/5443-parts/> and choose one of the options to help get the right parts and equipment you are looking for. Please have the machine model and serial number available in order to help us get you the correct parts. If you don't find the part on the website or on one of the online manuals, please fill out the request form and one of our experienced staff members will get back to you with a quote for the right part that your machine needs.

We sell worldwide for the brands: Genie, Terex, JLG, MultiQuip, Mikasa, Essick, Whiteman, Mayco, Toro Stone, Diamond Products, Generac Magnum, Airman, Haulotte, Barreto, Power Blanket, Nifty Lift, Atlas Copco, Chicago Pneumatic, Allmand, Miller Curber, Skyjack, Lull, Skytrak, Tsurumi, Husquvarna Target, , Stow, Wacker, Sakai, Mi-T- M, Sullair, Basic, Dynapac, MBW, Weber, Bartell, Bennar Newman, Haulotte, Ditch Runner, Menegotti, Morrison, Contec, Buddy, Crown, Edco, Wyco, Bomag, Laymor, Barreto, EZ Trench, Bil-Jax, F.S. Curtis, Gehl Pavers, Heli, Honda, ICS/PowerGrit, IHI, Partner, Imer, Clipper, MMD, Koshin, Rice, CH&E, General Equipment, ,AMida, Coleman, NAC, Gradall, Square Shooter, Kent, Stanley, Tamco, Toku, Hatz, Kohler, Robin, Wisconsin, Northrock, Oztec, Toker TK, Rol-Air, Small Line, Wanco, Yanmar

SECTION 2. PROCEDURES

2.1 GENERAL

This section provides information necessary to perform maintenance on the scissor lift. Descriptions, techniques and specific procedures are designed to provide the safest and most efficient maintenance for use by personnel responsible for ensuring the correct installation and operation of machine components and systems. With proper care, maintenance and inspections performed per JLG's recommendations with any and all discrepancies corrected, this product will be fit for continued use.

⚠ CAUTION

WHEN AN ABNORMAL CONDITION IS NOTED AND PROCEDURES CONTAINED HEREIN DO NOT SPECIFICALLY RELATE TO THE NOTED IRREGULARITY, WORK SHOULD BE STOPPED AND TECHNICALLY QUALIFIED GUIDANCE OBTAINED BEFORE WORK IS RESUMED.

The maintenance procedures included consist of servicing and component removal and installation, disassembly and assembly, inspection, lubrication and cleaning. Information on any special tools or test equipment is also provided where applicable.

2.2 SERVICING AND MAINTENANCE GUIDELINES

General

The following information is provided to assist you in the use and application of servicing and maintenance procedures contained in this chapter.

Safety and Workmanship

Your safety, and that of others, is the first consideration when engaging in the maintenance of equipment. Always be conscious of weight. Never attempt to move heavy parts without the aid of a mechanical device. Do not allow heavy objects to rest in an unstable position. When raising a portion of the equipment, ensure that adequate support is provided.

Cleanliness

1. The most important single item in preserving the long service life of a machine is to keep dirt and foreign materials out of the vital components. Precautions have been taken to safeguard against this. Shields, covers, seals, and filters are provided to keep air, fuel, and oil supplies clean; however, these items must be maintained on a scheduled basis in order to function properly.
2. At any time when air, fuel, or oil lines are disconnected, clear adjacent areas as well as the openings and fittings themselves. As soon as a line or component is disconnected, cap or cover all openings to prevent entry of foreign matter.

3. Clean and inspect all parts during servicing or maintenance, and assure that all passages and openings are unobstructed. Cover all parts to keep them clean. Be sure all parts are clean before they are installed. New parts should remain in their containers until they are ready to be used.

Components Removal and Installation

1. Use adjustable lifting devices, whenever possible, if mechanical assistance is required. All slings (chains, cables, etc.) should be parallel to each other and as near perpendicular as possible to top of part being lifted.
2. Should it be necessary to remove a component on an angle, keep in mind that the capacity of an eyebolt or similar bracket lessens, as the angle between the supporting structure and the component becomes less than 90°.
3. If a part resists removal, check to see whether all nuts, bolts, cables, brackets, wiring, etc., have been removed and that no adjacent parts are interfering.

Component Disassembly and Reassembly

When disassembling or reassembling a component, complete the procedural steps in sequence. Do not partially disassemble or assemble one part, then start on another. Always recheck your work to assure that nothing has been overlooked. Do not make any adjustments, other than those recommended, without obtaining proper approval.

Pressure-Fit Parts

When assembling pressure-fit parts, use an "anti-seize" or molybdenum disulfide base compound to lubricate the mating surface.

Bearings

1. When a bearing is removed, cover it to keep out dirt and abrasives. Clean bearings in nonflammable cleaning solvent and allow to drip dry. Compressed air can be used but do not spin the bearing.
2. Discard bearings if the races and balls (or rollers) are pitted, scored, or burned.
3. If a bearing is found to be serviceable, apply a light coat of oil and wrap it in clean (waxed) paper. Do not unwrap reusable or new bearings until they are ready to install.
4. Lubricate new or used serviceable bearings before installation. When pressing a bearing into a retainer or bore, apply pressure to the outer race. If the bearing is to be installed on a shaft, apply pressure to the inner race.

Gaskets

Check that holes in gaskets align with openings in the mating parts. If it becomes necessary to hand-fabricate a gasket, use gasket material or stock of equivalent material and thickness. Be sure to cut holes in the right location, as blank gaskets can cause serious system damage.

Bolt Usage and Torque Application

1. Use bolts of proper length. A bolt which is too long will bottom before the head is tight against its related part. If a bolt is too short, there will not be enough thread area to engage and hold the part properly. When replacing bolts, use only those having the same specifications of the original, or one which is equivalent.
2. Unless specific torque requirements are given within the text, standard torque values should be used on heat-treated bolts, studs, and steel nuts, in accordance with recommended shop practices.

Hydraulic Lines and Electrical Wiring

Clearly mark or tag hydraulic lines and electrical wiring, as well as their receptacles, when disconnecting or removing them from the unit. This will assure that they are correctly reinstalled.

Hydraulic System

1. Keep the system clean. If evidence of metal or rubber particles is found in the hydraulic system, drain and flush the entire system.
2. Disassemble and reassemble parts on clean work surface. Clean all metal parts with non-flammable cleaning solvent. Lubricate components, as required, to aid assembly.

Lubrication

Service applicable components with the amount, type, and grade of lubricant recommended in this manual, at the specified intervals. When recommended lubricants are not available, consult your local supplier for an equivalent that meets or exceeds the specifications listed.

Batteries

Clean batteries, using a non-metallic brush and a solution of baking soda and water. Rinse with clean water. After cleaning, thoroughly dry batteries and coat terminals with an anti-corrosion compound.

Lubrication and Servicing

Components and assemblies requiring lubrication and servicing are shown in Section 1.

2.3 LUBRICATION INFORMATION

Hydraulic System

1. The primary enemy of a hydraulic system is contamination. Contaminants enter the system by various means, e.g., using inadequate hydraulic oil, allowing moisture, grease, filings, sealing components, sand, etc., to enter when performing maintenance, or by permitting the pump to cavitate due to insufficient system warm-up or leaks in the pump supply (suction) lines.
2. The design and manufacturing tolerances of the component working parts are very close, therefore, even the smallest amount of dirt or foreign matter entering a system can cause wear or damage to the components and generally results in faulty operation. Every precaution must be taken to keep hydraulic oil clean, including reserve oil in storage. Hydraulic system filters should be checked, cleaned, and/or replaced as necessary, at the specified intervals required in the Lubrication Chart in Section 1 and the Preventive Maintenance and Inspection Chart in this section. Always examine filters for evidence of metal particles.
3. Cloudy oils indicate a high moisture content which permits organic growth, resulting in oxidation or corrosion. If this condition occurs, the system must be drained, flushed, and refilled with clean oil.
4. It is not advisable to mix oils of different brands or types, except as recommended, as they may not contain the same required additives or be of comparable viscosities. Good grade mineral oils, with viscosities suited to the ambient temperatures in which the machine is operating, are recommended for use.

NOTE: *Metal particles may appear in the oil or filters of new machines due to the wear-in of meshing components.*

Hydraulic Oil

1. Refer to Section 1 for recommendations for viscosity ranges.
2. JLG recommends Mobilfluid 424, which has an SAE viscosity of 10W-30 and a viscosity index of 152.

NOTE: *Start-up of hydraulic system with oil temperatures below -15°F (-26°C) is not recommended. If it is necessary to start the system in a sub-zero environment, it will be necessary to heat the oil with a low density, 100VAC heater to a minimum temperature of -15°F (-26°C).*

3. The only exception to the above is to drain and fill the system with Mobil DTE 11 oil or its equivalent. This will allow start up at temperatures down to -20°F (-29°C). However, use of this oil will give poor performance at temperatures above 120°F (49°C). Systems using DTE 11 oil should not be operated at temperatures above 200°F (94°C) under any condition.

Changing Hydraulic Oil

1. Use of any of the recommended crankcase or hydraulic oils eliminates the need for changing the oil on a regular basis. However, filter elements must be changed after the first 50 hours of operation and every 300 hours thereafter. If it is necessary to change the oil, use only those oils meeting or exceeding the specifications appearing in this manual. If unable to obtain the same type of oil supplied with the machine, consult local supplier for assistance in selecting the proper equivalent. Avoid mixing petroleum and synthetic base oils. JLG Industries recommends changing the hydraulic oil every two years.
2. Use every precaution to keep the hydraulic oil clean. If the oil must be poured from the original container into another, be sure to clean all possible contaminants from the service container. Always clean the mesh element of the filter and replace the cartridge any time the system oil is changed.
3. While the unit is shut down, a good preventive maintenance measure is to make a thorough inspection of all hydraulic components, lines, fittings, etc., as well as a functional check of each system, before placing the machine back in service.

Lubrication Specifications

Specified lubricants, as recommended by the component manufacturers, are always the best choice, however, multi-purpose greases usually have the qualities which meet a variety of single purpose grease requirements. Should any question arise regarding the use of greases in maintenance stock, consult your local supplier for evaluation.

2.4 CYLINDERS - THEORY OF OPERATION

Cylinders are of the double acting type. The Lift and Steer systems incorporate double acting cylinders. A double acting cylinder is one that requires oil flow to operate the cylinder rod in both directions. Directing oil (by actuating the corresponding control valve to the piston side of the cylinder) forces the piston to travel toward the rod end of the barrel, extending the cylinder rod (piston attached to rod). When the oil flow is stopped, movement of the rod will stop. By directing oil to the rod side of the cylinder, the piston will be forced in the opposite direction and the cylinder rod will retract.

A holding valve is used in the Lift circuit to prevent retraction of the cylinder rod should a hydraulic line rupture or a leak develop between the cylinder and its related control valve.

2.5 VALVES - THEORY OF OPERATION

Solenoid Control Valves (Bang-Bang)

Control valves used are four-way three-position solenoid valves of the sliding spool design. When a circuit is activated and the control valve solenoid energizes, the spool is shifted and the corresponding work port opens to permit oil flow to the component in the selected circuit, with the opposite work port opening to reservoir. Once the circuit is deactivated (control returned to neutral), the valve spool returns to neutral (center) and oil flow is then directed through the valve body and returns to reservoir. A typical control valve consists of the valve body, sliding spool, and two solenoid assemblies. The spool is machine fitted in the bore of the valve body. Lands on the spool divide the bore into various chambers, which, when the spool is shifted, align with corresponding ports in the valve body open to common flow. At the same time other ports would be blocked to flow. The spool is spring-loaded to center position, therefore when the control is released, the spool automatically returns to neutral, prohibiting any flow through the circuit.

Proportional Control Valves

The proportional control valves provide a power output matching that required by the load. A small line connected to a load sensing port feeds load pressure back to a sequence valve. The sequence valve senses the difference between the load and pump outlet pressure, and varies the pump displacement to keep the difference constant. This differential pressure is applied across the valve's meter-in spool, with the effect that pump flow is determined by the degree of spool opening, independent of load pressure. Return lines are connected together, simplifying routing of return flow and to help reduce cavitation. Load sensing lines connect through shuttle valves to feed the highest load signal back to the sequence valve. Integral actuator port relief valves, anti-cavitation check valves, and load check valves are standard.

Relief Valves

Main relief valves are installed at various points within the hydraulic system to protect associated systems and components against excessive pressure. Excessive pressure can be developed when a cylinder reaches its limit of travel and the flow of pressurized fluid continues from the system control. The relief valve provides an alternate path for the continuing flow from the pump, thus preventing rupture of the cylinder, hydraulic line or fitting. Complete failure of the system pump is also avoided by relieving circuit pressure. The relief valve is installed in the circuit between the pump outlet (pressure line) and the cylinder of the circuit, generally as an integral part of the system valve bank. Relief pressures are set slightly higher than the load requirement, with the valve diverting excess pump delivery back to the reservoir when operating pressure of the component is reached.

Crossover Relief Valves

Crossover relief valves are used in circuits where the actuator requires an operating pressure lower than that supplied to the system. When the circuit is activated and the required pressure at the actuator is developed, the crossover relief diverts excess pump flow to the reservoir. Individual, integral reliefs are provided for each side of the circuit.

2.6 COMPONENT FUNCTIONAL DESCRIPTION

Hydraulic Pump

The machine is equipped with two hydraulic pumps, a function pump and a drive pump. The function pump is a single-section gear pump that controls the lift and steer functions and provides a maximum output of 4.75 gpm (18 lpm). The drive pump is a single-section piston pump that controls the drive function and provides an output of 22 gpm (83.3 lpm).

Lift Cylinder Counterbalance/Manual Descent Valve

The lift cylinder counterbalance/manual descent valve is located on top of the lift cylinder. The counterbalance valve is used to hold the platform in place when raised. A cable is connected to the valve which, when pulled, manually opens the lift down port and allows the platform to be lowered in the event hydraulic power is lost.

2.7 WEAR PADS

Sliding Pads

The original thickness of the sliding pads is 2 inches (51 mm). Replace sliding pads when worn to 1.875 inches (48 mm).

2.8 CYLINDER CHECKING PROCEDURES

NOTE: Cylinder checks must be performed any time a cylinder component is replaced or when improper system operation is suspected.

Cylinder w/o Counterbalance Valves - Steer Cylinder

NOTICE

OPERATE FUNCTIONS FROM GROUND CONTROL STATION ONLY. DO NOT FULLY EXTEND CYLINDER TO END OF STROKE. RETRACT CYLINDER SLIGHTLY TO AVOID TRAPPING PRESSURE.

1. Using all applicable safety precautions, activate motor and fully extend cylinder to be checked. Shut down motor.
2. Carefully disconnect hydraulic hose from retract port of cylinder. There will be initial weeping of hydraulic fluid which can be caught in a suitable container. After the initial discharge, there should be no further leakage from the retract port.
3. Activate motor and activate cylinder extend function. Check retract port for leakage.
4. If cylinder leakage is 6-8 drops per minute or more, piston seals are defective and must be replaced. If cylinder retract port leakage is less than 6-8 drops per minute, carefully reconnect hose to retract port and retract cylinder.
5. With cylinder fully retracted, shut down motor and carefully disconnect hydraulic hose from cylinder extend port.
6. Activate motor and activate cylinder retract function. Check extend port for leakage.
7. If cylinder leakage is 6-8 drops per minute or more, piston seals are defective and must be replaced. If extend port leakage is less than 6-8 drops per minute, carefully reconnect hose to extend port, then activate cylinder through one complete cycle and check for leaks.

Cylinders w/Single Counterbalance Valves - Lift Cylinder

NOTICE

OPERATE ALL FUNCTIONS FROM GROUND CONTROL STATION ONLY.

1. Using all applicable safety precautions, activate hydraulic system.

WARNING

WHEN WORKING ON THE LIFT CYLINDER, RAISE THE PLATFORM COMPLETELY AND SUPPORT THE PLATFORM USING A SUITABLE OVERHEAD LIFTING DEVICE. DO NOT FULLY EXTEND LIFT CYLINDER TO END OF STROKE. RETRACT CYLINDER SLIGHTLY TO AVOID TRAPPING PRESSURE.

2. Raise platform completely then retract cylinder slightly to avoid trapping pressure. Place a suitable overhead lifting device approximately 1 inch (2.5 cm) below the platform.
3. Shut down hydraulic system and allow machine to sit for 10-15 minutes. Carefully remove hydraulic hoses from cylinder port block.
4. There will be initial weeping of hydraulic fluid, which can be caught in a suitable container. After the initial discharge, there should not be any further leakage from the ports. If leakage continues at a rate of 6-8 drops per minute or more, the counterbalance valve is defective and must be replaced.
5. If no repairs are necessary or when repairs have been made, carefully reconnect hydraulic hoses to the appropriate ports.
6. Remove lifting device from platform, activate hydraulic system and run cylinder through one complete cycle to check for leaks.

2.9 LIFT CYLINDER REMOVAL AND INSTALLATION.

⚠ WARNING

NEVER WORK UNDER AN ELEVATED PLATFORM UNTIL IT HAS BEEN RESTRAINED FROM MOVEMENT WITH SAFETY PROPS, BLOCKING OR OVERHEAD SLINGS.

Removal

1. Place the machine on a flat and level surface with enough overhead clearance to raise the platform. Start the motor and raise the platform enough to rotate the scissor arm safety prop into position, lower the arms onto the prop. Shut down the engine and attach a suitable overhead lifting device to the platform for added support. (See Figure 2-1.)
2. Using a suitable lifting device capable of lifting 160 lb. (73 kg), place a strap/sling around the lift cylinder barrel to support it when the upper and lower attach pins are removed in the following steps. (See Figure 2-2.)
3. Remove the bolt and lock nut securing the cylinder rod attach pin to the upper inner arm assembly. Using a suitable brass drift, drive out the rod end attach pin from the arm assembly.
4. Start the motor and retract the lift cylinder rod completely by using the ground control - platform lift down switch. Shut machine down.
5. Tag and disconnect the lift cylinder hydraulic lines, then cap the lines and ports.
6. Disconnect the manual descent cable from the side of the cylinder valve block.
7. Move the previously installed lift cylinder support strap, or add a new strap, to balance the cylinder when removing the lower attach pin.
8. Remove the bolt and lock nut securing the barrel end attach pin to the lower arm assembly. Using a suitable brass drift, drive out the barrel end attach pin from the arm assembly.
9. Using the lifting device, carefully maneuver the cylinder from the scissor lift and place in a suitable work area.

Installation

1. Install lift cylinder in place using suitable lifting straps, aligning barrel end attach pin mounting holes on lower arm assembly.
2. Using a suitable drift, drive the barrel end attach pin through the mounting holes in the lift cylinder and the lower arm assembly. Secure in place with the bolt and a new locknut.
3. Remove cylinder port plugs and hydraulic line caps and correctly attach lines to cylinder ports. Reconnect the manual descent cable to the valve block.
4. Extend the cylinder rod until the attach pin hole aligns with those in the upper arm assembly. Using a suitable drift, drive the cylinder rod attach pin through the aligned holes, taking care to align the pin retaining hole with the hole in arm assembly. Secure the pin in place with the bolt and a new locknut.
5. Lower platform to stowed position and shut down motor. Check hydraulic fluid level and adjust accordingly.

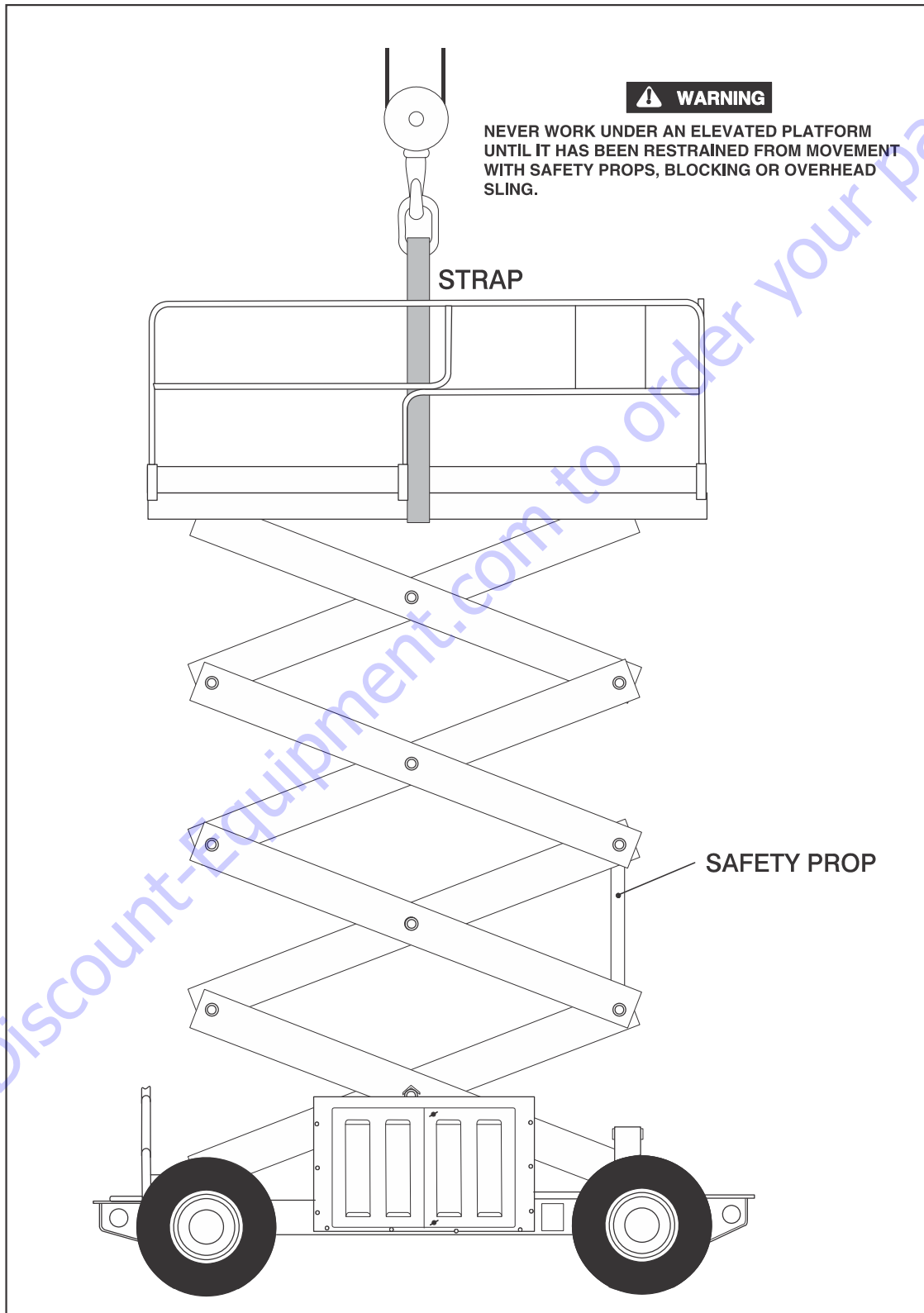
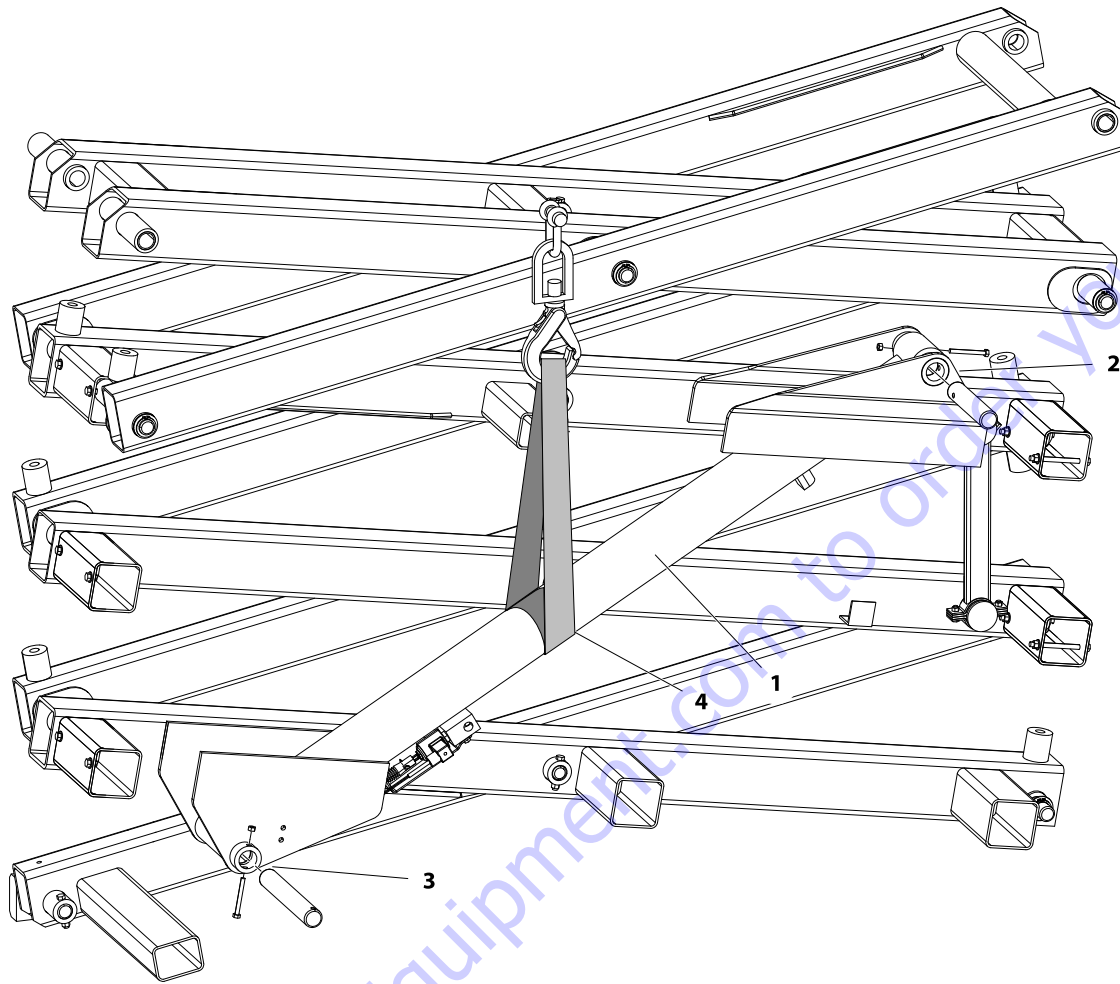
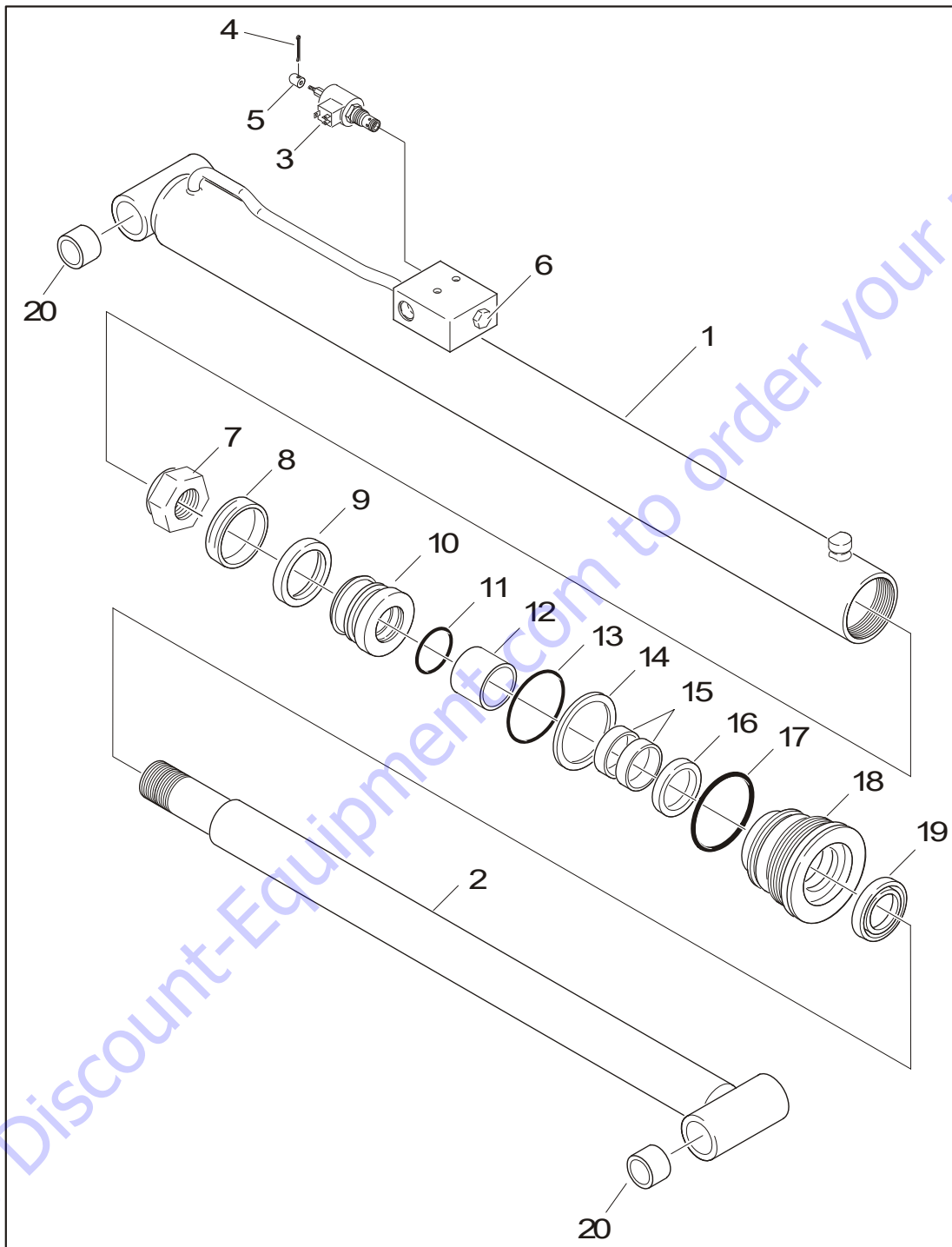

Figure 2-1. Arms and Platform Positioning and Support, Cylinder Repair



- 1. Lift Cylinder
- 2. Upper Attach Pin, Bolt and Locking Nut
- 3. Lower Attach Pin, Bolt and Locking Nut
- 4. Overhead Lifting Hook with Sling/Strap

Figure 2-2. Lift Cylinder Removal - Cylinder Support



- | | | | |
|-------------------|---------------------------|------------------|-------------|
| 1. Barrel | 6. Restrictor/Check Valve | 11. O-Ring | 16. Seal |
| 2. Rod | 7. Locknut | 12. Spacer | 17. O-Ring |
| 3. Solenoid Valve | 8. Wear Ring | 13. O-Ring | 18. Head |
| 4. Cotter Pin | 9. Seal | 14. Back-Up Ring | 19. Wiper |
| 5. Cable Adaptor | 10. Piston | 15. Wear Ring | 20. Bushing |

Figure 2-3. Lift Cylinder

2.10 CYLINDER REPAIR

Disassembly

NOTICE

DISASSEMBLY OF THE CYLINDER SHOULD BE PERFORMED ON A CLEAN WORK SURFACE IN A DIRT FREE WORK AREA.

1. Connect a suitable auxiliary hydraulic power source to the cylinder port block fitting.

NOTICE

DO NOT FULLY EXTEND CYLINDER TO END OF STROKE. RETRACT CYLINDER SLIGHTLY TO AVOID TRAPPING PRESSURE.

2. Operate the hydraulic power source and extend the cylinder. Shut down and disconnect the power source. Adequately support the cylinder rod, if necessary.
3. If applicable, remove the cartridge-type holding valve and fittings from the cylinder port block. Discard o-rings.
4. Place the cylinder barrel into a suitable holding fixture.

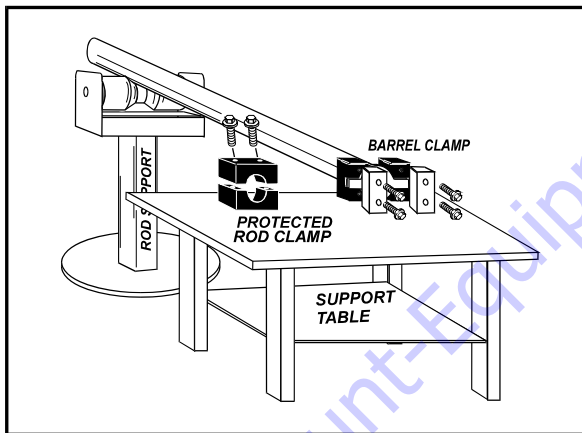

Figure 2-4. Cylinder Barrel Support

5. Mark cylinder head and barrel with a center punch for easy realignment. Using an allen wrench, loosen the cyl-

inder head retainer cap screws, and remove cap screws from cylinder barrel.

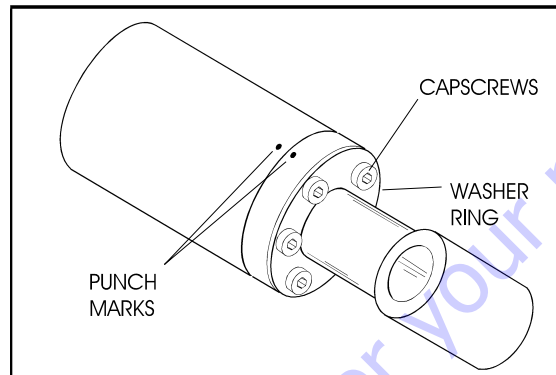

Figure 2-5. Capscrew Removal

6. Using a spanner wrench, loosen the end cap or head retainer, and remove from cylinder barrel.
7. Attach a suitable pulling device to the cylinder rod port block end or cylinder rod end, as applicable.

EXTREME CARE SHOULD BE TAKEN WHEN REMOVING THE CYLINDER ROD, HEAD, AND PISTON. AVOID PULLING THE ROD OFF-CENTER, WHICH COULD CAUSE DAMAGE TO THE PISTON AND CYLINDER BARREL SURFACES.

8. With the barrel clamped securely, apply pressure to the rod pulling device and carefully withdraw the complete rod assembly from the cylinder barrel.

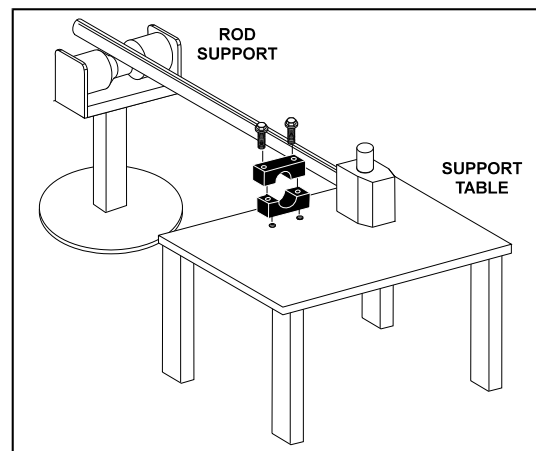

Figure 2-6. Cylinder Rod Support

9. Using suitable protection, clamp the cylinder rod in a vise or similar holding fixture as close to the piston as possible.
10. Loosen and remove the cap screw(s), if applicable, which attach the tapered bushing to the piston.

11. Insert the cap screw(s) in the threaded holes in the outer piece of the tapered bushing. Progressively tighten the cap screw(s) until the bushing is loose on the piston.
12. Remove the bushing from the piston.

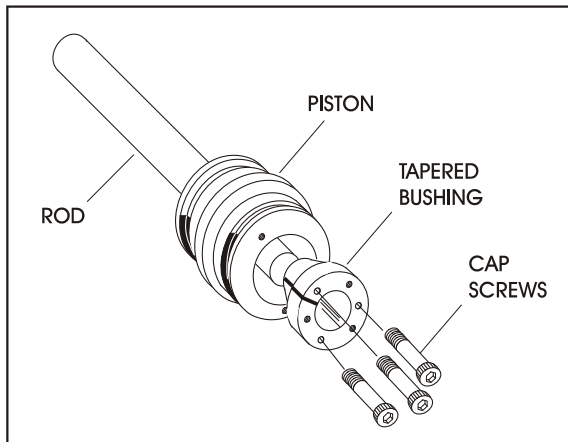

Figure 2-7. Tapered Bushing Removal

13. Screw the piston CCW, by hand, and remove the piston from cylinder rod.
14. Remove and discard the piston o-rings, seal rings, and backup rings.
15. Remove piston spacer, if applicable, from the rod.
16. Remove the rod from the holding fixture. Remove the cylinder head gland and retainer plate, if applicable. Discard the o-rings, back-up rings, rod seals, and wiper seals.

Cleaning and Inspection

1. Clean all parts thoroughly in an approved cleaning solvent.
2. Inspect the cylinder rod for scoring, tapering, ovality, or other damage. If necessary, dress rod with Scotch Brite or equivalent. Replace rod if necessary.
3. Inspect threaded portion of rod for excessive damage. Dress threads as necessary.
4. Inspect inner surface of cylinder barrel tube for scoring or other damage. Check inside diameter for tapering or ovality. Replace if necessary.
5. Inspect threaded portion of barrel for damage. Dress threads as necessary.
6. Inspect piston surface for damage and scoring and for distortion. Dress piston surface or replace piston as necessary.
7. Inspect threaded portion of piston for damage. Dress threads as necessary.

8. Inspect seal and o-ring grooves in piston for burrs and sharp edges. Dress applicable surfaces as necessary.
9. Inspect cylinder head inside diameter for scoring or other damage and for ovality and tapering. Replace as necessary.
10. Inspect threaded portion of head for damage. Dress threads as necessary.
11. Inspect seal and o-ring grooves in head for burrs and sharp edges. Dress applicable surfaces as necessary.
12. Inspect cylinder head outside diameter for scoring or other damage and ovality and tapering. Replace as necessary.
13. If applicable, inspect rod and barrel bearings for signs of correct excessive wear or damage. Replace as necessary.
 - a. Thoroughly clean hole, (steel bushing) of burrs, dirt etc. to facilitate bearing installation.
 - b. Inspect steel bushing for wear or other damage. If steel bushing is worn or damaged, rod/barrel must be replaced.
 - c. Lubricate inside of the steel bushing with WD40 prior to bearing installation.
 - d. Using an arbor of the correct size, carefully press the bearing into steel bushing.
14. Inspect travel limiting collar or spacer for burrs and sharp edges. If necessary, dress inside diameter surface with Scotch Brite or equivalent.
15. If applicable, inspect port block fittings and holding valve. Replace as necessary.
16. Inspect the oil ports for blockage or the presence of dirt or other foreign material. Repair as necessary.
17. If applicable, inspect piston rings for cracks or other damage. Replace as necessary.

Assembly

NOTE: Prior to cylinder assembly, ensure that the proper cylinder seal kit is used. See your JLG Parts Manual.

Apply a light film of hydraulic oil to all components prior to assembly.

1. A special tool is used to install a new rod seal into the applicable cylinder head gland groove.

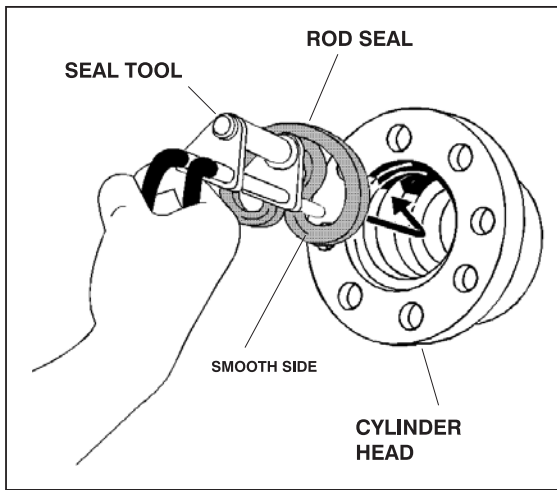

Figure 2-8. Rod Seal Installation

NOTICE

WHEN INSTALLING "POLY-PAK" PISTON SEALS, ENSURE SEALS ARE INSTALLED PROPERLY. REFER TO WIPER SEAL INSTALLATION FOR CORRECT SEAL ORIENTATION. IMPROPER SEAL INSTALLATION COULD RESULT IN CYLINDER LEAKAGE AND IMPROPER CYLINDER OPERATION.

2. Use a soft mallet to tap a new wiper seal into the applicable cylinder head gland groove. Install a new wear ring into the applicable cylinder head gland groove.

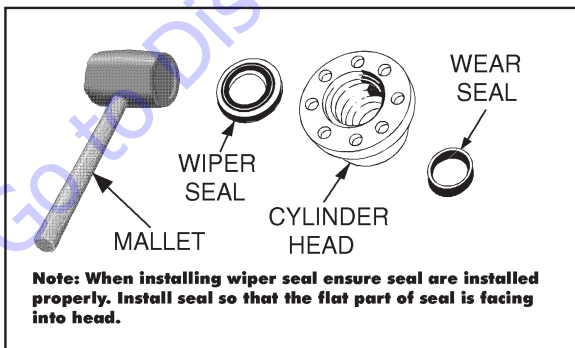

Figure 2-9. Wiper Seal Installation

3. Place a new o-ring and back-up seal in the applicable outside diameter groove of the cylinder head.

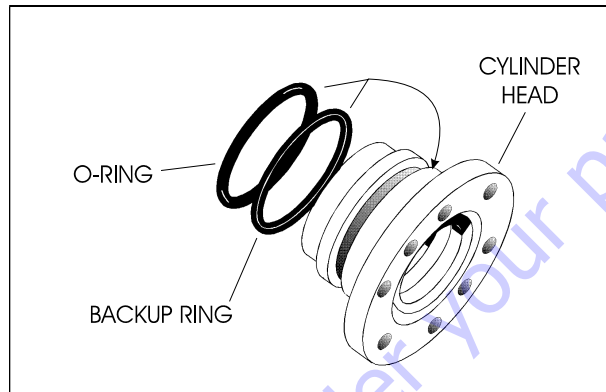

Figure 2-10. Installation of Head Seal Kit

4. Install washer ring onto rod, carefully install the head gland on the rod, ensuring that the wiper and rod seals are not damaged or dislodged. Push the head along the rod to the rod end, as applicable.
5. Carefully slide the piston spacer on the rod.
6. If applicable, correctly place new o-ring in the inner piston diameter groove. (The backup ring side facing the O-ring is grooved.)
7. If applicable, correctly place new seals and guide lock rings in the outer piston diameter groove. (A tube, with I.D. slightly larger than the O.D. of the piston is recommended to install the solid seal.)

NOTE: The backup rings for the solid seal have a radius on one side. This side faces the solid seal. (See magnified insert in Figure 2-11.) The split of seals and backup rings are to be positioned so as not to be in alignment with each other.

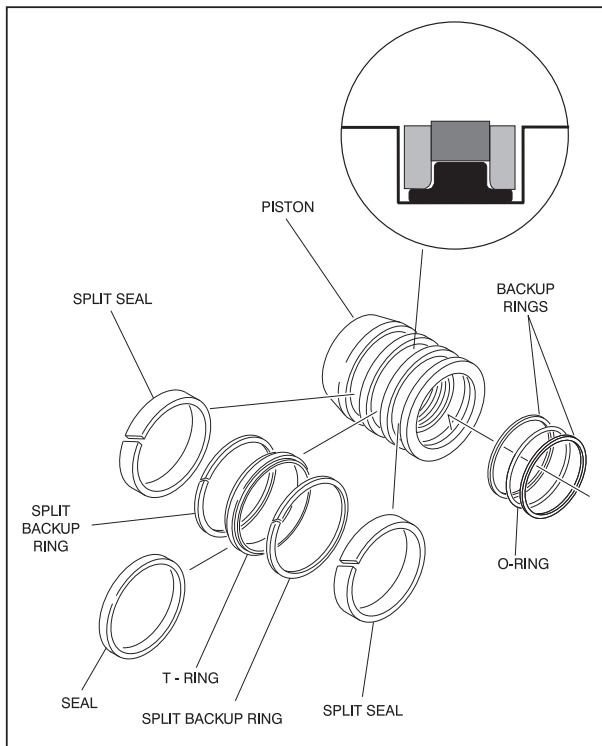

Figure 2-11. Piston Seal Kit Installation

8. Using suitable protection, clamp the cylinder rod in a vise or similar holding fixture as close to piston as possible.
9. Carefully thread the piston on the cylinder rod hand tight, ensuring that the o-ring and back-up rings are not damaged or dislodged.
10. Thread piston onto rod until it abuts the spacer end and install the tapered bushing.

NOTE: When installing the tapered bushing, piston and mating end of rod must be free of oil.

11. Assemble the tapered bushing loosely into the piston and insert JLG capscrews (not vendor capscrews) through the drilled holes in the bushing and into the tapped holes in the piston.

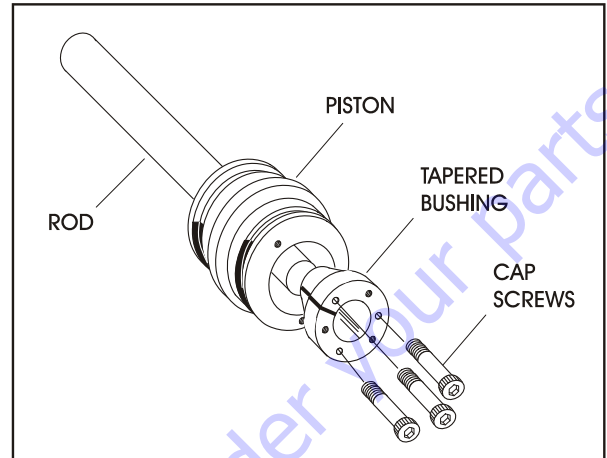

Figure 2-12. Tapered Bushing Installation

12. Tighten the capscrews evenly and progressively in rotation to the specified torque value. (See Table 2-1, Cylinder Component Torque Specifications.)
13. After the screws have been torqued, tap the tapered bushing with a hammer (16 to 24 oz.) and brass shaft (approximately 3/4" in diameter) as follows;
 - a. Place the shaft against the cylinder rod and in contact with the bushing in the spaces between the capscrews.
 - b. Tap each space once; this means the tapered bushing is tapped 3 times as there are 3 spaces between the capscrews.

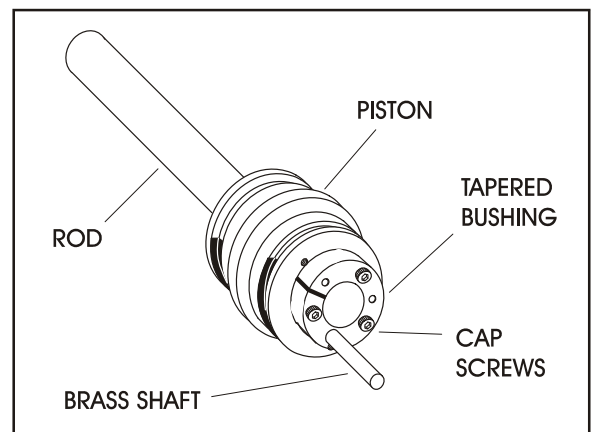

Figure 2-13. Seating the Tapered Bearing

14. Re torque the capscrews evenly and progressively in rotation to the specified torque value spec.
15. Remove the cylinder rod from the holding fixture.
16. Place new guide locks and seals in the applicable outside diameter grooves of the cylinder piston. (See Figure

2-11., Piston Seal Kit Installation)

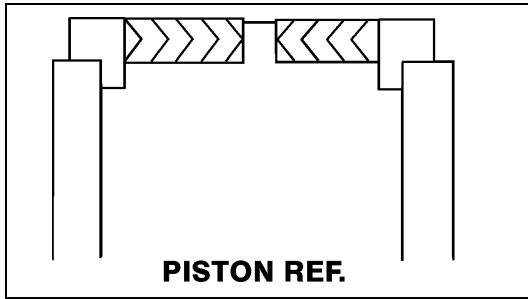

Figure 2-14. Poly-Pak Piston Seal Installation

- Position the cylinder barrel in a suitable holding fixture.

NOTICE

EXTREME CARE SHOULD BE TAKEN WHEN INSTALLING THE CYLINDER ROD, HEAD, AND PISTON. AVOID PULLING THE ROD OFF-CENTER, WHICH COULD CAUSE DAMAGE TO THE PISTON AND CYLINDER BARREL SURFACES.

- With barrel clamped securely, and while adequately supporting the rod, insert the piston end into the barrel cylinder. Ensure that the piston loading o-ring and seal ring are not damaged or dislodged.
- Continue pushing the rod into the barrel until the cylinder head gland can be inserted into the barrel cylinder.
- Secure the cylinder head gland using the washer ring and socket head bolts.

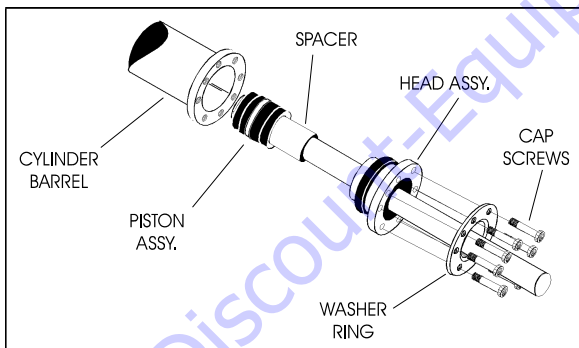

Figure 2-15. Rod Assembly Installation

- After the cylinder has been reassembled, the rod should be pushed all the way in (fully retracted) prior to the reinstallation of any holding valve or valves.

- If applicable, install the cartridge-type holding valve and fittings in the rod port block, using new o-rings as applicable. (See Table 2-1, Cylinder Component Torque Specifications).

CAUTION

IF THE CYLINDER IS TO BE TESTED PRIOR TO INSTALLATION ON THE MACHINE, EXTREME CARE SHOULD BE USED TO INSURE THAT THE OUTER END OF THE ROD IS SUPPORTED. USE EITHER A TRAVELING OVERHEAD HOIST, FORK-LIFT, OR OTHER MEANS TO SUPPORT THE OVERHANGING WEIGHT OF THE EXTENDING ROD.

- If applicable, install the cartridge-type holding valve and fittings in the port block using new o-rings as applicable. (See Table 2-2, Holding Valve Torque Specifications).

Table 2-1. Cylinder Component Torque Specifications

Component	Torque Value (w/Loctite)
Tapered Bushing Retaining Screws - Lift Cylinder	80 ft lbs (108 Nm)
Head Retaining Screws - Lift Cylinder	9 ft lbs (12 Nm)

Table 2-2. Holding Valve Torque Specifications

Description	Torque Value
Sun - 7/8 hex M20x 1.5 thds	30 - 35 ft lbs (41 - 48 Nm)
Sun - 1-1/8 hex 1 - 14 UNS thds	45 - 50 ft lbs (61 - 68 Nm)
Sun - 1-1/4 hex M36x 2 thds	150 - 153 ft lbs (204 - 207 Nm)
Racine - 1-1/8 hex 1-1/16 - 12 thds	50 - 55 ft lbs (68 - 75 Nm)
Racine - 1-3/8 hex 1-3/16 - 12 thds	75 - 80 ft lbs (102 - 109 Nm)
Racine - 1-7/8 hex 1-5/8 - 12 thds	100 - 110 ft lbs (136 - 149 Nm)

2.11 STEER CYLINDER REPAIR

Removal

Before beginning this procedure, ensure that the parking brake is engaged and the rear wheels are chocked.

1. Tag and disconnect the hydraulic lines to the steer cylinder, then cap the steer cylinder hydraulic lines and ports.
2. At each steer spindle, remove the bolt and lock nut securing the steer cylinder to the spindle.
3. When the steer cylinder is disconnected from the steer spindles, turn each wheel by hand to give clearance to remove the steer cylinder from the front axle.
4. Carefully lift the steer cylinder until the cylinder mounting block clears the mounting slot in the bottom of the axle, then slowly remove the cylinder from the axle and place it in a suitable work area.

Disassembly

NOTICE

DISASSEMBLY OF THE CYLINDER SHOULD BE PERFORMED ON A CLEAN WORK SURFACE IN A DIRT FREE WORK AREA.

1. Place the cylinder barrel into a suitable holding fixture.
2. Using a suitable chain wrench, carefully remove the cylinder head retainer from one end of the cylinder barrel.
3. Attach a suitable pulling device to one end of the cylinder rod.

NOTICE

EXTREME CARE SHOULD BE TAKEN WHEN REMOVING THE CYLINDER ROD, SPACER, AND PISTON. AVOID PULLING THE ROD OFF-CENTER, WHICH COULD CAUSE DAMAGE TO THE PISTON AND CYLINDER BARREL SURFACES.

4. With the barrel clamped securely, apply pressure to the rod pulling device and carefully withdraw the complete rod assembly from the cylinder barrel.
5. Using a suitable chain wrench, carefully remove the remaining cylinder head retainer from the opposite end of the cylinder barrel. Remove the head and remove and discard the wiper, rod seal, O-ring and wear ring.
6. Using suitable protection, clamp the cylinder rod in a vise or similar holding fixture.
7. Carefully remove the head from the cylinder rod and remove and discard the wiper, rod seal, o-ring and wear ring.
8. Carefully remove the spacers from the cylinder rod, then remove the retaining rings securing the piston in place on the cylinder rod. Discard the retaining rings.

9. Carefully remove the piston from the cylinder rod. Remove and discard the T-seal and o-ring.
10. Remove the cylinder rod from the holding fixture.

Cleaning and Inspection

1. Clean all parts thoroughly in an approved cleaning solvent.
2. Inspect the cylinder rod for scoring, tapering, ovality, or other damage. If necessary, dress the rod with Scotch Brite or equivalent. Replace the rod if necessary.
3. Inspect the threaded portion of the rod for excessive damage. Dress the threads as necessary.
4. Inspect the inner surface of the cylinder barrel tube for scoring or other damage. Check the inside diameter for tapering or ovality. Replace the barrel if necessary.
5. Inspect the piston surface for damage, scoring and distortion. Dress the piston surface or replace the piston as necessary.
6. Inspect the seal and o-ring grooves in the piston for burrs and sharp edges. Dress applicable surfaces as necessary.
7. Inspect the inside diameter of the spacers and heads for scoring or other damage and for ovality and tapering. Replace as necessary.
8. Inspect the seal and o-ring grooves in the heads for burrs and sharp edges. Dress applicable surfaces as necessary.
9. Inspect the outside diameter of the spacers and heads for scoring or other damage and ovality and tapering. Replace as necessary.
10. Inspect the oil ports for blockage or the presence of dirt or other foreign material. Repair as necessary.
11. Inspect the cam follower for wear or damage. Replace as necessary.

Assembly

NOTE: Prior to cylinder assembly, ensure that the proper cylinder seal kit is used.

Apply a light film of hydraulic oil to all components prior to assembly.

1. Using suitable protection, clamp the cylinder rod in a vise or similar holding fixture.
2. Place a new o-ring into the cylinder rod piston groove.
3. Place a new T-seal on the piston, then carefully install the piston the cylinder rod, ensuring that the o-ring in the rod groove is not damaged or dislodged. Secure the piston in place with two new retaining rings.
4. Carefully slide the spacers onto the cylinder rod.
5. Place a new wiper, rod seal, o-ring and wear ring on each of the two cylinder heads. Set the heads aside for later installation on the cylinder rod.
6. Remove the cylinder rod assembly from the holding fixture.
7. Position the cylinder barrel in a suitable holding fixture.

NOTICE

EXTREME CARE SHOULD BE TAKEN WHEN INSTALLING THE CYLINDER ROD, PISTON AND HEADS. AVOID PULLING THE ROD OFF-CENTER, WHICH COULD CAUSE DAMAGE TO THE PISTON AND CYLINDER BARREL SURFACES.

8. With the barrel clamped securely, and while adequately supporting the cylinder rod assembly, insert the cylinder rod assembly into the cylinder barrel. Ensure that the piston T-seal and o-ring are not damaged or dislodged.

9. Continue pushing the rod assembly into the cylinder barrel until the cylinder rod is approximately centered in the barrel.
10. Carefully install one of the cylinder heads on one end of the cylinder rod and push the head onto the rod until it is snug against the end of the cylinder barrel.
11. Install one of the cylinder head retainers on the end of the cylinder barrel and tighten with a suitable chain wrench.
12. Carefully install the remaining cylinder head on the opposite end of the cylinder rod and push the head onto the rod until it is snug against the end of the cylinder barrel.
13. Install the remaining cylinder head retainer on the end of the cylinder barrel and tighten with a suitable chain wrench.

Installation

1. Carefully install the steer cylinder assembly into the front axle. Align the cylinder mounting block on the barrel with the mounting slot in the bottom of the axle and lower the steer cylinder until the mounting block rests in the slot.
2. Turn the steer wheels to line up the mounting holes in the steer spindles and the steer cylinder ends. Secure each end of the steer cylinder with a bolt and lock nut.
3. Reconnect the hydraulic hoses to the applicable cylinder ports.

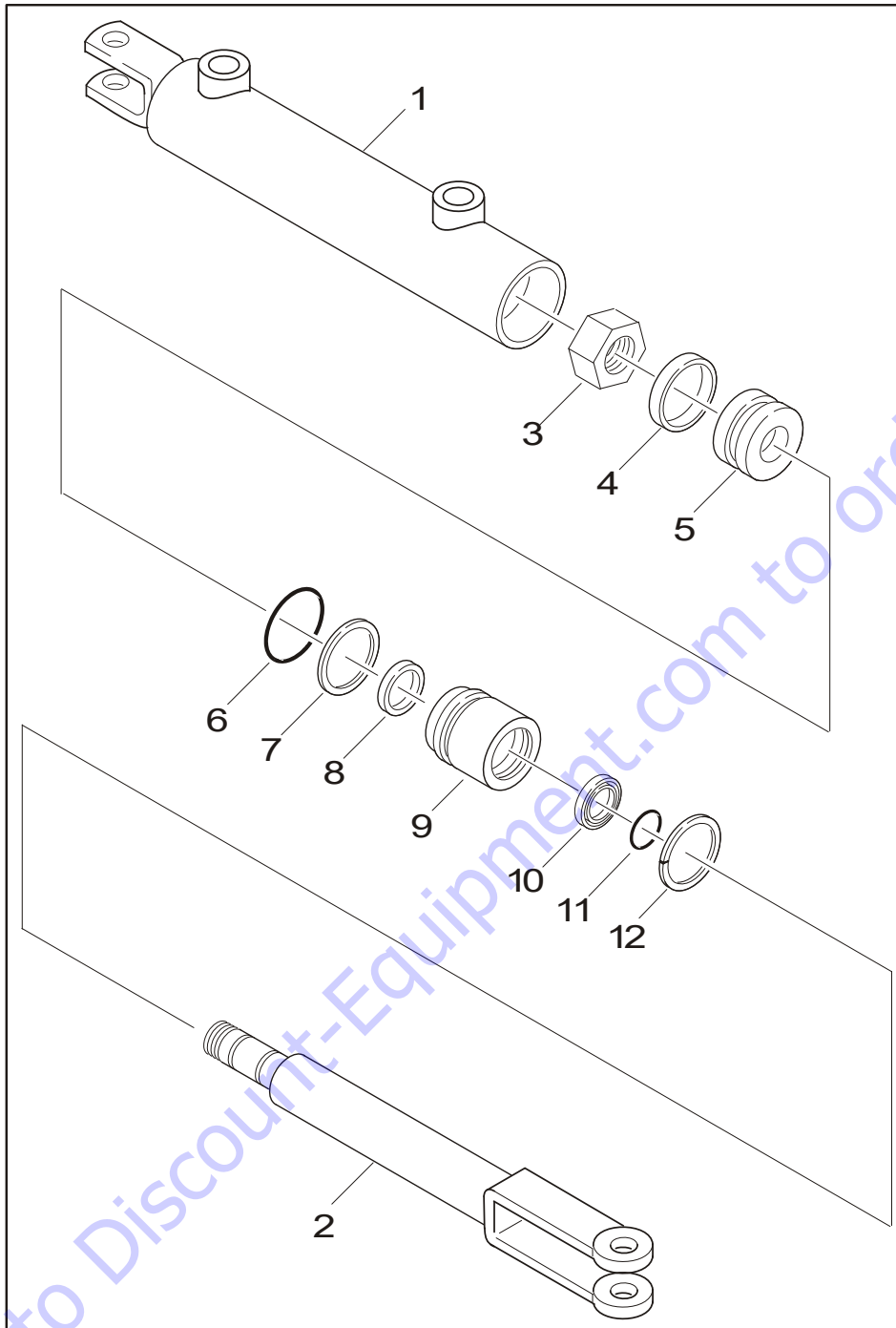

1. Barrel
2. Rod
3. Locknut
4. Seal
5. Piston
6. O-Ring
7. Back-Up Ring
8. Wear Ring
9. Guide
10. Wiper
11. O-Ring
12. Retaining Ring

Figure 2-16. Steer Cylinder Assembly

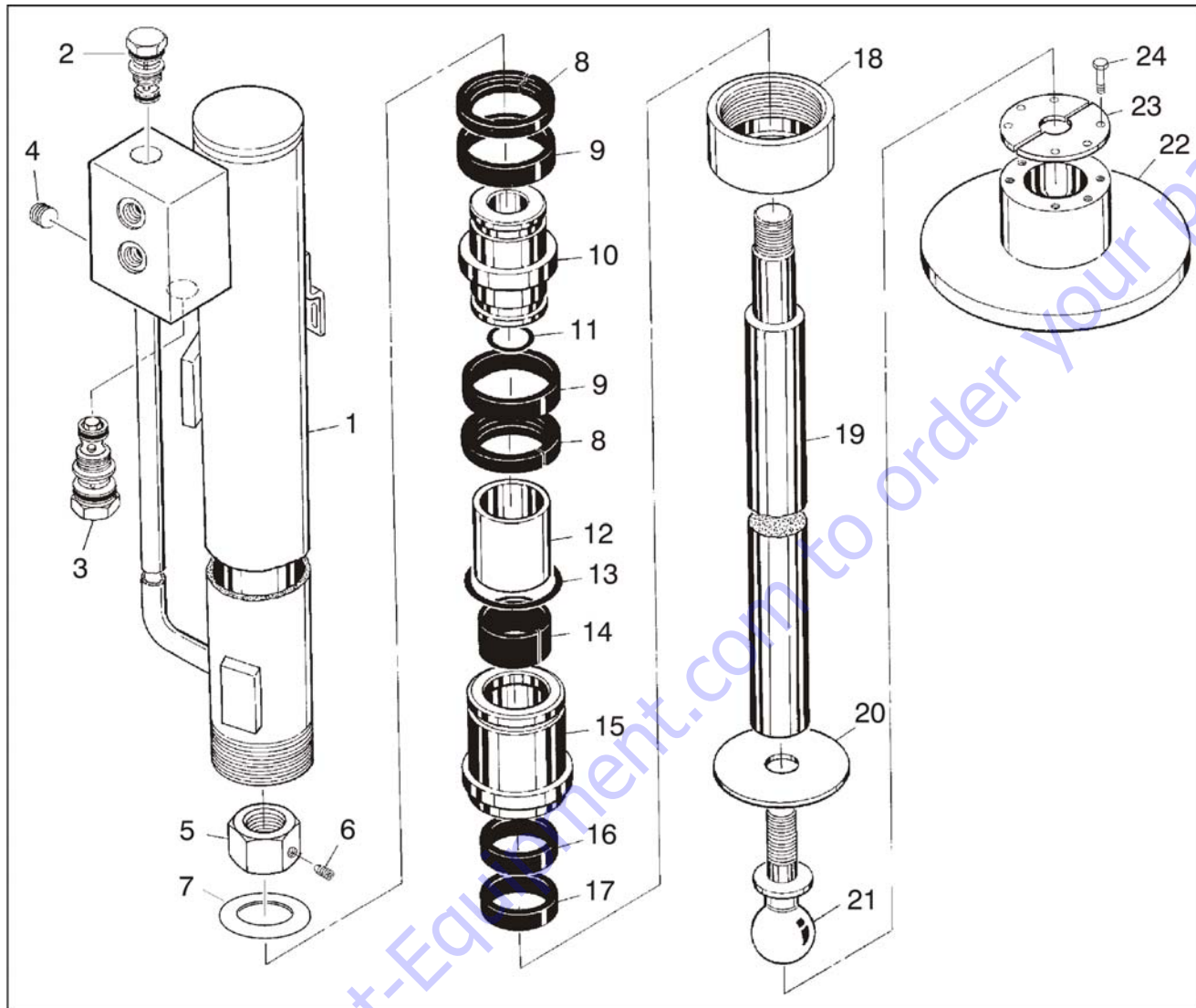

- | | | | |
|--------------------------|-----------------------------|----------------|-------------------|
| 1. Barrel | 7. Flatwasher, 11/4" Narrow | 13. O-Ring | 19. Rod |
| 2. Counter Balance Valve | 8. Guidelock | 14. Wear Ring | 20. Plate |
| 3. Check Valve | 9. Polyseal | 15. Head | 21. Trailer Ball |
| 4. Plug | 10. Piston | 16. Hydrolock | 22. Jack Pad |
| 5. Nut | 11. O-Ring | 17. Wiper Seal | 23. Retainer Ring |
| 6. Locking Screw | 12. Spacer Tube | 18. Cap | 24. Bolt |

Figure 2-17. Leveling Jack Assembly - (Prior to S/N 105371)

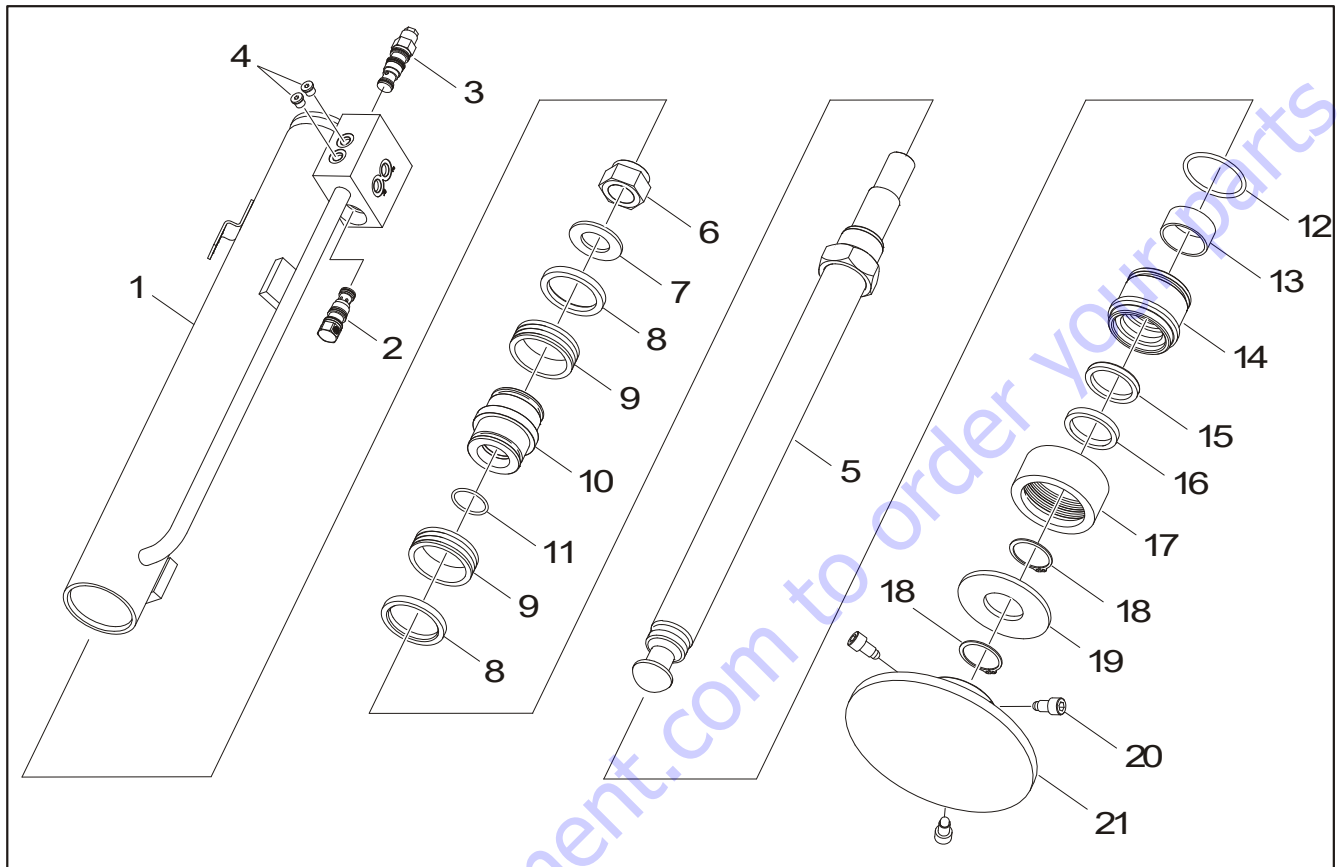

- | | | | |
|--------------------------|-----------------------------|--------------------|-----------------|
| 1. Barrel | 7. Flatwasher, 11/4" Narrow | 13. Wear Ring | 19. Plate |
| 2. Check Valve | 8. Guidelock | 14. Head | 20. Screw, 1/2" |
| 3. Counter Balance Valve | 9. Polyseal | 15. Hydrolock | 21. Jack Pad |
| 4. Plug | 10. Piston | 16. Wiper Seal | |
| 5. Rod | 11. O-Ring | 17. Cap | |
| 6. Nut | 12. O-Ring | 18. Retaining Ring | |

Figure 2-18. Leveling Jack Assembly - (S/N 105371to S/N 141689)

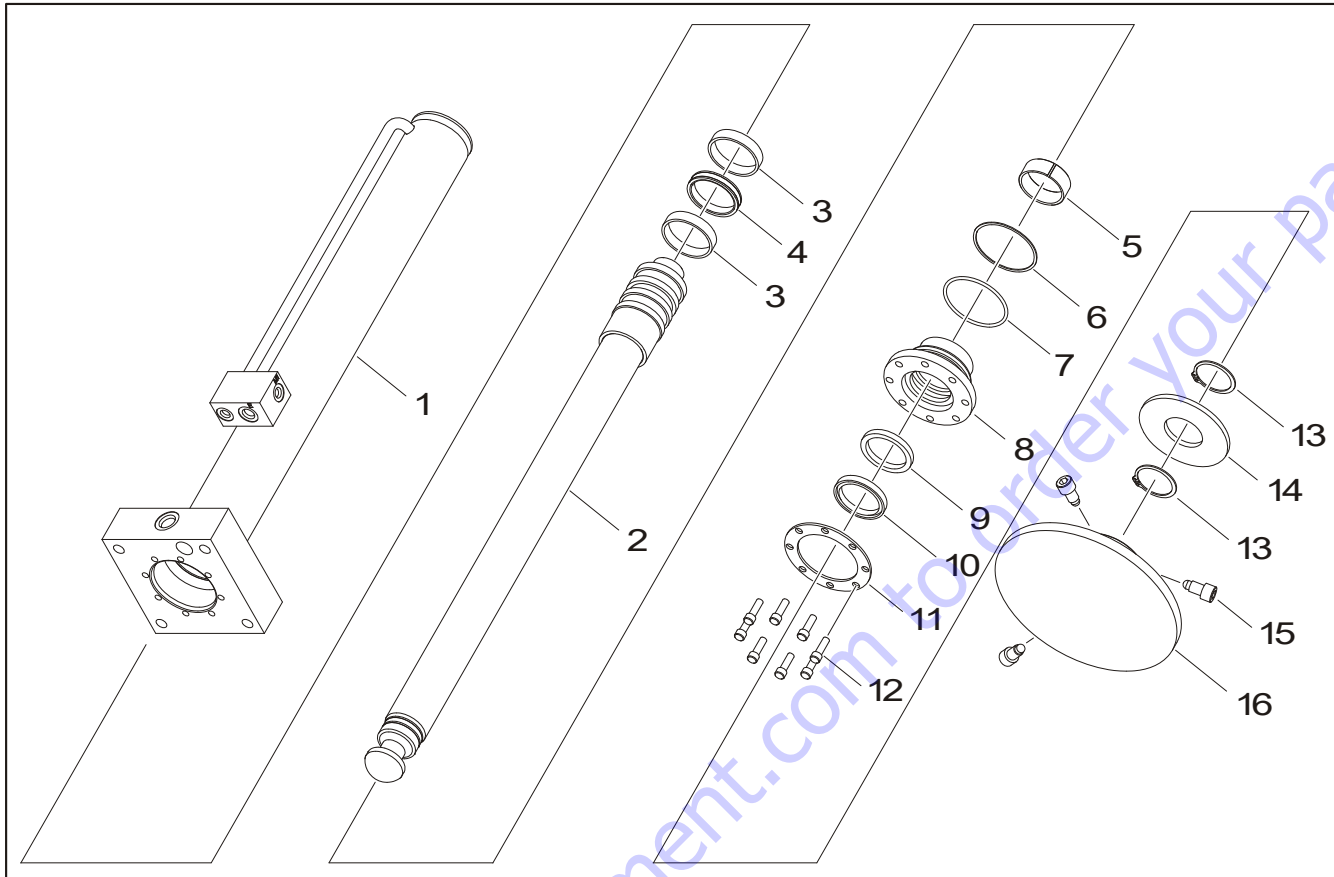

- | | | | |
|--------------|-----------------|------------------|--------------------|
| 1. Barrel | 5. Wear Ring | 9. Polyseal | 13. Retaining Ring |
| 2. Rod | 6. O-Ring | 10. Wiper Seal | 14. Plate |
| 3. Wear Ring | 7. Back-Up Ring | 11. Washer Ring | 15. Screw, 1/2" |
| 4. Seal | 8. Head | 12. Screw, 5/16" | 16. Jack Pad |

Figure 2-19. Leveling Jack Assembly - (AUS Spec: S/N 128985 to Present & CE Spec: S/N 141689 to Present)

2.12 LIMIT SWITCH ADJUSTMENT

Platform Limit Switch

The platform limit switch is located on the left side of the frame of the machine. When activated, the switch cuts out the High Drive function. Adjust the switch to activate when the platform is raised above the stowed position.

2.13 PRESSURE SETTING PROCEDURES

NOTE: Make all pressure adjustments with the engine operating and the hydraulic oil at normal operating temperature. In addition, all functions must be operated from the platform control station in order to achieve full pump speed. It may be necessary to use an assistant to adjust the pressure settings while operating the functions from the platform control station.

Main Pressure Adjustment

1. Install a pressure gauge at gauge port MP, located on the front upper right side of the valve body. The port is identified by a stamping on the valve body. Disconnect lift-up solenoid connector.
2. From the Ground control panel, activate the lift up function.
3. Bottom out the Lift Up function and adjust the main pressure to 3300 psi (228 bar). Reconnect lift-up solenoid connector.

Lift Relief Adjustments

1. Install a pressure gauge at gauge port MP, located on the front upper right side of the valve body. The port is identified by a stamping on the valve body.
2. From the platform control station, activate the Lift Up function by selecting the lift control switch and positioning the joystick to the up position.
3. Bottom out the Lift Up function and adjust the Lift Up relief to 2300 psi (159 bar).
4. Remove the pressure gauge from gauge port MP.

Steer Relief Adjustment

1. Install a pressure gauge at gauge port MP, located on the lower right side of the valve body. The port is identified by a stamping on the valve body.
2. Activate the Steer Right function and check Steer pressure. If necessary, adjust Steer pressure to 1700 psi (117 bar).
3. Activate the Steer Left function and check Steer pressure. If necessary, adjust Steer pressure to 2300 psi (159 bar).
4. Remove the pressure gauge from gauge port MP.

Leveling Jack Relief Adjustment

1. Refer to Figure 2-20., Main Valve Block.
2. Install a pressure gauge, 5000 psi (345 bar) or higher, at port MP on the main valve block. Start the engine and activate jack retract.
3. When all jacks are retracted the gauge should read 2500 psi (172 bar).
4. Adjust the relief valve located on the leveling jack directional valve (refer to Figure 2-21.) clockwise to increase, counter-clockwise to decrease. (The relief valve is on the same face as the solenoid valves).
5. Remove the pressure gauge from gauge port MP.

Main Valve Components

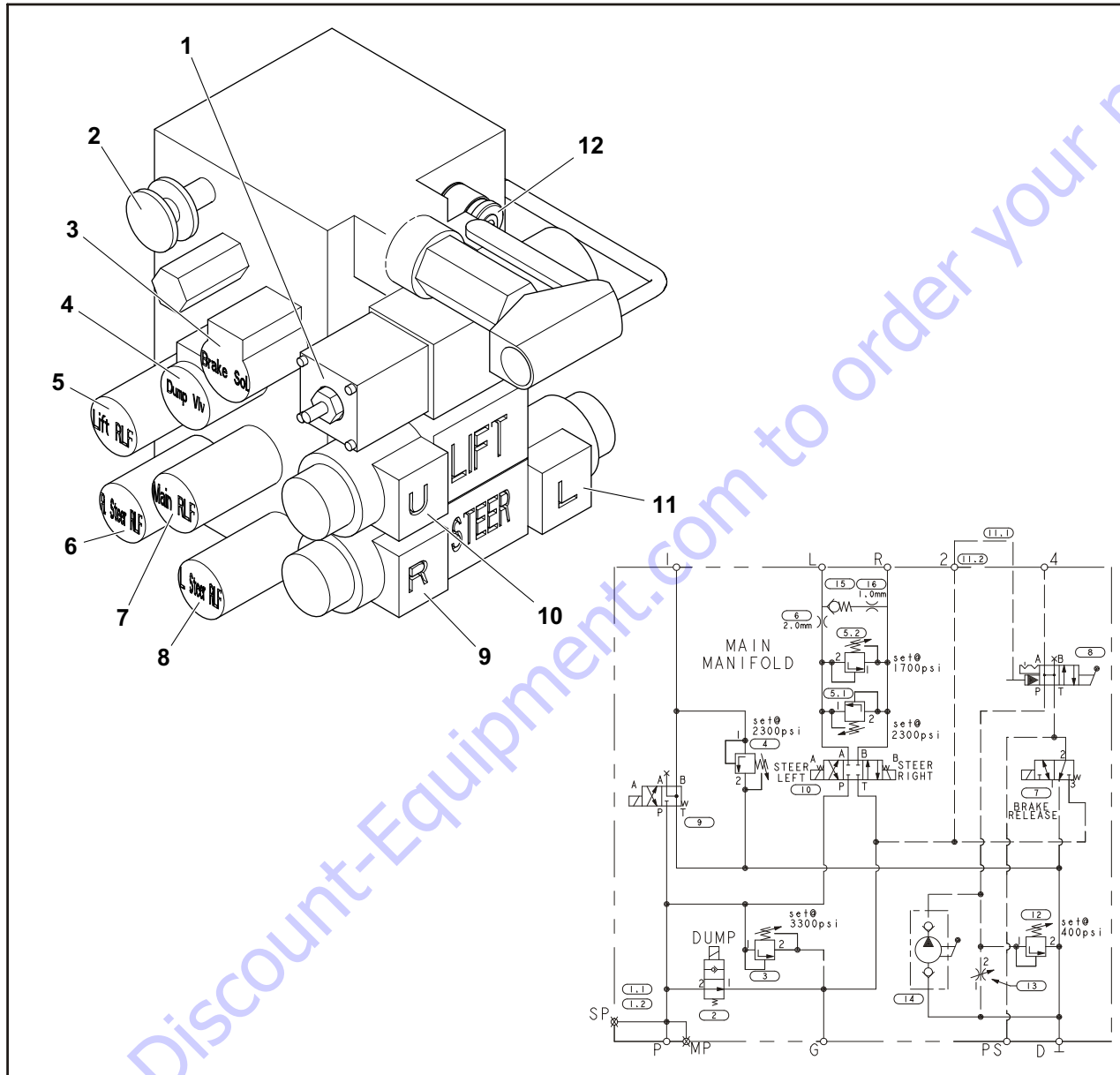

- | | | |
|------------------------------|-------------------------|---------------------------|
| 1. Tow Brake Release Acuator | 5. Lift Relief | 9. Steer Solenoid (Right) |
| 2. Valve Knob | 6. Steer Relief (Right) | 10. Lift Solenoid |
| 3. Brake Solenoid | 7. Main Relief | 11. Steer Solenoid (Left) |
| 4. Dump Valve | 8. Steer Relief (Left) | 12. MP |

Figure 2-20. Valve Components

Leveling Jacks Directional Valve

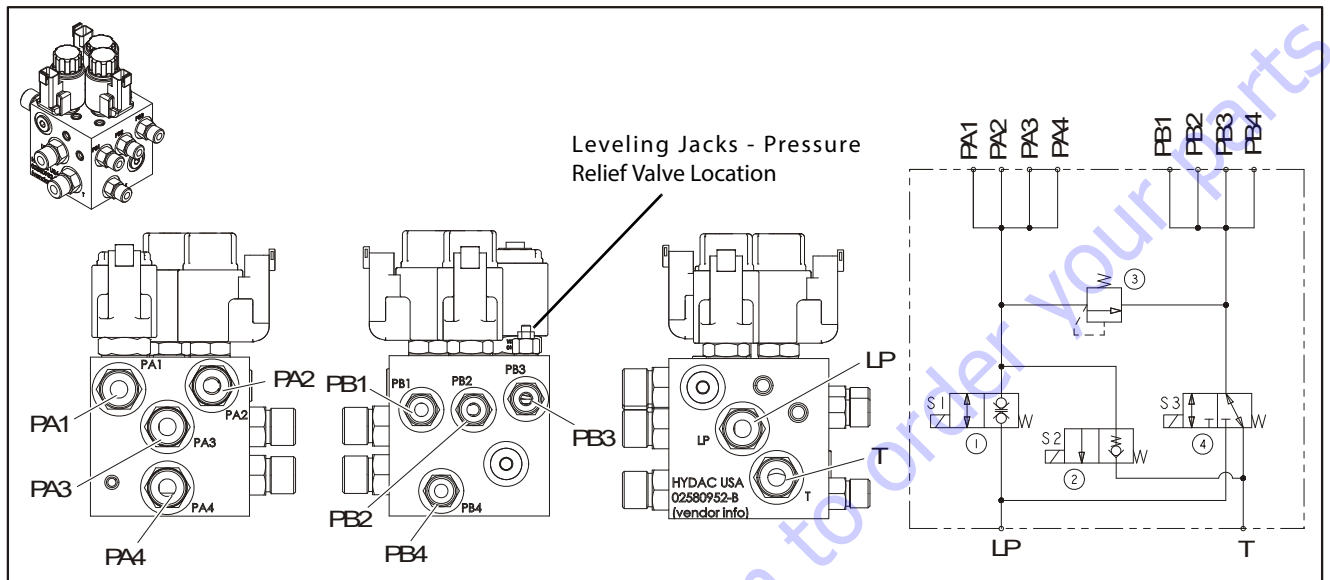

Figure 2-21. Leveling Jacks Directional Valve

Table 2-3. Leveling Jacks Directional Valve Torque Specs

Item	Torque
PA4	40 lb-ft (54 Nm)
PB4	23 lb-ft (31 Nm)
T	40 lb-ft (54 Nm)

2.14 DRIVE PUMP START-UP PROCEDURE

NOTICE

THE FOLLOWING PROCEDURE SHOULD ALWAYS BE PERFORMED WHEN STARTING A NEW PUMP OR WHEN RESTARTING AN INSTALLATION IN WHICH EITHER THE PUMP OR MOTOR HAVE BEEN REMOVED FROM THE SYSTEM.

THE FOLLOWING PROCEDURE SHOULD ALWAYS BE PERFORMED WHEN STARTING A NEW PUMP OR WHEN RESTARTING AN INSTALLATION IN WHICH EITHER THE PUMP OR MOTOR HAVE BEEN REMOVED FROM THE SYSTEM.

THE FOLLOWING PROCEDURE MAY REQUIRE THE MACHINE TO BE DISABLED (WHEELS RAISED OFF THE GROUND, DRIVE FUNCTION DISCONNECTED, ETC.) WHILE PERFORMING THE PROCEDURE IN ORDER TO PREVENT INJURY TO TECHNICIAN AND OTHER PERSONNEL. TAKE NECESSARY SAFETY PRECAUTIONS BEFORE MOVING THE MACHINE.

Prior to installing pump and/or motor, inspect unit(s) for damage incurred during shipping and handling. Make certain all system components (reservoir, hoses, valves, fittings, heat exchanger, etc.) are clean prior to filling with hydraulic fluid.

Fill reservoir with recommended hydraulic fluid, which should be passed through a 10 micron (nominal, no bypass) filter prior to entering the reservoir. The use of contaminated fluid will cause damage to components, which may result in unexpected machine movement.

The inlet line leading from the reservoir to the pump should be filled prior to start-up. Check inlet line for properly tightened fittings and make sure it is free of restrictions and air leaks.

Be certain to fill pump and/or motor housing with clean hydraulic fluid prior to start-up. Fill housing by pouring filtered oil into upper case drain port.

Install a 0 to 500 psi (0 to 35 bar) pressure gauge in the charge pressure gauge port to monitor charge pressure during start-up.

It is recommended that the external control input signal electrical connections be disconnected at the pump control until after initial start-up. This will allow the pump to remain in its neutral position.

“Jog” or slowly rotate prime mover until charge pressure starts to rise. Start prime mover and run at the lowest possible RPM until charge pressure has been established. Excess air may be bled from high pressure lines through high pressure gauge ports.

WARNING

DO NOT START PRIME MOVER UNLESS PUMP IS IN NEUTRAL POSITION (0 DEGREES SWASHPLATE ANGLE). TAKE PRECAUTIONS TO PREVENT MACHINE MOVEMENT IN CASE PUMP IS ACTUATED DURING INITIAL START-UP.

Once charge pressure has been established, increase speed to normal operating RPM. Charge pressure should be approximately 300 psi (20.7 bar) minimum. If charge pressure is incorrect, shut down and determine cause for improper pressure.

WARNING

INADEQUATE CHARGE PRESSURE WILL AFFECT THE OPERATOR'S ABILITY TO CONTROL THE MACHINE.

Shut down prime mover and connect external control input signal. start prime mover, checking to be certain pump remains in neutral. with prime mover at normal operating speed, slowly check for forward and reverse machine operation.

Charge pressure should remain at 300 psi to 320 psi (20.7 bar to 22.1 bar) minimum during forward or reverse operation. Continue to cycle slowly between forward and reverse for at least five minutes.

Shut down prime mover, remove gauges, and plug ports. Check reservoir level and add fluid if necessary

2.15 AUTOMATIC CHOKE - FIELD ADJUSTMENT (DF-750)

Inspection

NOTE: All automatic choke assemblies have been pre-set to operate between 20°F and 100°F with little or no adjustment. If the machine will be operated for prolonged use outside these temperature ranges, adjustments could be made to improve performance of the engine.

The machine will take time to warm up and you may experience low power or rough running for the first few minutes of operation or until the engine warms up. **LET THE ENGINE WARM UP.**

Make sure that the choke shaft operates freely and does not bind. This can be done without removing the air horn by rotating the bronze coupling with an eraser on a pencil or by removing the vacuum pull off line at the manifold and supply a small amount of vacuum to the hose. The choke rod should move freely using either method.

Adjustments

NOTE: If the choke rod is binding make sure the support bracket is straight

1. There are two adjustments Vertical (loosening the air horn nuts) and Horizontal (loosening the bracket to adaptor screws). These two adjustments should resolve any binding problem.
2. To adjust the choke at 70°F ambient, remove the air horn and reinstall the nut that holds the choke and support bracket securely making sure the choke moves freely.
3. Loosen the 3 top cover screws and rotate the top cover till the choke butterfly is closed with 1/32 in space between the plate and the wall of the carburetor.
4. If the ambient temperature is less than 70°F the top cover counter should be rotated CCW 1 mark for every 5°F less than 70°F.

5. If the ambient temperature is more than 70°F the top cover counter should be rotated CW 1 mark for every 5°F less than 70°F.

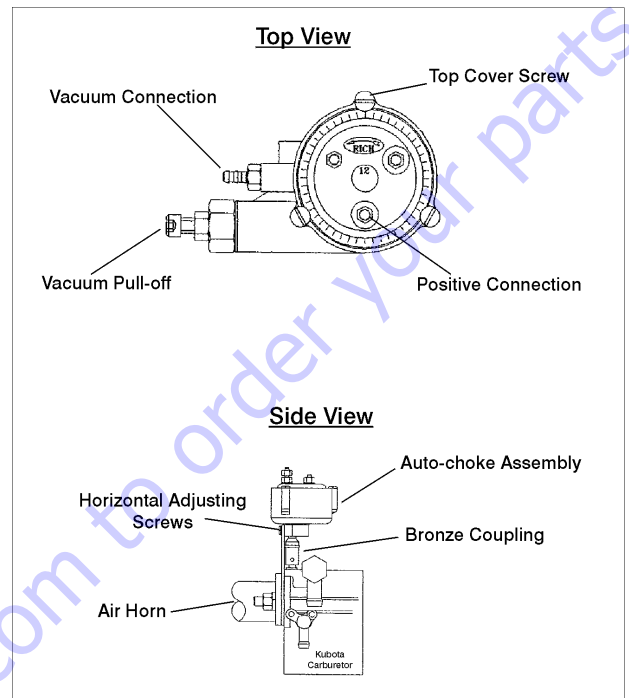

Figure 2-22. Automatic Choke Adjustment (DF-750)

Reassembly

Reassemble the air horn making sure the choke is not binding, test to insure that none of the settings have moved and the choke is not binding.

The vacuum pull off should be set such that when vacuum is applied to the choke system the choke butterfly is full open.

NOTE: If the machine starts and stalls immediately or if it is extremely cold, limiting the choke pull off to 75% to 90% may improve the performance of the machine. No adjustment is normally required.

Diesel Engine

NOTE: Never run the fuel tank dry. Diesel engines cannot be restarted after running out of fuel until the fuel system has been air-vented or 'bled' of air. See the Kubota Instruction Manual for the proper procedure.

2.16 JOYSTICK CONTROLLER

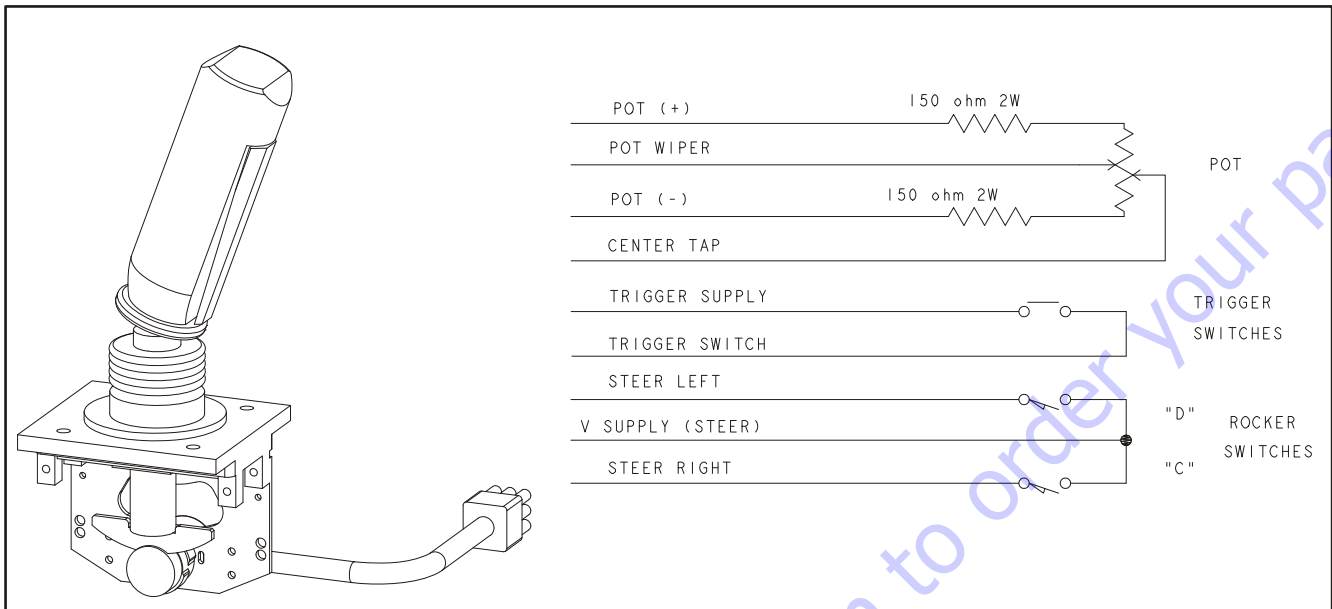

Figure 2-23. Joystick Controller - (JLG P/N 1600308)

Table 2-4. Joystick Specifications

Input Voltage	4.3V(±0.1V)
Centered Output Voltage	2.2V(±0.1V)
Full Positive (Rev) Deflection Output Voltage	4.0V(±0.1V)
Full Negative (Fwd) Output Voltage	0.4V(±0.1V)

Table 2-5. Joystick Plug Loading Chart

Terminal	Color	Function
1	Yellow	Steer Right
2	Green	Steer Left
3	Brown	Pot Wiper
4	Red	Handle Common
5	N/A	Not Connected
6	White/Red	Pot (+)
7	Violet	Trigger Switch
8	Blue	Trigger Supply
9	White/Black	Pot (-)

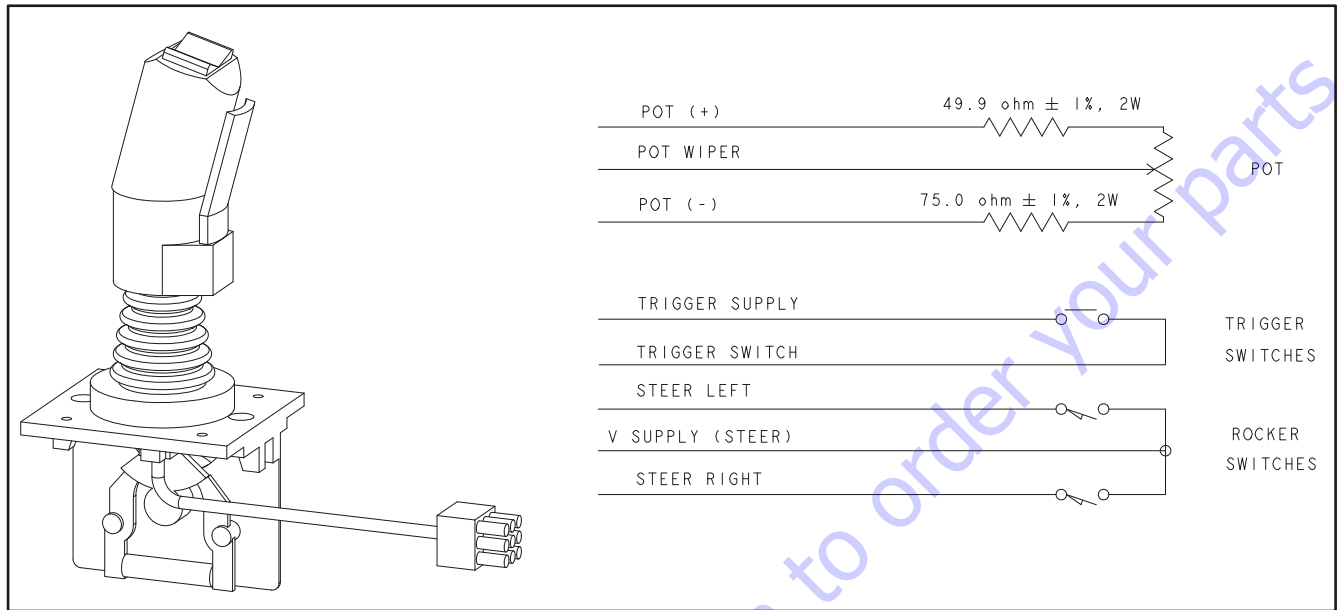

Figure 2-24. Joystick Controller - (JLG P/N 1600403)

Table 2-6. Joystick Specifications

Input Voltage	5V
Centered Output Voltage	4.25V to 2.60V
Reverse Voltage	4.60V to 4.80V
Forward Voltage	0.40V to 0.60V

Table 2-7. Joystick Plug Loading Chart

Terminal	Color	Function
1	Yellow	Steer Right
2	Green	Steer Left
3	Brown	Pot Wiper
4	Red	Handle Common
5	N/A	Not Connected
6	White/Red	Pot (+)
7	Violet	Trigger Switch
8	Blue	Trigger Supply
9	White/Black	Pot (-)

2.17 TILT SENSOR

Tilt Sensor, JLG P/N 4000006:

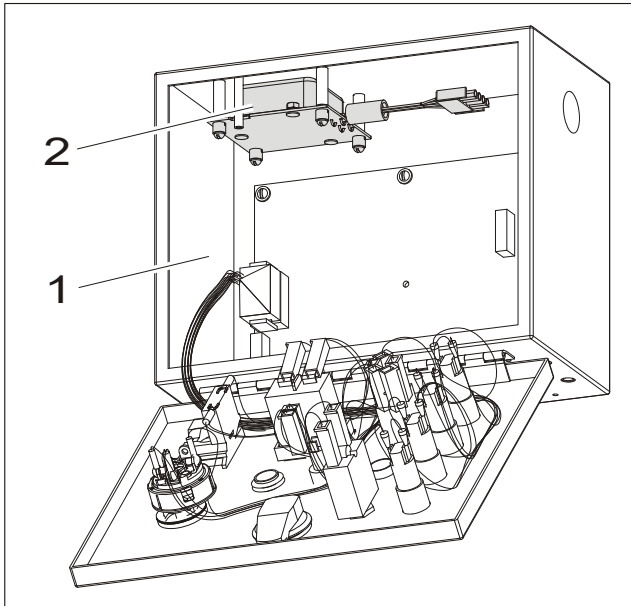

1. Ground Control Box
2. Tilt Sensor (JLG P/N 4000006)

Figure 2-25. Tilt Sensor Location

TILT SENSOR REMOVAL:

NOTE: Refer to Figure 2-26., Tilt Sensor Removal for numbers in parenthesis.

1. Disconnect the batteries.
2. Open the Ground Control Box to gain access to the Tilt Sensor Assembly.
3. Remove the four Screws (2) and Lockwashers (3) to remove the Tilt Sensor (1) from the Ground Control Box.

NOTE: Follow the above procedures in reverse order when installing the tilt sensor assembly. After installing, be sure to calibrate the tilt sensor (refer to Section 2.18, Calibrations).

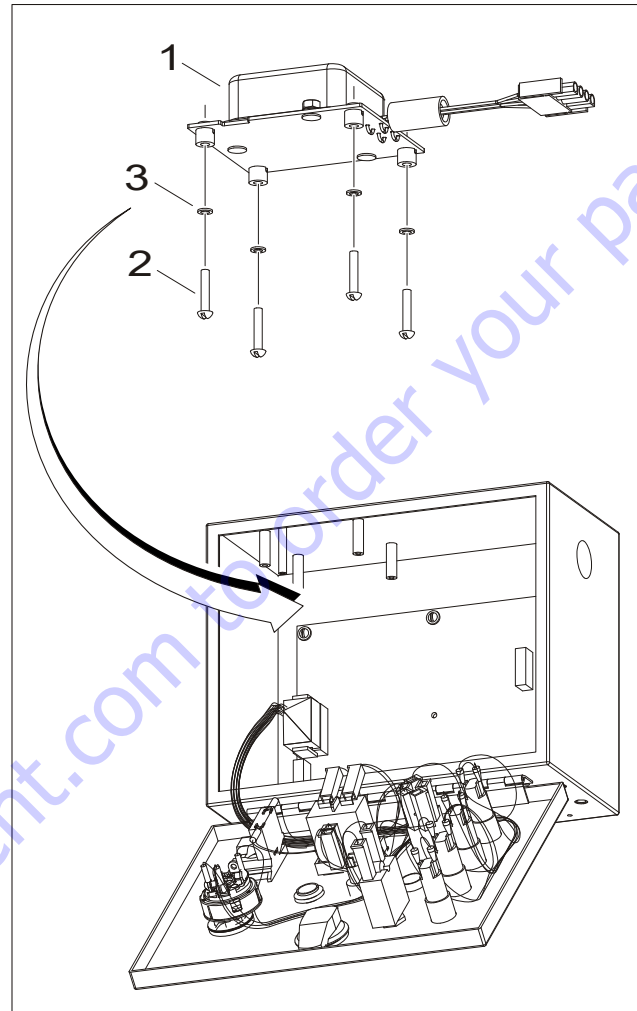

1. Tilt Sensor (JLG P/N 4000006)
2. Screw, 6-32 x 3/4
3. Lockwasher

Figure 2-26. Tilt Sensor Removal

Table 2-8. Tilt Sensor Harness Chart

Wire Color	Function	Connector Pin
Red	VCC	1
Black	Ground	4
Blue	PWMX	2
Yellow	PWMY	3

Tilt Sensor, JLG P/N 4000021:

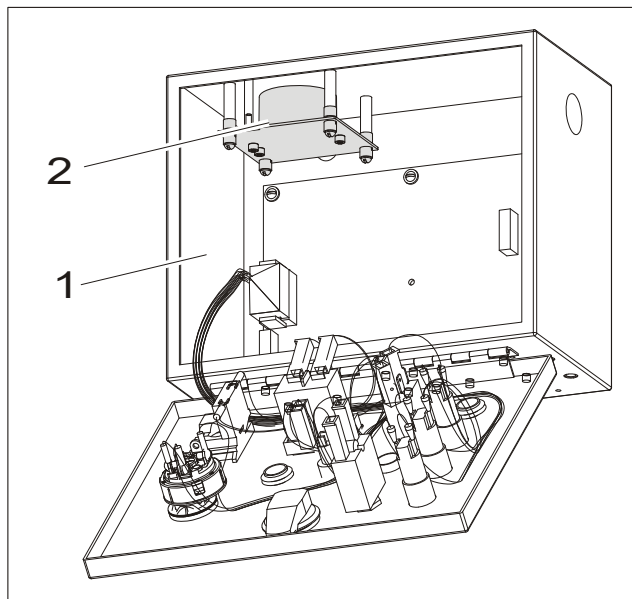

- 1. Ground Control Box
- 2. Tilt Sensor Assembly (JLGP/N 1810140)

Figure 2-27. Tilt Sensor Location

TILT SENSOR REMOVAL:

NOTE: Refer to Figure 2-28., Tilt Sensor Removal for numbers in parenthesis.

1. Disconnect the batteries.
2. Open the Ground Control Box to gain access to the Tilt Sensor Assembly.
3. Remove the four Screws (3), Lockwashers (4), Standoff Insulators (5), and Washers (6) to remove the Tilt Sensor (1) and Sensor Mount (2) from the Ground Control Box.
4. The Tilt Sensor (1) can be removed from the Sensor Mount (2) by removing the three Screws (7).

NOTE: Follow the above procedures in reverse order when installing the tilt sensor assembly. After installing, be sure to calibrate the tilt sensor (refer to Section 2.18, Calibrations).

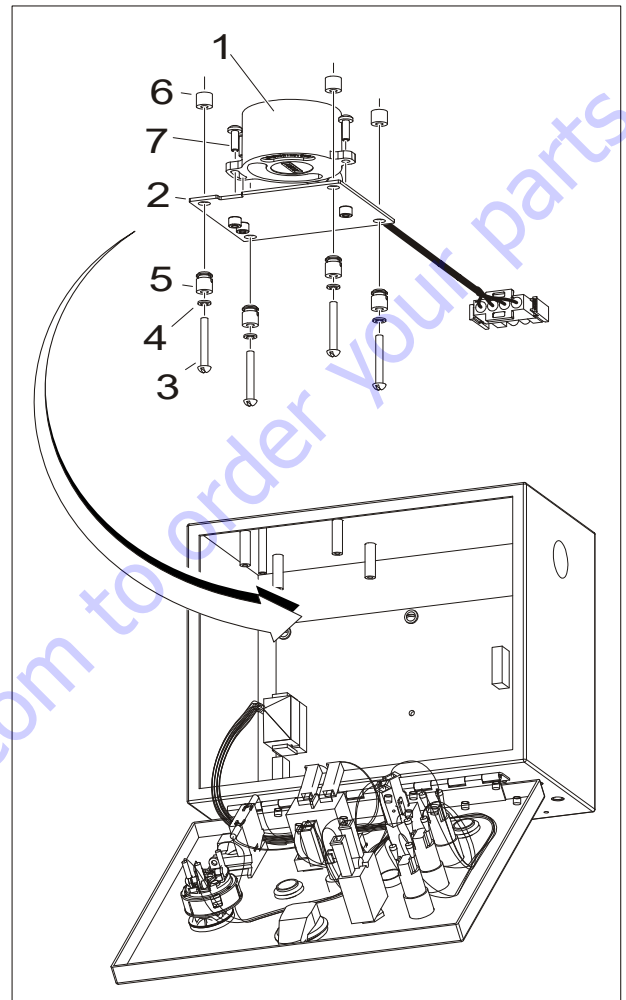

- 1. Tilt Sensor (JLGP/N 4000021)
- 2. Sensor Mount
- 3. Screw, 6-32x1
- 4. Lockwasher
- 5. Standoff Insulator
- 6. Washer, 0.313x0.250 Nylon
- 7. Screw, M3.5x0.6x10

Figure 2-28. Tilt Sensor Removal

Table 2-9. Tilt Sensor Harness

Wire Color	Function	Connector Pin
Red	VCC	1
Green	PWMX	2
White	PWMY	3
Black	Ground	4

2.18 CALIBRATIONS

Refer "Changing the Access Level of the Hand Held Analyzer" to go to access level 1.

Tilt Sensor Calibration:

1. Drive the machine onto a measured level surface ($\pm 0.5^\circ$ for both x and y axis).
2. Using the Analyzer, go to MENU: CALIBRATION; TILT SENSOR. Press Enter. LEVEL VEHICLE will display. Press Enter again to calibrate.
3. Both axis' raw angles need to be within $\pm 5.0^\circ$, otherwise the machine is to unlevel and the software will prohibit calibration. Should this occur, attempt to dissect the three areas of error to find the primary contributor:
 - a. Machine mounting and/or grade:

With a digital level, measure the top of the Ground Control box for levelness. If unable to get a good reading, check the box's mounting surface for levelness.

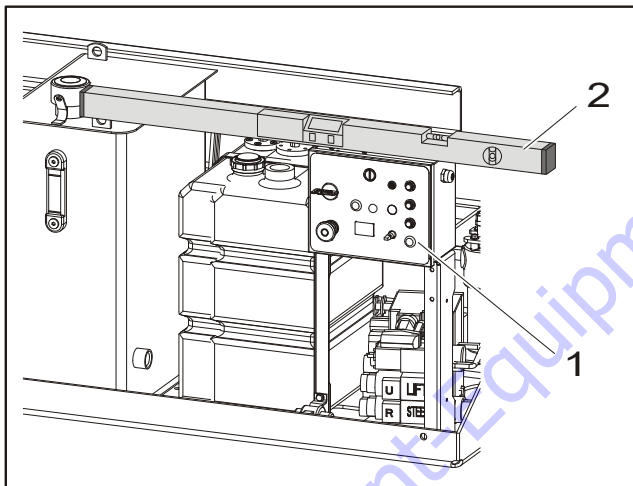

1. Ground Control Box
2. Digital Level

- b. Tilt sensor mounting on machine or wedged crooked in control box:

If the machine mounting/grade appears acceptable, open the Ground Control box carefully. Observe whether the tilt sensor is properly seated.

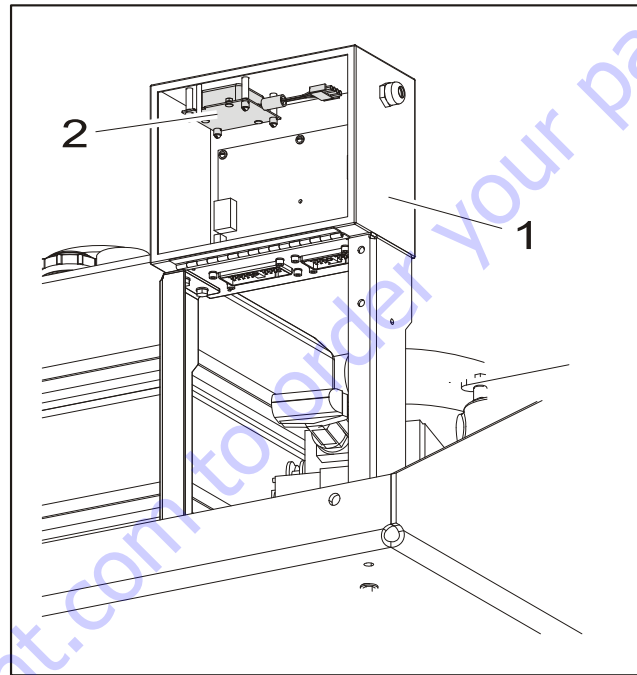

1. Ground Control Box
2. Tilt Sensor

- c. Tilt sensor has developed an offset shift:

Remove the tilt sensor from the Ground Control box, but keep both the tilt sensor and Ground Control box electrically connected. Level one axis of the tilt sensor and observe the raw reading (should be within $\pm 2.0^\circ$). Do the same for the other axis. If either axis is greater than $\pm 2.0^\circ$, replace the tilt sensor.

Some possible reasons that the tilt sensor will not calibrate are:

- a. The surface the machine is sitting on is off level by a few degrees (flat doesn't imply level; parking lots are often not level).
- b. The tilt sensor has failed one or both of the channels (X axis and Y axis).
- c. Tilt sensor has moisture intrusion that has shifted its output.
- d. Water and/or corrosion in the box has corrupted electrical connections or caused a tilt sensor or ground control board failure (observe any cracks in the box).
- e. The Ground Control Box, as mounted on the machine, does not allow the tilt sensor to be level.

For the following troubleshooting steps, a bubble level (smaller is better) will be needed and the machine must be on a level surface:

1. On the Analyzer, go to Diagnostics/System and read the tilt angle. If either angle reports $+20.0^\circ$, there is an electrical/electronic failure (tilt sensor, control board, electrical connections).
 - a. Open the Ground Control Box.
 - b. Disconnect the sensor and clean any corrosion off of the tilt sensor and control board connections.
 - c. Reassemble and test. If fault persists, replace tilt sensor.
2. If the Analyzer displays angles other than $+20.0^\circ$, attempt to calibrate. If machine will not calibrate, note the reason displayed on Analyzer:
 - a. SENSOR FAILURE – tilt sensor internal frequency is out of range (replace sensor).
 - b. NOT LEVEL - tilt sensor has either developed an offset or it is to unlevel as mounted on the machine.

Joystick Calibration (Software 1.5 and Higher and Higher)

Using the Analyzer, in Access Level 1, go to MENU: CALIBRATION: JOYSTICK and press ENTER.

1. Following the analyzer screen prompts:
 - a. Move the Joystick FORWARD and press ENTER.
 - b. Allow Joystick to be in CENTER position and press ENTER.
 - c. Move the Joystick REVERSE and press ENTER.
2. CAL COMPLETE or CAL FAILED will display on the analyzer.
3. Possible reasons if calibration failed:
 - a. The forward position must be a lower voltage than reverse position.
 - b. The difference between center and forward & center and reverse must be at least 1V.

2.19 ELECTRONIC CONTROL SYSTEM

Hand Held Analyzer

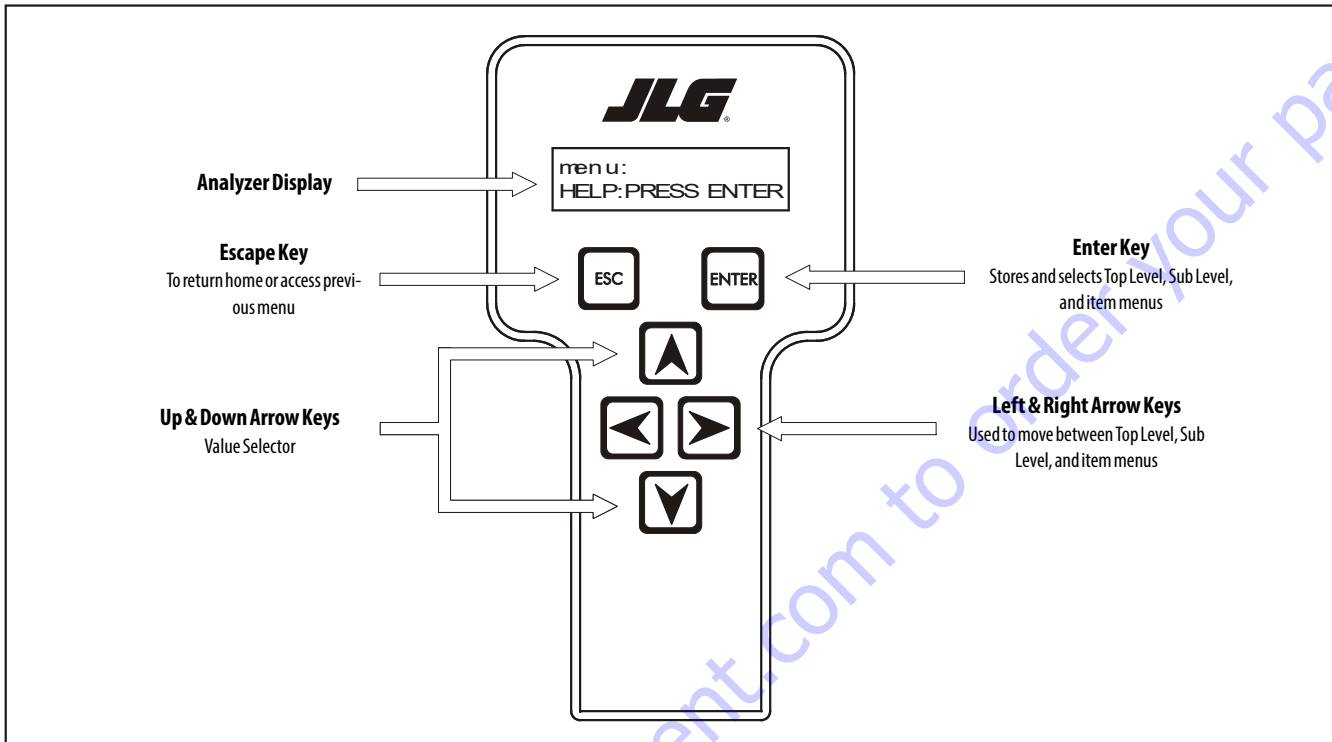

Figure 2-29. Hand Held Analyzer

To Connect the Hand Held Analyzer

1. Connect the four pin end of the cable supplied with the analyzer, to the top connection of the motor controller and connect the remaining end of the cable to the analyzer.

NOTE: The cable has a four pin connector at each end of the cable; the cable cannot be connected backwards.

2. Power up the Control System by turning the lower key to the platform position and pulling both emergency stop buttons on.

Using the Analyzer

With the machine power on and the analyzer connected properly, the analyzer will display the following:

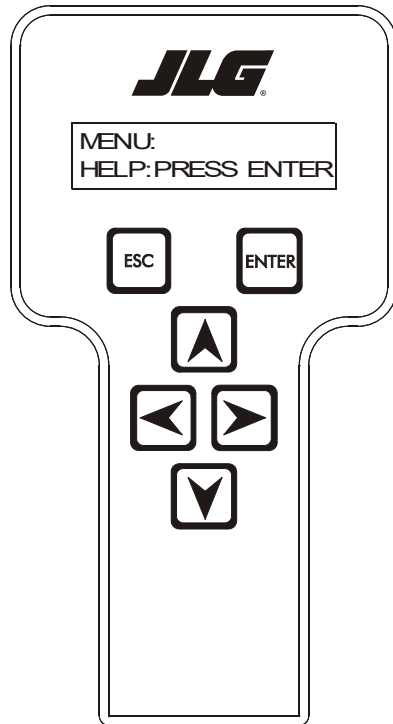

**HELP:
PRESS ENTER**

At this point, using the **RIGHT** and **LEFT** arrow keys, you can move between the top level menu items. To select a displayed menu item, press **ENTER**. To cancel a selected menu item, press **ESC**; then you will be able to scroll using the right and left arrow keys to select a different menu item.

The top level menus are as follows:

HELP
DIAGNOSTICS
ACTIVATE TESTS
ACCESS LEVEL
PERSONALITIES
MACHINE SETUP
LEVEL VEHICLE

If you press **ENTER**, at the **HELP:PRESS ENTER** display, and a fault is present during power up, the analyzer display will scroll the fault across the screen. If there was no fault detected during power up, the display will read: **HELP: EVERYTHING OK**

If **ENTER** is pressed again, the display moves to the following display:

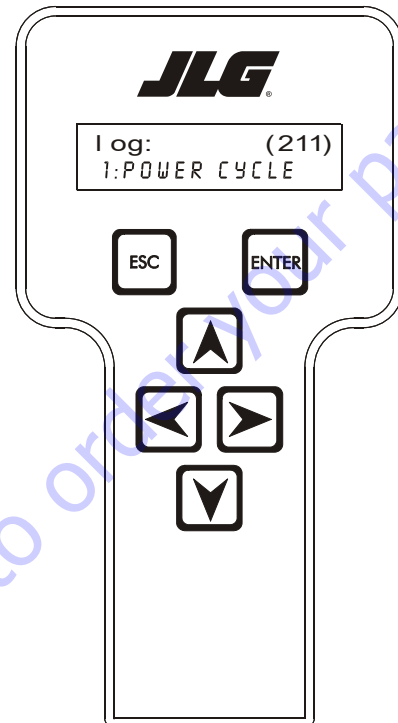

**LOGGED HELP
1: STARTUP (2/1)**

At this point, the analyzer will display the current fault, if any are present. You may scroll through the fault logs to view what the last 15 faults were. Use the right and left arrow keys to scroll through the fault logs. To return to the beginning, press **ESC** two times.

When a top level menu is selected, a new set of menu items may be offered; for example:

PLATFORM
DRIVE
LIFT SEL
SPEED SEL
HORN
ENGINE START
FUEL/GLOW
STEER LEFT
STEER RIGHT
JOYSTICK

Pressing **ENTER** with any of the above displayed menus, will display additional sub-menus within the selected menu. In some cases the next level is the parameter or information to be changed. Refer to the flow chart for what menus are available within the top level menus. You may only view the personality settings for selected menus while in access level 2.

Remember, you may always cancel a selected menu item by pressing the **ESC** key.

Changing the Access Level of the Hand Held Analyzer

When the analyzer is first connected, you will be in access level 2 which enables you to only view most configuration settings which cannot be changed until you enter a password to advance to a lower level. This ensures that a setting cannot be accidentally altered. To change the access level, the correct password must be entered. To enter the password, scroll to the **ACCESS LEVEL** menu. For example:

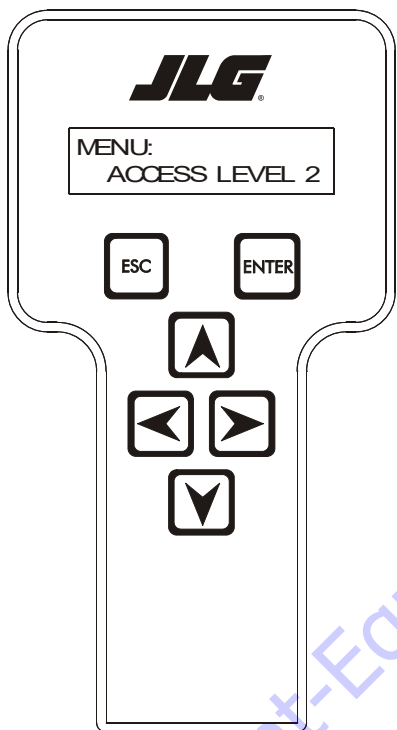

MENU:
ACCESS LEVEL 2

Press **ENTER** to select the **ACCESS LEVEL** menu.

Using the **UP** or **DOWN** arrow keys, enter the first digit of the password, 3.

Then using the **RIGHT** arrow key, position the cursor to the right one space to enter the second digit of the password.

Use the **UP** or **DOWN** arrow key to enter the second digit of the password which is 3.

Repeat this process until you have entered all five digits of the password which is **33271**.

Once the correct password is displayed, press **ENTER**.

The access level should display the following, if the password was entered correctly:

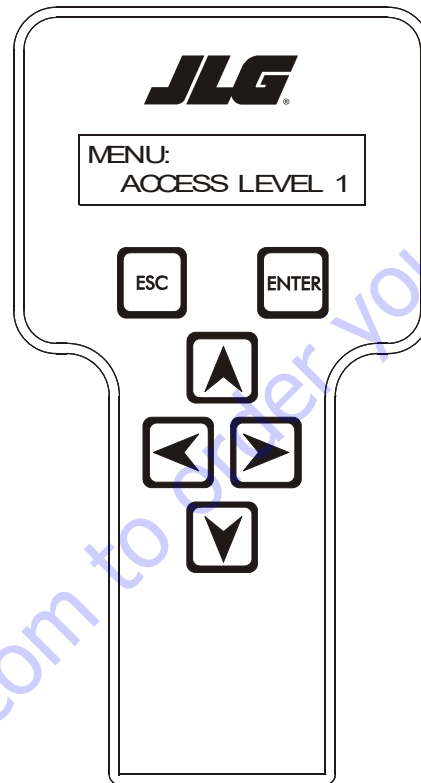

MENU:
ACCESS LEVEL 1

Repeat the above steps if the correct access level is not displayed or you can not adjust the personality settings.

Adjusting Parameters Using the Hand Held Analyzer

Once you have gained access to level 1, and a personality item is selected, press the UP or DOWN arrow keys to adjust its value, for example:

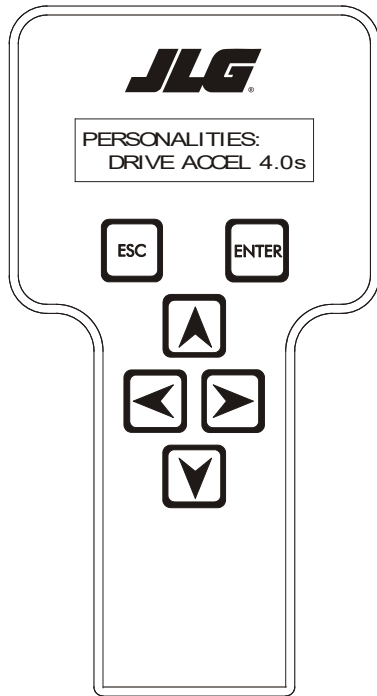

PERSONALITIES: DRIVE ACCEL 4.0s

There will be a minimum and maximum for the value to ensure efficient operation. The Value will not increase if the **UP** arrow is pressed when at the maximum value nor will the value decrease if the **DOWN** arrow is pressed and the value is at the minimum value for any particular personality. If the value does not change when pressing the up and down arrows, check the access level to ensure you are at access level 1.

Machine Setup

When a machine digit item is selected, press the **UP** or **DOWN** arrow keys to adjust its value, for example:

⚠ WARNING

FAILURE TO MAKE THE PROPER SETTINGS FOR THE PARTICULAR MACHINE CAN RESULT IN IMPROPER OPERATION.

CHANGING THESE SETTINGS MAY ADVERSELY AFFECT THE PERFORMANCE OF THE MACHINE.

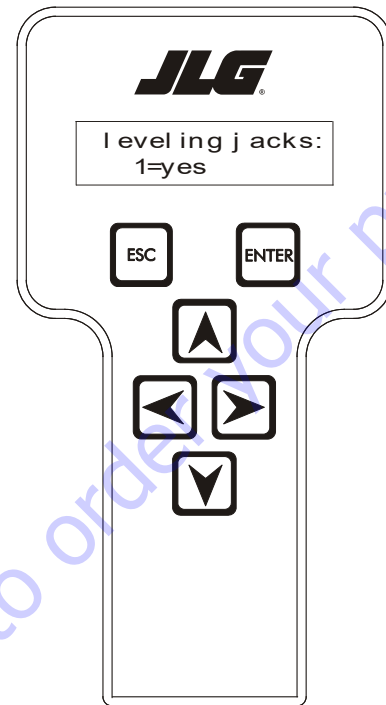

LEVELING JACKS: 1=YES

The effect of the machine digit value is displayed along with its value. The above display would be selected if the machine was equipped with a ground alarm and you wanted it to sound when driving. There are certain settings allowed to install optional features or select the machine model.

When selecting the machine model to match the size of the machine, the personality settings will return to default settings.

NOTE: Refer to the appropriate Machine Personality Settings Table, and the Machine Setup Table in the JLG Service Manual for the recommended factory settings.

Password 33271 will give you access to level 1, which will permit you to change all machine personality settings.

NOTICE

IT IS A GOOD PRACTICE TO AVOID PRESSURE-WASHING ELECTRICAL/ELECTRONIC COMPONENTS. SHOULD PRESSURE-WASHING BE UTILIZED TO WASH AREAS CONTAINING ELECTRICAL/ELECTRONIC COMPONENTS, JLG INDUSTRIES, INC. RECOMMENDS A MAXIMUM PRESSURE OF 750 PSI (52 BAR) AT A MINIMUM DISTANCE OF 12 INCHES (30.5 CM) AWAY FROM THESE COMPONENTS. IF ELECTRICAL/ELECTRONIC COMPONENTS ARE SPRAYED, SPRAYING MUST NOT BE DIRECT AND BE FOR BRIEF TIME PERIODS TO AVOID HEAVY SATURATION.

2.20 FLASH CODES AND DESCRIPTIONS

Table 2-10. Help Messages and Flash Codes - Software P1.X

FLASH CODE	HELP MESSAGES AND FLASH CODES
No Flash Code	EVERYTHING OK
	GROUND MODE OK
	ALARM SOUNDING - TILTED & ABOVE ELEVATION Platform is elevated and the chassis is not level.
	DIFFERENT FUNCTION SELECTED & IGNORED A function (i.e. Drive, Lift, etc.) is active and the operator has selected another function. The system has ignored the new selection.
	DRIVING AT CUTBACK - ABOVE ELEVATION Platform is elevated and the machine is in the drive mode of operation.
	FUNCTION SELECTED BUT TRIGGER SWITCH OPEN A function (i.e. Drive, Lift, etc.) has been selected by the operator, but the trigger switch is not active (closed).
	JOYSTICK MOVED BUT NO FUNCTION SELECTED The joystick was moved out of the center position before a function was selected.
	DRIVE PREVENTED - ABOVE DRIVE CUTOFF HEIGHT Machine is elevated above the drive cutoff height.
2-1	STARTUP A new system power up has occurred since the last help message.
2-2	FUNCTIONS LOCKED OUT - SHORT TO PLATFORM ROW INPUT DETECTED Battery power has been detected on a row input (pins J1-8, J1-9, or J1-13).
	FUNCTION PROBLEM - DRIVE PERMANENTLY SELECTED Drive select switch in the platform control box closed at start up or for more than ten seconds. Release switch to clear fault.
	FUNCTION PROBLEM - LIFT PERMANENTLY SELECTED Lift select switch in the platform control box closed at start up or for more than ten seconds. Release switch to clear fault
	FUNCTION PROBLEM - O/R or L/J PERMANENTLY SELECTED An outrigger select switch in the platform control box closed at start up or for more than ten seconds. Release switch to clear fault
	FUNCTION PROBLEM - START PERMANENTLY SELECTED Start switch in the platform control box closed at start up. Release switch to clear fault
	FUNCTION PROBLEM - GLOW PLUG PERMANENTLY SELECTED Glow plug switch in the platform control box closed at start up. Release switch to clear fault
	FUNCTION PROBLEM - STEER LEFT PERMANENTLY SELECTED Steer left switch in the platform control box closed at start up. Release switch to clear fault
	FUNCTION PROBLEM - STEER RIGHT PERMANENTLY SELECTED Steer right switch in the platform control box closed at start up. Release switch to clear fault
	FUNCTION PROBLEM - HORN PERMANENTLY SELECTED Horn switch in platform control box closed at start up. Release switch to clear fault.
	FUNCTION PROBLEM - JOYSTICK CALIBRATION FAULTY The Personalities for the Joystick are improperly adjusted or a joystick calibration attempt failed. Re-adjust or recalibrate.
	JOYSTICK FAULTY - WIPER OUT OF RANGE The joystick wiper signal input is outside the acceptable voltage range. The wiper wire being off, the wiper wire shorted to battery power, or the wiper wire shorted to battery negative could cause this.
	JOYSTICK FAULTY - STEER SWITCHES ACTIVE TOGETHER Both the steer left and steer right inputs are closed at the same time. A short in the steer switch wiring or a failed steer switch can cause this.
	FUNCTION LOCKED OUT - JOYSTICK NOT CENTERED Selected function is not allowed because the joystick is not centered. Return joystick to center and reselect function.

Table 2-10. Help Messages and Flash Codes - Software P1.X

FLASH CODE	HELP MESSAGES AND FLASH CODES
2-2	FUNCTION PROBLEM - JOYSTICK CALIBRATION FAULTY The Personalities for the Joystick are improperly adjusted or a joystick calibration attempt failed. Re-adjust or recalibrate
	FUNCTION PROBLEM - TRIGGER PERMANENTLY CLOSED Trigger switch in the platform control box closed at start up. Release switch to clear fault.
	TRIGGER CLOSED TOO LONG WHILE IN NEUTRAL Trigger switch in the platform control box closed for more than ten seconds while the joystick is in the neutral position. Release switch to clear fault.
2-3	FUNCTION PROBLEM - LIFT PERMANENTLY SELECTED Lift switch (up or down) in the ground control box closed at start up. Release switch to clear fault
	FUNCTION PROBLEM - START PERMANENTLY SELECTED Start switch in the ground control box closed at start up. Release switch to clear fault
	FUNCTION PROBLEM - GLOW PLUG PERMANENTLY SELECTED Glow plug switch in the ground control box closed at start up. Release switch to clear fault
	NO DATA FROM TILT SENSOR - NOT CONNECTED OR FAULTY No signal from the tilt switch. Check wiring and plug connections at the level sensor and at the ground control board.
2-5	DRIVE & LIFTUP PREVENTED - OSC AXLE NOT SET
	DRIVE & LIFTUP PREVENTED - FUNCTION CUTOFF ACTIVE
	ALL FUNCTIONS PREVENTED - FUNCTION CUTOFF ACTIVE
	PLATFORM OVERLOAD
	ELEV PROX PERMANENTLY CLOSED - CHECK PROX & CAM SWITCH ADJUSTMENT
	LEVEL PREVENTED - CHASSIS TILTED EXCESSIVELY
2-6	FRONT LEFT LEVELING JACK SHORT TO GROUND
	FRONT RIGHT LEVELING JACK SHORT TO GROUND
	REAR LEFT LEVELING JACK SHORT TO GROUND
	REAR RIGHT LEVELING JACK SHORT TO GROUND
	FRONT LEFT LEVELING JACK SHORT TO BATTERY
	FRONT RIGHT LEVELING JACK SHORT TO BATTERY
	REAR LEFT LEVELING JACK SHORT TO BATTERY
	REAR RIGHT LEVELING JACK SHORT TO BATTERY
3-3	OUTPUT ENERGIZED EXTERNALLY - CHECK WIRING
	OUTPUT SHORTED - CHECK WIRING
4-4	BATTERY VOLTAGE TOO LOW Battery voltage below 8.0V. Check battery and alternator.
	BATTERY VOLTAGE TOO HIGH Battery voltage above 16V. Check battery and alternator.
5-5	ENGINE SHUTDOWN – OVERSPEED The engine speed exceeded 4500 RPM for more than 2 seconds. Check throttle actuator for debris or interference, which prevents free movement of actuator. Recycle power to clear the fault and restart.
	ENGINE SHUTDOWN - OIL PRES / COOLANT TEMP The engine oil pressure was too low or the engine coolant temperature was too high for more than 10 seconds. Check engine fluid levels. Recycle power to clear fault and restart.
6-6	COMMUNICATION FAILURE: I/O MODULE

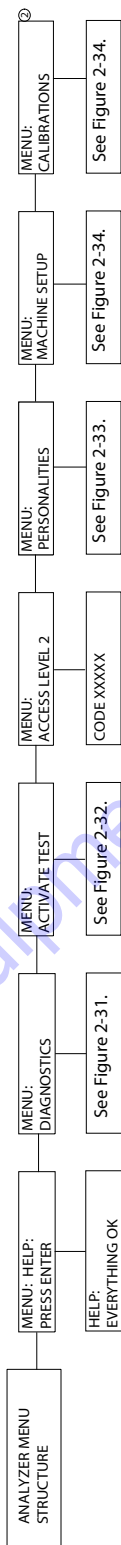

4170044-E
MAF03440

Go to Discount-Equipment.com to order your parts

Figure 2-30. Analyzer Flow Chart - Sheet 1 of 5



4170044-E
MAF03450

Figure 2-31. Analyzer Flow Chart - Sheet 2 of 5



4170044-E
MAF03460

Figure 2-32. Analyzer Flow Chart - Sheet 3 of 5

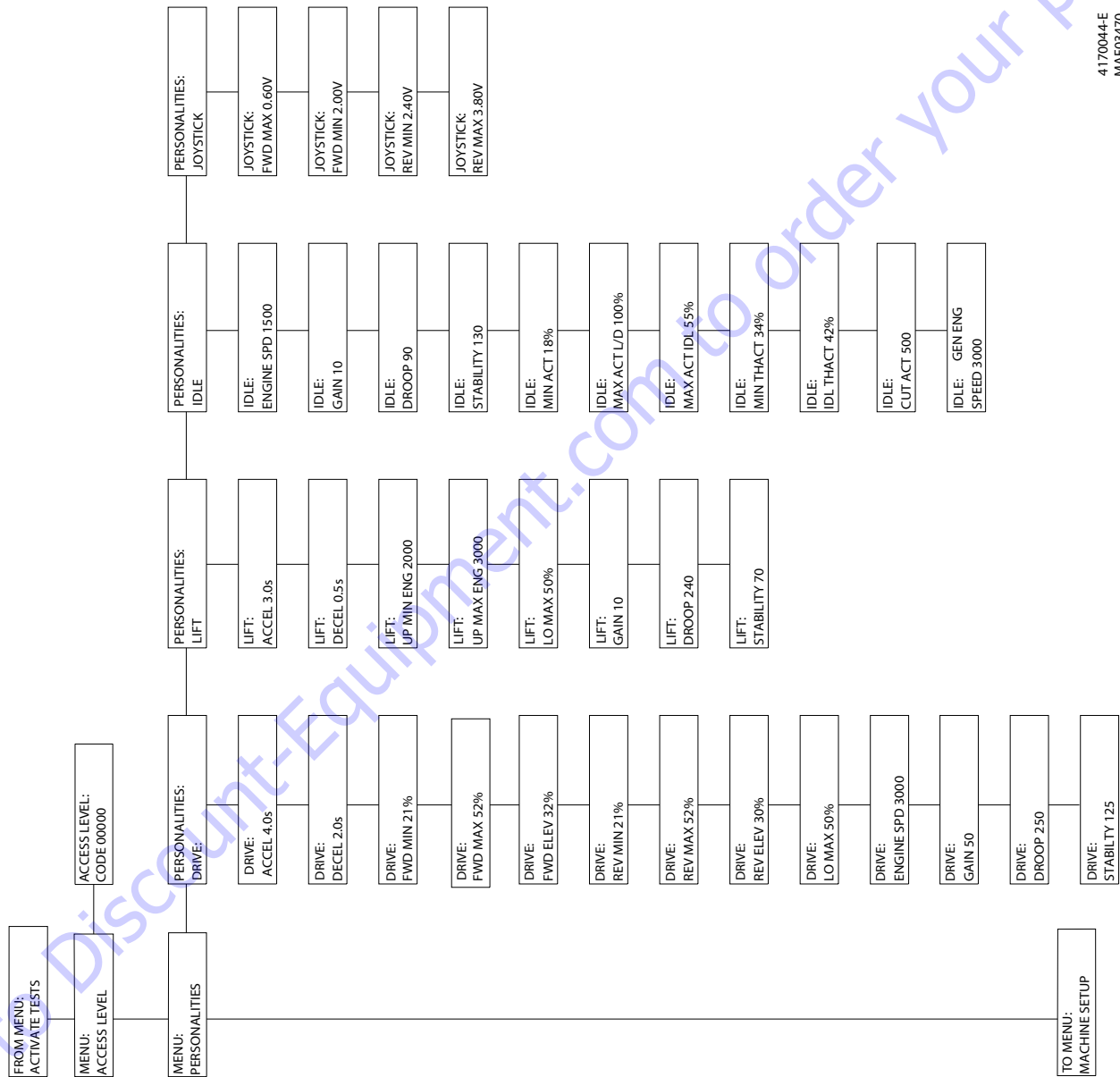

417004-E
MAF03470

Figure 2-33. Analyzer Flow Chart - Sheet 4 of 5

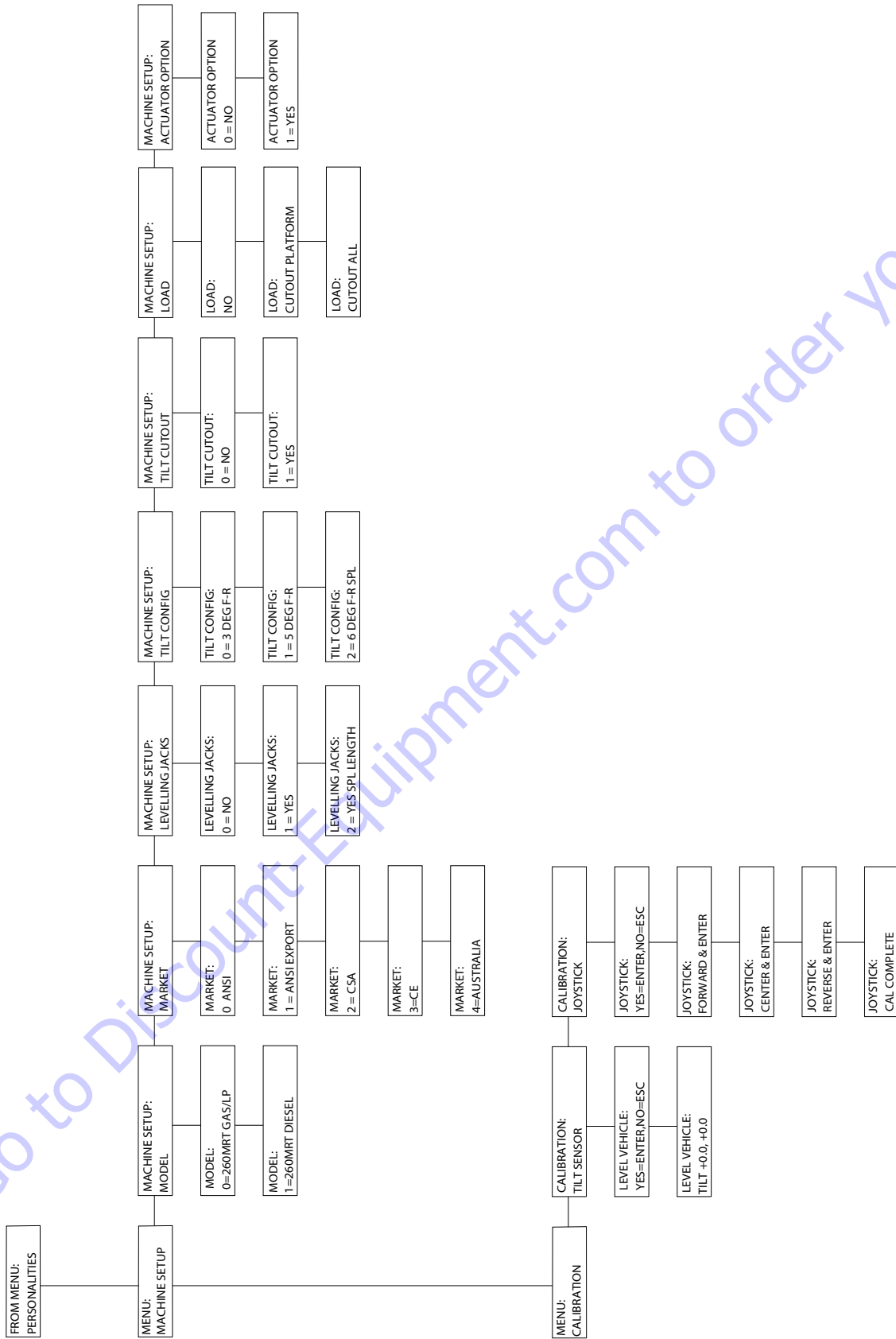

4170044-E
MAF03480

Figure 2-34. Analyzer Flow Chart - Sheet 5 of 5

2.21 MACHINE MODEL ADJUSTMENT

Table 2-11. Machine Model Adjustment

Adjustment	Adjustment range	Default Values - Gas	Default Values - Diesel
DRIVE			
Accel	1.0 to 5.0 sec	4	4
Decel	1.0 to 5.0 sec	2	2
FWD MIN	0 to 100%	21	21
FWD MAX	0 to 100%	52	52
FWD ELEV	0 to 35%	32	32
REV MIN	0 to 100%	21	21
REV MAX	0 to 100%	52	52
REV ELEV	0 to 35%	30	30
LO MAX	35 to 65%	50	50
ENGINE SPD	2800 to 3600 RPM	3600	3000
GAIN	0 to 999	180	50
DROOP	0 to 999	200	250
STABILITY	0 to 999	170	80
LIFT			
Accel	0.2 TO 5.0	3	3
Decel	0.2 TO 5.0	0.5	0.5
UP MIN ENG	1400 TO 2200 RPM	2000	1800
UP MAX ENG	2600 to 3600 RPM	3600	3000
LO MAX	35 to 55%	50	50
GAIN	0 to 999	150	5
DROOP	0 to 999	220	200
STABILITY	0 to 999	125	90
IDLE			
ENGINE SPEED	1200 TO 1500 rpm	1500	1500
GAIN	0 to 999	150	10
DROOP	0 to 999	250	90
STABILITY	0 to 999	100	130
MIN ACT	0 TO 100%	19	18
MAX ACT L/D	0 TO 100%	60	100
MAX ACT IDLE	0 TO 100%	55	55
CUT ACT	200 TO 2800 RPM	500	500
GEN ENG SPD	2000 TO 3600 RPM	3000	3000

4150335B

2.22 MACHINE CONFIGURATION PROGRAMMING INFORMATION

NOTICE

TABLE 2-12 APPLIES TO MACHINES WITH SOFTWARE VERSION 13.1.

NOTE: When configuring a MRT scissors machine, the machine configuration must be completed before any personality settings can be changed. Changing the personality settings first and then changing the model number of the machine configuration will cause the personality settings to return to default values.

Table 2-12. Machine Configuration Programming Information - Software Version 13.1

CONFIGURATION DIGIT	NUMBER	DESCRIPTION	DEFAULT NUMBER
1 (Model #)	0	260 MRT	0
2 (Engine Selection)	0 1	750 Dual Fuel 905 Diesel	0
3 (Tilt Config)	0 1 2	CEW/O Cutout - Default setting for CE machines. Tilt angle is 3° side to side and 5° front to back. DOM/CSAW/CUT - Cutout lift up and drive if tilted and elevated. Required for CSA market. Tilt angle is 3° side to side and front to back. LIFT up and DRIVE - Cutout lift up and drive if tilted and elevated. Required for AUS and BRZ markets. Optional for DOM and CE markets. Tilt angle is 3° side to side and 5° front to back.	1
4 (Drive Cutout)	0 1	No drive cutout switch installed. Cuts out drive when deck is elevated above a predetermined elevation (Not available on 260MRT)	0
5 (Control Direction)	0 1	FWD & LIFT up FWD & LIFT down (for future use)	0
6 (Leveling Jacks)	0 1	No Yes	0
7 (Axle Type)	0 1 2	DOM and CE FIXED DOMESTIC OSCILLATING CE OSCILLATING	0
8 (Function Cutout)	0 1 2	NONE DRIVE and LIFT UP ALL FUNCTIONS	0
9 (Load)	0 1 2	NOT INSTALLED CUTOUT PLATFORM CUTOUT ALL	0

4150336F

NOTICE

TABLE 2-13 APPLIES TO MACHINES WITH SOFTWARE VERSION P1.13.

1. The Model and Market configuration must be completed before any Personality settings can be changed.
2. The Leveling Jacks configuration must be set to YES for standard 260MRT equipped with leveling jacks (>325PSI set / <200 PSI unset). This configuration must be set to

YES SPL LENGTH for 260MRT with optional special length jacks (>200PSI set / <50 PSI unset).

3. The Tilt Configuration setting is assigned a default based on Market selection. This configuration must be set to 6 DEG F-R SPL for special option vehicles for Australia that are capable of +/-6° chassis tilt front to rear.

Table 2-13. Machine Configuration Programming Information - Software Version P1.13

Configuration Digit	Number	Description	Market Default				
			0	1	2	3	4
(Model#)	0 1	260 MRT (Gas/LP) 260 MRT (Diesel)	0				
Market	0 1 2 3 4	ANSI ANSI EXPORT CSA CE AUSTRALIA	0				
Leveling Jacks	0 1 2	No. Yes Yes Spl Length	0				
Tilt Config	0 1 2	3 Deg F-R 5 Deg F-R 6 Deg F-R Spl	1	1	0	1	1
Tilt Cutout	0 1	No Yes	1	1	1	1	1
Load	0 1 2	No Cutout Platform Cutout All	1	1	1	1	1
Actuator option	0 1	No Yes	0				

100113688-F

2.23 PREVENTIVE MAINTENANCE AND INSPECTION SCHEDULE

The preventive maintenance and inspection checks are listed and defined in the following table. This table is divided into two basic parts, the "AREA" to be inspected and the "INTERVAL" at which the inspection is to take place. Under the "AREA" portion of the table, the various systems along with the components that make up that system are listed. The "INTERVAL" portion of the table is divided into two columns representing the various inspection time periods. The numbers listed within the interval column represent the applicable inspection code for which that component is to be checked.

The checks and services listed in this schedule are not intended to replace any local or regional regulations that may pertain to this type of equipment nor should the lists be considered as all inclusive. Variances in interval times may occur due to climate and/or conditions and depending on the location and use of the machine.

JLG Industries requires that a complete annual inspection be performed in accordance with the "Annual Machine Inspection Report" form. Forms are supplied with each new machine and are also available from JLG Customer Service. Form must be completed and returned to JLG Industries.

NOTICE

JLG INDUSTRIES REQUIRES THAT A COMPLETE ANNUAL INSPECTION BE PERFORMED IN ACCORDANCE WITH THE "ANNUAL MACHINE INSPECTION REPORT" FORM.

NOTE: *This machine requires periodic safety and maintenance inspections be a JLG Dealer. A decal located on the frame affords a place to record (stamp) inspection dates. Notify dealer if inspection is overdue.*

Go to Discount-Equipment.com to order your parts

Table 2-14. Preventive Maintenance and Safety Inspection

AREA	Inspections	
	Pre-Delivery ¹ or Frequent ² Inspection (Quarterly)	Annual ³ (Yearly) Inspection
Scissor Arms		
Scissor arms	1,2	1,2
Safety prop	1,3	1,3
Nuts, bolts, shafts, shields, bearings and locking devices	1,2	1,2
Cylinder/Pivot pins and attaching hardware	1,2	1,2
Platform Assembly		
Platform	1	1
Mandrill chain/gate, bar and latches	1,3	1,3
Extend deck and Locks	1,3	1,3
Guard rails and floor	1,2	1,2
Platform roll pins and fold down rails	1	1
Lanyard Anchorage Point	1,2,6	1,2,6
Chassis Assembly		
Wheel rim nuts	1 ⁵⁰	1 ⁵⁰
Tires	1,2	1,2
Oscillating axle and lock nut	3	3
Steer, Drive and axle components	1,2,3	1,2,3
Levelling jacks and stabilizers	3	3
Hydraulic tray, battery, engine compartment covers	1,3	1,3
Outriggers/stabilizers	3	3
Static Strap	1	1
Pot Hole Protection system	1,2,3	1,2,3
Side-Compartment Door Installation	1,3,5	1,3,5
Drive Motors	1,4,5	1,4,5
Platform Ladder	1,5	1,5
Drive Brakes	1,5	1,5
Drive Hubs	1,5	1,5
Engine Mounts	1	1
Engine Oil	3	3
Exhaust System	1,3	1,3
Sliding Wear Pads**	1,2,5,7	1,2,5,7
Fuel Tank	1,4	1,4
Function/Controls		
Control levers, switches, gauges and instruments	3,5	3,5
Detents properly lock, Control enclosure and protective boots/guards	1,3	1,3
Emergency stop switches at ground and platform	3	3
Lift, drive and speed cut-outs	3	3
Auxiliary power system	3	3
Function enable system	3	3

SECTION 2 - PROCEDURES

Table 2-14. Preventive Maintenance and Safety Inspection

AREA	Inspections	
	Pre-Delivery ¹ or Frequent ² Inspection (Quarterly)	Annual ³ (Yearly) Inspection
Brakes	1,3,9	1,3,9
Machine functions	3	3
Joystick/toggle return to neutral/off when released	1,3	1,3
Power System		
Engine Idle, Throttle and RPM	1,3,7	1,3,7
Engine Fluids: Oil	4	4
Engine Fluids: Coolant	1,4,7	1,4,7
Air Filter	1,5	1,5
Fuel Filter(s)	1,5	1,5
Exhaust System	1,3	1,3
Batteries	1,4	1,4
Battery Fluid	4	4
Battery Charger		3
Hydraulic/Electric System		
Hydraulic cylinders	2,4,5	2,4,5
Pumps, oil lines and reservoir	1,2,4	1,2,3,4
Hydraulic filter	4,5,7	4,5,7
Hydraulic tank, cap, breather and vent	3,4,5	3,4,5
Hydraulic fitting	1,4	1,4
Electrical Connections	1,2	1,2
Switches, gauges, horn and lights	3	3
Switches and controls	1,3	1,3
All hydraulic pressures	3	3
Hydraulic Fluid	4	4
General		
No unauthorized modification or additions	9	9
Paint and overall appearance	5	5
Operation and safety manual	9	9
General Structural Condition and Welds	2	2
Grease and lubrication specification	9	9
Function test of all system	9	9
Notify JLG change in machine ownership		9
ANSI and AEM handbook	9	9
Capacity Decals	9	9
All decals/placards	9	9
Annual machine inspection		9
Safety publication	9	9
All fasteners, pins, shields and covers	1,2	1,2

Table 2-14. Preventive Maintenance and Safety Inspection

AREA	Inspections	
	Pre-Delivery ¹ or Frequent ² Inspection (Quarterly)	Annual ³ (Yearly) Inspection
Footnotes:		
¹ Prior to each sale, lease, or delivery		
² In service for 3 months; Out of service for 3 months or more; Purchased used		
³ Annually, no later than 13 months from the date of the prior inspection, Includes all daily and quarterly inspections, mandated by regulating body		
⁵⁰ Indicates a 50 hour interval required to perform task after initial use of machine. This only occurs once in machine life		
** Refer to Operators Manual for machine specific instructions		
Performance Codes:		
1 - Check for proper and secure: installation, adjustment, or torque		
2 - Visual inspection for damage: (cracks, corrosion, abrasions, distortion, excessive wear, broken welds, gouges, chafing and threads showing)		
3 - Proper operation		
4 - Check for proper sealing, signs of leakage and fluid level		
5 - Clean and free of debris		
6 - Decals installed and legible		
7 - Check for proper tolerances, routing, and lubrication		
8 - Fully Charged		
9 - Verify/Perform		

 **NOTES:**

Lined area for notes, consisting of two columns of horizontal lines. A large, light blue diagonal watermark reads 'Go to Discount-Equipment.com to order your parts' across the entire page.

PARTS FINDER

**Search Website
by Part Number**



**Search Manual
Library For Parts
Manual & Lookup Part
Numbers – Purchase
or Request Quote**

Search Manuals

Enter your information to search for manuals and parts.

* Brand:

* Model:

* Serial:

* Part Number:

* Category:

SEARCH

**Can't Find Part or
Manual? Request Help
by Manufacturer,
Model & Description**

Parts Order Form

Please fill in the following information:

Manufacturer:

Model:

Description:

Quantity:

Part Number:

Part Name:

Part Category:

Part Location:

Part Condition:

Part Material:

Part Color:

Part Weight:

Part Dimensions:

Part Notes:

Submit

Discount-Equipment.com is your online resource for quality parts & equipment.

Florida: **561-964-4949** Outside Florida TOLL FREE: **877-690-3101**

Need parts?

Click on this link: <http://www.discount-equipment.com/category/5443-parts/> and choose one of the options to help get the right parts and equipment you are looking for. Please have the machine model and serial number available in order to help us get you the correct parts. If you don't find the part on the website or on one of the online manuals, please fill out the request form and one of our experienced staff members will get back to you with a quote for the right part that your machine needs.

We sell worldwide for the brands: Genie, Terex, JLG, MultiQuip, Mikasa, Essick, Whiteman, Mayco, Toro Stone, Diamond Products, Generac Magnum, Airman, Haulotte, Barreto, Power Blanket, Nifty Lift, Atlas Copco, Chicago Pneumatic, Allmand, Miller Curber, Skyjack, Lull, Skytrak, Tsurumi, Husquvarna Target, , Stow, Wacker, Sakai, Mi-T- M, Sullair, Basic, Dynapac, MBW, Weber, Bartell, Bennar Newman, Haulotte, Ditch Runner, Menegotti, Morrison, Contec, Buddy, Crown, Edco, Wyco, Bomag, Laymor, Barreto, EZ Trench, Bil-Jax, F.S. Curtis, Gehl Pavers, Heli, Honda, ICS/PowerGrit, IHI, Partner, Imer, Clipper, MMD, Koshin, Rice, CH&E, General Equipment, ,AMida, Coleman, NAC, Gradall, Square Shooter, Kent, Stanley, Tamco, Toku, Hatz, Kohler, Robin, Wisconsin, Northrock, Oztec, Toker TK, Rol-Air, Small Line, Wanco, Yanmar

SECTION 3. GENERAL ELECTRICAL INFORMATION & SCHEMATICS

3.1 GENERAL

This section contains schematics to be used for locating and correcting most of the operating problems which may develop. If a problem should develop which is not presented in this section or which is not corrected by listed corrective actions, technically qualified guidance should be obtained before proceeding with any maintenance.

3.2 MULTIMETER BASICS

A wide variety of multimeters or Volt Ohm Meters (VOM) can be used for troubleshooting your equipment. A digital meter with reasonable accuracy (within 7%) is recommended for the measurements in these procedures. This section shows diagrams of a common, digital VOM configured for several different circuit measurements. Instructions for your VOM may vary. Please consult the meter operator's manual for more information.

Grounding

"Grounding the meter" means to take the black lead (which is connected to the COM (common) or negative port) and touch it to a good path to the negative side of the voltage source.

Backprobing

To "backprobe" means to take the measurement by accessing a connector's contact on the same side as the wires, the back of the connector. Readings can be done while maintaining circuit continuity this way. If the connector is the sealed type, great care must be taken to avoid damaging the seal around the wire. It is best to use probes or probe tips specifically designed for this technique, especially on sealed connectors. Whenever possible insert probes into the side of the connector such that the test also checks both terminals of the connection. It is possible to inspect a connection within a closed connector by backprobing both sides of a connector terminal and measuring resistance. Do this after giving each wire a gentle pull to ensure the wires are still attached to the contact and contacts are seated in the connector.

Min/Max

Use of the "Min/Max" recording feature of some meters can help when taking measurements of intermittent conditions while alone. For example, you can read the voltage applied to a solenoid when it is only operational while a switch, far from the solenoid and meter, is held down.

Polarity

Finding a negative voltage or current reading when expecting a positive reading frequently means the leads are reversed. Check what reading is expected, the location of the signal and that the leads are connected to the device under test correctly. Also check that the lead on the "COM" port goes to the ground or negative side of the signal and the lead on the other port goes to the positive side of the signal.

Scale

M = Mega = 1,000,000 * (Displayed Number)

k = kilo = 1,000 * (Displayed Number)

m = milli = (Displayed Number) / 1,000

μ = micro = (Displayed Number) / 1,000,000

Example: 1.2 k Ω = 1200 Ω

Example: 50 mA = 0.05 A

Voltage Measurement

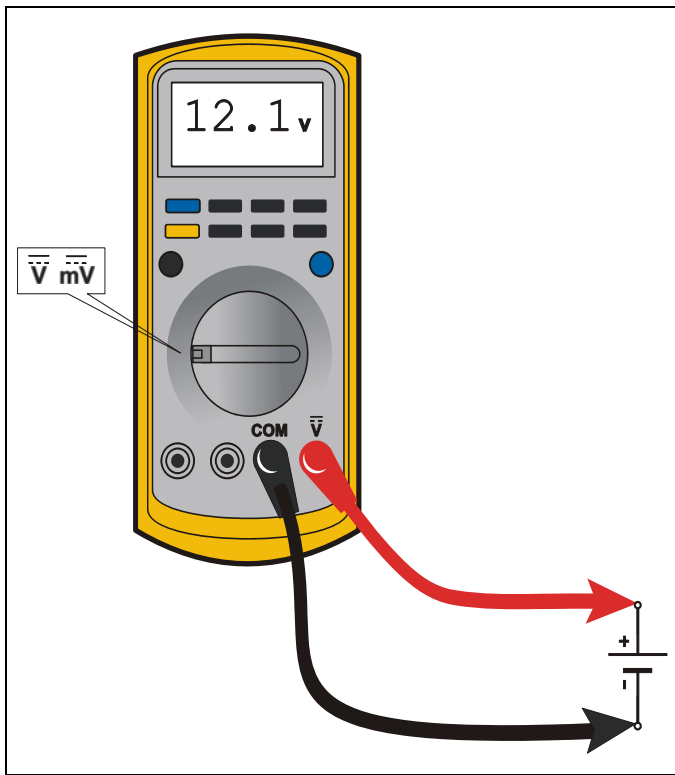

Figure 3-1. Voltage Measurement (DC)

- If meter is not auto ranging, set it to the correct range (See multimeter's operation manual)
- Use firm contact with meter leads

Resistance Measurement

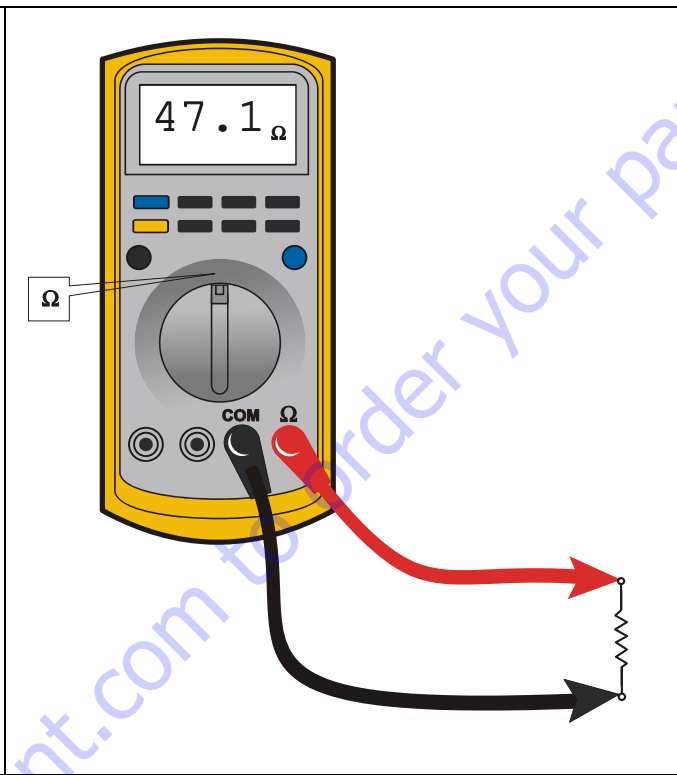
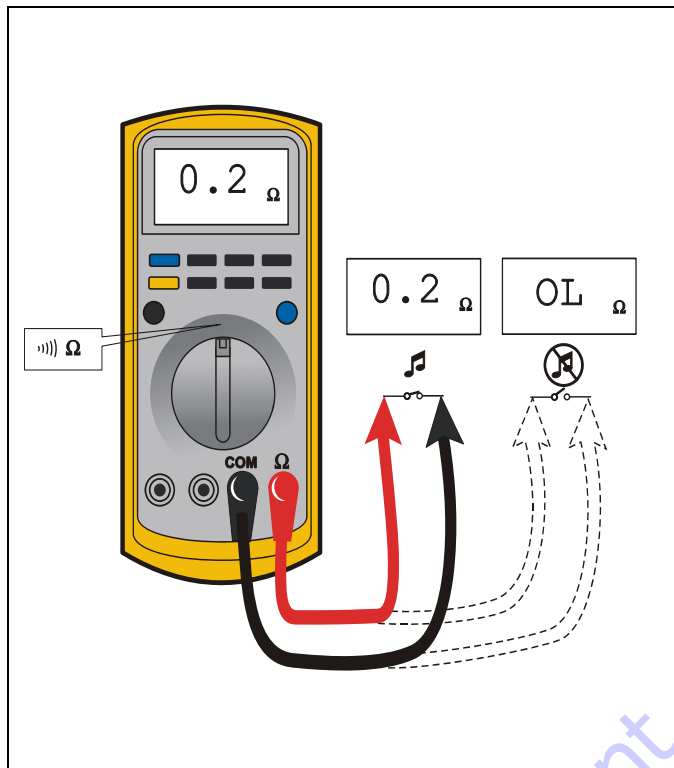
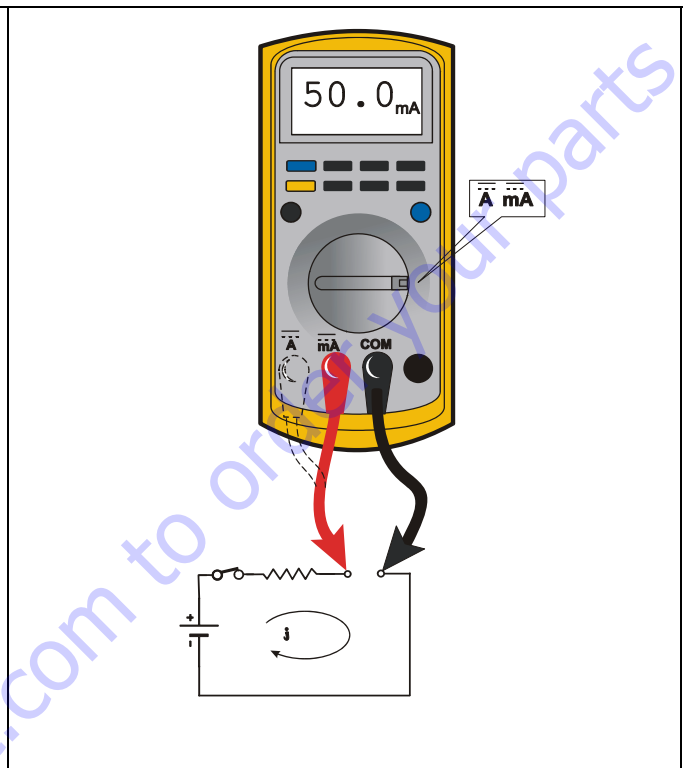

Figure 3-2. Resistance Measurement

- First test meter and leads by touching leads together. Resistance should read a short circuit (very low resistance)
- Circuit power must be turned OFF before testing resistance
- Disconnect component from circuit before testing
- If meter is not auto ranging, set it to the correct range (See multimeter's operation manual)
- Use firm contact with meter leads

Continuity Measurement**Figure 3-3. Continuity Measurement**

- Some meters require a separate button press to enable audible continuity testing
- Circuit power must be turned OFF before testing continuity
- Disconnect component from circuit before testing
- Use firm contact with meter leads
- First test meter and leads by touching leads together. Meter should produce an audible alarm, indicating continuity

Current Measurement**Figure 3-4. Current Measurement (DC)**

- Set up the meter for the expected current range
- Be sure to connect the meter leads to the correct jacks for the current range you have selected
- If meter is not auto ranging, set it to the correct range (See multi meter's operation manual)
- Use firm contact with meter leads

Continuity Measurement Over Long Distances

When trying to determine continuity of a harness or wire, longer than the reach of standard instrument leads, is possible to perform the check without excessively long leads. Using the other wires in the harness one can determine the condition of a particular wire in the harness.

Requirements:

- Harness with at least three separate wires including the wire under test.
- These wires must be able to be isolated from other wires, etc.
- Jumper or method to connect contacts on one side of harness.
- Meter that can measure resistance or continuity.

Procedure

Test multimeter leads resistance. Subtract this value from the measured resistance of the wires to get a more accurate measurement.

Consult the circuit schematic to determine which wires to use in addition to wire under test, here called wire #1 and wire #2, and how to isolate these wires. These wires should appear in the same connectors as the wire under test or are within reach of the jumper.

1. Disconnect all connections associated with the wire under test and the two additional wires. If harness is not completely isolated disconnect battery terminals also, as a precaution.
2. Measure continuity between all three wires, the wire under test, wire #1 and wire #2. These should be open. If not, repair the shorted wires or replace the harness.
3. On one side, jumper from contact of wire #1 and wire #2.
4. Measure continuity between wire #1 and wire #2. If there is continuity, both wires are good and can be used for this test. If there is not continuity, either wire could be bad. Check connections and measurement setup. Redo measurement. If still no continuity, repair wires or consult schematic for other wires to use for test.
5. Jumper from wire under test to wire #1.
6. Measure continuity. If there is continuity, the wire under test is good. Resistance of a wire increases as the length increases and as the diameter decreases.

One can find the continuity of two wires, here #1 and #2, at once by following steps 1 through 4. If there is a problem the third wire is used to troubleshoot the other wires. To find the problem, start at step 1 and use the entire procedure.

3.3 APPLYING SILICONE DIELECTRIC COMPOUND TO AMP CONNECTORS

Silicone Dielectric Compound must be used on the AMP connections for the following reasons:

- To prevent oxidation at the mechanical joint between male and female pins.
- To prevent electrical malfunction caused by low level conductivity between pins when wet.

Use the following procedure to apply Silicone Dielectric Compound to the electrical connectors.

1. To prevent oxidation and low level conductivity, silicone dielectric grease must be packed completely around male and female pins on the inside of the connector after the mating of the housing to the header. This is easily achieved by using a syringe to fill the header with silicone dielectric compound, to a point just above the top of the male pins inside the header. When assembling the housing to the header, it is possible that the housing will become air locked, thus preventing the housing latch from engaging.
2. Pierce one of the unused wire seals to allow the trapped air inside the housing to escape.
3. Install a hole plug into this and/or any unused wire seal that has silicone dielectric compound escaping from it.

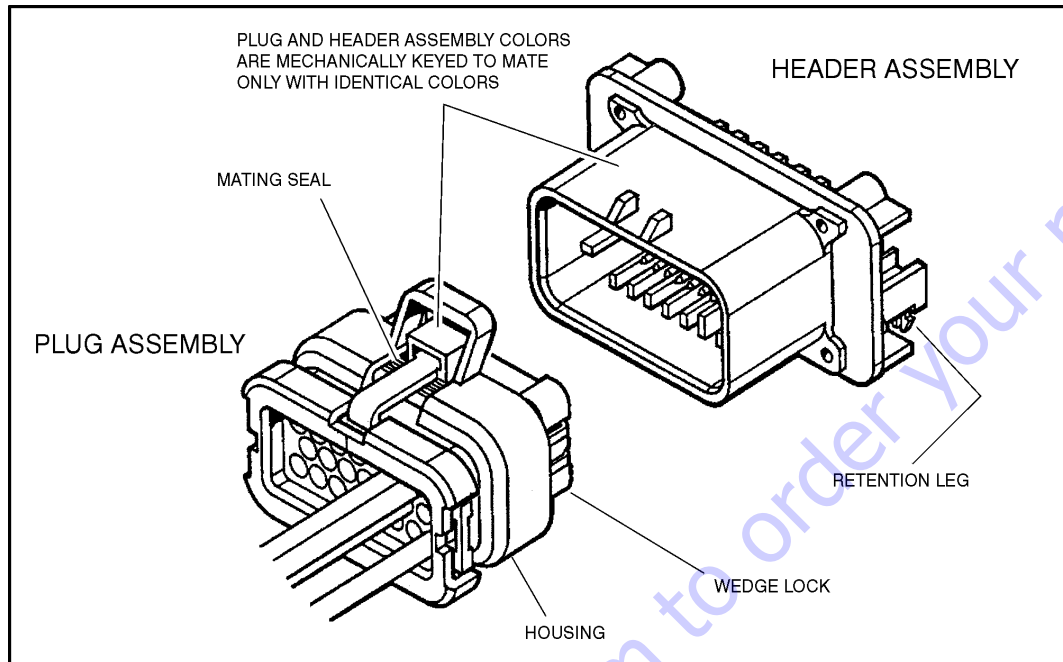

Figure 3-5. AMP Connector

Assembly

Check to be sure the wedge lock is in the open, or as-shipped, position (See Figure 3-6. Connector Assembly (1 of 4)). Proceed as follows:

1. To insert a contact, push it straight into the appropriate circuit cavity as far as it will go (See Figure 3-7. Connector Assembly (2 of 4)).
2. Pull back on the contact wire with a force of 1 or 2 lbs. to be sure the retention fingers are holding the contact (See Figure 3-7. Connector Assembly (2 of 4)).
3. After all required contacts have been inserted, the wedge lock must be closed to its locked position. Release the locking latches by squeezing them inward (See Figure 3-8. Connector Assembly (3 of 4)).
4. Slide the wedge lock into the housing until it is flush with the housing (See Figure 3-9. Connector Assembly (4 of 4)).

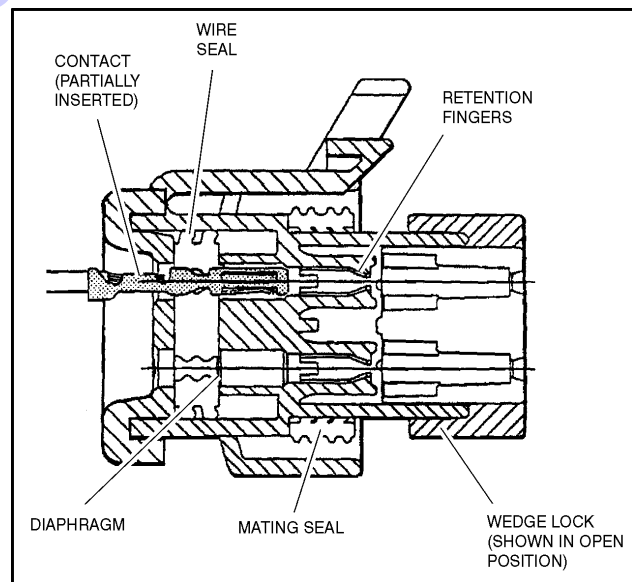

Figure 3-6. Connector Assembly (1 of 4)

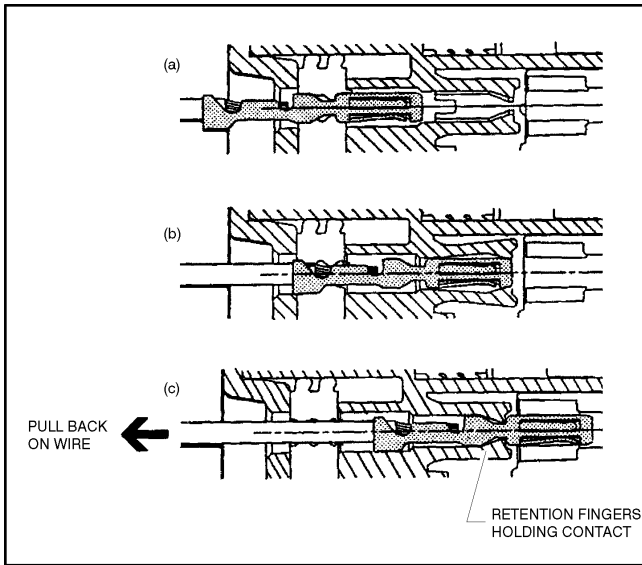

Figure 3-7. Connector Assembly (2 of 4)

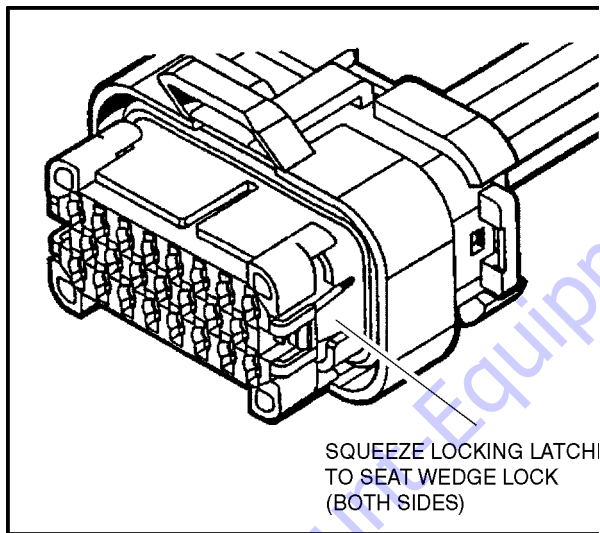

Figure 3-8. Connector Assembly (3 of 4)

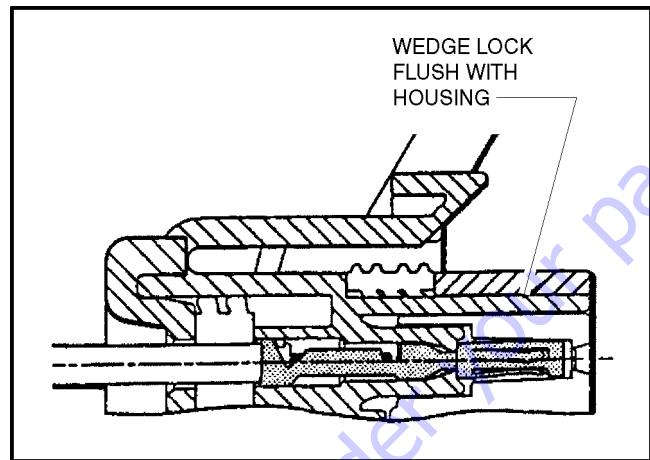

Figure 3-9. Connector Assembly (4 of 4)

Disassembly

1. Insert a 4.8 mm (3/16") wide screwdriver blade between the mating seal and one of the red wedge lock tabs.
2. Pry open the wedge lock to the open position.
3. While rotating the wire back and forth over a half turn (1/4 turn in each direction), gently pull the wire until the contact is removed.

Wedge Lock

The wedge lock has slotted openings in the forward, or mating end. These slots accommodate circuit testing in the field, by using a flat probe such as a pocket knife. DO NOT use a sharp point such as an ice pick.

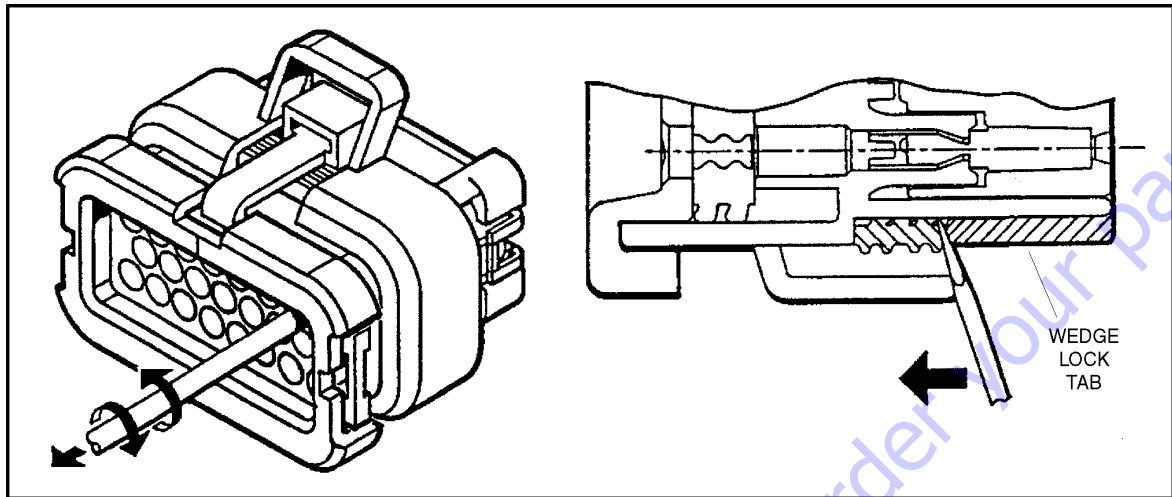

Figure 3-10. Connector Disassembly

NOTE: The wedge lock should never be removed from the housing for insertion or removal of the contacts.

Service - Voltage Reading

⚠ CAUTION

DO NOT PIERCE WIRE INSULATION TO TAKE VOLTAGE READINGS.

It has been common practice in electrical troubleshooting to probe wires by piercing the insulation with a sharp point. This practice should be discouraged when dealing with the AMPSEAL plug assembly, or any other sealed connector system. The resulting pinholes in the insulation will allow moisture to invade the system by traveling along the wire strands. This nullifies the effectiveness of the connector seals and could result in system failure.

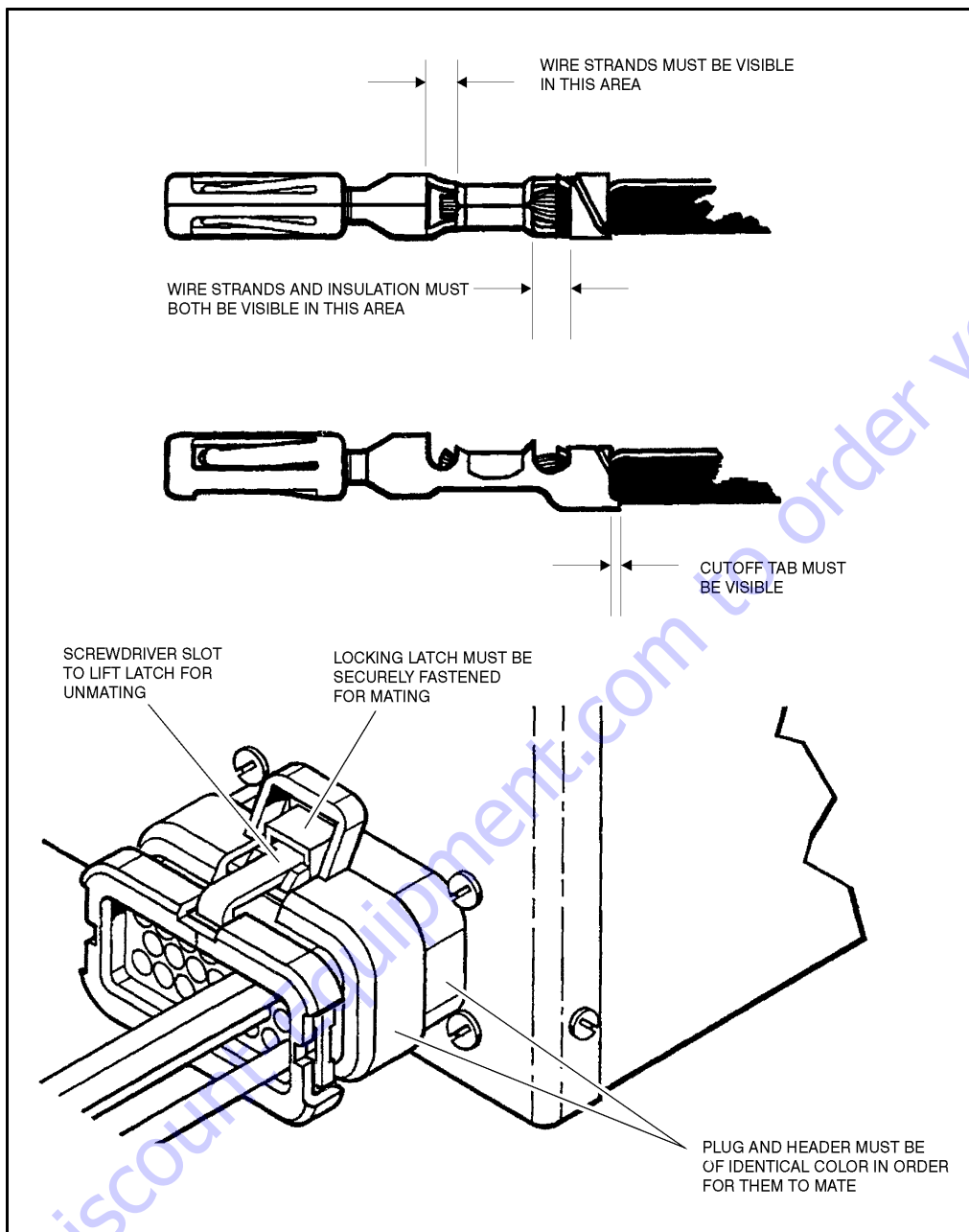

Figure 3-11. Connector Installation

3.4 WORKING WITH DEUTSCH CONNECTORS

DT/DTP Series Assembly

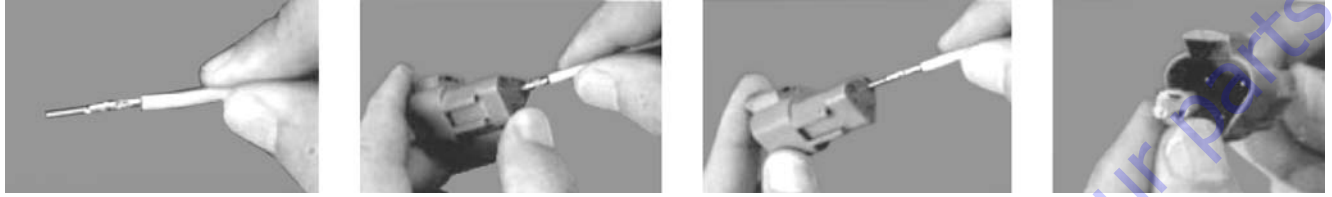

Figure 3-12. DT/DTP Contact Installation

1. Grasp crimped contact about 25mm behind the contact barrel.
2. Hold connector with rear grommet facing you.
3. Push contact straight into connector grommet until a click is felt. A slight tug will confirm that it is properly locked in place.
4. Once all contacts are in place, insert wedgelock with arrow pointing toward exterior locking mechanism. The wedgelock will snap into place. Rectangular wedges are not oriented. They may go in either way.

NOTE: The receptacle is shown - use the same procedure for plug.

DT/DTP Series Disassembly



Figure 3-13. DT/DTP Contact Removal

5. Remove wedgelock using needlenose pliers or a hook shaped wire to pull wedge straight out.
6. To remove the contacts, gently pull wire backwards, while at the same time releasing the locking finger by moving it away from the contact with a screwdriver.
7. Hold the rear seal in place, as removing the contact may displace the seal.

HD30/HDP20 Series Assembly



Figure 3-14. HD/HDP Contact Installation

8. Grasp contact about 25mm behind the contact crimp barrel.
9. Hold connector with rear grommet facing you.
10. Push contact straight into connector grommet until a positive stop is felt. A slight tug will confirm that it is properly locked in place.



Figure 3-15. HD/HDP Locking Contacts Into Position

NOTE: For unused wire cavities, insert sealing plugs for full environmental sealing

HD30/HDP20 Series Disassembly



Figure 3-16. HD/HDP Contact Removal

11. With rear insert toward you, snap appropriate size extractor tool over the wire of contact to be removed.
12. Slide tool along into the insert cavity until it engages contact and resistance is felt.
13. Pull contact-wire assembly out of connector.



Figure 3-17. HD/HDP Unlocking Contacts

NOTE: Do not twist or insert tool at an angle.

3.5 SWITCHES

Basic check

The following check determines if the switch is functioning properly, not the circuit in which the switch is placed. A switch is functioning properly when there is continuity between the correct terminals or contacts only when selected.

1. De-energize the circuit.
2. Isolate the switch from the rest of the circuit if possible. If not possible, keep in mind it may affect readings.
3. Access the terminals to the switch.
4. If the switch has two terminals:
 - a. Measure resistance across the terminals.
 - b. Change the switch position.
 - c. Measure resistance again with the leads in the same positions. If the meter was reading short, it should read an open. If the meter was reading open it should read short.
5. If the switch has more than two terminals, consult the schematic or switch diagram to determine what terminals will be connected. The test is similar to testing a switch with two terminals.
 - a. Place one meter lead on the common contact and the other on a different contact in the same circuit.
 - b. Cycle through all positions of the switch. The meter should read short only when the switch connects the two terminals and open otherwise.
 - c. If the switch has more than one common contact repeat the process for that circuit.

Limit Switches

Limit switches are used to control movement or indicate position. Mechanical limit switches are just like manually operated switches except that the moving object operates the switch. These switches can be tested the same way as a standard switch by manually operating the sensing arm.

Another type of limit switch used by JLG is the inductive proximity switch, also referred to as a "prox switch". Inductive proximity switches are actuated only by ferrous metal (metal that contains Iron, such as steel) near the switch. They do not require contact, and must be energized to actuate. These types of switches can be used to detect boom or platform position, for example. These switches have a sensing face where the switch can detect ferrous metal close to it. To find the sensing face, take note how the switch is mounted and how the mechanisms meet the switch. Test this type of switch as follows:

1. Remove prox switch from its mount.

2. Reconnect harness if it was disconnected for step a, and turn on machine.
3. Hold switch away from metal and observe switch state in the control system diagnostics using the Analyzer. See vehicle or control system documentation on how to do this.
4. Place sensing face of switch on the object to be sensed by the switch. If that is not available, use a piece of ferrous metal physically similar to it. The switch state in the control system diagnostics should change.
5. When reinstalling or replacing switch be sure to follow mounting instructions and properly set the gap between the switch and object sensed.

Automatic Switches

If the switch is actuated automatically, by temperature or pressure for example, find a way to manually actuate the switch to test it. Do this either by applying heat or pressure, for example, to the switch. These switches may need to be energized to actuate.

1. Connect instrumentation to monitor and/or control the parameter the switch is measuring.
2. Observe switch state in control system with the Analyzer. See vehicle or control system documentation on how to do this.
3. Operate system such that the switch actuates. This could be going over a certain pressure or temperature, for example. The state indicated in the control system should change.

Switch Wiring - Low Side, High Side

When controlling a load, a switch can be wired between the positive side of the power source and the load. This switch is called a "high side" switch. The switch supplies the power to the load. When a switch is wired between the negative side of the power source and the load, it is a "low side" switch. The switch provides the ground to the load.

A low side switch will allow voltage to be present on the load. No power is applied because the switch is stopping current flow. This voltage can be seen if the measurement is taken with one test lead on the load and the other on the battery negative side or grounded to the vehicle. What is actually being measured is the voltage drop across the switch. This could mislead a technician into thinking the load is receiving power but not operating. To produce an accurate picture of power or voltage applied to the load, measure voltage across the load's power terminals. Also, the technician can measure the voltage at both power terminals with respect to battery ground. The difference between those two measurements is the voltage applied to the load.

3.6 TROUBLESHOOTING

General

This section contains troubleshooting information to be used for locating and correcting most of the operating problems which may develop in the aerial platform. If a problem should develop which is not presented in this section or which is not corrected by listed corrective actions, technically qualified guidance should be obtained before proceeding with any maintenance.

Troubleshooting Information

The troubleshooting procedures applicable to the aerial platform are listed and defined in following troubleshooting tables.

Each malfunction within an individual group or system is followed by a listing of probable causes which will enable determination of the applicable remedial action. The probable causes and the remedial action should, where possible, be checked in the order listed in the tables.

It should be noted that there is no substitute for a thorough knowledge of the equipment and related systems.

It should be recognized that the majority of the problems arising in the machine will be centered in the hydraulic and electrical systems. For this reason, every effort has been made to ensure that all likely problems in these areas are given the fullest possible treatment. In the remaining machine groups, only those problems which are symptomatic of greater problems which have more than one probable cause and remedy are included. This means that problems for which the probable cause and remedy may be immediately obvious are not listed in this section.

The first rule for troubleshooting any circuit that is hydraulically operated and electrically controlled is to determine if the circuit is lacking hydraulic oil and electrical control power. This can be ascertained by overriding the bypass valve (mechanically or electrically) so that oil is available to the function valve, then overriding the function valve mechanically. If the function performs satisfactorily, the problem exists with the control circuit.

Hydraulic Circuit Checks

The first reference for improper function of a hydraulic system, where the cause is not immediately apparent, should be the Troubleshooting Chart. The best place to begin the problem analysis is at the power source (pump). Once it is determined that the pump is serviceable, then a systematic check of the circuit components, beginning with the control, would follow. For aid in troubleshooting, refer to the Illustrated Parts Manual for hydraulic diagrams of the various circuits.

Table 3-1. Elevation System Troubleshooting

TROUBLE	PROBABLE CAUSE	REMEDY
Platform Elevation System		
No Response to Lift Control		
	Lift not performed within three seconds after lift function switch is selected.	Reselect lift function switch, then activate joystick within three seconds.
	Enable circuit not functioning properly.	Replace enable circuit card.
	Lift control switch inoperative.	Repair or replace control switch.
	Hydraulic system oil low.	Replenish oil as necessary.
	Restricted or broken supply line on valve bank or pump.	Clean, repair or replace line.
	Control valve not functioning properly.	Repair or replace valve.
	Lift cylinder not functioning properly.	Repair or replace cylinder.
	Hydraulic pump not functioning properly.	Repair or replace pump.
Platform will not raise.		
	Joystick not activated within three seconds after lift switch is activated.	Activate lift switch, then activate joystick within three seconds.
	Enable circuit not functioning properly.	Replace enable circuit card.
	Load capacity exceeded. (Personnel and/or equipment on platform).	Reduce load. (Refer to capacity placard).
	Hydraulic system oil low.	Replenish oil as necessary.
	Restricted or broken hydraulic line or fitting.	Clean, repair, or replace line or fitting.
	Control valve not functioning properly.	Repair or replace valve.
	Lift cylinder not functioning properly.	Repair or replace lift cylinder.
	Engine does not respond when lift control switch is moved to up position.	Refer to Electrical System Troubleshooting - No response to control switch.
	No electrical signal being sent to lift up control valve cartridge.	Refer to Electrical System Troubleshooting - No response to control switch.
Platform will not lower		
	Joystick not activated within three sec. after lift switch is activated.	Depress lift switch, then activate controller within three seconds.
	Enable circuit not functioning properly.	Replace enable circuit card.
	No electrical signal sent to lift down control valve cartridge.	Refer to Electrical System Troubleshooting - No response to control switch.
	Lift down control valve cartridge not functioning properly.	Repair or replace lift down control valve cartridge.
	Lift cylinder not functioning properly.	Repair or replace lift cylinder.
	Engine does not respond when lift switch is moved to down position.	Refer to Electrical System Troubleshooting - No response to control switch.
	No electrical signal being sent to lift down control valve.	Refer to Electrical System Troubleshooting - No response to control switch.

SECTION 3 - GENERAL ELECTRICAL INFORMATION & SCHEMATICS

Table 3-1. Elevation System Troubleshooting

TROUBLE	PROBABLE CAUSE	REMEDY
Platform raises and lowers erratically		
	Hydraulic system oil low.	Replenish oil as necessary.
	Restricted or broken hydraulic line or fitting.	Clean, repair or replace line.
	Counterbalance valve on lift cyl. improperly adjusted or not functioning properly.	Replace valve.
	Control valve not functioning properly.	Repair or replace valve.
	Worn seals in lift cylinder.	Replace seals.
	Lift cylinder not functioning properly.	Repair or replace lift cylinder.
Platform drifts down		
	Manual lowering valve not functioning properly.	Repair or replace valve.
	Worn seals in lift cylinder.	Replace seals.
	Holding valve on lift cylinder not functioning properly.	Repair or replace valve.
High Drive does not operate below horizontal		
	Damaged wiring on limit switch.	Repair or replace wiring.
	Damaged limit switch.	Replace limit switch

Table 3-2. Chassis Troubleshooting

TROUBLE	PROBABLE CAUSE	REMEDY
Drive System		
No response to drive controller		
	Joystick not activated within three seconds after drive select switch is activated.	Activate drive select switch, then activate joystick within three seconds.
	Enable circuit not functioning properly.	Replace enable circuit card.
	Hydraulic system oil low.	Replenish oil as necessary.
	Hydraulic pump not functioning properly.	Repair or replace pump.
	Restricted or broken pump supply line.	Clean, repair or replace line.
	Drive motor not functioning properly.	Repair or replace motor.
	Damaged wiring on drive controller.	Repair or replace wiring.
	Drive controller not functioning properly.	Repair or replace controller.
	Drive brake not releasing.	Determine cause and repair or replace brake.
Machine drives erratically		
	Microcircuit on controller improperly adjusted.	Adjust microswitch on controller for proper operation.
Machine will not travel forward		
	Joystick not activated within three seconds after drive switch is activated.	Activate drive switch, then activate joystick within three seconds.
	Enable circuit not functioning properly.	Replace enable circuit card.
	Hydraulic system oil low.	Replenish oil as necessary.
	Restricted or broken hydraulic line or fitting.	Clean, repair or replace line or fitting.
	Control valve not functioning properly.	Repair or replace valve.
	Drive motor not functioning properly.	Repair or replace motor.
	Brake not functioning properly.	Repair or replace brake.
	Engine will not respond when enable switch is activated and drive controller is activated.	Refer to Electrical System Troubleshooting - No response to control switch.
	No electrical signal being sent to the drive valve cartridge.	Refer to Electrical System Troubleshooting - No response to control switch.
Machine will not travel in reverse		
	See: Machine will not travel forward.	

SECTION 3 - GENERAL ELECTRICAL INFORMATION & SCHEMATICS

Table 3-2. Chassis Troubleshooting

TROUBLE	PROBABLE CAUSE	REMEDY
High-Speed Drive function does not operate		
	Loose or damaged wiring between drive controller and High Speed switch.	Ensure proper connection of wires. Using suitable test meter, perform continuity test on wiring between switches. Repair or replace wires as necessary.
	Defective high speed control switch.	Replace high speed control switch.
	Loose or damaged wiring in control box wire harness.	Ensure proper connection of wires at the control switch. Using suitable test meter, perform continuity test on wires. Repair or replace harness as necessary.
	Loose or damaged wiring between platform and high speed solenoid.	Ensure proper connection of wires at the platform and at the high speed solenoid. Using suitable test meter, perform continuity test on wires. Repair or replace wires as necessary.
	High speed solenoid not functioning properly.	Replace solenoid.
	Loose or damaged wiring between high speed relay and high speed limit switch.	Ensure proper connection of wires between high speed relay and high speed limit switch. Using suitable test meter, perform continuity test on wires. Repair or replace wires as necessary.
	High speed limit switch not functioning properly.	Repair or replace limit switch.
	Loose or damaged wiring in valve wiring harness.	Ensure proper connection of wires at terminal strip. Using suitable test meter, perform continuity test on wires. Repair or replace wires as necessary.
Steering System		
No response to steer control switch on controller		
	Steer switch on controller not functioning properly.	Repair or replace switch.
	Hydraulic system oil low.	Replenish oil as necessary.
	Hydraulic system pressure too low.	Adjust pressure.
	Loose or damaged wiring on control switch or solenoid valve.	Ensure proper connection of wires at control switch or solenoid valve. Using suitable test meter, perform continuity test on wires. Repair or replace wires as necessary.
	Restricted or broken hydraulic line on valve bank or hydraulic pump.	Clean, repair or replace line.
	Control valve not functioning properly.	Repair or replace valve.
	Steer cylinder not functioning properly.	Repair or replace cylinder.
Machine hard to steer or steering is erratic		
	Hydraulic system oil low.	Replenish oil as necessary.
	Restricted or broken hydraulic line or fitting.	Clean, repair or replace line or fitting.
Machine hard to steer or steering is erratic (cont.)		
	Lack of lubrication on steer components.	Lubricate steer components in accordance with Lubrication Chart.
	Restricted crossover relief valve.	Clean or replace valve.
	Steer system pressure low.	Adjust pressure.
	Bent steering linkage.	Repair or replace linkage as required.
	Hydraulic pump not functioning properly.	Repair or replace valve.
	Steer cylinder not functioning properly.	Repair or replace cylinder.

Table 3-2. Chassis Troubleshooting

TROUBLE	PROBABLE CAUSE	REMEDY
Steering inoperative		
	Steer switch on controller not functioning properly.	Repair or replace switch.
	Hydraulic system pressure too low.	Adjust pressure.
	Loose or damaged wiring on control switch or solenoid valve.	Ensure proper connection of wires at control switch or solenoid valve. Using suitable test meter, perform continuity test on wires. Repair or replace wires as necessary.
	Solenoid valve not functioning properly.	Repair or replace valve.
	Restricted or broken hydraulic line on valve bank or hydraulic pump.	Clean, repair or replace line.
	Relief valve improperly set or not functioning properly.	Reset, repair or replace valve as necessary.
	Steer cylinder not functioning properly.	Repair or replace cylinder.
Machine will not steer left or right		
	Steer switch on controller not functioning properly.	Replace controller.
	Wiring on steer control switch is damaged.	Repair or replace wiring.
	Wiring on solenoid valve damaged.	Repair or replace wiring.
	Coil in solenoid damaged.	Replace coil.
	Bent cylinder rod.	Repair or replace cylinder.
	Damaged steer linkage.	Repair or replace steer linkage.
Machine wanders; steering not firm		
	Crossover relief valve set too low or not functioning properly.	Reset, repair or replace valve as necessary.
	Steer linkage loose.	Tighten linkage.
	Spindle bushings badly worn.	Replace bushings.

SECTION 3 - GENERAL ELECTRICAL INFORMATION & SCHEMATICS

Table 3-3. Hydraulic System Troubleshooting

TROUBLE	PROBABLE CAUSE	REMEDY
Hydraulic System - General		
Hydraulic Pump Noisy		
	Air bubbles in oil. (Reservoir too low.)	Replenish oil as necessary.
	Oil filter dirty.	Clean and/or replace filter as necessary.
Pump cavitating. (Vacuum in pump due to oil starvation)		
	Oil in reservoir low.	Replenish Oil as necessary.
	Restricted reservoir air vent.	Clean vent.
	Oil viscosity too high.	Drain system and replace with recommended oil. Refer to Hydraulic Oil.
System overheating		
	Oil viscosity too high.	Drain system and replace with recommended oil. Refer to Hydraulic Oil.
	Main relief valve set too high.	Adjust relief valve to proper pressure.
	Hydraulic system oil low.	Replenish oil as necessary.
Pump not delivering oil		
	Defective pump.	Repair or replace pump.
System pressure too low		
	Main relief valve set too low.	Reset valve as required
	Hydraulic pump not functioning properly.	Repair or replace pump.
	Leak in component, line or fitting.	Repair or replace component, line or fitting.
	Scored valve spool; scored cylinder.	Replace valve; replace cylinder.
System(s) operate erratically		
	Sticking or binding valve cartridge, piston rod, etc.	Clean, repair or replace components as necessary
	Hydraulic oil not at operating temperature.	Allow oil sufficient time to warm up.

Table 3-4. Electrical System Troubleshooting

TROUBLE	PROBABLE CAUSE	REMEDY
Hand Controller		
Valve will not function when handle is moved in either direction.		
	Enable switch not activated.	Activate enable switch.
	Controller not activated within three seconds after enable switch is activated.	Activate enable switch, then activate controller within three seconds.
	Enable circuit not functioning properly.	Replace enable circuit card.
	No electrical power to handle.	Check electrical input to hand controller (12 Volts).
	No electrical power to valve.	Check electrical output of printed circuit board and electrical signal at the valve.
	Improper ground.	Check for proper grounding of handle.
Control Switches		
No response to a function control switch		
	Enable switch not activated.	Activate enable switch.
	Control switch not activated within three seconds after enable switch is activated.	Activate enable switch, then activate control switch within three seconds.
	Enable circuit not functioning properly.	Replace enable circuit card.
	Applicable emergency stop switch not positioned properly.	Place applicable emergency stop switch to on.
	Power selector switch on ground control box not positioned properly.	Place power selector switch to platform or ground, as required.
	Circuit breaker open.	Determine and correct cause. Reset circuit breaker.
	No voltage present at emergency stop switch.	Check battery cable from battery to emergency stop switch for proper connection or damage. Repair or replace cable as necessary.
	EMERGENCY STOP switch not functioning properly.	Replace switch.
	No voltage supplied to engine start relay from emergency stop switch.	Check battery cable from emergency stop switch to start relay for proper connection or damage. Repair or replace cable as necessary.
	No voltage input at terminal strip.	Check wire from battery to terminal strip for proper connection or damage. Repair or replace wire as necessary.
	No voltage present at circuit breaker.	Check wire from terminal strip to circuit breaker for proper connection or damage. Repair or replace wire as necessary.
	Defective circuit breaker.	Replace circuit breaker.
	No voltage present at function control switch.	Check wiring from emergency stop switch to function control switch for proper connection or damage. Repair or replace wiring as necessary.
	Defective function control switch.	Replace function control switch.

SECTION 3 - GENERAL ELECTRICAL INFORMATION & SCHEMATICS

Table 3-4. Electrical System Troubleshooting

TROUBLE	PROBABLE CAUSE	REMEDY
No response to a function control switch (cont.)		
	No voltage present at applicable control valve coil.	Check applicable wire for proper connection at terminal strip, valve harness plug pin, valve harness receptacle pin and engine start relay. Using suitable test meter, perform continuity test on wire. Repair or replace wire or harness as necessary.
	No voltage supplied from terminal strip to engine start relay.	Check applicable wire for proper connection at terminal strip, valve harness plug pin, valve harness receptacle pin and engine start relay. Using suitable test meter, perform continuity test on wire. Repair or replace wire or harness as necessary.
	Defective engine start relay.	Replace engine start relay.
	No voltage supplied to engine from start relay.	Check battery cable from relay to engine for proper connection or damage. Repair or replace cable as necessary.
	No voltage present at applicable control valve coil.	Check applicable wire for proper connection at terminal strip, valve harness plug pin, valve harness receptacle pin and valve coil. Using suitable test meter, perform continuity check on wires. Repair or replace harness as necessary.
	NO TERMINAL STRIPS!!!!!! No voltage supplied from terminal strip to electric motor start relay.	Check applicable wire for proper connection at terminal strip, valve harness plug pin, valve harness receptacle pin and electric motor start relay. Using suitable test meter, perform continuity test on wire. Repair or replace wire as necessary.
	Defective electric motor start relay.	Replace electric motor start relay.
	No voltage supplied to motor from start relay.	Check battery cable from relay to motor for proper connection or damage. Repair or replace wire as necessary.
	Defective motor/pump assembly.	Replace motor/pump assembly.

This page left blank intentionally

Go to Discount-Equipment.com to order your parts

3.7 ELECTRICAL SCHEMATICS

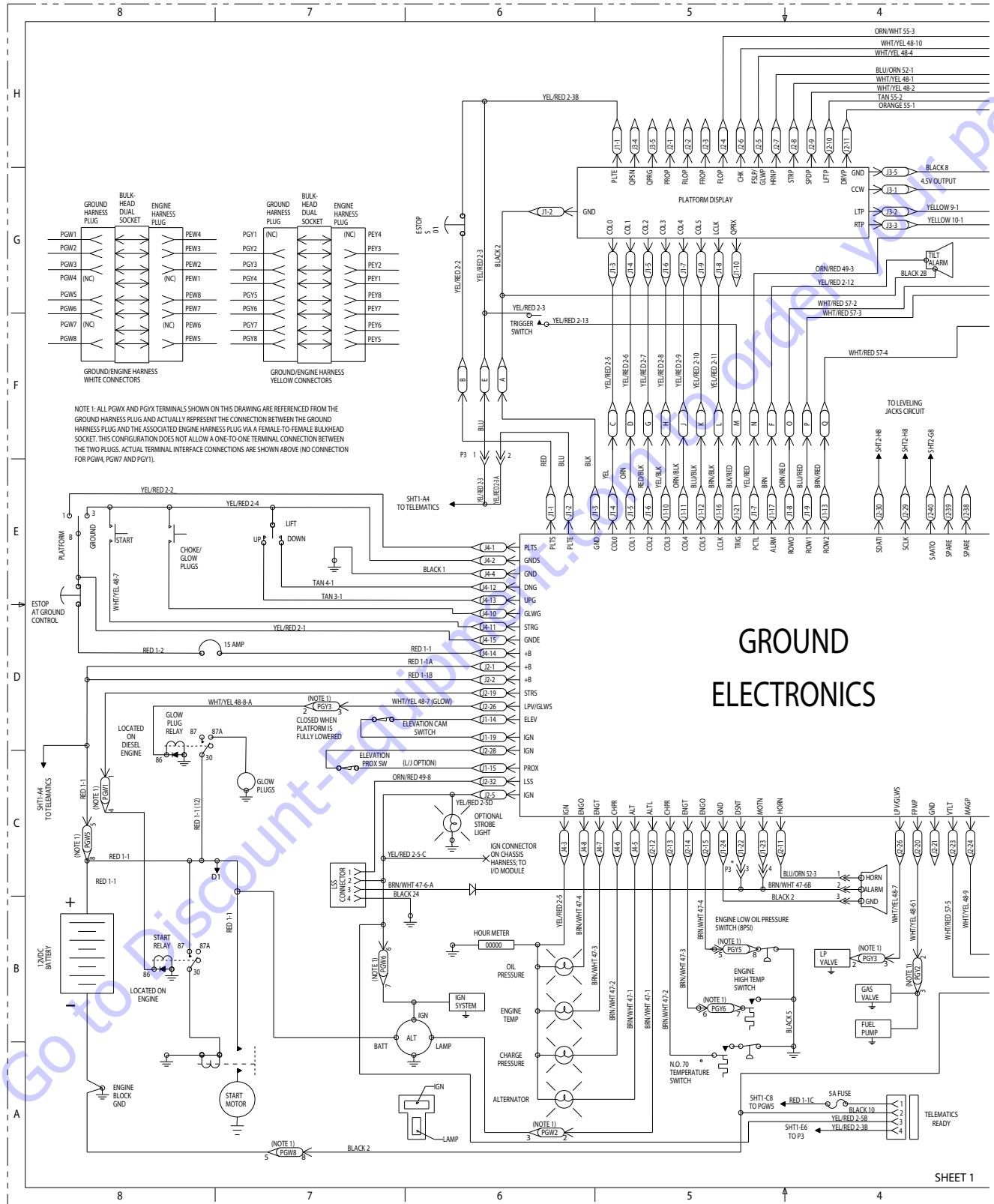

Figure 3-18. Electrical Schematic - Sheet 1 of 4

SECTION 3 - GENERAL ELECTRICAL INFORMATION & SCHEMATICS

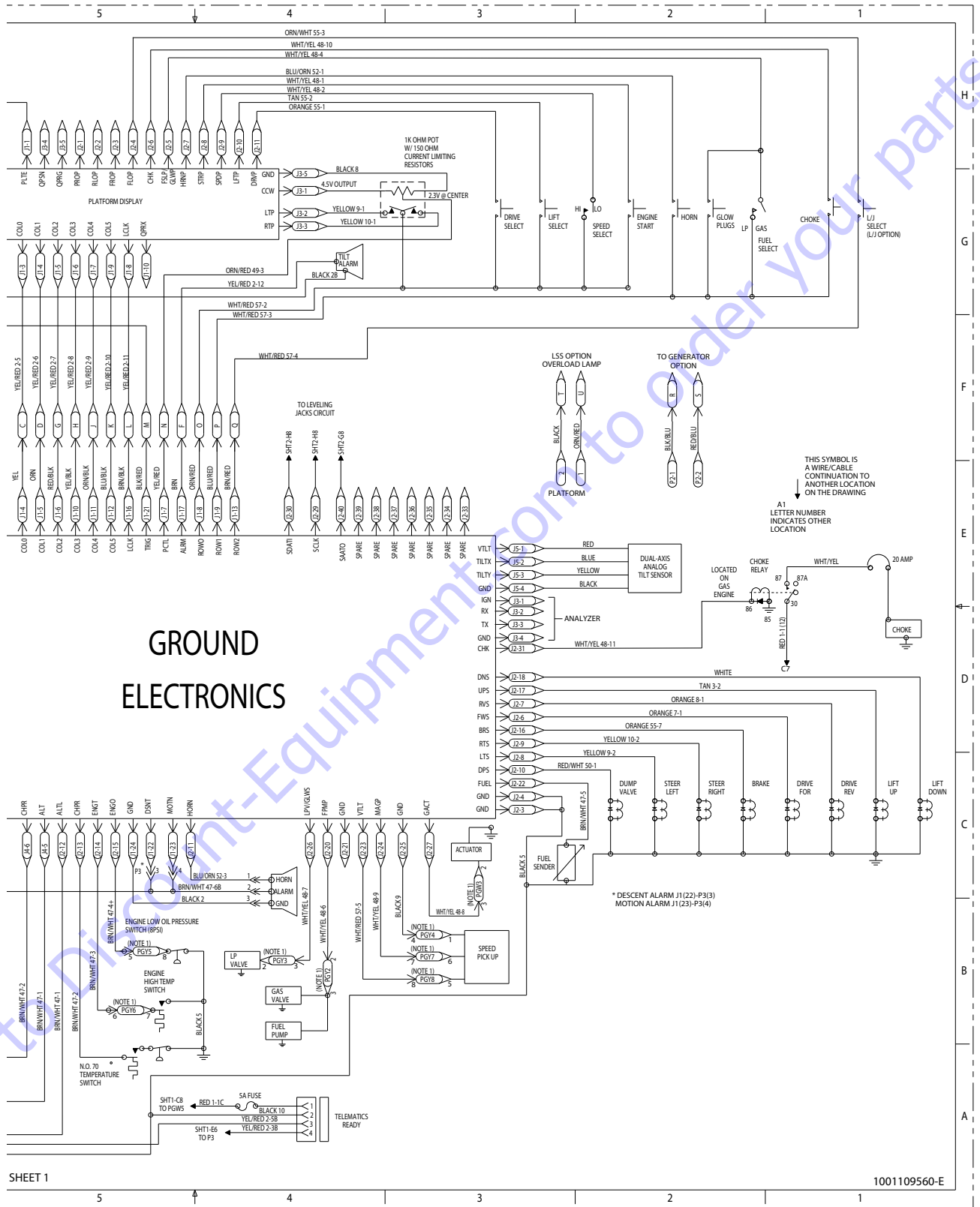

Figure 3-19. Electrical Schematic - Sheet 2 of 4

MAF03530

SECTION 3 - GENERAL ELECTRICAL INFORMATION & SCHEMATICS

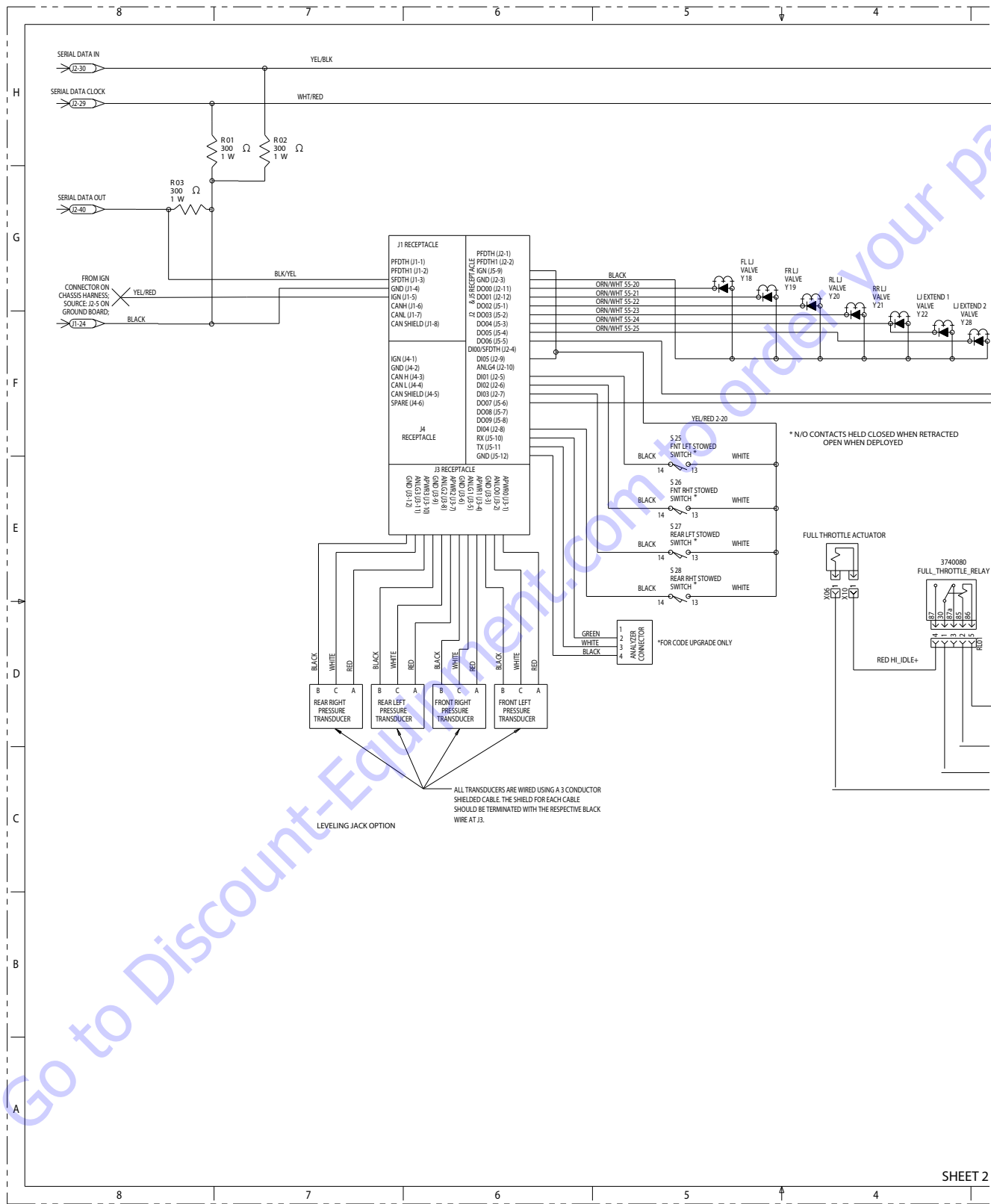
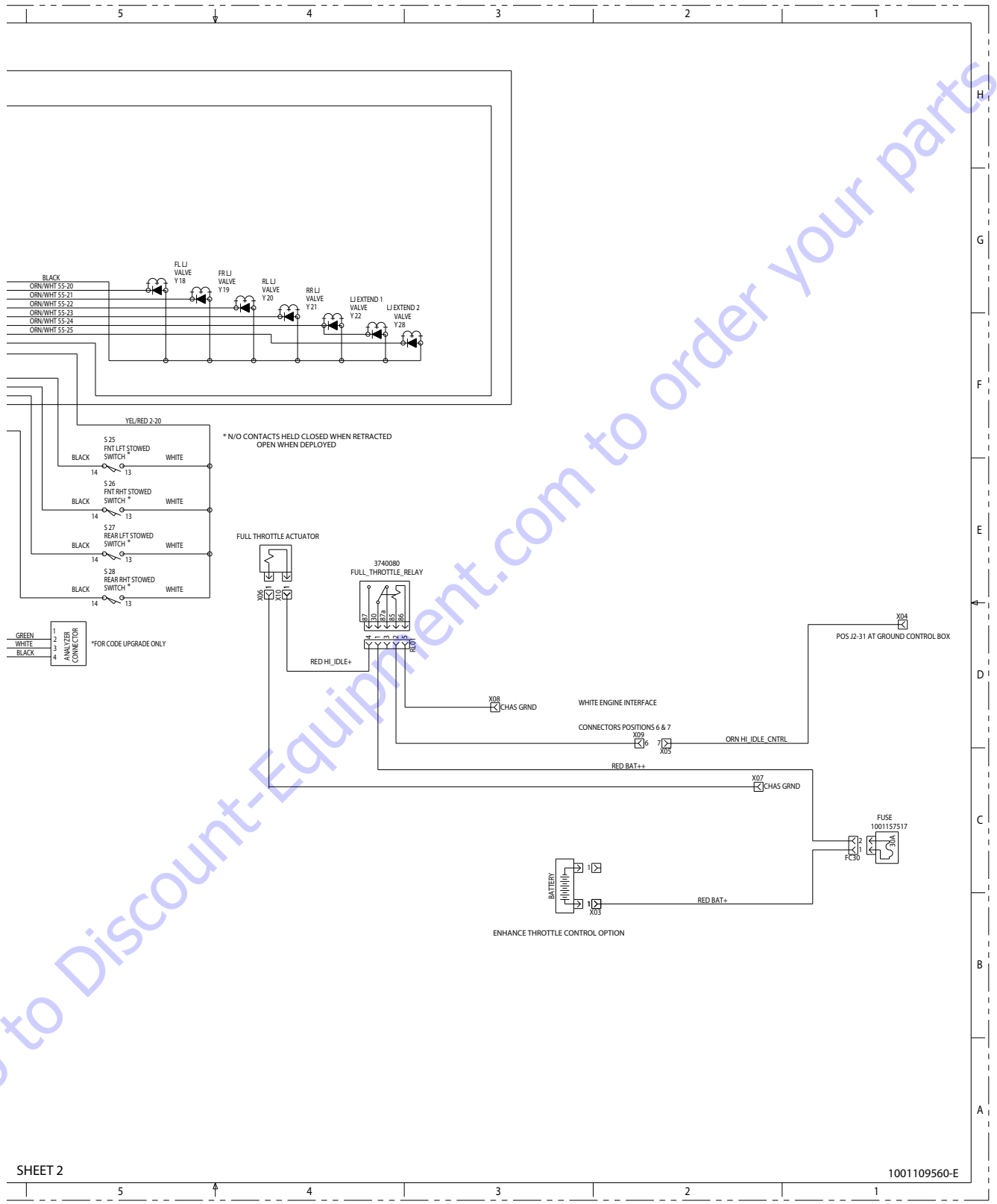

Figure 3-20. Electrical Schematic - Sheet 3 of 4

SECTION 3 - GENERAL ELECTRICAL INFORMATION & SCHEMATICS



SHEET 2

1001109560-E

Figure 3-21. Electrical Schematic - Sheet 4 of 4

MAF03500

SECTION 3 - GENERAL ELECTRICAL INFORMATION & SCHEMATICS

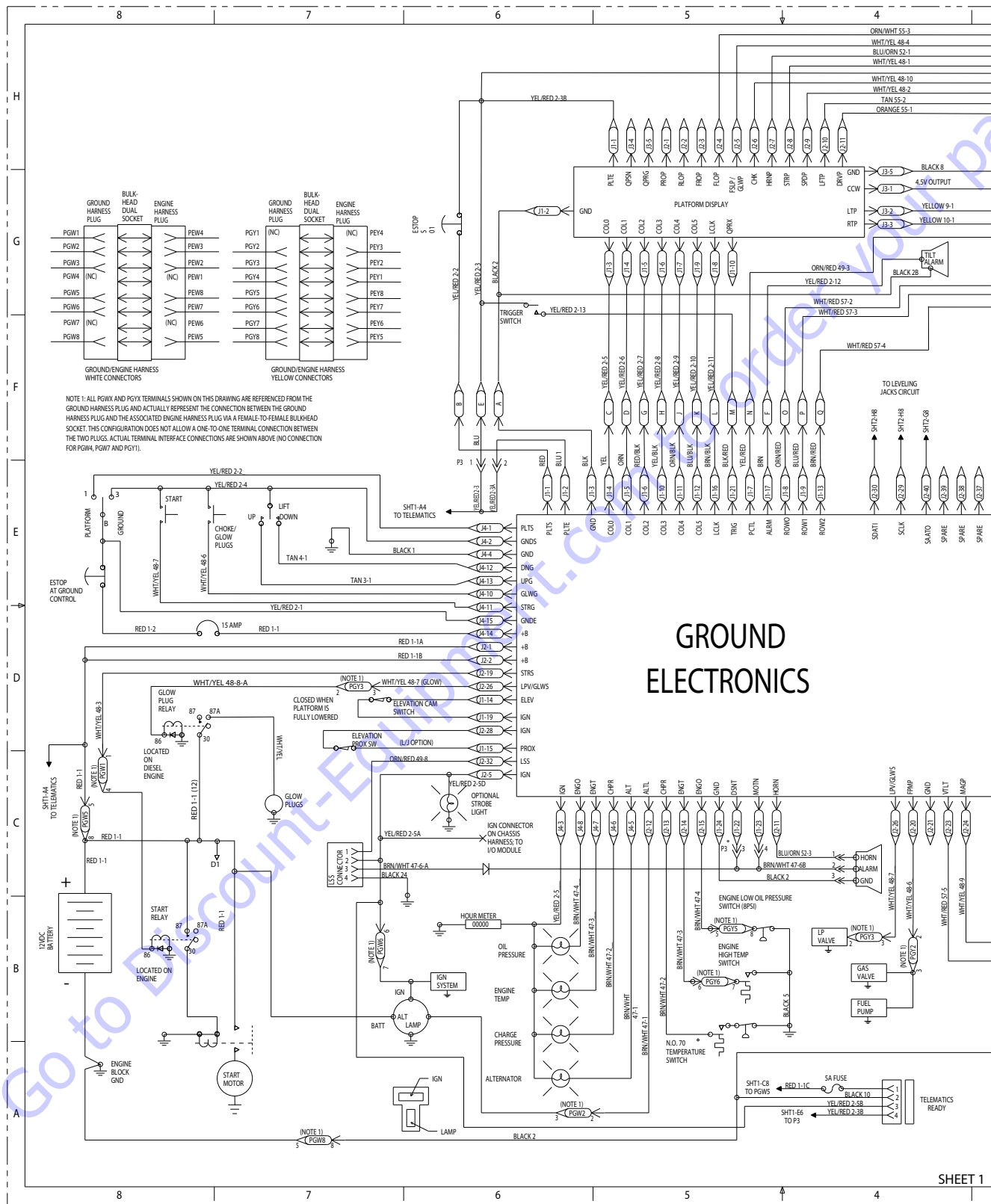

Figure 3-22. Electrical Schematic - (Generator) - Sheet 1 of 4

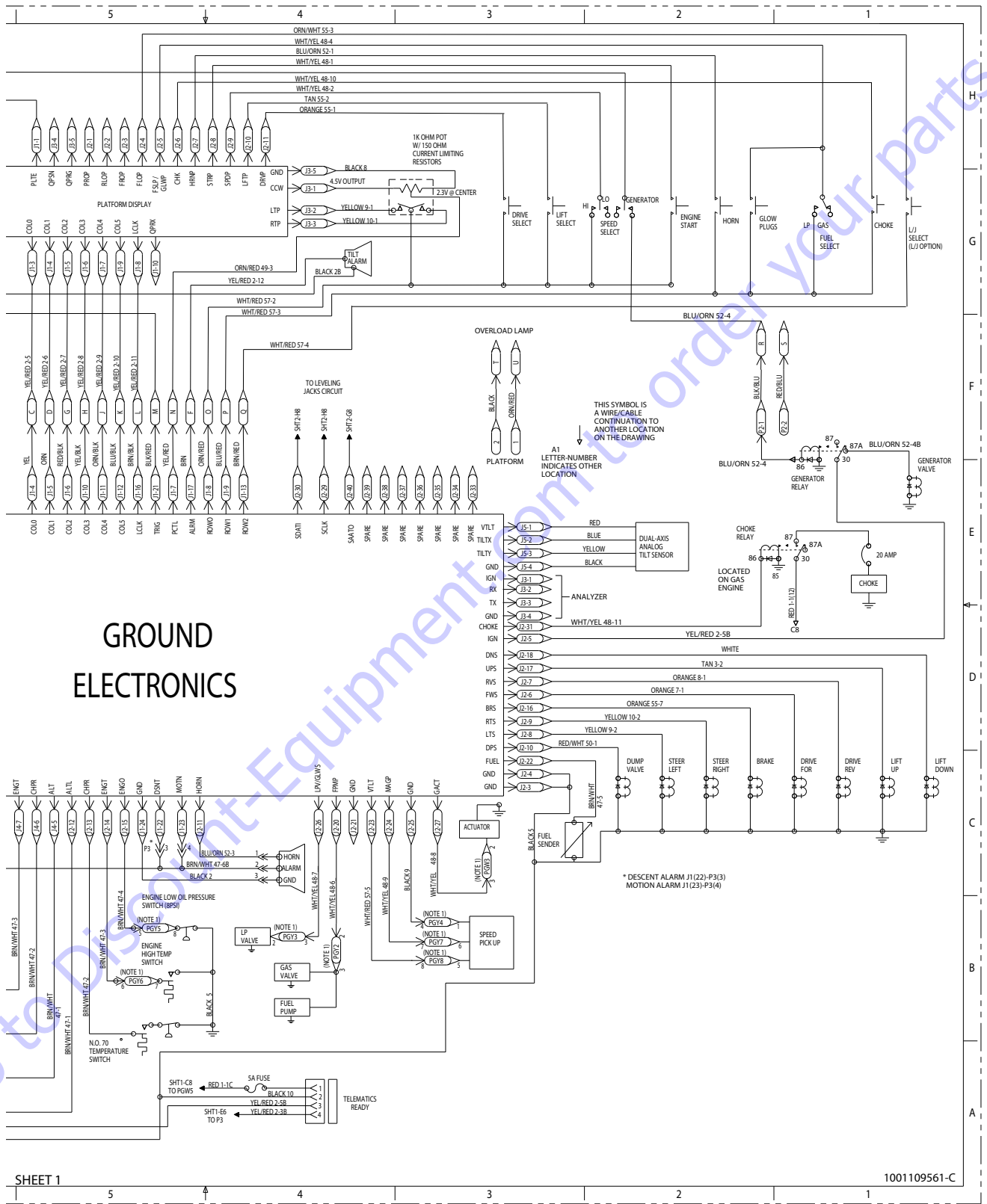

Figure 3-23. Electrical Schematic - (Generator) - Sheet 2 of 4

SECTION 3 - GENERAL ELECTRICAL INFORMATION & SCHEMATICS

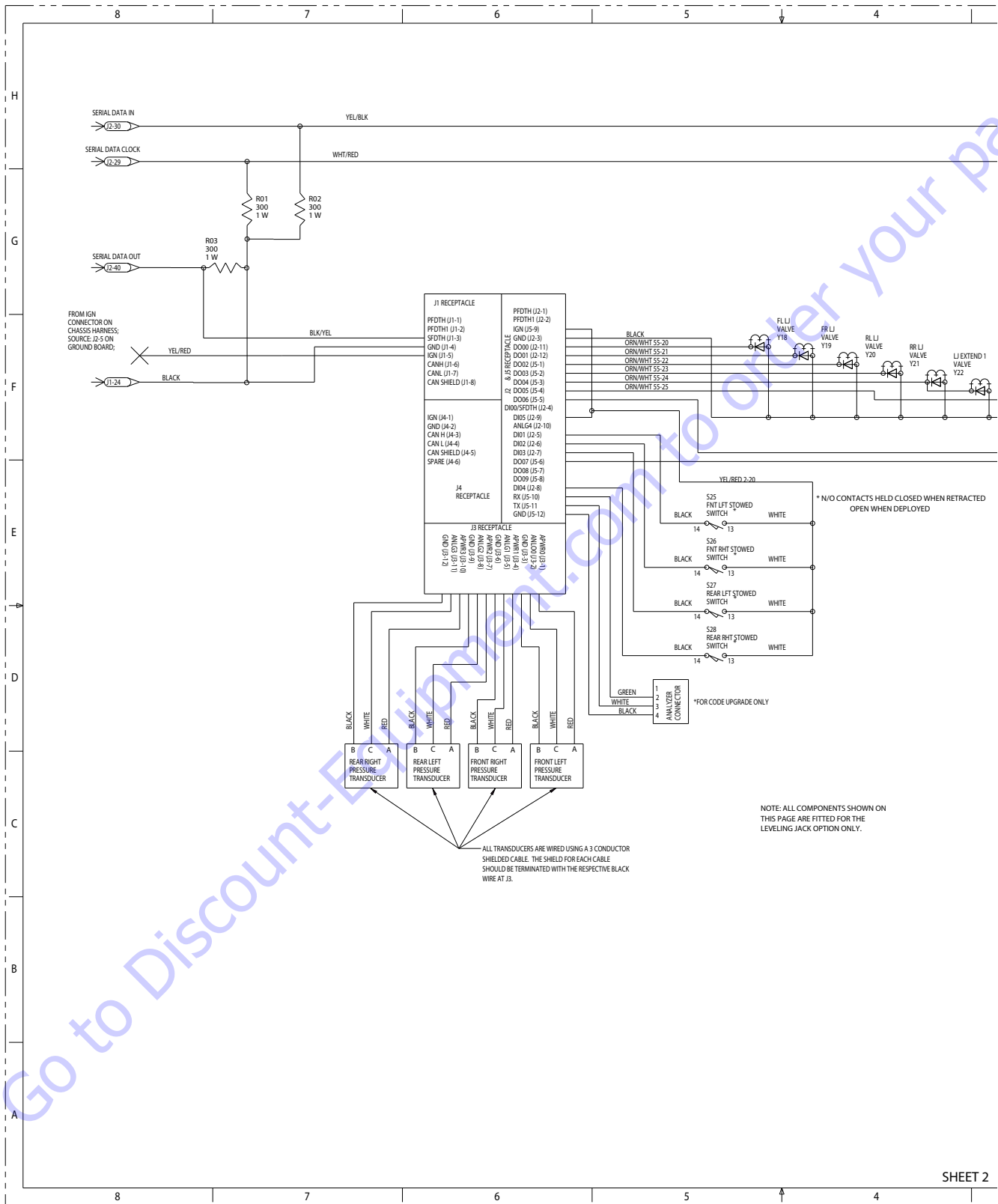

Figure 3-24. Electrical Schematic - (Generator) - Sheet 3 of 4

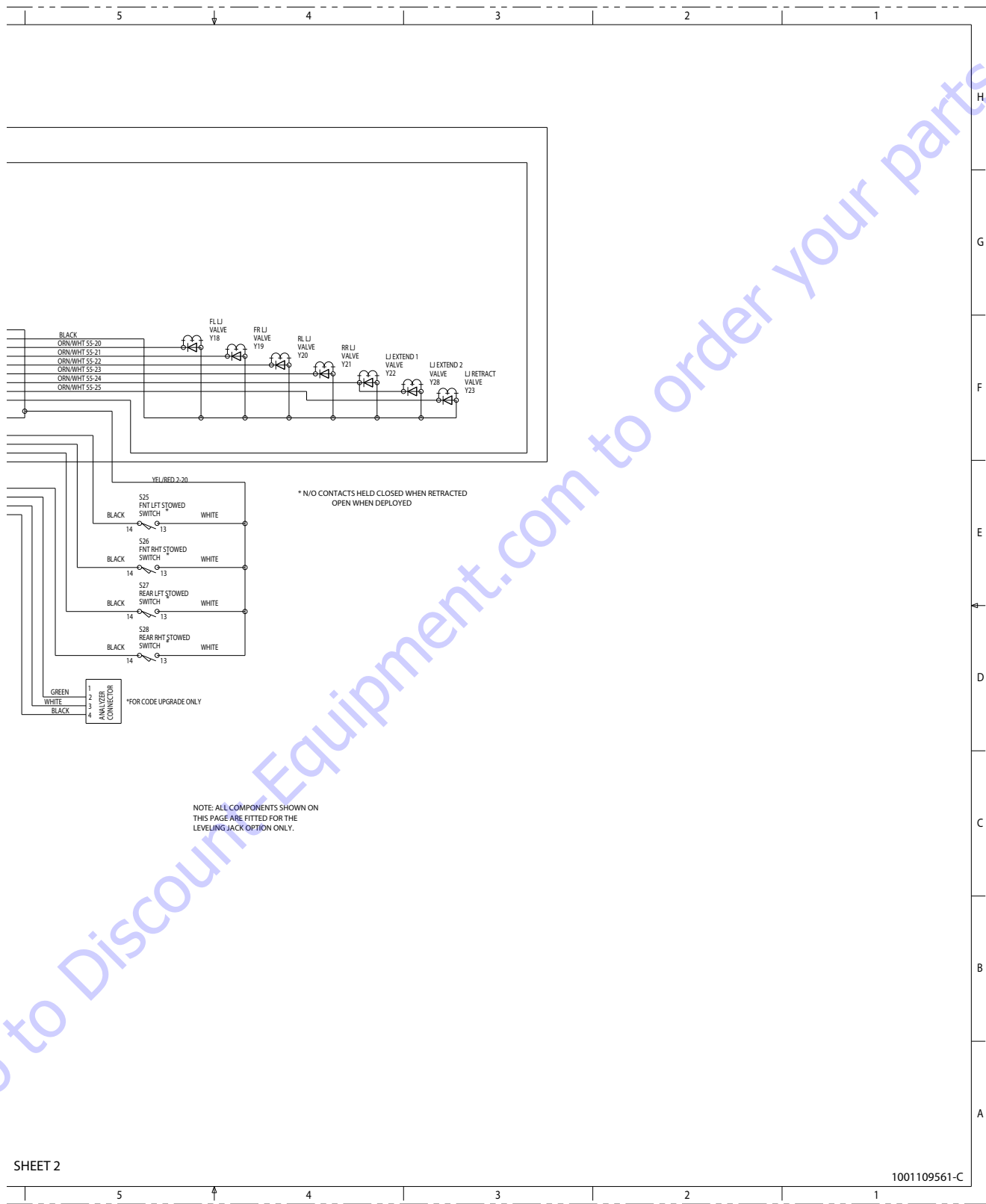

Figure 3-25. Electrical Schematic - (Generator) - Sheet 4 of 4

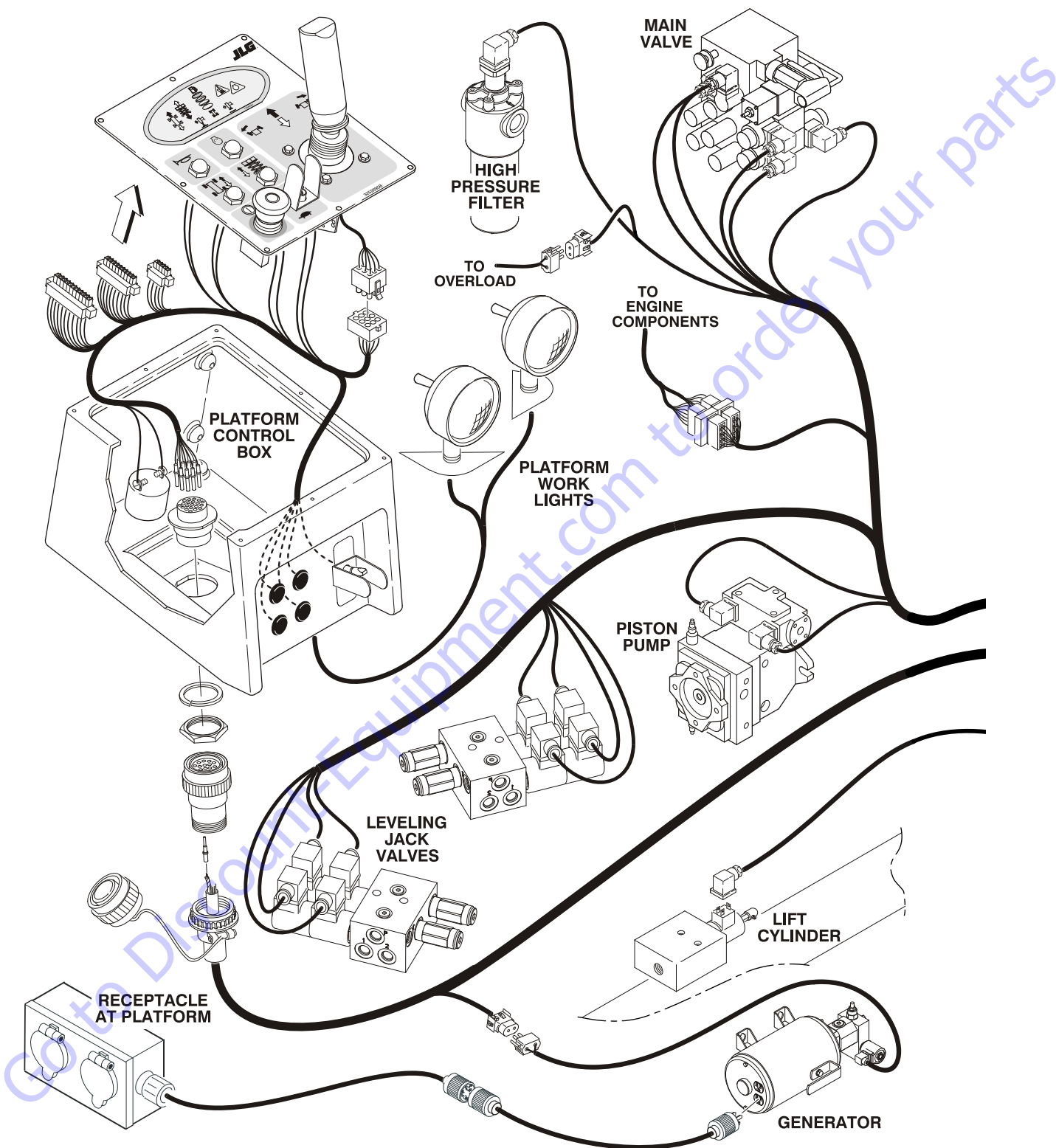

Figure 3-26. Electrical Components Installation - Prior to S/N 141689 - Sheet 1

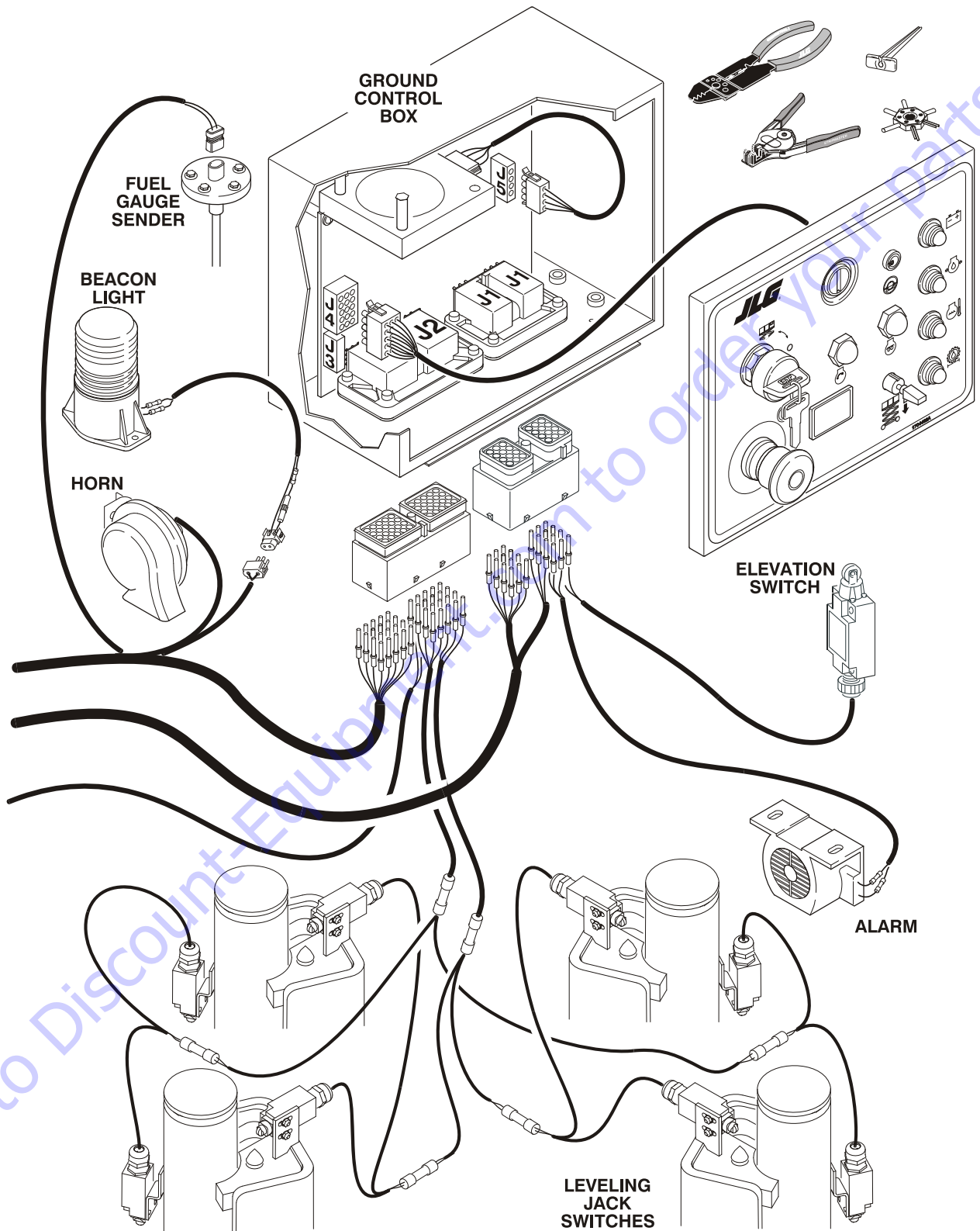

Figure 3-27. Electrical Components Installation - Prior to S/N 141689 - Sheet 2

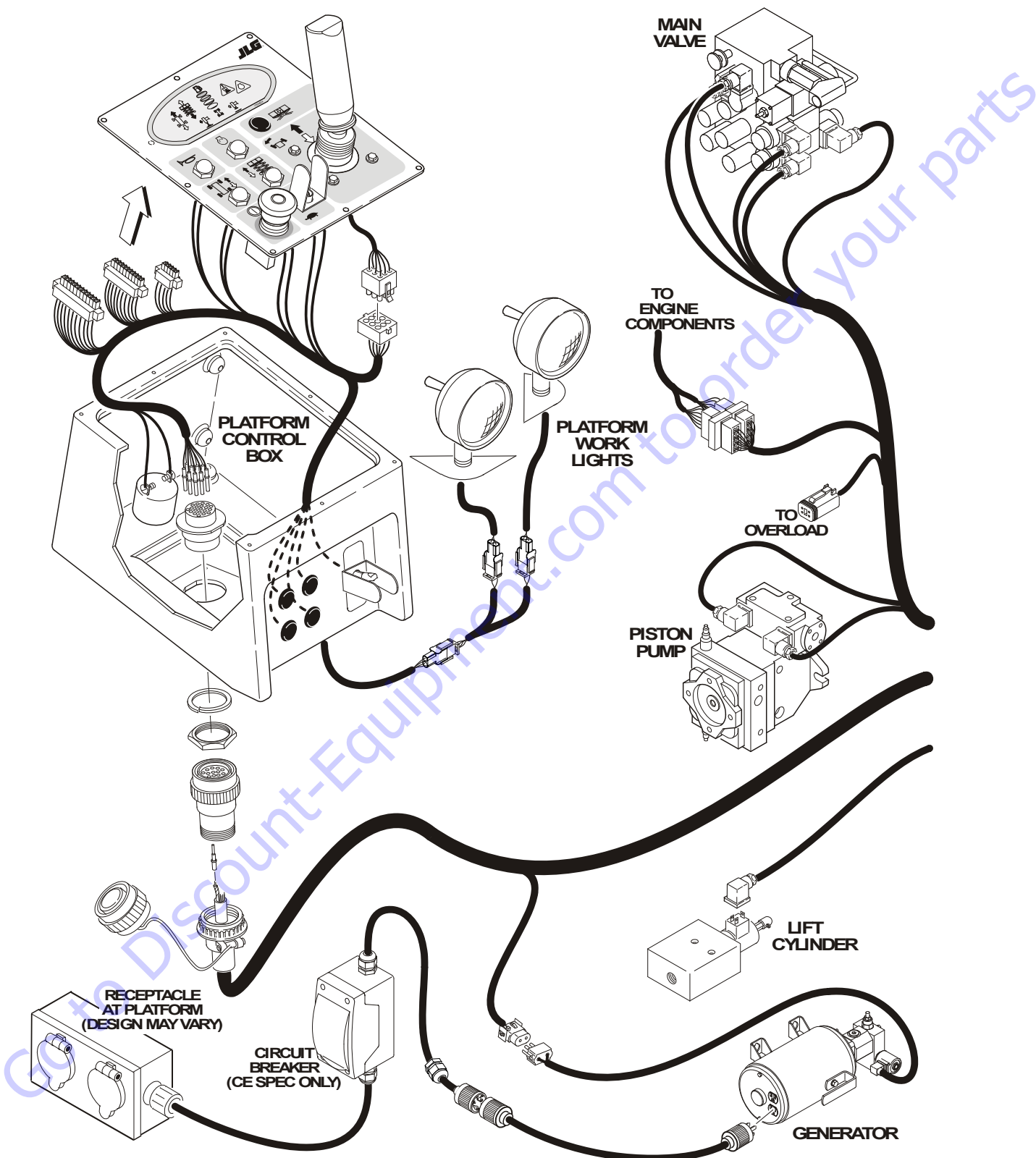

Figure 3-28. Electrical Components Installation - S/N 141689 to Present - Sheet 1

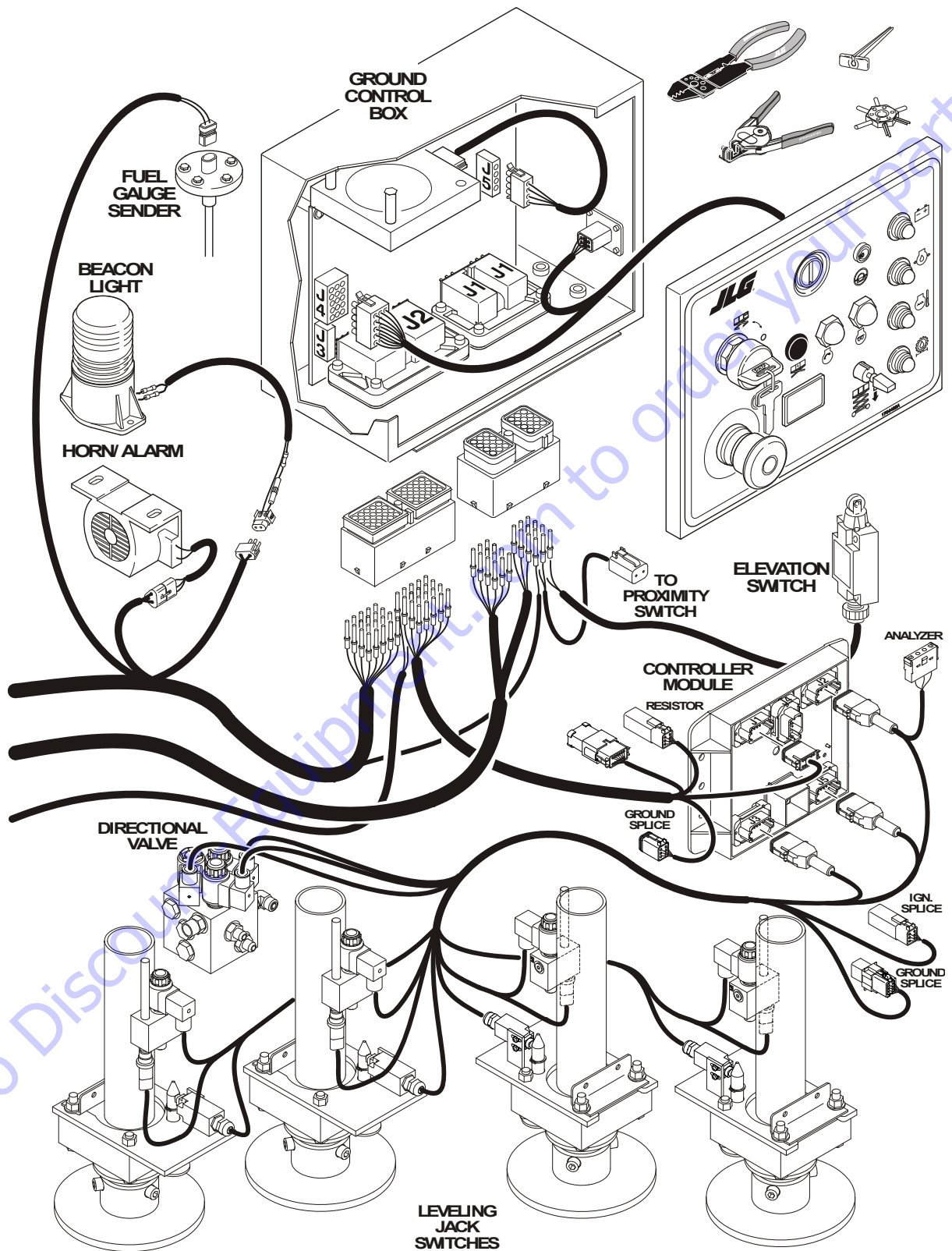

Figure 3-29. Electrical Components Installation - S/N 141689 to Present - Sheet 2

2792402 T

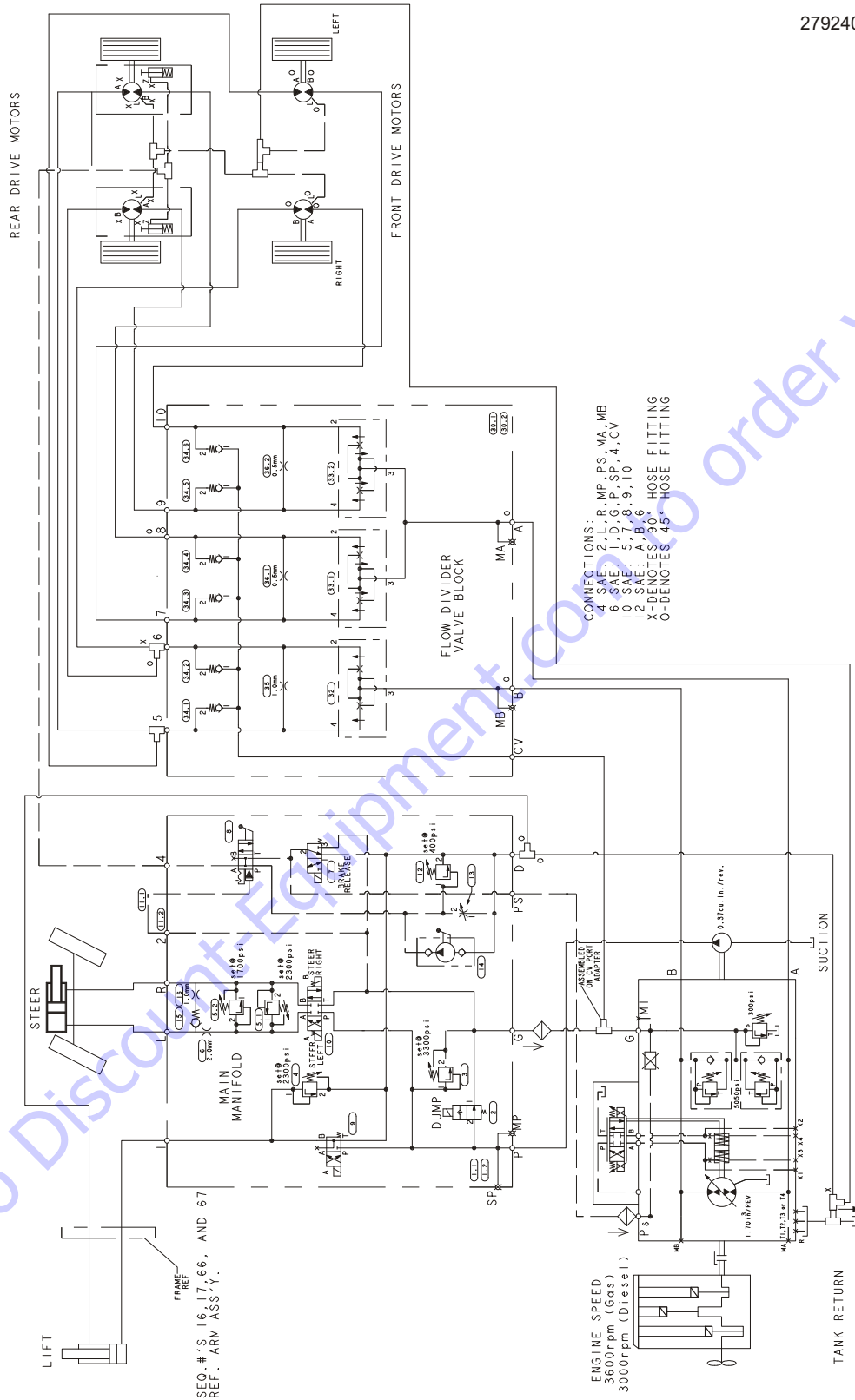

Figure 3-30. Hydraulic Schematic - Prior to S/N 141689

2792717 D

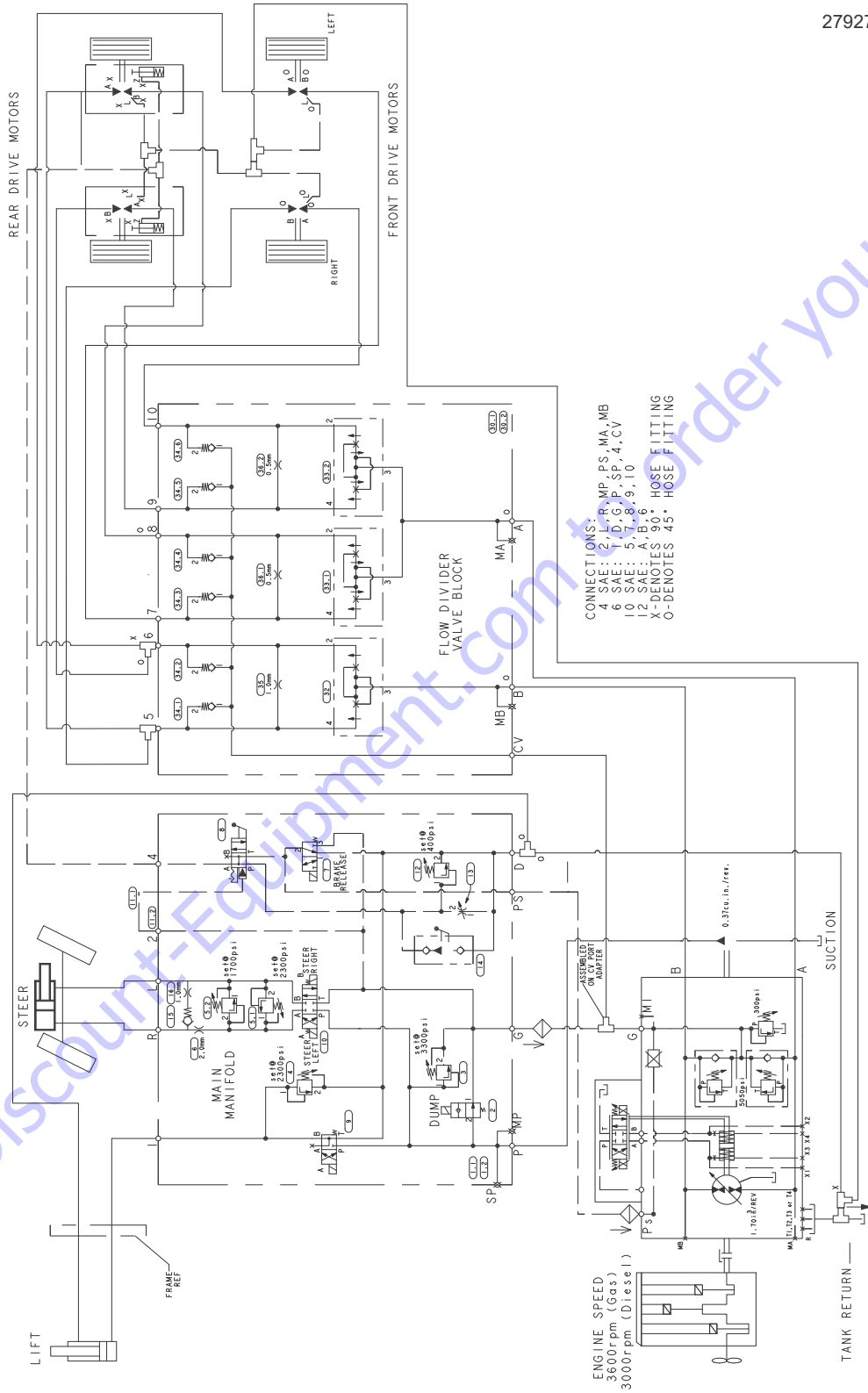

Figure 3-31. Hydraulic Schematic - S/N 141689 to Present

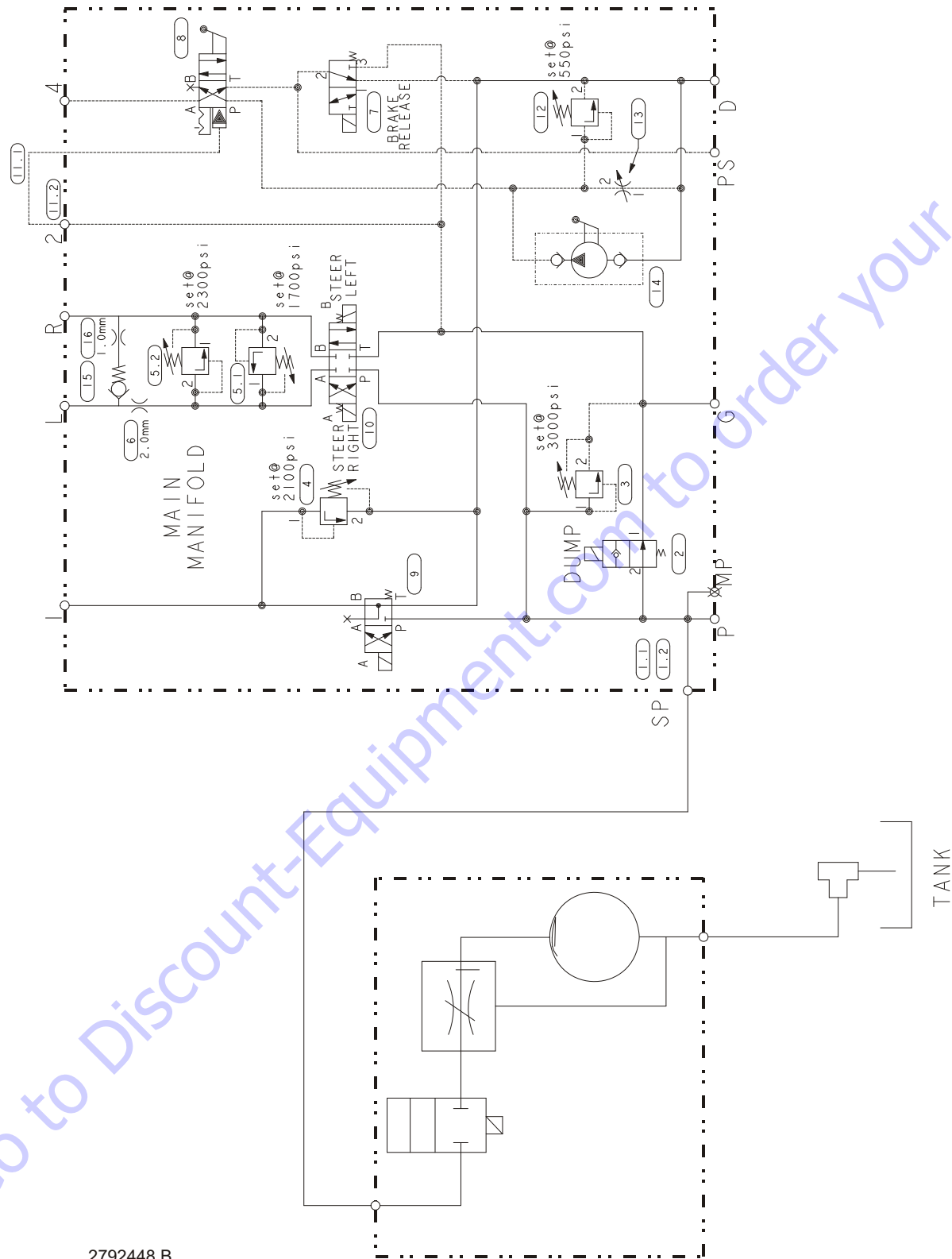

Figure 3-32. Hydraulic Diagram (Generator)

2792686 C

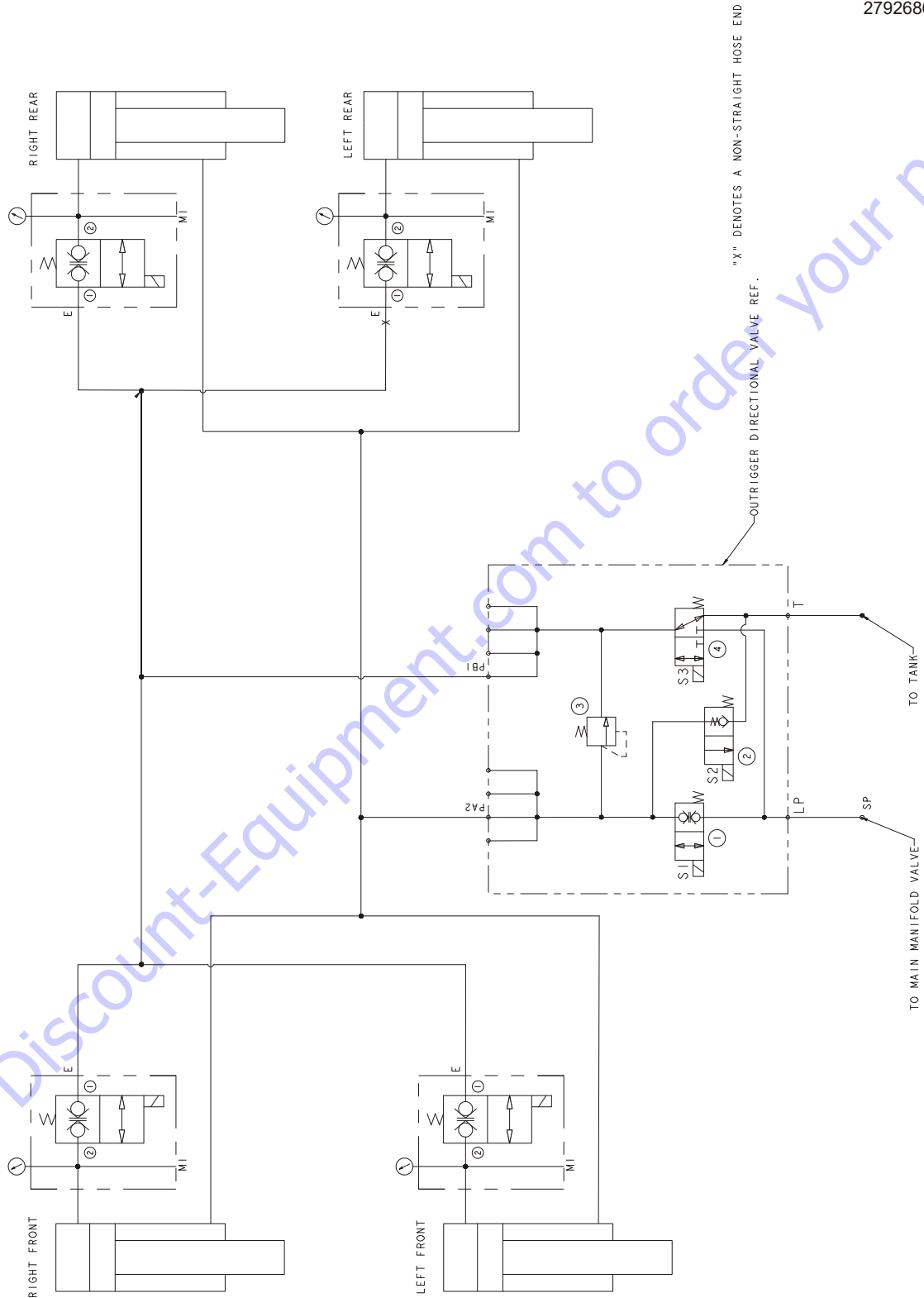

Figure 3-33. Hydraulic Diagram (Leveling Jacks)

 **NOTES:**

Two columns of horizontal lines for taking notes. The page is overlaid with a diagonal watermark: *Go to Discount-Equipment.com to order your parts*

PARTS FINDER

**Search Website
by Part Number**



**Search Manual
Library For Parts
Manual & Lookup Part
Numbers – Purchase
or Request Quote**

Search Manuals

Enter your information to search for manuals and parts.

* Brand:

* Model:

* Serial:

* Part Number:

SEARCH

**Can't Find Part or
Manual? Request Help
by Manufacturer,
Model & Description**

Parts Order Form

Please fill in the following information:

Manufacturer:

Model:

Description:

Quantity:

Part Number:

Part Name:

Part Description:

Part Location:

Part Condition:

Part Status:

Part Color:

Part Material:

Part Weight:

Part Dimensions:

Part Price:

Part Notes:

Submit

Discount-Equipment.com is your online resource for quality parts & equipment.

Florida: **561-964-4949** Outside Florida TOLL FREE: **877-690-3101**

Need parts?

Click on this link: <http://www.discount-equipment.com/category/5443-parts/> and choose one of the options to help get the right parts and equipment you are looking for. Please have the machine model and serial number available in order to help us get you the correct parts. If you don't find the part on the website or on one of the online manuals, please fill out the request form and one of our experienced staff members will get back to you with a quote for the right part that your machine needs.

We sell worldwide for the brands: Genie, Terex, JLG, MultiQuip, Mikasa, Essick, Whiteman, Mayco, Toro Stone, Diamond Products, Generac Magnum, Airman, Haulotte, Barreto, Power Blanket, Nifty Lift, Atlas Copco, Chicago Pneumatic, Allmand, Miller Curber, Skyjack, Lull, Skytrak, Tsurumi, Husquvarna Target, , Stow, Wacker, Sakai, Mi-T- M, Sullair, Basic, Dynapac, MBW, Weber, Bartell, Bennar Newman, Haulotte, Ditch Runner, Menegotti, Morrison, Contec, Buddy, Crown, Edco, Wyco, Bomag, Laymor, Barreto, EZ Trench, Bil-Jax, F.S. Curtis, Gehl Pavers, Heli, Honda, ICS/PowerGrit, IHI, Partner, Imer, Clipper, MMD, Koshin, Rice, CH&E, General Equipment, ,AMida, Coleman, NAC, Gradall, Square Shooter, Kent, Stanley, Tamco, Toku, Hatz, Kohler, Robin, Wisconsin, Northrock, Oztec, Toker TK, Rol-Air, Small Line, Wanco, Yanmar

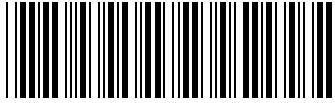

3121108



An Oshkosh Corporation Company

Go to Discount-Equipment.com to order your parts



www.Discount-Equipment.com