



TECHNICAL DATA

TANDEM ROLLERS

BW 900-50



www.discount-equipment.com



Go to Discount-Equipment.com to order your parts

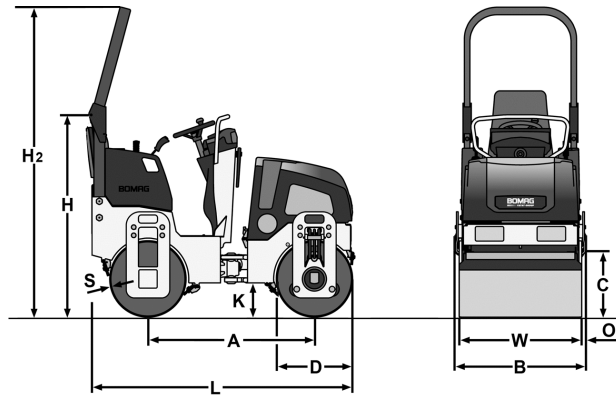

Dimensions in mm

	A	B	C	D	H	H2	K	L	O	S	W
BW 900-50	1223	961	450	560	1727	2290	250	1967	31	8	900

Shipping dimensions in m3

BW 900-50

without ROPS

3,265

with ROPS

4,901

Machine type	Compaction output (m3/h) at recommended soil layer thicknesses		
	Gravel, sand	Mixed soil	Silt, clay
BW 900-50	50-100	35-70	30-55

Machine type	Compaction output (t/h) at different asphalt layer thicknesses		
	2-4 cm	6-8 cm	10-14 cm
BW 900-50	10-25	20-40	30-60

Go to DiscountEquipment.com to order your parts

Technical Data**BOMAG
BW 900-50****Weights**

Operating weight CECE	kg	1.200
Average axle load CECE	kg	599
Average static linear load CECE	kg/cm	6,7

Dimensions

Working width	mm	900
Track radius, inner	mm	1.647

Driving Characteristics

Working speed with vibration	km/h	0- 4,0
Max. travel speed	km/h	0- 8,7
Max. gradeability without/with vibr.	%	40/30

Drive

Engine manufacturer		Honda
Type		GX 630
Cooling		air
Number of cylinders		2
Performance SAE J 1349	kW	14,9
Speed	min-1	3.300
Electric equipment	V	12
Drive system		hydrost.
Driven drum		2

Brakes

Service brake		hydrost.
Parking brake		mech.

Steering

Steering system		oscil.artic.
Steering method		hydrost.
Steering angle +/-	grad	33
Oscillating angle +/-	grad	6

Exciter system

Vibrating drum		front
Drive system		hydrost.
Frequency	Hz	70
Amplitude	mm	0,50
Centrifugal force	kN	15

Sprinkler System

Type of sprinkling		pressure
--------------------------	--	----------

Capacities

Fuel	l	27,0
Water	l	137,0

Technical modifications reserved. Machines may be shown with options.

Go to Discount-Equipment.com to order your parts

Standard Equipment

- Hydrostatic travel and vibration drive
- Travel drive in series
- Front drum vibration
- Vibration control in travel lever
- Oscillating artic. center joint
- Hydrostatic articulated steering
- Mechanical parking brake
- 2 scrapers per drum
- Plastic water tank
- Pressure sprinkler system
- Hour meter
- Low fuel level indicator
- Control and warning indicator lights
- Automatic shutdown at low oil level
- Lockable anti vandal dashboard protection
- Seat belt
- Single point lifting device
- Transport lashing and lifting points
front/rear
- Lockable engine cover
- Emergency engine shut down
- Corrosion and weather protected ignition
switch
- Back-up alarm

Optional Equipment

- ROPS
- Foldable ROPS
- Working lights front and rear



www.discount-equipment.com



TO PURCHASE THIS PRODUCT PLEASE CONTACT US



**Equipment Financing and
Extended Warranties Available**



**Discount-Equipment.com is your online resource for
commercial and industrial quality parts and equipment sales.**

561-964-4949

visit us on line @ www.discount-equipment.com

Select an option below to find your Equipment

Search by Manufacturer

Search by Product Type

Request a Quote

We sell worldwide for the brands: Genie, Terex, JLG, MultiQuip, Mikasa, Essick, Whiteman, Mayco, Toro Stone, Diamond Products, Generac Magnum, Airman, Haulotte, Barreto, Power Blanket, Nifty Lift, Atlas Copco, Chicago Pneumatic, Allmand, Miller Curber, Skyjack, Lull, Skytrak, Tsurumi, Husquvarna Target, Stow, Wacker, Sakai, Mi-T-M, Sullair, Basic, Dynapac, MBW, Weber, Bartell, Bennar Newman, Haulotte, Ditch Runner, Menegotti, Morrison, Contec, Buddy, Crown, Edco, Wyco, Bomag, Laymor, EZ Trench, Bil-Jax, F.S. Curtis, Gehl Pavers, Heli, Honda, ICS/PowerGrit, IHI, Partner, Imer, Clipper, MMD, Koshin, Rice, CH&E, General Equipment, Amida, Coleman, NAC, Gradall, Square Shooter, Kent, Stanley, Tamco, Toku, Hatz, Kohler, Robin, Wisconsin, Northrock, Oztec, Toker TK, Rol-Air, APT, Wylie, Ingersoll Rand / Doosan, Innovatech, Con X, Ammann, Mecalac, Makinex, Smith Surface Prep, Small Line, Wanco, Yanmar