



TEREX

TXC 300LC-1

Hydraulic Excavator

OPERATING WEIGHT	67,500 lbs (30,600 kg)
NET ENGINE POWER	197 hp (147 kW) @ 1,900 rpm
MAX DIG DEPTH	24' 1" (7,330 mm)
MAX REACH	35' 2" (10,735 mm)



FEATURES

- Powerful, quiet, fuel efficient, turbocharged USA EPA Tier 2 compliant diesel engine maximizes power output and utilization
- e-EPOS System uses variable displacement piston pumps ensuring high efficiency and lower fuel consumption
- Swing anti-rebound valve assures quick, precise, and smooth directional stops during dumping or cradling
- Exceptional bucket break-out and radial tooth forces for toughest digging
- Spacious, comfortable cab provides excellent visibility and ergonomic operating environment
- Advanced graphic display LCD information monitor panel makes troubleshooting easier, simplifies machine performance record keeping
- Standard equipped 3-switch joystick control and hydraulic piping to boom base facilitate installation of most attachments
- Equipped to maximize operator comfort, efficiency and performance
- More standard features to make this TEREX hydraulic excavator the most productive ever

HYDRAULIC EXCAVATOR
TXC 300LC-1

Specifications

Engine	
Model	DAEWOO DE08TIS
Type	Water-cooled, 4-cycle, direct injection, aspiration, turbocharged, air-to-air intercooled. USA EPA Tier 2 compliant.
No. of cylinders	6
Rated flywheel horsepower	
DIN 6271, net	200 PS (147 kW) @ 1,900 rpm
SAE J1349, net	197 HP (147 kW) @ 1,900 rpm
Piston displacement	493 cu. in. (8,071 cc)
Maximum torque	622 lbf.ft. (843 Nm) @ 1,300 rpm
Bore and stroke	4.4" x 5.5" (111 mm x 139 mm)
Starting system	24V electric motor
Batteries	2 x 12V x 150 AH

Hydraulic System	
e-EPOS (Electronic Power Optimizing System) allows the operator to maximize work efficiency over a full range of operating conditions and to minimize fuel consumption.	
Hydraulic system assures fully independent and combined operations.	
Automatic 2 speed travel system for high traction force and travel speed.	
Cross-sensing and fuel saving pump system.	
Auto idle system.	
2-Working / 2-power mode selection system.	
Computer aided engine-pump control.	
Main pumps	2 variable displacement axial piston pumps.
Max. oil flow	2 x 65.2 gpm (2 x 247 L/min)
Pilot pump	Gear pump
Max. oil flow	7.5 gpm (28.5 L/min)
Swing motor	
Relief valve	4,050 psi (279 bar)
Main relief valves	
Boom/Stick/Bucket	Normal: 4,690 psi (324 bar) Power Boost: 4,970 psi (343 bar)
Travel circuit	4,690 psi (324 bar)

Hydraulic Cylinders			
High-strength piston rods and tubes are used. Cylinder cushion mechanism is provided for all cylinders to minimize shock during operation and extend cylinder component life.			
Cylinders	Qty	Bore x Rod dia x Stroke	
Boom	2	5.5" x 3.7" x 56.7" (140 x 95 x 1,440 mm)	
Stick	1	5.9" x 4.1" x 69.1" (150 x 105 x 1,755 mm)	
Bucket	1	5.5" x 3.5" x 45.3" (140 x 90 x 1,050 mm)	

Superstructure Revolving Frame
Deep full-reinforced box section constructed of heavy gauge steel plates.

Operator's Cab	
Cab is independent and roomy. 4 side safety glass windows give excellent visibility. Front window slides up and stores in the roof and side window can be opened for ventilation. Fully adjustable suspension seat. Air conditioner. ISO standard cab.	
Noise Levels (dynamic value)	
LwA External noise	
Guaranteed Sound Power Level	105 dB(A) (2,000/14/EC)
Measured Sound Power Level	104 dB(A) (2,000/14/EC)
LpA Operator Noise	74 dB(A) (ISO 6396)

Controls - 2 Implement Levers
Pilot pressure control type. Right lever is boom and bucket control, left lever for swing and stick control.

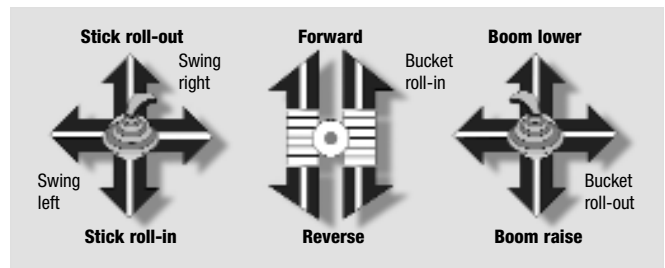

2 Travel Pedal with Levers
Pilot pressure control type. Independent drive at each track allows counter-rotation of the tracks. Levers are detachable.

Swing Mechanism	
High-torque, axial piston motor with planetary reduction gear in oil bath. Swing assembly is single row, shear type ball bearing with induction-hardened internal gear. Internal gear and pinion gear immersed in lubricant. Swing parking brake is spring-set, hydraulic-released disc type. A two position swing lock secures the superstructure for transportation.	
Swing speed	0 to 10.1 rpm
Rear swing radius	10' 6" (3,200 mm)

Drive	
Each track is driven by an independent, high-torque, axial piston motor through planetary reduction gearing. Two levers or foot pedal control provide smooth travel or counter-rotation upon demand.	
Travel speed (High/Low)	3.2/1.9 mph (5.1/3.0 km/h)
Maximum traction force	57,990 lbf (258 kN)
Gradeability	35° (70%) continuous

Brakes	
Two oil disc brakes outboard mounted on final drive input shafts. Parking brake is spring-set, hydraulic-released disc type.	

Specifications

Undercarriage

Tractor type undercarriage. Heavy-duty track frame, all welded stress-relieved structure. The highest grade materials are used for toughness. Side frames are welded, securely and rigidly, to the track frame. Lifetime-lubricated track rollers, idlers and sprockets with floating seals reduce field service requirements. Track shoes of induction-hardened rolled alloy with triple grousers ensure long life under the harshest applications. Specially heat-treated connecting pins reduce wear. Hydraulic track adjusters with shock-absorbing recoil springs are standard.

Number of rollers and shoes (each side) ground contact area

Upper rollers 2

(Standard Shoe)

Lower rollers 9

Track shoes 51

Overall track length 16' 2" (4,930 mm)

Weight

Equipped with 20' 6" (6.2 m) boom, 10' 2" (3.1 m) stick, and 1.66 yd³, PCSA heaped (1.27 m³) bucket.

Shoe type	Shoe width	Operating weight	Ground pressure
Triple grouser	24" (600 mm)	65,300 lb. (29,600 kg)	56 kpa, 8.1 psi
Triple grouser	28" (700 mm)	66,600 lb. (30,200 kg)	49 kpa, 9.1 psi
Triple grouser	32" (800 mm)	67,500 lb. (30,600 kg)	43 kpa, 6.2 psi
Triple grouser	34" (850 mm)	67,900 lb. (30,800 kg)	41 kpa, 6.0 psi

Service Refill Capacities

	U.S. gal	Liters
Fuel tank	118.8	450
Cooling system	11.4	43
Lubrication	U.S. gal	Liters
Engine oil	6.3	24
Swing drive (each)	1.6	6
Final drive (each)	1.1	4.3
Hydraulic system	76.6	290
Hydraulic tank	42.3	160

Buckets

Capacity PCSA heaped	Width without side cutters	Width with side cutters	Weight	Stick Recommendation	
				10' 2" (3.1 m)	12' 4" (3.75 m)
1.05 yd ³ (0.80 m ³)	36" (926 mm)	41" (1,035 mm)	1,900 lb. (863 kg)	A	A
1.37 yd ³ (1.05 m ³)	45" (1,136 mm)	49" (1,245 mm)	2,170 lb. (984 kg)	A	B
1.66 yd ³ (1.27 m ³)	53" (1,336 mm)	57" (1,445 mm)	2,380 lb. (1,080 kg)	A	B
1.96 yd ³ (1.50 m ³)	61" (1,546 mm)	65" (1,655 mm)	2,690 lb. (1,221 kg)	B	C
2.29 yd ³ (1.75 m ³)	69" (1,756 mm)	73" (1,865 mm)	2,925 lb. (1,326 kg)	C	—

A. Suitable for materials with density of 3,370 lb./cu.yd. (2,000 kg/m³) or less

B. Suitable for materials with density of 2,700 lb./cu.yd. (1,600 kg/m³) or less

C. Suitable for materials with density of 1,850 lb./cu.yd. (1,100 kg/m³) or less

Standard Equipment

Hydraulic System

Boom and stick flow regeneration • Boom and stick holding valves • Swing anti-rebound valves • Spare ports (valve) • One-touch power boost

Cab and Interior

All weather sound suppressed cab with suspension type mounts • Air conditioner (heavy duty) and heater/ defroster • Adjustable suspension seat with head rest and adjustable arm rest • Pull-up type front window and removable lower front window with storage brackets in cab • Roof hatch/cover • Cab light • Intermittent windshield wiper • Cigar lighter and ashtray • Cup holder • Hot and cold storage container • Graphic LCD display monitor • Fuel consumption controller • AM/FM Radio and cassette player • Remote radio ON/OFF switch • 12V spare power socket • Serial communication port for laptop PC interface • Joystick levers with 3 switches

Other

Large handrails and steps • Punched grid-type metal anti-slip upperstructure plates • Seat belt • Sun roof (hatch) • Hydraulic safety lock lever • Safety glass • Manual hammer mounted in cab for emergency use • Right and left rearview mirrors • Travel alarm • Heavy-duty fan guard • Dual element air cleaner • Pre-cleaner • Water separator • Double fuel filter • Radiator dust screen • Engine overheat prevention system • Engine restart prevention system • Self-diagnostic system • Heavy-duty alternator (24V, 80 amps) • Electric horn • Halogen working lights (frame mounted 2, boom mounted 2) • Hydraulic track adjuster • Sealed and greased track links • Track guards

Optional Equipment

Sun visor • Cab top/front guard (ISO 10262, FOGS standard) • Rotating beacon • Piping for hammer (one way) • Piping for optional implement rotation • Additional work lights on the cab (2 front lamps, 4 front and 2 rear lamps) • Electric fuel supply pump

Hydraulic Excavator TXC 300LC-1

Dimensions: 20' 6" (6.2 m) Boom, 10' 2" (3.1 m) Stick, 24" (600 mm) Shoe

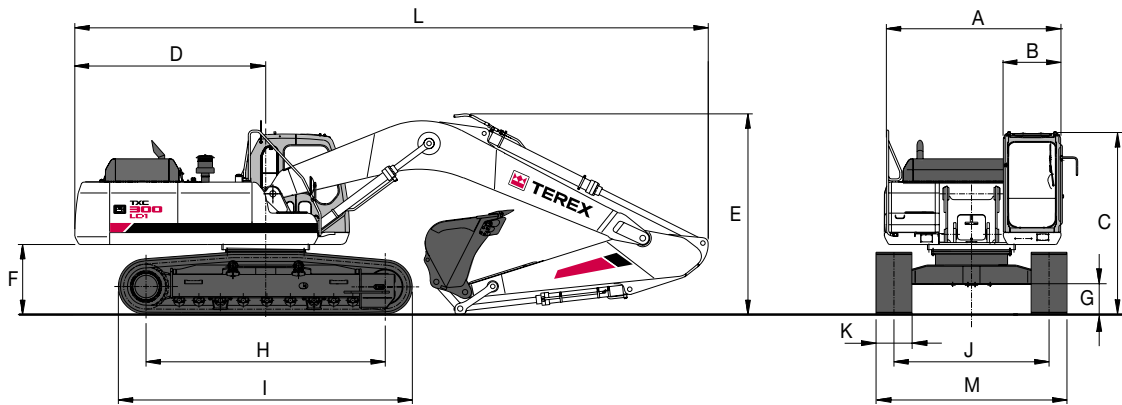

Dimensions

A Overall width of upperstructure	9' 9" (2,960 mm)
B Overall width of cab	3' 2" (960 mm)
C Overall height of cab	10' 1" (3,065 mm)
D Tail swing radius	10' 6" (3,200 mm)
E Overall height	11' 1" (3,365 mm)
F Clearance under counterweight	3' 10" (1,175 mm)
G Ground clearance	20" (500 mm)
H Idler to sprocket distance	13' 2" (4,010 mm)
I Track length	16' 2" (4,930 mm)
J Track gauge (Standard Track)	8' 6" (2,600 mm)
J1 Track gauge (Narrow Track)	7' 10" (2,400 mm)
K Track shoe width	24" (600 mm)
L Overall length	34' 10" (10,620 mm)
M Overall track width with 24" (600 mm) shoe	10' 6" (3,200 mm)

Digging Forces (Maximum radial tooth forces)

Stick	10' 2" (3.1 m)	12' 4" (3.75 m)
Bucket digging force*	39,900 lbf (177 kN)	39,900 lbf (177 kN)
Stick digging force*	29,500 lbf (131 kN)	26,800 lbf (119 kN)

*At power boost

Working Ranges

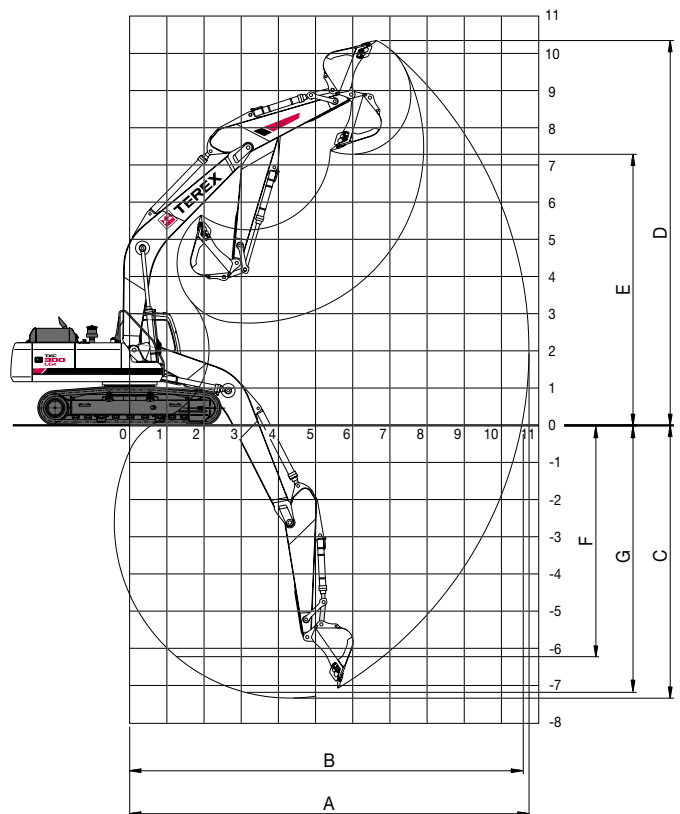

Boom Length: 20' 6" (6.2 m)

Stick length	10' 2" (3.1 m)	12' 4" (3.75 m)
A. Max. digging reach	35' 2" (10,735 mm)	37' 0" (11,290 mm)
B. Max. digging reach at ground level	34' 7" (10,540 mm)	36' 5" (11,105 mm)
C. Max. digging depth	24' 1" (7,330 mm)	26' 2" (7,980 mm)
D. Max. digging height	33' 11" (10,345 mm)	34' 6" (10,520 mm)
E. Max. dumping height	23' 11" (7,285 mm)	24' 6" (7,475 mm)
F. Max. vertical wall digging depth	20' 2" (6,145 mm)	22' 2" (6,745 mm)
G. Max. digging depth (8' level)	23' 5" (7,150 mm)	25' 7" (7,810 mm)



Lifting Capacities

Boom: 20' 6" Stick: 10' 2" Bucket: PCSA 1.66 yd ³ Shoe: 32" Weight: 67,072 lbs.													
Reach												unit: 1000 lb.	
Height	10ft F	10ft S	15ft F	15ft S	20ft F	20ft S	25ft F	25ft S	30ft F	30ft S	Max. F	Max. S	Reach (ft)
25 ft											*9.22	*9.22	@24.30
20 ft							*11.64	*11.64			*9.28	*9.28	@27.42
15 ft					*13.79	*13.79	*12.70	11.41			*9.70	8.57	@29.36
10 ft	*29.47	*29.47	*22.19	*22.19	*16.85	15.70	*14.30	10.97	*11.73	8.04	*10.47	7.87	@30.35
5 ft	*11.75	*11.75	*27.94	23.07	*19.91	14.89	*16.01	10.54	12.99	7.82	*11.68	7.61	@30.49
0 ft	*16.63	*16.63	*31.31	22.17	*22.20	14.32	17.03	10.20			12.95	7.74	@29.80
-5 ft	*25.08	*25.08	*32.26	21.85	*23.28	14.03	16.84	10.03			14.01	8.36	@28.20
-10 ft	*36.12	*36.12	*31.16	21.93	*22.87	14.02	16.88	10.06			16.36	9.77	@25.53
-15 ft	*39.52	*39.52	*27.64	22.36	*20.18	14.33					*18.42	13.00	@21.38
-20 ft											*20.03	*20.03	@14.50

Boom: 20' 6" Stick: 10' 2" Bucket: PCSA 1.66 yd ³ Shoe: 34" Weight: 67,531 lbs.													
Reach												unit: 1000 lb.	
Height	10ft F	10ft S	15ft F	15ft S	20ft F	20ft S	25ft F	25ft S	30ft F	30ft S	Max. F	Max. S	Reach (ft)
25 ft											*9.22	*9.22	@24.30
20 ft							*11.64	*11.64			*9.28	*9.28	@27.42
15 ft					*13.79	*13.79	*12.70	11.48			*9.70	8.63	@29.36
10 ft	*29.47	*29.47	*22.19	*22.19	*16.85	15.80	*14.30	11.05	*11.73	8.10	*10.47	7.93	@30.35
5 ft	*11.75	*11.75	*27.94	23.21	*19.91	14.99	*16.01	10.61	13.09	7.88	*11.68	7.67	@30.49
0 ft	*16.63	*16.63	*31.31	22.31	*22.20	14.41	17.15	10.28			13.05	7.80	@29.80
-5 ft	*25.08	*25.08	*32.26	22.00	*23.28	14.13	16.96	10.10			14.11	8.43	@28.20
-10 ft	*36.12	*36.12	*31.16	22.08	*22.87	14.12	17.00	10.14			16.48	9.84	@25.53
-15 ft	*39.52	*39.52	*27.64	22.51	*20.18	14.43					*18.42	13.09	@21.38
-20 ft											*20.03	*20.03	@14.50

Notes:

1. Ratings are based on SAE J1097
2. Load point is the hook on the back of the bucket.
3. *Rated loads are based on hydraulic capacity.
4. Rated loads do not exceed 87% of hyd. capacity or 75% of tipping capacity.

-  F = Rating over front
 S = Rating over side or 360 degree
 0 = Ground

Hydraulic Excavator TXC 300LC-1



Lifting Capacities

Boom: 20' 6" Stick: 12' 4" Bucket: PCSA 1.37 yd ³ Shoe: 32" Weight: 66,894 lbs.													
Reach													unit: 1000 lb.
Height	10ft F	10ft S	15ft F	15ft S	20ft F	20ft S	25ft F	25ft S	30ft F	30ft S	Max. F	Max. S	Reach (ft)
25 ft							*10.05	*10.05			*8.50	*8.50	@26.69
20 ft							*10.37	*10.37			*8.54	*8.54	@29.55
15 ft							*11.59	*11.59	*11.38	8.57	*8.88	7.89	@31.36
10 ft	*29.91	*29.91	*19.40	*19.40	*15.36	*15.36	*13.34	11.34	*12.27	8.33	*9.49	7.30	@32.29
5 ft	*19.43	*19.43	*25.78	23.80	*18.72	15.33	*15.26	10.85	13.24	8.07	*10.45	7.06	@32.42
0 ft	*18.32	*18.32	*30.20	22.61	*21.47	14.63	*16.93	10.44	13.00	7.84	11.89	7.15	@31.77
-5 ft	*23.91	*23.91	*32.20	22.06	*23.11	14.23	17.00	10.18	12.87	7.72	12.69	7.61	@30.28
-10 ft	*32.51	*32.51	*32.08	21.97	*23.39	14.10	16.92	10.12			14.42	8.66	@27.81
-15 ft	*43.60	*43.60	*29.76	22.23	*21.87	14.25					*17.23	10.88	@24.06
-20 ft	*34.57	*34.57	*24.03	22.91							*19.14	16.95	@18.25

Boom: 20' 6" Stick: 12' 4" Bucket: PCSA 1.37 yd ³ Shoe: 34" Weight: 67,335 lbs.													
Reach													unit: 1000 lb.
Height	10ft F	10ft S	15ft F	15ft S	20ft F	20ft S	25ft F	25ft S	30ft F	30ft S	Max. F	Max. S	Reach (ft)
25 ft							*10.05	*10.05			*8.50	*8.50	@26.69
20 ft							*10.37	*10.37			*8.54	*8.54	@29.55
15 ft							*11.59	*11.59	*11.38	8.63	*8.88	7.95	@31.36
10 ft	*29.91	*29.91	*19.40	*19.40	*15.36	*15.36	*13.34	11.41	*12.27	8.39	*9.49	7.35	@32.29
5 ft	*19.43	*19.43	*25.78	23.95	*18.72	15.43	*15.26	10.92	*13.33	8.13	*10.45	7.12	@32.42
0 ft	*18.32	*18.32	*30.20	22.75	*21.47	14.73	*16.93	10.52	13.10	7.90	*11.92	7.20	@31.77
-5 ft	*23.91	*23.91	*32.20	22.20	*23.11	14.32	17.12	10.26	12.96	7.78	12.79	7.67	@30.28
-10 ft	*32.51	*32.51	*32.08	22.11	*23.39	14.20	17.04	10.19			14.53	8.72	@27.81
-15 ft	*43.60	*43.60	*29.76	22.37	*21.87	14.35					*17.23	10.96	@24.06
-20 ft	*34.57	*34.57	*24.03	23.05							*19.14	17.06	@18.25

Notes:

1. Ratings are based on SAE J1097
2. Load point is the hook on the back of the bucket.
3. *Rated loads are based on hydraulic capacity.
4. Rated loads do not exceed 87% of hyd. capacity or 75% of tipping capacity.

 F = Rating over front
 S = Rating over side or 360 degree
 0 = Ground



For more information, product demonstration, or details on purchase, lease and rental plans, please contact your local TEREX Distributor.

TEREX Construction Americas

8800 Rostin Road
Southaven, MS 38671
USA

TEL 662-393-1800
SALES 866-837-3923
PARTS & TECH SUPPORT 888-201-6008
FAX 662-393-1700
EMAIL sales@terexca.com
WEB terexca.com

Effective date: January 1, 2005. For further information, please contact your local distributor or the TEREX sales office listed. Continuous improvement of our products is a TEREX policy. Product specifications are subject to change without notice or obligation. The photographs and drawings in this brochure are for illustrative purposes only. Refer to the appropriate Operator's Manual for instructions on the proper use of this equipment. Failure to follow the appropriate Operator's Manual when using our equipment or to otherwise act irresponsibly may result in serious injury or death. Prices and specifications subject to change without notice. The only warranty applicable is the standard written warranty applicable to the particular product and sale. TEREX makes no other warranty, expressed or implied. Products and services listed may be trademarks, service marks or trade-names of TEREX Corporation and/or its subsidiaries in the USA and other countries and all rights are reserved. "TEREX" is a Registered Trademark of TEREX Corporation in the USA and many other countries. Copyright ©2005 TEREX Corporation
TXL 300LC-1 SK 0305B Part #109076

Dimensions

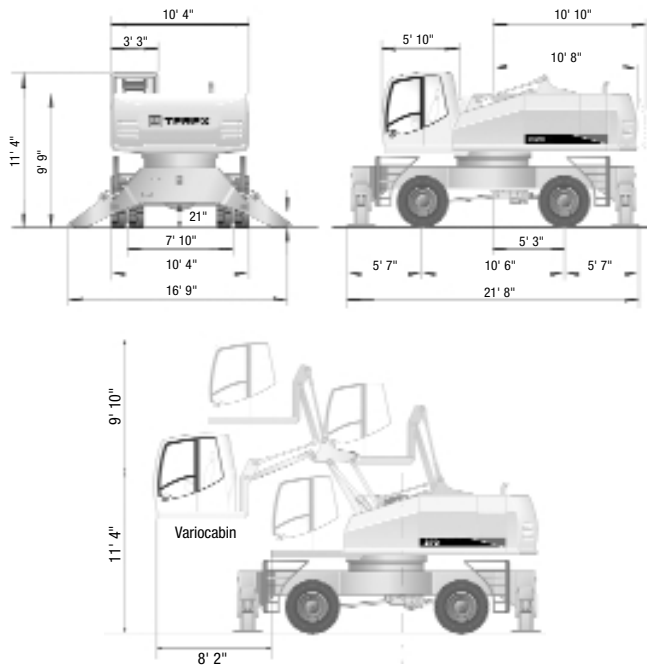

Boom Systems

Monobloc boom C 94.5i
with D 94.15i jib Effective length 32' 2" with
effective length 24' 7"

Monobloc C 94.6i
with D 94.16i jib Effective length 39' 8" with
effective length 30' 4"

Equipment

Base Unit

A 94.32 Fully hydraulic mobile material handling machine
with four-fold stabilizers and two lifting rams 94,484 lbs

Additional Equipment

B 94.9 Hydraulic installation to operate front and rear
stabilizers separately 44 lbs

B 94.9b Hydraulic installation to operate each stabilizer
individually 88 lbs

Main Boom

C 94.5i Monobloc boom with two lateral jib rams
effective length 32' 2" 8,820 lbs

C 94.6i Monobloc boom with two lateral jib rams
effective length 39' 8" 9,592 lbs

Jibs

D 94.15i Jib suitable for C 94.5i, boom effective length 24' 7" 4,741 lbs

D 94.16i Jib suitable for C 94.6i, boom effective length 30' 4" 5,292 lbs

Standard Equipment

AEM EXCAVATOR MANAGEMENT electronic system
LCD showing operating data
Air conditioned cab
Variocabin, allowing 9' 10" lift and 9' 10" forward movement (infinitely)
Travelling with foot pedals
Travelling direction to be selected with the joy-sticks
Automatic idling of the diesel engine
Steering via potentiometer (no steering wheel) and joy-sticks with push button (for offroad driving)
Heat insulated and tinted windows, wind screen washer
Up and over windscreen lockable under roof panel
Sliding window in the cab door
Comfort seat with arm rests and lumbar support, fold away arm rest
Forward and reverse seat adjustment independent of the control panel
Cab prepared for radio installation
Battery main switch in the negative wire
Emergency boom lowering accumulator
Central lubrication point (electronic) for the swing gear and the boom pivot pins, combined lubrication points for the Variocabin
Sealed main boom pivot pins
Hydraulic mounting set for grab operation and grab rotation
Oil distribution via valve block with electrically pilot controlled valve sections
Protected piston rods for the stabilizer rams
Super elastic tires with intermediate rings
Tool box in the superstructure
Isolating stop valves in the lifting and jib rams
Overload warning device

Range

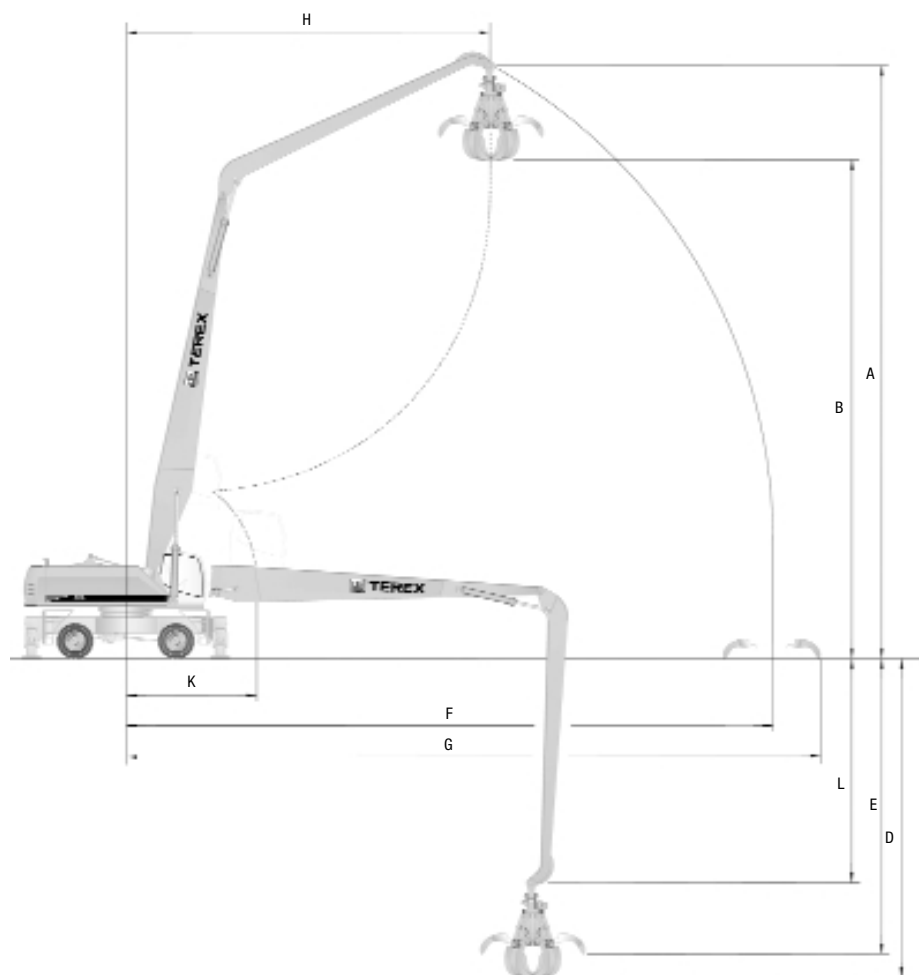

Jib D 94.15i - Effective length 24' 7"

Equipment: A 94.32, C 94.5i, D 94.15i, E 94.50
Orange peel grab

A Jib height ft./in.	52' 6"
B Dumping height ft./in.	42' 6"
F Max. length of jib ft./in.	54' 9"
G Max. outreach ft./in.	59' 7"
H Max. outreach length ft./in.	37' 9"
K Min. length of jib ft./in.	12' 10"
L Bucket pivot ft./in.	17' 2"
E Max. open grab ft./in.	24' 3"
D Max. digging depth ft./in.	27' 7"
Operating weight	112,235 lbs

Jib D 94.16i - Effective length 30' 4"

Equipment: A 94.32, C 94.6i, D 94.16i, E 94.50
Orange peel grab

A Jib height ft./in.	62' 6"
B Dumping height ft./in.	52' 8"
F Max. length of jib ft./in.	66' 11"
G Max. outreach ft./in.	71' 8"
H Max. outreach length ft./in.	37' 9"
K Min. length of jib ft./in.	15' 1"
L Bucket pivot ft./in.	23' 7"
E Max. open grab ft./in.	30' 2"
D Max. digging depth ft./in.	33' 8"
Operating weight	114,329 lbs

Lift Cap.: Equipment A 94.32, C94.5i

Jib D 94.15i - Effective length 24' 7"

Hook height ft.	25 ft		30 ft		35 ft		40 ft		45 ft		50 ft		
	F	S	F	S	F	S	F	S	F	S	F	S	
40	a	-	-	-	16.7	16.7	15.7	15.7	-	-	-	-	
	b	-	-	-	16.7	15.2	15.1	12.0	-	-	-	-	
30	a	-	-	-	17.5	17.5	16.1	16.1	15.0	15.0	-	-	
	b	-	-	-	17.5	14.7	14.8	11.7	12.1	9.5	-	-	
20	a	25.6	25.6	22.0	22.0	19.3	19.3	17.3	17.3	15.8	15.8	14.5	14.5
	b	25.6	22.8	21.9	17.3	17.3	13.6	14.8	11.0	11.6	9.0	9.7	7.4
10	a	31.2	31.2	25.4	25.4	21.5	21.5	18.8	18.8	16.6	16.6	14.9	14.9
	b	25.3	19.3	19.6	15.1	15.8	12.2	13.0	10.0	10.9	8.3	9.2	7.0
0	a	32.6	32.6	27.4	27.4	22.9	22.9	19.6	19.6	17.0	17.0	14.9	14.9
	b	22.5	16.8	17.8	13.4	14.5	11.0	12.1	9.2	10.3	7.7	8.8	6.6
-10	a	26.2	26.2	26.7	26.7	22.3	22.3	19.0	19.0	16.2	16.2	13.7	13.7
	b	21.6	15.9	17.0	12.6	13.9	10.4	11.7	8.7	10.0	7.7	8.7	6.5

Load capacities in 1,000 lbs

The stated maximum payload volume in pounds (1,000) include a stability margin of 33% or are calculated at 87% of the hydraulic lifting force in accordance with ISO 10567 standard. These values apply at the jib end when the boom-jib system is in the optimal position.

Lift Cap.: Equipment A 94.32, C94.6i

Jib D 94.15i - Effective length 30' 4"

Hook height ft.	35 ft		40 ft		45 ft		50 ft		55 ft		60 ft		65 ft		
	F	S	F	S	F	S	F	S	F	S	F	S	F	S	
50	a	-	-	-	11.4	11.4	10.6	10.6	-	-	-	-	-	-	
	b	-	-	-	11.4	9.8	10.1	7.8	-	-	-	-	-	-	
40	a	-	-	-	11.5	11.5	10.7	10.7	9.9	9.9	-	-	-	-	
	b	-	-	-	11.5	9.7	10.1	7.8	8.2	6.2	-	-	-	-	
30	a	-	-	13.3	13.3	12.1	12.1	11.0	11.0	10.2	10.2	9.4	9.4	-	-
	b	-	-	13.3	11.5	11.8	9.1	9.7	7.4	8.0	5.9	6.6	4.7	-	-
20	a	16.6	16.6	14.5	14.5	12.9	12.9	11.6	11.6	10.5	10.5	9.6	9.6	8.8	8.8
	b	16.4	12.7	13.2	10.1	10.8	8.2	8.9	6.6	7.4	5.4	6.2	4.4	5.2	3.5
10	a	18.4	18.4	15.7	15.7	13.7	13.7	12.2	12.2	10.9	10.9	9.8	9.8	8.9	8.9
	b	14.2	10.5	11.6	8.6	9.6	7.1	8.1	5.8	6.8	4.8	5.8	4.0	4.9	3.3
0	a	19.4	19.4	16.5	16.5	14.3	14.3	12.5	12.5	11.1	11.1	9.8	9.8	8.7	8.7
	b	12.3	8.8	10.2	7.3	8.6	6.1	7.3	5.1	6.3	4.3	5.4	3.6	4.6	3.0
-10	a	19.2	19.2	16.3	16.3	14.1	14.1	12.3	12.3	10.7	10.7	9.3	9.3	-	-
	b	11.2	7.8	9.4	6.5	8.0	5.4	6.8	4.6	5.9	3.9	5.1	3.4	-	-

Load capacities in 1,000 lbs

a = Stabilizers down b = Wheels down F = Rating over front S = Rating over side

Material Handler 370

Transport Dimensions

Boom system

C 94.5i with D 94.15i

Length A 49' 6"

Height B 11' 4"

Boom system

C 94.6i with D 94.16i

Length A 55' 1"

Height B 11' 4"

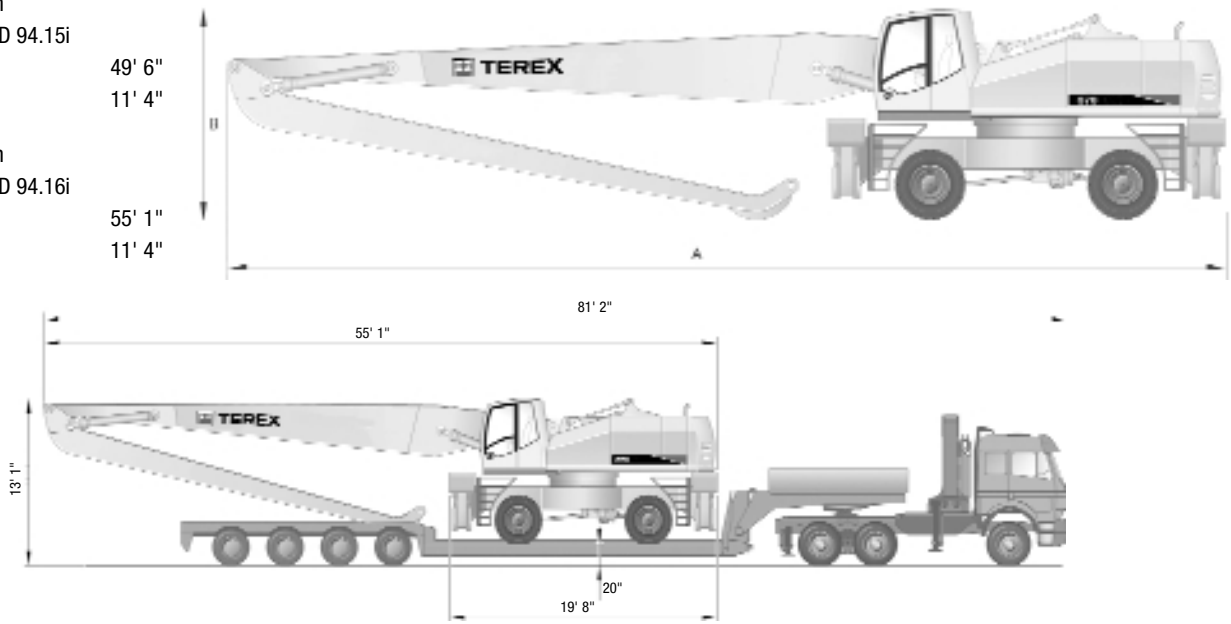

Accessories

	Type	Capacity (SAE) gallon	Width inch	Width completely open grab- inch	Weight lbs (pound)
Bulk grab	E 94.53	660	79	104	4,410
Orange peel grab	E 94.50	291	open	114	3,484
	E 94.51	291	half closed	114	3,793
Log grab	E 94.60	13 square foot	28	108	3,969
	E 94.61	16 square foot	32	122	5,072
Quick release equipment	T 82				269
Linkage	T 832				278
Grab rotator	E 832				397
Grab rotating device	T 713				55
Hook	K 713				110
	K 713 SW				172



For more information, product demonstration, or details on purchase, lease and rental plans, please contact your local TEREX Distributor.

TEREX Construction Americas

8800 Rostin Road
Southaven, MS 38671
USA

TEL 662-393-1800
SALES 866-837-3923
PARTS & TECH SUPPORT 888-201-6008
FAX 662-393-1700
EMAIL sales@terexca.com
WEB terexca.com

Effective date: January 1, 2005. For further information, please contact your local distributor or the TEREX sales office listed. Continuous improvement of our products is a TEREX policy. Product specifications are subject to change without notice or obligation. The photographs and drawings in this brochure are for illustrative purposes only. Refer to the appropriate Operator's Manual for instructions on the proper use of this equipment. Failure to follow the appropriate Operator's Manual when using our equipment or to otherwise act irresponsibly may result in serious injury or death. Prices and specifications subject to change without notice. The only warranty applicable is the standard written warranty applicable to the particular product and sale. TEREX makes no other warranty, expressed or implied. Products and services listed may be trademarks, service marks or trade-names of TEREX Corporation and/or its subsidiaries in the USA and other countries and all rights are reserved. "TEREX" is a Registered Trademark of TEREX Corporation in the USA and many other countries. Copyright ©2005 TEREX Corporation