



# TEREX

# 2205 M

## Wheeled Excavator

<b>OPERATING WEIGHT</b>	45,636 – 46,517 lbs (20 700 – 21 100 kg)
<b>NET ENGINE POWER</b>	182 HP (134 kW)
<b>MAX DIG DEPTH</b>	22' 2" (6.75 m)
<b>MAX REACH</b>	34' 3" (10.5 m)



WHEELED EXCAVATOR

# 2205 M

### FEATURES

- High stability and high dig forces due to optimum weight distribution and precise balance of machine's center of gravity.
- Powerful, quiet, fuel efficient, turbocharged diesel engine maximizes power output and utilization.
- Precision hydraulic components provide smooth reliable control, independent of load, to multiple functions simultaneously.
- AEM control monitoring system provides simple, informative interface between the operator and the machine.
- Spacious and comfortable cab includes 12 ventilation jets and air conditioning standard.
- Panoramic windows and minimum obstructions optimize visibility.

## Specifications

Engine	
Manufacturer / Model	Deutz / BF6M 2012 C
Type	Turbocharged, water cooled, intercooler
Net HP (ISO1585)	182 HP (134 kW)
Displacement	366 in <sup>3</sup> (6057 cm <sup>3</sup> )
Max. RPM	2000
Batteries	2 x 12 V x 100 AH

Hydraulic System	
Computer controlled AWE5 system with one load limit controlled high performance piston pump. All functions are proportional with independent load control and protected against cavitation. There are primary and secondary hydraulic reliefs in the case of system overload. Hydraulic cooling system is an isolated system with a temperature controlled cooling fan to minimize fuel consumption.	
Main Pump	HPR 105
Max. gear pump output	111 gpm (460 l/min)
Max. operation pressure	5511 psi (380 bar)

Noise Level	
Outside the cab	104 dBA
Inside the cab	75 dBA
(Measurements per 2000 / 14 EU regulations)	

Brakes	
Dual-circuit brake system	Multi-discs
Parking brakes	Multi-discs

Operator's Cab	
Spacious cab equipped with panoramic windows for optimum visibility. Seat and steering column are fully adjustable independent of one another. Front window slides up and stores in the roof and the side window opens for added ventilation. Air conditioning is standard.	

Fluid Capacities	
Fuel tank	106 gal (400 l)
Hydraulic tank	58.1 gal (220 l)
Engine oil	3.70 gal (14 l)

Swing Mechanism	
Motor	Axial piston
Gears	Planetary transmission
Brake (parking)	Automatic multi-disc
Max. speed	9 RPM
Max. torque	49,930 lbf•ft. (67.6 kNm)

Drive	
The power transmission is hydraulically driven and provides a 40:1 gear reduction. Oscillating front axle with pendulum lock-out. All-wheel drive with infinitely variable speed control forward and reverse in 3 speed ranges:	
Off-road low	0-621 mph (0-1.0 kmh)
Off-road high	0-3.1 mph (0-5.0 kmh)
On-road high	0-12.4 mph (0-20.0 kmh)

Tires	
8-ply	10.00 – 20
Turning radius	24 ft. 7 in. (7.5 m)

## Standard Equipment

Chassis
Wheels with intermediate rings • Battery main switch • Emergency lowering system of the stick • Toolbox on the chassis • Grab handle for securing the grab attachment while driving • Centralized lubrication points • Cold start package • Automatic swing brake • Powershift transmission

Boom
Auxiliary hydraulics for grab attachments • Auxiliary hydraulics for hammer attachments • Lifting cylinders overload protection with warning device

Other
Sliding cab door window • Tinted windows • "Drive" with foot pedals • Self-diagnostic system • AEM excavator management system • Suspension type cab mounts • Automatic engine idle • Windshield wipers and wash • Air conditioning • AM/FM radio with cassette player • Adjustable steering column, tilt and telescope • Adjustable suspension seat with arm rests • Storage compartment in the cab • Cigarette lighter, 24 volts • Cup holders • Interior cab light • Rearview mirror • Travel alarm

## Optional Equipment

### Chassis

Outriggers, front and back • Blades and two outriggers  
 • 8 MITAS 10.00 - 20, 16 PR tires • 8 super-elastic 10.00 - 20 tires  
 • Electric refueling pump • Secondary toolbox on chassis • Electronic centralized lubrication

### Other

Custom paint • Work lights • Heated air cushioned seat • Break-proof LEXAN for front and top panes • Top and front cab protection

### Boom and Stick

Two piece boom	13' 9" (4.19 m)
One piece boom	19' 0" (5.79 m)
Stick	7' 3" (2.21m) or 8' 10" (2.69 m)

## Dimensions

### Principal Dimensions

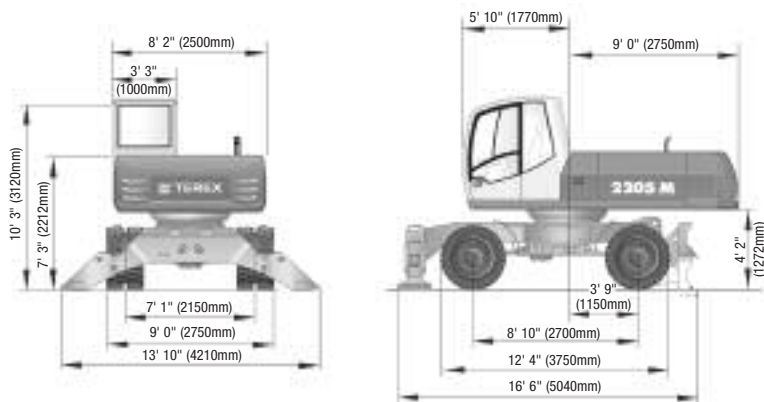

### Travel Position w/Bucket



### Shipping Dimensions (L x W x H)

Two Piece Boom	32' 7" x 9' 0" x 10' 6" (9.94 x 2.75 x 3.20 m)
One Piece Boom	34' 5" x 9' 0" x 10' 6" (10.50 x 2.75 x 3.20 m)

## Working Range: Two Piece Boom 13' 9" (4.19 m)

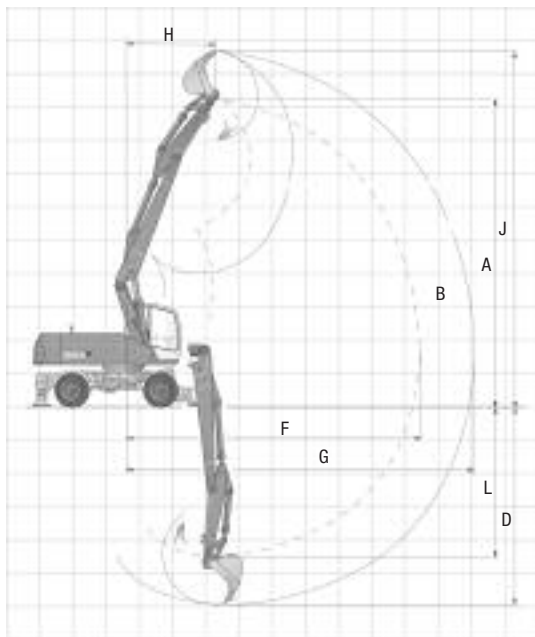

		Standard stick 7' 3" (2.21 m)	Optional stick 8' 10" (2.69 m)	
A	Stick height	ft./in. (mm)	31' 0" (9450)	32' 4" (9850)
D	Max. digging depth	ft./in. (mm)	20' 6" (6250)	22' 2" (6750)
F	Max. radius	ft./in. (mm)	27' 9" (8450)	29' 0" (8850)
G	Max. reach length	ft./in. (mm)	32' 8" (9950)	34' 3" (10 450)
H	Max. stick position	ft./in. (mm)	9' 0" (2750)	10' 0" (3050)
J	Max. outreach height	ft./in. (mm)	35' 11" (10 950)	37' 3" (11 350)
L	Bucket pivot point	ft./in. (mm)	15' 3" (4650)	16' 9" (5100)
<b>Digging Forces</b>				
	Bucket	yd <sup>3</sup> (l)	1.49 (1140)	1.49 (1140)
	Tear-out force	lbf (kN)	28,550 (127)	24,730 (110)
	Break-out force	lbf (kN)	39,570 (176)	39,570 (176)
<b>Weight</b>				
	Operating weight	lbs. (kg)	46,297 (21 000)	46,517 (21 100)

# Wheeled Excavator 2205 M

## Working Range: One Piece Boom 19' 0" (5.79 m)

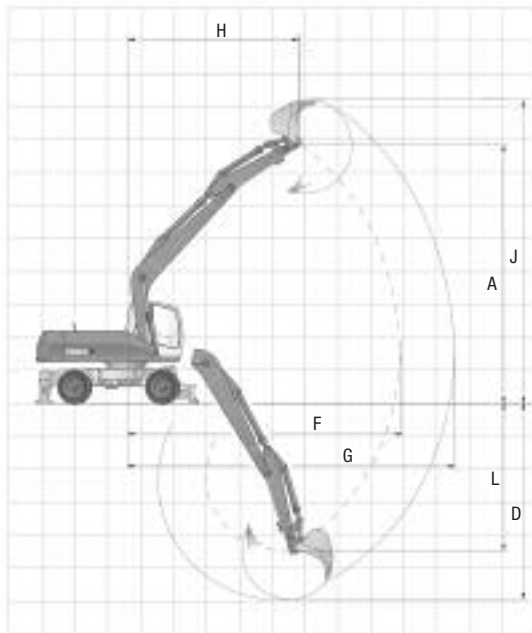

		Standard stick 7' 3" (2.21 m)	Optional stick 8' 10" (2.69 m)	
A	Stick height	in. (mm)	26' 3" (8000)	26' 9" (8150)
D	Max. digging depth	in. (mm)	19' 2" (5850)	21' 8" (6600)
F	Max. radius	in. (mm)	27' 1" (8260)	28' 8" (8750)
G	Max. reach length	in. (mm)	31' 11" (9720)	33' 10" (10 300)
H	Max. stick position	in. (mm)	17' 1" (5200)	18' 4" (5600)
J	Max. outreach height	in. (mm)	29' 8" (9050)	31' 8" (9500)
L	Bucket pivot point	in. (mm)	14' 9" (4500)	15' 7" (4750)
<b>Digging Forces</b>				
	Bucket/grab	yd <sup>3</sup> (l)	1.75 (1340)	1.49 (1140)
	Tear-out force	lbf (kN)	28,780 (128)	25,180 (112)
	Break-out force	lbf (kN)	35,970 (160)	35,970 (160)
<b>Weight</b>				
	Operating weight	lbs. (kg)	45,636 (20 700)	45,856 (20 800)

## Attachments



Capacity*	cu. yd. (l)	1.75 (1340)	1.49 (1140)	1.21 (930)	0.99 (760)
Width*	in. (mm)	59.1 (1500)	51.2 (1300)	43.3 (1100)	33.5 (850)
Dozer blade max. reach	ft./in. (m)	19' 8" (6.0)	21' 4" (6.5)	24' 7" (7.5)	27' 11" (8.5)
Support pads at both ends max. reach	ft./in. (m)	29' 6" (9.0)	31' 2" (9.5)	32' 10" (10.0)	34' 5" (10.5)

\*Permitted bucket attachments for max. radius F

Stability acc. to ISO 10567, bulk weight 112 lbs/ft<sup>3</sup> (1.8 t/m<sup>3</sup>)



For more information, product demonstration, or details on purchase, lease and rental plans, please contact your local TEREX Distributor.

### TEREX Construction Americas

8800 Rostin Road  
Southaven, MS 38671  
USA

TEL 662-393-1800  
SALES 866-837-3923  
PARTS & TECH SUPPORT 888-201-6008  
FAX 662-393-1700  
EMAIL sales@terexca.com  
WEB terexca.com

Effective date: January 1, 2005. For further information, please contact your local distributor or the TEREX sales office listed. Continuous improvement of our products is a TEREX policy. Product specifications are subject to change without notice or obligation. The photographs and drawings in this brochure are for illustrative purposes only. Refer to the appropriate Operator's Manual for instructions on the proper use of this equipment. Failure to follow the appropriate Operator's Manual when using our equipment or to otherwise act irresponsibly may result in serious injury or death. Prices and specifications subject to change without notice. The only warranty applicable is the standard written warranty applicable to the particular product and sale. TEREX makes no other warranty, expressed or implied. Products and services listed may be trademarks, service marks or trade-names of TEREX Corporation and/or its subsidiaries in the USA and other countries and all rights are reserved. "TEREX" is a Registered Trademark of TEREX Corporation in the USA and many other countries. Copyright ©2005 TEREX Corporation

2205M .5K 0305B Part# 109002