



An Oshkosh Corporation Company



www.Discount-Equipment.com

Service and Maintenance Manual

Model

10MSP

Vertical Lift

3121228

June 29, 2018 - Rev K

ANSI



CE

AS/NZS



An Oshkosh Corporation Company

MAINTENANCE SAFETY PRECAUTIONS

A. GENERAL

This section contains the general safety precautions which must be observed during maintenance of the aerial platform. It is of utmost importance that maintenance personnel pay strict attention to these warnings and precautions to avoid possible injury to themselves or others or damage to the equipment. A maintenance program must be followed to ensure that the machine is safe to operate.

⚠ WARNING

MODIFICATION OR ALTERATION OF AN AERIAL WORK PLATFORM SHALL BE MADE ONLY WITH WRITTEN PERMISSION FROM THE MANUFACTURER.

The specific precautions to be observed during maintenance are inserted at the appropriate point in the manual. These precautions are, for the most part, those that apply when servicing hydraulic and larger machine component parts.

Your safety, and that of others, is the first consideration when engaging in the maintenance of equipment. Always be conscious of weight. Never attempt to move heavy parts without the aid of a mechanical device. Do not allow heavy objects to rest in an unstable position. When raising a portion of the equipment, ensure that adequate support is provided.

⚠ WARNING

SINCE THE MACHINE MANUFACTURER HAS NO DIRECT CONTROL OVER THE FIELD INSPECTION AND MAINTENANCE, SAFETY IN THIS AREA IS THE RESPONSIBILITY OF THE OWNER/OPERATOR.

B. HYDRAULIC SYSTEM SAFETY

It should be noted that the machine's hydraulic systems operate at extremely high and potentially dangerous pressures. Every effort should be made to relieve any system pressure prior to disconnecting or removing any portion of the system.

Do not use your hand to check for leaks. Use a piece of cardboard or paper to search for leaks. Wear gloves to help protect hands from spraying fluid.



C. MAINTENANCE

⚠ WARNING

FAILURE TO COMPLY WITH SAFETY PRECAUTIONS LISTED IN THIS SECTION COULD RESULT IN MACHINE DAMAGE, PERSONNEL INJURY OR DEATH AND IS A SAFETY VIOLATION.

- ENSURE REPLACEMENT PARTS OR COMPONENTS ARE IDENTICAL OR EQUIVALENT TO ORIGINAL PARTS OR COMPONENTS.
- NO SMOKING IS MANDATORY. NEVER REFUEL DURING ELECTRICAL STORMS. ENSURE THAT FUEL CAP IS CLOSED AND SECURE AT ALL OTHER TIMES.
- REMOVE ALL RINGS, WATCHES, AND JEWELRY WHEN PERFORMING ANY MAINTENANCE.
- DO NOT WEAR LONG HAIR UNRESTRAINED, OR LOOSE FITTING CLOTHING AND NECKTIES WHICH ARE APT TO BECOME CAUGHT ON OR ENTANGLED IN EQUIPMENT.
- OBSERVE AND OBEY ALL WARNINGS AND CAUTIONS ON MACHINE AND IN SERVICE MANUAL.
- KEEP OIL, GREASE, WATER, ETC. WIPED FROM STANDING SURFACES AND HAND HOLDS.
- NEVER WORK UNDER AN ELEVATED PLATFORM UNTIL PLATFORM HAS BEEN SAFELY RESTRAINED FROM ANY MOVEMENT BY BLOCKING OR OVERHEAD SLING, OR SAFETY PROP HAS BEEN ENGAGED.
- BEFORE MAKING ADJUSTMENTS, LUBRICATING OR PERFORMING ANY OTHER MAINTENANCE, SHUT OFF ALL POWER CONTROLS.
- BATTERY SHOULD ALWAYS BE DISCONNECTED DURING REPLACEMENT OF ELECTRICAL COMPONENTS.
- KEEP ALL SUPPORT EQUIPMENT AND ATTACHMENTS STOWED IN THEIR PROPER PLACE.
- USE ONLY APPROVED, NONFLAMMABLE CLEANING SOLVENTS.

REVISION LOG

Original Issue	A - December 23, 2005
Revised	B - January 2, 2005
Revised	C - January 6, 2005
Revised	D - May 23, 2006
Revised	E - October 4, 2006
Revised	F - December 5, 2007
Revised	G - September 18, 2008
Revised	H - February 4, 2011
Revised	I - April 29, 2013
Revised	J - October 24, 2017
Revised	K - June 29, 2018 - Revised Covers

Go to Discount-Equipment.com to order your parts

TABLE OF CONTENTS

SUBJECT - SECTION, PARAGRAPH		PAGE NO.
SECTION	1- MACHINE SPECIFICATIONS	
1.1	CAPACITIES.....	1-2
	System Voltage	1-2
	Hydraulic System.....	1-2
	Drive Motor Torque Hub (Gear Oil).....	1-2
1.2	COMPONENT DATA.....	1-2
	Hydraulic Pump/Pump Motor Assembly	1-2
	Rear Wheel Drive Motors	1-2
	Batteries/Battery Charger.....	1-2
1.3	PERFORMANCE DATA.....	1-2
	Platform Capacity	1-2
	Maximum Horizontal Manual Side Force	1-2
	Platform Size.....	1-3
	Material Tray Size	1-3
	Platform Height (Fully Elevated)	1-3
	Platform Maximum (Working) Height	1-3
	Machine Height	1-3
	Machine Overall.....	1-3
	Platform Entry Height	1-3
	Machine Ground Clearance.....	1-3
	Machine Turning Radius (Outside)	1-3
1.4	SERIAL NUMBER PLATE LOCATIONS	1-3
1.5	TORQUE REQUIREMENTS.....	1-3
1.6	CYLINDER SPECIFICATIONS	1-3
1.7	LUBRICATION.....	1-3
	Hydraulic Oil.....	1-3
	Lubrication Specifications	1-4
1.8	TORQUE SPECIFICATIONS	1-5
SECTION	2 - GENERAL SERVICE INFORMATION	
2.1	MACHINE PREPARATION, INSPECTION, AND MAINTENANCE.....	2-1
	General	2-1
	Preparation, Inspection, and Maintenance	2-1
	Pre-Start Inspection	2-1
	Pre-Delivery Inspection and Frequent Inspection.....	2-1
	Annual Machine Inspection.....	2-1
	Preventative Maintenance.....	2-1
2.2	PREVENTIVE MAINTENANCE AND INSPECTION SCHEDULE.....	2-2
2.3	SERVICING AND MAINTENANCE GUIDELINES.....	2-5
	General	2-5
	Safety and Workmanship	2-5
	Cleanliness.....	2-5
	Components Removal and Installation	2-5
	Component Disassembly and Reassembly	2-5
	Pressure-Fit Parts.....	2-5
	Bearings	2-5
	Gaskets.....	2-6
	Bolt Usage and Torque Application	2-6
	Hydraulic Lines and Electrical Wiring.....	2-6
	Hydraulic System.....	2-6

TABLE OF CONTENTS

Lubrication and Servicing	2-6
Batteries	2-6
Mast Chain Inspection Procedure	2-6
2.4 LUBRICATION INFORMATION	2-8
Hydraulic System	2-8
Hydraulic Oil	2-8
Changing Hydraulic Oil	2-8
Lubrication Specifications	2-8

SECTION 3 - BASE COMPONENTS

3.1 BASE ASSEMBLY COMPONENTS	3-1
3.2 BASE FRAME COVERS	3-3
Hood (Carry Deck)	3-3
Hood (Carry Deck) Frame	3-3
Drive Motor Cover	3-4
Rear Bumper Cover	3-4
3.3 DRIVE AND CASTER WHEELS	3-5
Tire Wear and Damage	3-5
Wheel and Tire Replacement	3-5
Wheel Installation	3-5
(Front) Caster Wheel Installation	3-6
3.4 DRIVE/ELEVATION CUT-OUT SWITCH INSTALLATION	3-6
3.5 WHEEL DRIVE ASSEMBLY SERVICING	3-7
Roll and Leak Testing	3-7
Oil Type and Capacity	3-7
Drive Motor Brush Wear - Warning Indication	3-8
Wheel Drive Assembly Removal	3-8
Wheel Drive Main Components Disassembly	3-10
Replacing Drive Motor Brushes	3-11
Torque Hub Main Disassembly	3-12
Input Carrier Disassembly	3-13
Hub Disassembly	3-14
Spindle Disassembly	3-15
Spindle Sub-Assembly	3-16
Hub Sub-Assembly	3-17
Input Carrier Sub-Assembly	3-18
Main Torque Hub Sub-Assembly	3-19
Motor, Brake, and Torque Hub Assembly	3-20
3.6 PUMP MOTOR ASSEMBLY	3-21
General	3-21
Hydraulic Pressure Settings and Adjustment	3-21
Hydraulic Pressure Gauge Connection	3-22
After Filter Pressure Check	3-22
Pump Motor Assembly Removal	3-23
Pump Motor Assembly Installation	3-23
Motor/Brush Cover Removal	3-24
Brush Carrier Assembly Removal	3-25
Brush Assembly Removal	3-25
Tank Removal	3-25
Filter Screen Removal	3-26
Pump Removal	3-26
Pressure Adjust Valve Removal	3-26
Pressure Check Valve Removal	3-26
3.7 BATTERIES AND BATTERY CHARGER	3-27
Battery Condition Testing	3-27

Battery Replacement 3-27
 Battery Installation (2-12V) 3-27
 Battery Installation (4-6V)..... 3-28
 Battery Charge LED Indicator on Platform Control Console 3-29
 Battery Low Voltage Warning Indicators 3-29
 Battery Charging Status Indicators 3-30
 Battery Charger Maintenance..... 3-30
 Battery Charger Check/Change Charging Algorithm..... 3-31
 Battery Charger Removal/Installation 3-31

SECTION 4 - CONTROL COMPONENTS

4.1 CONTROL COMPONENTS OVERVIEW 4-1
 4.2 CONTROL COMPONENTS INSTALLATION 4-3
 Ground Control Module 4-3
 Traction Control Module Installation 4-4
 Platform Control Console Installation 4-4
 Platform Junction Box Installation 4-5
 Junction Box to Ground Control Harness Installation 4-5
 Platform Interlock Switch Circuit 4-6
 Component Electrical Connections 4-7
 4.3 GROUND CONTROL MODULE 4-9
 Cover Removal/Installation 4-10
 Power Selector/Emergency Stop Switch Installation 4-11
 4.4 GROUND CONTROL MODULE PROGRAMMING 4-12
 General 4-12
 Programming Levels 4-12
 Activating Programming Mode 4-12
 Entering Password 4-12
 Programming Mode Selection 4-13
 Selecting Programmable Item to Adjust..... 4-13
 Adjusting Programmable Setting 4-13
 Service Programming Mode - Level 2 4-14
 Operator Programming Mode - Level 3 4-14
 4.5 PLATFORM CONTROL CONSOLE..... 4-19
 General 4-19
 Display/Controller Module Electrical Connections 4-20
 Mounting Bracket 4-20
 Rear Cover 4-20
 Display/Controller Module 4-21
 Drive/Lift Mode Switch (Prior to SN 0130032507)..... 4-21
 Horn Button Switch 4-21
 Key Switch 4-21
 E-Stop/ShutDown Switch..... 4-22
 Joystick Assembly..... 4-22
 4.6 OBJECT DETECTION SYSTEM (IF EQUIPPED) 4-23
 Removal 4-23
 Installation..... 4-23

SECTION 5 - MAST COMPONENTS

5.1 MAST COMPONENTS OVERVIEW 5-1
 5.2 MAST COVER 5-2
 5.3 PLATFORM ASSEMBLY 5-2
 5.4 7 FOOT HEIGHT LIMIT SWITCH (IF EQUIPPED) 5-3
 5.5 MANUAL MATERIAL TRAY 5-3

TABLE OF CONTENTS

5.6	POWER TRAY DISASSEMBLY	5-4
	Covers and Tray Removal	5-4
	Electrical and Hydraulic Components Removal	5-6
	Pulley System Disassembly	5-7
	Power Tray Lift Cylinder.....	5-9
5.7	POWER TRAY INSTALLATION	5-10
	Pulley System Assembly	5-10
	Electrical and Hydraulic Components Installation	5-12
	Covers and Tray Installation.....	5-13
5.8	HYDRAULIC LINE DISCONNECT TOOL	5-13
	In-Line Style Fittings	5-14
	Angled-Style Fittings	5-15
5.9	MAST REMOVAL	5-16
	Mast Installation.....	5-16
5.10	MAST DISASSEMBLY	5-17
	Procedure.....	5-17
	Mast Section 4 (Platform Mount)	5-17
	Mast Section 3.....	5-17
	Mast Section 2.....	5-17
	Mast Section 1.....	5-17
5.11	CYLINDER DISASSEMBLY.....	5-18
	Lift Cylinder Component Inspection.....	5-19
	Cylinder Assembly.....	5-19
	Manual Descent Valve	5-20
	Remote Manual Descent (If Equipped)	5-20
5.12	MAST ASSEMBLY.....	5-21
	Mast Section 1.....	5-22
	Mast Section 2.....	5-22
	Mast Section 3.....	5-25
	Mast Section 4.....	5-27
5.13	MAST CHAINS AND SEQUENCING CABLES ADJUSTMENT	5-31
	Mast Chain/Cable Adjustment	5-31
	Sequencing Cable Adjustment.....	5-31
SECTION 6 - TROUBLESHOOTING		
6.1	GENERAL	6-1
6.2	TROUBLESHOOTING INFORMATION	6-1
6.3	HYDRAULIC CIRCUIT CHECKS	6-1
6.4	ELECTRICAL CIRCUIT CHECKS	6-1
	General	6-1
6.5	MULTIMETER BASICS	6-2
	Grounding	6-2
	Backprobing	6-2
	Min/Max	6-2
	Polarity	6-2
	Scale.....	6-2
	Voltage Measurement	6-3
	Resistance Measurement	6-3
	Continuity Measurement	6-4
	Current Measurement	6-4
	Continuity Measurement Over Long Distances	6-4
	Requirements	6-4
	Procedure.....	6-5

6.6	ELECTRICAL SWITCH TESTING	6-5
	Basic Check	6-5
	Limit Switches	6-6
	Automatic Switches	6-6
	Switch Wiring - Low Side, High Side.....	6-6
6.7	GROUND CONTROL MODULE LCD DISPLAY	6-7
6.8	SPECIFICATIONS FOR VARIOUS COMPONENTS.....	6-14
6.9	SPECIAL PIN EXTRACTOR TOOLS FOR ELECTRICAL CONNECTORS.....	6-14
6.10	FAULT CODE TROUBLESHOOTING TABLES.....	6-15
6.11	MAIN POWER CIRCUIT TROUBLESHOOTING.....	6-37
	Machine Will Not Power Up.....	6-37
6.12	MAST TROUBLESHOOTING.....	6-38
	Platform Will Not Lower Manually	6-38
	Platform Lift Up and Down Jerky.....	6-39
	Mast Noisy When Lifting And Lowering	6-40
	Platform (Mast) Won't Stay Elevated	6-41
	Platform (Mast) Descends Too Slowly	6-41
6.13	HYDRAULIC LEAK TROUBLESHOOTING	6-42
	Miscellaneous Hydraulic Leak Troubleshooting	6-42
6.14	BASE FRAME COMPONENTS TROUBLESHOOTING	6-42
	Caster Wheels Not Operating Freely	6-42
6.15	DRIVE SYSTEM TROUBLESHOOTING	6-43
	Won't Climb Grade	6-43
	Machine Drives in Opposite Direction.....	6-43
	Machine Won't Drive Straight.....	6-44
	Noise From Drive Assembly.....	6-45

LIST OF FIGURES

FIGURE NO.	TITLE	PAGE NO.
1-8	Torque Chart - SAE Fasteners (Sheet 1 of 5)	1-5
1-9	Torque Chart - SAE Fasteners (Sheet 2 of 5)	1-6
1-10	Torque Chart - SAE Fasteners (Sheet 3 of 5)	1-7
1-11	Torque Chart - METRIC Fasteners (Sheet 4 of 5)	1-8
1-12	Torque Chart - METRIC Fasteners (Sheet 5 of 5)	1-9
3-1.	Base Components (Prior to SN 0130032507)	3-1
3-2.	Base Components (SN 0130032507 to Present)	3-2
3-3.	Wheel Bolts Tightening Sequence	3-5
3-4.	Wheel Drive Assembly Installation (Right Side Shown)	3-9
3-5.	Drive Motor Disassembly	3-10
3-6.	Drive Motor Brush Holder Components	3-11
3-7.	Hydraulic Pressure Adjustment Screw	3-21
3-8.	Typical Hydraulic Pressure Gauge Installation	3-22
3-9.	Typical Hydraulic Pressure Gauge Installation	3-22
4-1.	Control Components Location (Prior to SN 0130032507)	4-1
4-2.	Control Components Location (SN 0130032507 to Present)	4-2
4-3.	Ground Control Module Installation	4-3
4-4.	Platform Interlock Switch Circuit (Prior to SN 0130032507)	4-6
4-5.	Platform Interlock Switch Circuit (SN 0130032507 to Present)	4-6
4-6.	Component Electrical Connections (2-12V Batteries)	4-7
4-7.	Component Electrical Connections (4-6V Batteries)	4-8
4-8.	Ground Control Module Components	4-9
4-9.	Platform Control Console Installation	4-19
4-10.	Object Detection System	4-23
4-10.	Relay Installation	4-23
5-1.	Mast Components	5-1
5-2.	Power Tray Roller Assembly	5-5
5-3.	Power Unit Components	5-6
5-4.	Pulley System Overview	5-8
5-5.	Push Type Hydraulic Line Removal	5-13
5-6.	Lift Cylinder Component Cross-Section	5-18
5-7.	Mast Section - Assembly Reference	5-21
5-8.	Platform Junction Box to Ground Control Station Wiring Harness	5-30
5-9.	Mast Chain and Sequence Cable Adjustment Components	5-32
6-1.	Voltage Measurement (DC)	6-3
6-2.	Resistance Measurement	6-3
6-3.	Continuity Measurement	6-4
6-4.	Current Measurement (DC)	6-4
6-5.	LCD Display Symbols	6-7
6-6.	Component Electrical Connections with 2-12V Batteries (Prior to SN 0130032507)	6-8
6-7.	Component Electrical Connections with 4-6V Batteries (SN 0130032507 to Present)	6-9
6-8.	Electrical Components Installation (with 2-12V Batteries)	6-46
6-9.	Electrical Components Installation (with 4-6V Batteries)	6-47
6-10.	Electrical Components Installation (SN 0130032507 to Present)	6-48
6-11.	Electrical Schematic - Sheet 1 of 2 (Prior to SN 0130032507)	6-50
6-12.	Electrical Schematic - Sheet 2 of 2 (Prior to SN 0130032507)	6-51
6-13.	Electrical Schematic - Sheet 1 of 4 (SN 0130032507 to Present)	6-52
6-14.	Electrical Schematic - Sheet 2 of 4 (SN 0130032507 to Present)	6-53
6-15.	Electrical Schematic - Sheet 3 of 4 (SN 0130032507 to Present)	6-54
6-16.	Electrical Schematic - Sheet 4 of 4 (SN 0130032507 to Present)	6-55
6-17.	Hydraulic Schematic	6-56
6-18.	Hydraulic Schematic -Power Tray (If Equipped)	6-57

LIST OF TABLES

TABLE NO.	TITLE	PAGE NO.
1-1	Machine Operating Specifications	1-1
1-2	Platform Maximum Capacity	1-2
1-3	Hydraulic Oil Operating Range	1-3
1-4.	Mobilfluid 424 Specs	1-3
1-5.	UCon Hydrolube HP-5046 Specs	1-3
1-6	Lubricant Key	1-4
1-7	Lubrication Intervals for Various Components	1-4
2-1	Maintenance and Inspection Requirements	2-2
2-2	Preventive Maintenance & Inspection Schedule	2-3
2-3	Chain Stretch Tolerance	2-6
3-1	Wheel Torque Chart	3-5
3-2	Battery Low Voltage Warning Indicators	3-29
4-1	Field Programmable Settings and Factory Preset (Prior to SN 0130032507)	4-15
4-2	Field Programmable Settings and Factory Preset (SN 0130032507 to Present)	4-17
6-1	LCD Display - Service Fault Code Conditions	6-10
6-2	Ohm Ratings for Various Components	6-14
6-3	Amperage Draw for Various Components	6-14
6-4	Special Pin Extractor Tools for Electrical Connectors	6-14
6-5	Machine In Drive Speed Cut-Back (Turtle) Mode All The Time	6-15
6-6	Obstruction Below Platform	6-15
6-7	Code 01 - Low Battery Voltage	6-16
6-8	Code 04 - Tilt Condition	6-17
6-9	Code 05 - Obstruction Sensor - No Communication	6-17
6-10	Code 07 - Left Drive Motor - Disconnected	6-18
6-11	Code 08 - Right Drive Motor Disconnected	6-18
6-12	Code 09 - Left Brake - Disconnected	6-19
6-13	Code 10 - Right Brake - Disconnected	6-19
6-14	Code 11 - Left Drive Motor - Short Circuit	6-20
6-15	Code 12 - Right Drive Motor - Short Circuit	6-20
6-16	Code 13 - Traction Module - In Fold Back	6-21
6-17	Code 14 - Pump Motor - Disconnected	6-21
6-18	Code 15 - Lift Down Valve - Disconnected	6-22
6-19	Code 16 - Lift Down Valve - Short Circuit	6-22
6-20	Code 17 - Ground Control Module - In Fold Back	6-23
6-21	Code 18 - Alarm - Short Circuit	6-23
6-22	Code 19 - Alarm - Disconnected	6-24
6-23	Code 20 - Beacon - Short Circuit	6-24
6-24	Code 21 - Beacon - Short Disconnected	6-25
6-25	Code 22 - Horn - Short Circuit	6-25
6-26	Code 23 - Horn - Disconnected	6-26
6-27	Code 24 - P1-Auxiliary #1 Circuit - Short Circuit	6-26
6-28	Code 25 - P1-Auxiliary #1 Circuit - Disconnected	6-27
6-29	Code 26 - P1-Auxiliary #2 - Short Circuit	6-27
6-30	Code 27 - P1-Auxiliary #2 - Disconnected	6-28
6-31	Code 30 - Traction Module - No Communication with Ground Control Module	6-29
6-32	Code 31 - Platform Control Console - No Communication with Ground Control Module	6-30
6-33	Code 32 - Pump Motor - Over Current	6-31
6-34	Code 34 - P2-Auxiliary #1 - Inhibit	6-31
6-35	Code 35 - P2-Auxiliary #1 - Tie-Down	6-32
6-36	Code 36 - Auxiliary #2 - Inhibit	6-32
6-37	Code 37 - Auxiliary #2 - Tie-Down	6-33
6-38	Codes (100 - 199) Ground Control Module - Fault Condition	6-34
6-39	Code (200 - 299) Platform Control Console - Fault Condition	6-35
6-40	Codes (300 - 399) Traction Control Module - Fault Condition	6-36
6-41	Machine Will Not Power UP	6-37

TABLE OF CONTENTS

6-42 Platform Will Not Lower Manually 6-38
6-43 Platform Lift Up and Down Jerky 6-39
6-44 Mast Noisy when Lifting and Lowering 6-40
6-45 Platform (Mast) Won't Stay Elevated 6-41
6-46 Platform (Mast) Descends Too Slowly 6-41
6-47 Hydraulic Leak Troubleshooting 6-42
6-48 Caster Wheels Not Operating Freely 6-42
6-49 Won't Climb Grade 6-43
6-50 Machine Drive in Opposite Direction 6-43
6-51 Machine Won't Drive Straight 6-44
6-52 Noise from Drive Assembly 6-45

Go to Discount-Equipment.com to order your parts

SECTION 1. MACHINE SPECIFICATIONS

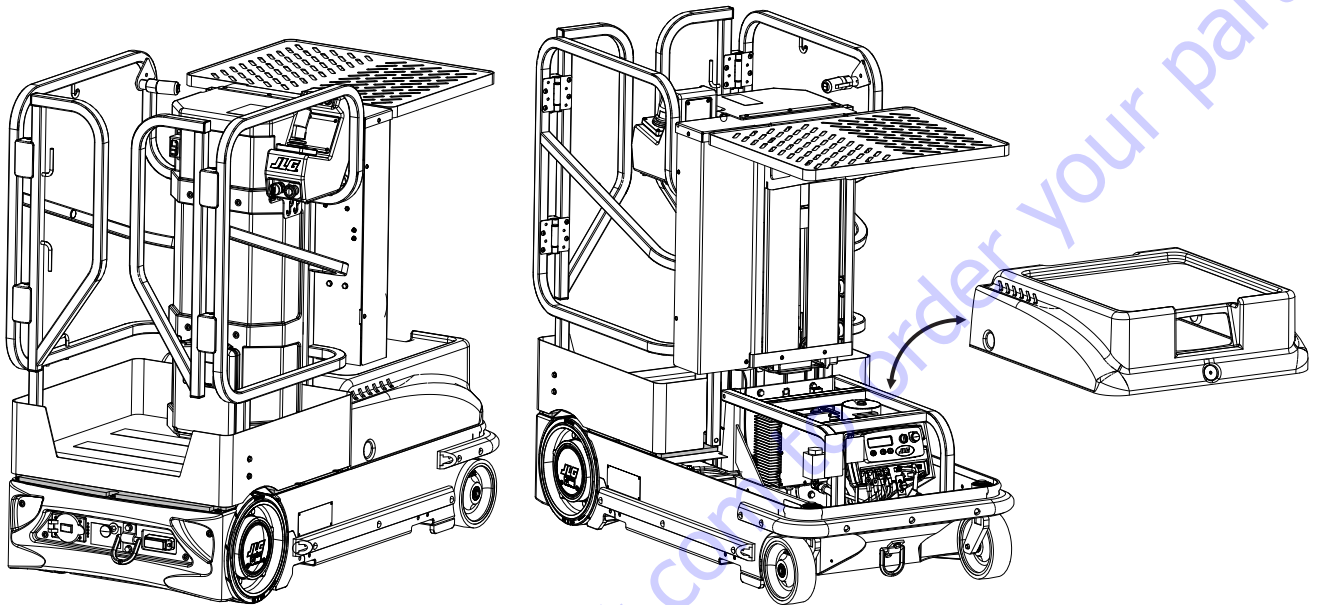

Table 1-1. Machine Operating Specifications

SPECIFICATIONS	10MSP
Maximum Occupants	1
Maximum Work Load (Capacity)	Refer to Table 1-2, Platform Maximum Capacity
Maximum Travel Grade (Gradeability) (Platform STOWED ONLY)	15% (8.5°)
Maximum Travel Grade (Side Slope) (Platform STOWED ONLY)	5°
Tilt Alarm Cut Out Limit (Any Direction) (Platform ELEVATED)	1.5°
Machine Height (Platform Stowed)	57 in (1.45 m)
Maximum Vertical Platform Height	Standard: 10 ft (3.05 m) with Optional Height Limiter: 7 ft (2.13 m)
Maximum Wheel Load (Per Wheel)	Rear: 575 lb - 86.6 PSI Front: 400 lb - 151.2 PSI
Maximum Drive Speeds (Operator Variable)	Min - Max: 0.5 - 3.4 mph (0.8 - 5.5 kph)* Platform Elevated: 0.5 mph (0.8 kph) * Machines from SN 0130032507 to present have a maximum drive speed of 5.0 mph (8 kph) when the platform is stowed.
Max. Platform Speeds (w/Max. Load)	Platform Up: 13 sec Platform Down: 9 - 13 sec
Gross Machine Weight (Machine + Maximum Capacity)	1950 lb (885 kg)

1.1 CAPACITIES

System Voltage

- 24 V DC

Hydraulic System

- 5 qts U.S. (4.7 L)

Drive Motor Torque Hub (Gear Oil)

- 10 oz (296 cc)

1.2 COMPONENT DATA

Hydraulic Pump/Pump Motor Assembly

- **Pump Motor** - 24 V DC motor, Standard Duty
- **Pump Displacement** - 0.098 cu. in./rev. (1.6cc/rev.)
- **Pump Output (Max.)** - 2.25 gpm @ 1400 psi @ 24 V and 105 A @ 43 centistrokes (200 SSU)
- **Reservoir Capacity** - 1 gal (3.78 L)

Rear Wheel Drive Motors

- **Drive Motors** - 24 Volt DC, Variable
- **Torque Hub** - 3500 in.lb. (395.5 Nm) - Continuous Output
7000 in.lb. (791 Nm) - Intermittent Output
30.68:1 Gear Ratio
- **Brakes** - Friction Disk - Spring Applied - Electrically Released

Batteries/Battery Charger

- **Batteries** - 6 V DC (4 in series @ 24 V)
12 V DC (2 in series @ 24 V) (if equipped)
- **Nominal Capacity** - 12 V - 100 Amp Hour @ 20 Hour
6 V - 210 Amp Hour @ 20 Hour
- **Type** - M2 Marine Combination (AGM)/Valve Regulated/
Leak Proof/NonCorrosive/Maintenance Free
- **Weight** -12V - 65.7 lb (29.8 kg) per battery
6V - 64 lb (29 kg) per battery

NOTICE

JLG MACHINES EQUIPPED WITH DELTA Q BATTERY CHARGERS ARE DESIGNED FOR THE BEST PERFORMANCE WITH OEM FACTORY APPROVED BATTERIES. APPROVED JLG REPLACEMENT BATTERIES ARE AVAILABLE THROUGH JLG'S AFTERMARKET PARTS DISTRIBUTION CENTERS OR JLG'S AFTERMARKET PROGRAMS. FOR ASSISTANCE WITH PROPER BATTERY REPLACEMENT, PLEASE CONTACT YOUR LOCAL JLG SUPPORT OFFICE.

BATTERIES APPROVED BY JLG HAVE BEEN TESTED FOR COMPATIBILITY WITH THE ALGORITHM PROGRAMMING OF THE DELTA Q BATTERY CHARGER TO OPTIMIZE BATTERY LIFE AND MACHINE CYCLE TIMES. THE USE OF NON APPROVED BATTERIES IN YOUR JLG EQUIPMENT MAY RESULT IN PERFORMANCE ISSUES OR BATTERY CHARGER FAULT CODES. JLG ASSUMES NO RESPONSIBILITY FOR SERVICE OR PERFORMANCE ISSUES ARISING FROM THE USE OF NON APPROVED BATTERIES.

- **Battery Charger** -
Microprocessor Controlled/SCR Circuit Monitor
120/240 Volt A.C. Selectable / 50/60 Hz input
24 volt, 20 amp output - with 2 amp finish
Reset Circuit Breaker
Automatic Charge Circuit
Plug Interlock Circuit

NOTE: These batteries require approximately five hours to fully charge when drained to 80% discharge (only the RED LEDS on platform console lit).

1.3 PERFORMANCE DATA

Platform Capacity

Table 1-2. Platform Maximum Capacity

SPECIFICATION	MAXIMUM CAPACITY				MAX. WIND SPEED
	Platform	Manual Material Tray	Powered Material Tray	CarryDeck	
ANSI/CSA					28mph (12m/s)
CE (Indoor Use Only)	350lb (160kg)	250lb (115kg)	200lb (90kg)	250lb (115kg)	0m/s
AUS (Indoor Use Only)					0m/s

NOTE: Distribute weight evenly in platform and material tray when loading. Reference the capacity decal located on the machines mast cover in the operators platform.

Maximum Horizontal Manual Side Force

Platform fully extended with maximum load

- **ANSI/CSA:** 100 lb (445 N)
- **CE/AUS/JPN:** 45 lb (200 N)

Platform Size

- 19.5 in x 27 in (49.5 cm x 68.5 cm)

Material Tray Size

- Manual Tray - 25.26 in x 28.26 in (64 cm x 72 cm)
- Power Tray - 21.89 in x 28.27 in (55.6 cm x 71.8 cm)

Platform Height (Fully Elevated)

- 10 ft (3.05 m) - Standard (to floor of platform)
- 7 ft (2.13 m) - w/ Height Limiter (if equipped) (to platform floor)

Platform Maximum (Working) Height

- 16 ft (4.92 m) (platform fully elevated + operator height)

Machine Height

- **Platform Elevated** - 13.74 ft (4.19 m) (top of platform rails)
- **Platform Stowed** - 57 in (1.45 m)

Machine Overall

- **Length** - 61 in (1.55 m)
- **Width** - 29.5 in (75 cm) - standard
32.5 in (82.5 cm) - with bumpers
35.0 in (89 cm) - with roller guides

Platform Entry Height

- 13.75 in (34.9 cm) (floor to platform floor)

Machine Ground Clearance

- **Front** - 0.872 in (22 mm)
- **Center** - 1.872 in (47.5 mm)
- **Rear** - 0.622 in (16 mm)

Machine Turning Radius (Outside)

- 106 in (269 cm)

1.4 SERIAL NUMBER PLATE LOCATIONS

The serial number is stamped into a nameplate affixed to the machine. Machines prior to SN 0130032507 may have a serial number plate located at either the front of the mast assembly near the amber beacon or on the base frame near the rear drive wheels. Machines from SN 0130032507 to present will have a serial number plate located on the base frame near the caster wheels.

1.5 TORQUE REQUIREMENTS

When maintenance becomes necessary or a fastener has loosened, refer to the applicable Torque Specification chart in this section of the manual to determine proper torque values for various size fasteners.

1.6 CYLINDER SPECIFICATIONS

DESCRIPTION	BORE	STROKE	ROD DIAMETER
Lift Cylinder	1.63 in (4.10 cm)	41.50 in (105.4 cm)	1.375 in (3.49 cm)

1.7 LUBRICATION

Hydraulic Oil

NOTE: Hydraulic oils must have anti-wear qualities at least to API Service Classification GL-3, and sufficient chemical stability for mobile hydraulic system service.

NOTE: Aside from JLG recommendations, it is not advisable to mix oils of different brands or types, as they may not contain the same required additives or be of comparable viscosities.

Table 1-3. Hydraulic Oil Operating Range

HYDRAULIC SYSTEM OPERATING TEMPERATURE RANGE	SAE VISCOSITY GRADE
+0°F to +180°F (-18°C to +83°C)	10W
+0°F to +210°F (-18°C to +99°C)	10W-20, 10W-30
+50°F to +210°F (+10°C to +99°C)	20W-20

Table 1-4. Mobilfluid 424 Specs

SAE Grade	10W30
Gravity, API	29.0
Density, Lb/Gal. 60°F	7.35
Pour Point, Max	-46°F (-43°C)
Flash Point, Min.	442°F (228°C)
Viscosity	
Brookfield, cP at -18°C	2700
at 40°C	55 cSt
at 100°C	9.3 cSt
Viscosity Index	152

Table 1-5. UCon Hydrolube HP-5046 Specs

pH	9.1
Specific Gravity, 20/20°F	1.082
Pour Point, °C(°F)	<-50(<58)
Appearance	Red Liquid
Viscosity	
at 0°C (32°F)	340cST(1600SUS)
at 40°C (104°F)	46cST(215SUS)
at 65°C (150°F)	22cST(106SUS)
Viscosity Index	170

Lubrication Specifications

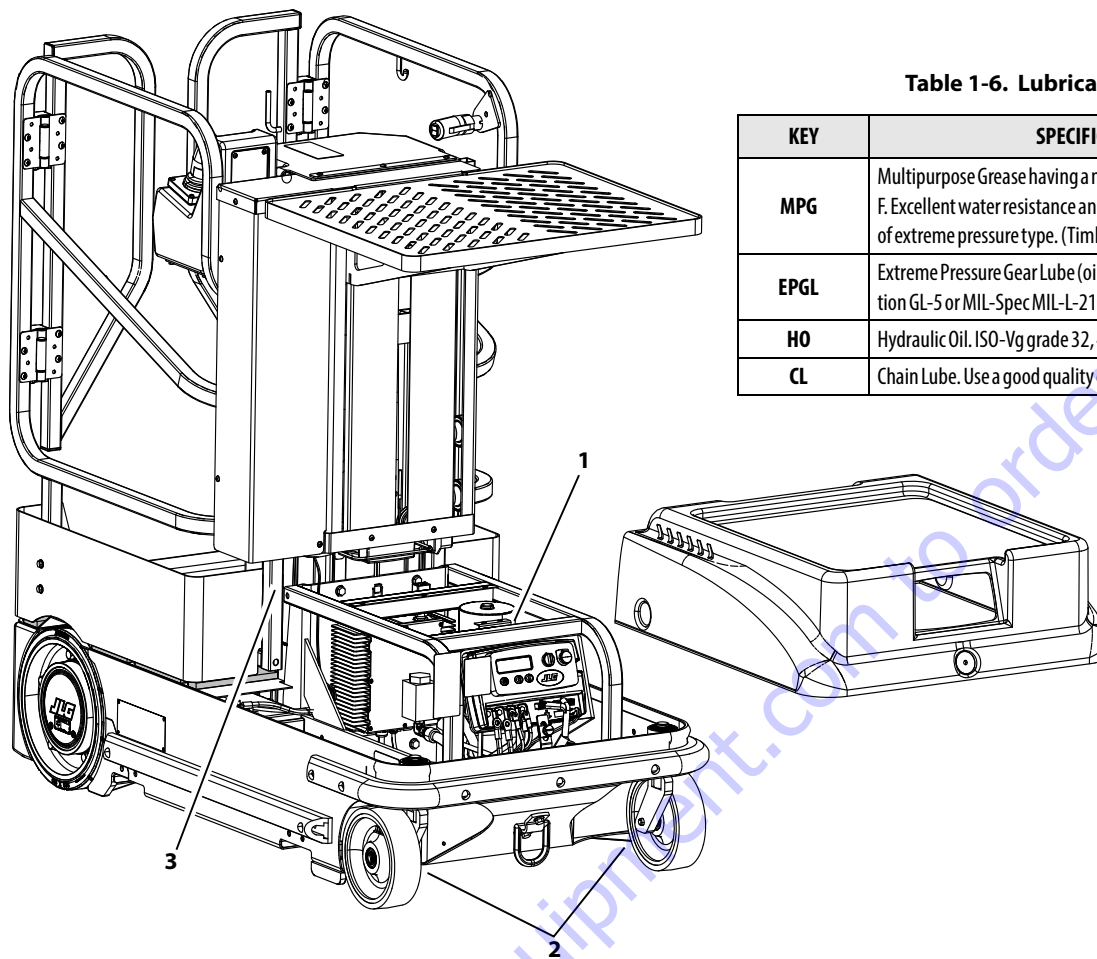

Table 1-6. Lubricant Key

KEY	SPECIFICATIONS
MPG	Multipurpose Grease having a minimum dripping point of 350° F. Excellent water resistance and adhesive qualities, and being of extreme pressure type. (Timken OK 40 pounds minimum.)
EPGL	Extreme Pressure Gear Lube (oil) meeting API service classification GL-5 or MIL-Spec MIL-L-2105.
HO	Hydraulic Oil. ISO-Vg grade 32, 46.
CL	Chain Lube. Use a good quality chain lubricant

Table 1-7. Lubrication Intervals for Various Components

ITEM	COMPONENT	NO/TYPE LUBE POINTS	LUBE/METHOD	INTERVAL (b)				COMMENTS
				3 MONTHS	6 MONTHS	1 YEAR	2 YEARS	
1	Hydraulic Oil	Fill To Full Line on Dipstick - 5 qt Reservoir	HO - Check Hyd. Oil Level HO - Change Hyd. Oil				✓	Check fluid level every day. Change hydraulic oil every 2 years. NOTE: Prior to checking hydraulic oil level, operate machine through one complete cycle of lift function (full up and down). Failure to do so will result in incorrect oil level reading on the hydraulic reservoir.
2	Swivel Raceways	—	MPG			✓		Upper: Permanently Sealed. Lower: Repack if Serviced.
3	Mast Chains	2 - Per Section	CL - Brush or Spray		✓			Inspect, lubricate if dry or rusting.

NOTE: Recommended lubricating intervals are based on normal use. If machine is subjected to severe operating conditions, such as a high number of cycles, location, corrosive/dirty environment, etc., user must adjust lubricating requirements accordingly.

Size		TPI	Bolt Dia	Tensile Stress Area	Clamp Load See Note 4	Magni Coating (Ref 4150701)*			Zinc Yellow Chromate Fasteners (Ref 4150707)*			
						Torque (Dry) K = .17	Torque (Locitite® 242™ or 271™ OR Vibra-TITE™ 111 or 140 OR Precoat 85®) K=0.16	Torque (Locitite® 262™ or Vibra-TITE™ 131) K=0.15	Clamp Load See Note 4	Torque (Dry) K = .20	Torque (Locitite® 242™ or 271™ OR Vibra-TITE™ 111 or 140 OR Precoat 85®) K=0.18	Torque (Locitite® 262™ or Vibra-TITE™ 131) K=0.15
		In	Sq In	LB	IN-LB	FT-LB	IN-LB	FT-LB	IN-LB	FT-LB	IN-LB	FT-LB
4	40	0.1120	0.00604									
	48	0.1120	0.00661									
6	32	0.1380	0.00909									
	40	0.1380	0.01015									
8	32	0.1640	0.01400									
	36	0.1640	0.01474									
10	24	0.1900	0.01750									
	32	0.1900	0.02000									
1/4	20	0.2500	0.0318	2860	122	114	13	114	143	129	15	
	28	0.2500	0.0364	3280	139	131	15	131	164	148	17	
5/16	18	0.3125	0.0524	4720	20	25	20	25	25	20	25	25
	24	0.3125	0.0580	5220	25	35	20	25	25	20	25	25
3/8	16	0.3750	0.0775	7000	35	50	35	50	45	40	55	50
	24	0.3750	0.0878	7900	40	55	40	55	50	45	60	50
7/16	14	0.4375	0.1063	9550	60	80	55	75	70	65	90	70
	20	0.4375	0.1187	10700	65	90	60	80	80	70	95	80
1/2	13	0.5000	0.1419	12750	90	120	85	115	105	95	130	110
	20	0.5000	0.1599	14400	100	135	95	130	120	110	150	120
9/16	12	0.5625	0.1820	16400	130	175	125	170	155	140	190	155
	18	0.5625	0.2030	18250	145	195	135	185	170	155	210	175
5/8	11	0.6250	0.2260	20350	180	245	170	230	203	190	260	220
	18	0.6250	0.2560	23000	205	280	190	260	240	215	290	245
3/4	10	0.7500	0.3340	30100	320	435	300	380	375	340	460	380
	16	0.7500	0.3730	33600	355	485	335	455	420	380	515	430
7/8	9	0.8750	0.4620	41600	515	700	485	660	605	570	740	620
	14	0.8750	0.5090	45800	570	775	535	730	670	600	815	680
1	8	1.0000	0.6060	51500	730	985	685	930	860	775	1055	875
	12	1.0000	0.6630	59700	845	1150	795	1080	995	915	1215	1015
1 1/8	7	1.1250	0.7630	68700	1095	1490	1030	1400	1290	1160	1580	1310
	12	1.1250	0.8560	77000	1225	1665	1155	1570	1445	1300	1770	1475
1 1/4	7	1.2500	0.9690	87200	1545	2100	1455	1980	1815	1635	2225	1855
	12	1.2500	1.0730	96600	1710	2325	1610	2190	2015	1770	2460	2055
1 3/8	6	1.3750	1.1550	104000	2025	2755	1905	2590	2385	2145	2915	2430
	12	1.3750	1.3150	118100	2300	3130	2165	2945	2705	2435	3310	2760
1 1/2	6	1.5000	1.4050	126500	2690	3660	2530	3440	3165	2845	3870	3225
	12	1.5000	1.5800	142200	3020	4105	2845	3870	3555	3200	4350	3625

NO. 5000059 REV. K

NOTES: 1. THESE TORQUE VALUES DO NOT APPLY TO CADMIUM PLATED FASTENERS
 2. ALL TORQUE VALUES ARE STATIC TORQUE MEASURED PER STANDARD AUDIT METHODS TOLERANCE = +10%
 *3. ASSEMBLY USES HARDENED WASHER OR FASTENER IS PLACED AGAINST PLATED STEEL OR RAW ALUMINUM
 4. CLAMP LOAD LISTED FOR SHCS IS SAME AS GRADE 8 OR CLASS 10.9 AND DOES NOT REPRESENT FULL STRENGTH CAPABILITY OF SHCS. IF HIGHER LOAD IS REQUIRED, ADDITIONAL TESTING IS REQUIRED.

Figure 1-10. Torque Chart - SAE Fasteners (Sheet 3 of 5)

Values for Zinc Yellow Chromate Fasteners (Ref 4150707)											
CLASS 8.8 METRIC (HEX/SOCKET HEAD) BOLTS CLASS 8 METRIC NUTS					CLASS 10.9 METRIC (HEX HEAD) BOLTS CLASS 10 METRIC NUTS CLASS 12.9 SOCKET HEAD CAP SCREWS M3 - M5*						
Size	PITCH	Tensile Stress Area	Clamp Load	Torque (Dry or Loctite® 263™)	Torque (Lub)	Torque (Loctite® 262™ OR VIBRA-TITE™ 131)	Torque (Loctite® 242™ or 271™ OR VIBRA-TITE™ 111 or 140)	Clamp Load	Torque (Dry or Loctite® 263™) K = 0.20	Torque (Lub OR Loctite® 242™ or 271™ OR VIBRA-TITE™ 111 or 140) K = 0.18	Torque (Loctite® 262™ OR VIBRA-TITE™ 131) K = 0.15
		Sq mm	KN	[N.m]	[N.m]	[N.m]	[N.m]	KN	[N.m]	[N.m]	[N.m]
3	0.5	5.03	2.19	1.3	1.0	1.2	1.4	3.13			
3.5	0.6	6.78	2.95	2.1	1.6	1.9	2.3	4.22			
4	0.7	8.78	3.82	3.1	2.3	2.8	3.4	5.47			
5	0.8	14.20	6.18	6.2	4.6	5.6	6.8	8.85			
6	1	20.10	8.74	11	7.9	9.4	12	12.5			
7	1	28.90	12.6	18	13	16	19	18.0	25	23	19
8	1.25	36.60	15.9	26	19	23	28	22.8	37	33	27
10	1.5	58.00	25.2	50	38	45	55	36.1	70	65	55
12	1.75	84.30	36.7	88	66	79	97	52.5	125	115	95
14	2	115	50.0	140	105	126	154	71.6	200	180	150
16	2	157	68.3	219	164	197	241	97.8	315	280	235
18	2.5	192	83.5	301	226	271	331	119.5	430	385	325
20	2.5	245	106.5	426	320	383	469	152.5	610	550	460
22	2.5	303	132.0	581	436	523	639	189.0	830	750	625
24	3	353	153.5	737	553	663	811	222.0	1065	960	800
27	3	459	199.5	1080	810	970	1130	286.0	1545	1390	1160
30	3.5	561	244.0	1460	1100	1320	1530	349.5	2095	1885	1575
33	3.5	694	302.0	1990	1490	1790	2090	432.5	2855	2570	2140
36	4	817	355.5	2560	1920	2300	2690	509.0	3665	3300	2750
42	4.5	1120	487.0	4090	3070	3680	4290	698.0	5865	5275	4395

NO. 500059 REV. K

NOTES: 1. THESE TORQUE VALUES DO NOT APPLY TO CADMIUM PLATED FASTENERS
 2. ALL TORQUE VALUES ARE STATIC TORQUE MEASURED PER STANDARD AUDIT METHODS TOLERANCE = ±10%
 *3. ASSEMBLY USES HARDENED WASHER OR FASTENER IS PLACED AGAINST PLATED STEEL OR RAW ALUMINUM
 4. CLAMP LOAD LISTED FOR SHCS IS SAME AS GRADE 8 OR CLASS 10.9 AND DOES NOT REPRESENT FULL STRENGTH CAPABILITY OF SHCS. IF HIGHER LOAD IS REQUIRED, ADDITIONAL TESTING IS REQUIRED.

Figure 1-11. Torque Chart - METRIC Fasteners (Sheet 4 of 5)

Values for Magni Coated Fasteners (Ref 4150701)										
CLASS 8.8 METRIC (HEX/SOCKET HEAD) BOLTS CLASS 8 METRIC NUTS					CLASS 10.9 METRIC (HEX HEAD) BOLTS CLASS 10 METRIC NUTS CLASS 12.9 SOCKET HEAD CAP SCREWS M6 AND ABOVE*					
Size	PITCH	Tensile Stress Area	Clamp Load	Torque (Dry or Loctite® 263™) K=0.17	Torque (Loctite® 262™ OR Vibra-TITE™ 131) K=0.16	Torque (Loctite® 242™ or 271™ OR Vibra-TITE™ 111 or 140) K=0.15	Clamp Load	Torque (Dry or Loctite® 263™) K = 0.17	Torque (Lub OR Loctite® 242™ or 271™ OR Vibra-TITE™ 111 or 140) K= 0.16	Torque (Loctite® 262™ OR Vibra-TITE™ 131) K=0.15
		Sq mm	KN	[N.m]	[N.m]	[N.m]	KN	[N.m]	[N.m]	[N.m]
3	0.5	5.03	2.19	1.1	1.1	1.0	3.13			
3.5	0.6	6.78	2.95	1.8	1.7	1.5	4.22			
4	0.7	8.78	3.82	2.6	2.4	2.3	5.47			
5	0.8	14.20	6.18	5.3	4.9	4.6	8.85			
6	1	20.10	8.74	9	8.4	7.9	12.5	13	12	11
7	1	28.90	12.6	15	14	13	18.0	21	20	19
8	1.25	36.60	15.9	22	20	19	22.8	31	29	27
10	1.5	58.00	25.2	43	40	38	36.1	61	58	55
12	1.75	84.30	36.7	75	70	66	52.5	105	100	95
14	2	115	50.0	119	110	105	71.6	170	160	150
16	2	157	68.3	186	175	165	97.8	265	250	235
18	2.5	192	83.5	256	240	225	119.5	365	345	325
20	2.5	245	106.5	362	340	320	152.5	520	490	460
22	2.5	303	132.0	494	465	435	189.0	705	665	625
24	3	353	153.5	627	590	555	222.0	905	850	800
27	3	459	199.5	916	860	810	286.0	1315	1235	1160
30	3.5	561	244.0	1245	1170	1100	349.5	1780	1680	1575
33	3.5	694	302.0	1694	1595	1495	432.5	2425	2285	2140
36	4	817	355.5	2176	2050	1920	509.0	3115	2930	2750
42	4.5	1120	487.0	3477	3275	3070	698.0	4985	4690	4395

NOTES: 1. THESE TORQUE VALUES DO NOT APPLY TO CADMIUM PLATED FASTENERS

2. ALL TORQUE VALUES ARE STATIC TORQUE MEASURED PER STANDARD AUDIT METHODS. TOLERANCE = ±10%

*3. ASSEMBLY USES HARDENED WASHER OR FASTENER IS PLACED AGAINST PLATED STEEL OR RAW ALUMINUM

4. CLAMP LOAD LISTED FOR SHCS IS SAME AS GRADE 8 OR CLASS 10.9 AND DOES NOT REPRESENT FULL STRENGTH CAPABILITY OF SHCS. IF HIGHER LOAD IS REQUIRED, ADDITIONAL TESTING IS REQUIRED.

NO. 500059 REV. K

Figure 1-12. Torque Chart - METRIC Fasteners (Sheet 5 of 5)

PARTS FINDER

**Search Website
by Part Number**



**Search Manual
Library For Parts
Manual & Lookup Part
Numbers – Purchase
or Request Quote**

Search Manuals

Enter your information to search for manuals and parts.

* Brand:

* Model:

* Serial:

* Part Number:

SEARCH

**Can't Find Part or
Manual? Request Help
by Manufacturer,
Model & Description**

Parts Order Form

Please fill in the following information:

Manufacturer:

Model:

Description:

Quantity:

Part Number:

Part Name:

Part Description:

Part Location:

Part Condition:

Part Status:

Part Color:

Part Material:

Part Weight:

Part Dimensions:

Part Price:

Part Notes:

Submit

Discount-Equipment.com is your online resource for quality parts & equipment.

Florida: **561-964-4949** Outside Florida TOLL FREE: **877-690-3101**

Need parts?

Click on this link: <http://www.discount-equipment.com/category/5443-parts/> and choose one of the options to help get the right parts and equipment you are looking for. Please have the machine model and serial number available in order to help us get you the correct parts. If you don't find the part on the website or on one of the online manuals, please fill out the request form and one of our experienced staff members will get back to you with a quote for the right part that your machine needs.

We sell worldwide for the brands: Genie, Terex, JLG, MultiQuip, Mikasa, Essick, Whiteman, Mayco, Toro Stone, Diamond Products, Generac Magnum, Airman, Haulotte, Barreto, Power Blanket, Nifty Lift, Atlas Copco, Chicago Pneumatic, Allmand, Miller Curber, Skyjack, Lull, Skytrak, Tsurumi, Husquvarna Target, , Stow, Wacker, Sakai, Mi-T- M, Sullair, Basic, Dynapac, MBW, Weber, Bartell, Bennar Newman, Haulotte, Ditch Runner, Menegotti, Morrison, Contec, Buddy, Crown, Edco, Wyco, Bomag, Laymor, Barreto, EZ Trench, Bil-Jax, F.S. Curtis, Gehl Pavers, Heli, Honda, ICS/PowerGrit, IHI, Partner, Imer, Clipper, MMD, Koshin, Rice, CH&E, General Equipment, ,AMida, Coleman, NAC, Gradall, Square Shooter, Kent, Stanley, Tamco, Toku, Hatz, Kohler, Robin, Wisconsin, Northrock, Oztec, Toker TK, Rol-Air, Small Line, Wanco, Yanmar

SECTION 2. GENERAL SERVICE INFORMATION

2.1 MACHINE PREPARATION, INSPECTION, AND MAINTENANCE

General

This section provides the necessary information needed by those personnel that are responsible to place the machine in operation readiness and maintain its safe operating condition. For maximum service life and safe operation, ensure that all the necessary inspections and maintenance have been completed before placing the machine into service. With proper care, maintenance, and inspections performed per JLG's recommendations with any and all discrepancies corrected, this product will be fit for continued use.

Preparation, Inspection, and Maintenance

It is important to establish and conform to a comprehensive inspection and preventive maintenance program. The following table outlines the periodic machine inspections and maintenance recommended by JLG Industries, Inc. Consult your national, regional, or local regulations for further requirements for aerial work platforms. The frequency of inspections and maintenance must be increased as environment, severity and frequency of usage requires.

Pre-Start Inspection

It is the User's or Operator's primary responsibility to perform a Pre-Start Inspection of the machine prior to use daily or at each change of operator. Reference the Operation and Safety Manual for completion procedures for the Pre-Start Inspection. The Operation and Safety Manual must be read in its entirety and understood prior to performing the Pre-Start Inspection.

Pre-Delivery Inspection and Frequent Inspection

The Pre-Delivery Inspection and Frequent Inspection shall be performed by a qualified JLG equipment mechanic. JLG Industries, Inc. recognizes a qualified JLG equipment mechanic as a person who, by possession of a recognized degree, certificate, extensive knowledge, training, or experience, has successfully demonstrated the ability and proficiency to service, repair, and maintain the subject JLG product model.

The Pre-Delivery Inspection and Frequent Inspection procedures are performed in the same manner, but at different times. The Pre-Delivery Inspection shall be performed prior to each sale, lease, or rental delivery. The Frequent Inspection shall be accomplished for each machine in service for 3 months or 150 hours (whichever comes first); out of service for a period of more than 3 months; or when purchased used. The frequency of this inspection must be increased as environment, severity and frequency of usage requires.

Reference the JLG Pre-Delivery and Frequent Inspection Form and the Inspection and Preventative Maintenance Schedule for items requiring inspection during the performance of these inspections. Reference the appropriate areas of this manual for servicing and maintenance procedures.

Annual Machine Inspection

JLG recommends that the Annual Machine Inspection be performed by a Factory-Trained Service Technician on an annual basis, no later than thirteen months from the date of the prior Annual Machine Inspection. JLG Industries, Inc. recognizes a Factory-Trained Service Technician as a person who has successfully completed the JLG Service Training School for the subject JLG product model. Reference the machine Service and Maintenance Manual and appropriate JLG inspection form for performance of this inspection.

Reference the JLG Annual Machine Inspection Form and the Inspection and Preventative Maintenance Schedule for items requiring inspection during the performance of this inspection. Reference the appropriate areas of this manual for servicing and maintenance procedures.

For the purpose of receiving safety-related bulletins, it is important that JLG Industries, Inc. has updated ownership information for each machine. When performing each Annual Machine Inspection, notify JLG Industries, Inc. of the current machine ownership.

Preventative Maintenance

In conjunction with the specified inspections, maintenance shall be performed by a qualified JLG equipment mechanic. JLG Industries, Inc. recognizes a qualified JLG equipment mechanic as a person who, by possession of a recognized degree, certificate, extensive knowledge, training, or experience, has successfully demonstrated the ability and proficiency to service, repair, and maintain the subject JLG product model.

Reference the Preventive Maintenance Schedule and the appropriate areas of this manual for servicing and maintenance procedures. The frequency of service and maintenance must be increased as environment, severity and frequency of usage requires.

Table 2-1. Maintenance and Inspection Requirements

TYPE	FREQUENCY	PRIMARY RESPONSIBILITY	SERVICE QUALIFICATION	REFERENCE
Pre-Start Inspection	Prior to use each day; or at each Operator change	User or Operator	User or Operator	Operation and Safety Manual
Pre-Delivery Inspection	Prior to each sale, lease, or rental delivery	Owner, Dealer, or User	Qualified JLG Mechanic	Service and Maintenance Manual and applicable JLG inspection form
Frequent Inspection	In service for 3 months or 150 hours, whichever comes first; or Out of service for a period of more than 3 months; or Purchased used	Owner, Dealer, or User	Qualified JLG Mechanic	Service and Maintenance Manual and applicable JLG inspection form
Annual Machine Inspection	Annually, no later than 13 months from the date of the prior inspection	Owner, Dealer, or User	Factory-Trained Service Technician (Recommended)	Service and Maintenance Manual and applicable JLG inspection form
Preventative Maintenance	At intervals as specified in the Service and Maintenance Manual	Owner, Dealer, or User	Qualified JLG Mechanic	Service and Maintenance Manual

2.2 PREVENTIVE MAINTENANCE AND INSPECTION SCHEDULE

The preventive maintenance and inspection checks are listed and defined in the following table. This table is divided into two basic parts, the "AREA" to be inspected and the "INTERVAL" at which the inspection is to take place. Under the "AREA" portion of the table, the various systems along with the components that make up that system are listed. The "INTERVAL" portion of the table is divided into five columns representing the various inspection time periods. The numbers listed within the interval column represent the applicable inspection code for which that component is to be checked.

The checks and services listed in this schedule are not intended to replace any local or regional regulations that may pertain to this type of equipment nor should the lists be considered as all inclusive. Variances in interval times may occur due to climate and/or conditions and depending on the location and use of the machine.

Maintenance and Inspection Table Codes

1. Check for proper and secure installation.
2. Visual inspection for damage, cracks, distortion, or excessive wear.
3. Check for proper adjustment.
4. Check for cracked or broken welds.
5. Operates properly.
6. Returns to neutral or "off" position when released.
7. Clean and free of debris.
8. Interlocks function properly.
9. Check for signs of leakage.

10. Decals installed and legible.
11. Check for proper fluid level.
12. Check for chafing and proper routing.
13. Check for proper tolerances.
14. Properly lubricated.
15. Torqued to proper specification.
16. No gouges, excessive wear, or cords showing.
17. Properly inflated and seated around rim.
18. Proper and authorized components.
19. Fully charged.
20. No loose connections, corrosion, or abrasions.
21. Verify.
22. Perform.
23. Sealed properly.
24. Overrides Platform controls.
25. Inspected per Service and Maintenance Manual.
26. No loose or missing parts.

Table 2-2.Preventive Maintenance & Inspection Schedule

AREA ON MACHINE	INTERVAL	
	PRE-DELIVERY (a) OR FREQUENT (b) INSPECTION	ANNUAL (c) (YEARLY) INSPECTION
MAST/PLATFORM ASSEMBLIES		
Mast Sections	2	2,5
Chain Systems	3,14	2,14,25
Cable Systems	3	25
Sequence Cable Systems	3	1,2
Mast Covers	1	1
Sheave Systems	1,2	1,2
Platform	1	1
Material Tray	2,5	2,5
Guard Rails	1,2,26	2
Gate, Gate Alarm (If Equipped)	5,8	5,8
Floor Pan	2	2
All Nuts, Bolts, Pins, Shafts, Shields, Bearings, Wear Pads, and Locking Devices	1,2,26	1,2,26
Lanyard Anchorage Point	1,4	1,4
Power Material Tray (If Equipped)	1,5	1,5
BASE ASSEMBLY		
Hood and Covers Installation	1,7	1,7
Static Strap	1	1
Drive and Caster Wheels	1,5	1,5
Pot Hole Protection System	5	5
Bubble Level (If Equipped)	1,2,7	1,2,7
Brake Release Cable (If Equipped)	5	5
Torque Hub Assembly*	—	—
Drive Motor Brushes**	—	—
FUNCTIONS/CONTROLS		
Platform Controls	5,6	5,6
Ground Controls	5,6,24	5,6,24
Function Control Locks, Guards, or Detents	5	5
Function Enable System	5	5
Emergency Stop Switches (Ground & Platform)	5	5
Function Limit or Cutout Switch System	5	5
Brake Release	5	5
Manual Descent	5	5
Touch Pad (If Equipped)	5,7	5,7
Drive/Lift Mode Selector Switch (If Equipped)	5	5
Control Enclosure and Protective Boot/Guards	2	2
Remote Manual Decent (If Equipped)	5	5
Object Detection System (If Equipped)	5	5
Platform Gate Alarm (If Equipped)	5	5
POWER SYSTEM		
Battery Fluid Level	11	11
Motors	2	2
Electrical Connections	20	20

SECTION 2 - GENERAL SERVICE INFORMATION

Table 2-2. Preventive Maintenance & Inspection Schedule (Continued)

AREA ON MACHINE	INTERVAL	
	PRE-DELIVERY (a) OR FREQUENT (b) INSPECTION	ANNUAL (c) (YEARLY) INSPECTION
Batteries	1,20	1,20
Battery Charger	1,5,20	5,20
HYDRAULIC SYSTEM		
Hydraulic Pump	1,2,9	1,2,9
Hydraulic Cylinder	2,9	2,9
Cylinder Attachment Pins and Pin Retainers	1,2	1,2
Hydraulic Hoses, Lines, and Fittings	1,9	1,9
Hydraulic Reservoir, Cap, and Breather	5,7	5,7
Hydraulic Filter	9	25
Hydraulic Fluid***	11	11
Electrical Connections	20	20
Instruments, Gauges, Switches, Lights, Horn	5	5
Control Valves	2,5,9	2,5,9
Hydraulic Pressures		3
MANUALS/DECALS		
Operation & Safety Manual in Storage Box	21	21
ANSI /SIA & AEM Handbooks in Storage Box	21	21
Capacity Decals Installed, Secure, Legible	10,21	10,21
All Decals/Placards Installed, Secure, Legible	10,21	10,21
GENERAL		
Annual Machine Inspection Due		21,22
No Unauthorized Modifications or Additions	21	21
All Relevant Safety Publications Incorporated	21,22	21,22
General Structural Condition and Welds	2,4	2,4
Grease and Lubricate to Specifications	22	22
Function Test of All Systems	22	22
Paint and Appearance	7	7
Notify JLG of change in Machine Ownership	22	22
* Change only when serviced, fill half full.		
** Replace after system brush wear indicator warning is activated.		
*** Drain and refill with fresh hydraulic fluid every two years.		
Footnotes: (a) Prior to each sale, lease, or delivery		
(b) In service for 3 months; or Out of service for 3 months or more; or Purchased used		
(c) Annually, no later than 13 months from the date of the prior inspection		

2.3 SERVICING AND MAINTENANCE GUIDELINES

General

The following information is provided to assist personnel in the use and application of servicing and maintenance procedures contained in this chapter.

Safety and Workmanship

Personnel safety, and that of others, is the first consideration when engaging in the maintenance of equipment. Always be conscious of component weight. Never attempt to move heavy parts without the aid of a mechanical device. Do not allow heavy objects to rest in an unstable position. When raising a portion of the equipment, ensure that adequate support is provided.

⚠ WARNING

NEVER WORK UNDER AN ELEVATED PLATFORM UNTIL PLATFORM HAS BEEN SAFELY RESTRAINED FROM ANY MOVEMENT BY BLOCKING OR OVERHEAD SLING.

Cleanliness

1. The most important single item in preserving the long service life of a machine is to keep dirt and foreign materials out of vital components. Precautions have been taken to safeguard against this. Shields, covers, seals, and filters are provided to keep the wheel bearings, mast sections and oil supply clean; however, these items must be maintained on a scheduled basis in order to function properly.

NOTICE

IT IS GOOD PRACTICE TO AVOID PRESSURE-WASHING ELECTRICAL/ELECTRONIC COMPONENTS. IN THE EVENT PRESSURE-WASHING THE MACHINE IS NEEDED, ENSURE THE MACHINE IS SHUT DOWN BEFORE PRESSURE-WASHING. SHOULD PRESSURE WASHING BE UTILIZED TO WASH AREAS CONTAINING ELECTRICAL/ELECTRONIC COMPONENTS, JLG INDUSTRIES, INC. RECOMMENDS A MAXIMUM PRESSURE OF 750 PSI (52 BAR) AT A MINIMUM DISTANCE OF 12 INCHES (30.5 CM) AWAY FROM THESE COMPONENTS. IF ELECTRICAL/ELECTRONIC COMPONENTS ARE SPRAYED, SPRAYING MUST NOT BE DIRECT AND BE FOR BRIEF TIME PERIODS TO AVOID HEAVY SATURATION.

2. At any time when oil lines are disconnected, clear adjacent areas as well as the openings and fittings themselves. As soon as a line or component is disconnected, cap or cover all openings to prevent entry of foreign matter.
3. Clean and inspect all parts during servicing or maintenance, and assure that all passages and openings are unobstructed. Cover all parts to keep them clean. Be sure all parts are clean before they are installed. New parts should remain in their containers until they are ready to be used.

Components Removal and Installation

1. Use adjustable lifting devices, whenever possible, if mechanical assistance is required. All slings (chains, cables, etc.) should be parallel to each other and as near perpendicular as possible to top of part being lifted.
2. Should it be necessary to remove a component on an angle, keep in mind that the capacity of an eyebolt or similar bracket lessens, as the angle between the supporting structure and the component becomes less than 90 degrees.
3. If a part resists removal, check to see whether all nuts, bolts, cables, brackets, wiring, etc., have been removed and that no adjacent parts are interfering.

Component Disassembly and Reassembly

When disassembling or reassembling a component, complete the procedural steps in sequence. Do not partially disassemble or assemble one part, then start on another. Always recheck work to ensure nothing has been overlooked. Do not make any adjustments, other than those recommended, without obtaining proper approval.

Pressure-Fit Parts

When assembling pressure-fit parts, use an "anti-seize" or molybdenum disulfide base compound to lubricate the mating surface.

Bearings

1. When a bearing is removed, cover it to keep out dirt and abrasives. Clean bearings in nonflammable cleaning solvent and allow to drip dry. Compressed air can be used but do not spin the bearing.
2. Discard bearings if the races and balls (or rollers) are pitted, scored, or burned.
3. If bearing is found to be serviceable, apply a light coat of oil and wrap it in clean (waxed) paper. Do not unwrap reusable or new bearings until they are ready to install.
4. Lubricate new or used serviceable bearings before installation. When pressing a bearing into a retainer or bore, apply pressure to the outer race. If the bearing is to be installed on a shaft, apply pressure to the inner race.

Gaskets

Check that holes in gaskets align with openings in the mating parts. If it becomes necessary to hand-fabricate a gasket, use gasket material or stock of equivalent material and thickness. Be sure to cut holes in the right location, as blank gaskets can cause serious system damage.

Bolt Usage and Torque Application

1. Self-locking fasteners, such as nylon insert and thread deforming locknuts, are not intended to be reinstalled after removal. Always use new replacement hardware when installing locking fasteners.
2. Use bolts of proper length. A bolt which is too long will bottom before the head is tight against its related part. If a bolt is too short, there will not be enough thread area to engage and hold the part properly. When replacing bolts, use only those having the same specifications of the original, or one which is equivalent.
3. Unless specific torque requirements are given within the text, standard torque values should be used on heat-treated bolts, studs, and steel nuts, in accordance with recommended shop practices. (Refer to the Torque Chart in Section 1.)

Hydraulic Lines and Electrical Wiring

Clearly mark or tag hydraulic lines and electrical wiring, as well as their receptacles, when disconnecting or removing them from the unit. This will ensure that they are correctly reinstalled.

Hydraulic System

1. Keep the system clean. If evidence of metal or rubber particles is found in the hydraulic system, drain and flush the entire system.
2. Disassemble and reassemble parts on clean work surface. Clean all metal parts with non-flammable cleaning solvent. Lubricate components, as required, to aid assembly.

Lubrication and Servicing

Service applicable components with the amount, type, and grade of lubricant recommended in this manual, at the specified intervals. When recommended lubricants are not available, consult a local supplier for an equivalent that meets or exceeds the specifications listed.

Batteries

Clean batteries using a non-metallic brush and a solution of baking soda and water. Rinse with clean water. After cleaning, thoroughly dry batteries and coat terminals with an anti-corrosion compound.

Mast Chain Inspection Procedure

Inspect mast chains for the following conditions:

- **Wear:** Always inspect that segment of chain that operates over a sheave. As the chain flexes over the sheaves, joints and plate edges very gradually wear. Chain "stretch" can be measured using a manufacturers wear scale or steel tape. When chains have elongated 3% they must be removed and replaced (refer to Table 2-3). Peening and wear of chain plate edges are caused by sliding over a chain worn contact face of a sheave, or unusually heavy loads. All of the above require replacement of chain and correction of the cause.

Table 2-3.Chain Stretch Tolerance

Chain Size	Pin to Pin Measurement	Allowable Stretch
.50" pitch	12" or 24 pitches	.24"/12" span
.625" pitch	15" or 24 pitches	.30"/15" span

Chain side wear, noticeable when pin heads and outside plates show a definite wear pattern, is caused by misalignment of the sheave/chain anchors and must be corrected promptly. Do not repair chains; if a section of chain is damaged, replace the entire chain set.

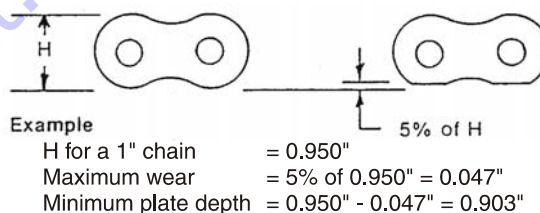

- **Rust and Corrosion:** Rust and corrosion will cause a major reduction in the load carrying capacity of the chain, because these are primary reasons for side plate cracking. The initial lubrication at the factory is applied in a hot dip tank to assure full penetration into the joint. Do not steam clean or degrease chains. At time of chain installation, factory lube must be supplemented by a maintenance program to provide a film of oil on the chains at all times.

If chains are corroded, they must be inspected, especially the outside plates, for cracks in-line with the pins. If cracks are found, replace the chain; if no cracks are discovered, lubricate the chains by dipping in heated oil, and reinstall on the machine. Keep chains lubricated.

- **Fatigue Cracks:** Fatigue is a phenomenon that affects most metals and is the most common cause of chain plate failures. Fatigue cracks are found through the link holes, perpendicular (90 degrees) from the pin in-line position. Inspect chains carefully after long time use and heavy loading for this type of crack. If any cracks are discovered, replace all chains, as seemingly sound plates are on the verge of cracking. Fatigue and ultimate strength failures on JLG Lifts are incurred as a result of severe abuse as design specs are well within the rated lifting capacity of these chains.

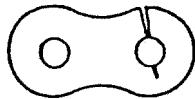

- **Tight Joints:** All joints in the leaf chain should flex freely. On leaf chain, tight joints are usually caused by rust/corrosion, or the inside plates "walking" off the bushing. Limber up rusty/corroded chains (after inspecting carefully) with a heavy application of oil (preferably a hot oil dip). Tap inside "walking" plates inward; if "walking" persists, replace the chain. This type of problem is accelerated by poor lubrication maintenance practice, and most tight joint chains have been operated with little or no lubrication. Tight joints on leaf chain are generally caused by:
 - a. Bent pins or plates.
 - b. Rusty joints.
 - c. Peened plate edges.

Oil rusty chains, and replace chains with bent or peened chain components. Keep chains lubricated.

TIGHT JOINTS



- **Protruding or Turned Pins:** Chains operating with inadequate lube generate tremendous friction between the pin and plates (pin and bushing on leaf chain). In extreme cases, this frictional torque can actually turn the pins in the outside press-fit plates. Inspect for turned pins, which can be easily spotted as the "V" flats on the pin heads are no longer in line. Replace all chains showing evidence of turned or protruding pins. Keep chains lubricated.

- **Stress Corrosion Cracking:** The outside link plates, which are heavily press-fitted to the pins, are particularly susceptible to stress corrosion cracking. Like fatigue cracks, these initiate at the point of highest stress (aperture) but tend to extend in an arc-like path, often parallel to the rolling grain of the material.

ABNORMAL PROTRUSION OR TURNED PINS

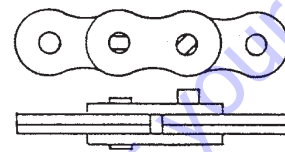

Also, more than one crack can often appear on a link plate. In addition to rusting, this condition can be caused by exposure to an acidic or caustic medium or atmosphere. Stress corrosion is an environmentally assisted failure. Two conditions must be present: corrosive agent and static stress.

ARC-LIKE CRACKED PLATES (STRESS CORROSION)

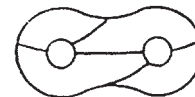

In the chain, static stress is present at the aperture due to the press fit pin. No cycle motion is required and the plates can crack during idle periods. The reactions of many chemical agents (such as battery acid fumes) with hardened metals liberate hydrogen which attacks and weakens the metal grain structure.

- **Chain Anchors and Sheaves:** An inspection of the chain must include a close examination of chain anchors and sheaves. Check chain anchors for wear breakage and misalignment. Anchors with worn or broken fingers should be replaced. They should also be adjusted to eliminate twisting the chain for an even load distribution.

Inspect the sheaves, sheave bearings, sheave grooves and pins for extreme wear, replace as necessary. A worn sheave can mean several problems, as follows:

- a. Chains too tight.
- b. Sheave bearings/pin bad.
- c. Bent/misaligned chains.

2.4 LUBRICATION INFORMATION

Hydraulic System

1. The primary enemy of a hydraulic system is contamination. Contaminants enter the system by various means, e.g., using inadequate hydraulic oil, allowing moisture, grease, filings, sealing components, sand, etc., to enter when performing maintenance, or by permitting the pump to cavitate due to insufficient system warm-up or leaks in the pump supply.
2. The design and manufacturing tolerances of the component working parts are very close, therefore, even the smallest amount of dirt or foreign matter entering a system can cause wear or damage to the components and generally results in faulty operation. Every precaution must be taken to keep hydraulic oil clean, including reserve oil in storage. Hydraulic system filters should be checked, cleaned, and/or replaced as necessary, at the specified intervals required in the Lubrication Chart in Section 1. Always examine filters for evidence of metal particles.
3. Cloudy oils indicate a high moisture content which permits organic growth, resulting in oxidation or corrosion. If this condition occurs, the system must be drained, flushed, and refilled with clean oil.
4. It is not advisable to mix oils of different brands or types, as they may not contain the same required additives or be of comparable viscosities. Good grade mineral oils, with viscosities suited to the ambient temperatures in which the machine is operating, are recommended for use.

NOTE: *Metal particles may appear in the oil or filters of new machines due to the wear-in of meshing components.*

Hydraulic Oil

1. Refer to Section 1 for recommended viscosity ranges.
2. JLG recommends Mobilfluid 424 hydraulic oil, which has an SAE viscosity of 10W-30 and a viscosity index of 152.

Changing Hydraulic Oil

1. Use of any of the recommended hydraulic oils eliminates the need for changing the oil on a regular basis. If it is necessary to change the oil, use only those oils meeting or exceeding the specifications appearing in this manual. If unable to obtain the same type of oil supplied with the machine, consult local supplier for assistance in selecting the proper equivalent. Avoid mixing petroleum and synthetic base oils. JLG Industries recommends changing the hydraulic oil every 2 years.
2. Use every precaution to keep the hydraulic oil clean. If the oil must be poured from the original container into another, be sure to clean all possible contaminants from the service container.
3. While the unit is shut down, a good preventive maintenance measure is to make a thorough inspection of all hydraulic components, lines, fittings, etc., as well as a functional check of each system, before placing the machine back in service.

Lubrication Specifications

Specified lubricants, as recommended by the component manufacturers, are always the best choice, however, multi-purpose greases usually have the qualities which meet a variety of single purpose grease requirements. Should any question arise regarding the use of greases in maintenance stock, consult a local supplier for evaluation. Refer to Section 1 of this Service Manual for an explanation of the lubricant key designations appearing in the Lubrication Chart.

SECTION 3. BASE COMPONENTS

3.1 BASE ASSEMBLY COMPONENTS

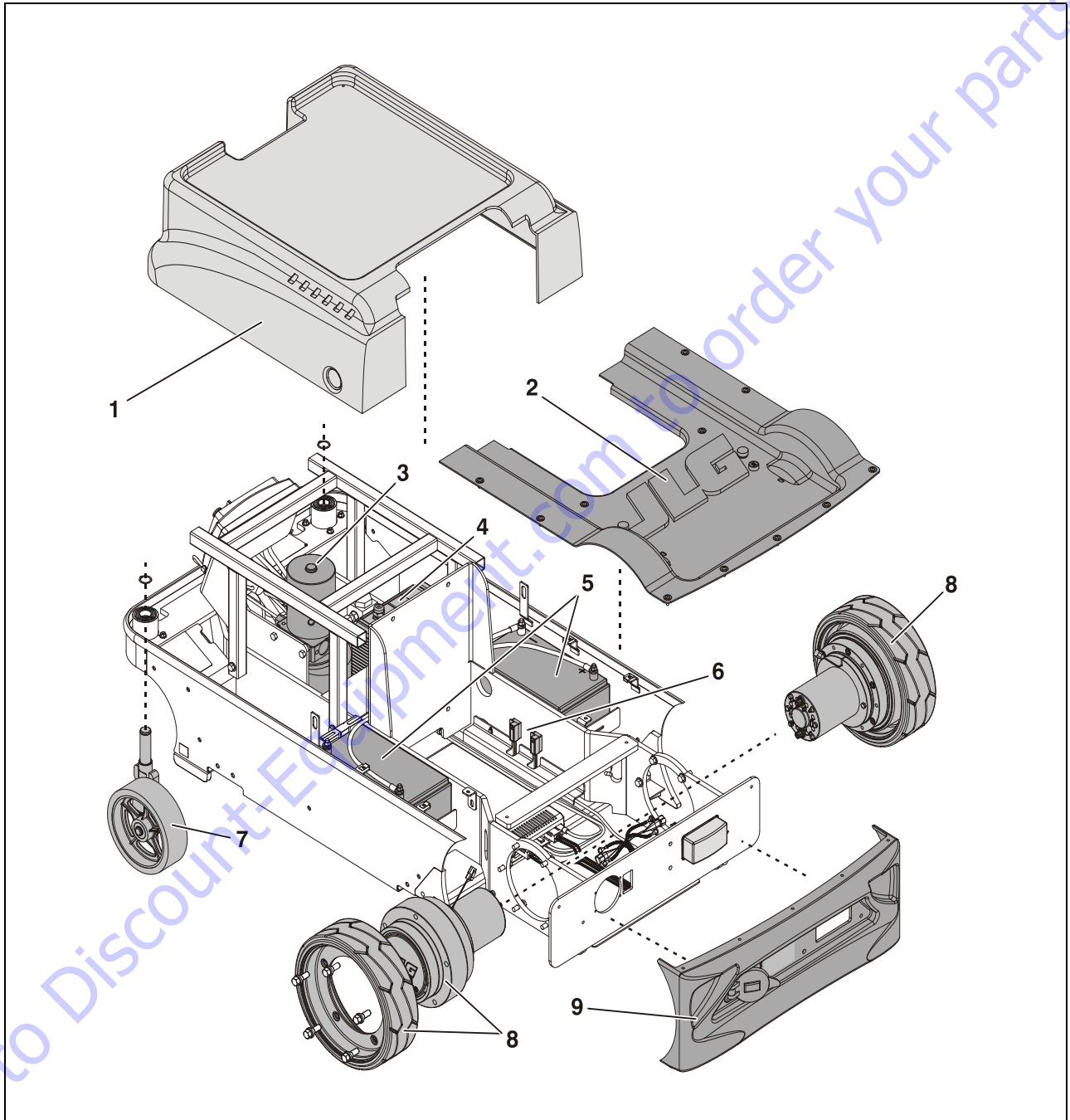

Figure 3-1. Base Components (Prior to SN 0130032507)

- | | | |
|-----------------------------------|--|------------------------------------|
| 1. Front Cover | 4. Battery Charger | 6. Limit Switches (Mast-Activated) |
| 2. Drive Motor Cover | 5. Batteries (2 - 12V; OR
4 - 6V, two on each side) | 7. Front Caster Wheels |
| 3. Hydraulic Pump Motor/Reservoir | | 8. Drive Motor Assemblies |
| | | 9. Rear Bumper Cover |

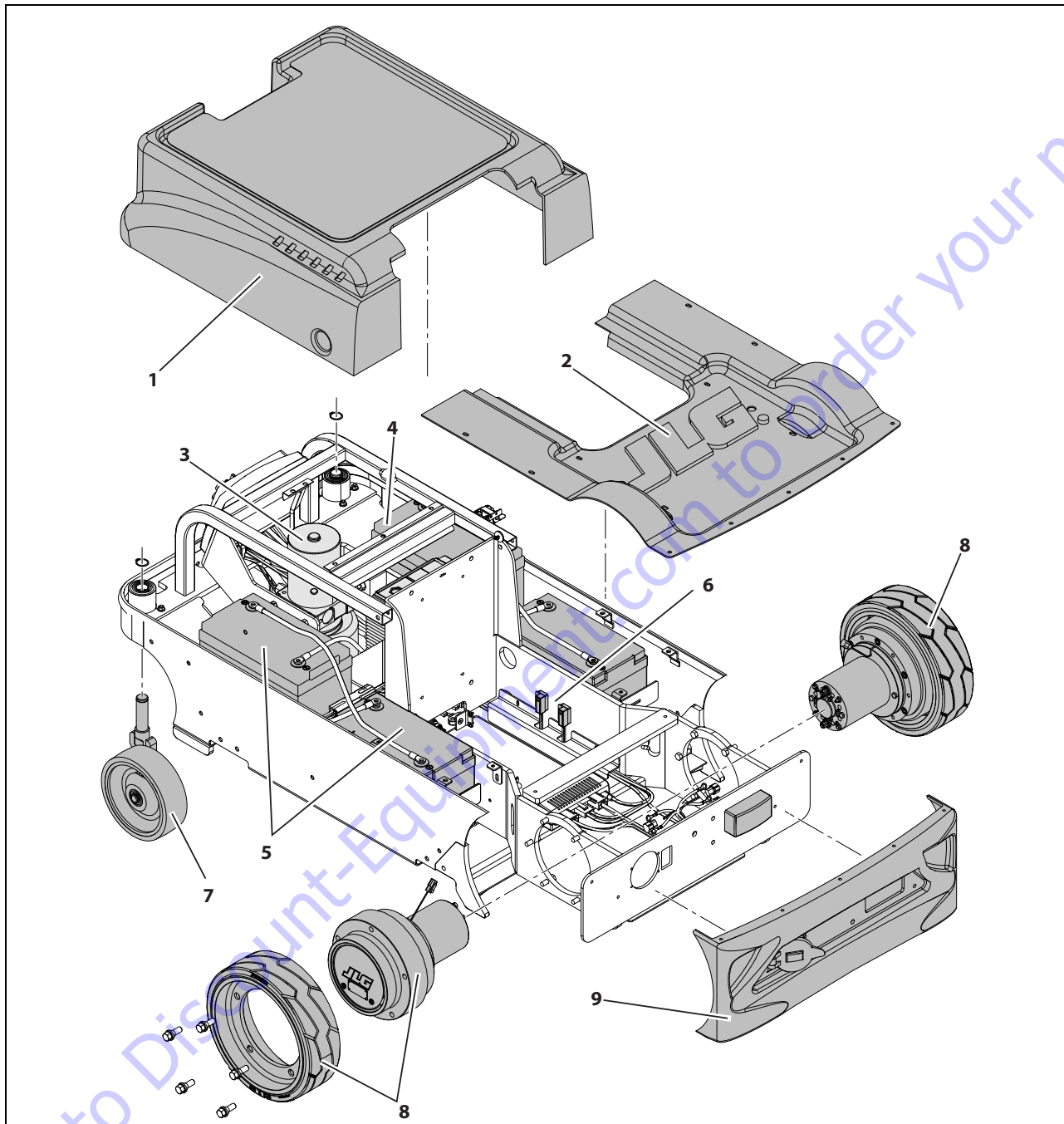
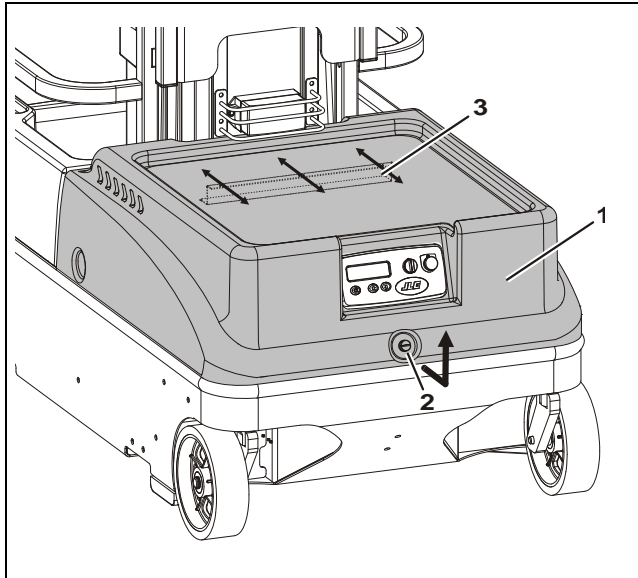

Figure 3-2. Base Components (SN 0130032507 to Present)

- | | | |
|-----------------------------------|---|---------------------------|
| 1. Front Cover | 4. Battery Charger | 7. Front Caster Wheels |
| 2. Drive Motor Cover | 5. Batteries (4 - 6V, two on each side) | 8. Drive Motor Assemblies |
| 3. Hydraulic Pump Motor/Reservoir | 6. Limit Switches (Mast-Activated) | 9. Rear Bumper Cover |

3.2 BASE FRAME COVERS

Hood (Carry Deck)



- 10. Hood (Carry Deck)
- 11. Attach Screw
- 12. Rear Hold-Down Bracket (located under hood; slides under hood support)

NOTE: The Carry Deck has a maximum capacity of 250 lb (115 kg).

1. Unscrew the attach screw to release hood from the frame mount under the cover.
2. Lift the hood slightly out of the frame gasket and slide deck forward till the rear hold-down bracket clears the support frame under the hood.
3. Lift to remove deck from machine.

Hood (Carry Deck) Frame

Prior to SN 0130032507:

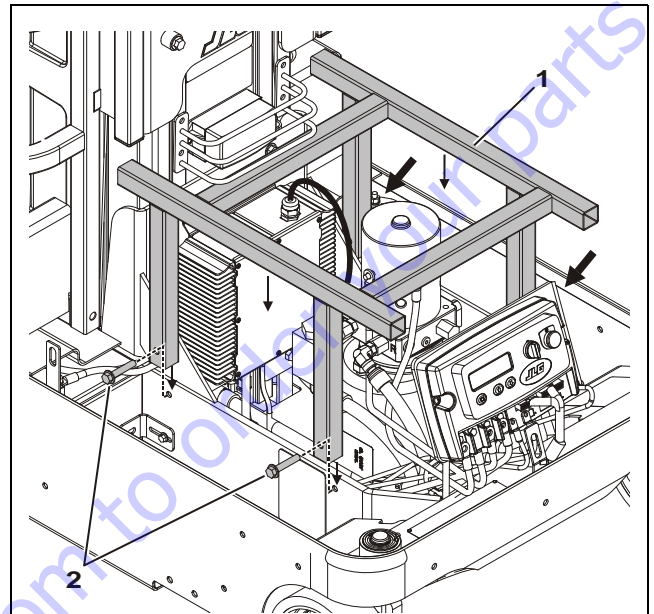

- 1. Carry Deck Support
- 2. Support Screws (4 places)
(Apply Loctite #242)

SN 0130032507 to Present:

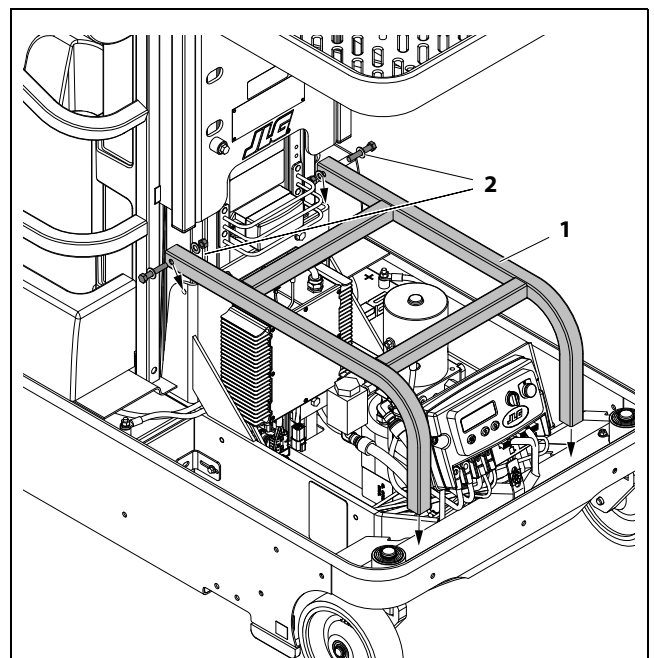

- 1. Carry Deck Support
- 2. Support Screws, Nuts, Washers

Drive Motor Cover

To gain access to the drive motor cover and screws, elevate the platform.

⚠ WARNING

NEVER WORK UNDER AN ELEVATED PLATFORM UNTIL THE PLATFORM HAS BEEN SAFELY RESTRAINED FROM ANY MOVEMENT BY BLOCKING OR OVER-HEAD SLING.

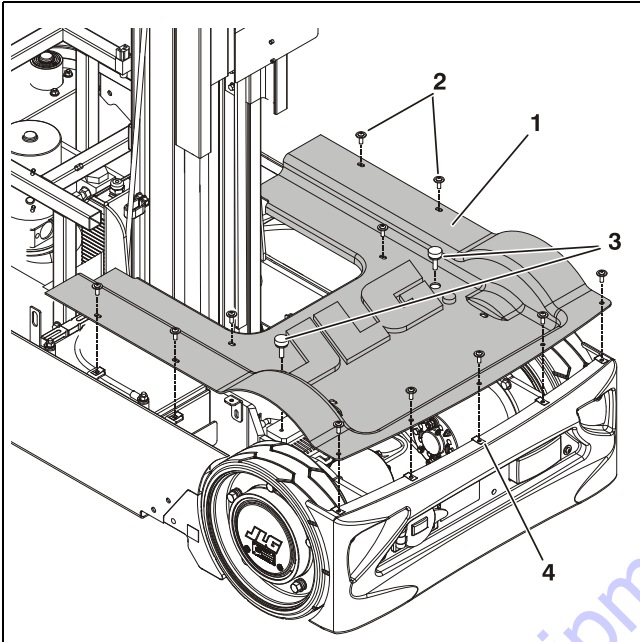

- 1. Cover
- 2. Screws/Washers (a)
- 3. Platform Stop (a) (b)
- 4. U-Style Tapped Nuts

NOTE: (a) Apply Loctite #242 to threads before tightening.
 (b) Height of the platform stops is set by installing two 5/16" dia. wide plain steel flatwashers under the head of each stop, tighten securely.

Rear Bumper Cover

The five screws that attach the drive motor cover to the rear bumper must be removed before the rear bumper cover can be removed.

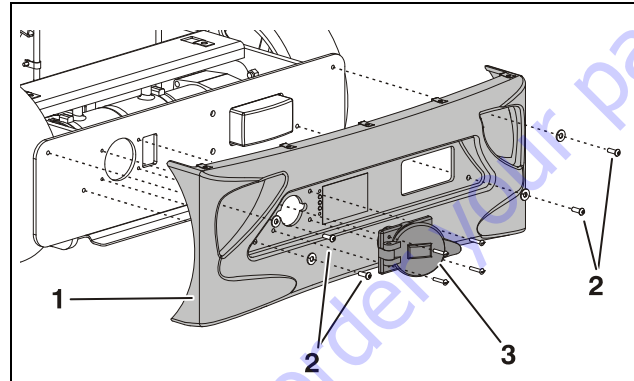

- 1. Bumper Cover
- 2. Screws/Washers
- 3. AC Input - Receptacle Assembly Cover

3.3 DRIVE AND CASTER WHEELS

Tire Wear and Damage

The tire and rim assemblies installed on machines have been approved by the tire manufacturer for applications in which those products are intended to be used. The tire and rims installed on each product model have been designed for stability requirements, which consist of track width, tire compound, and load capacity. Tire changes such as rim width, centerpiece location, larger or smaller diameter, tire compound, etc., without written manufacturers approval, could result in an unsafe condition regarding stability.

The tires and rims installed on machines are to be inspected daily as part of the daily walk-around inspection. JLG requires that the daily walk-around inspection be performed at each operator change during a shift and at each shift change.

Wheel and Tire Replacement

JLG recommends that any replacement tire be the same size and brand as originally installed on the machine or offered by JLG as an approved replacement. Please refer to the JLG Parts Manual for the part number of the approved tires for a particular machine model.

If any of the following is discovered during tire inspection, measures must be taken to remove the JLG product from service immediately. Arrangements must be made for replacement of the tire(s) or tire assembly(s). Both tires/wheels on the same axle must be replaced:

- If the overall diameter of the tire is less than one of the following:
100 x 323 Tire – 12.25 in. (311mm) minimum
- If any uneven wear is discovered.

A tire with significant damage in the tread area or sidewall requires immediate evaluation before placing the machine into service. If a cut, tear, chunk, or other discrepancy exceeds any one or more of the following dimensions, the tire must be replaced:

3.0 in. (76 mm) long
0.75 in. (19 mm) wide
0.75 in. (19 mm) deep

- If the metal wheel is visible at any point through the tread area of the tire.

If more than one discrepancy exists in any quadrant of the wheel (within 90 degrees of one another).

Wheel Installation

It is extremely important to apply and maintain proper wheel mounting torque.

⚠ WARNING

WHEEL BOLTS MUST BE INSTALLED AND MAINTAINED AT THE PROPER TORQUE TO PREVENT LOOSE WHEELS, BROKEN WHEEL BOLTS, AND POSSIBLE SEPARATION OF WHEEL FROM THE HUB. BE SURE TO USE ONLY THE WHEEL BOLTS MATCHED TO THE CONE ANGLE OF THE WHEEL.

Tighten the wheel bolts to the proper torque (see Table 3-1) to prevent wheels from coming loose. Use a torque wrench to tighten the fasteners. If a torque wrench is unavailable, tighten the fasteners with a lug wrench, then immediately have a service garage or dealer tighten the wheel bolts to the proper torque. Over-tightening will result in breaking the wheel bolts or permanently deforming the mounting holes in the wheels. The proper procedure for attaching wheels is as follows:

1. Start all wheel bolts by hand to prevent cross threading. DO NOT use a lubricant on threads or nuts.
2. Tighten wheel bolts in the following sequence.

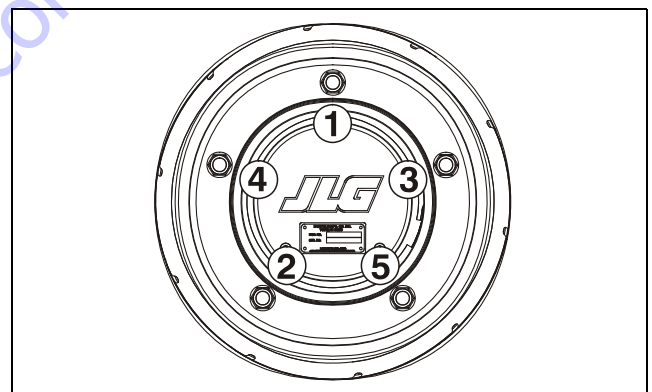

Figure 3-3. Wheel Bolts Tightening Sequence

3. The tightening of the wheel bolts should be done in stages. Following the recommended sequence, tighten wheel bolts per wheel torque.

Table 3-1. Wheel Torque Chart

TORQUE SEQUENCE		
1st Stage	2nd Stage	3rd Stage
20-30 ft.lbs. (28 - 42 Nm)	65-80 ft.lbs. (91 - 112 Nm)	105 - 120 ft.lbs. (142 - 163 Nm)

4. Wheel bolts should be torqued after the first 50 hours of operation and after each wheel removal. Check torque every 3 months or 150 hours of operation.

(Front) Caster Wheel Installation

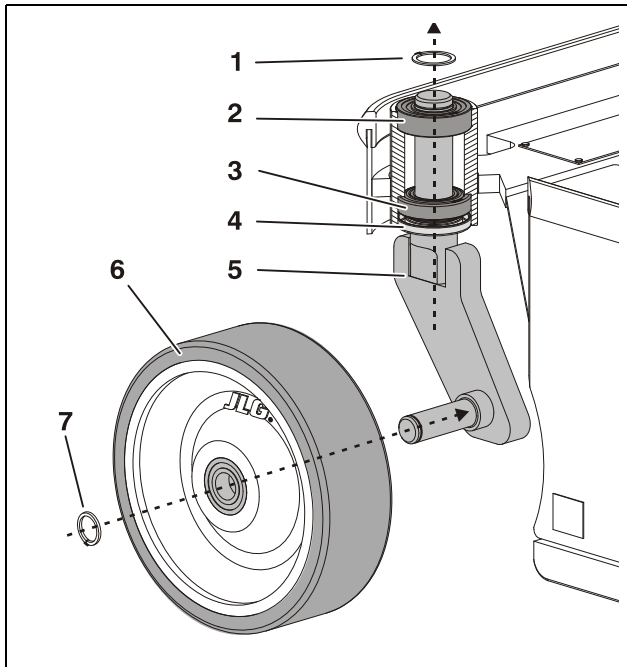

- 5. Snap Ring
- 6. Upper Bearing (a)
- 7. Lower Bearing (a)
- 8. Spindle Shaft Seal
- 9. Spindle/Axle Assy.
- 10. Caster Wheel (b)
- 11. Snap Ring (c)

NOTE: Base is shown cutaway for illustrative purposes only.

(a) If replacing bearing, pack bearing completely full of grease before assembling, use (JLG P/N-3020029 - Mobil SHC 460 Synthetic or equivalent). Tap in evenly until seated.

(b) Coat axle shaft with Loctite Moly Paste lubricant before assembling wheel. Wheel axle bearings are maintenance-free (original spoke wheel mounts same).

(c) After installing the wheel and just before installing the Snap Ring, wipe the end of the axle clean and coat the end of the axle with clear varnish.

3.4 DRIVE/ELEVATION CUT-OUT SWITCH INSTALLATION

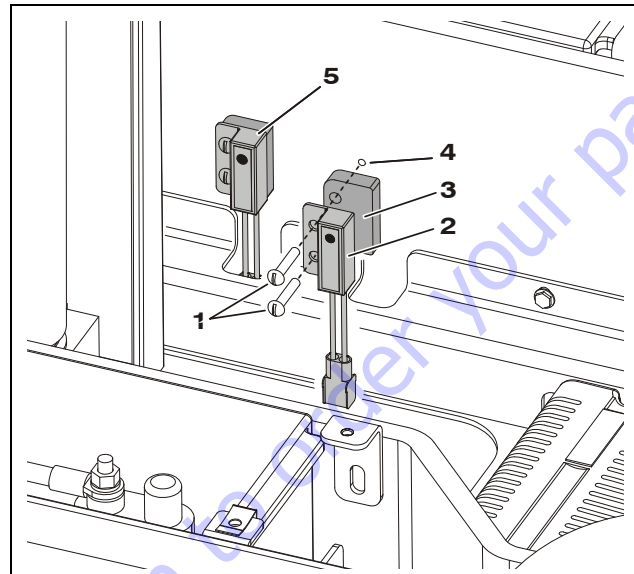

- 12. Mounting Screws (a)
- 13. Proximity Switch (b)
- 14. Switch Mounting Block
- 15. Mounting Holes
- 16. Proximity Switch (b)

NOTE: **(a)** Apply Loctite #242 to mounting screw threads on final assembly.

(b) This machine has two drive/elevation cut-out proximity switches. If one fails the other will continue to operate. Both are plugged into the wiring harness to the P2 connector on the Ground Control Station. If either switch fails, the Ground Control Module will signal a fault condition.

3.5 WHEEL DRIVE ASSEMBLY SERVICING

The component parts of the left and right drive motor assemblies are identical. The left drive motor is run in the reverse direction of the right motor.

Roll and Leak Testing

Torque hub units should always be roll and leak tested before disassembly and after assembly to make sure that the unit's gears, bearings and seals are working properly. The following information briefly outlines what to look for when performing these tests.

NOTE: *The brake must be released before performing the roll test. This can be accomplished by supplying 24 V DC to the gray 2-pin brake connector.*

The Roll Test

The purpose of the roll test is to determine if the unit's gears are rotating freely and properly. The wheel or hub of the torque hub should rotate by hand. If more drag is felt in the gears only at certain points, then the gears are not rolling freely and should be examined for improper installation or defects. Some gear packages roll with more difficulty than others. Do not be concerned if the gears in the unit seem to roll hard as long as they roll with consistency.

The Leak Test

The purpose of a leak test is to make sure the unit is air tight. If the unit has a leak, the pressure gauge on the leak checking fitting will start to fall after the unit has been pressurized and allowed to equalize. Leaks will most likely occur at the pipe plugs, the main seal or wherever o-rings are located. The exact location of a leak can usually be detected by brushing a soap and water solution around the main seal and where the o-rings or gaskets meet on the exterior of the unit, then checking for air bubbles. If a leak is detected in a seal, o-ring or gasket, the part must be replaced and the unit rechecked. Leak test at 10 PSI for 20 minutes.

NOTE: *Due the small air volume inside this torque hub, it will pressurize to 10 PSI very quickly. If the pressure becomes excessive in the unit, the seals will be destroyed.*

Oil Type and Capacity

This torque hub unit is shipped with ISO 68 viscosity oil (hydraulic fluid). It is designed to utilize the same oil throughout its service life. However, should it need to be serviced the oil will need to be drained and replaced.

In the event of servicing, fill the unit with 10 oz of ISO grade 68 oil or oil of a similar viscosity (80W gear oil or 20W engine oil).

Oil Filling Instructions

Ten oz of oil will fill the cavity approximately half-full.

1. To check the oil level, rotate the wheel so that the cover plugs are at 12 o'clock and 3 o'clock.
2. Allow the oil to settle. Slowly loosen the 3 o'clock plug. If oil begins to come out then the oil level is sufficient. If no oil is noticed at the 3 o'clock plug location, then remove both plugs.
3. Slowly add oil at the 12 o'clock plug location until oil begins to seep out of the 3 o'clock plug location. Reinstall and tighten plugs to 6-8 ft.lbs.

Drive Motor Brush Wear - Warning Indication

The machine's drive motors include brush wear sensors that activate a warning indicating the drive motor brushes will require replacement soon. This warning protects the drive motors from damage due to extreme brush wear.

When the brush wear warning is activated the Ground Control Station LCD screen will indicate a fault code of 6, also the hour-meter is set to countdown 25 hours of (DRIVE) operation remaining.

The Platform Control LEDs will indicate this warning with 8 flashing LEDs and an intermittent beep.

NOTE: *Only the drive function when used will affect the hour meter count down once the warning has been activated. The machine will operate normally until the last 10 seconds of the 25 hour countdown.*

During the last 10 seconds of the 25 hour (DRIVE) countdown the machine will only drive in creep/turtle drive mode and platform lift up will be disabled. At this point cycling power on/off will only repeat the final 10 second mode cycle.

The machine will not operate normally until the drive motor brushes are replaced (repositioning the brush warning sensors), and the Ground Control Station is programmed to reset the Brush Wear - Warning Timer. Refer to Ground Control Module Programming in Section 4 of this manual.

Wheel Drive Assembly Removal

The electric wheel drive assemblies are mounted independent of each other in the base frame at the rear of the machine.

The wheel drive assembly consists of a 24 V DC electric motor driving a 30.68:1 ratio torque hub. The assembly also includes a friction disk parking brake assembly. This brake assembly is mounted internally on the drive assembly between the drive motor and the torque hub assembly.

1. Elevate the platform to gain access to the drive motor cover and screws.
2. Remove cover and screws. (Refer to Section 3.2.)
3. Disconnect the positive battery terminals from the left side battery.
4. Raise the rear drive wheels of the machine off the ground using a fork truck or floor jack. Place a block or safety stand under machine.
5. Remove the drive wheel mounting bolts and remove the wheel(s).
6. Disconnect the power harness terminals and brake harness connector(s) from the drive motor.
7. Remove the six hex head cap screws and washers attaching the drive assembly to the frame.
8. Carefully slide the drive motor assembly out of the base frame assembly for disassembly.

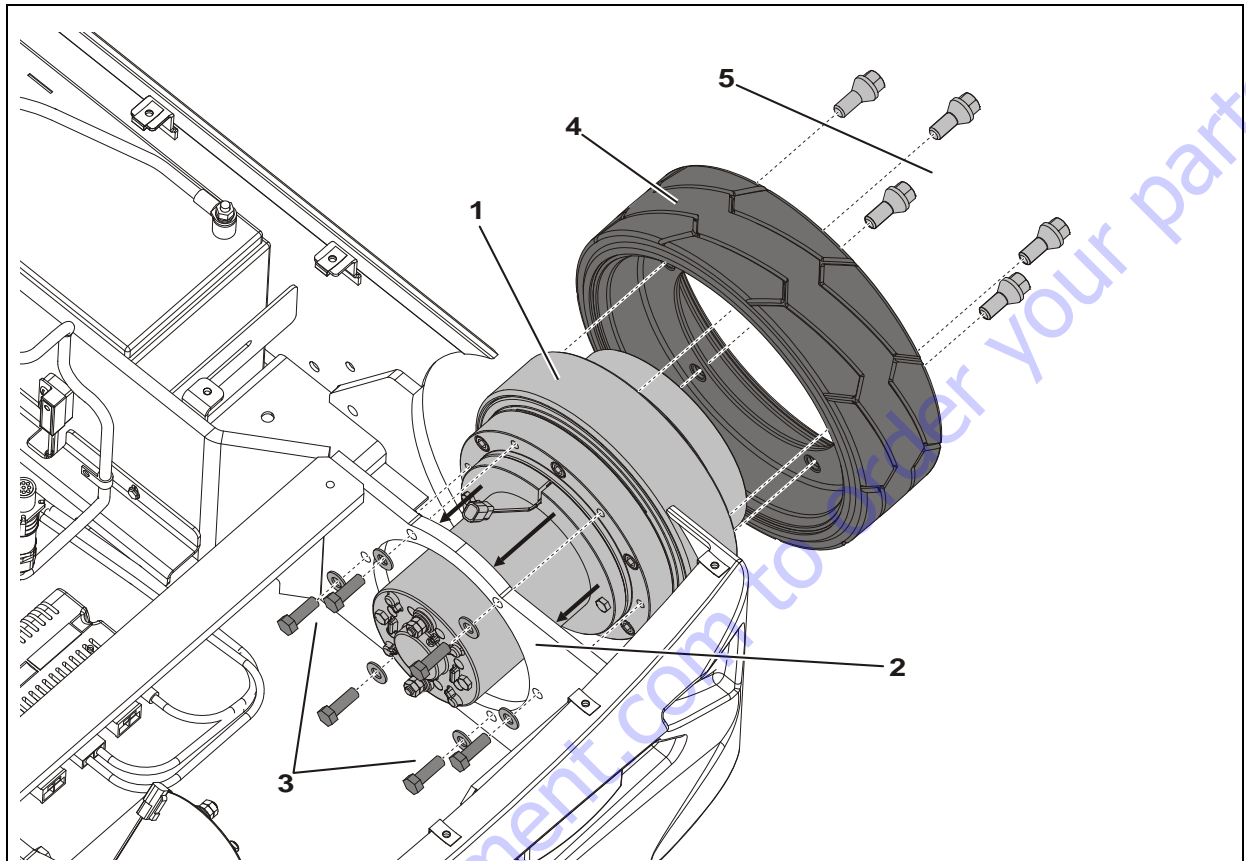

Figure 3-4. Wheel Drive Assembly Installation (Right Side Shown)

- | | |
|---|---|
| <ul style="list-style-type: none"> 1. Wheel Drive Assembly 2. Frame Mounting Surface 3. Mounting Bolts/Washers (a) | <ul style="list-style-type: none"> 4. Drive Wheel 5. Wheel Mounting Bolts (b) |
|---|---|

NOTE: Installation same for left and right drive motor:
(a) Apply Loctite #242 to threads before tightening.
(b) Tighten to 120 ft.lbs. (534 Nm).

Wheel Drive Main Components Disassembly

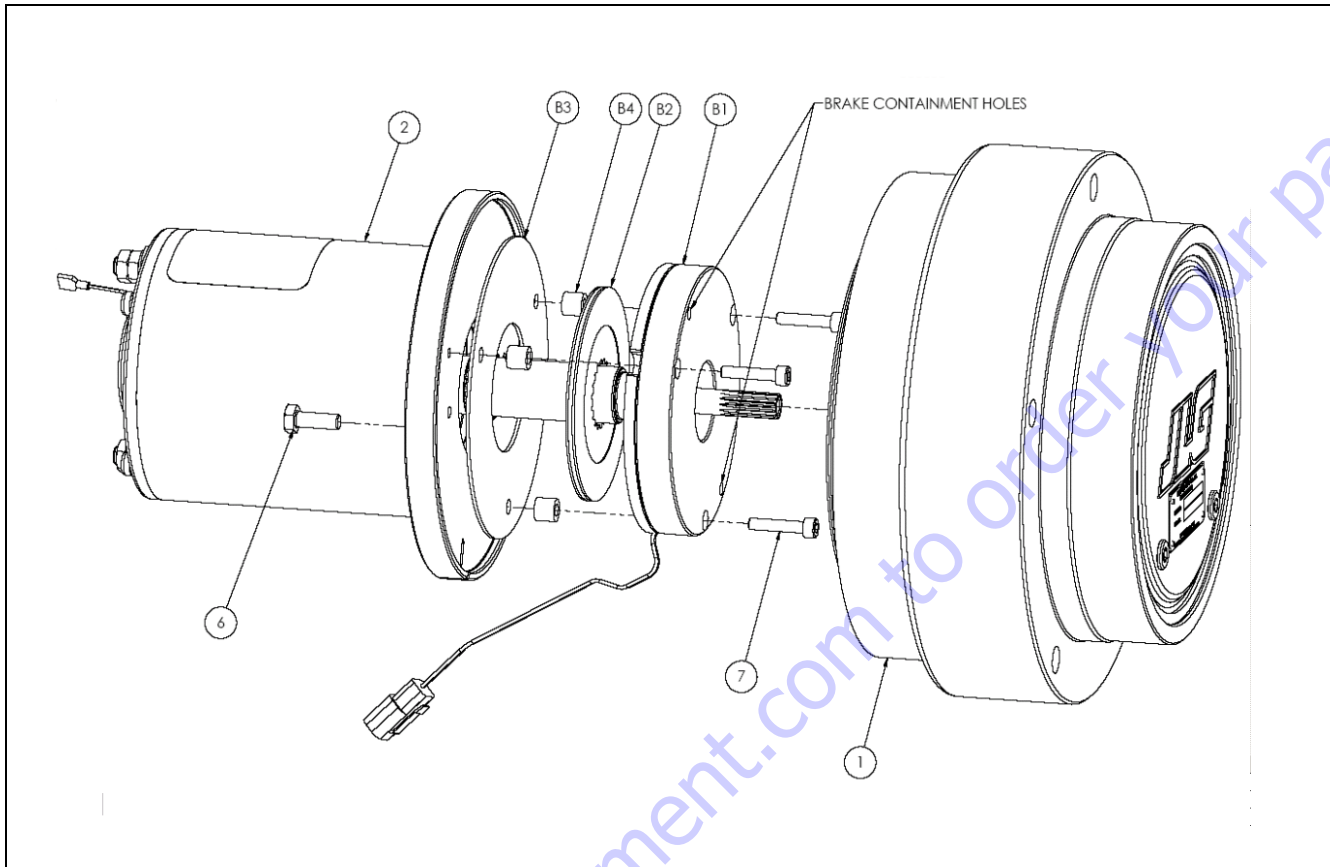

Figure 3-5. Drive Motor Disassembly

NOTE: If possible, remove the wheel drive assembly from the machine frame.

1. Drain the oil from the **Torque Hub (1)** by removing the cover plugs in the cover.
2. Remove the 2 **Drive Motor Bolts (6)** and slowly pull the **Motor (2)** out of the torque hub.
3. Obtain and install 2 bolts (M5 x 0.8 - 20mm long) into the brake containment holes. This will keep the brake housing in one piece.
4. Cut the black wire tie (not shown) from the frame of the motor.

5. Remove the 3 **Brake Bolts (7)**.
6. Remove the **Brake Housing (B1)** and the **Spacers (B4)**.

NOTE: The brake wires will have some silicone sealant at the slot through the motor flange. It is okay to pull the wire out of the motor flange slot. The slot will have to be re-sealed during reassembly.

7. Remove the **Brake Disc (B2)** from the splined motor shaft.
8. Remove the **Brake Friction Plate (B3)** from the motor flange.

Replacing Drive Motor Brushes

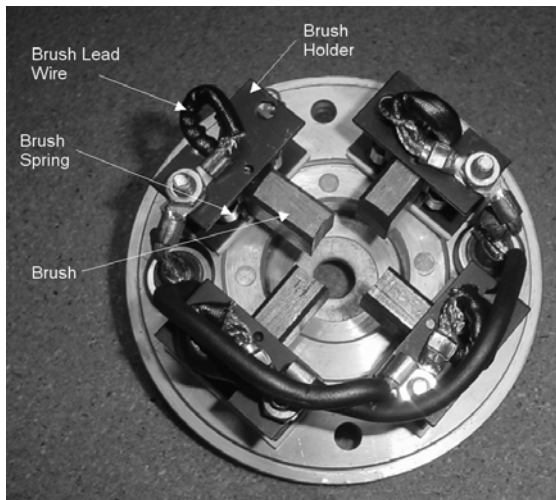

Figure 3-6. Drive Motor Brush Holder Components

NOTICE

THE MOTOR MUST BE DISASSEMBLED FROM TORQUE HUB AND DISCONNECTED FROM MACHINE CONTROLLER BEFORE BEGINNING THIS PROCEDURE.

1. Wrap tape around end of the motor shaft that interfaces with the torque hub to avoid damage to this area.
2. Remove the motor thru bolts.
3. Remove motor flange/brake mount from motor frame.
4. Remove brush housing from motor frame and armature by tapping the edge of brush housing with a soft-tipped mallet. The brushes will spring towards the center of the brush housing once it has separated from armature.
5. Remove the wave spring washer from the bearing bore of the brush housing and set aside.
6. Pick a brush and remove the screw that fastens its lead to the brush holder.

NOTE: *If this is a wear indicator brush, then there will be a second lead that will need to be removed from a spade terminal in the brush housing.*

7. Remove the brush and brush spring. Inspect for corrosion and clean away any that is found.
8. Install a new brush spring into the brush holder. Make sure that it is oriented in its correct recoil direction.

NOTE: *The spring contains a flat area with a coil at each end. The spring should be oriented such that the bend from the flat area to the coil is towards the brush.*

9. Install a new brush into brush holder; ensure orientation of lead wire is the same as the other brushes.
10. Push new brush up into brush holder. Insert a pin (or a straightened paper clip) into small hole in the brush housing to keep brush held up in brush holder.

11. Connect brush lead wire to brush holder; tighten to 30 in-lbs. If this is a wear indicator brush, connect brush wear indicator lead to spade terminal in brush housing.
12. Repeat steps 6-9 for the other 3 brushes.
13. Remove armature from motor frame by grabbing the commutator and quickly pulling it from motor frame.

NOTICE

THE PERMANENT MAGNETS IN THE MOTOR FRAME ARE STRONG AND WILL TRY TO KEEP THE ARMATURE IN THE MOTOR FRAME. SECURE A FIRM GRIP ON BOTH THE ARMATURE AND THE MOTOR FRAME DURING THIS STEP.

14. Using compressed air, clean brush dust from armature, motor frame, adapter plate, and brush holder assembly.
15. Carefully reinstall the armature back into the motor frame so the commutator end of the armature is at the end of the frame with the timing marks.

NOTICE

THE PERMANENT MAGNETS IN MOTOR FRAME ARE STRONG AND WILL TRY TO PULL ARMATURE IN THE MOTOR FRAME. SECURE A FIRM GRIP ON BOTH ARMATURE AND MOTOR FRAME IN ORDER TO CONTROL SPEED OF THIS INSTALLATION. ENSURE FINGERS REMAIN CLEAR OF ARMATURE AND FRAME.

16. Install wave spring washer back into bearing bore of brush holder assembly. Ensure it is oriented so the spring touches outer raceway of armature bearing.
17. Install brush housing onto end of motor frame and armature; use a soft-tipped mallet if necessary. Once brush housing is partially on armature, brush retaining pins must be removed.

NOTE: *Do not pinch any wires between frame and brush housing.*

18. Line up timing marks between brush housing and motor frame.
19. Install the motor bolts.
20. Install motor flange so tapped holes line up with motor bolts.

NOTICE

WHEN TIGHTENING MOTOR HOUSING TO MOUNTING FLANGE, ENSURE MOUNTING BOLTS ARE NOT PROTRUDING TOO FAR THROUGH MOTOR MOUNTING FLANGE AND CONTACT BRAKE FRICTION PLATE ON OTHER SIDE OF FLANGE. THIS COULD WARP BRAKE FRICTION PLATE AND THE BRAKE WILL NOT WORK PROPERLY. IF NECESSARY, ADD ANOTHER WASHER UNDER HEAD OF MOTOR HOUSING MOUNTING BOLTS.

21. Tighten the motor bolts to 65 in-lbs.
22. Ensure timing marks are still aligned. If not, loosen bolts, line up the marks, and then retighten bolts.
23. Remove the protective tape from the motor shaft.

NOTICE

BEFORE MOUNTING DRIVE MOTOR/BRAKE ASSEMBLY TO TORQUE HUB SPINDLE, ENSURE BRAKE CAVITY IS CLEAN, DRY, AND FREE OF OIL RESIDUE.

Torque Hub Main Disassembly

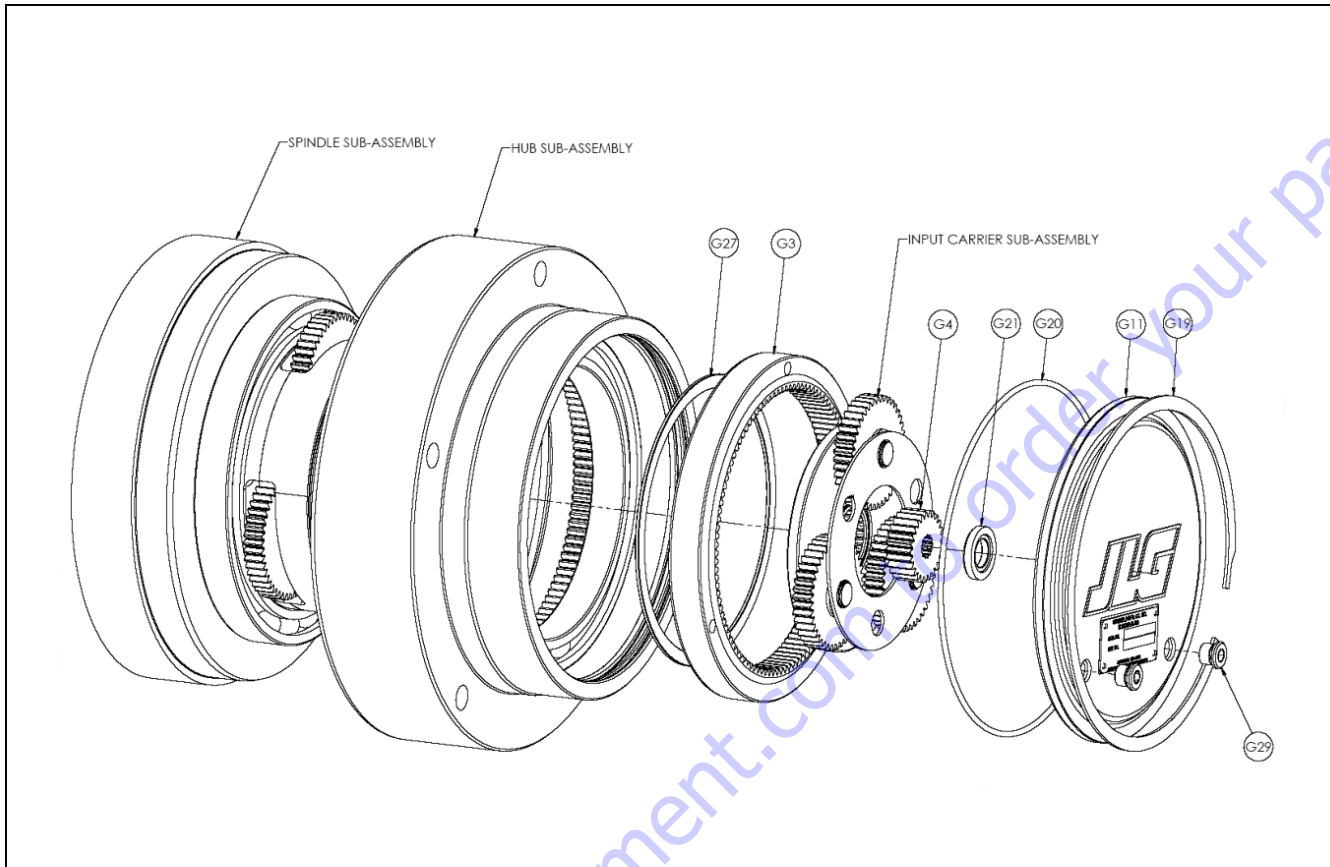

1. Using a screwdriver, pry the end of the **Retaining Ring (G19)** out of the groove in the **Hub Subassembly**. Grasp the loose end of the Retaining Ring and pull the rest of the way out.
2. Remove **Cover (G11)**. **Thrust Washer (G21)** should remain in the inner counterbore of the Cover when removed.

NOTE: To remove the cover the motor must be removed. Slide a rod through the motor shaft hole and gently tap with a rubber hammer to force the cover out.

3. Remove Input **Sun Gear (G4)**.
4. Remove Input **Carrier Sub-assembly**.
5. Remove **Cover (11)** and **O-ring (G20)**.

6. Remove Input **Ring Gear (G3)**.

NOTE: The Input Ring Gear (G3) is held in with a press fit on its outside diameter. Insert jacking screws (1/4-20UNC, grade 8) with at least 1.5 inches of thread length into each of the three tapped holes to force the ring gear out. Be sure to alternate between the jacking screws to keep the ring gear from becoming misaligned in the bore. The screws will push against the outer race of the main bearing. This bearing will have to be replaced afterwards.

7. Using a screwdriver, remove **Spiral Retaining Ring (G27)**.
8. Pull **Hub Sub-assembly** off of the **Spindle Sub-assembly**.

Input Carrier Disassembly

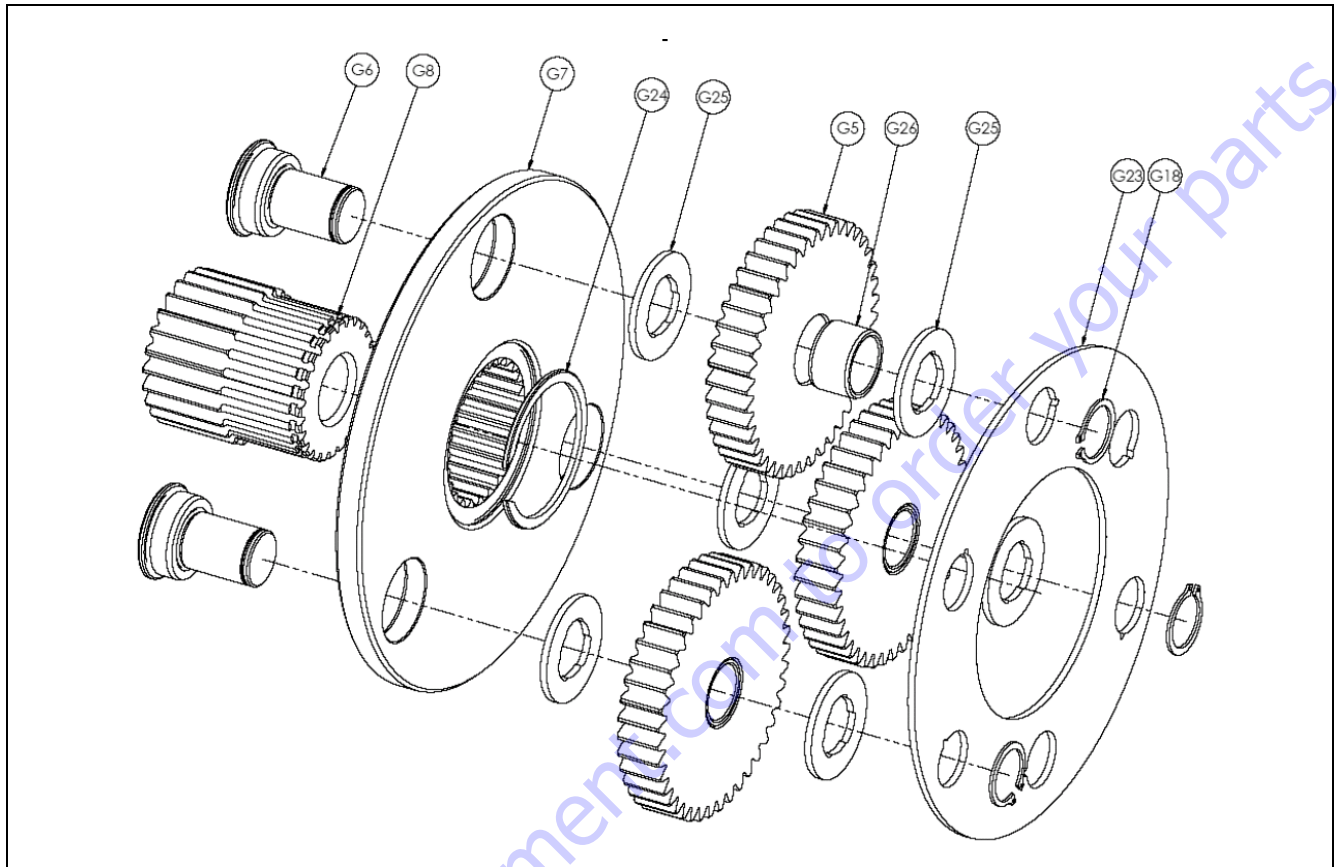

1. Remove **Retaining Rings (G18)** from each of the three **Planet Shafts (G6)**.
 2. Remove **Thrust Plate (G23)**.
 3. Remove **Thrust Washer (G25)** from each **Planet Shaft (G6)**.
 4. Slide each **Input Planet Gear (G5)** off the **Planet Shaft (G6)**.
 5. Press out **Bushing (G26)** from the bore of each **Planet Gear (G5)**. Bushings cannot be reused when removed.
 6. Remove the other **Thrust Washer (G25)** from each **Planet Shaft (G6)**.
 7. Remove **Retaining Ring (G24)** from **Output Sun Gear (G8)**.
 8. Slide **Output Sun Gear (G8)** out from the center of the **Input Carrier (G7)**.
 9. Remove the three **Planet Shafts (G6)** from the Input Carrier.
- NOTE:** The Planet Shafts (G6) are held in with a press fit. To avoid damage to the parts, use an arbor or hydraulic press to remove the Planet Shafts (G6).
- NOTE:** Do not overstress these Retaining Rings when removing them.

Hub Disassembly

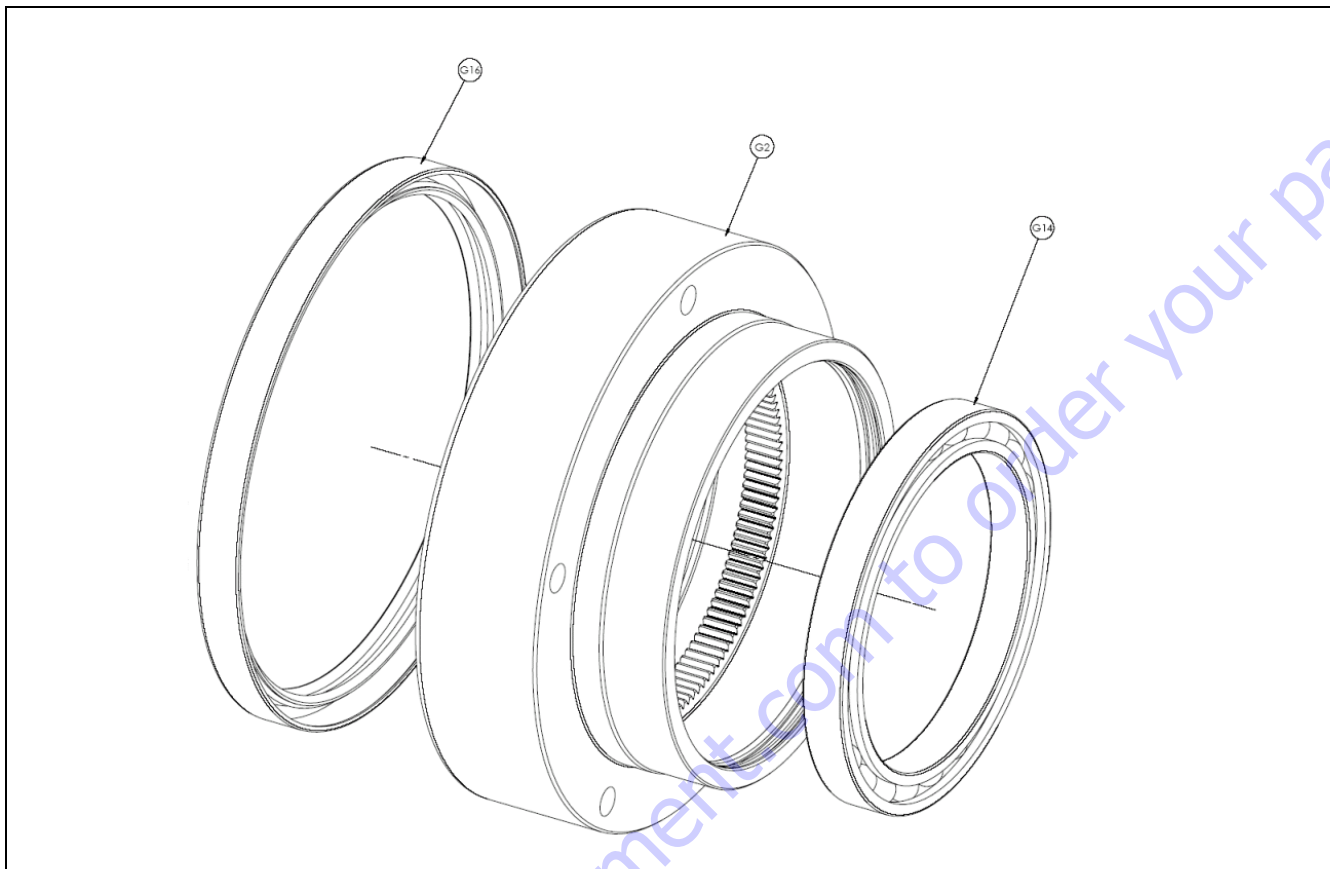

1. Remove **Main Wheel Bearing (G14)**.

NOTE: This part is held in the hub with a press fit. To remove have the hub setting seal side up. Use a plate or rod with a large enough diameter push in the inner race of the bearing. Apply force to the push the bearing out. This bearing will need to be replaced upon reassembly.

2. Remove main **Lip Seal (G16)**.

NOTE: This Lip Seal (G16) is also held in with a press fit. Remove the Lip Seal only if the hub or seal needs to be replaced. The Lip Seal will most likely become damaged during removal. Try not to damage the hub bore.

Spindle Disassembly

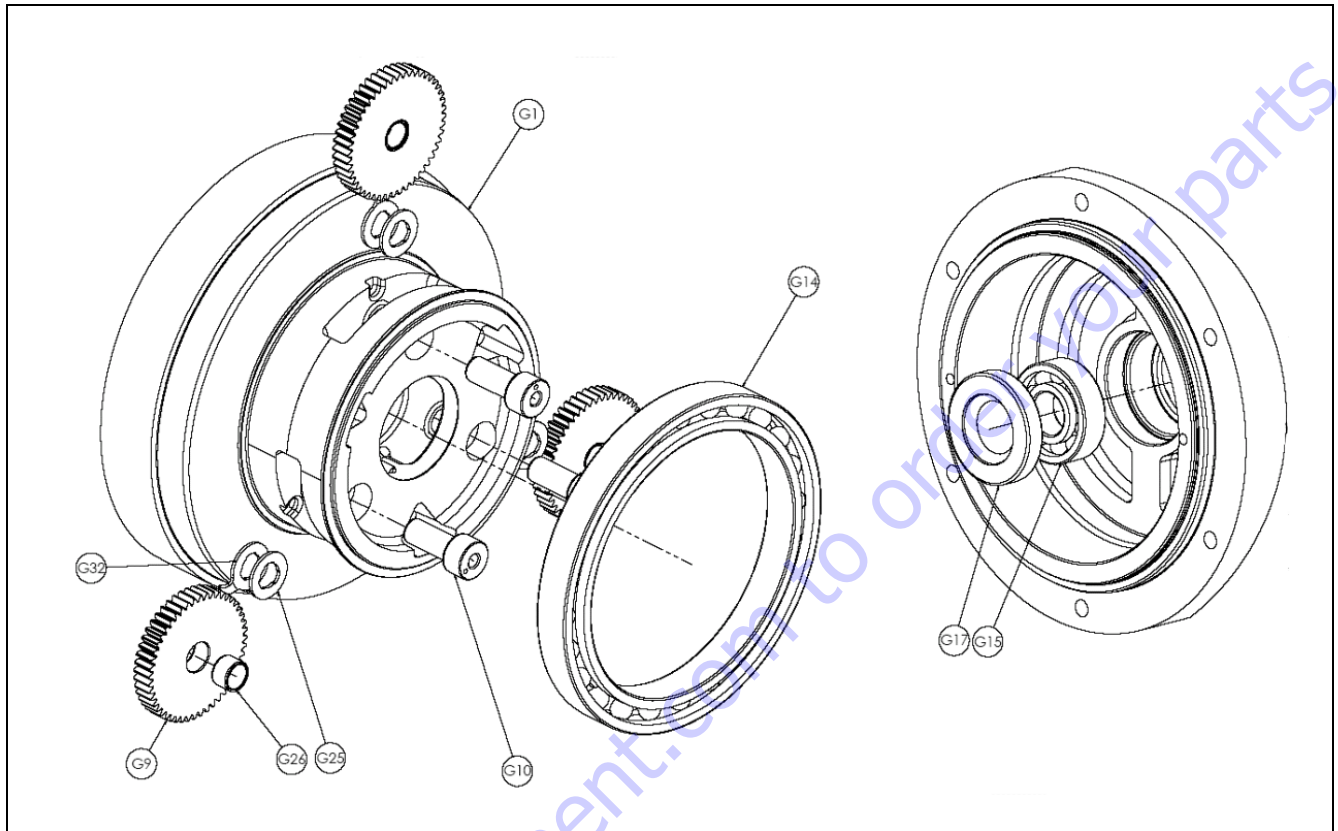

1. Place Spindle Sub-Assembly on bench with **Planet Gears (G9)** facing up.
- NOTE:** Do not damage or scratch the seal surface of the **Spindle (G1)** during disassembly.
2. Remove three **Output Planet Shafts (G10)**.
- NOTE:** These Planet Shafts are held in with a press fit. Use the tapped hole in the end of the pin in conjunction with a slide hammer or similar tool to remove them.
3. Remove the **Output Planet Gear (G9)**, **Thrust Washer (G25)**, and **Tanged Washer (G32)** out each of gear "window" of the **Spindle (G1)**.
- NOTE:** The Output Planet Gears (G9) are very similar in size to the Input Planet Gears (5), tag or label the Planet Gears to avoid confusion.
4. Press out **Bushing (G26)** from the bore of each **Planet Gear (G9)**. Bushings cannot be reused when removed
 5. Remove the **Main Bearing (G14)** from the outside diameter of the **Spindle (G1)**.
- NOTE:** This bearing is held in with a press fit. You will need to pry against the Spindle (1) to remove it. A new bearing should be used when the unit is reassembled.
6. Flip over the **Spindle (G1)**.
 7. Press out the **Motor Shaft Seal (G17)** from the center bore. The seal cannot be reused when removed
 8. Remove the shaft **Ball Bearing (G15)** from the center bore.

Spindle Sub-Assembly

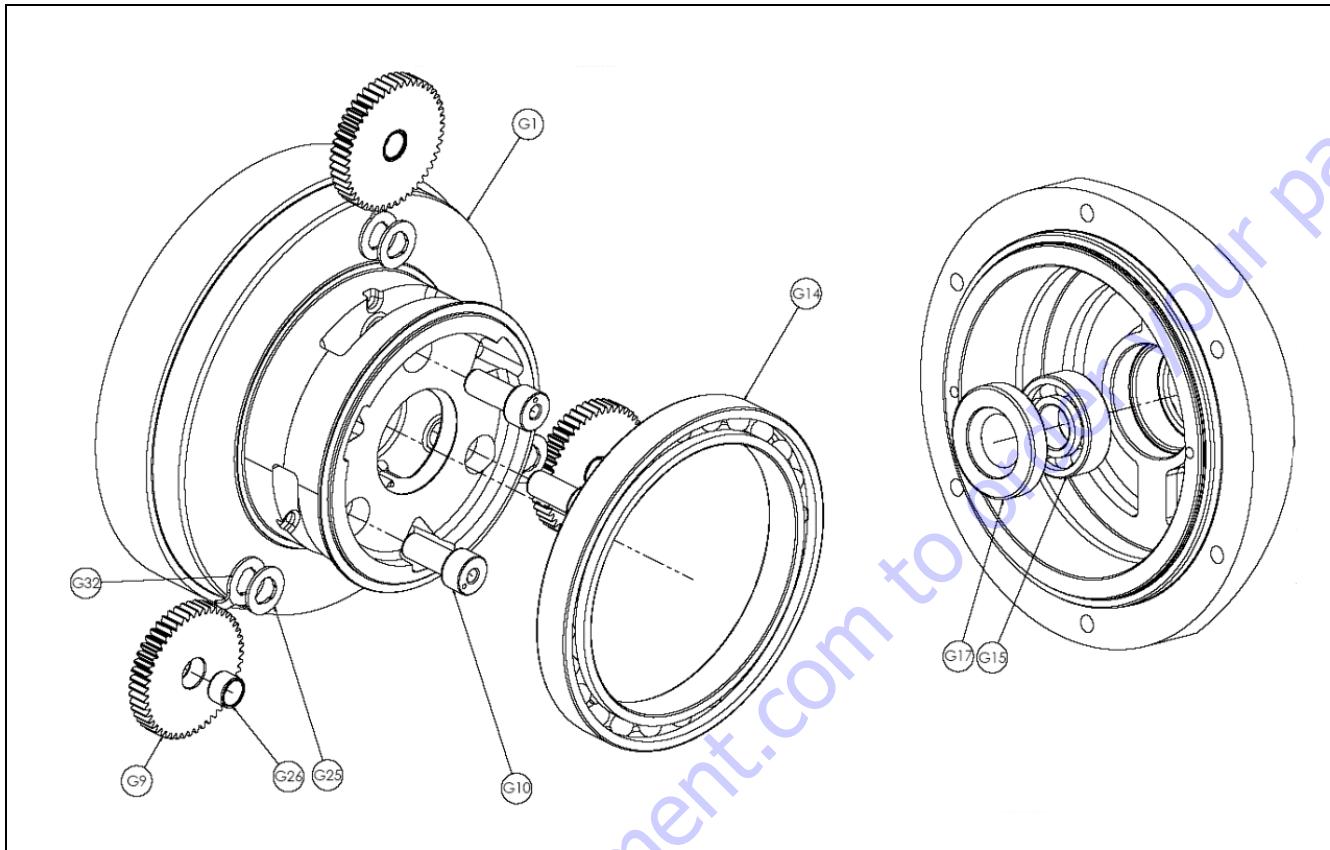

1. Place the **spindle (G1)** on the bench with the carrier portion facing up.

NOTE: Do not damage or scratch the seal surface of the spindle (G1) during assembly.

2. Using the appropriate pressing tool (T-182377), press on **Main Bearing (G14)** until it is fully seated.
3. Use the **Output Planet Pin (G10)** as a pressing tool to install the **Planet Bushing (G26)** into the bore of each **Planet Gear (G9)**. The shaft will help guide the bushing into the bore as well as prevent damage from the press.
4. Place **Tanged Thrust Washer (G32)** into each planet "window" of the **Spindle (G1)**. Make sure the tang sits in the cast groove on the inside of the window.
5. Place a **Thrust Washer (G25)** onto the **Output Planet Gear (G9)**. Line up the bores as best as you can. Use grease to hold the Thrust Washer in place.
6. Slide the **Output Planet Gear (G9)** into the window with the **Tanged Thrust Washer (G32)** until the bores line up.

7. Insert **Output Planet Shaft (G10)** into the Planet Shaft hole of the **Spindle (1)** and through the bores of the **Thrust Washers (G25) & (G32)** and the **Planet Gear (G9)**.
8. Before pressing the **Output Planet Shaft (G10)** into the **Spindle (G1)**, make sure the **Output Planet Gear (G9)** spins freely.
9. Press the **Output Planet Shaft (G10)** into the **Spindle (G1)** until it bottoms out. Make sure the **Output Planet Gear (G9)** spins freely after the Planet Shaft is pressed in.
10. Repeat Steps 5-11 for the other two **Output Planet Gears (G9)**.
11. Turn the **Spindle (G1)** over so that the carrier end is down.
12. Install **Input Ball Bearing (G15)** into the **Spindle (G1)** bore.
13. Using a flat plate or rod, press the **Motor Shaft Seal (G17)** into the center bore so that it is flush with the face of the **Spindle (G1)**.

Hub Sub-Assembly

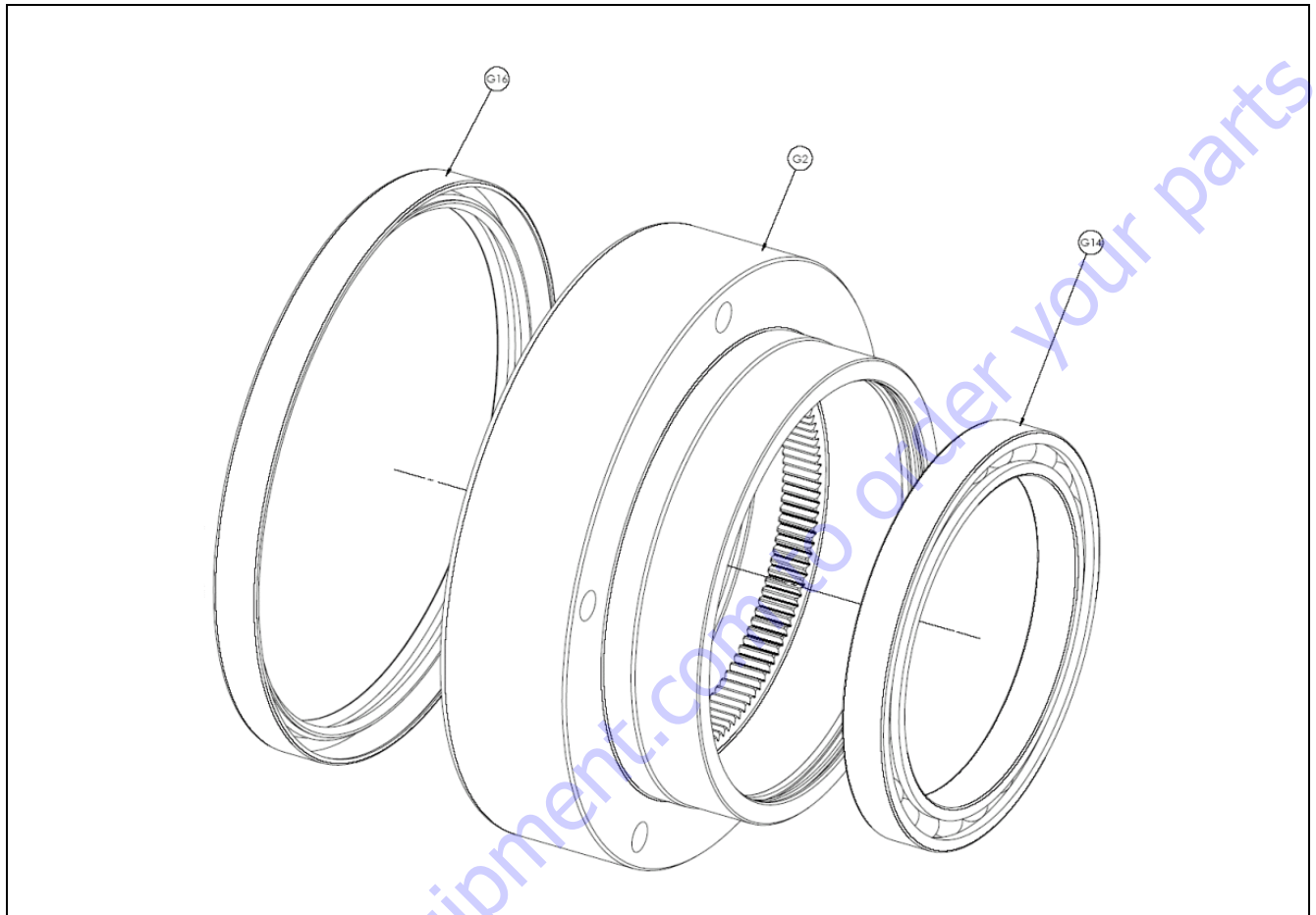

1. Put **Hub (G2)** on a table with the tapped holes facing down.
2. Using a flat plate in conjunction with a pressing tool, press in the **Seal (G16)** so it is flush with the edge of the hub.

NOTE: The seal has a thin outer shell that can be easily damaged if not installed with care. It is a good idea to start the Seal into the bore with a rubber mallet before pressing.

3. Flip the **Hub (G2)** over.
4. Using the appropriate pressing tool (T-174356), press the **Main Bearing (G14)** into the bore until it bottoms out.

Input Carrier Sub-Assembly

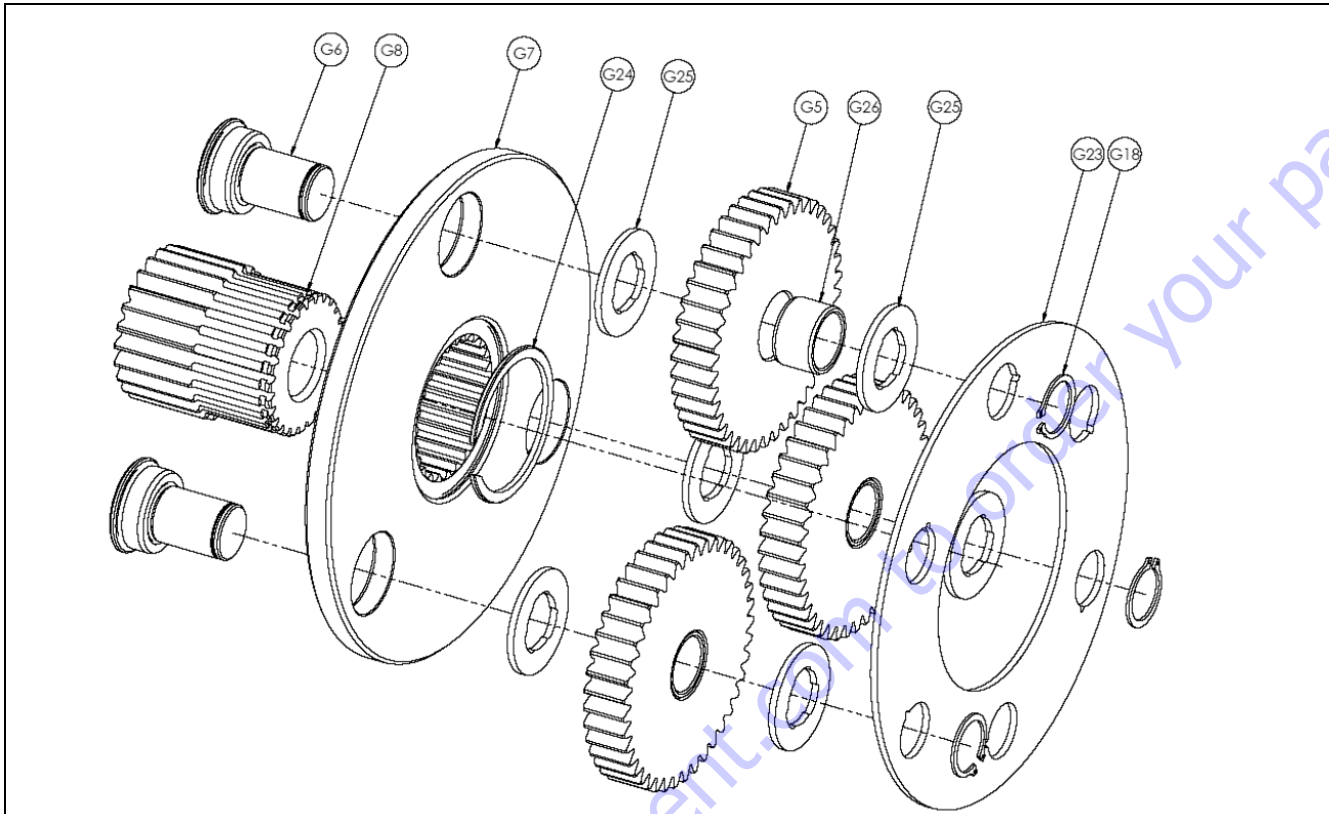

1. Use the **Input Planet Shaft (G6)** as a pressing tool to install the **Planet Bushing (G26)** into the bore of each **Planet Gear (G5)**. The shaft will help guide the bushing into the bore as well as prevent damage from the press.
2. Press three **Input Planet Shafts (G6)** into the three holes of the **Input Carrier (7)**. The head of the **Input Planet Shaft (G6)** needs to sit flush in the counter bore of the **Input Carrier (G7)** holes.
3. Insert **Output Sun Gear (G8)** into the splined bore of the **Input Carrier (G7)**. The gear tooth end of the **Output Sun Gear (G8)** should protrude in the opposite direction of the **Input Planet Shafts (G6)**.
4. Using retaining ring pliers, install the **Retaining Ring (G24)** into the groove of the **Output Sun Gear (G8)**. Make sure that the **Retaining Ring (G24)** is correctly seated in the groove and that the **Output Sun Gear (G8)** cannot be pulled out of the **Input Carrier (G7)**.
5. Place a **Thrust Washer (G25)** on each side of the **Input Planet Gear (5)**. Line up the bores as well as you can visually.
6. Place the **Input Planet Gear (G5)** and **Thrust Washers (G25)** onto the **Input Planet Shaft (G6)** sticking out from the **Input Carrier (G7)**.
7. Repeat 5 & 6 for the other 2 **Planet Gears (G5)**.
8. Put the **Thrust Plate (G23)** onto the three **Input Planet Shafts (G6)**. Use the three holes on the outermost bolt circle. The other three holes are for a different gear ratio.
9. Using the appropriate retaining ring pliers put a **Retaining Ring (G18)** into the groove of each **Input Planet Shaft (G6)**.

NOTE: Do not overstress the Retaining Rings (G18).

Motor, Brake, and Torque Hub Assembly

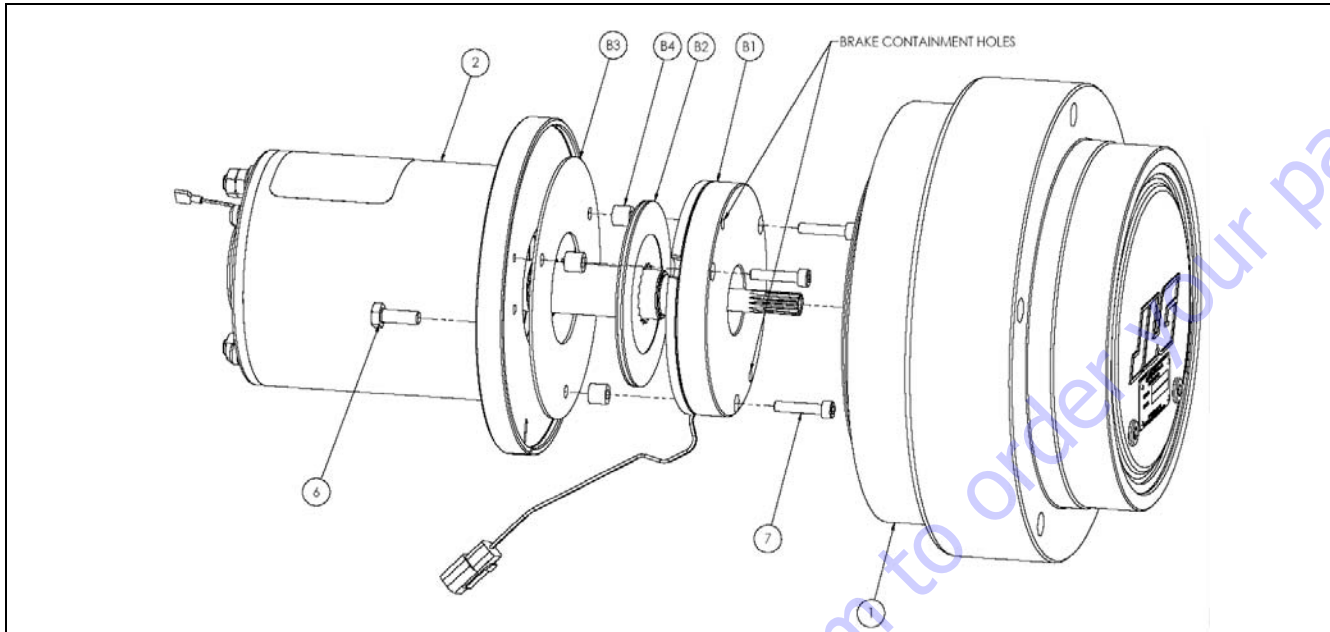

1. Place the **Motor (2)** shaft up on the bench.
2. Place the **Brake Friction Plate (B3)** onto face of the motor flange. Line up the three holes of the **Brake Friction Plate (B3)** with the tapped holes in the motor flange.
3. Install a wire tie around the brake leads and the motor housing. Position the wire tie so that it is approximately 2" back from the motor flange.
4. If the **Torque Hub (1)** is loose from the machine place it onto the bench with the cover side down. If the **Torque Hub (1)** is attached to the machine, perform the next step with extreme caution.

NOTICE

WHEN MOUNTING THE BRAKE FRICTION PLATE TO THE MOTOR FLANGE, CHECK THAT THE MOTOR HOUSING TO FLANGE MOUNTING BOLTS ARE NOT CONTACTING THE BRAKE FRICTION PLATE UNDERNEATH. CONTACT INTERFERENCE COULD CAUSE THE BRAKE FRICTION PLATE TO WARP WHEN TIGHTENED DOWN.

3. Place the **Brake Disc (B2)** on the motor shaft. Make sure the splines are properly lined up and the **Brake Disc (B2)** is down against the **Brake Friction Plate (B3)**.
4. Place the three **Spacers (B4)** so that they line up with the three holes in the **Brake Friction Plate (B3)**.
5. Carefully place the **Brake Housing (B1)** onto the **Spacers (B4)** so that the holes in the **Brake Housing (B1)** line up with the holes in the **Spacers (B4)**. Make sure that the wire leads coming out of the **Brake Housing (B1)** are lined up with the slot in the motor flange.
6. Install the three **Brake Bolts (7)** into the three holes in the **Brake Housing (B1)**. Tighten to 4-5 ft-lbs.
7. Remove and discard the 2 bolts in the **Brake Containment Holes**.
8. Pull the Brake Lead through the slot in the motor flange. Make sure the leads are all the way in the bottom of the slot.

NOTICE

BEFORE MOUNTING THE DRIVE MOTOR/BRAKE ASSEMBLY TO THE TORQUE HUB SPINDLE HUB BE CERTAIN THE BRAKE CAVITY INSIDE THE TORQUE HUB IS CLEAN AND FREE OF ANY OIL RESIDUE.

11. Slowly slide the **Motor (2)** into the **Torque Hub (1)**. Make sure that the end of the motor shaft does not damage the **Torque Hub (1)** lip seal.
12. Install the 2 **Motor Bolts (6)**. Tighten to 8-9 ft-lbs.
13. Apply a bead of silicone sealant to the slot in the motor flange where the brake leads are exiting.
14. Fill the **Torque Hub (1)** with oil per instructions.
15. The wheel drive is now ready to be installed onto the machine, reverse removal instructions.

NOTE: The motor may need to be rotated to line up the sun gear splines with the motor shaft splines.

3.6 PUMP MOTOR ASSEMBLY

General

The following is a complete tear down/reassembly of the machine's pump/motor assembly. No internal parts to the hydraulic pump are serviced by JLG except for a pump installation seal kit. The only internal serviceable part of the pump's electric motor is the motor brush kit.

NOTE: During reassembly of the pump/motor assembly, apply a liberal coat of JLG recommended hydraulic fluid to all seals and o-rings. Also keep all internal metal parts clean and coated with hydraulic fluid to prevent surface corrosion.

JLG recommends replacing all seals and o-rings when disassembling and reassembling the pump/motor unit.

NOTICE

DISCONNECT THE LEFT SIDE BATTERY (+) POSITIVE BATTERY TERMINAL BEFORE REMOVING THE PUMP/MOTOR FROM THE MACHINE.

Hydraulic Pressure Settings and Adjustment

Adjust system pressure so that platform will raise with maximum rated capacity in platform.

Perform pressure adjustment with oil at normal operating temperature. If pressure is set when oil is cold, platform may not raise rated load after oil has warmed.

The factory-recommended (initial) pressure setting is **1800 PSI**.

Turning adjustment screw **clockwise increases system pressure**. Turning screw **counterclockwise decreases system pressure**. Refer to Figure 3-7.

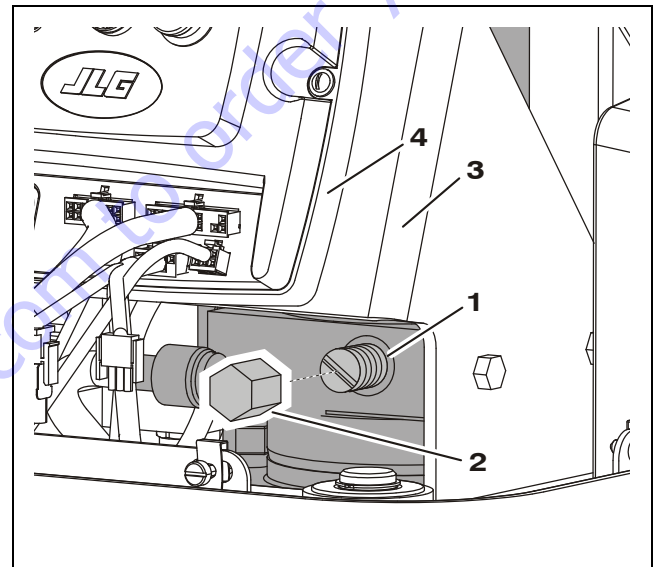

Figure 3-7. Hydraulic Pressure Adjustment Screw

- | | |
|------------------------------|---|
| 1. Pressure Adjustment Screw | 3. Pump/Ground Station Mounting Bracket |
| 2. Remove Adjust Screw Cap | 4. Ground Control Station |

NOTE: Machine front cover must be removed to access pump motor (shown).

Hydraulic Pressure Gauge Connection

CAUTION

ONLY OPEN HYDRAULIC SYSTEM LINES WITH THE MAST FULLY LOWERED TO RELIEVE PRESSURE IN THE SYSTEM. CAREFULLY LOOSEN REQUIRED FITTINGS. WEAR SAFETY PROTECTION EQUIPMENT WHEN WORKING WITH HYDRAULIC SYSTEMS.

NOTE: Refer to Section 5.8, *Hydraulic Line Disconnect Tool* for hydraulic line removal procedure.

1. Remove the hydraulic oil filter and install a t-fitting between the pump and the extend line to connect a hydraulic pressure gauge as shown in Figure 3-8., Typical Hydraulic Pressure Gauge Installation
2. Check, and if necessary, adjust the hydraulic pressure to initial settings shown in table at the beginning of this section.
3. Cycle the hydraulic system several times with the maximum load capacity in the platform, then recheck pressure setting. When pressure has stabilized, continue to the steps in the following section.

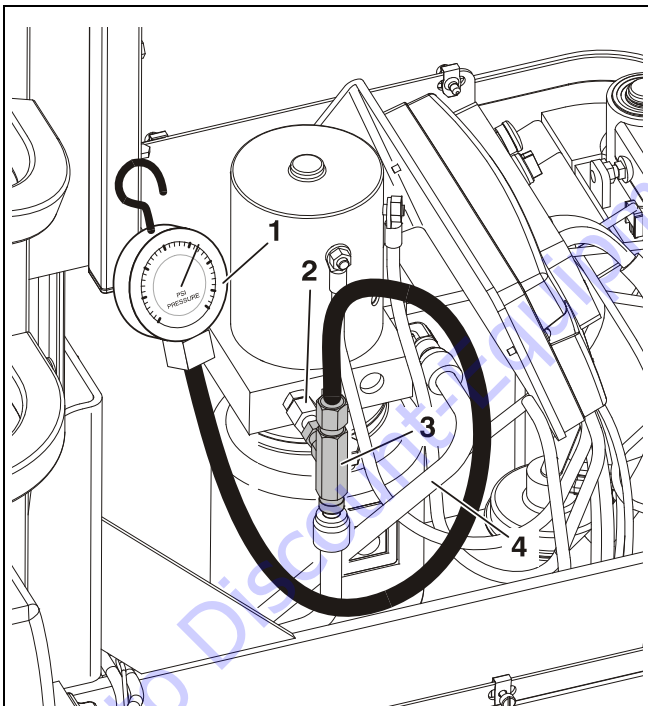

Figure 3-8. Typical Hydraulic Pressure Gauge Installation

- | | |
|----------------------------|-------------------------|
| 1. Pressure Gauge Assembly | 3. T-Fitting |
| 2. Cylinder Extend Line | 4. Cylinder Return Line |

After Filter Pressure Check

1. Reinstall the hydraulic oil filter and install a t-fitting between the hydraulic filter and the extend line to the cylinder.
2. Recheck the hydraulic pressure and compare with the previous readings when filter was removed. If a significant drop in pressure reading has occurred, replace the hydraulic filter and recheck the "After Filter" pressure reading.

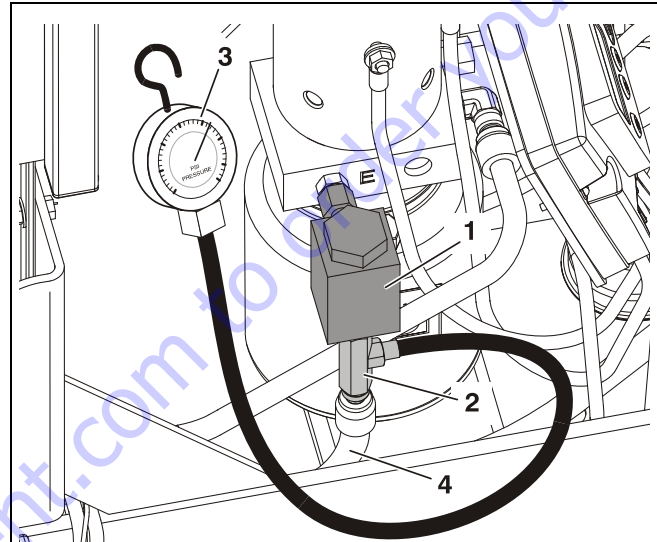

Figure 3-9. Typical Hydraulic Pressure Gauge Installation

- | | |
|-------------------------|----------------------------|
| 1. Hydraulic Oil Filter | 3. Pressure Gauge Assembly |
| 2. T-Fitting | 4. Cylinder Extend Line |

Pump Motor Assembly Removal

⚠ WARNING

ENSURE THE MAST IS FULLY LOWERED BEFORE REMOVING ANY HYDRAULIC LINES FROM THE PUMP UNIT. WEAR PROTECTIVE GEAR WHEN WORKING AROUND PRESSURIZED HYDRAULIC LINES. REMOVE CONNECTIONS CAREFULLY AND CAP ALL LINES AND PORTS WHEN DISCONNECTED.

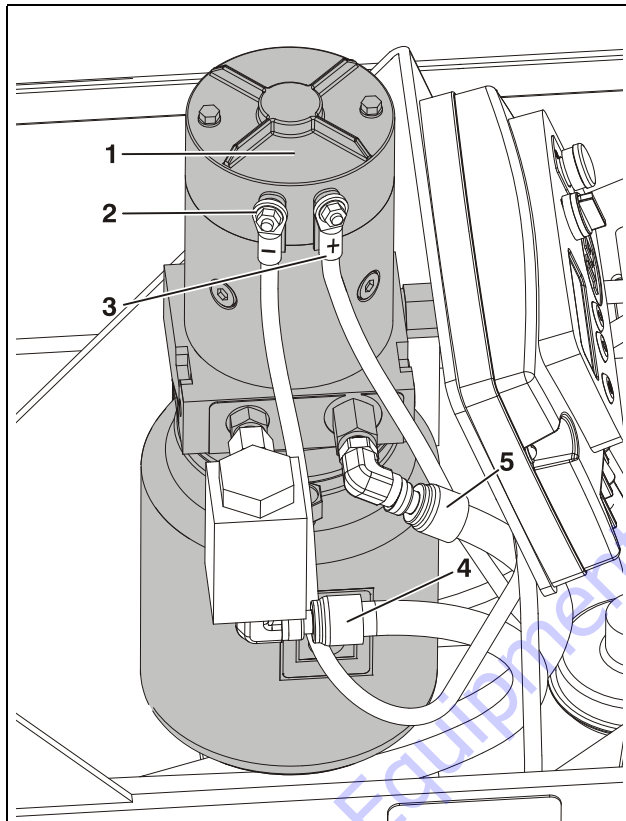

- 1. Hydraulic Pump/Motor/Reservoir Assembly
- 2. (-) Power Cable from Ground Control Station (a)
- 3. (+) Power Cable from Ground Control Station (a)
- 4. Hydraulic Extend Pressure Line to Lift Cylinder (b)
- 5. Hydraulic Return Line from Lift Cylinder (b)

NOTE: (a) Shown with protective cover removed.
 (b) Completely lower platform before loosening any hydraulic lines to remove any pressure remaining in the lines. Take proper caution and wear protective gear when opening a hydraulic line.

Once power cables and hydraulic lines are removed from this side of pump assembly, remove the mounting screws from the other side of the pump. Refer to the following illustration.

Pump Motor Assembly Installation

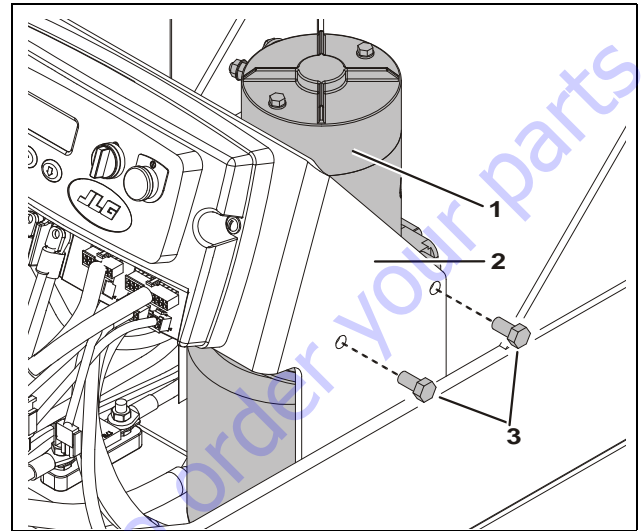

- 1. Hydraulic Pump/Motor/Reservoir Assembly
- 2. Pump/Ground Control Station Mounting Bracket
- 3. Pump Mounting Screws (a)

NOTE: (a) Apply Loctite #242 to screw threads before final assembly.

Before disassembling, be sure to mark or identify motor cover, housing, and valve body position per the following illustration:

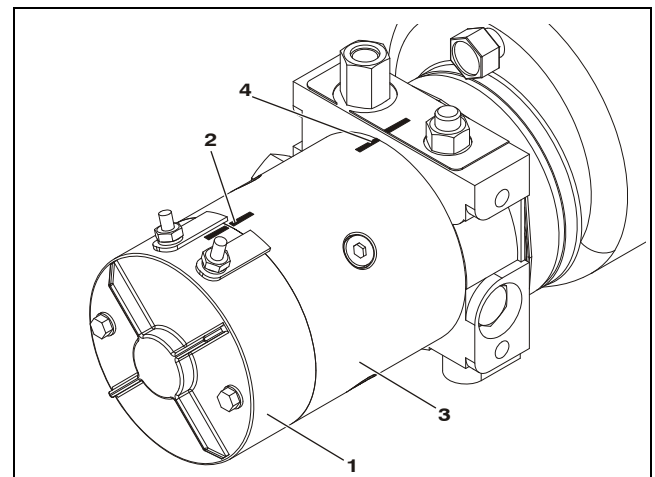

- 1. Motor Top Cover
- 2. Cover/Housing
- 3. Motor Housing
- 4. Housing/Motor Valve Body
- 5. Motor Valve Body

Motor/Brush Cover Removal

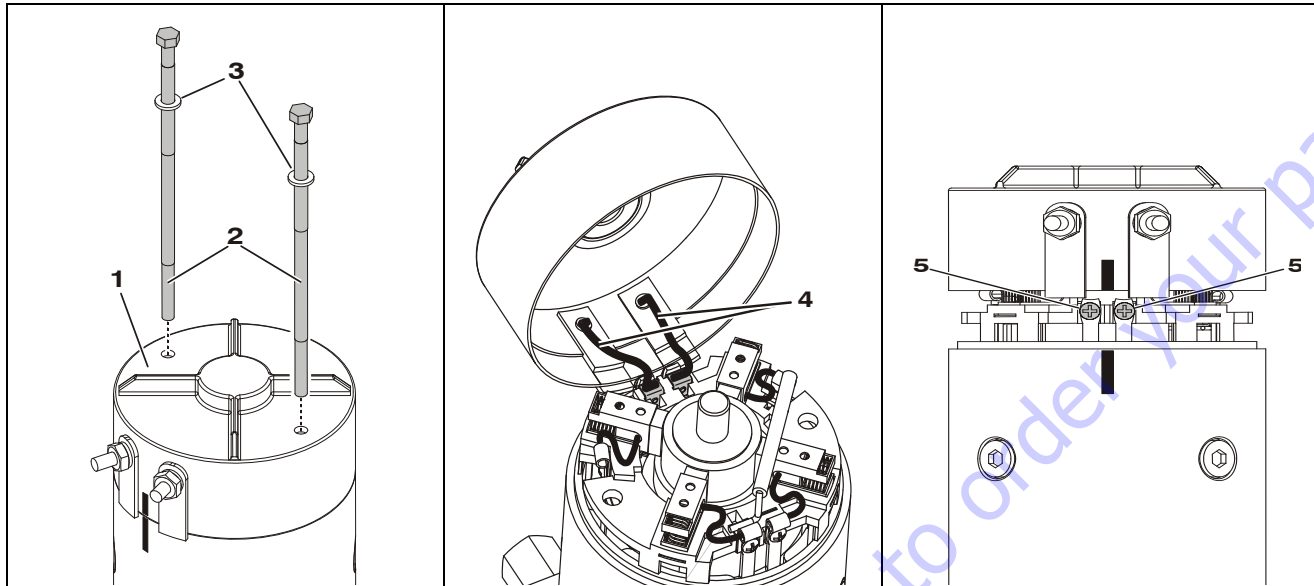

- 1. Motor/Brush Cover (a)
- 2. Cover Screws (b)

- 3. Washers
- 4. Power Leads to Lead Clips (Soldered)

- 5. Power Lead Clip Attach Screws

NOTICE

REMOVE THE MOTOR COVER CAREFULLY. THE (SHORT) POWER LEADS INSIDE THE COVER FROM THE (+/-) POSTS ARE SOLDERED TO ATTACH CLIPS, WHICH ARE FASTENED TO THE BRUSH CARRIER ASSEMBLY WITH SCREWS (ITEM-5). RAISE THE COVER STRAIGHT UP, REMOVE THE SCREWS, THEN HINGE THE COVER UP (SEE CENTER ILLUSTRATION) AND PRY THE CLIPS OFF OF THE BRUSH CARRIER ASSEMBLY TO COMPLETELY REMOVE THE MOTOR COVER.

NOTE: (a) Once cover screws are removed, it may be necessary to tap lightly around the edge of the top cover to separate it from the motor housing.
(b) These steel screws are threaded into the aluminum valve body. Do not overtighten.

Brush Carrier Assembly Removal

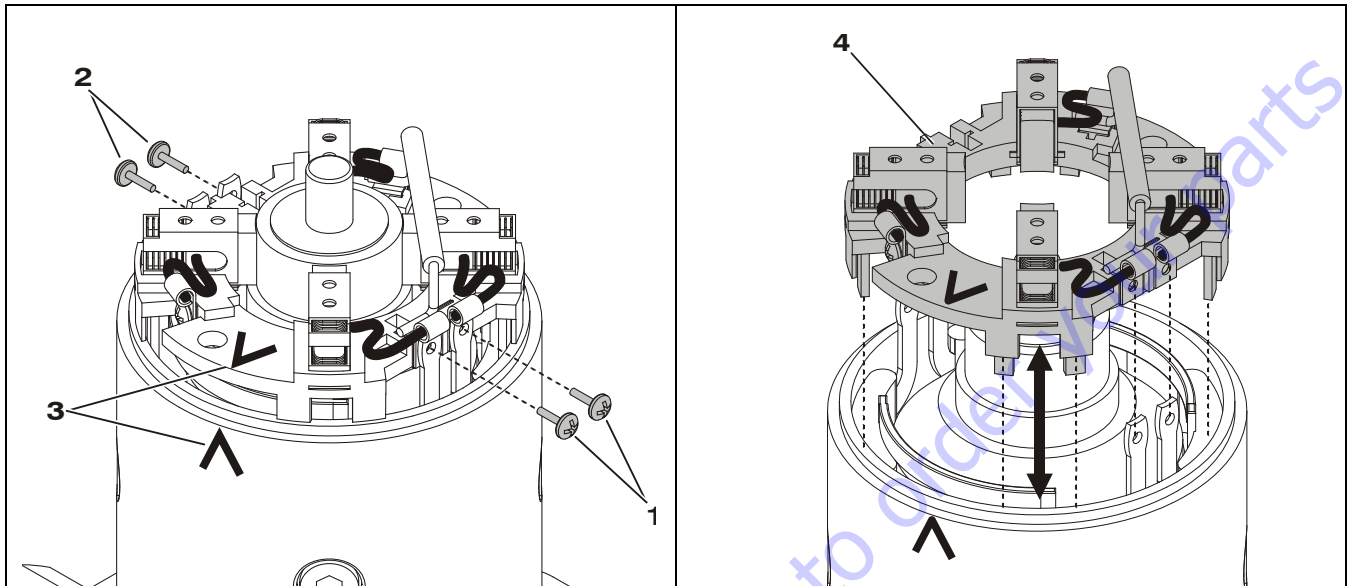

- 1. Stator/Brush Carrier Screws (Pump Rear)
- 2. Stator/Brush Carrier Screws (Pump Front) (a)

- 3. Mark Brush Carrier Position on Motor Housing
- 4. Brush Carrier Assembly

NOTE: (a) Removed previously with motor cover disassembly (shown for reference only).

Brush Assembly Removal

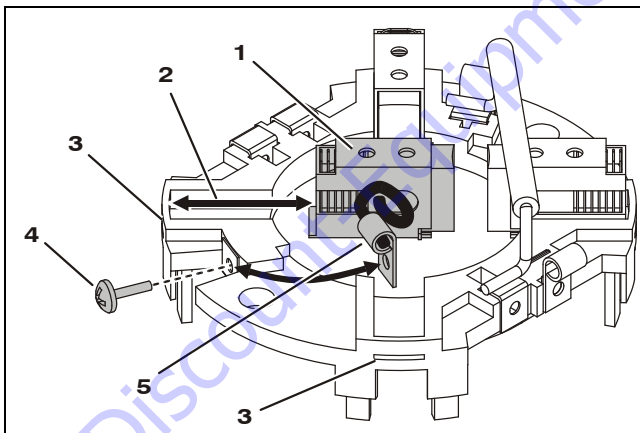

- 1. Brush Assembly (a)
- 2. Brush Carrier Socket
- 3. Brush Tab Slot
- 4. Brush Terminal Screw
- 5. Brush Attach Terminal

NOTE: (a) Slide brush assembly into socket until tab is in slot at rear of socket.

Tank Removal

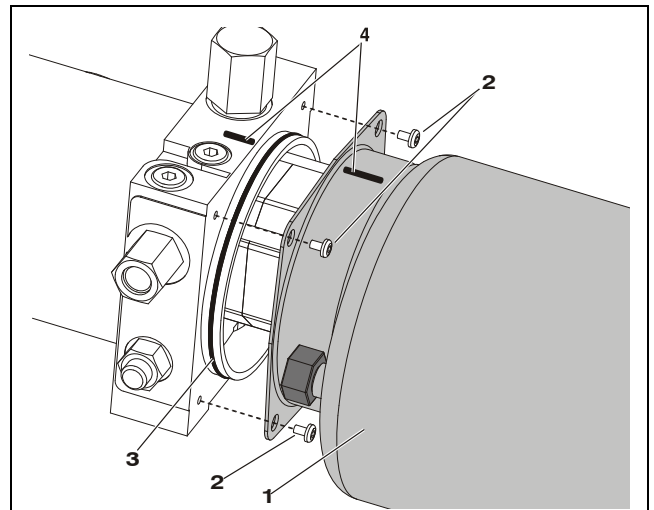

For reassembly reference, mark the tank and valve body.

- 1. Tank Assembly
- 2. Tank Screws
- 3. O-Ring Seal (a)
- 4. Reference Mark

NOTE: (a) Lubricate o-ring with clean hydraulic fluid before sliding tank over during installation.

Filter Screen Removal

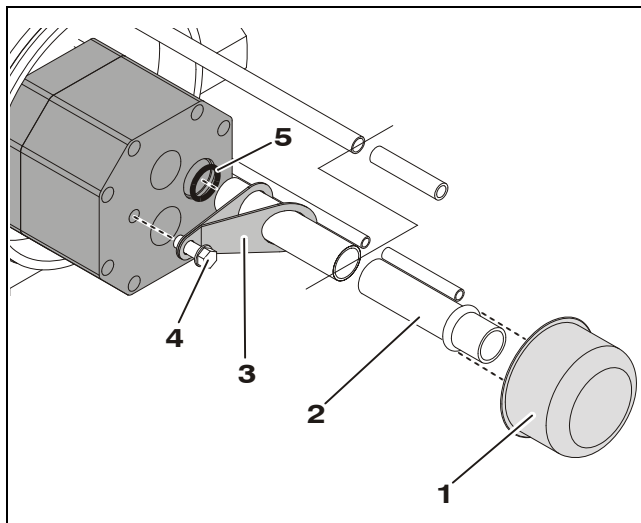

Requires removal of tank assembly.

- 1. Filter Screen
- 2. Pump Pick-Up Tube
- 3. Tube Retainer Clip
- 4. Tube Attach Screw
- 5. O-Ring

NOTE: Tubes shown shortened for illustrative purposes only.

Pump Removal

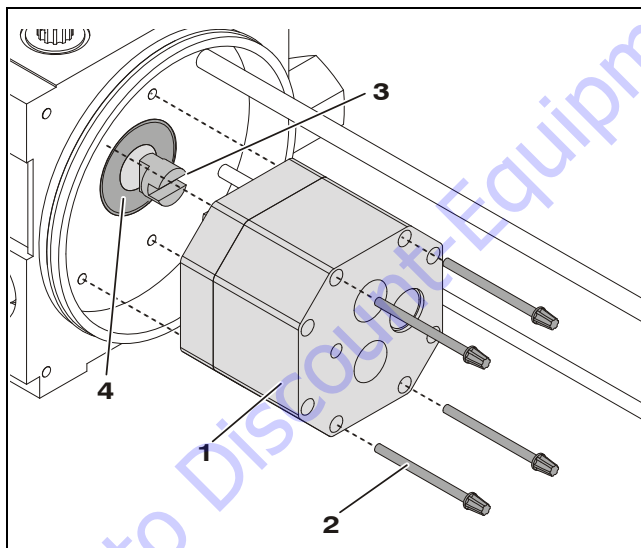

Requires removal of tank assembly and pump pick-up tube.

- 1. Pump Assembly
- 2. Pump Assembly Screws
- 3. Motor to Pump Coupler
- 4. Pump Shaft Bearing

Pressure Adjust Valve Removal

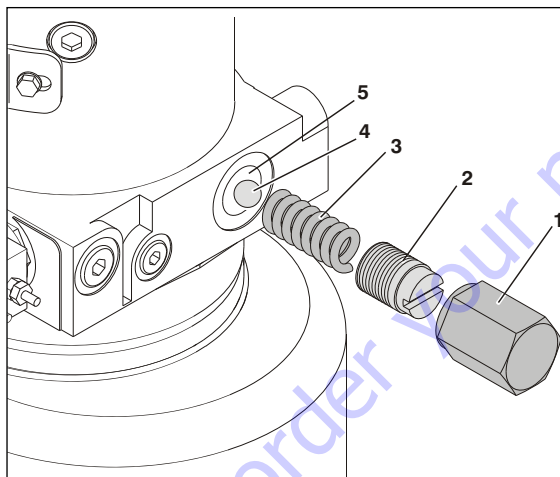

- 1. Adjust Valve Cap
- 2. Adjustment Screw
- 3. Valve Spring
- 4. Valve Ball
- 5. Adjust Valve Port

Pressure Check Valve Removal

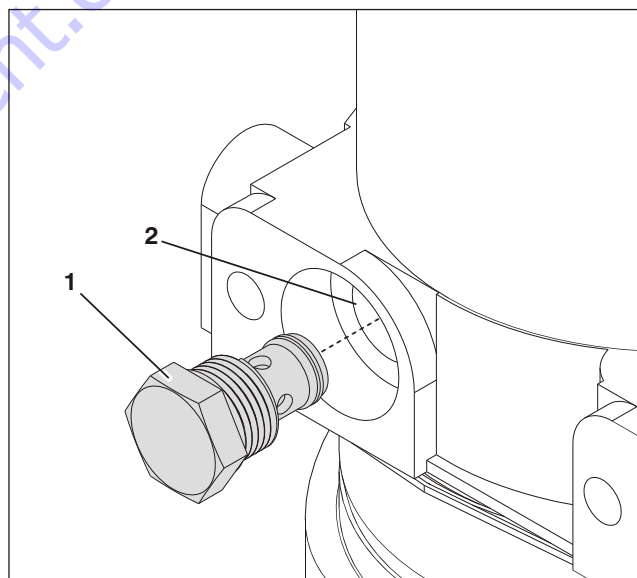

- 1. Check Valve Assembly
- 2. Check Valve Port

3.7 BATTERIES AND BATTERY CHARGER

Battery Condition Testing

NOTE: Batteries in storage should be kept at 12.5V or higher.

Before testing for battery condition, measure the open circuit voltage from each battery. If the voltage of the batteries differs by 0.3V or more, the lower voltage battery should be replaced.

Battery testing can be performed in two ways:

1. The batteries can be tested using a battery tester capable of testing 12V 100Ah AGM VRLA (Valve Regulated Lead Acid) batteries, using the instructions of the battery tester manufacturer.
2. If an appropriate battery tester is unavailable, batteries can be tested by fully charging them with charger that is installed in the machine. Then check battery voltage of each battery four hours after charging is complete. Batteries less than 12.72V should be replaced.

NOTE: If a faulty charger is suspected, the batteries can be charged using a charger that supplies 2.45V/cell. Charging should be terminated when the charge current drops below 1 A.

Battery Replacement

Replacement battery(s) must be of equivalent voltage and amperage output as the OEM battery(s) in order for the machine to operate to manufactured specifications. Battery replacement part weight must also be equivalent to OEM (65 lb/30 kg) per battery in order to maintain machine stability as manufactured.

WARNING

DO NOT REPLACE ITEMS CRITICAL TO STABILITY, SUCH AS BATTERIES, WITH ITEMS OF DIFFERENT WEIGHT OR SPECIFICATION. DO NOT MODIFY UNIT IN ANY WAY TO AFFECT STABILITY.

NOTICE

JLG MACHINES EQUIPPED WITH DELTA Q BATTERY CHARGERS ARE DESIGNED FOR THE BEST PERFORMANCE WITH OEM FACTORY APPROVED BATTERIES. APPROVED JLG REPLACEMENT BATTERIES ARE AVAILABLE THROUGH JLG'S AFTERMARKET PARTS DISTRIBUTION CENTERS OR JLG'S AFTERMARKET PROGRAMS. FOR ASSISTANCE WITH PROPER BATTERY REPLACEMENT, PLEASE CONTACT YOUR LOCAL JLG SUPPORT OFFICE.

BATTERIES APPROVED BY JLG HAVE BEEN TESTED FOR COMPATIBILITY WITH THE ALGORITHM PROGRAMMING OF THE DELTA Q BATTERY CHARGER TO OPTIMIZE BATTERY LIFE AND MACHINE CYCLE TIMES. THE USE OF NON APPROVED BATTERIES IN YOUR JLG EQUIPMENT MAY RESULT IN PERFORMANCE ISSUES OR BATTERY CHARGER FAULT CODES. JLG ASSUMES NO RESPONSIBILITY FOR SERVICE OR PERFORMANCE ISSUES ARISING FROM THE USE OF NON APPROVED BATTERIES.

Battery Installation (2-12V)

Some machines may be equipped with 2-12V batteries. Access to the batteries requires removal of the front cover and rear drive motor cover (refer to Section 3.2). Follow the same procedure to remove both batteries.

On installation, batteries sit in machine with the posts to the outside. Left side battery (+) POS post at front (shown below), right side battery (-) NEG post towards machine front.

WARNING

NEVER WORK UNDER AN ELEVATED PLATFORM UNTIL THE PLATFORM HAS BEEN SAFELY RESTRAINED FROM ANY MOVEMENT BY BLOCKING OR OVER-HEAD SLING.

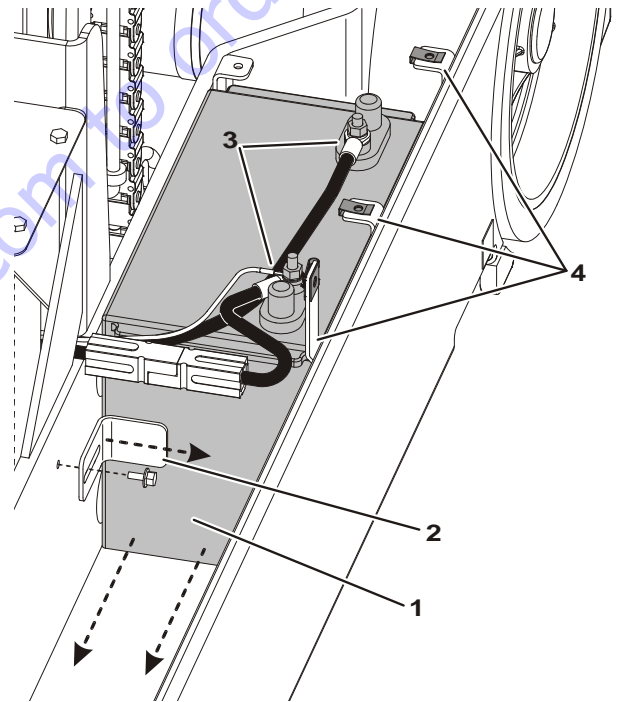

- | | |
|--------------------------------|-------------------------------------|
| 1. Battery (a) | 3. Battery Posts |
| 2. Hold-Down Bracket and Screw | 4. Drive Motor Cover Screw Brackets |

NOTE: (a) The carry deck support frame will need to be pivoted up at the rear to remove the batteries. Once hold-down bracket (2) is removed, remove the cables from the battery posts, slide battery forward to clear brackets (4). Then lift battery out of base frame.

Battery Installation (4-6V)

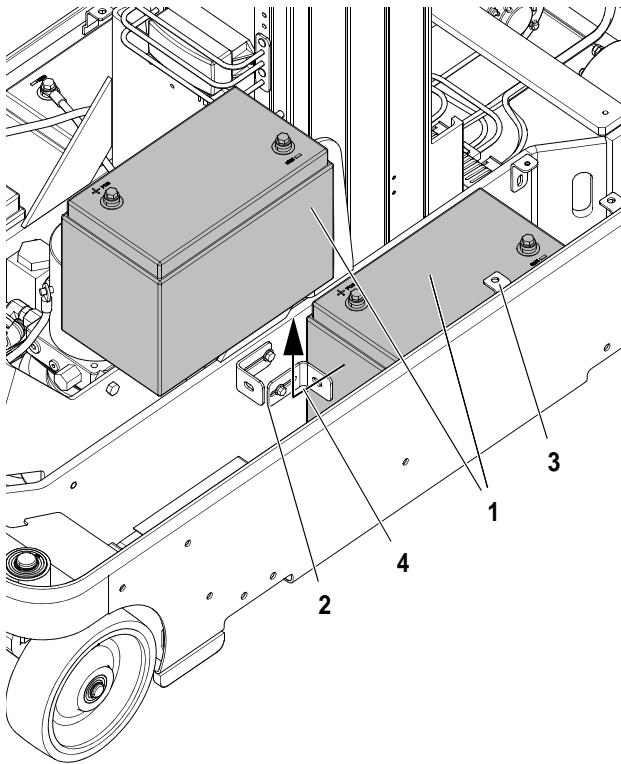

- 1. Batteries (Left Side)
- 2. Battery Hold-Down Brackets and Fasteners
- 3. Drive Motor Cover Screw Bracket
- 4. Move Rear Battery Forward and Lift Out

NOTE: The carry deck, support frame must be removed to remove the batteries. Once hold-down brackets (2) are removed, remove the cables from the batteries. Slide the rear battery forward to clear the bracket (3). Then lift battery out of base frame.

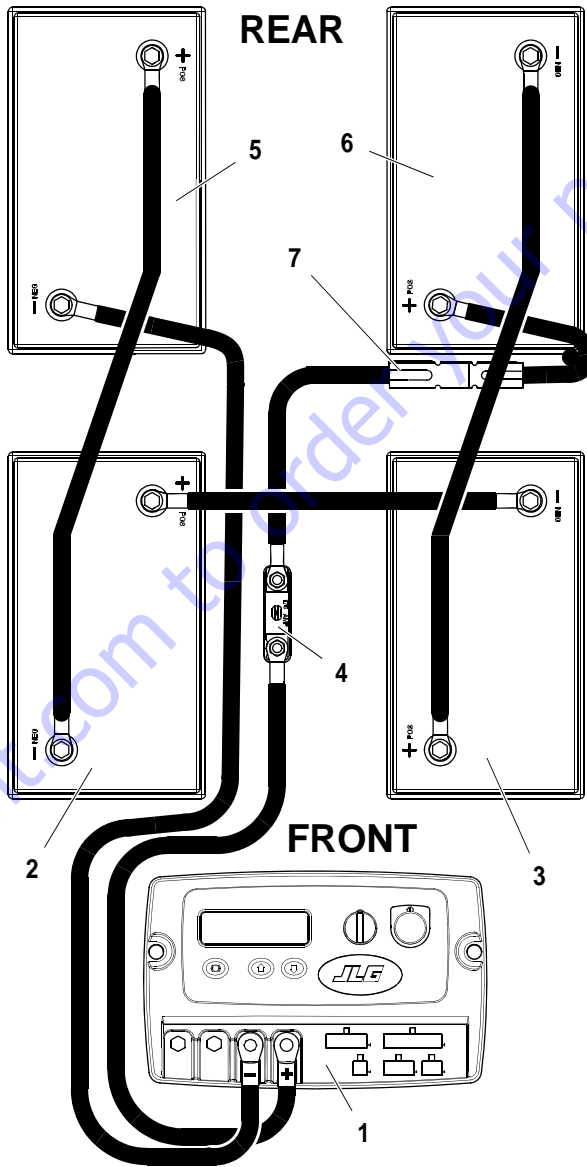

- 1. Ground Control Module
- 2. Right Front Battery
- 3. Left Front Battery
- 4. 175 Amp Inline Fuse
- 5. Right Rear Battery
- 6. Left Rear Battery
- 7. Battery Quick-Disconnect

NOTE: Label battery cables before removing to ensure proper installation. All other connections to Ground Control Module are the same as in Figure 4-2.

Battery Charge LED Indicator on Platform Control Console

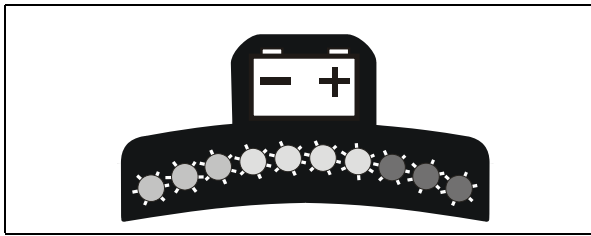

On normal power-up and operation this series of ten (10) LEDs visually indicates the amount of charge remaining in the batteries.

The number of LEDs lit will change depending on the level of charge in the batteries.

- (+) All Three GREEN LEDs lit up indicate maximum battery charge.
- Four YELLOW LEDs indicate a two thirds to one third battery charge remaining.
- (-) Three RED LED's lit indicate minimum battery charge remaining. The machine will continue to operate at this charge level but will begin to indicate battery low voltage warning indicators.

Battery Low Voltage Warning Indicators

The Platform Control Console and Ground Control Station indicate battery low voltage at three Warning Levels (refer to Table 3-2).

Table 3-2. Battery Low Voltage Warning Indicators

WARNING LEVEL	INDICATOR LOCATION		RESULT	ACTION REQUIRED TO CLEAR FAULT
	PLATFORM CONTROL LED	GROUND CONTROL LCD		
LEVEL 1			<ul style="list-style-type: none"> • 3 LEDs/bars flashing with an audible beep. • Machine will operate - no control functions locked out. 	Charge batteries to a level of four LEDs/BARS or more before operating.
LEVEL 2			<ul style="list-style-type: none"> • 2 LEDs/bars flashing with an audible beep. • Platform lift up function is locked out. 	Charge batteries for a minimum of four continuous hours or more, or eight LEDs/BARS lit before operating. (a)
LEVEL 3			<ul style="list-style-type: none"> • 1 LED/bar flashing with an audible beep. • Drive and platform lift up functions locked out. 	Charge batteries for a minimum of four continuous hours or more, or eight LEDs/BARS lit before operating. (a)

NOTE: (a) To maximize battery life, it is recommended that the factory supplied batteries be charged continuously for a minimum of 4 hours or until 8 bars are lit on the ground station LCD Display before operating the machine. When drained to Warning Level 2, batteries must be charged until 8 bars are lit on the ground station LCD display to clear the fault code.

Battery Charging Status Indicators

The battery charging status LED indicators are located next to the charger AC input receptacle on the rear bumper of the machine. This LED indicator set is plugged directly into a connector on the back of the battery charger and indicates current charging status.

When first plugged in, the charger will automatically turn on and go through a short LED indicator self-test (all LED's will flash in an up-down sequence for two seconds), then charging will begin.

The YELLOW 'CHARGING' LED will turn on and a trickle current will be applied until a minimum voltage is reached.

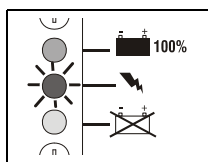

CHARGING
YELLOW(MIDDLE) LED ON
Charge Incomplete

Once a minimum battery voltage of 2 volts per cell is detected, the charger will enter the bulk charging constant-current stage and the YELLOW 'CHARGING' LED will remain on. The length of charge time will vary by how large and how depleted the battery pack is, the input voltage (the higher, the better), and ambient temperatures (the lower, the better). If input AC voltage is low (below 104VAC), then charging power will be reduced to avoid high input currents. If ambient temperature is too high, then the charging power will also be reduced to maintain a maximum internal temperature.

When the GREEN 'CHARGED' LED turns on, the batteries are completely charged.

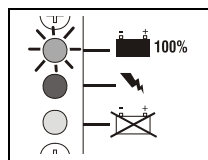

CHARGE COMPLETE
GREEN (TOP) LED ON
100% Complete

The charger may now be unplugged from AC power (always pull on plug and not cord to reduce risk of damage to the cord). If left plugged in, the charger will automatically restart a complete charge cycle if the battery pack voltage drops below a minimum voltage or 30 days has elapsed.

If a fault occurred anytime during charging, a fault indication is given by flashing the RED 'FAULT' LED with a code corresponding to the error.

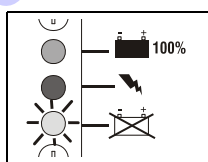

CHARGING PROBLEM
RED (BOTTOM) LED ON
See Flash Codes following

Several possible conditions may generate errors. Some errors are serious and require human intervention to first resolve the problem and then to reset the charger by interrupting AC power for at least 10 seconds. Others may be simply transient and will automatically recover when the fault condition is eliminated. To indicate which error occurred, the RED 'FAULT' LED will flash a number of times, pause, and then repeat.

[1 FLASH] Battery Voltage High: auto-recover. Indicates a high battery pack voltage.

[2 FLASH] Battery Voltage Low: auto-recover. Indicates either a battery pack failure, battery pack is not connected to charger, or battery volts per cell is less than 0.5 VDC. Check the battery pack and battery pack connections.

[3 FLASH] Charge Timeout: Indicates the battery did not charge within the allowed time. This could occur if the battery is of a larger capacity than the algorithm is intended for. It can also occur if the battery pack is damaged, old, or in poor condition. In unusual cases it could mean charger output is reduced due to high ambient temperature.

[4 FLASH] Check Battery: Indicates the battery pack could not be trickle charged up to the minimum 2 volts per cell level required for the charge to be started. This may also indicate that one or more cells in the battery pack are shorted or damaged.

[5 FLASH] Over-Temperature: auto-recover. Indicates charger has shutdown due to high internal temperature which typically indicates there is not sufficient airflow for cooling – see step 1 of Installation Instructions. Charger will restart and charge to completion if temperature is within accepted limits.

[6 FLASH] QuiQ Fault: Indicates that the batteries will not accept charge current, or an internal fault has been detected in the charger. This fault will nearly always be set within the first 30 seconds of operation. Once it has been determined that the batteries and connections are not faulty, and Fault 6 is again displayed after interrupting AC power for at least 10 seconds, the charger must be brought to a qualified service depot.

Battery Charger Maintenance

- Ensure charger connections to battery terminals are tight and clean.
- Do not expose charger to oil or to direct high pressure water spraying when cleaning vehicle.

NOTICE

DO NOT ATTEMPT TO DISASSEMBLE THE BATTERY CHARGER IF MACHINE IS STILL UNDER WARRANTY. OPENING THE BATTERY CHARGER WHILE THE MACHINE IS UNDER WARRANTY WILL VOID THE CHARGER WARRANTY. IF UNDER WARRANTY REQUEST A REPLACEMENT CHARGER FROM THE FACTORY.

Battery Charger Check/Change Charging Algorithm

The charger comes pre-loaded with these nine algorithms. JLG recommends using OEM batteries. Contact the battery manufacturing dealer for the correct algorithm setting if it is not included on this chart.

ALGORITHM SETTING	BATTERY TYPE
1	Trojan T105
2	Trojan T105 Tapped
3	T105 DV/DT CP
4	US Battery USB2200
5	Trojan 30/31XHS
6	DEKA 8G31 Gel
7	J305 DV/DT CP
8	Concorde 10xAH AGM
23	Douglas AGM Flooded (Default)
43	US AGM 6V27 (210AH)

Each time AC power is applied with the battery pack NOT CONNECTED, the charger enters an algorithm select/display mode for approximately 11 seconds. Repeat until desired algorithm # is displayed. A 30 second time-out is extended for every increment. During this time, the current algorithm # is indicated on the YELLOW 'CHARGING' LED. A single digit algorithm # is indicated by the number of blinks separated by a pause. A two digit algorithm # is indicated by number of blinks for the first digit followed by a short pause, then the number of blinks for the second digit followed by a longer pause.

To check/change the charging algorithm:

1. Disconnect charger positive connector from battery pack. Apply AC power. After the LED test, the Algorithm # will display for 11 seconds.
2. To change algorithm, touch connector during the 11 second display period to the battery pack's positive terminal for 3 seconds and then remove – the Algorithm # will advance after 3 seconds. Repeat until desired Algorithm # is displayed. A 30 second timeout is extended for every increment. Incrementing beyond last Algorithm moves back to first Algorithm. After desired Algorithm # is displayed, touch the charger connector to the battery positive until the output relay is heard to click (~10 seconds) – algorithm is now in permanent memory.
3. Remove AC power from the charger and reconnect the charger positive connector to the battery pack. It is highly recommended to check a newly changed algorithm by repeating the above steps 1 and 3.

Battery Charger Removal/Installation

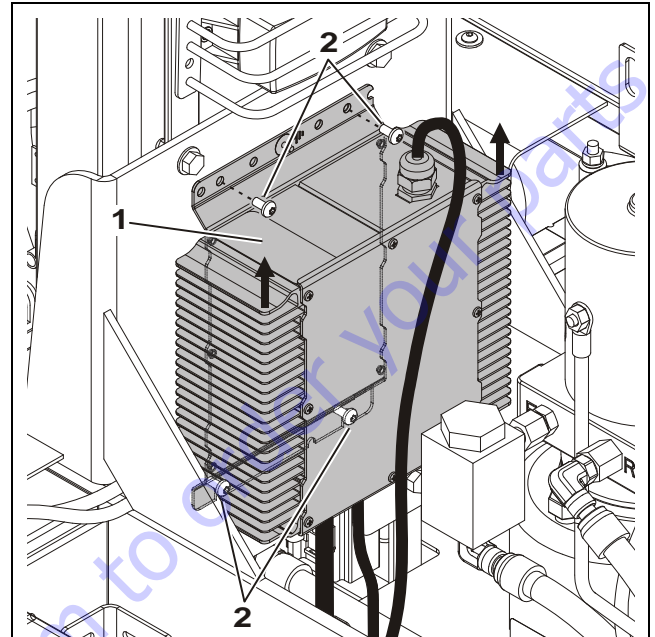

1. Battery Charger Assembly.

2. Charger Attach Screws (4): remove two on top, loosen two on bottom

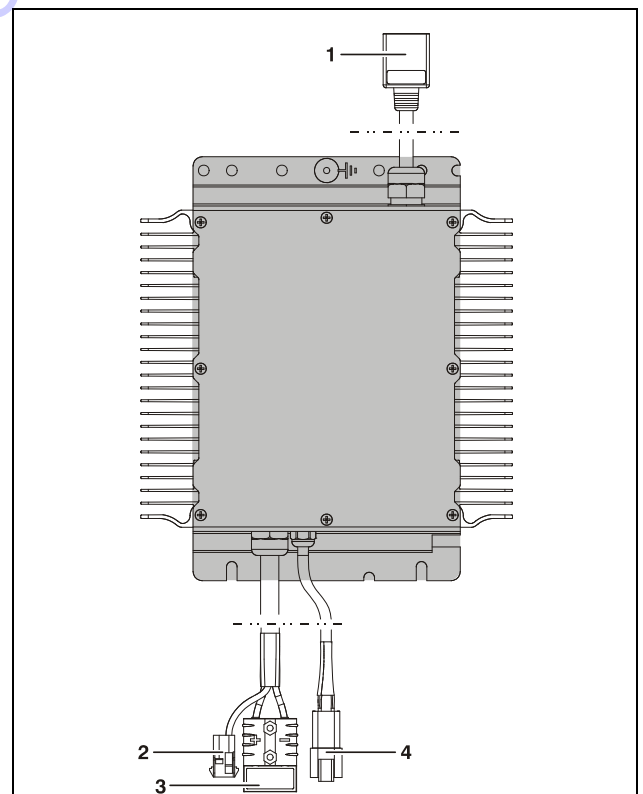

1. To AC 120/220Volt Input Socket (On Rear Bumper)

2. Drive Cut-Out Interlock Harness to P2 Connector on Ground Control Module

3. DC Voltage Output to Battery +/- Posts

4. To Charging Status LED Indicators (On Rear Bumper)

PARTS FINDER

**Search Website
by Part Number**



**Search Manual
Library For Parts
Manual & Lookup Part
Numbers – Purchase
or Request Quote**

Search Manuals

Enter your information to search for manuals and parts.

* Brand:

* Model:

* Serial:

* Part Number:

SEARCH

**Can't Find Part or
Manual? Request Help
by Manufacturer,
Model & Description**

Parts Order Form

Please fill in the following information:

Manufacturer:

Model:

Description:

Quantity:

Part Number:

Part Name:

Part Description:

Part Location:

Part Condition:

Part Status:

Part Material:

Part Color:

Part Weight:

Part Dimensions:

Part Price:

Part Lead Time:

Part Availability:

Part Notes:

Part Comments:

Part Attachments:

Part Images:

Part Videos:

Part Documents:

Part Links:

Part Other:

Part Contact:

Part Phone:

Part Email:

Part Address:

Part City:

Part State:

Part Zip:

Part Country:

Part Currency:

Part Tax:

Part VAT:

Part GST:

Part HST:

Part PST:

Part QST:

Part Other Tax:

Part Total:

Part Net:

Part Tax Inclusive:

Part Tax Exclusive:

Part Net Total:

Part Tax Total:

Part Grand Total:

Part Payment Method:

Part Payment Terms:

Part Payment Schedule:

Part Payment Reference:

Part Payment Contact:

Part Payment Phone:

Part Payment Email:

Part Payment Address:

Part Payment City:

Part Payment State:

Part Payment Zip:

Part Payment Country:

Part Payment Currency:

Part Payment Tax:

Part Payment VAT:

Part Payment GST:

Part Payment HST:

Part Payment PST:

Part Payment QST:

Part Payment Other Tax:

Part Payment Total:

Part Payment Net:

Part Payment Tax Inclusive:

Part Payment Tax Exclusive:

Part Payment Net Total:

Part Payment Tax Total:

Part Payment Grand Total:

Part Payment Method:

Part Payment Terms:

Part Payment Schedule:

Part Payment Reference:

Part Payment Contact:

Part Payment Phone:

Part Payment Email:

Part Payment Address:

Part Payment City:

Part Payment State:

Part Payment Zip:

Part Payment Country:

Part Payment Currency:

Part Payment Tax:

Part Payment VAT:

Part Payment GST:

Part Payment HST:

Part Payment PST:

Part Payment QST:

Part Payment Other Tax:

Part Payment Total:

Part Payment Net:

Part Payment Tax Inclusive:

Part Payment Tax Exclusive:

Part Payment Net Total:

Part Payment Tax Total:

Part Payment Grand Total:

Discount-Equipment.com is your online resource for quality parts & equipment.

Florida: **561-964-4949** Outside Florida TOLL FREE: **877-690-3101**

Need parts?

Click on this link: <http://www.discount-equipment.com/category/5443-parts/> and choose one of the options to help get the right parts and equipment you are looking for. Please have the machine model and serial number available in order to help us get you the correct parts. If you don't find the part on the website or on once of the online manuals, please fill out the request form and one of our experienced staff members will get back to you with a quote for the right part that your machine needs.

We sell worldwide for the brands: Genie, Terex, JLG, MultiQuip, Mikasa, Essick, Whiteman, Mayco, Toro Stone, Diamond Products, Generac Magnum, Airman, Haulotte, Barreto, Power Blanket, Nifty Lift, Atlas Copco, Chicago Pneumatic, Allmand, Miller Curber, Skyjack, Lull, Skytrak, Tsurumi, Husquvarna Target, , Stow, Wacker, Sakai, Mi-T- M, Sullair, Basic, Dynapac, MBW, Weber, Bartell, Bennar Newman, Haulotte, Ditch Runner, Menegotti, Morrison, Contec, Buddy, Crown, Edco, Wyco, Bomag, Laymor, Barreto, EZ Trench, Bil-Jax, F.S. Curtis, Gehl Pavers, Heli, Honda, ICS/PowerGrit, IHI, Partner, Imer, Clipper, MMD, Koshin, Rice, CH&E, General Equipment, ,AMida, Coleman, NAC, Gradall, Square Shooter, Kent, Stanley, Tamco, Toku, Hatz, Kohler, Robin, Wisconsin, Northrock, Oztec, Toker TK, Rol-Air, Small Line, Wanco, Yanmar

SECTION 4. CONTROL COMPONENTS

4.1 CONTROL COMPONENTS OVERVIEW

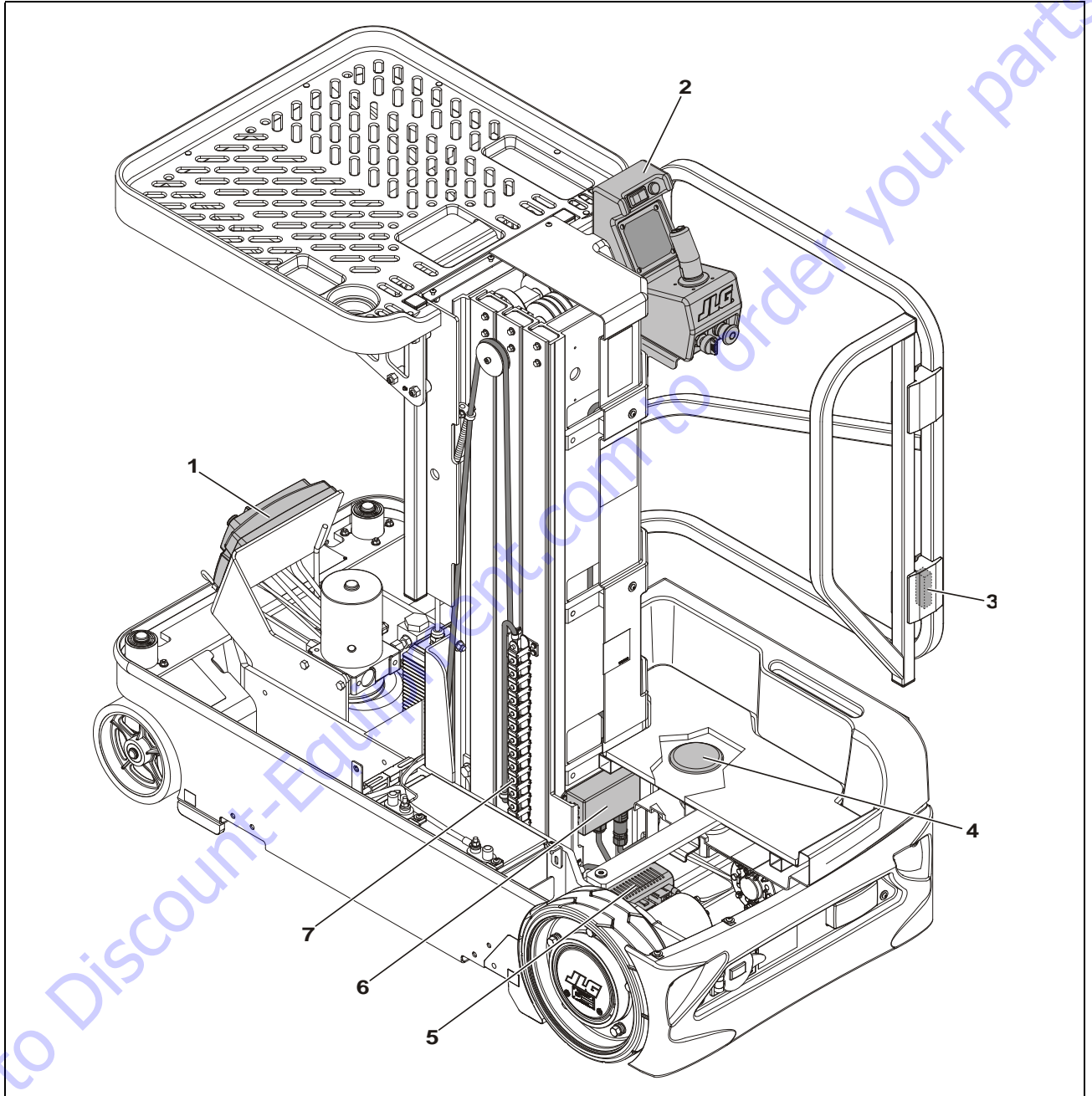
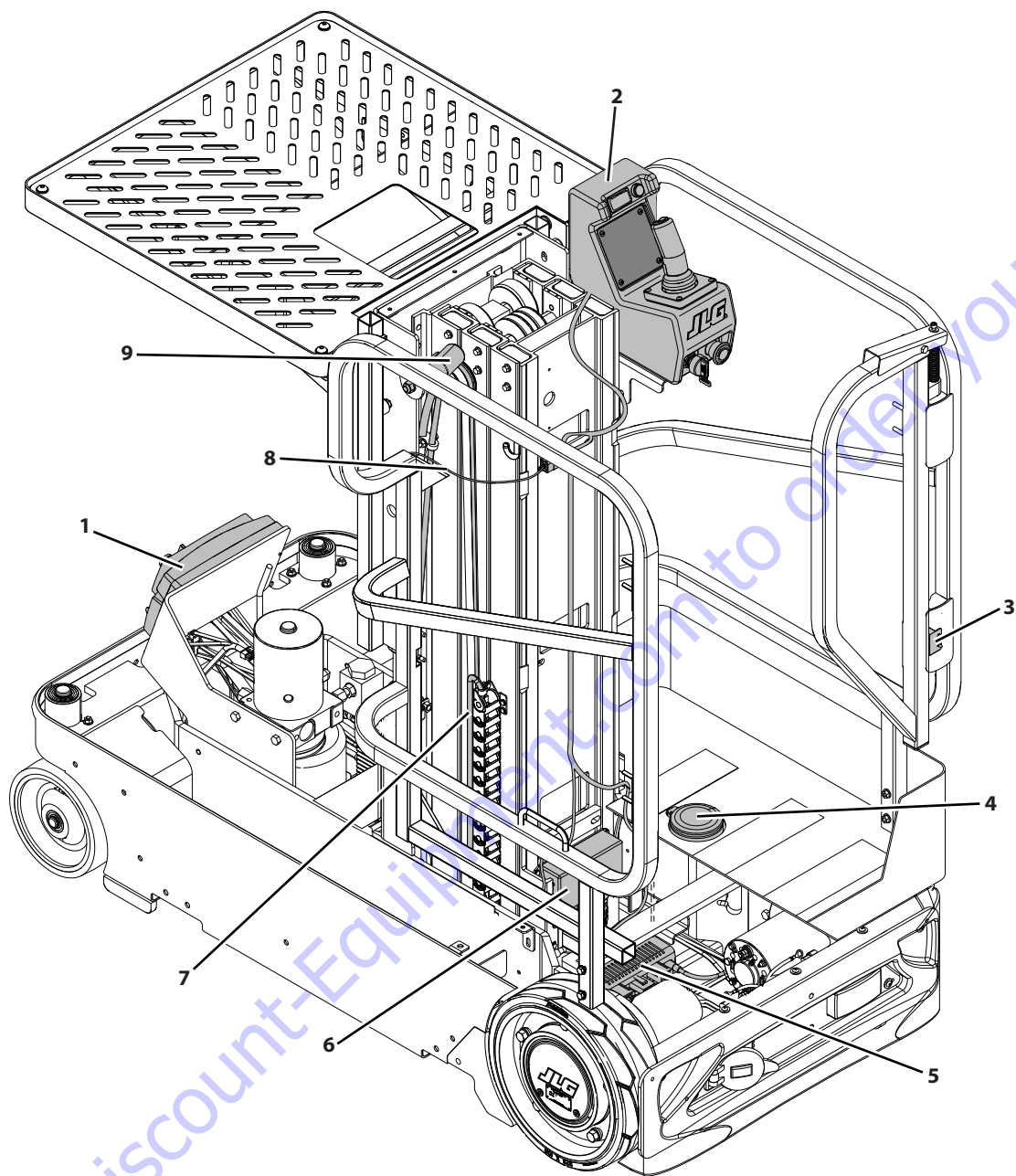

Figure 4-1. Control Components Location (Prior to SN 0130032507)

- | | | |
|---------------------------------------|----------------------------------|--|
| 1. Ground Control Station | 4. Platform Footswitch Interlock | 7. Platform Junction Box to Ground Control Harness |
| 2. Platform Control Console | 5. Traction Control Module | * Mounted inside lower gate hinge left and right side. |
| 3. Platform Gate Interlock Switches * | 6. Platform Junction Box | |

Note: Some components hidden or removed for clarity.



- 1. Ground Control Station
- 2. Platform Control Console
- 3. Platform Gate Interlock Switches *
- 4. Platform Footswitch Interlock
- 5. Traction Control Module
- 6. Platform Junction Box

- 7. Platform Junction Box to Ground Control Harness
 - 8. Left Hand Lift Cable (routed inside platform rails)
 - 9. Left Hand Lift
- * Mounted inside lower gate hinge left and right side

Note: Some components hidden or removed for clarity

Figure 4-2. Control Components Location (SN 0130032507 to Present)

4.2 CONTROL COMPONENTS INSTALLATION

NOTICE

BEFORE REMOVING ANY COMPONENT FROM THE ELECTRICAL SYSTEM, DISCONNECT THE POSITIVE TERMINAL FROM THE LEFT SIDE BATTERY.

Ground Control Module

The face of the Ground Control Module is visible from the front of the machine and is located under the front cover. It is mounted to a bracket on the base frame in front of the hydraulic pump.

All electrical components on the machine operate directly or indirectly through the Ground Control Module. The module is currently programmed at the factory with the machines operating profile. If replacing a Ground Control Module the new module may require some programming to enable any optional equipment.

For servicing and programming information for the Ground Control Module, refer to Section 4.3 and Section 4.4.

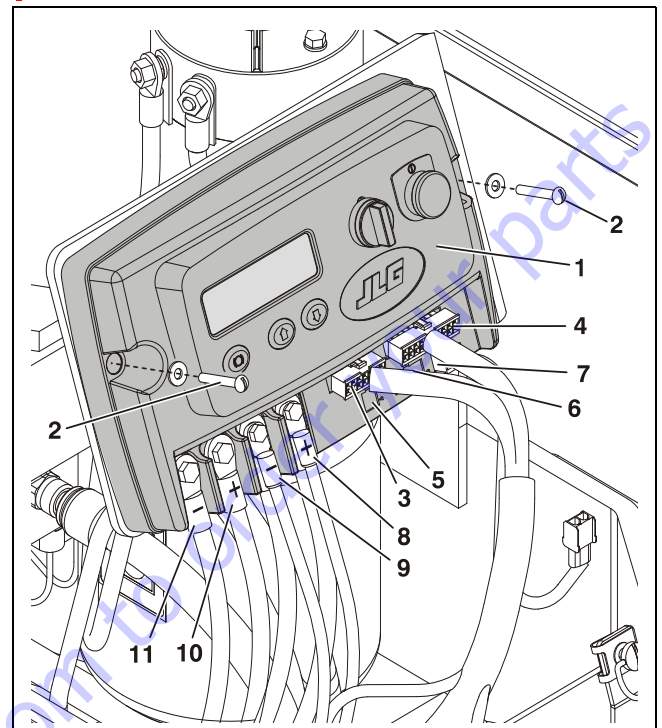

Figure 4-3. Ground Control Module Installation

- | | |
|----------------------------------|--|
| 1. Ground Control Station Module | 8. From Inline Fuse (Battery +) and To Traction Control Module (+) |
| 2. Mounting Screws/Washers (a) | 9. From Battery (-) and To Traction Control Module (-) |
| 3. P1 Connector (b) | 10. To (+) Terminal on Hydraulic Pump |
| 4. P2 Connector (b) | 11. To (-) Terminal on Hydraulic Post |
| 5. P3 Connector (b) | |
| 6. P4 Connector (b) | |
| 7. P5 Connector (b) | |

Note: (a) Apply Loctite #242 to screw threads on final assembly.
(b) To help seal unit from dust and moisture, apply electrical contact grease CG60 (JLG P/N 3020038) to all electrical connectors before assembly.

Traction Control Module Installation

The Traction Control Module is mounted to the base frame beneath the platform under the drive motor cover.

This module controls the voltage to the drive motors as regulated by the Ground Control Module from signals received from the joystick on the Platform Control Module.

There are no internal parts serviced on this module.

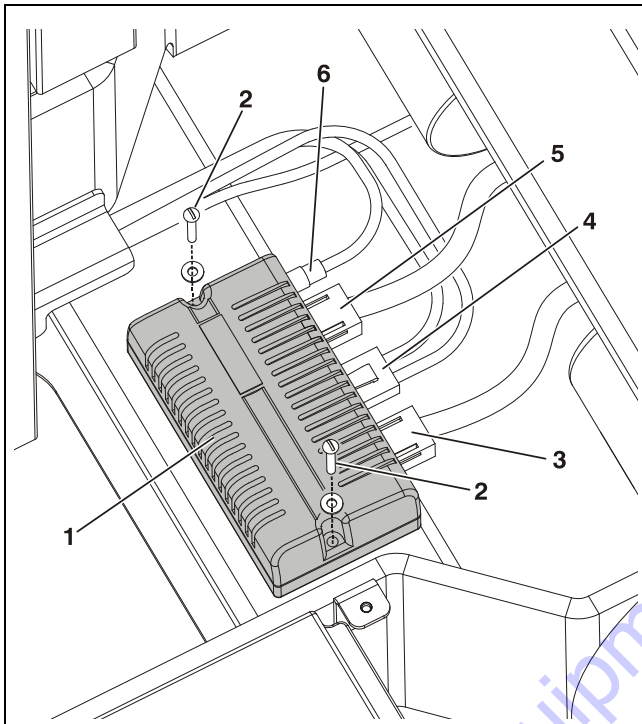

1. Traction Control Module
2. Module Mounting Screws/Washers (a)
3. Left Drive Motor Power Cable
4. +/- Power From Ground Control Station
5. Right Drive Motor Power Cable
6. Communication Cable from Ground Control Station

Note: (a) Apply Loctite #242 to mounting screw threads on final assembly.

Platform Control Console Installation

The platform control console is located in the platform and mounted on the right side of the mast assembly.

For servicing information, refer to Section 4.5.

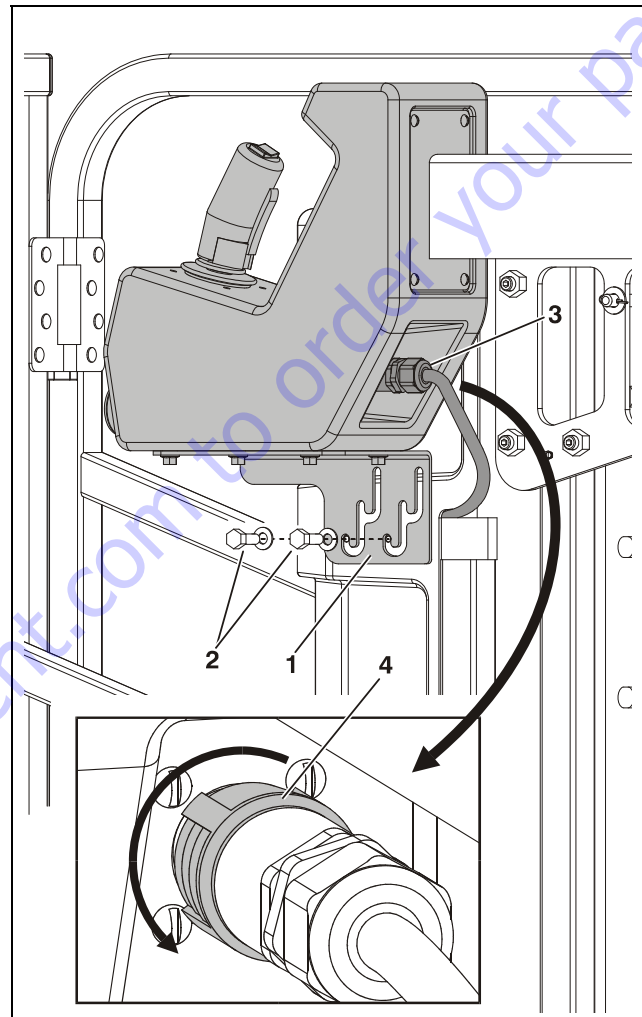

1. Console (3 Level) Mounting Bracket
2. Mounting Bracket Screws and Washers
3. Platform Console to Junction Box Harness (a)
4. Harness Connector - Removal Nut

Note: (a) The other end of this harness is plugged into the platform junction box mounted to the mast under the platform. From the platform console, the harness runs under the mast cover, is tie-strapped to the top platform attach support, and runs inside the mast down and out the bottom rectangular hole. Then it runs down along the outside of the mast and through a large hole in the mast to the platform junction box.

Platform Junction Box Installation

All the platform mounted switches and controls connect to the platform junction box before running to the Ground Control Module (P2, P3, and P4 Connectors). The Ground Control Module Harness is attached to the side of the mast assembly.

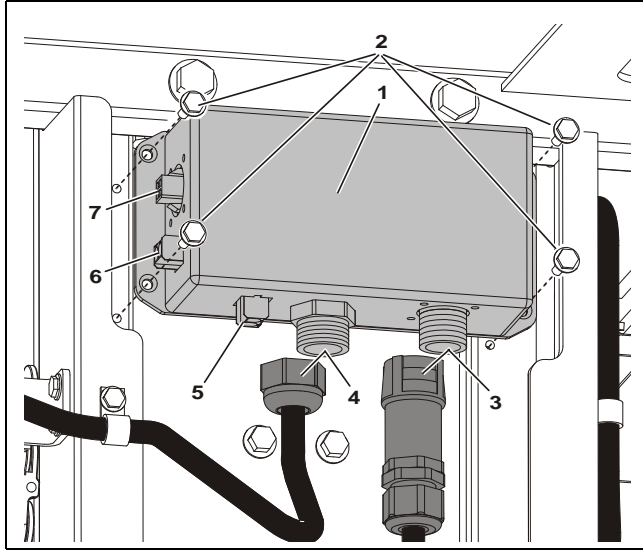

- | | |
|---|--|
| 1. Platform Junction Box | 5. Platform Aux. # 2 Connector (Spare) |
| 2. Junction Box Attach Screws | 6. Platform Aux. #1 (Footswitch/
Platform Gate Interlock Connector) |
| 3. Platform Console Harness Connector | 7. Programmable Security Lock (PSL)
Connector |
| 4. Ground Control Module Harness
Connector | |

Machines from SN 0130032507 to present have the following platform junction box connections (installation is same):

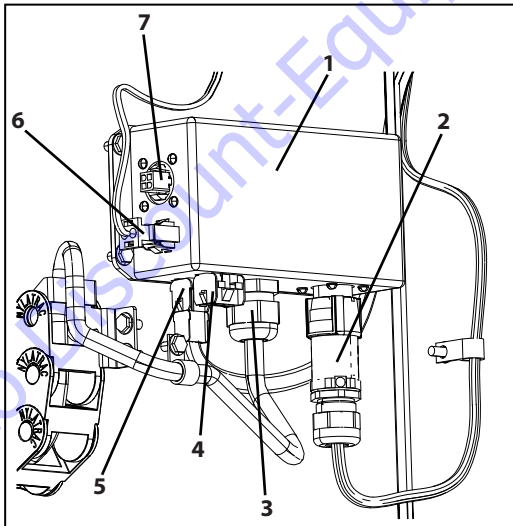

- | | |
|---|--|
| 1. Platform Junction Box | 4. Platform Aux #2 (Gate Interlock
Connector) |
| 2. Platform Console Harness Connector | 5. Power Tray Connector (Option) |
| 3. Ground Control Module Harness
Connector | 6. Platform Aux #1 (Left Hand Lift)
Connector |
| | 7. Footswitch Connector |

Junction Box to Ground Control Harness Installation

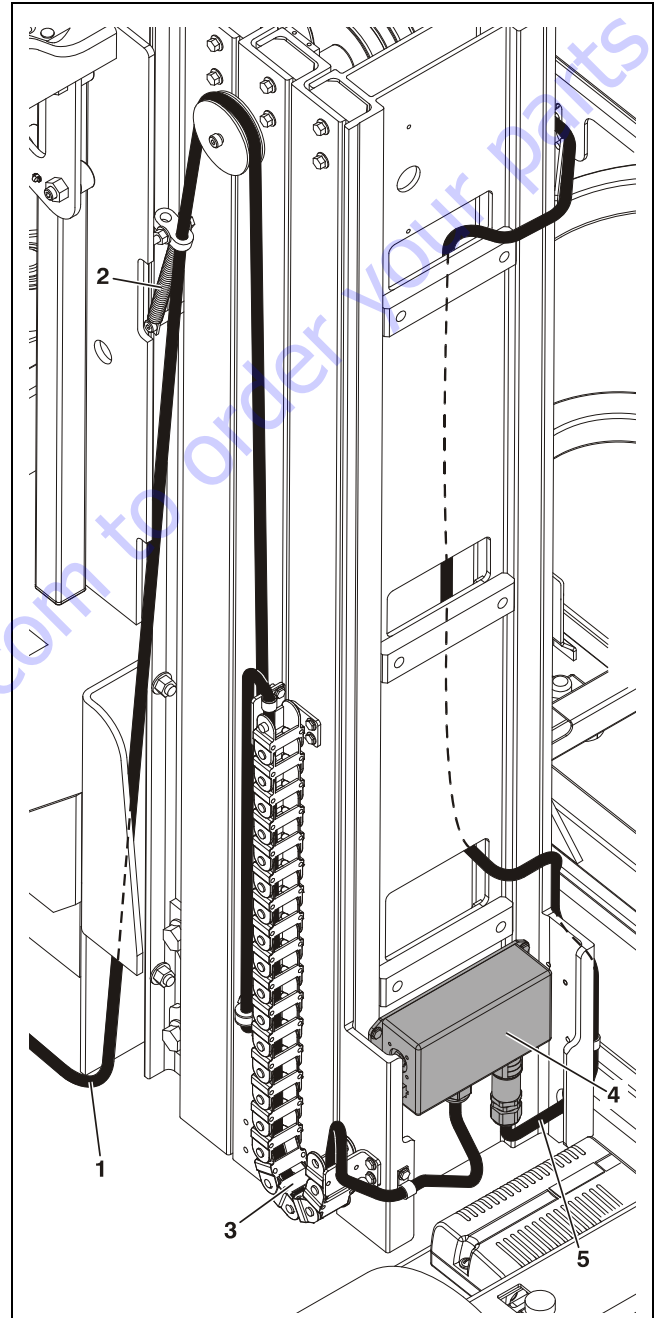

- | | |
|---|---|
| 1. Harness from Platform Junction Box
to Ground Control Module | 4. Platform Junction Box |
| 2. Spring Tensioner Clamp | 5. Platform Junction Box to Platform
Control Harness |
| 3. Power Track Assembly | |

Note: Refer to Section 5 for more detailed harness hardware installation.

Platform Interlock Switch Circuit

On machines prior to SN 0130032507, the platform interlock circuit consists of the platform footswitch and the platform gate switches wired in series. This circuit will inhibit the machines lift and drive functions and display a fault code on the Ground Control Station if the circuit is not closed during machine operation. The circuit utilizes the Auxiliary #1 plug on the Platform Junction Box (located under the platform). From there the circuit is wired to the Ground Control Module (P2) connector through the Platform Junction Box to Ground Control Module (P2) wiring harness. For Ground Control Module (P2) pin assignments see the electrical schematic in Section 6.

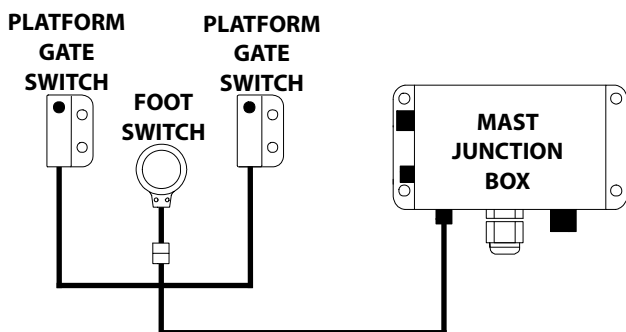

Figure 4-4. Platform Interlock Switch Circuit (Prior to SN 0130032507)

On machines from SN 0130032507 to present, the platform interlock circuit excludes the footswitch circuit.

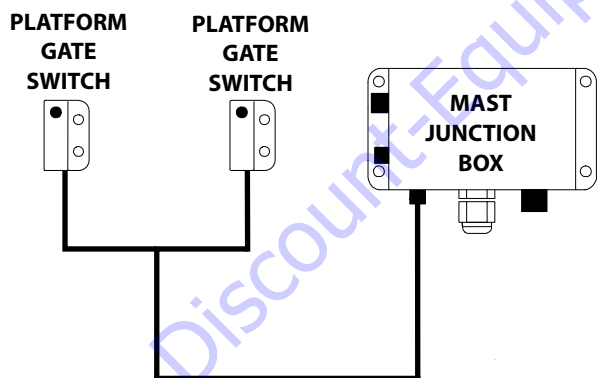

Figure 4-5. Platform Interlock Switch Circuit (SN 0130032507 to Present)

Component Electrical Connections

Note: Refer to Section 6 for complete machine wiring schematic.

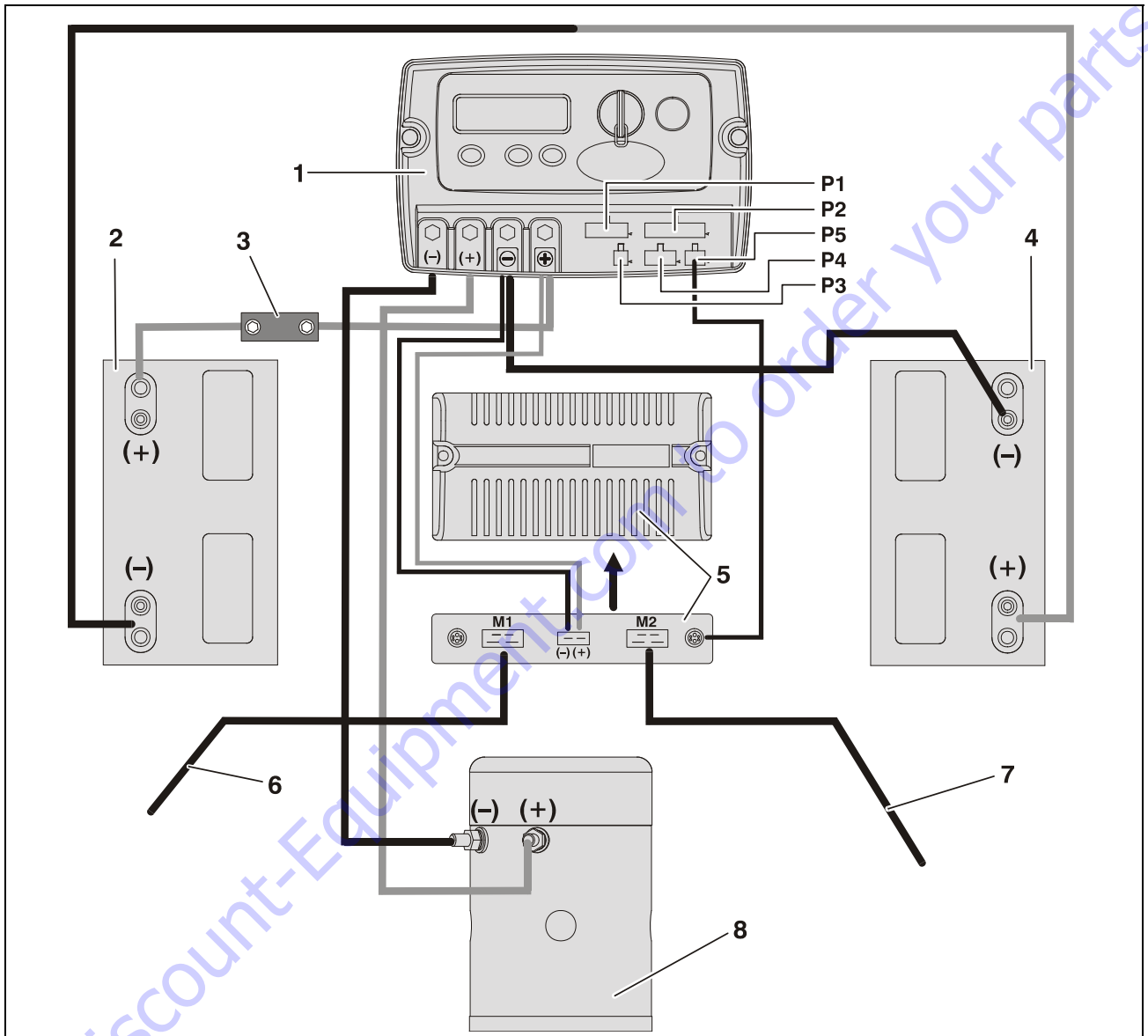

Figure 4-6. Component Electrical Connections (2-12V Batteries)

- | | | |
|------------------------------|--|---|
| 1. Ground Control Module (a) | 4. Right Side Battery (b) | 7. Power Cable To Right Drive Motor/Brake (a) |
| 2. Left Side Battery (b) (c) | 5. Traction Control Module (a) | 8. Hydraulic Pump/Motor/Tank Assembly (b) |
| 3. 175 Amp Fuse | 6. Power Cable To Left Drive Motor/Brake (a) | |

Ground Control Module Plugs:

- | | |
|--|---|
| P1 - Horn, Alarm, Beacons, Lift Down Valve Harness (a) | P4 - Platform Joystick Harness (a) |
| P2 - Elevation/Speed, Charger Limit Switch Harness (a) | P5 - Joystick Protocol Harness to Traction Control Module (a) |
| P3 - Programmable Security Lock Harness (Option) (a) | |

- Notes:**
- (a) Apply dielectric grease JLG P/N 3020038 to wiring harness terminals to prevent moisture from entering module.
 - (b) Seal NEG (-) and POS (+) posts with battery grease to prevent corrosion.
 - (c) An quick-disconnect is installed on left battery (+) POSITIVE cable for easy power disconnect when servicing.

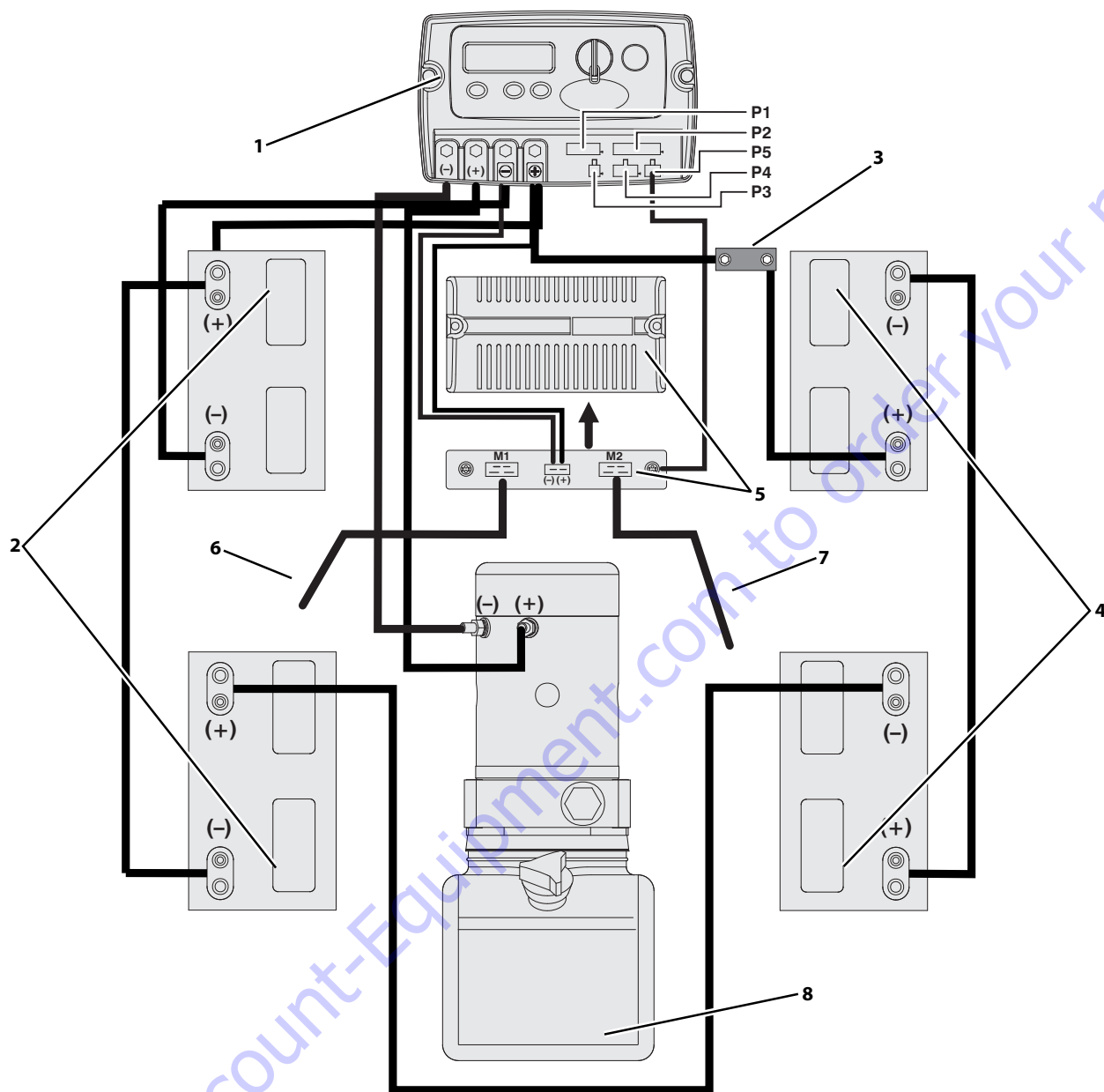

Figure 4-7. Component Electrical Connections (4-6V Batteries)

- 1. Ground Control Module (a)
- 2. Left Side Battery (b) (c)
- 3. 175 Amp Fuse
- 4. Right Side Battery (b)
- 5. Traction Control Module (a)
- 6. Power Cable To Left Drive Motor/Brake (a)
- 7. Power Cable To Right Drive Motor/Brake (a)
- 8. Hydraulic Pump/Motor/Tank Assembly (b)

Ground Control Module Plugs: **P1** - Horn, Alarm, Beacons, Lift Down Valve Harness (a)
P2 - Elevation/Speed, Charger Limit Switch Harness (a)
P3 - Programmable Security Lock Harness (Option) (a)

P4 - Platform Joystick Harness (a)
P5 - Joystick Protocol Harness to Traction Control Module (a)

Notes: (a) Apply dielectric grease JLG P/N 3020038 to wiring harness terminals to prevent moisture from entering module.
 (b) Seal NEG (-) and POS (+) posts with battery grease to prevent corrosion.
 (c) An quick-disconnect is installed on left battery (+) POSITIVE cable for easy power disconnect when servicing.

4.3 GROUND CONTROL MODULE

NOTICE

DO NOT ATTEMPT TO DISASSEMBLE THE GROUND CONTROL MODULE IF MACHINE IS STILL UNDER WARRANTY. OPENING THE GROUND CONTROL MODULE WHILE THE MACHINE IS UNDER WARRANTY WILL VOID THE WARRANTY. IF UNDER WARRANTY REQUEST A REPLACEMENT MODULE FROM THE FACTORY.

The Ground Control Module allows for field replacement of two components internal to the module.

- Emergency Stop Switch
- Power Selector Switch (Key)

NOTICE

ELECTROSTATIC DISCHARGE CAN DAMAGE COMPONENTS ON THE INTEGRATED CIRCUIT BOARD. PLACE THE GROUND CONTROL MODULE ON A NON-CONDUCTIVE SURFACE WHEN OPENING.

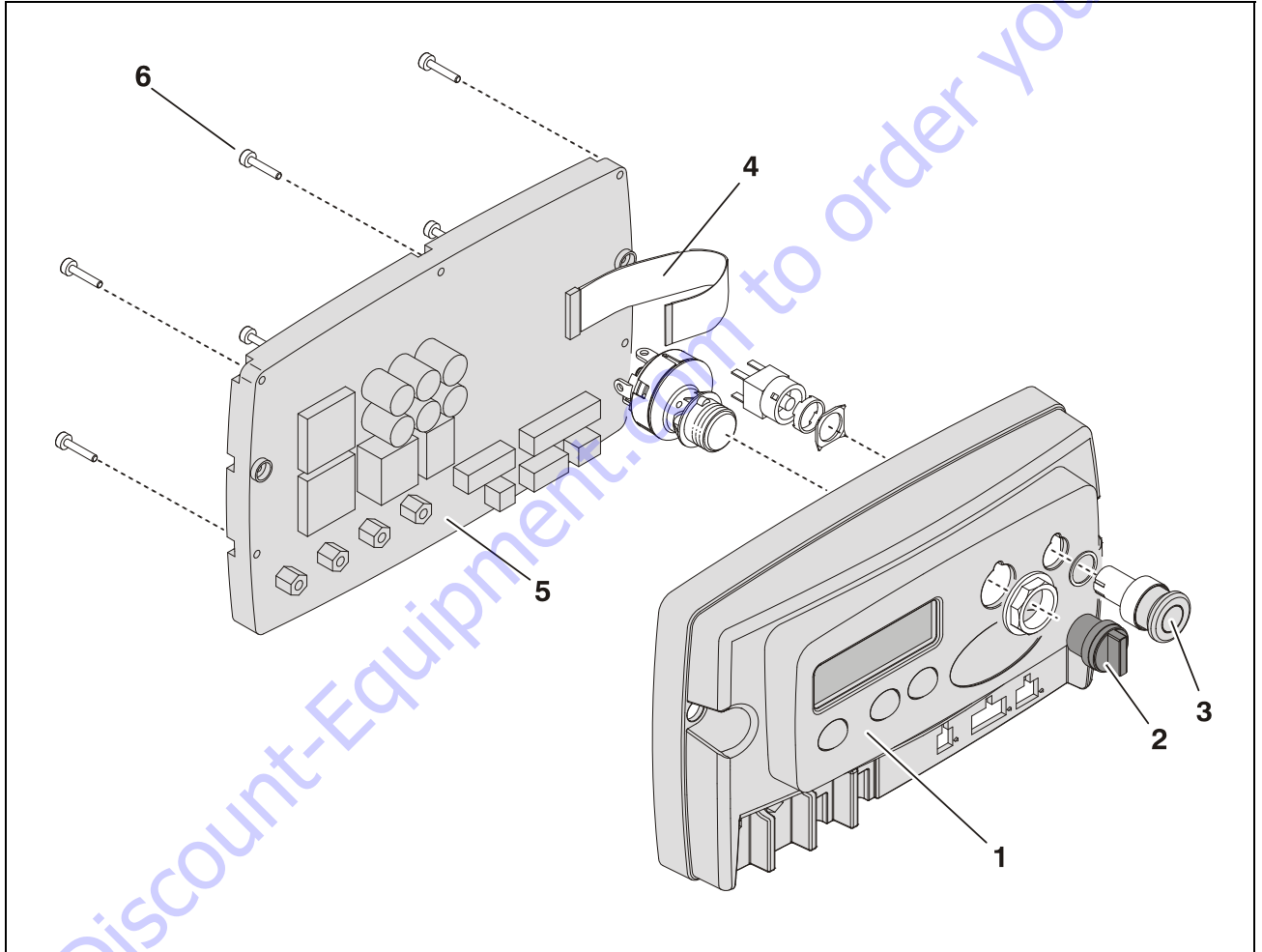

Figure 4-8. Ground Control Module Components

- | | |
|-----------------------------------|---------------------------------------|
| 1. Cover/LCD Assembly | 4. Main Board to LCD - Ribbon Cable |
| 2. Power Selector Switch Assembly | 5. Heat Sink Base/Main Board Assembly |
| 3. Emergency Stop Switch Assembly | 6. Cover Attach Screws |

Cover Removal/Installation

NOTICE

THE MAIN CIRCUIT BOARD AND THE SMALLER LCD CIRCUIT BOARD MOUNTED TO THE COVER ASSEMBLY ARE CONNECTED BY A RIBBON CABLE. REMOVE THE COVER CAREFULLY ONCE THE COVER SCREWS ARE REMOVED FROM THE BACK OF THE MODULE.

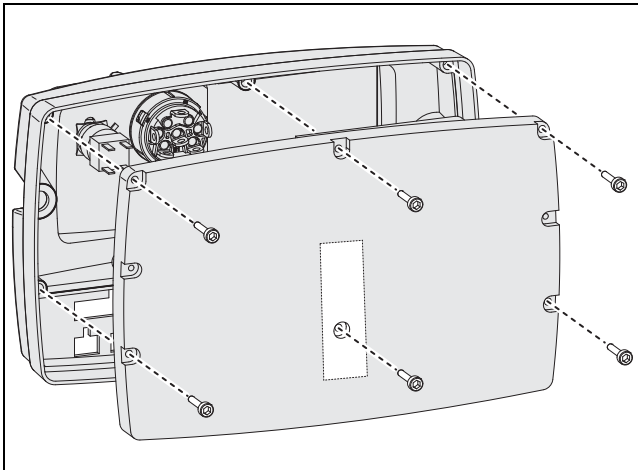

Cover Installation

Remove the six Hex Socket Screws from the Heat Sink/Base. One screw is under the Warranty/Tamper Label.

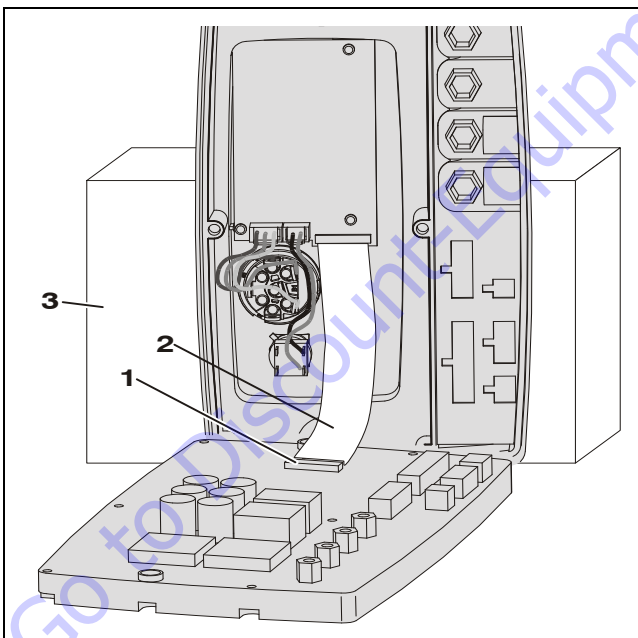

Disconnect the Ribbon Cable

- 1. Ribbon Cable Connector
- 2. Ribbon Cable
- 3. Support for Cover

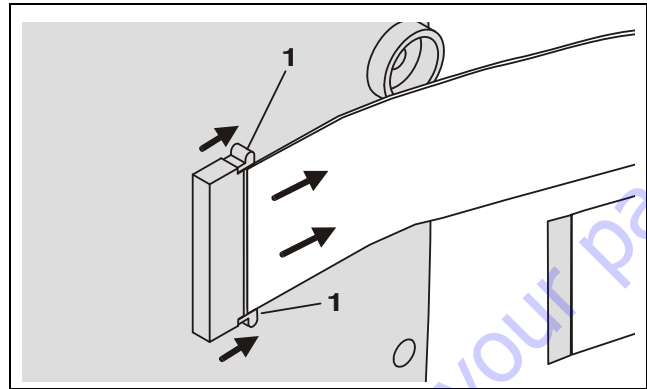

Release Ribbon Cable

- 1. Ribbon Cable Connector Tabs
(Push tabs away from connector to release cable then slide cable out of connector)

Note: Connector works the same at both ends of ribbon cable.

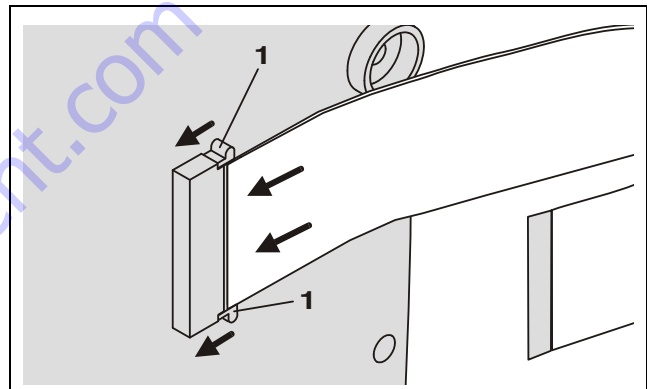

Reconnect Ribbon Cable

- 1. Ribbon Cable Connector Release Tabs
(Slide cable into connector then push tabs back into connector)

Note: Connector works the same at both ends of ribbon cable.

Power Selector/Emergency Stop Switch Installation

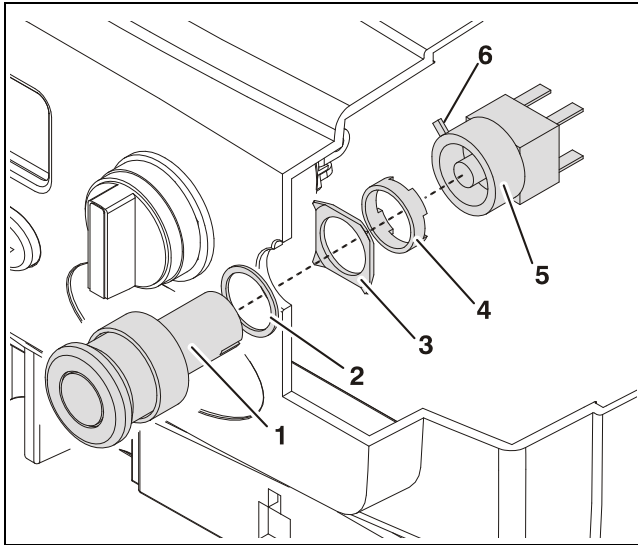

Emergency Stop Switch Installation

- | | |
|--------------------------|------------------------------|
| 1. Emergency Stop Button | 4. Nut |
| 2. Button Seal | 5. Emergency Stop Switch |
| 3. Square Lock Washer | 6. Switch Lock/Release Lever |

Note: Tighten nut enough to keep button from turning. Reattach wires to same terminals on new switch.

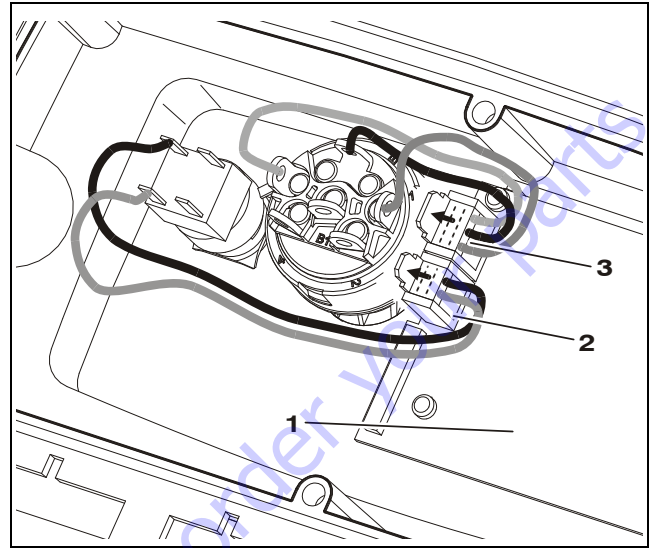

Emergency Stop/Power Selector Switch Connector Locations

- | |
|---|
| 1. LCD and Button Circuit Board |
| 2. Emergency Stop Switch Connector |
| 3. Main Power Selector Switch Connector |

Note: To release switch connectors, push tab on top of connector.

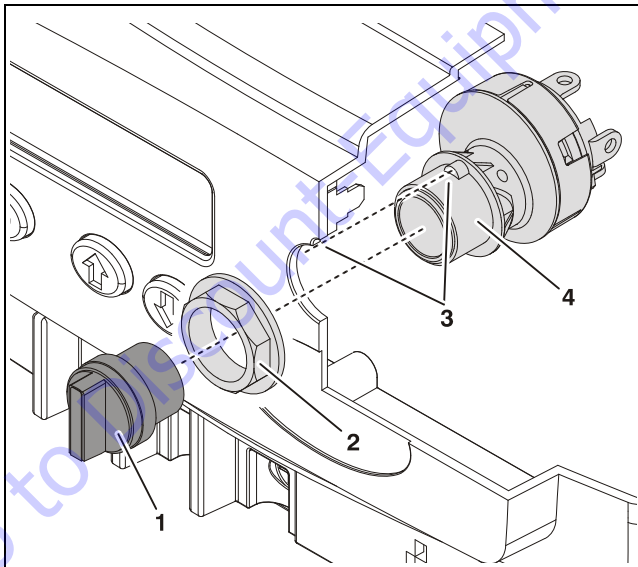

Power Selector Switch Installation

- | | |
|------------------|------------------------------------|
| 1. Selector Knob | 3. Power Selector Switch |
| 2. Nut | 4. Align and insert tab into cover |

Note: Reattach wires to the same terminals on new switch.

4.4 GROUND CONTROL MODULE PROGRAMMING

General

The Ground Control Module allows on-board programming of various component and control function personality settings.

Programming may be required under circumstances such as:

- Replacement of the Ground Control or Traction Control Module some components or optional equipment may not be enabled under the standard default settings of the replacement unit.
- Optional equipment has been added to the machine in the field and that function must be enabled before operation.
- Customizing the machine to fit a specific application, such as changing the LCD display language, programming operating speeds such as braking, turning or lifting speeds.

Programming Levels

There are three **password protected** programming levels. From highest to lowest, the levels are:

- **Level 1:** JLG Engineering Settings
- **Level 2:** Service and Maintenance Settings -
Level 2 Password: 91101
- **Level 3:** Operator Settings -
Level 3 Password: 33271

NOTICE

THE LEVEL 1: JLG ENGINEERING SETTINGS ARE NOT DISPLAYED IN THE PROGRAMMABLE SETTINGS UNDER PASSWORD LEVEL-2 OR LEVEL-3. LEVEL-1 SETTINGS MUST NOT BE MODIFIED UNLESS DIRECTED BY JLG ENGINEERING DEPARTMENT PERSONNEL.

Level 1: JLG Engineering Settings include voltage, amperage, and ohm output settings that are within the operating parameters of various machine components. This Level can adjust all programmable settings.

Level 2: Service and Maintenance Settings allow modification to machine personality settings such as lift speeds, drive speeds, as well as various switch polarity settings, also enable various optional equipment if installed. This level can also adjust Level-3 settings.

Level 3: Operator Settings allow the direct user to modify a few settings such as the language setting of text output to the Ground Control Module LCD screen, setting machine sleep time, and enabling the detection of the horn and beacon components.

Activating Programming Mode

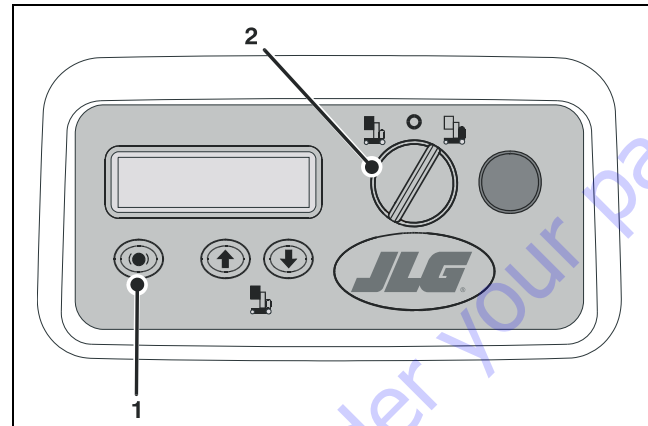

1. With machine power off, press and hold the Brake Release Button (1) on the Ground Control Module.
2. Power machine up by turning the Main Power Selector Switch (2), to either the Ground Control or Platform Control Mode.
3. Release the Brake Release Button (1) after machine is powered up. LCD display should now display five zeros, one with a box around. Continue to next step.

Note: If machine does not power up, ensure the Emergency Stop Buttons at the Ground Controls and on the Platform Control Console are in the RESET position. If machine is equipped with the Programmable Security Lock (PSL) option, refer to the Operators Manual for additional machine power-up steps.

Entering Password

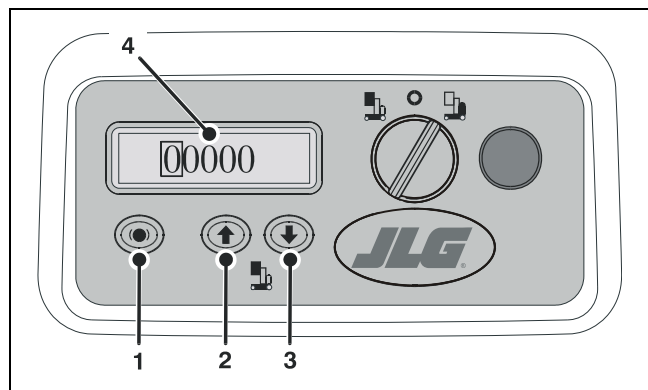

1. The Brake Release button (1) moves the box (around digit) from left to right to select which digit to change.
2. Platform UP button (2) increases the numerical digit.
3. Platform DOWN button (3) decreases the numerical digit.
4. Change all five digits (4) to match password level, then press the Brake Release button (1) again.

Programming Mode Selection

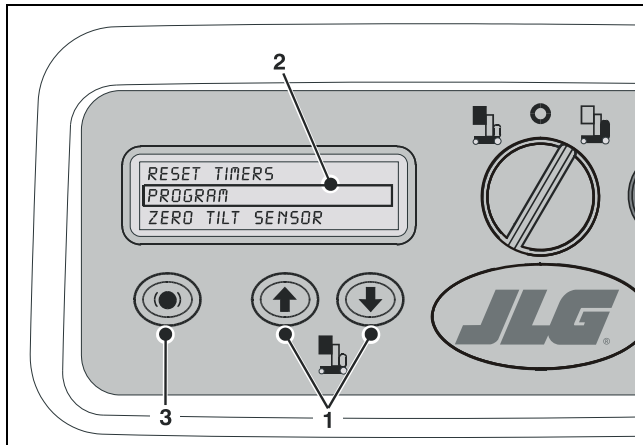

1. Use Platform UP/DOWN buttons (1) to move the selection box (2) up or down to select item to program.
2. Press the Brake Release button (3) to enter selected mode then move on to Selecting Programmable Item to Adjust.

Adjusting Programmable Setting

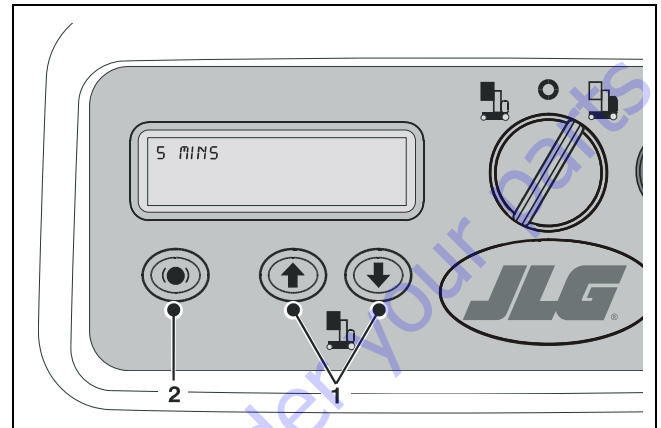

1. Adjust the programmable setting using the Platform UP/DOWN buttons (1), see Table 4-1 for range of settings for the item selected.
2. Once parameter is set for the programmable item, press the Brake Release button (2), this will enter the parameter and return you to the Programmable Settings Menu.

Selecting Programmable Item to Adjust

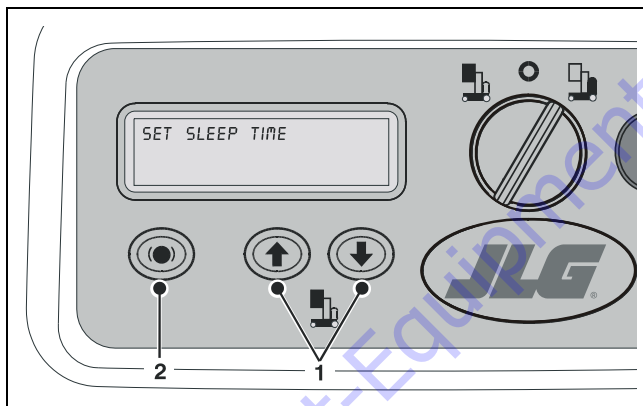

1. Use the Platform UP/DOWN buttons (1) to scroll through the list of programmable items available to your programming level.
2. Once a programmable item to be adjusted is selected, press the Brake Release button (2) to enter that settings' adjustment mode.

TO EXIT Programming Mode after entering programmable settings, power machine off with either the Main Power Selector Switch or Emergency Stop Button.

Service Programming Mode - Level 2

In the Service Programming Mode the following items are shown on the main menu (also refer to Table 4-1):

- Reset Timers
- Program
- Tilt Sensor
- OSS Sensor

Note: There are two production modules available at this time, one for North/South American and European languages, and one for Asian languages. All programmable items between these modules are identical with the exception of language selection.

Reset Timers

This setting displays five timers as described following:

- **Trip Time:** This timer shows total accumulated hours since last trip timer reset. This is the hour meter reading displayed on the Ground Control Module LCD Display during normal machine operation.
- **Traction Time:** Displays the amount of accumulated DRIVE hours on the machine's current drive components.
- **Lift UP Time:** Displays the amount of accumulated time the machine has operated the Lift UP function.
- **Lift DOWN Time:** Displays the amount of accumulated time machine has operated the Lift DOWN function.
- **Total Time:** Displays the total amount of time accumulated by the Traction, Lift UP and Lift DOWN Timers.

Of these five timers, the Trip Timer is the only timer which can be RESET back to 00000.0.

- **Brush Wear Sensor Timer:** This timer must be reset after the drive motor brushes are replaced and the brush wear sensors are repositioned. When reset the display will go from WORN to a blank display. Also the 25 hr/10 second countdown will stop and normal machine operation will resume.

Program

Allows service personnel to program the Level 2 and Level 3 items shown in Table 4-1.

Tilt Sensor

Allows service personnel to reset the Ground Control Module's internal digital Tilt Sensor to zero (0.0) degrees in both the X and Y axis.

DANGER

ZEROING THE TILT SENSOR REQUIRES THE MACHINE TO BE RESTING ON A SURFACE CHECKED WITH A DIGITAL LEVEL MEASURING WITHIN 0.0 DEGREES LEVEL IN BOTH THE X AND Y AXIS DIRECTIONS.

Note: When entering this mode the LCD will display in real time the current X and Y degree readings of the tilt sensor. The reading being displayed is based on the previous zero setting and may not reflect level of the machines current resting surface.

1. Position the machine on a level surface verified level in both the X and Y axis with a digital level.
2. Select "Zero Tilt Sensor" from the menu and press the Brake Release button.
3. The current tilt sensor readings are displayed. To zero both the X and Y direction sensor setting to the machines' present resting surface, press the Brake Release button.
4. Select "Back to Main Menu" and press the Brake Release Button.
5. Power machine off and begin operation.

Operator Programming Mode - Level 3

In the Operator Programming Mode the following items are shown on the main menu (also refer to Table 4-1):

- Tilt Sensor
- Program

Note: There are two production modules available, one for North/South American and European languages, and one for Asian languages. All programmable items between these modules are identical with the exception of language selection.

Tilt Sensor

Allows viewing current tilt sensor individual X and Y direction degree reading.

Program

Allows the Operator to program Level 3 items shown in Table 4-1.

Table 4-1. Field Programmable Settings and Factory Preset (Prior to SN 0130032507)

Level 2: Service Level Settings		On LCD Display: YES = ✓ HIGH = ↑	
Level 3: Operator Level Settings		NO = ✗ LOW = ↓	
LEVEL	PROGRAMMABLE ITEM	FACTORY PRESET	SETTING RANGE
2	Back to Main	—	Return to Programming Menu
3	Set Language <i>Note: There are two production modules available at this time, one for North/South American and European Languages, and one for Asian Languages.</i>	1	1 - English 6 - Italian 2 - German 7 - Swedish 3 - Dutch 8 - Brazilian Portuguese 4 - French 9 - Finnish 5 - Spanish
		2	1 - English 3 - Japanese 2 - Chinese
2	Set Maximum Lift Up Speed	100%	0 - 100%
2	Set Maximum Lift Down Speed	100%	0 - 100%
2	Zero the On-Board Tilt Sensor	NO	YES/NO
2,3	Set Sleep Time	10 MINS	0 - 60 MINS
2	Set Polarity Of Left Pot Hole Input 1	0	0=DISABLED / 1=LOW / 2=HIGH
2	Set Polarity Of Right Pot Hole Input 2	0	0=DISABLED / 1=LOW / 2=HIGH
2	Set Polarity Of Up Limit/Elevation Input	HIGH	HIGH/LOW
2	Set Polarity Of Charger Inhibit	LOW	HIGH/LOW
2,3	Set Polarity Of The Keypad Code	LOW	HIGH/LOW
2	Set Polarity Of Ancillary Input 1	HIGH	HIGH/LOW
2	Set Polarity Of Ancillary Input 2	LOW	HIGH/LOW
2,3	Enable Detection Of Horn Open Circuit	NO	YES/NO
2,3	Enable Detection Of Beacon Open Circuit	NO	YES/NO
2	Enable Obstruction Sensor System (OSS)	NO	YES/NO
2	Enable Detection Of Ancl. #1 Open Circuit	NO	YES/NO
2	Enable Detection Of Ancl #2 Open Circuit	NO	YES/NO
3	Forward Alarm Disable	NO	YES/NO
2	Brush Wear Sensor Timer Reset	—	BLANK/WORN
3	OSS Diagnostic	NO	YES/NO
2	Load Sensing (LSS)	OFF	OFF/CUTOUT PLAT./CUTOUT ALL
2	Aux. 1 - Inhibit - (Active when Ancillary 1 is set to HIGH)	4	0=Inhibit Lift 1=Inhibit Drive when Platform is elevated 2=Inhibit Drive regardless of Plat. position 3=Inhibit Lift and Drive when Plat. elevated 4=Inhibit Lift and Drive regardless of Plat. position
2	Aux. 2 - Inhibit - (Active when Ancillary 2 is set to HIGH)	0	0=Inhibit Lift 1=Inhibit Drive when Platform is elevated 2=Inhibit Drive regardless of Plat. position 3=Inhibit Lift and Drive when Plat. elevated 4=Inhibit Lift and Drive regardless of Plat. position
2	Aux. 1 - Tie Down	1	0=Disabled 1=trip if low at start-up 2=trip high at start-up
2	Aux. 2 - Tie Down	0	0=Disabled 1=trip if low at start-up 2=trip high at start-up
2	Mode Select Delay (Active before timeout)	5 SEC.	1 - 60 SECONDS
2	Acceleration (Platform Lowered)	80	1 - 100

SECTION 4 - CONTROL COMPONENTS

Table 4-1. Field Programmable Settings and Factory Preset (Prior to SN 0130032507)

Level 2: Service Level Settings		On LCD Display: YES = <input checked="" type="checkbox"/> HIGH = <input type="checkbox"/>	
Level 3: Operator Level Settings		NO = <input checked="" type="checkbox"/> LOW = <input type="checkbox"/>	
LEVEL	PROGRAMMABLE ITEM	FACTORY PRESET	SETTING RANGE
2	Deceleration (Platform Lowered)	90	1 - 100
2	Turn Acceleration (Platform Lowered)	80	1 - 100
2	Turn Deceleration (Platform Lowered)	100	1 - 100
2	Maximum Forward Speed (Platform Lowered)	100	1 - 100
2	Minimum Forward Speed (Platform Lowered)	40	1 - 100
2	Maximum Reverse Speed (Platform Lowered)	50	1 - 100
2	Minimum Reverse Speed (Platform Lowered)	20	1 - 100
2	Maximum Turn Speed (Platform Lowered)	30	1 - 100
2	Minimum Turn Speed (Platform Lowered)	15	1 - 100
2	Minimum Forward Speed (Platform Elevated)	13	1 - 100
2	Minimum Reverse Speed (Platform Elevated)	9	1 - 100
2	Minimum Turn Speed (Platform Elevated)	5	1 - 100
2	Motor Compensation	50 mOhms	0 - 500 mOhms

Table 4-2. Field Programmable Settings and Factory Preset (SN 0130032507 to Present)

Level 2: Service Level Settings		On LCD Display: YES = ✓ HIGH = ↑	
Level 3: Operator Level Settings		NO = ✗ LOW = ↓	
LEVEL	PROGRAMMABLE ITEM	FACTORY PRESET	SETTING RANGE
2	Back to Main	—	Return to Programming Menu
3	Set Language <i>Note: There are two production modules available at this time, one for North/South American and European Languages, and one for Asian Languages.</i>	1	1 - English 6 - Italian 2 - German 7 - Swedish 3 - Dutch 8 - Finnish 4 - French 5 - Spanish
		2	1 - English 3 - Japanese 2 - Chinese
2	Set Maximum Lift Up Speed	100%	0 - 100%
2	Set Maximum Lift Down Speed	100%	0 - 100%
2	Zero the On-Board Tilt Sensor	NO	YES/NO
3	Set Sleep Time	10 MINS	0 - 60 MINS
2	Set Polarity Of Left Pot Hole Input 1	1	0=DISABLED / 1=LOW / 2=HIGH
2	Set Polarity Of Right Pot Hole Input 2	0	0=DISABLED / 1=LOW / 2=HIGH
2	Set Polarity Of Up Limit/Elevation Input	HIGH	HIGH/LOW
2	Set Polarity Of Charger Inhibit	LOW	HIGH/LOW
3	Set Polarity Of The Keypad Code	LOW	HIGH/LOW
2	Set Polarity Of Ancillary Input 1	LOW	HIGH/LOW
2	Set Polarity Of Ancillary Input 2	HIGH	HIGH/LOW
2	Load Sensing (LSS)	0	OFF/CUTOUT PLAT./CUTOUT ALL
3	Enable Detection Of Horn Open Circuit	NO	YES/NO
3	Enable Detection Of Beacon Open Circuit	NO	YES/NO
2	Enable Obstruction Sensor System (OSS)	NO	YES/NO
2	Enable Detection Of Ancl. #1 Open Circuit	NO	YES/NO
2	Enable Detection Of Ancl #2 Open Circuit	NO	YES/NO
3	Forward Alarm Disable	NO	YES/NO
2	Brush Wear Sensor Timer Reset	—	BLANK/WORN
3	OSS Diagnostic	NO	YES/NO
2	Load Sensing (LSS)	OFF	OFF/CUTOUT PLAT./CUTOUT ALL
2	Aux. 1 - Inhibit - (Active when Ancillary 1 is set to HIGH)	4	0=Inhibit Lift 1=Inhibit Drive when Platform is elevated 2=Inhibit Drive regardless of Plat. position 3=Inhibit Lift and Drive when Plat. elevated 4=Inhibit Lift and Drive regardless of Plat. position
2	Aux. 2 - Inhibit - (Active when Ancillary 2 is set to HIGH)	5	0=Inhibit Lift 1=Inhibit Drive when Platform is elevated 2=Inhibit Drive regardless of Plat. position 3=Inhibit Lift and Drive when Plat. elevated 4=Inhibit Lift and Drive regardless of Plat. position
2	Aux. 1 - Tie Down	4	0=Disabled 1=trip if low at start-up 2=trip high at start-up
2	Aux. 2 - Tie Down	2	0=Disabled 1=trip if low at start-up 2=trip high at start-up
2	Mode Select Delay (Active before timeout)	5 SEC	1 - 60 SECONDS

SECTION 4 - CONTROL COMPONENTS

Table 4-2. Field Programmable Settings and Factory Preset (SN 0130032507 to Present)

Level 2: Service Level Settings		On LCD Display: YES = <input checked="" type="checkbox"/> HIGH = \uparrow	
Level 3: Operator Level Settings		NO = <input checked="" type="checkbox"/> LOW = \downarrow	
LEVEL	PROGRAMMABLE ITEM	FACTORY PRESET	SETTING RANGE
2	Acceleration (Platform Lowered)	50	1 - 100
2	Deceleration (Platform Lowered)	30	1 - 100
2	Turn Acceleration (Platform Lowered)	80	1 - 100
2	Turn Deceleration (Platform Lowered)	80	1 - 100
2	Maximum Forward Speed (Platform Lowered)	100	1 - 100
2	Minimum Forward Speed (Platform Lowered)	10	1 - 100
2	Maximum Reverse Speed (Platform Lowered)	40	1 - 100
2	Minimum Reverse Speed (Platform Lowered)	10	1 - 100
2	Maximum Turn Speed (Platform Lowered)	40	1 - 100
2	Minimum Turn Speed (Platform Lowered)	10	1 - 100
2	Minimum Forward Speed (Platform Elevated)	10	1 - 100
2	Minimum Reverse Speed (Platform Elevated)	5	1 - 100
2	Minimum Turn Speed (Platform Elevated)	5	1 - 100
2	Motor Compensation	25mOhms	0 - 500 mOhms

4.5 PLATFORM CONTROL CONSOLE

General

NOTICE

DO NOT ATTEMPT TO DISASSEMBLE THE PLATFORM CONTROL BOX IF MACHINE IS STILL UNDER WARRANTY. OPENING THE PLATFORM CONTROL BOX WHILE THE MACHINE IS UNDER WARRANTY WILL VOID THE WARRANTY. IF UNDER WARRANTY REQUEST A REPLACEMENT BOX FROM THE FACTORY.

The platform control console allows for replacement of nine components. For key, refer to Figure 4-9.

- Emergency Stop Switch (1)
- Key Switch(2)
- Joystick Assembly (3)
- Display/Controller Module (4)
- Drive/Lift Mode Selector Switch (prior to SN 0130032507) (5)
- Horn Button Switch (6)
- Rear Cover (7)
- Wiring Harness Connector Socket (8)
- Mounting Bracket (9)

Before servicing the Platform Control Console, remove it completely from the platform assembly (refer to Section 4.2).

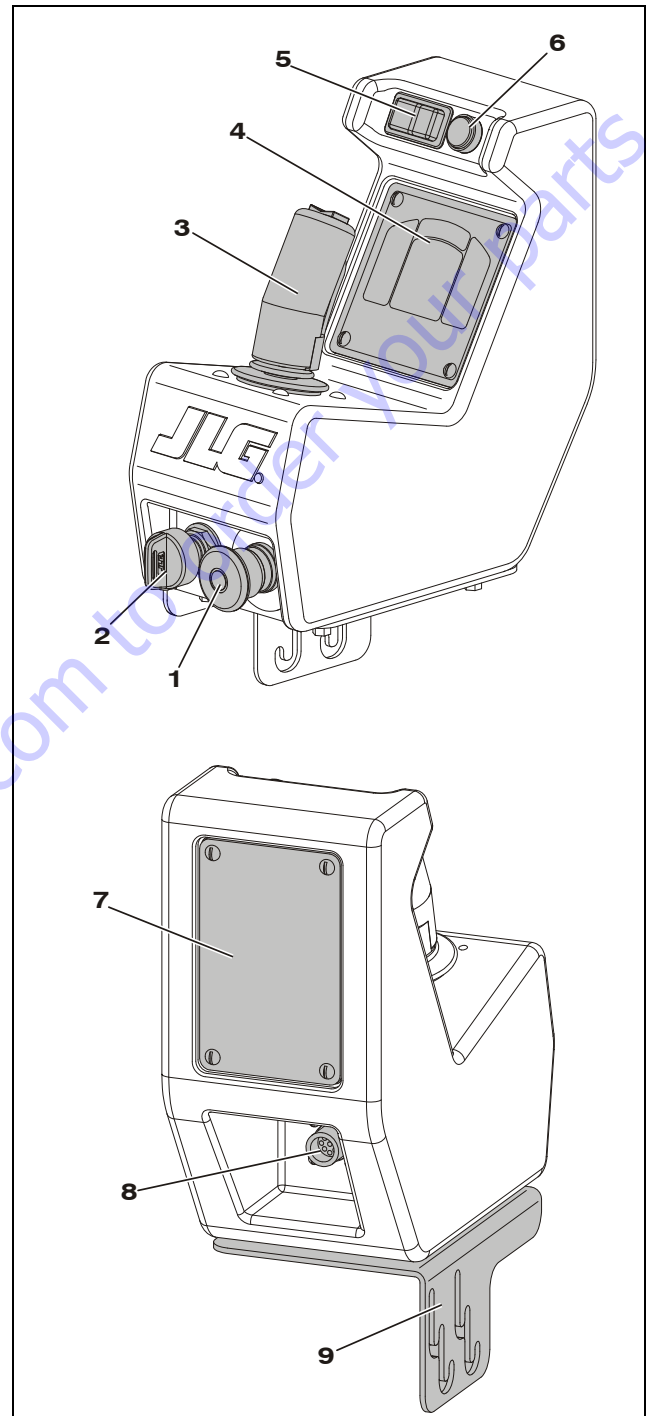
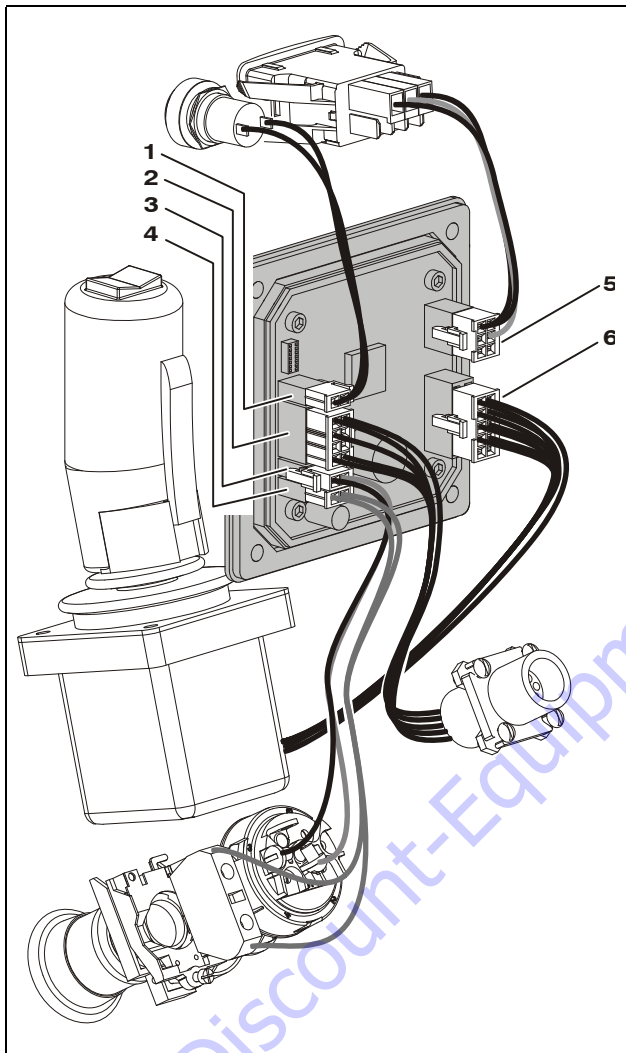

Figure 4-9. Platform Control Console Installation

Display/Controller Module Electrical Connections

The internal switches and joystick controller of the platform console plug directly into the Display/Controller Module. This module then relays the signals from these switches to the Ground Control Box through the communications cable running to the platform junction box mounted to the mast under the platform.



- | | |
|---|--------------------------------------|
| 1. Horn Switch (C5) | 4. E-Stop/ShutDown Switch (C4) |
| 2. Communications Cable to Platform Junction Box (C6) | 5. Drive/Lift ModeSelect Switch (C7) |
| 3. ON/OFF Key Switch (C3) | 6. Joystick - (C8) |

Note: The (C) numbers shown after the description above represent the corresponding identification of the plug on the module's circuit board.

Mounting Bracket

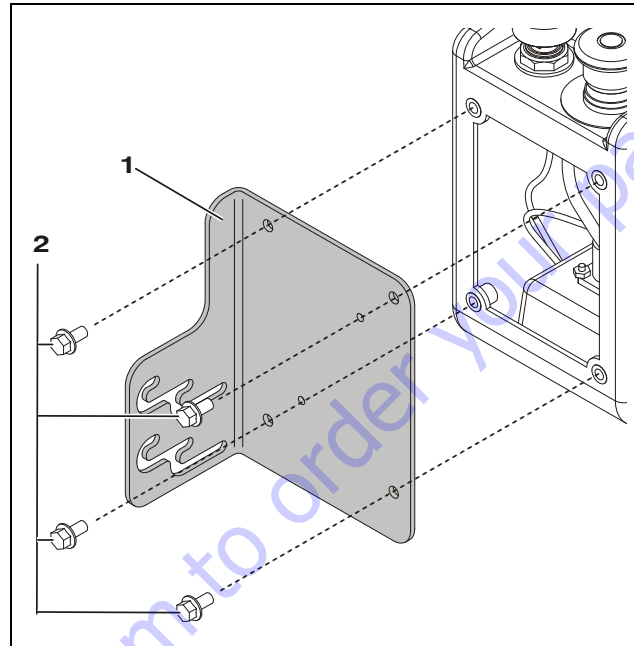

- | | |
|---------------------|-----------------------|
| 1. Mounting Bracket | 2. Bracket Screws (a) |
|---------------------|-----------------------|

Note: (a) Apply Loctite #242 to screw threads on final assembly.

Rear Cover

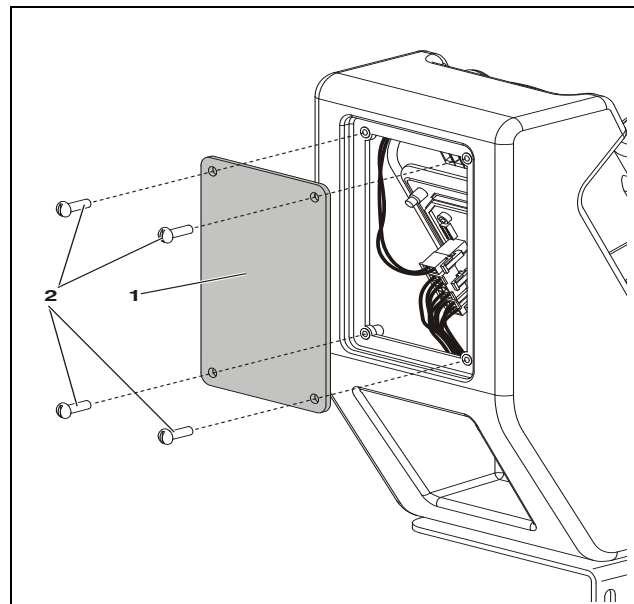

- | | |
|---------------|--------------------------|
| 1. Rear Cover | 2. Cover Mounting Screws |
|---------------|--------------------------|

Display/Controller Module

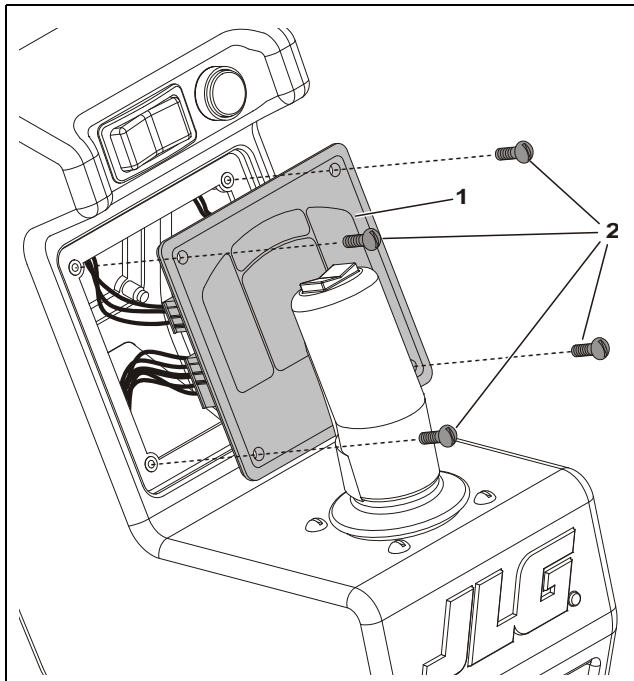

1. Display/Controller Module (a) 2. Mounting Screws

Note: (a) Unplug all connections on the back of the module before removing from console.

Horn Button Switch

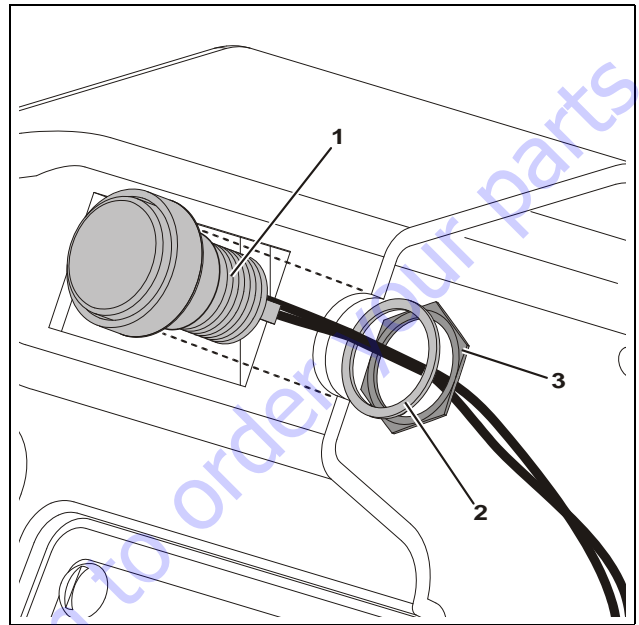

1. Horn Button Switch (a) 3. Nut
2. Lock Washer

Note: (a) Remove rear cover, unplug wire, remove nut and lock washer, then slide switch out of console.

Drive/Lift Mode Switch (Prior to SN 0130032507)

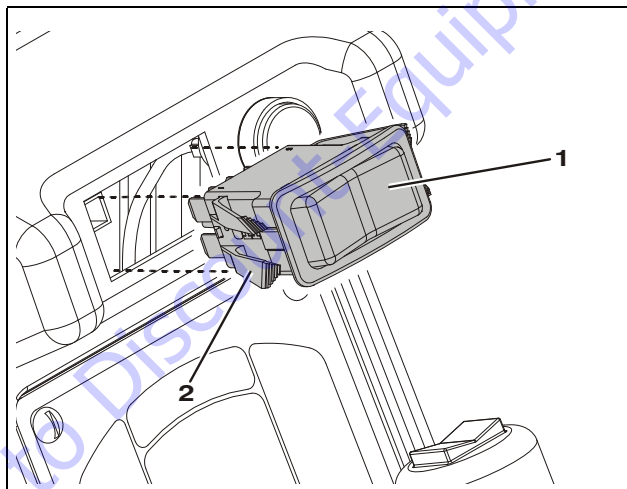

1. Switch Assembly (a) 2. Locking Tabs

Note: (a) Remove rear cover, unplug switch wire, press tabs to remove.

Key Switch

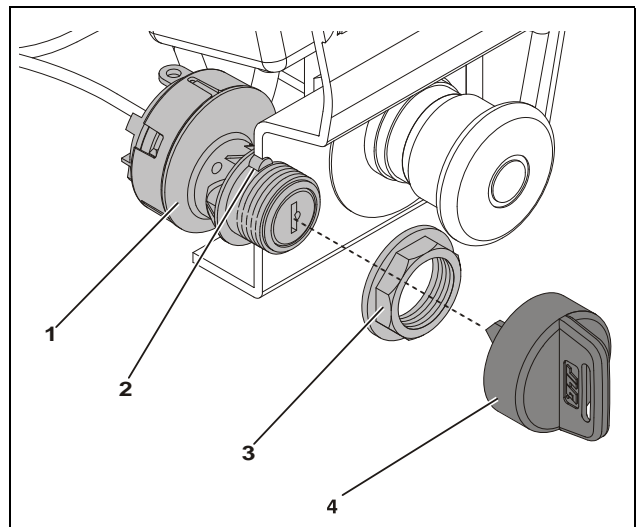

1. Key Switch (a) 3. Attach Nut
2. Notch 4. Key

Note: (a) Remove mounting bracket on bottom of console to gain access to the key switch assembly.

E-Stop/ShutDown Switch

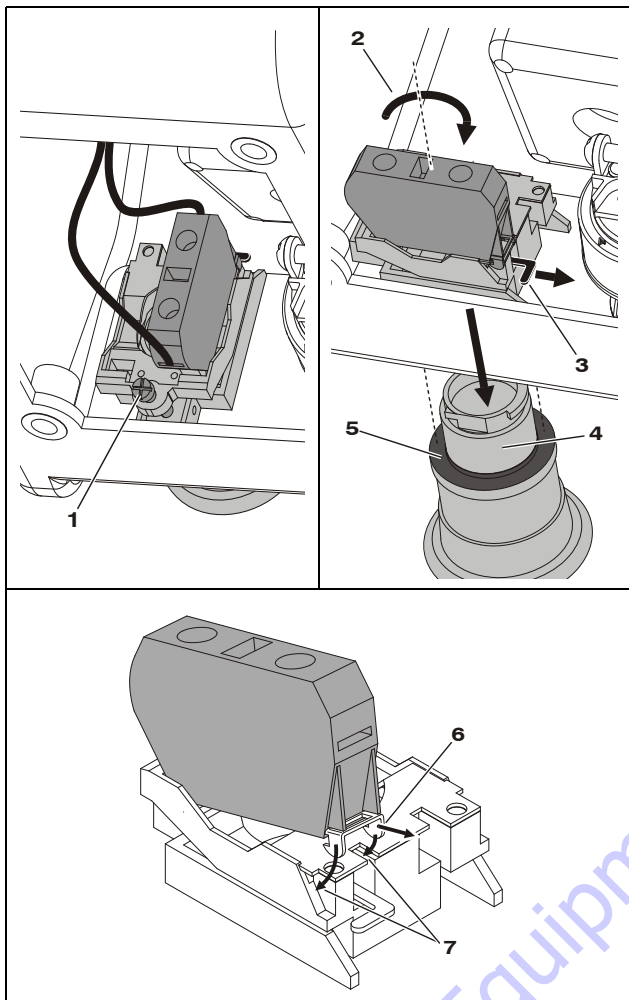

- | | |
|---|--------------------------------------|
| 1. Loosen Switch Set Screw | 5. Barrel Seal |
| 2. Turn Switch 90° | 6. Switch to Body Retainer Hooks (a) |
| 3. Pull Spring-Loaded Release Lever Out | 7. Switch Retainer Slots |
| 4. Remove Barrel Assembly | |

Note: (a) Use a small straight blade screwdriver to extend the spring-loaded retainer hooks (6) out and release the switch from the body.

Joystick Assembly

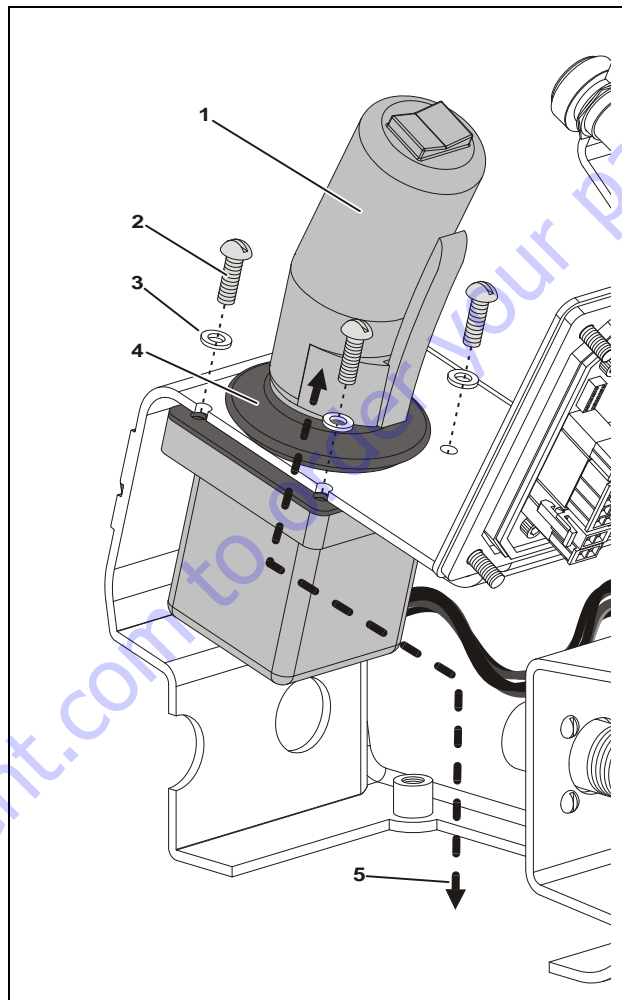

- | | |
|---------------------------|---|
| 1. Joystick Assembly | 4. Rubber Boot/Gasket |
| 2. Attach Screws (Qty.-4) | 5. Install/Remove through the Access Hole in Bottom of Housing. (a) (b) |
| 3. Nylon Washers (Qty.-4) | |

Note: (a) Remove the console mounting bracket.
 (b) Remove the key switch and e-stop switch to remove joystick assembly through access hole in bottom of console.

4.6 OBJECT DETECTION SYSTEM (IF EQUIPPED)

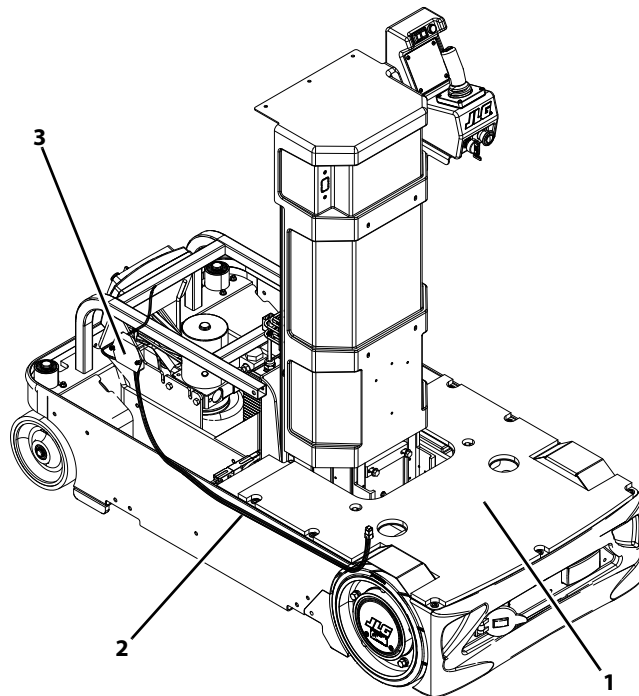

1. Object Sensing Pad
2. Object Detection System Harness
3. Relay

Figure 4-10. Object Detection System

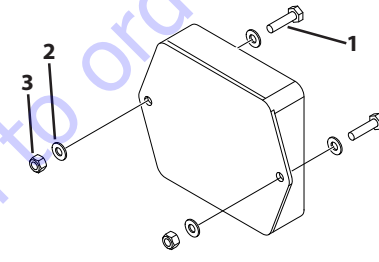
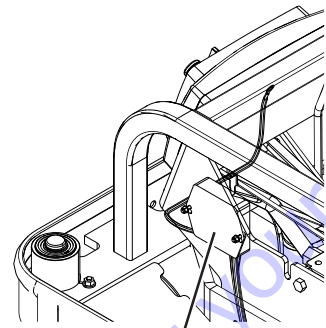

1. Bolt (2, M4X16)
2. Washer (4)
3. Nut (4)

Figure 4-10. Relay Installation

Removal

If the Object Detection System is not functioning properly, replacing the object sensing pad may be required.

1. Raise and properly support the platform.
2. Disconnect the object sensing pad harness connection.
3. Peel and remove the object sensing pad from the base.
4. Clean any glue residue from the base.

Installation

1. Verify the base is clean. Apply adhesive (JLG PN 0100040) evenly over the base.

Note: Do not bend or manipulate the sensing pad. Doing so could damage the internal wiring.

2. Carefully remove the protective backing from the sensing pad and install on the base. Apply pressure on the sensing pad to ensure contact with the adhesive.
3. Connect the sensing pad harness connector.
4. Adjust the platform stops 1.375 in from frame.
5. Remove platform support.
6. Enable the Object Detection System at the Ground Control Module:
 - a. Enter programming mode (refer to section 3 for ground control programming).
 - b. Set "OSS Enable" to "2."
7. Test the Object Detection System per the function check instructions given in the operation manual.

PARTS FINDER

**Search Website
by Part Number**



**Search Manual
Library For Parts
Manual & Lookup Part
Numbers – Purchase
or Request Quote**

Search Manuals

Enter the model number of the equipment you are looking for to search for parts.

* Brand:

* Model:

* Serial:

SEARCH

**Can't Find Part or
Manual? Request Help
by Manufacturer,
Model & Description**

Parts Order Form

Please fill in the information below to request help finding a part.

Manufacturer:

Model:

Description:

Quantity:

Part Number:

Part Name:

Part Location:

Part Drawing:

Part Photo:

Part Diagram:

Part Notes:

Submit

Discount-Equipment.com is your online resource for quality parts & equipment.

Florida: **561-964-4949** Outside Florida TOLL FREE: **877-690-3101**

Need parts?

Click on this link: <http://www.discount-equipment.com/category/5443-parts/> and choose one of the options to help get the right parts and equipment you are looking for. Please have the machine model and serial number available in order to help us get you the correct parts. If you don't find the part on the website or on one of the online manuals, please fill out the request form and one of our experienced staff members will get back to you with a quote for the right part that your machine needs.

We sell worldwide for the brands: Genie, Terex, JLG, MultiQuip, Mikasa, Essick, Whiteman, Mayco, Toro Stone, Diamond Products, Generac Magnum, Airman, Haulotte, Barreto, Power Blanket, Nifty Lift, Atlas Copco, Chicago Pneumatic, Allmand, Miller Curber, Skyjack, Lull, Skytrak, Tsurumi, Husquvarna Target, , Stow, Wacker, Sakai, Mi-T- M, Sullair, Basic, Dynapac, MBW, Weber, Bartell, Bennar Newman, Haulotte, Ditch Runner, Menegotti, Morrison, Contec, Buddy, Crown, Edco, Wyco, Bomag, Laymor, Barreto, EZ Trench, Bil-Jax, F.S. Curtis, Gehl Pavers, Heli, Honda, ICS/PowerGrit, IHI, Partner, Imer, Clipper, MMD, Koshin, Rice, CH&E, General Equipment, ,AMida, Coleman, NAC, Gradall, Square Shooter, Kent, Stanley, Tamco, Toku, Hatz, Kohler, Robin, Wisconsin, Northrock, Oztec, Toker TK, Rol-Air, Small Line, Wanco, Yanmar

SECTION 5. MAST COMPONENTS

5.1 MAST COMPONENTS OVERVIEW

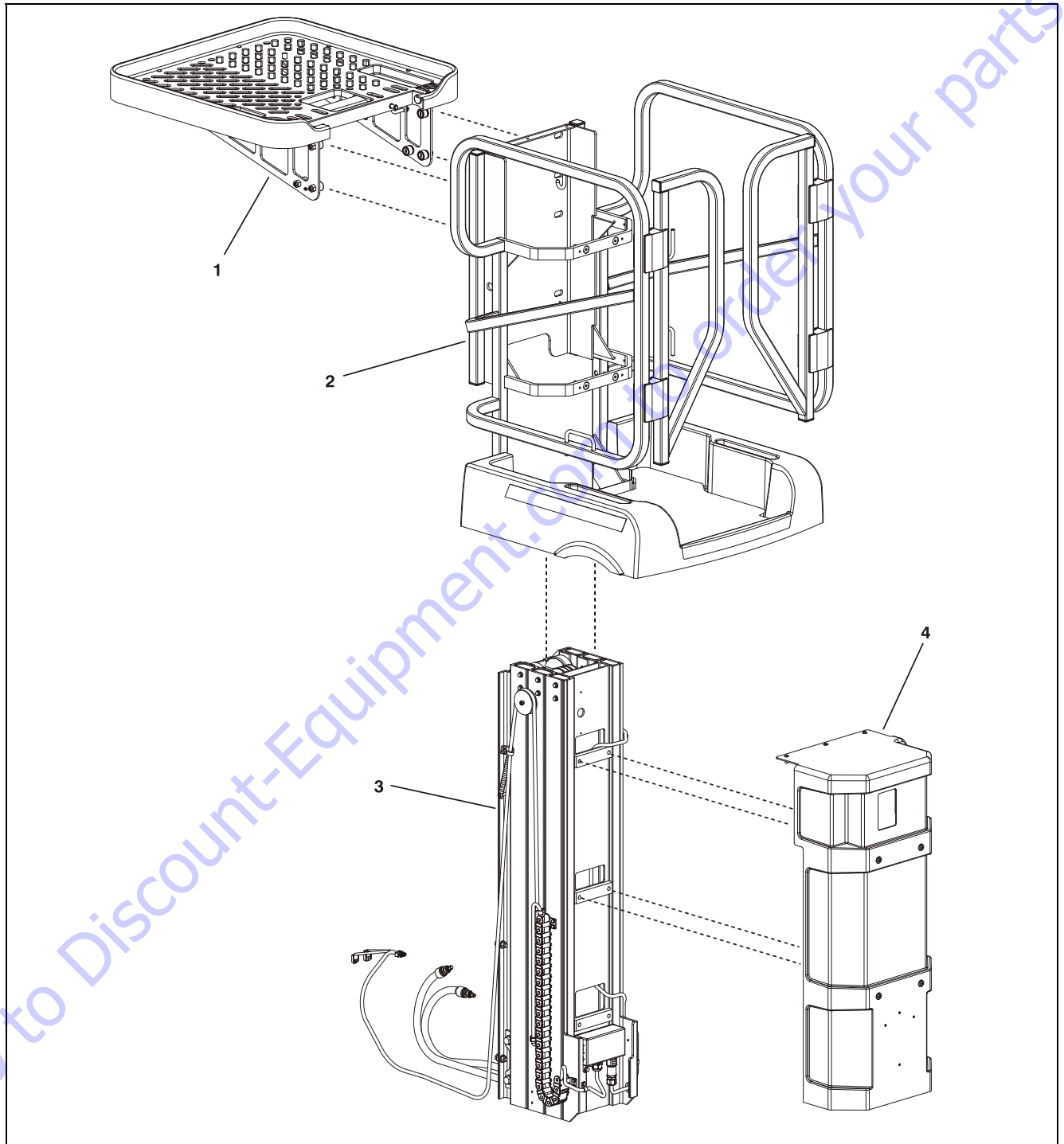
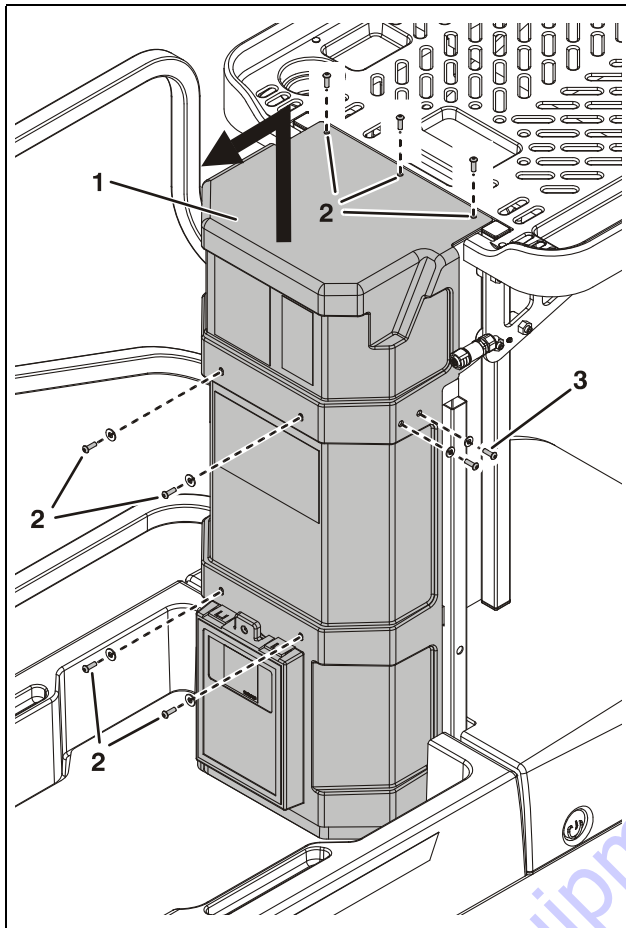

Figure 5-1. Mast Components

- | | |
|--|------------------------|
| 1. Material Handling Tray
(Manual Tray Shown) | 2. Platform Assembly |
| | 3. Mast Assembly |
| | 4. Platform Mast Cover |

5.2 MAST COVER



- 1. Mast Cover
- 2. Screws and Washers (a)
- 3. Platform Console Mounting Screws

Note: Platform shown without right side rails for illustrative purposes only.
 (a) Apply Loctite #242 to threads before final tightening.

5.3 PLATFORM ASSEMBLY

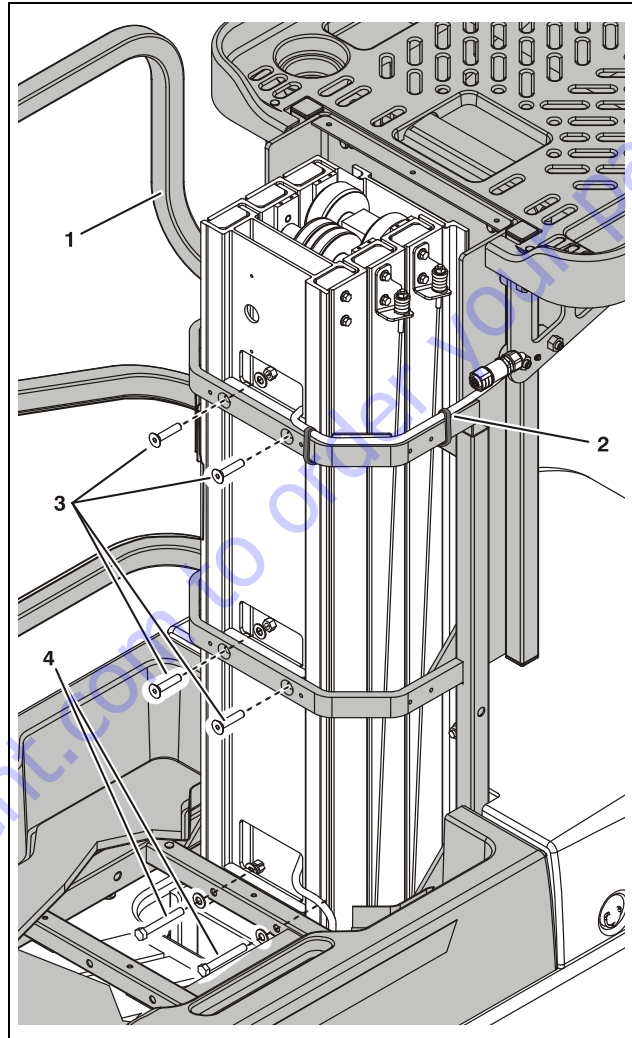

- 1. Platform/Material Tray Assembly
- 2. Tie Straps for Platform Console Harness
- 3. Countersunk Flat Head Socket Screws/Washers and Locknuts
- 4. Hex Head Screws/Washers and Locknuts (a)

Note: Platform shown without right side rails for illustrative purposes only.
 (a) Raise platform and remove the hex head screw/washers and nuts (4).
 While under the platform, unplug the wiring harness to the footswitch enable and the entry gate interlock switches from the platform junction box.

Using suitable lifting equipment, carefully lift the platform/material tray assembly off the mast assembly.

5.4 7 FOOT HEIGHT LIMIT SWITCH (IF EQUIPPED)

Machines prior to SN 0130032507 may be equipped with an optional 7 ft height limit switch. While the standard maximum platform height is 10 ft, this option limits platform height to 7 ft for certain applications.

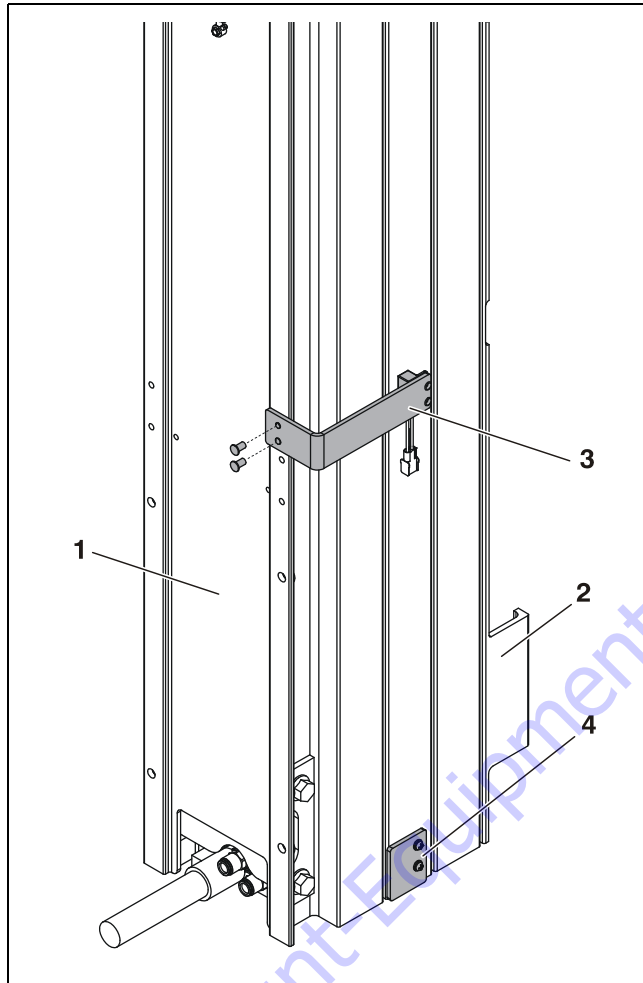

- | | |
|----------------------------|---|
| 1. Mast (Platform Side) | 3. Proximity Switch/Bracket and Fasteners |
| 2. Mast (Front of Machine) | 4. Switch Detection Plate |

Note: Route the proximity switch wire with mast junction box wiring harness and attach with tie straps.

Proximity switch wire connects to AUX 2 input on the main harness.

The ground control module AUX 2 setting must be programmed to "HIGH", and the AUX 2 INHIBIT setting must be set to "0" (refer to Section 4.4, Ground Control Module Programming).

5.5 MANUAL MATERIAL TRAY

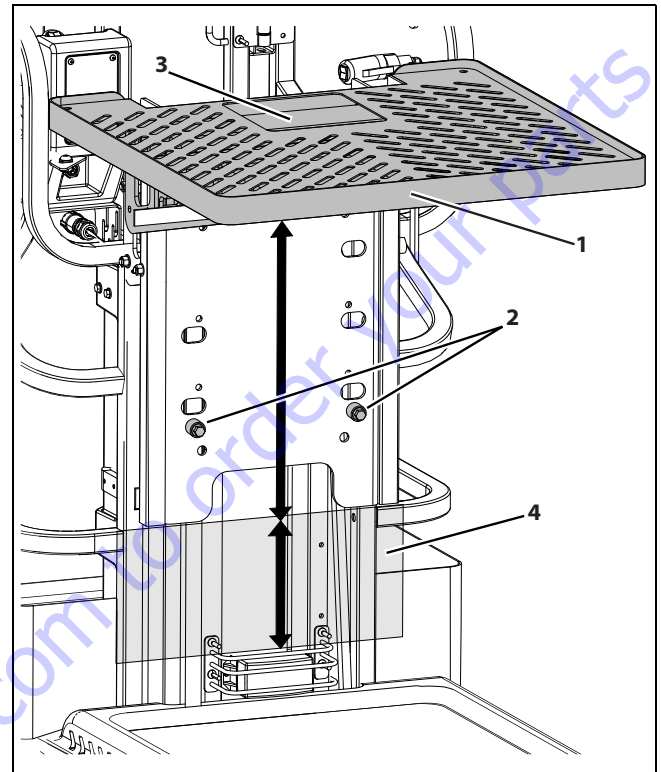

- | | |
|--------------------------|-------------------------|
| 1. Manual Tray Assembly | 3. Tray Release Bar (c) |
| 2. Tray Bottom Stops (b) | 4. Raise Platform (a) |

Note: (a) Raise the platform approximately 2 ft (60 cm) when sliding the tray off the bottom of the mounting rails. Tray will not clear beacon or hood without raising platform.
 (b) Remove stops to slide tray off the bottom of the mounting rails.
 (c) Once bottom stops are removed, carefully lower tray to bottom and slide off mounting rails and move clear of machine. If tray is allowed to drop with stops removed, damage to the amber beacon and hood could occur.

5.6 POWER TRAY DISASSEMBLY

The Power Tray consists of an enclosed power unit attached to the front of the mast and a hydraulically-powered material tray capable of lifting up to 200 lb. A switch on the left side of the mast in the platform controls lift up/down.

The Power Tray is hydraulically-powered via a small lift cylinder connected to a pulley system. The pump and hydraulic reservoir are a single unit mounted to the support plate. Electrical components communicate through a relay mounted above the pump.

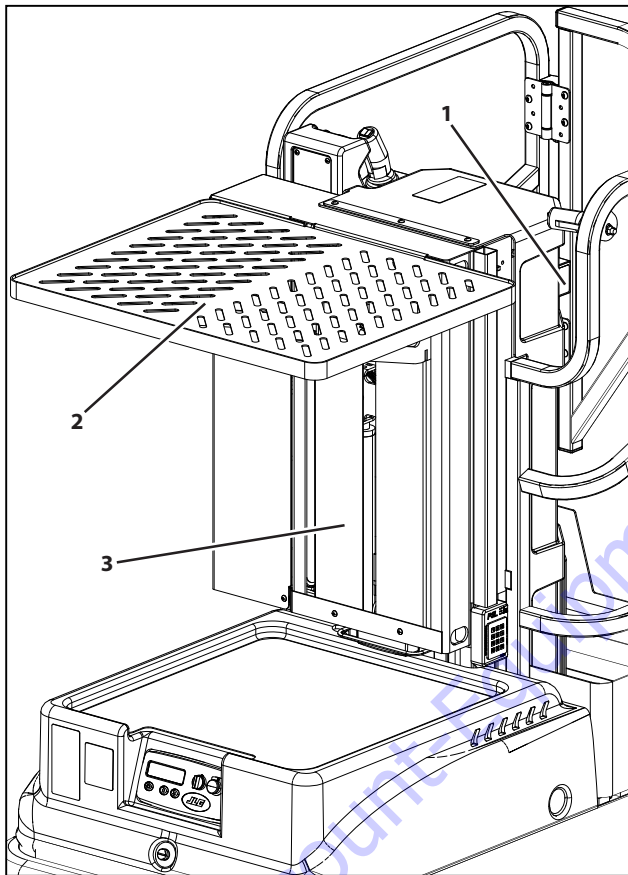

- 1. Power Tray Switch
- 2. Tray Assembly
- 3. Power Unit (Behind Covers)

Covers and Tray Removal

Before beginning removal procedures, fully lower the tray.

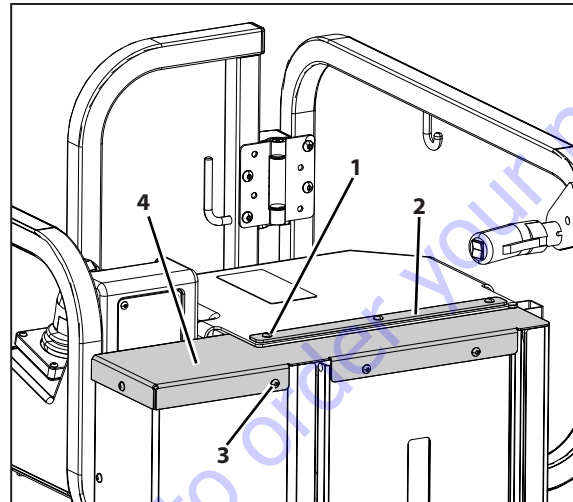

- 1. Screws (3)
- 2. Mast Cover Bracket
- 3. Screws/Nuts (4)
- 4. Power Unit Top Cover

1. Remove three screws (1) from mast cover bracket (2). Retain hardware.
2. Remove four sets of screws/nuts (3) from power unit top cover (4). Remove cover. Retain cover and hardware.

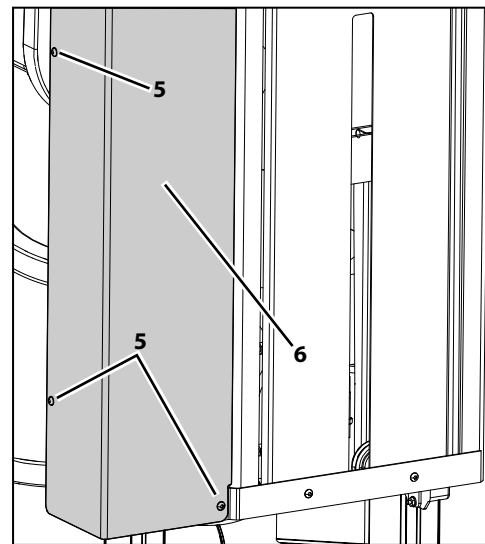

- 5. Screws/Nuts (3)
- 6. Pump Cover

Note: Tray assembly removed for clarity.

3. Remove three sets of screws/nuts (5) from pump cover (6), then remove cover. Retain cover and all hardware.

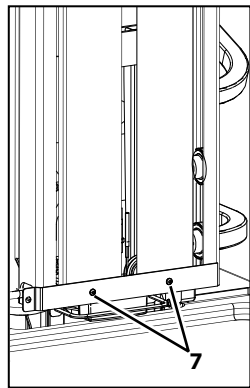

7. Screws/Nuts (2)

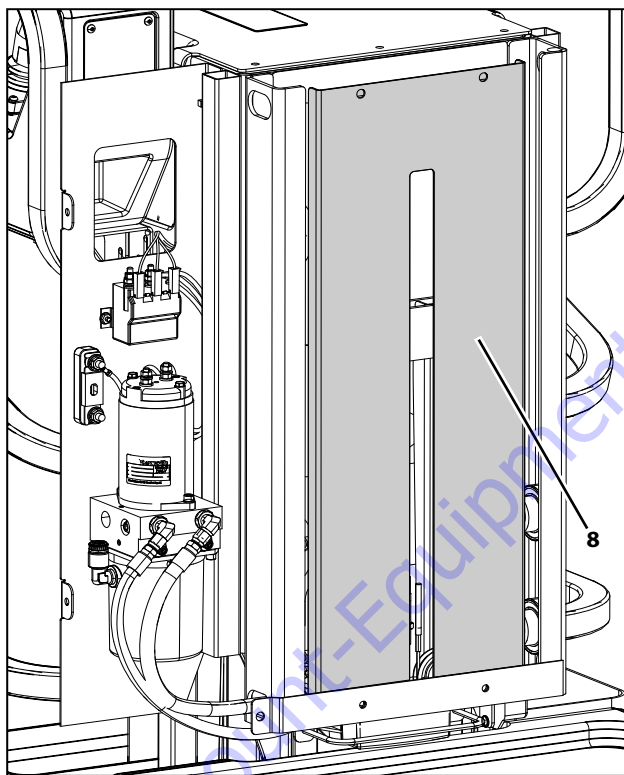

8. Cover Plate

Note: Tray assembly removed for clarity.

4. Remove two sets of screws/nuts (7) from the bottom bracket attached to the cover plate (8) behind the power tray. Remove the cover plate. Retain plate and all hardware.

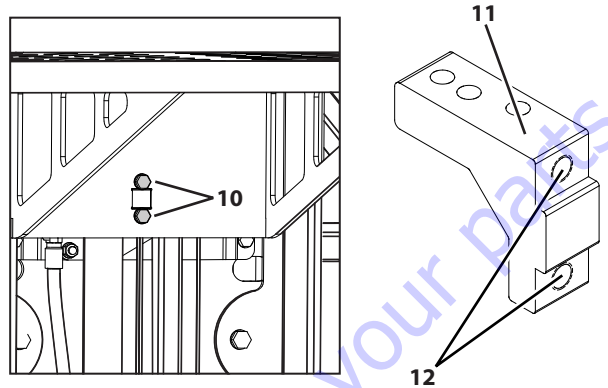

10. Screws/Washers (2)
11. Cable Bracket
12. Tray Mounting Holes

5. Remove two sets of bolts/washers (10) securing tray to cable bracket (11). Retain all hardware.
6. Lift the tray out of the open end of the tracks and set aside. For tray and roller assembly breakdowns, refer to Figure 5-2.

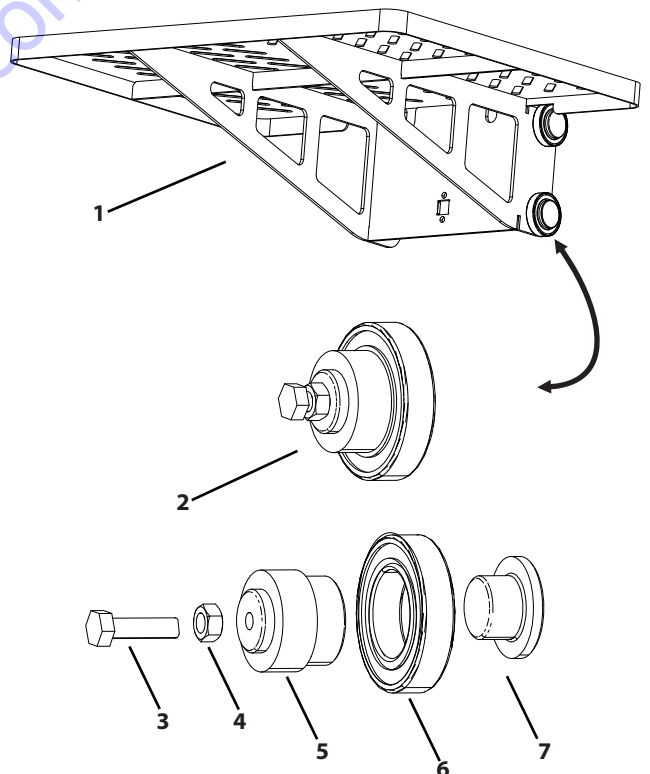

1. Tray Weldment
2. Roller Assembly (4)
3. Bolt
4. Nut
5. Support Pin (attached to tray)
6. Bearing
7. Support Pad

Figure 5-2. Power Tray Roller Assembly

Electrical and Hydraulic Components Removal

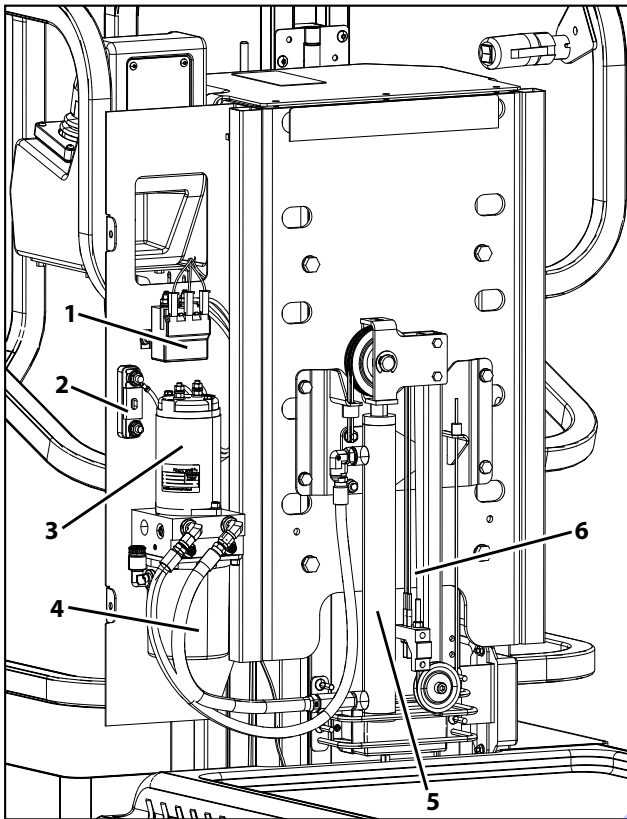

Figure 5-3. Power Unit Components

- | | |
|-------------------|------------------------|
| 1. Relay | 4. Hydraulic Reservoir |
| 2. 35 Amp Fuse | 5. Lift Cylinder |
| 3. Hydraulic Pump | 6. Pulley System |

Note: Some parts removed for clarity.

NOTICE

BEFORE BEGINNING POWER UNIT DISASSEMBLY, DISCONNECT THE LEFT SIDE BATTERY (+) POSITIVE BATTERY TERMINAL.

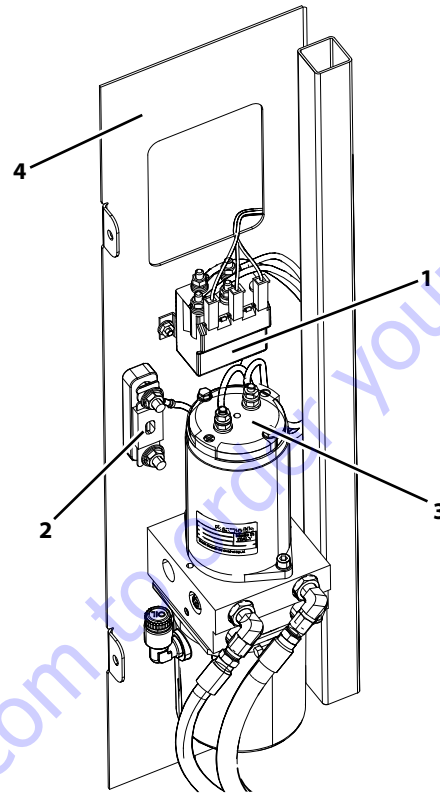

1. Disconnect and tag all electrical wiring from top of the relay (1), fuse (2), and pump (3).
2. If it is necessary to remove or replace the fuse:
 - a. Remove the bolts, nuts and washers attaching the fuse to the pump support plate (4).
 - b. If replacing the fuse, mount to the same location and attach with existing hardware.
3. If it is necessary to remove or replace the relay:
 - a. Remove the bolts, nuts, and washers attaching the relay to the pump support plate. Retain all hardware.
 - b. If replacing the relay, mount to the same location and attach with existing hardware.

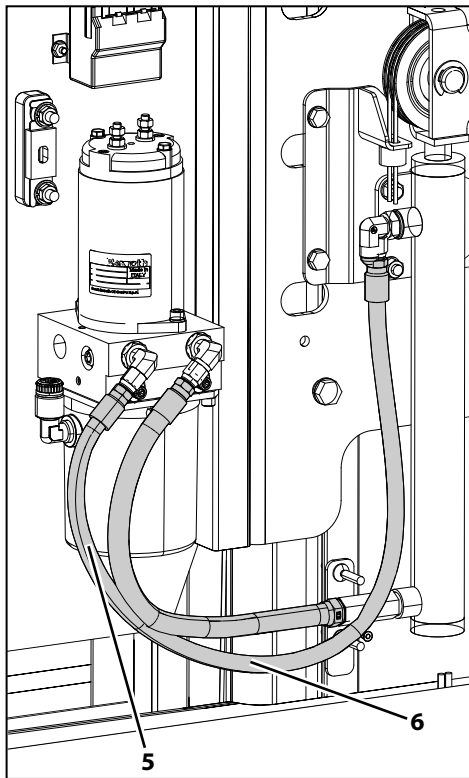

Note: Some parts removed for clarity.

4. Disconnect, tag, and cap hydraulic hoses (5 & 6).

Note: Place a suitable container underneath the assembly to catch any hydraulic oil leaks.

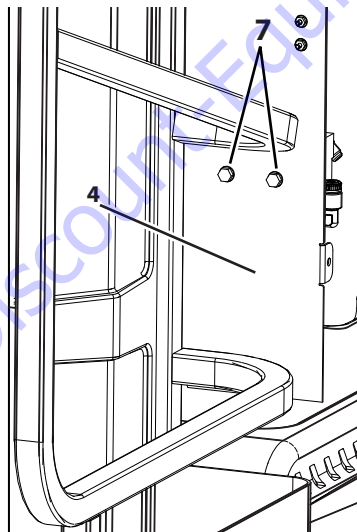

5. To remove pump assembly, remove two sets of bolts/washers (7) attaching assembly to the cover plate (4). Retain all hardware.
6. Once pump assembly has been removed, transfer to a clean, flat surface, and keep upright.

Pulley System Disassembly

Once the electrical and hydraulic components have been disconnected/removed from the machine, the pulley system connected to the power tray lift cylinder may be removed.

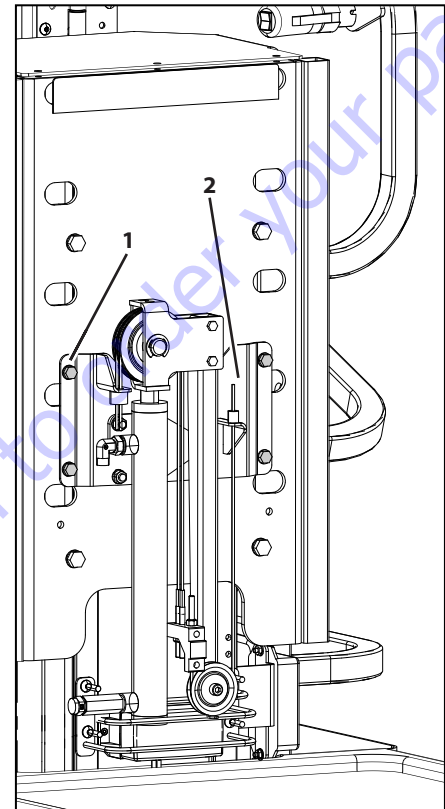

Note: Some parts removed for clarity.

1. Remove four sets of bolts/nuts/washers (1) securing the cylinder mounting bracket (2) to the platform assembly. Retain all hardware.
2. Carefully lift out the pulley system and set it on a clean, flat surface.

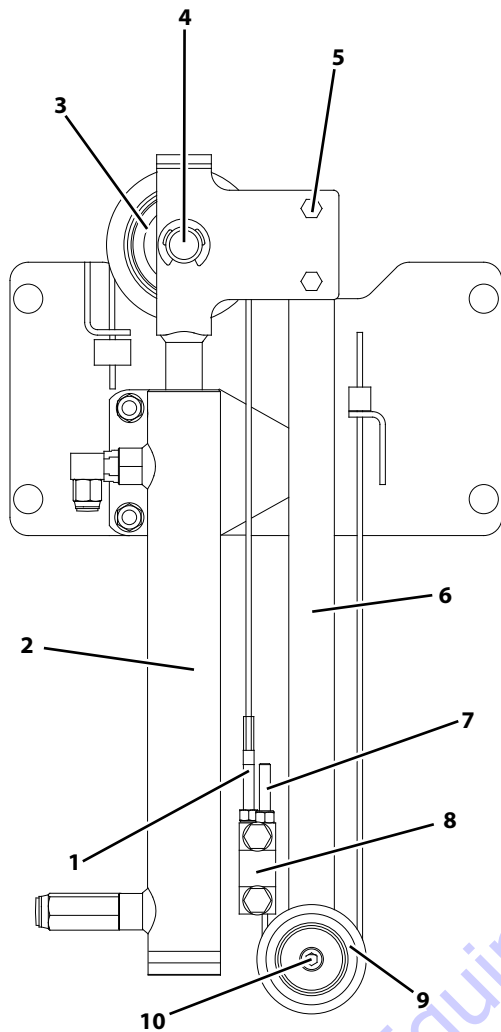

- | | |
|-------------------------|---------------------|
| 1. Double Cable | 6. Link |
| 2. Lift Cylinder | 7. Single Pulley |
| 3. Double Pulley | 8. Cable Bracket |
| 4. Pin/Circlip | 9. Single Pulley |
| 5. Screw/Nut/Washer (2) | 10. Bolt/Nut/Washer |

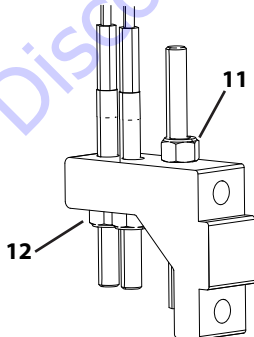

- | |
|-------------------------|
| 11. Nut (Single Cable) |
| 12. Nuts (Double Cable) |

Figure 5-4. Pulley System Overview

To complete this procedure, refer to Figure 5-4.

1. Loosen the nut (11) at the threaded end of the single cable (7) at the cable bracket (8). Remove the cable and retain hardware.
2. Loosen the nuts (12) at the threaded ends of the double cable (1) at the cable bracket. Remove cable and retain hardware.
3. Remove hardware (10) securing single pulley (9) to the assembly. Set aside pulley and hardware.
4. Remove hardware (4) securing double pulley (3) to the assembly. Set aside pulley and hardware.
5. Remove and retain hardware (5) securing link (6) to cylinder (2).

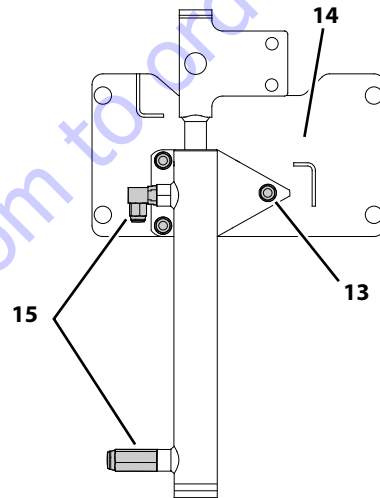

- | | |
|-------------------------------|--------------|
| 13. Bolt/Nut/Washer (3) | 15. Fittings |
| 14. Cylinder Mounting Bracket | |

6. Remove and retain three sets of bolts/nuts/washers (13) securing cylinder to the mounting bracket (14).
7. Remove hydraulic fittings (15) from the cylinder.

Power Tray Lift Cylinder

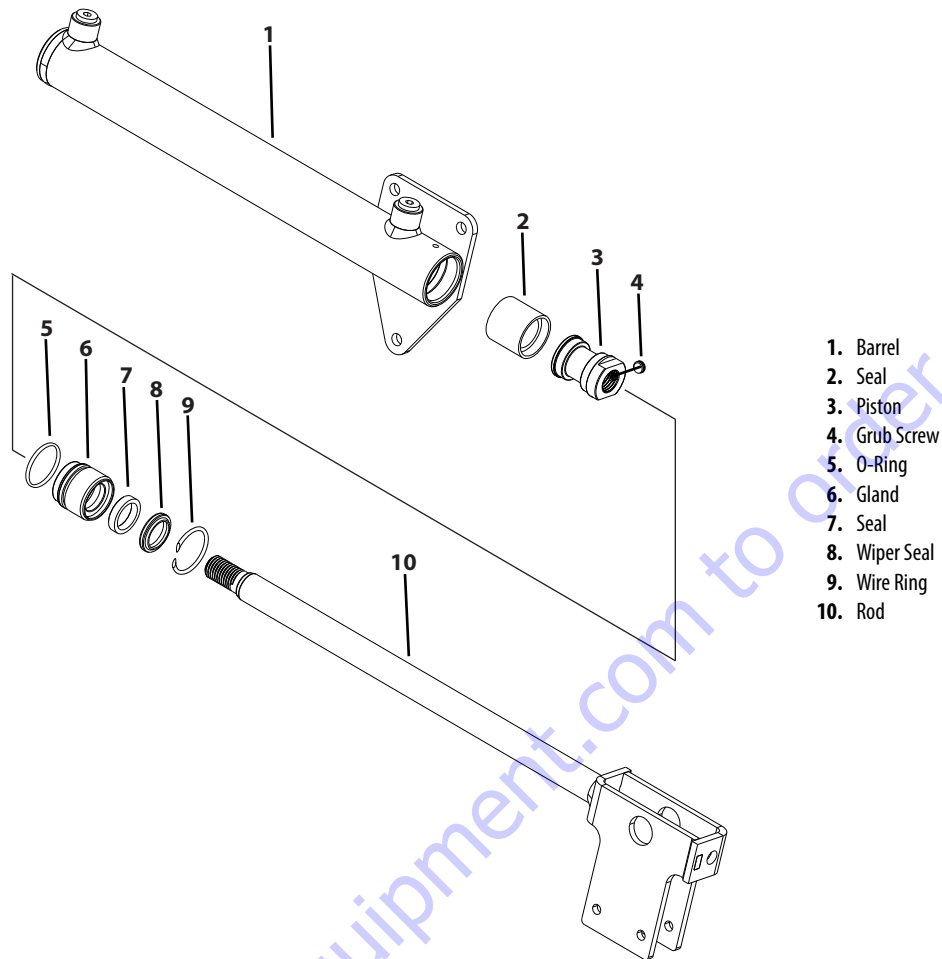

1. Barrel
2. Seal
3. Piston
4. Grub Screw
5. O-Ring
6. Gland
7. Seal
8. Wiper Seal
9. Wire Ring
10. Rod

Disassembly

1. Push gland (6) back into cylinder to approximately 15 mm from the end of the tube.
2. Line up one end of the wire ring (9) with the hole in the outside of the tube.
3. Use a tool to push the wire ring out of its groove. Remove through end of tube assembly.
4. Remove complete rod, piston, and gland assembly. Keep ports open to allow air into cylinder.
5. To remove piston head (3), remove grub screw (4). Loosen piston head using 24 mm spanner and unscrew.

Note: Clamp the rod assembly at rod end to protect chrome rod.

6. Pull gland (6) off rod assembly.
7. Change seals (2, 7, & 8).

Reassembly

1. Fit gland back onto rod. Ensure seals are not damaged by rod threads.
2. Apply Loctite 243 (or equivalent) to rod thread and fit piston head. Torque to 61.2 ft.lb. (83 Nm).
3. Apply Loctite 222 (or equivalent) to grub screw. Fit grub screw and torque to 8.9 ft.lb (12 Nm).
4. Fit complete rod, piston, and gland assembly into tube assembly.
5. Push wire ring through end of tube assembly until it is fitted into its groove.

5.7 POWER TRAY INSTALLATION

Pulley System Assembly

1. Attach fittings to lift cylinder. Torque each fitting to 14 ft.lb. (19 Nm).
2. Attach cylinder to mounting bracket and secure with reserved hardware.

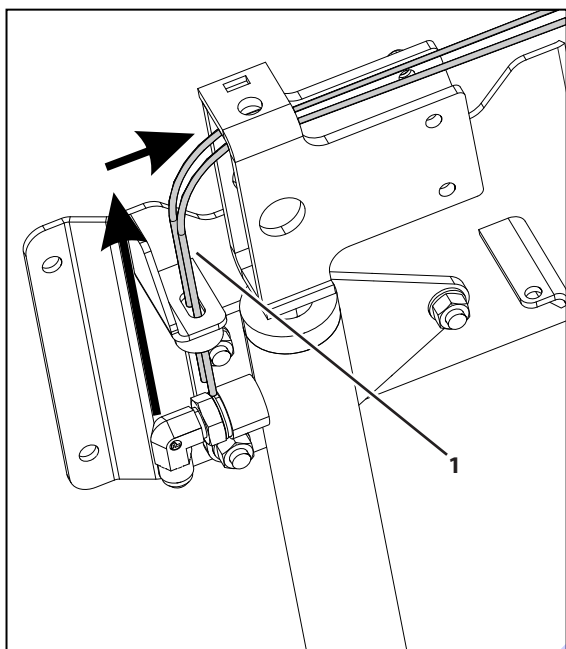

3. Route the threaded ends of the double cable (1) up through the slot on the left side of the cylinder mounting bracket.

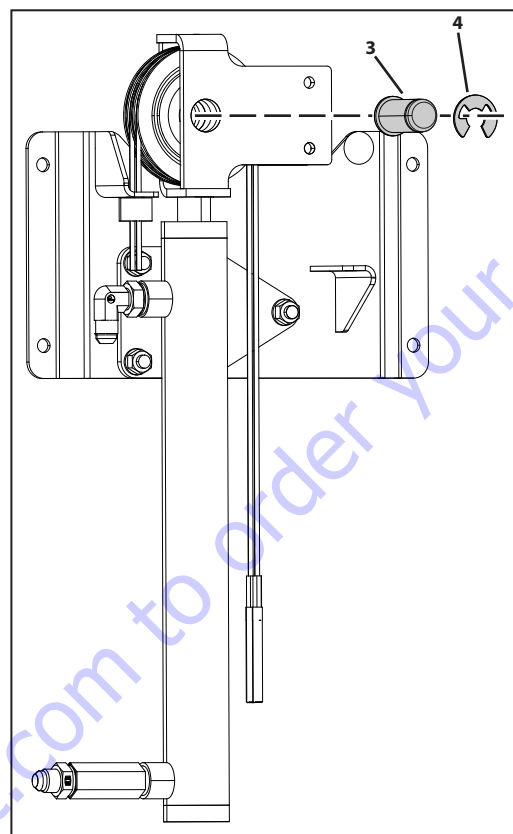

5. Install pin (3) and circlip (4).

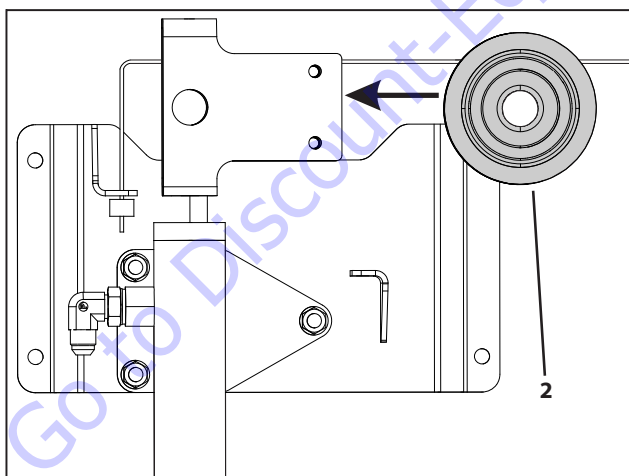

4. Insert double pulley wheel (2) into the mounting bracket at the top of the cylinder assembly. Ensure holes are aligned and double cable is set in grooves and routed along top of wheel.

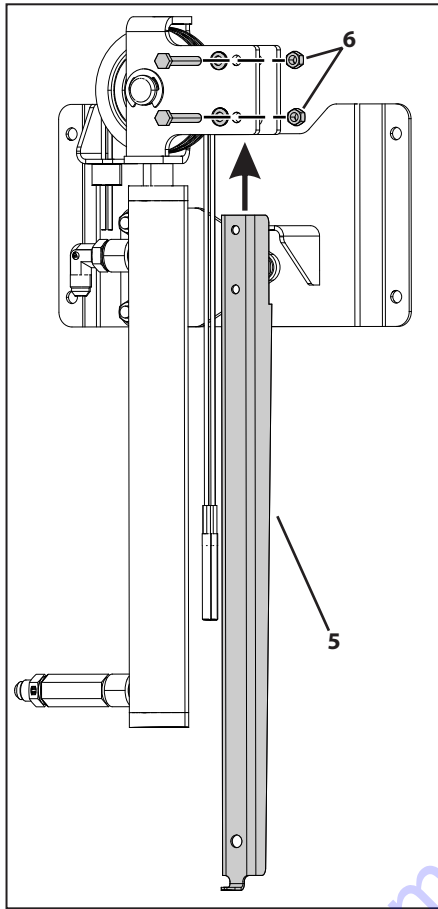

6. Install link (5) and secure with hardware (6).

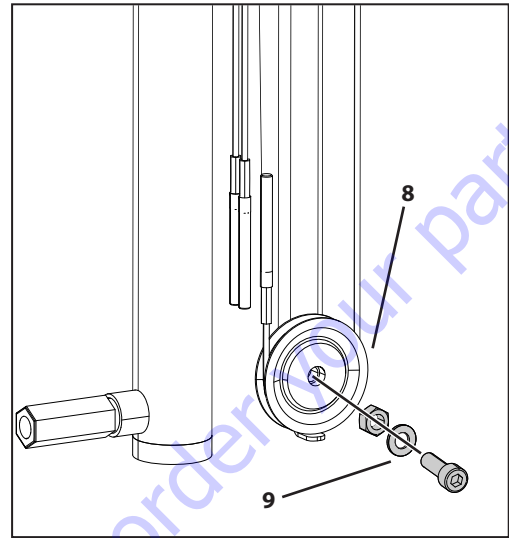

8. Install single pulley wheel (8) to the bottom of the link and secure with hardware (9). Ensure single cable is set in groove and routed along the bottom of the wheel.

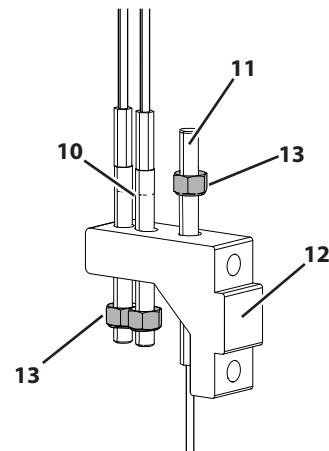

9. Pull the threaded ends of the double cable (10) through holes on the cable bracket (12). Pull the threaded end of the single cable (11) through the hole on the cable bracket.
 10. Install nuts (13) to each threaded end of the cables. Tighten nuts one at a time, evenly from cable ends.

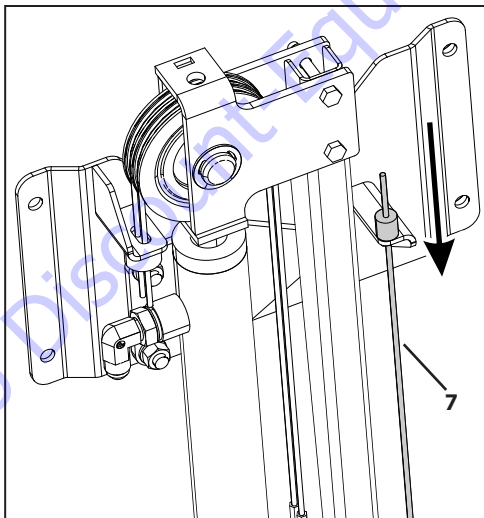

7. Route the threaded end of the single cable (7) down through the slot on the right side of the cylinder mounting bracket.

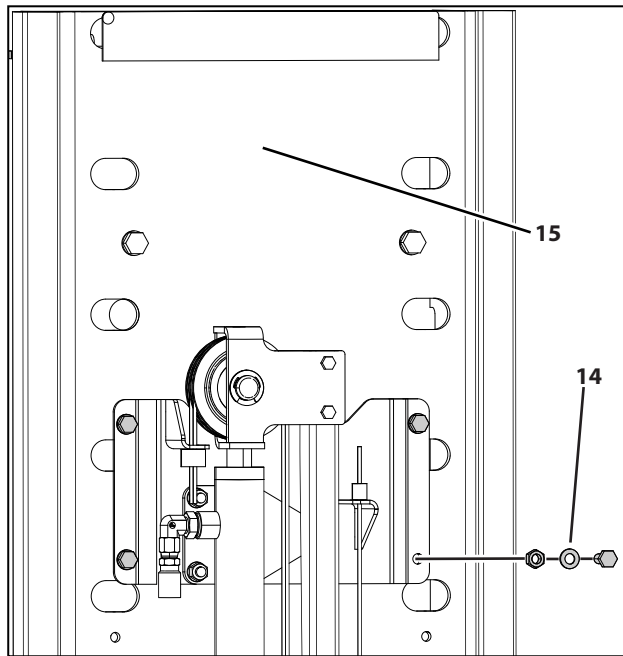

11. Install hardware (14) securing cylinder mounting bracket to platform assembly (15).

2. Connect all tagged electrical wiring to relay, fuse, and hydraulic pump.
3. Connect all tagged hydraulic hoses from pump to cylinder. Torque to 14 ft.lb. (19 Nm).

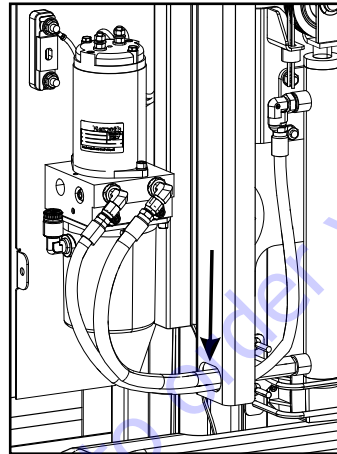

Note: Ensure hoses connected to bottom of lift cylinder are routed through the hole at the bottom of the track weldment.

Electrical and Hydraulic Components Installation

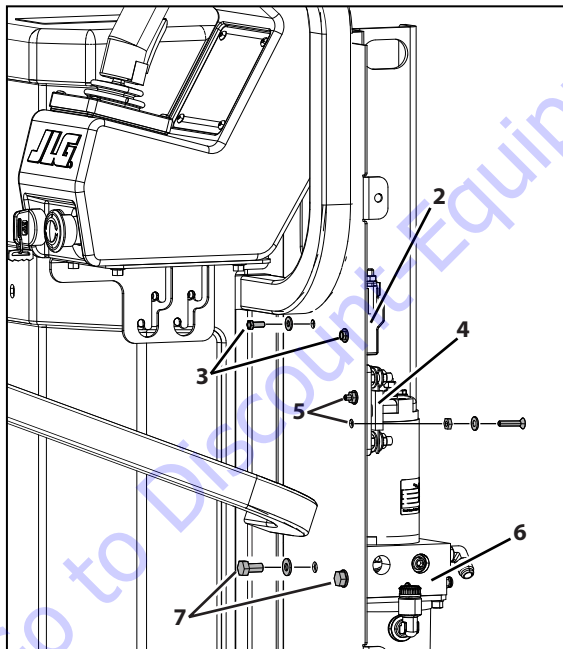

1. Install the following components (if they were removed during disassembly) to the pump support plate (1) using retained hardware:
 - a. Relay (2 & 3)
 - b. Fuse (4 & 5)
 - c. Hydraulic Pump (6 & 7)

Covers and Tray Installation

If the tray was removed and the rollers disassembled, (refer to Figure 5-2.), ensure they are reassembled and returned to the machine before installing covers.

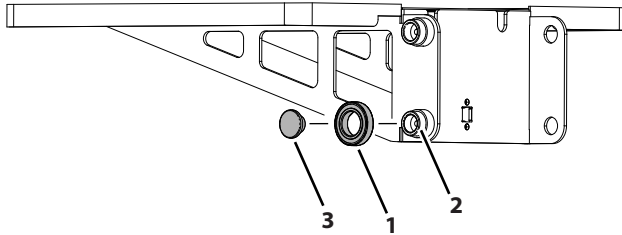

1. Install bearings (1) onto support pins (2) on both sides of tray.
2. Install support pads (3) into bearings on both sides of tray.

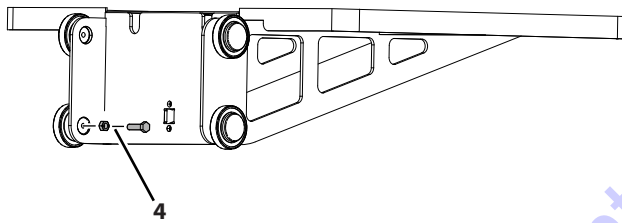

3. Install hardware (4) into support pins on both sides of tray.

Note: Do not tighten hardware at this point in assembly, as it will be adjusted in the following steps.

4. Lift up tray and set into the open end of the tracks. Slide - do not drop - the tray to the bottom of the tracks.
5. Adjust support pads on both sides of tray to track width by tightening hardware.
6. Attach tray to cable bracket using retained hardware.
7. Slide cover plate down behind tray. Attach to the bottom bracket using retained hardware.
8. Attach pump cover using retained hardware.
9. Attach power unit top cover using retained hardware.
10. Attach mast cover bracket using retained hardware.
11. Cycle the power tray several times; check for leaks around the bottom of the power unit and smooth operation.

5.8 HYDRAULIC LINE DISCONNECT TOOL

The extend and return hydraulic line couplings and hose fittings on this machine require special tool JLG P/N 7027247 to remove and install them.

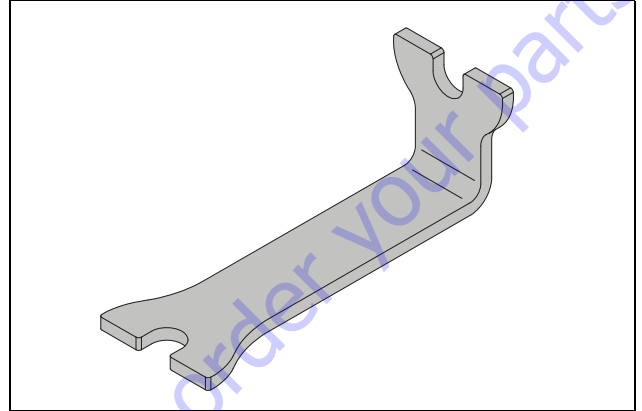

Figure 5-5. Push Type Hydraulic Line Removal

⚠ CAUTION

FULLY LOWER MAST TO RELIEVE SYSTEM PRESSURE BEFORE REMOVING ANY HYDRAULIC LINES. CAREFULLY LOOSEN REQUIRED FITTINGS. WEAR SAFETY PROTECTION EQUIPMENT WHEN WORKING WITH HYDRAULIC SYSTEMS.

In-Line Style Fittings



Step 1. Prior to disconnection, ensure that system is not under pressure.

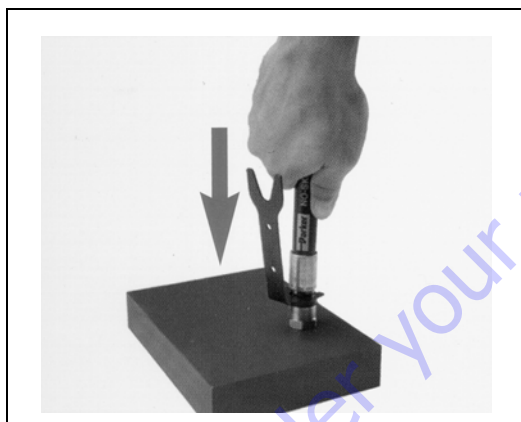

Step 4. Gently push hose assembly into coupling body (see directional arrow).

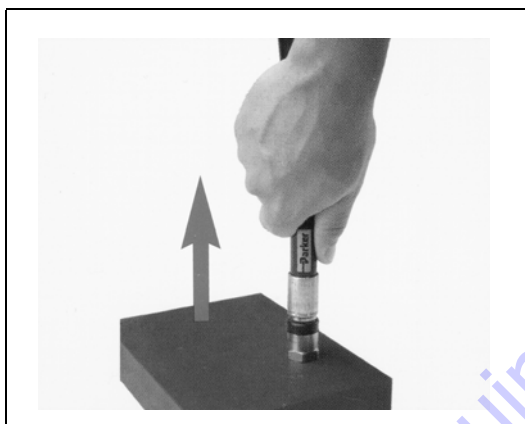

Step 2. Pull on hose assembly to create a gap between the dust boot and hose fitting shoulder.

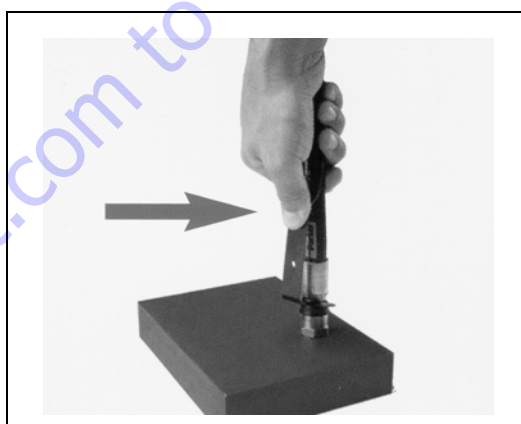

Step 5. Maintaining slight pressure on the hose assembly, actuate the tool (see arrow).



Step 3. Insert the disconnect tool in the gap created between the dust boot and hose fitting shoulder.

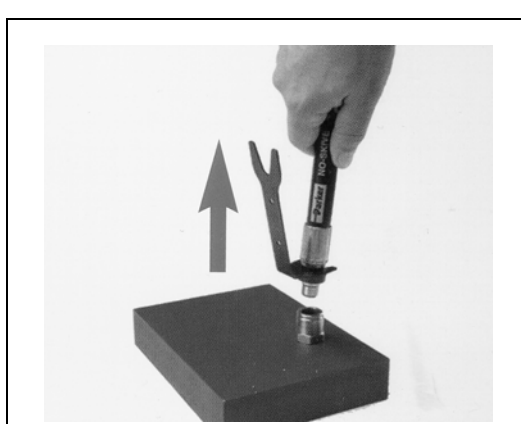

Step 6. Release the tool and pull on hose assembly to complete disconnection.

Angled-Style Fittings

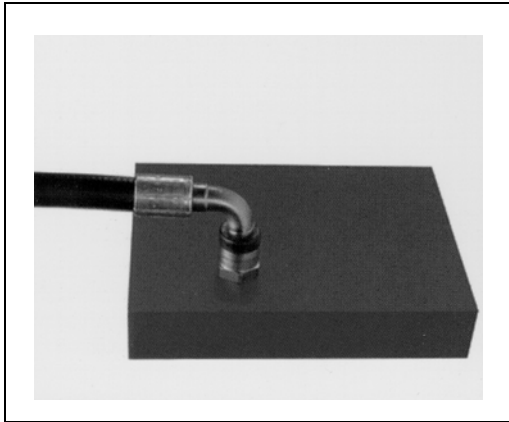

Step 1. Prior to disconnection, ensure that system is not under pressure.

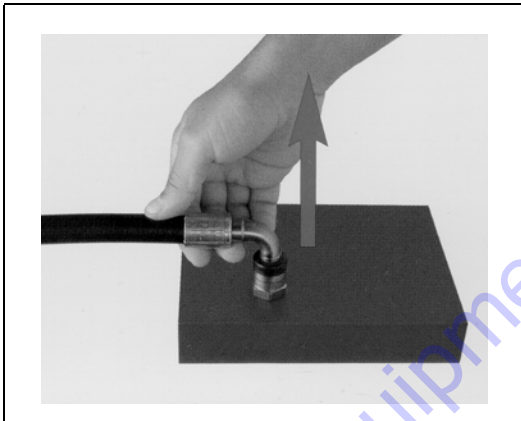

Step 2. Pull on hose assembly to create a gap between the dust boot and hose fitting shoulder.

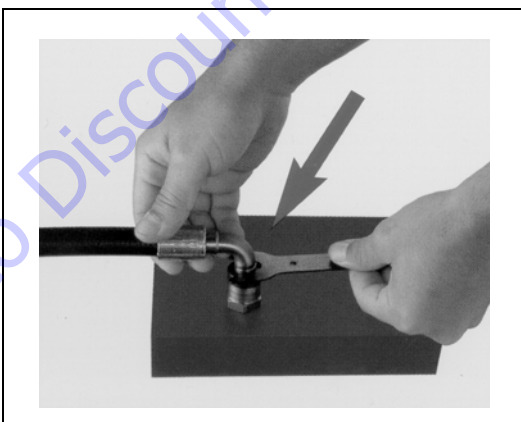

Step 3. Insert the disconnect tool in the gap created between the dust boot and hose fitting shoulder.

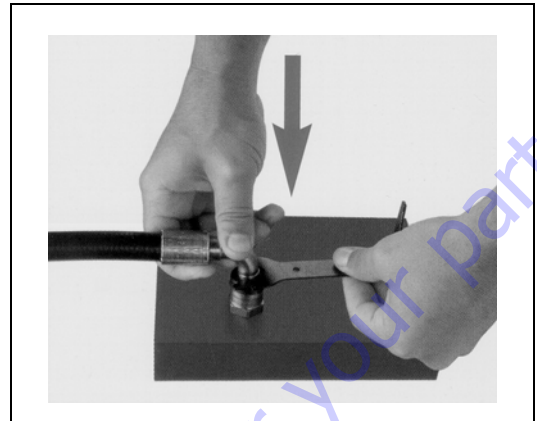

Step 4. Gently push hose assembly into coupling body (see directional arrow).

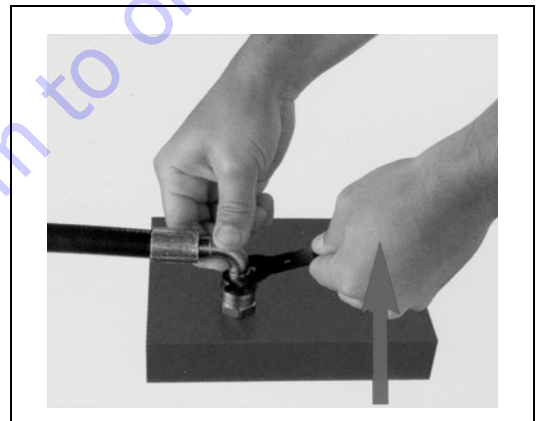

Step 5. While maintaining slight pressure on hose assembly, actuate tool (see arrow).

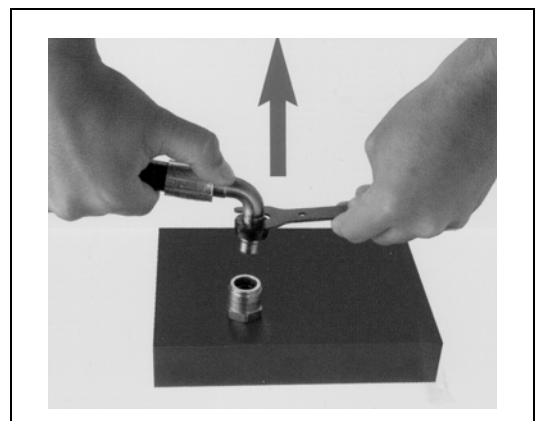

Step 6. Pull on hose assembly to complete disconnection.

5.9 MAST REMOVAL

1. In order to remove the mast assembly, first elevate the platform approximately 4 ft (1.2 m), then remove the following components:
 - Front Hood (Section 3.2)
 - Drive Motors Cover (Section 3.2)
 - Platform/Material Tray Assembly (Section 5.3)
2. Once those components have been removed, lower the platform completely, using the Manual Descent Valve if necessary, then remove the following components:
 - Platform Control Console (Section 4.2)
 - Mast Cover (Section 5.2)
 - Platform/Material Tray Assembly (Section 5.3)
 - Battery Charger Assembly (Section 3.7)
3. Unplug the platform control cable (P4) connector at the ground control module.
4. Unplug and remove the amber beacon mounted on the front of the mast assembly.
5. Disconnect and cap the hydraulic extend and return lines from the hydraulic cylinder either on the valve block at the bottom of the cylinder or at the pump assembly. (See Section 5.8 for special tool instructions).
6. Using an overhead crane or suitable lifting device capable of supporting the weight of the mast assembly, attach a sling strap to the mast.

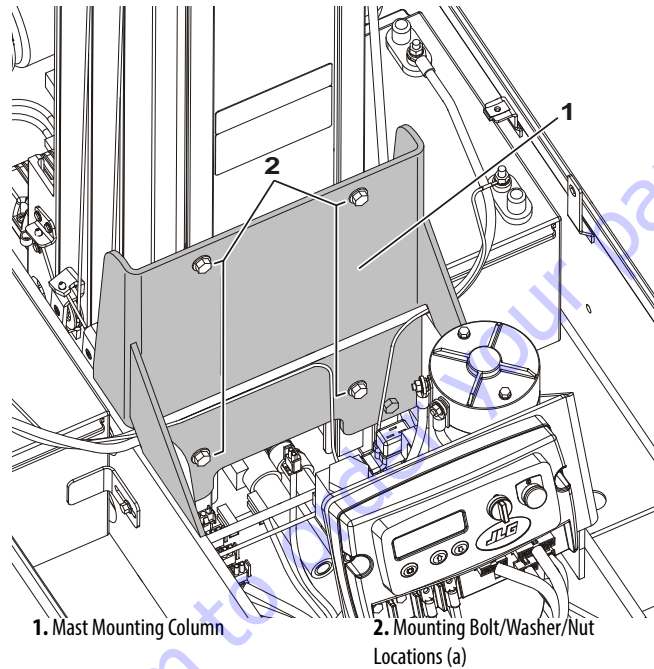

Note: (a) Apply Loctite #271 to bolt threads on final assembly.

Note: When lifting the mast out of the base frame be careful with the manual descent valve and extend/return lines protruding from the bottom front of the mast assembly.

8. Remove the four mast attach bolts with washers and nuts securing the mast to the mounting column.
9. Carefully lift the mast off the base frame and place on a suitable work surface.

Mast Installation

1. Reverse the Mast Removal instructions to reinstall mast.
2. Once assembly is complete, cycle the mast up and down several times, then check the oil level in the hydraulic reservoir.

5.10 MAST DISASSEMBLY

The mast sections are constructed of extruded aluminum, protected with an anodized surface finish. The mast sections are interlocked into each other when assembled by internally mounted slide pads at the top and bottom of each mast section. These slide pads run up and down in slide pad channels on each side of the mast.

The mast assembly contains four sections that are extended/retracted by chains.

Procedure

1. After the mast assembly has been removed from the machine, lay the mast assembly down on a suitable work table with the platform mounting section on top, facing up.
2. Remove the sequencing cables, platform junction box and hardware from the sides of the mast assembly. Also remove the extend and return hydraulic lines from the bottom of the lift cylinder.

Note: If equipped with the OPTIONAL 7 ft. height limiting proximity switch, if necessary, remove the fasteners attaching the bracket and switch to the left side of the mast assembly. (See Section 5.4, 7 Foot Height Limit Switch (If Equipped)).

Mast Section 4 (Platform Mount)

1. Remove chain adjust nuts from threaded ends of chain attached to the chain anchor plate (*lower*) on BOTTOM end of mast section 4 (*platform mounting section*). Push threaded ends of chain through anchor plate.
2. At the TOP of mast section 3, pull chains out and allow to hang loose. (*Be certain floor surface is clean and free of any metal chips or debris which may stick to lubricated chains.*)

Note: When sliding mast sections apart, be careful not to scratch or score the anodized surface in the slide pad channels.

3. Carefully slide mast section 4 out the BOTTOM of mast section 3 rails. Disassemble slide pads, shims and chain anchor plate from mast section 4, if necessary.

Mast Section 3

1. Remove chain adjust nuts from threaded ends of chains attached to the chain anchor plate (*lower*) on BOTTOM end of mast section 3. Push threaded ends of chains through anchor plate.
2. At TOP of mast section 2, pull chains out and allow to hang loose. (*Be certain floor surface is clean and free of any metal chips or debris which may stick to lubricated chains*)

Note: When sliding mast sections apart, be careful not to scratch or score the anodized finish in the slide pad channels.

3. Slide mast section 3 out the TOP of mast section 2 enough to allow removal of the sheave wheel assembly.
4. Remove countersunk-flathead screws securing chain sheave wheel assembly attach bars on both side rails at TOP of mast section 3 and remove sheave wheel assembly.
5. Carefully slide mast section 3 out the BOTTOM of section 2. Remove slide pads, shims and cable anchor plate, if necessary.

Mast Section 2

Note: Since the lift cylinder rod is still attached to the anchor block at the top of the section 2 mast assembly, you will need to temporarily uncap the extend and return hydraulic lines to allow mast section 2 to be extended in the next step. Capture any hydraulic fluid that may flow out of the lines and recap the lines once section is extended.

1. Slide mast section 2 out TOP of mast section 1 far enough to allow access to the chain assembly anchor block/sheave wheel assembly.
2. On the underside of the mast assembly, remove the snap ring securing the anchor pin running through the small chain equalizer plate, the cylinder anchor block and the cylinder rod.
3. Push or lightly tap the anchor pin up and remove. Lay the small chain set aside.
4. Remove countersunk-flathead screws securing chain anchor block/sheave wheel assembly attach bars on both side rails at TOP of mast section 2 and remove the anchor block/sheave wheel assembly.

Note: When sliding mast sections apart, be careful not to scratch or score the anodized finish in the slide pad channels.

5. Carefully slide mast section 2 out the TOP of section 1. Remove slide pads and shims, if necessary.

Mast Section 1

1. Remove the four large screws (2 each side) attaching the lift cylinder mounting block to mast section 1. Slide the cylinder out of the mast section and move to a suitable work surface.
2. At the top end of mast section 1, remove the pin attaching the chain anchor block to the mast and remove chain/anchor block assemblies from the mast and lay aside.
3. Remove slide pads and shims from mast section 1, if necessary.

5.11 CYLINDER DISASSEMBLY

To complete this procedure, refer to Figure 5-6.

1. Before disassembling the cylinder, clean away all dirt and foreign substances from openings, particularly the head area.

Note: Always protect the chrome surface of the cylinder rod during assembly and disassembly. Any damage to this surface will require replacement of the rod.

2. Extend the rod until the piston bottoms out against the cylinder head.
3. Compress the head retraining ring enough to allow the cylinder head to be removed.
4. Carefully slide the head/rod/piston assembly out of the cylinder tube. A gentle tap on the head assembly may be required to remove the head from the cylinder tube.
5. Place the head/rod/piston assembly on a surface that will not damage the chrome.
6. Remove the piston locknut and separate the piston from the rod.
7. Slide the head off the rod from the piston end.

Note: When removing the old seals use only blunt tools, be sure there are no sharp edges that may damage the seal grooves during removal. Scratching the groove may cause by-pass.

8. Remove and discard all old seals.

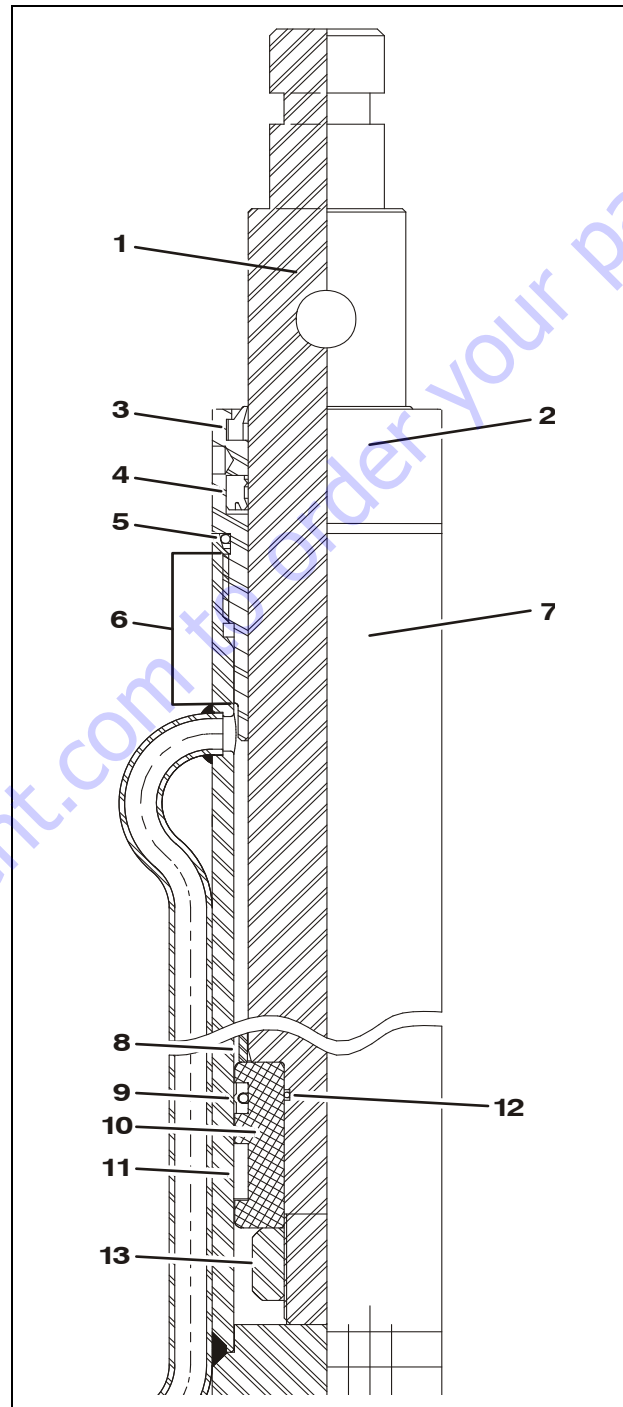

Figure 5-6. Lift Cylinder Component Cross-Section

- | | | |
|------------------|---------------------|-------------------------|
| 1. Cylinder Rod | 6. Apply Anti-Seize | 10. Piston |
| 2. Cylinder Head | 7. Cylinder Tube | 11. Wear Ring |
| 3. Rod Wiper | 8. Spacer | 12. Piston O-Ring |
| 4. Rod Seal | 9. Piston Seal | 13. Piston Lock Nut (a) |
| 5. O-Ring | | |

Note: (a) Torque 100 - 120 ft. lbs.

Lift Cylinder Component Inspection

Cylinder Rod

There should be no scratches or pits deep enough to catch the fingernail. Pits that go to the base metal are unacceptable. Scratches that catch the fingernail but are not to the base metal, less than 0.5" long and primarily in the circumferential direction are acceptable provided they cannot cut the rod seal. Chrome should be present over the entire surface of the rod and the lack thereof is unacceptable. In the event that an unacceptable condition occurs, the rod should be repaired or replaced.

Cylinder Head

Visually inspect the inside bore for scratches or polishing. Deep scratches are unacceptable. Polishing indicates uneven loading and when this occurs, the bore should be checked for out-of-roundness. If out-of-roundness exceeds 0.007", this is unacceptable. Check the condition of the dynamic seals (wiper, rod seals) looking particularly for metallic particles embedded in the seal surface. It is normal to cut the static seal on the retaining ring groove upon disassembly. Remove the rod seal, static o-ring and backup and rod wiper. Damage to the seal grooves, particularly on the sealing surfaces, is unacceptable. In the event that an unacceptable condition occurs, the head should be replaced.

Piston

Visually inspect the outside surface for scratches or polishing. Deep scratches are unacceptable. Polishing indicates uneven loading and when this occurs, the diameter should be checked for out-of-roundness. If out-of-roundness exceeds 0.007", this is unacceptable. Check the condition of the dynamic seals and bearings looking particularly for metallic particles embedded in the bearing and in the piston seal surface. Remove the seals and bearings. Damage to the seal grooves, particularly on the sealing surfaces, is unacceptable. In the event that an unacceptable condition occurs, the piston should be replaced.

Tube Assembly

Visually inspect the inside bore for scratches and pits. There should be no scratches or pits deep enough to catch the fingernail. Scratches that catch the fingernail but are less than 0.5 inch long and primarily in the circumferential direction are acceptable provided they cannot cut the piston seal. The roughness of the bore should be between 10 and 20 μ inches RMS. Significant variation (greater than 8 μ inches difference) are unacceptable. In the event that an unacceptable condition occurs, the tube assembly should be repaired or replaced.

Cylinder Assembly

To complete this procedure, refer to Figure 5-6.

1. Rinse the inside of the tube with hydraulic fluid and allow to drain. A high pressure rinse followed by a wipe with a lint-free rag is preferable. Clean all internal components of any foreign material.
2. Lubricate the head and all seals with hydraulic fluid prior to installation. Install the seal, wiper, o-ring, back-up ring, and retraining ring to the cylinder head.
3. Lubricate the piston and all components with hydraulic fluid. Install the seal and wear ring to the piston.

Note: Re-check that seals are not twisted or pinched and are properly seated.

4. Place the rod on a clean table. Install the static piston o-ring seal into the groove on the piston end of the rod.
5. Install the head followed by the piston onto the rod noting the proper orientation of each component. Torque the piston nut to 100-120 ft. lbs.
6. When the rod assembly is ready to be installed into the tube, liberally apply an anti-seize lubricant to the cylinder head surface which slides into the cylinder tube.
7. Next dip the entire rod assembly into hydraulic fluid and stuff this assembly into the tube. Watch the seals as they pass over the rod port (*if visible*) to be sure they are not nicked or cut.
8. Install the head until the retaining ring seats in its groove.

Manual Descent Valve

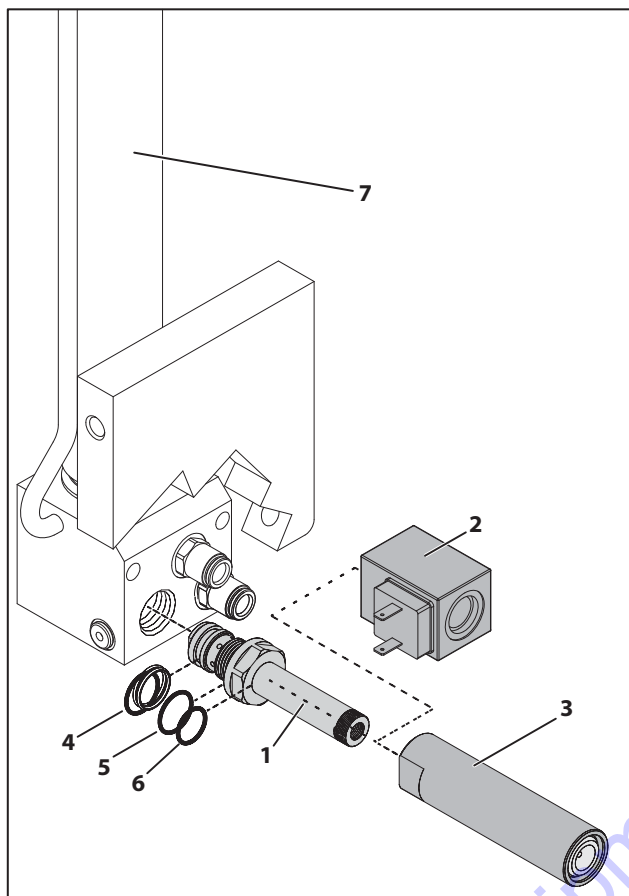

- | | |
|----------------------------|----------------------------------|
| 1. Lift Down Valve (a) | 4. O-Ring with Backing Rings (a) |
| 2. Valve Solenoid (b) | 5. Valve O-Ring (a) |
| 3. Manual Release Assembly | 6. Solenoid O-Ring (a) |

Note: (a) Coat all o-rings with clean hydraulic fluid before assembling.
 (b) Mount with electrical terminals pointing to right side of machine.

Remote Manual Descent (If Equipped)

The Remote Manual Descent option connects to the manual descent valve. It enacts the manual release assembly through an external release knob located at the rear of the machine.

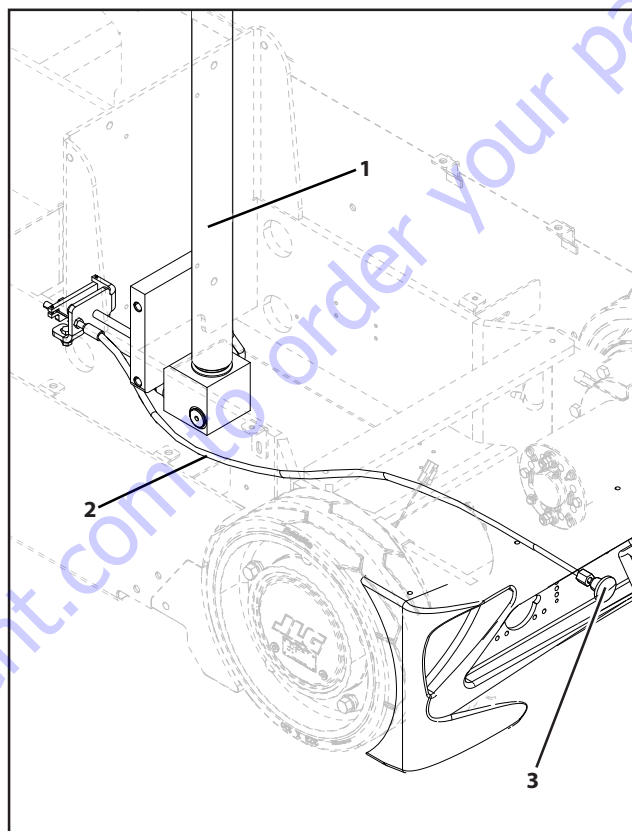

- | |
|--------------------------|
| 1. Lift Cylinder |
| 2. Release Cable |
| 3. External Release Knob |

5.12 MAST ASSEMBLY

All mast section assembly follows a similar procedure:

1. Carefully slide the mast sections together until mast ends are even.

Note: When sliding the mast sections together, be careful not to scratch the anodized surface in the wear pad channels.

2. Assemble the hardware to the bottom of mast section first; then slide this section out the top of previous section and assemble hardware to the top of mast.
3. Always install slide pad shims with slide pads inserted into the slide pad channels, ensuring the ends of mast sections are even.
4. Apply Krytox spray (JLG P/N-3020041) onto the slide pads and slide pad channels before assembly to help mast sections slide easier after slide pads have been properly shimmed.

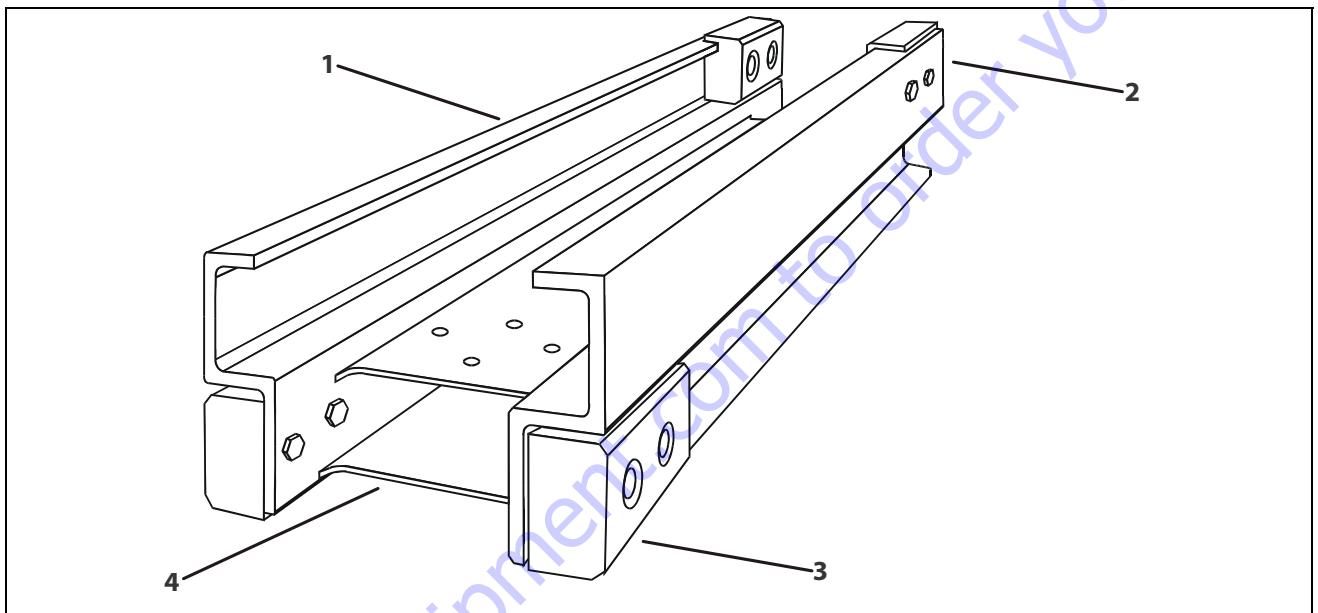

Figure 5-7. Mast Section - Assembly Reference

1 - Open Rail

Refers to open rail front of mast section

2 - Closed Rail

Refers to closed rail back of mast section

3 - Top

Refers to top end of mast section where cover and sheave wheels are attached

4 - Bottom

Refers to bottom end of mast section, which sits in the machine's base frame

Mast Section 1

1. Place mast section 1, rail (open) side up on a clean, flat surface, preferably a table or work bench capable of supporting the weight of the entire mast assembly. (Refer to Figure 5-7.) Slide mast out over end of work surface far enough to allow access to the chain anchor attach hole near the top of the mast.
2. Locate the two single (wide) chain assemblies and attach to the large equalizer anchor plate (if not already attached). Lay out the chain/anchor plate assembly with the anchor plate end towards top of the mast. (Be certain floor surface is clean and free of any metal chips or debris which may stick to lubricated chains.)
3. Insert the chain/anchor plate assembly end into the top of mast section 1 and secure using the large anchor plate attach pin, spacers, and pin keeper.

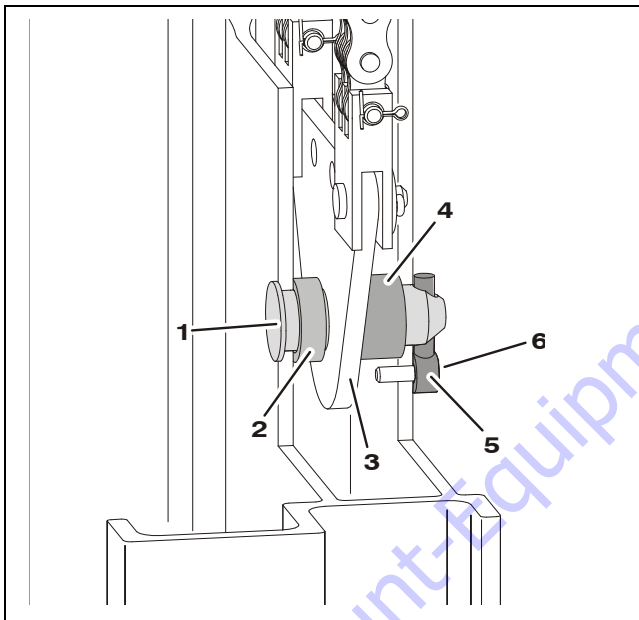

- | | |
|-----------------------------|---------------------|
| 1. Anchor Plate Pin | 4. Long Spacer |
| 2. Short Spacer | 5. Pin Keeper |
| 3. Chain/Anchor Plate Assy. | 6. Keeper Screw (a) |

Note: (a) Apply Loctite #242 to threads.

Mast Section 2

Note: Before sliding mast sections together, spray the slide pad channels with Krytox lubricant spray (JLG P/N- 3020041). Be careful not to scratch or score the anodized finish in the slide pad channels.

1. Locate mast section 2 and carefully slide mast section 2 closed rail into section 1 open rail. Slide sections together until ends are even.
2. Insert slide pads into the slide pad channels at bottom end of mast between sections 1 and 2 (one on each side of the mast) with beveled surface facing out towards section 1.

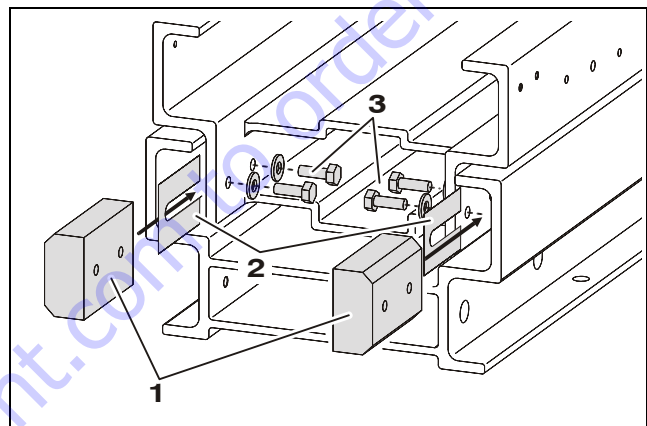

- | | | |
|---------------|---------------|--------------------------------|
| 1. Slide Pads | 2. Shim Stock | 3. Slide Pad Bolts/Washers (a) |
|---------------|---------------|--------------------------------|

Note: (a) Apply Loctite #242 to threads.

3. Place a flat washer under head of each bolt (two 1/4"-20UNC x 3/8" hex head bolts) and thread through holes in mast section 2 inside rails into the slide pad inserts. Thread in enough to hold pad in place.

4. Shim slide pads using the following steps:

Note: Always use the an even amount of shim material behind slide pads on both sides of the mast rails. This will keep mast sections centered in rail channels and prevent any distortion of the mast section.

- a. Start with a 0.036" thick shim and a 0.075" thick shim per side at each slide pad.
 - b. Slide shims into place between slide pad and mast rail. Tighten the slide pad mounting bolts. Be sure there are no air gaps between shims, shim and mast, or shim and slide pad when tightened.
 - c. Check mast section for side play. If play exists add 0.015" shims dividing the thickness equally between both sides of mast. Insert shims until the shims cannot be inserted halfway by hand with the mast pulled to the opposite side.
 - d. When mast slide pads are shimmed properly, there should be no side to side movement of slide pad in rail channel. Mast sections should be snug in channels but still be able to slide in channel by hand.
5. Insert slide pads into the slide pad channels (top of mast) between section 1 and 2 (one on each side of the mast) with beveled surface facing in towards section 2.

Note: Before fastening and shimming the slide pad on the top left side of the mast, install a sequence cable bracket against the mast under the flatwasher.

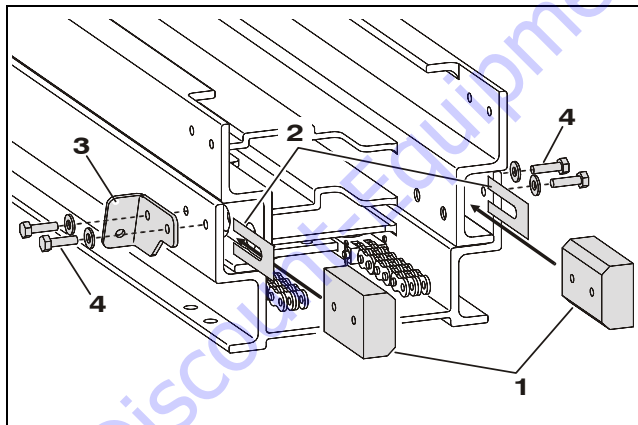

1. Slide Pads
2. Shim Stock
3. Sequence Cable Bracket
4. Slide Pad Bolts/Washers (a)

Note: (a) Apply Loctite #242 to threads.

6. Place a flat washer under head of each bolt (two 1/4"-20UNC x 3/8" hex head bolts) and thread through holes in mast section 1 outside rail (top of mast) and into the slide pad inserts. Thread in enough to hold pad in place.,
7. Repeat step 4 in this section.

8. Before installing the lift cylinder to mast section 1 and into mast section 2, extend the lift cylinder rod out the top of the lift cylinder approximately 1 ft (31 cm).

Note: To extend the hydraulic cylinder, the protective caps on the extend and return ports must be removed. Be careful not to nick or scour rod surface when extending. Catch any oil draining out of cylinder to avoid spillage onto work area. Replace caps when finished.

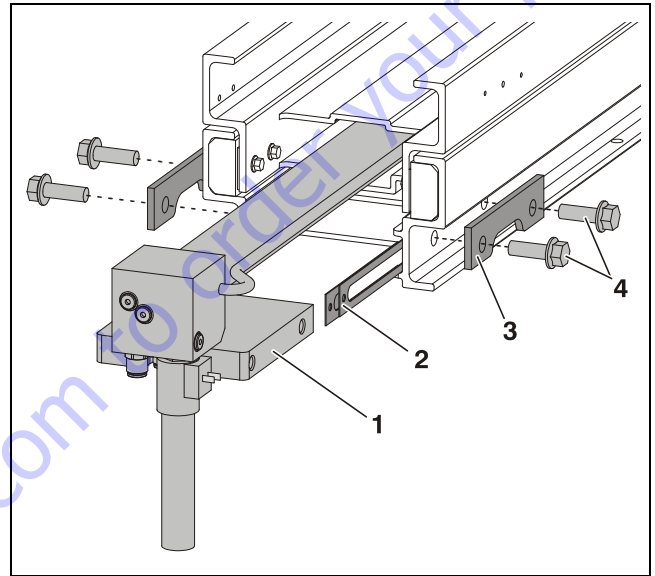

1. Slide Pads
2. Shim Stock
3. Sequence Cable Bracket
4. Slide Pad Bolts/Washers

9. Install the lift cylinder mount into the bottom of mast section 1 and the cylinder into section 2.
10. At the bottom of mast section 1, check for side to side clearance of the cylinder mount. Use mounting shims of equal thickness on each side to center the mount in the closed rail portion, as necessary.
11. Install the mount reinforcement plates and mount bolt and washers. Apply Loctite #242 to threads of mounting bolts before final assembly.

SECTION 5 - MAST COMPONENTS

12. Slide mast section 2 out of mast section 1 approximately one foot.

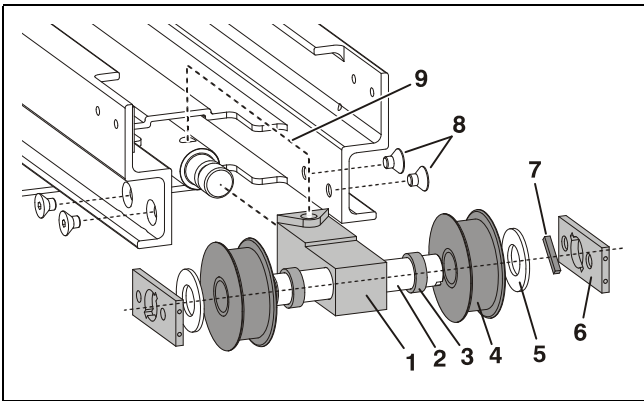

- | | |
|-----------------------------|-----------------------------|
| 1. Anchor Block | 6. Anchor Block |
| 2. Sheave Pin | 7. Sheave Pin |
| 3. Narrow Spacer Tube (a) | 8. Narrow Spacer Tube (a) |
| 4. Sheave Wheels (Wide) (a) | 9. Sheave Wheels (Wide) (a) |
| 5. Thrush Washers (a) | 10. Thrush Washers (a) |

Note: (a) Install one on both sides of anchor block.
(b) Apply Loctite #242 to threads on final assembly.

11. Assemble the chain sheave wheel assembly to the chain assembly anchor block, which will attach to the cylinder rod and to mast section 2, using following steps:
- Insert sheave pin through anchor block assembly.
 - Load one narrow spacer tube onto the sheave pin on each side of the anchor block.
 - Place sheave wheels (for wide #544 chain) on sheave pin, one each side of anchor block.
 - On the outside of each sheave wheel, place a large thrust washer.
 - Insert the key bar into the keyway on the end of the sheave wheel pin.
 - Place a sheave pin support plate on each end of the shaft.
 - Slide the whole anchor block/sheave wheel assembly into top of mast section-2. Slide the anchor block onto the top of the cylinder rod. Check that the hole in the cylinder rod aligns the hole in the anchor block.
 - Align the threaded holes in the sheave pin support bars with the mounting holes on each side of the top of mast section 2 mast. Attach using two 3/8"-16UNC x 1/2" socket head countersunk-flathead cap screws each side. Coat threads with Loctite #171 on final assembly.

12. Locate and assemble the narrow chains set (#444) and attach to the small (triangular shape) chain equalizer anchor plate using the pins, washers and cotter keys.

13. Lay out the chain(#444)/anchor plate assembly with anchor plate end towards mast. (Be certain floor surface is clean and free of any metal chip or debris which may stick to lubricated chains or lay chains in a clean bucket.)
14. Assemble the chain/anchor plate assembly and the chain anchor block to the cylinder rod end using the anchor plate/block attach pin and snap ring.
15. Slide mast section 2 back into section 1 until top and bottom ends are even.

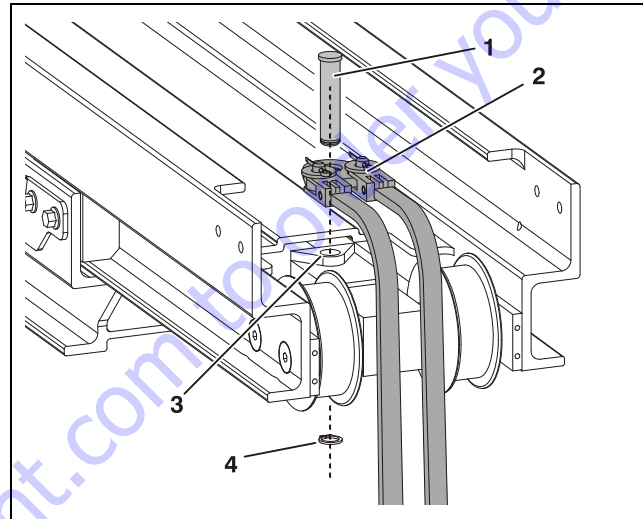

- | | |
|----------------------------|------------------------------|
| 1. Anchor Block Attach Pin | 3. Hole Through Anchor Block |
| 2. Narrow Chain Set | 4. Snap Ring |

Mast Section 3

1. Lay the wide chain set attached to the top of mast section 1 into the open rail on mast section 2.

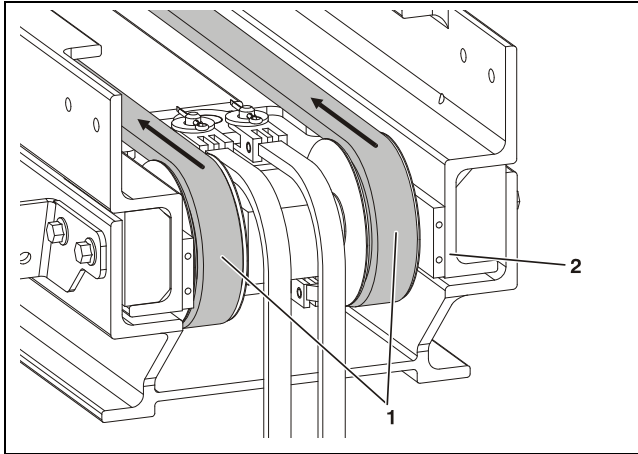

1. Wide Chain Set Attached to Mast Section 1 2. Mast Section 2

Note: Before sliding mast sections together, spray the slide pad channels with Krytox lubricant spray. (JLG P/N- 3020041). Be careful not to scratch or score the anodized finish in the slide pad channels.

2. Carefully slide mast section 3 into section 2 until ends are even.

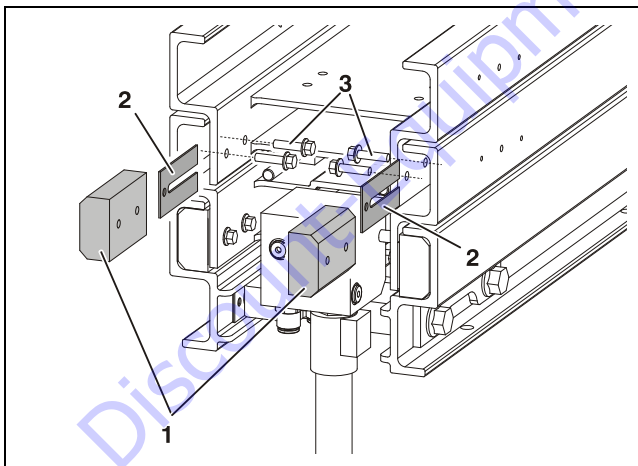

1. Slide Pads 3. Shim Pad Screws
2. Shim Stock

4. At the bottom of mast section 3, install the slide pads between mast section 2. and 3. Shim per instructions in step 4 of Mast Section 2 Assembly.
5. Push mast section 3 out the top of mast section 2 approximately 1 ft (31 cm).

6. Locate the lower chain anchor bracket (one with the threaded attach holes horizontally aligned to outside of bracket).
7. Working at the bottom end of mast section 3, insert the threads (stud) ends of the (wide) chain set, now laying between mast section 2 and 3, into the holes of the lower chain anchor bracket. Loosely thread two 3/8"-16UNC nuts onto the stud threads on each chain.
8. Slide the anchor plate into the closed rail at the bottom of mast section 3 and attach the anchor plate to the bottom of mast section 3 with four 1/4"-20UNC x 3/4" bolts. Apply Loctite #242 to threads on final assembly.

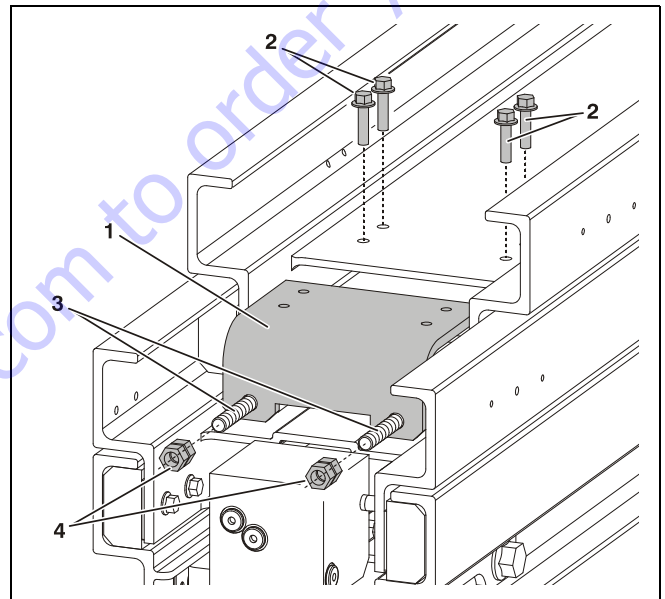

1. Lower Chain Anchor Bracket 3. Wide Chain Set Studs
2. Anchor Bracket Screws 4. Chain Adjust and Jam Nuts

SECTION 5 - MAST COMPONENTS

8. At the top of mast section 3, assemble the chain sheaves (for narrow chain assembly) to top of mast section 3 per the following steps:
 - a. Slide the narrow spacer tube onto one of the remaining sheave pin.
 - b. Place the narrow chain sheave wheel assemblies, one on each side of the narrow spacer, onto the sheave pin.
 - c. Place one wide spacer tube on the outside of each sheave wheel on the sheave pin.
 - d. Insert key into the keyway on the end of sheave pin.
 - e. Place two sheave pin support bars, one each end of sheave pin onto outside of spacer tubes.
 - f. Holding complete sheave wheel assembly, slide assembly into top of mast section 3 and align threaded holes in sheave pin support bars with holes in mast rails.
 - g. Attach to top of mast section 3 using two (2) 3/8"-16UNC x 1/2" long socket head-countersunk-flat-head cap screws, each side. Coat threads with Loctite #171 and tighten.

9. Slide the top of mast section 3 back in even with the top of mast section-2.
10. Insert slide pads into the top end mast rails between section 2 and 3, (one on each side of the mast), with beveled surface facing inward towards section 3.

Note: Before fastening and shimming the slide pad on the top left side of the mast, install a sequence cable bracket against the mast under the flatwasher.

11. Thread slide pad attaching bolts, two 1/4"-20UNC x 3/8" long hex head bolts, place a flat washer under head of each bolt, through holes in outside rail, on top of mast section-2 and into the slide pad inserts. Thread in enough to hold pad in place.
12. Shim per instructions in step 4 of Mast Section 2 Assembly. Apply Loctite #242 to attach screw threads on final assembly.

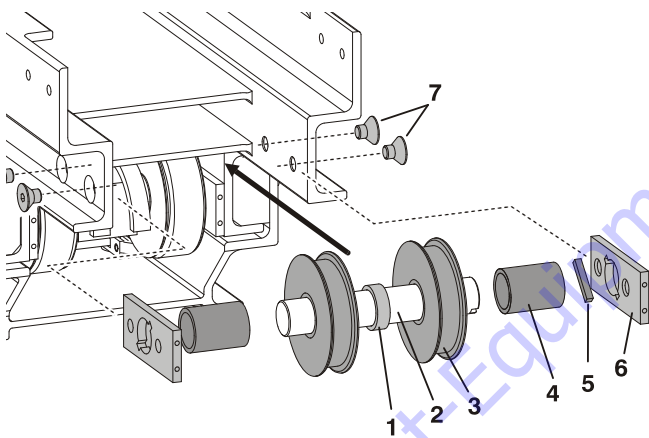

1. Narrow Spacer Tube
2. Sheave Pin
3. Sheave Wheels (Narrow) (a)
4. Wide Spacer Tube (a)
5. Key
6. Sheave Pin Support Plates (a)
7. Support Plate Screws (b)

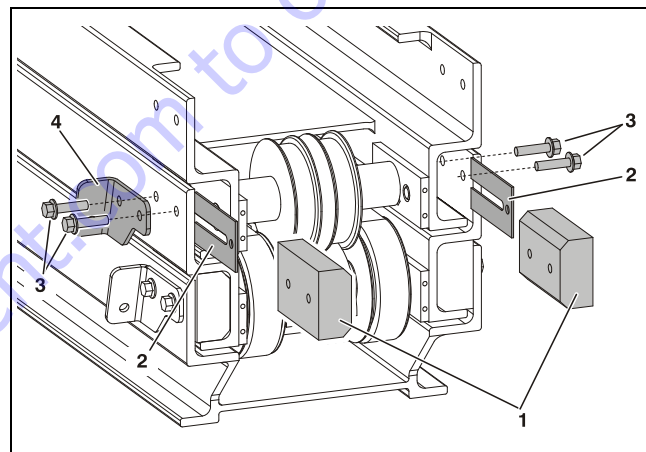

1. Slide Pads
2. Shim Stock
3. Slide Pad Attach Screws (a)
4. Upper Sequence Cable Bracket

Note: (a) Apply Loctite #242 to attach screws on final assembly.

Mast Section 4

1. Lay the narrow chain set attached to the cylinder attach anchor block at the top of mast section 2 into the open rail on mast section 3.

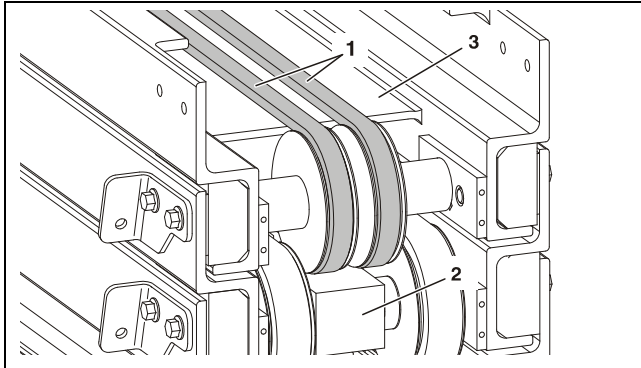

1. Narrow Chain Set Attached to Chain Anchor Block on Mast Section 2 2. Chain Anchor Block
3. Mast Section-3

Note: Before sliding mast sections together, spray the slide pad channels with Krytox lubricant spray, (JLG P/N- 3020041). Be careful not to scratch or score the anodized finish in the slide pad channels.

2. Carefully slide mast section 4 into section 3 until ends are even.
3. At the bottom of mast section 4, install the slide pads between mast section 3 and 4. Shim per instructions in step 4 of Mast Section 2 Assembly. Apply Loctite #242 to the threads of the pad screws on final assembly.

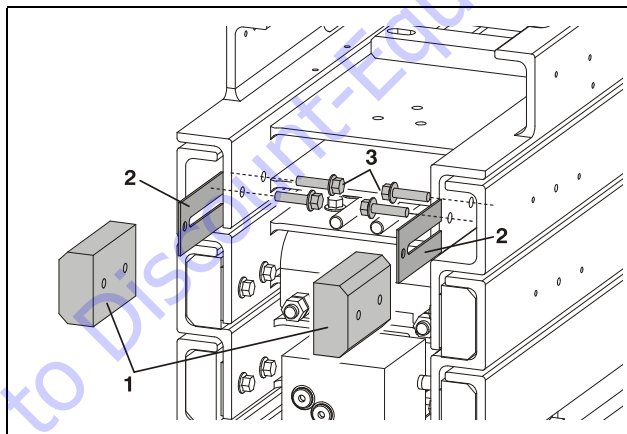

1. Slide Pads 2. Shim Stock
3. Shim Pad Screws (Apply Loctite #242)

4. Slide mast section 4 out the top of mast section 3 approximately 1 ft (31 cm).
5. Locate the lower chain anchor bracket (one with the threaded attach holes in a triangular shape pattern).

6. Working at the bottom end of mast section 4, insert the threads (stud) ends of the (narrow) chain set, now laying between mast section 3 and 4, into the holes of the lower chain anchor bracket. Loosely thread two 3/8"-16UNC nuts onto the stud threads on each chain.
7. Slide the anchor plate into the closed rail at the bottom of mast section 4 and attach the anchor plate to the bottom of mast section 4 with three (3) 1/4"-20UNC x 3/4" long bolts. Apply Loctite #242 to threads on final assembly.

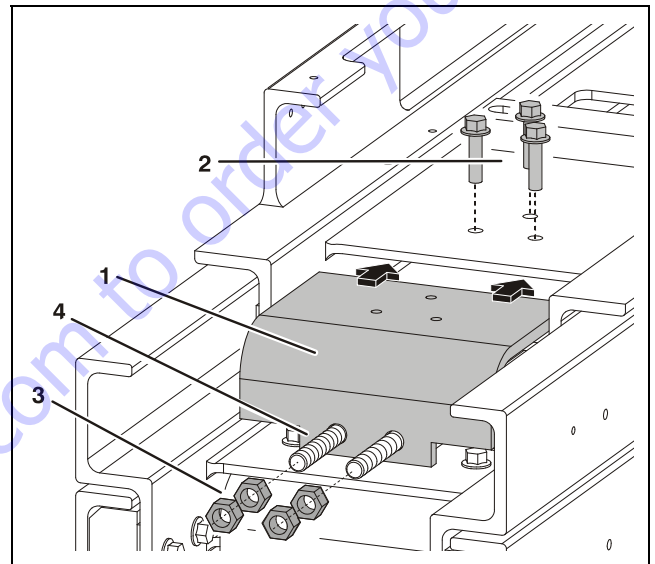

1. Lower Chain Anchor Bracket
2. Anchor Bracket Screws (a)
3. Narrow Chain Set Studs
4. Chain Adjust and Jam Nuts

Note: (a) Apply Loctite #242 to threads on final assembly.

8. Slide the top of mast section 4 back in even with the top of mast section 3.

SECTION 5 - MAST COMPONENTS

9. Insert slide pads into the top end mast rails between section 3 and 4 (one on each side of the mast) with beveled surface facing inward towards section 3.

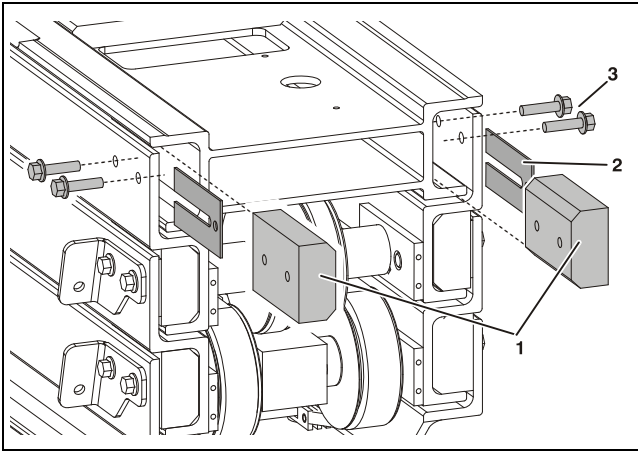

1. Slide Pads
2. Shim Stock
3. Slide Pad Attach Screws (a)

Note: (a) Apply Loctite #242 to attach screws on final assembly.

10. Thread slide pad attaching bolts (two 1/4"-20UNC x 3/8" hex head bolts) through holes in outside rail on top of mast section 2 and into the slide pad inserts. Thread in enough to hold pad in place.
11. Shim per instructions in step 4 of Mast Section 2 Assembly. Apply Loctite #242 to attach screw threads on final assembly.

12. Attach the sequencing cables and hardware to the side of the mast assembly.

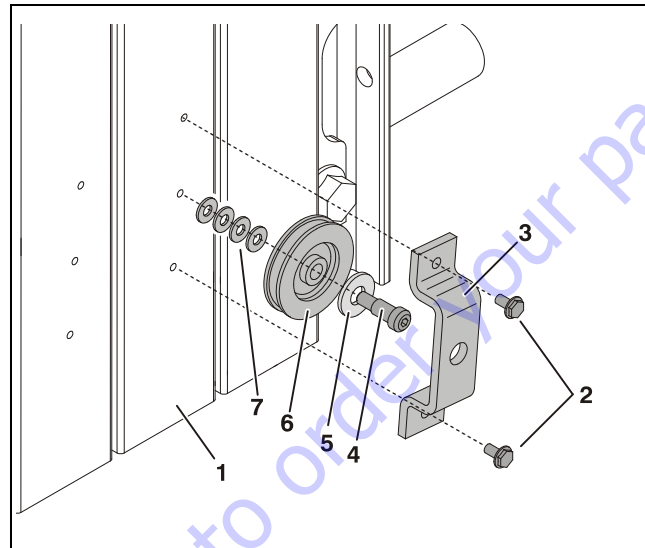

1. Mast Section 2
2. Lower Bracket Attach Screws
3. Lower Bracket
4. Sheave Wheel Attach Bolt
5. Sheave Wheel Thrust Washer
6. Sequence Cable Sheave Wheel
7. Spacers (Qty. 4)

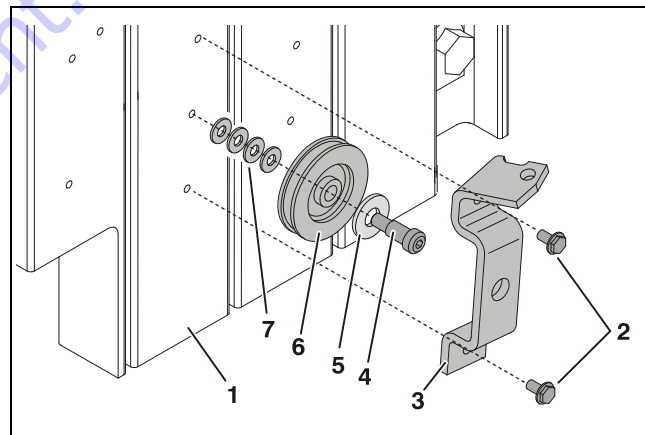

1. Mast Section 3
2. Lower Bracket Attach Screws
3. Lower Bracket
4. Sheave Wheel Attach Bolt
5. Sheave Wheel Thrust Washer
6. Sequence Cable Sheave Wheel
7. Spacers (Qty. 4)

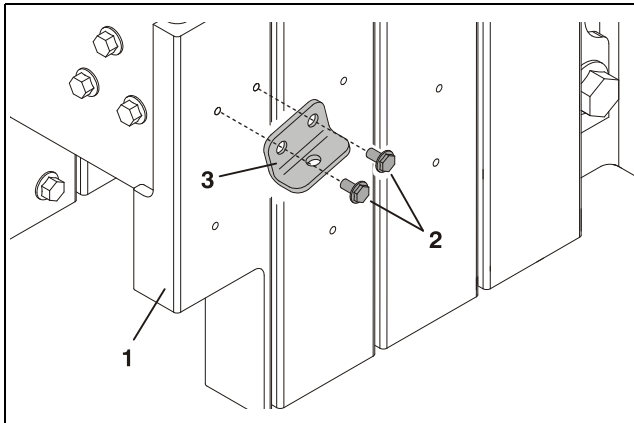

1. Mast Section 4 3. Lower Bracket
2. Bracket Attach Screws

13. Install the platform junction box to ground control station wiring harness (refer to Figure 5-8.), including the platform junction box, powertrack assembly, harness cable sheave assembly, and harness spring tensioner to the side of the mast assembly. Refer to Section 4, Platform Junction Box Install/Remove.

Note: If equipped, re-install the 7 ft height limiting switch and bracket to the mast (See Section 5.4, 7 Foot Height Limit Switch (If Equipped)).

14. The mast assembly is now complete and ready to install onto the base frame.

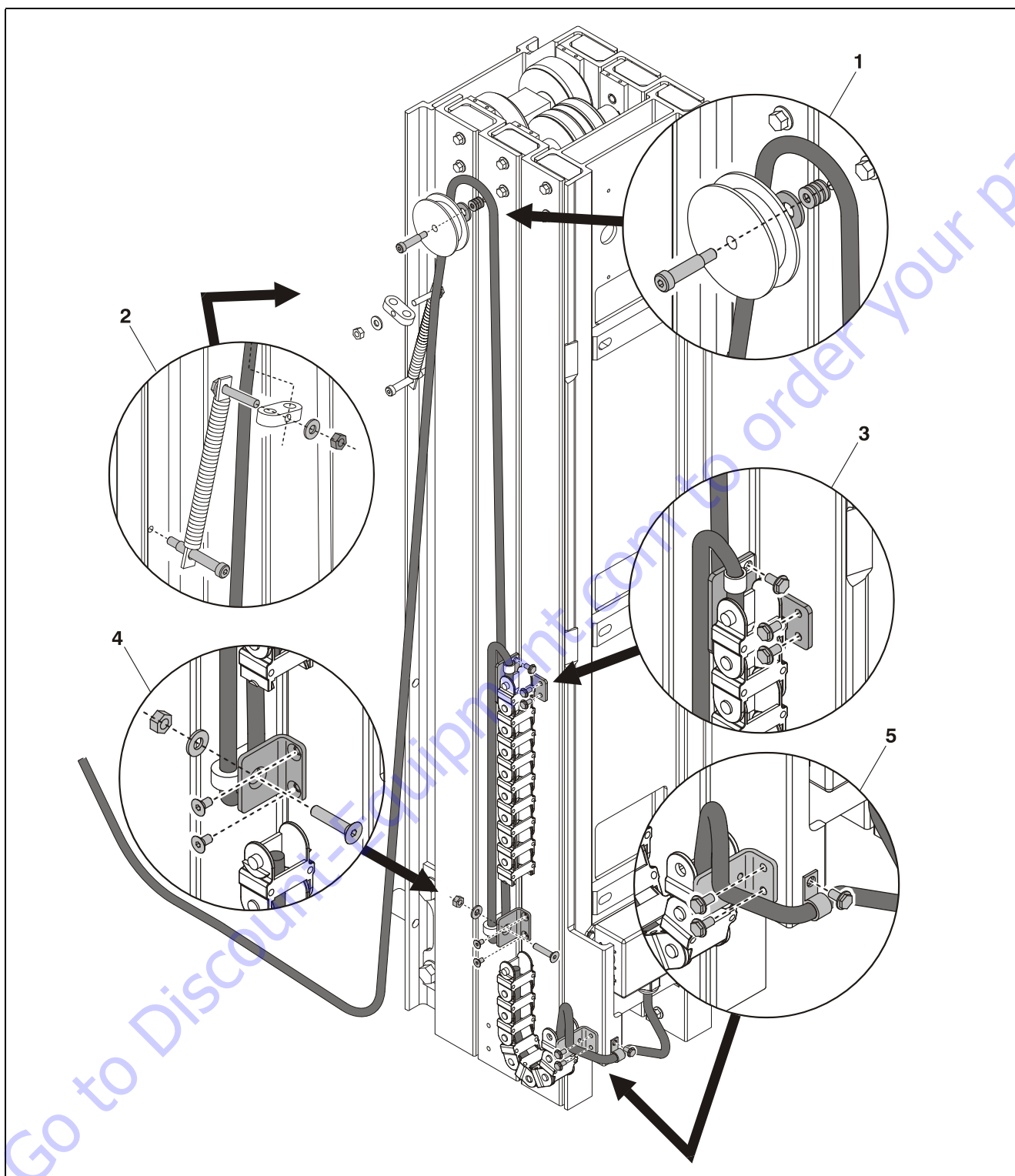

Figure 5-8. Platform Junction Box to Ground Control Station Wiring Harness

- 1. Harness Sheave Wheel
- 2. Harness Spring Tensioner

- 3. Upper Powertrak Bracket
- 4. Mid Powertrak Bracket (Powertrak Shown Cut-away)

- 5. Lower Powertrak Bracket

5.13 MAST CHAINS AND SEQUENCING CABLES ADJUSTMENT

Note: This procedure must be performed with the mast mounted on the machine.

Mast Chain/Cable Adjustment

This procedure will ensure equal load distribution between the individual chains of a mast section chain sets. Refer to Figure 5-9.

1. Remove the mast cover from the platform. (Refer to Section 5.2.)
2. With mast completely lowered, have an operator step into the platform and bounce their weight up and down a few times to ensure platform is at the bottom of travel. Check that the chain sets are seated in their sheaves properly at the top of each mast section.
3. Have the operator exit the platform, then check the side profile of the top of the mast. The mast sections should all be even at the top and not stepped. (Refer to Figure 5-9.)
4. If adjustment is required, adjust one mast section at a time starting from the front of the mast (section 3) and work towards the platform. Only mast section 3 and 4 are adjustable.
5. To adjust, elevate the platform until the chain anchor adjust and jam nuts are accessible at the front and bottom of each mast section.

WARNING

NEVER WORK UNDER AN ELEVATED PLATFORM UNTIL PLATFORM HAS BEEN SAFELY RESTRAINED FROM ANY MOVEMENT BY BLOCKING OR OVERHEAD SLING.

6. Start with the mast section which needs adjustment and loosen the bottom (*jam*) nut on each chain.
7. **Tighten** (to raise mast section), **or loosen** (to lower mast section) **the adjusting nut** against the anchor plate on each chain. Adjust the nut the amount required to raise or lower the top of the mast section to match the side profile shown in Figure 5-7 when the mast is retracted.

Note: It is more important that the studs are equal side to side on a mast section, than it is that the tension in the chains is equal. The chain equalizers will always assure equal tension, but if the adjustment isn't equal as described, the chains may tend to pull to one side or the other. The threaded end of the chain may need to be restrained while tightening the adjust nut to keep the chain from twisting.

8. Fully retract the mast all the way and check if the top of the mast sections appear as shown in Figure 5-9.
9. Repeat steps 1 through 7 for remaining mast sections.

10. Once mast section adjustment is completed, apply Loctite #242 to the threads under the (jam) nuts that were loosened. Then re-tighten the loosened (jam) nuts until tight against the top (adjust) nut. Chain should have slight tension but should not be taut.
11. After all mast adjustments are complete, if necessary readjust the bumpers mounted on the base frame under the platform so the platform rests slightly above the base frame when it is lowered and empty.

Sequencing Cable Adjustment

1. Retract mast completely, and check each sequencing cable on outside of masts for excessive slack. Adjust only to remove slack from cable.
2. Tighten nylock-nut at the sequence cable bracket located at the top of the mast just enough to remove excessive slack from sequencing cable. The springs should not be compressed more than 25% after adjusting.

Note: If slack cannot be adjusted out of the cable and adjust nut has completely compressed the spring, then either the mast side profile is not adjusted properly (even) or the cable will have to be replaced due to stretching.

3. After adjusting the mast chains and sequence cables, cycle mast up and down several times to verify adjustments are correct.

PARTS FINDER

**Search Website
by Part Number**



**Search Manual
Library For Parts
Manual & Lookup Part
Numbers – Purchase
or Request Quote**

Search Manuals

Enter your information to search for manuals and parts.

* Brand:

* Model:

* Serial:

* Part Number:

SEARCH

**Can't Find Part or
Manual? Request Help
by Manufacturer,
Model & Description**

Parts Order Form

Please fill in the following information:

Manufacturer:

Model:

Description:

Quantity:

Part Number:

Part Name:

Part Description:

Part Category:

Part Location:

Part Status:

Part Condition:

Part Material:

Part Color:

Part Weight:

Part Dimensions:

Part Price:

Part Notes:

Submit

Discount-Equipment.com is your online resource for quality parts & equipment.

Florida: **561-964-4949** Outside Florida TOLL FREE: **877-690-3101**

Need parts?

Click on this link: <http://www.discount-equipment.com/category/5443-parts/> and choose one of the options to help get the right parts and equipment you are looking for. Please have the machine model and serial number available in order to help us get you the correct parts. If you don't find the part on the website or on once of the online manuals, please fill out the request form and one of our experienced staff members will get back to you with a quote for the right part that your machine needs.

We sell worldwide for the brands: Genie, Terex, JLG, MultiQuip, Mikasa, Essick, Whiteman, Mayco, Toro Stone, Diamond Products, Generac Magnum, Airman, Haulotte, Barreto, Power Blanket, Nifty Lift, Atlas Copco, Chicago Pneumatic, Allmand, Miller Curber, Skyjack, Lull, Skytrak, Tsurumi, Husquvarna Target, , Stow, Wacker, Sakai, Mi-T- M, Sullair, Basic, Dynapac, MBW, Weber, Bartell, Bennar Newman, Haulotte, Ditch Runner, Menegotti, Morrison, Contec, Buddy, Crown, Edco, Wyco, Bomag, Laymor, Barreto, EZ Trench, Bil-Jax, F.S. Curtis, Gehl Pavers, Heli, Honda, ICS/PowerGrit, IHI, Partner, Imer, Clipper, MMD, Koshin, Rice, CH&E, General Equipment, ,AMida, Coleman, NAC, Gradall, Square Shooter, Kent, Stanley, Tamco, Toku, Hatz, Kohler, Robin, Wisconsin, Northrock, Oztec, Toker TK, Rol-Air, Small Line, Wanco, Yanmar

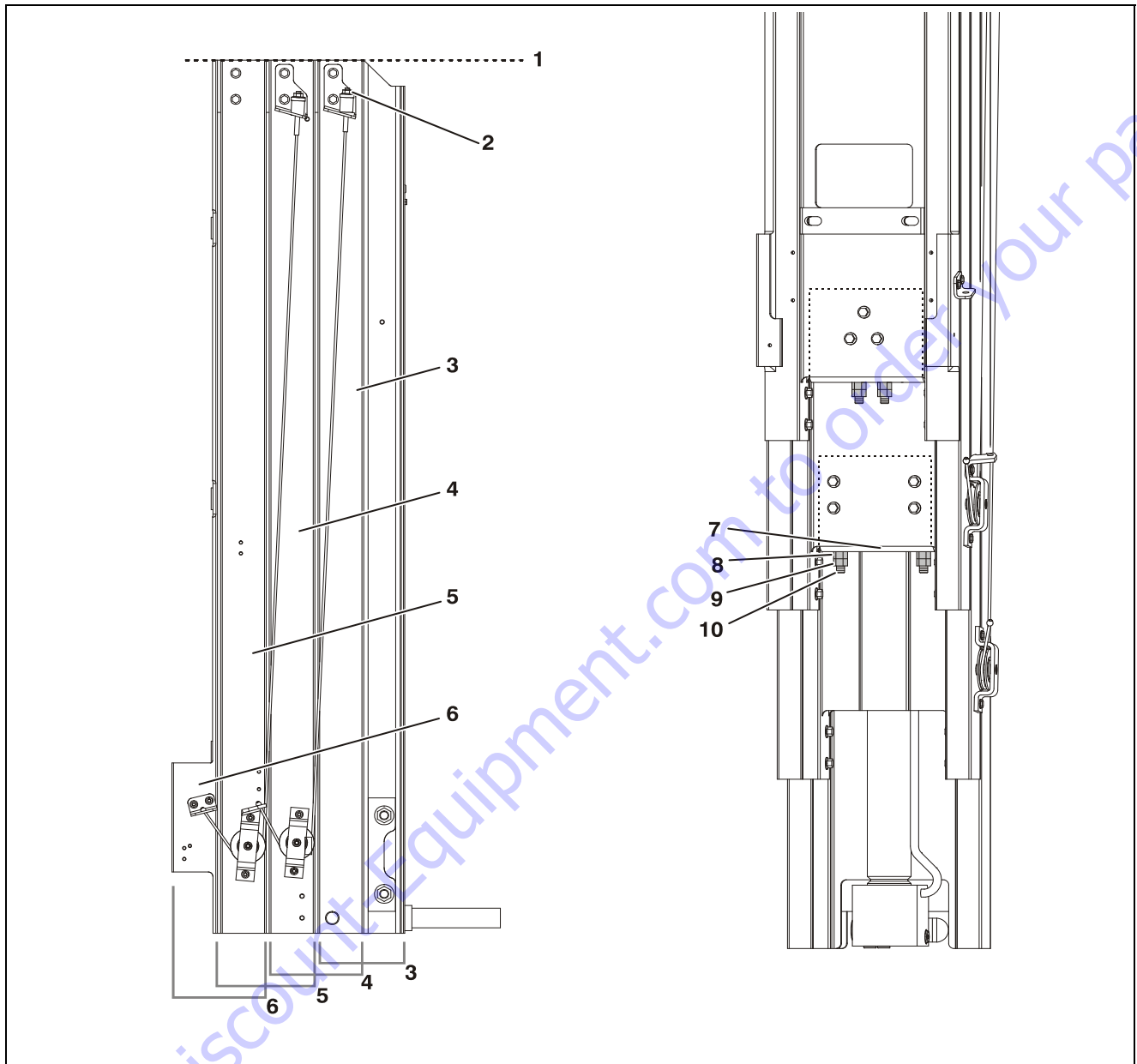

Figure 5-9. Mast Chain and Sequence Cable Adjustment Components

- | | | | |
|--|-------------------|--------------------------------|-------------------------------|
| 1. Mast Side Profile -
(Sections Even at Top) | 3. Mast Section 1 | 6. Mast Section 4 | 9. Chain Lock (Jam) Nut |
| 2. Sequence Cable Adjust Nut | 4. Mast Section 2 | 7. Chain Anchor Plate (Inside) | 10. Threaded Chain End (Stud) |
| | 5. Mast Section 3 | 8. Chain Adjust Nut | |

SECTION 6. TROUBLESHOOTING

6.1 GENERAL

This section contains troubleshooting information to be used for locating and correcting most operating problems. If a problem should develop which is not presented in this section or which is not corrected by listed corrective actions, technically qualified guidance should be obtained before proceeding with any maintenance.

NOTICE

IT IS GOOD PRACTICE TO AVOID PRESSURE-WASHING ELECTRICAL/ELECTRONIC COMPONENTS. IN THE EVENT PRESSURE-WASHING THE MACHINE IS NEEDED, ENSURE THE MACHINE IS SHUT DOWN BEFORE PRESSURE-WASHING. SHOULD PRESSURE WASHING BE UTILIZED TO WASH AREAS CONTAINING ELECTRICAL/ELECTRONIC COMPONENTS, JLG INDUSTRIES, INC. RECOMMENDS A MAXIMUM PRESSURE OF 750 PSI (52 BAR) AT A MINIMUM DISTANCE OF 12 INCHES (30.5 CM) AWAY FROM THESE COMPONENTS. IF ELECTRICAL/ELECTRONIC COMPONENTS ARE SPRAYED, SPRAYING MUST NOT BE DIRECT AND BE FOR BRIEF TIME PERIODS TO AVOID HEAVY SATURATION.

6.2 TROUBLESHOOTING INFORMATION

Troubleshooting procedures applicable to this machine are listed and defined starting with Section 6.8 in this section of the manual.

Each malfunction within an individual group or system is followed by a listing of probable causes which will enable determination of the applicable remedial action. The probable causes and the remedial action should, where possible, be checked in the order listed in the troubleshooting tables.

It should be noted that there is no substitute for a thorough knowledge of the equipment and related systems.

It should be recognized that the majority of the problems arising in the machine will be centered in the hydraulic and electrical systems. For this reason, every effort has been made to ensure that all likely problems in these areas are given the fullest possible treatment. In the remaining machine groups, only those problems which are symptomatic of greater problems which have more than one probable cause and remedy are included. This means that problems for which the probable cause and remedy may be immediately obvious are not listed in this section.

The first rule for troubleshooting any circuit that is hydraulically operated and electrically controlled is to determine if the circuit is lacking hydraulic oil and electrical control power. This can be ascertained by overriding the bypass valve (mechanically or electrically) so that oil is available to the function valve, then overriding the function valve mechanically. If the function performs satisfactorily, the problem exists with the control circuit.

6.3 HYDRAULIC CIRCUIT CHECKS

The first reference for improper function of a hydraulic system, where the cause is not immediately apparent, should be the Hydraulic Diagram Circuit. The best place to begin the problem analysis is at the power source (pump). Once it is determined that the pump is serviceable, then a systematic check of the circuit components, would follow.

NOTE: For aid in troubleshooting hydraulic circuits, refer to Figure 6-17.

6.4 ELECTRICAL CIRCUIT CHECKS

General

The drive system on the 10MSP machines requires a microprocessor controlled electrical circuit to operate smoothly and accurately. All platform control console functions are relayed to various machine components (i.e. platform up/down, drive functions, etc.) through the Ground Control Module microprocessor box (mounted under the front hood). The Ground Control Module is pre-programmed with factory pre-set personality settings for each machine function.

To help diagnose any problems with components plugged into the Ground Control Module, the module is designed with an internal fault code and text messaging system displayed on an LCD screen at the module. The platform control console also will display LED Flash Codes using the Battery Charge/LED strip on the console. When operating normally the LED panel on the platform control console indicates the battery voltage status using ten LEDs (red/yellow/green). If a malfunction to the machine's electrical components occurs, the platform console LED's will flash a number of LEDs to help indicate the problem to the Operator in the platform. The Fault Codes and LED Flash Codes are outlined in the following sub-sections of this chapter.

NOTE: For aid in troubleshooting electrical problem, refer to the appropriate electrical schematic at the end of this section.

6.5 MULTIMETER BASICS

A wide variety of multimeters or Volt Ohm Meters (VOM) can be used for troubleshooting equipment. A digital meter with reasonable accuracy (within 7%) is recommended for the measurements in these procedures. This section shows diagrams of a common, digital VOM configured for several different circuit measurements. Instructions for VOM may vary. Please consult the meter operator's manual for more information.

Grounding

"Grounding the meter" means to take the black lead (which is connected to the COM (common) or negative port) and touch it to a good path to the negative side of the voltage source.

Backprobing

To "backprobe" means to take the measurement by accessing a connector's contact on the same side as the wires, the back of the connector. Readings can be done while maintaining circuit continuity this way. If the connector is the sealed type, great care must be taken to avoid damaging the seal around the wire. It is best to use probes or probe tips specifically designed for this technique, especially on sealed connectors. Whenever possible insert probes into the side of the connector such that the test also checks both terminals of the connection. It is possible to inspect a connection within a closed connector by backprobing both sides of a connector terminal and measuring resistance. Do this after giving each wire a gentle pull to ensure the wires are still attached to the contact and contacts are seated in the connector.

Min/Max

Use of the "Min/Max" recording feature of some meters can help when taking measurements of intermittent conditions while alone. For example, you can read the voltage applied to a solenoid when it is only operational while a switch, far from the solenoid and meter, is held down.

Polarity

Finding a negative voltage or current reading when expecting a positive reading frequently means the leads are reversed. Check what reading is expected, the location of the signal and that the leads are connected to the device under test correctly. Also check that the lead on the "COM" port goes to the ground or negative side of the signal and the lead on the other port goes to the positive side of the signal.

Scale

M = Mega = 1,000,000 * (Displayed Number)

k = kilo = 1,000 * (Displayed Number)

m = milli = (Displayed Number) / 1,000

μ = micro = (Displayed Number) / 1,000,000

Example: 1.2 k Ω = 1200 Ω

Example: 50 mA = 0.05 A

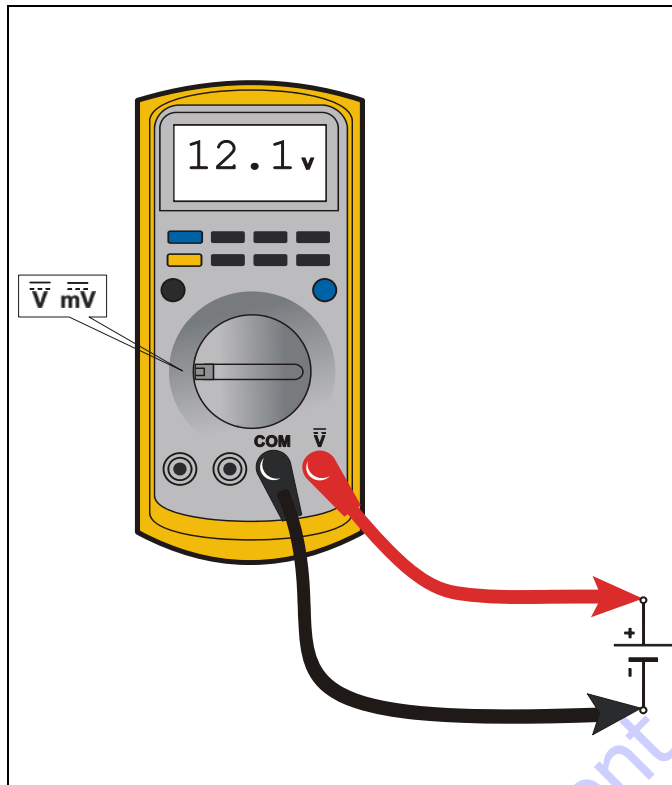
Voltage Measurement**Figure 6-1. Voltage Measurement (DC)**

- If meter is not auto ranging, set it to the correct range (see multimeter's operation manual)
- Use firm contact with meter leads

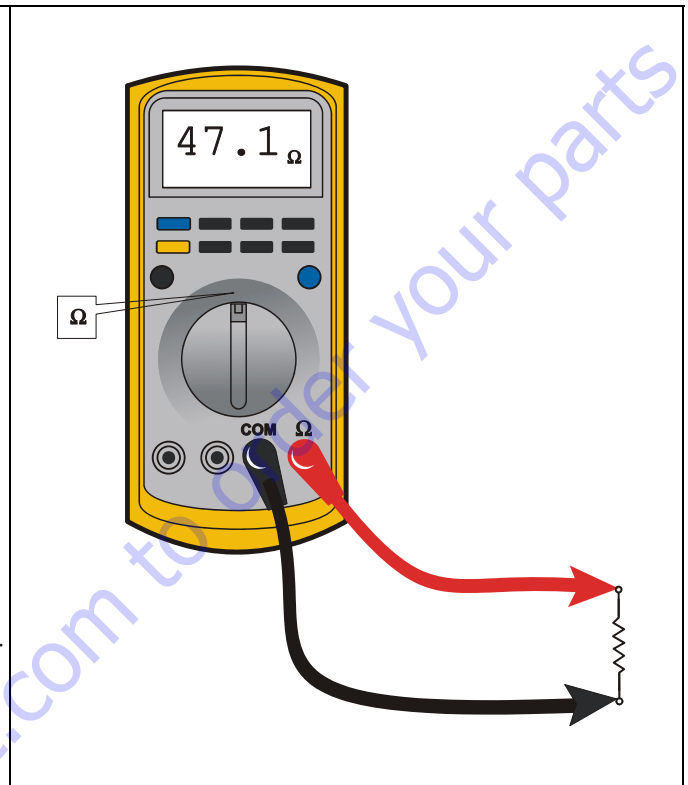
Resistance Measurement**Figure 6-2. Resistance Measurement**

- First test meter and leads by touching leads together. Resistance should read a short circuit (very low resistance)
- Circuit power must be turned OFF before testing resistance
- Disconnect component from circuit before testing
- If meter is not auto ranging, set it to the correct range (See multimeter's operation manual)
- Use firm contact with meter leads

Continuity Measurement

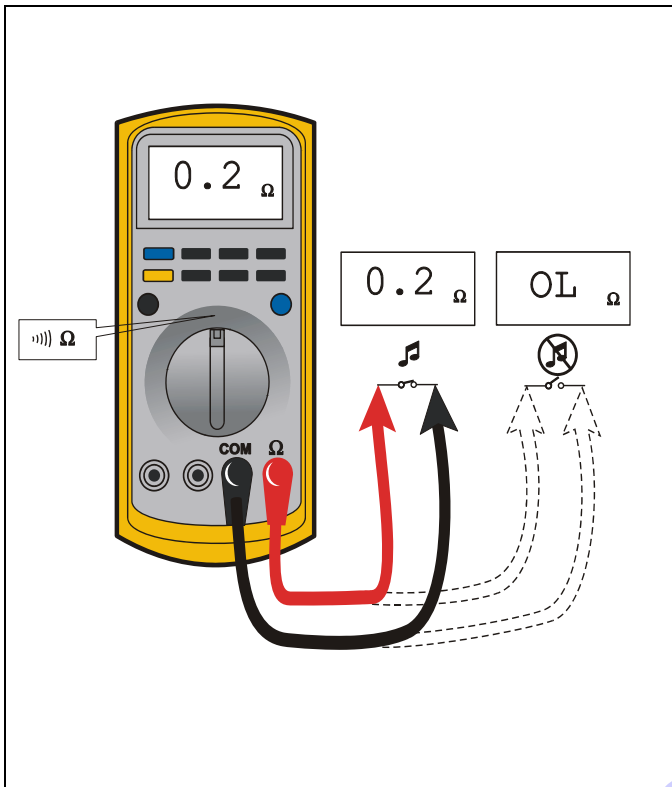

Figure 6-3. Continuity Measurement

- Some meters require a separate button press to enable audible continuity testing
- Circuit power must be turned OFF before testing continuity
- Disconnect component from circuit before testing
- Use firm contact with meter leads
- First test meter and leads by touching leads together. Meter should produce an audible alarm, indicating continuity

Current Measurement

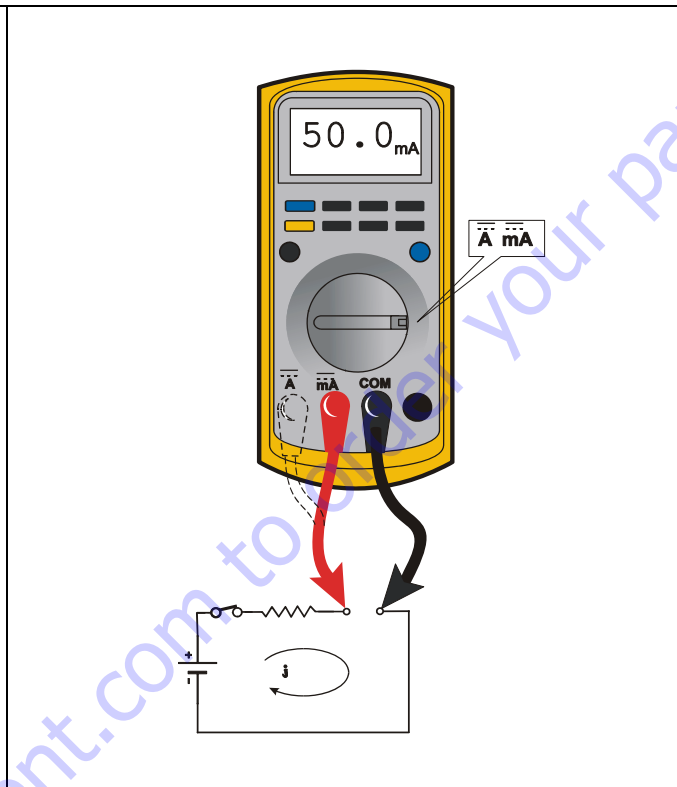

Figure 6-4. Current Measurement (DC)

- Set up the meter for the expected current range
- Be sure to connect the meter leads to the correct jacks for the current range you have selected
- If meter is not auto ranging, set it to the correct range (See multi meter's operation manual)
- Use firm contact with meter leads

Continuity Measurement Over Long Distances

When trying to determine continuity of a harness or wire, longer than the reach of standard instrument leads, is possible to perform the check without excessively long leads. Using the other wires in the harness one can determine the condition of a particular wire in the harness.

Requirements

- Harness with at least three separate wires including the wire under test.
- These wires must be able to be isolated from other wires, etc.
- Jumper or method to connect contacts on one side of harness.
- Meter that can measure resistance or continuity.

Procedure

Test multimeter leads resistance. Subtract this value from the measured resistance of the wires to get a more accurate measurement.

Consult the circuit schematic to determine which wires to use in addition to wire under test, here called wire #1 and wire #2, and how to isolate these wires. These wires should appear in the same connectors as the wire under test or are within reach of the jumper.

1. Disconnect all connections associated with the wire under test and the two additional wires. If harness is not completely isolated disconnect battery terminals also, as a precaution.
2. Measure continuity between all three wires, the wire under test, wire #1 and wire #2. These should be open. If not, repair the shorted wires or replace the harness.
3. On one side, jumper from contact of wire #1 and wire #2.
4. Measure continuity between wire #1 and wire #2. If there is continuity, both wires are good and can be used for this test. If there is not continuity, either wire could be bad. Check connections and measurement setup. Redo measurement. If still no continuity, repair wires or consult schematic for other wires to use for test.
5. Jumper from wire under test to wire #1.
6. Measure continuity. If there is continuity, the wire under test is good. Resistance of a wire increases as the length increases and as the diameter decreases.

One can find the continuity of two wires, here #1 and #2, at once by following steps 1 through 4. If there is a problem the third wire is used to troubleshoot the other wires. To find the problem, start at step 1 and use the entire procedure.

6.6 ELECTRICAL SWITCH TESTING

Basic Check

The following check determines if the switch is functioning properly, not the circuit in which the switch is placed. A switch is functioning properly when there is continuity between the correct terminals or contacts only when selected.

1. De-energize the circuit.
2. Isolate the switch from the rest of the circuit if possible. If not possible, keep in mind it may affect readings.
3. Access the terminals to the switch.
4. If the switch has two terminals:
 - a. Measure resistance across the terminals.
 - b. Change the switch position.
 - c. Measure resistance again with the leads in the same positions. If the meter was reading short, it should read an open. If the meter was reading open it should read short.
5. If the switch has more than two terminals, consult the schematic or switch diagram to determine what terminals will be connected. The test is similar to testing a switch with two terminals.
 - a. Place one meter lead on the common contact and the other on a different contact in the same circuit.
 - b. Cycle through all positions of the switch. The meter should read short only when the switch connects the two terminals and open otherwise.
 - c. If the switch has more than one common contact repeat the process for that circuit.

Limit Switches

Limit switches are used to control movement or indicate position. Mechanical limit switches are just like manually operated switches except that the moving object operates the switch. These switches can be tested the same way as a standard switch by manually operating the sensing arm.

Another type of limit switch used by JLG is the inductive proximity switch, also referred to as a "prox switch". Inductive proximity switches are actuated only by ferrous metal (metal that contains Iron, such as steel) near the switch. They do not require contact, and must be energized to actuate. These types of switches can be used to detect boom or platform position, for example. These switches have a sensing face where the switch can detect ferrous metal close to it. To find the sensing face, take note how the switch is mounted and how the mechanisms meet the switch. Test this type of switch as follows:

1. Remove prox switch from its mount.
2. Reconnect harness if it was disconnected for step 1, and turn on machine.
3. Hold switch away from metal and observe switch state in the control system diagnostics using the Analyzer. See vehicle or control system documentation on how to do this.
4. Place sensing face of switch on the object to be sensed by the switch. If that is not available, use a piece of ferrous metal physically similar to it. The switch state in the control system diagnostics should change.
5. When reinstalling or replacing switch be sure to follow mounting instructions and properly set the gap between the switch and object sensed.

Automatic Switches

If the switch is actuated automatically, by temperature or pressure for example, find a way to manually actuate the switch to test it. Do this either by applying heat or pressure, for example, to the switch. These switches may need to be energized to actuate.

1. Connect instrumentation to monitor and/or control the parameter the switch is measuring.
2. Observe switch state in control system with the Analyzer. See vehicle or control system documentation on how to do this.
3. Operate system such that the switch actuates. This could be going over a certain pressure or temperature, for example. The state indicated in the control system should change.

Switch Wiring - Low Side, High Side

When controlling a load, a switch can be wired between the positive side of the power source and the load. This switch is called a "high side" switch. The switch supplies the power to the load. When a switch is wired between the negative side of the power source and the load, it is a "low side" switch. The switch provides the ground to the load.

A low side switch will allow voltage to be present on the load. No power is applied because the switch is stopping current flow. This voltage can be seen if the measurement is taken with one test lead on the load and the other on the battery negative side or grounded to the vehicle. What is actually being measured is the voltage drop across the switch. This could mislead a technician into thinking the load is receiving power but not operating. To produce an accurate picture of power or voltage applied to the load, measure voltage across the load's power terminals. Also, the technician can measure the voltage at both power terminals with respect to battery ground. The difference between those two measurements is the voltage applied to the load.

6.7 GROUND CONTROL MODULE LCD DISPLAY

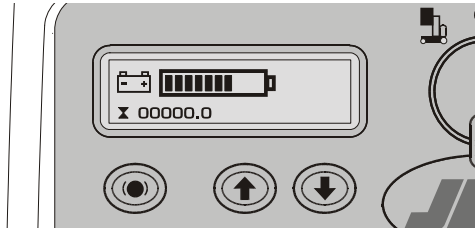

At power-up and during operation the LCD display on the Ground Control Module displays the current machine operating status. The following illustration explains the symbol indications.

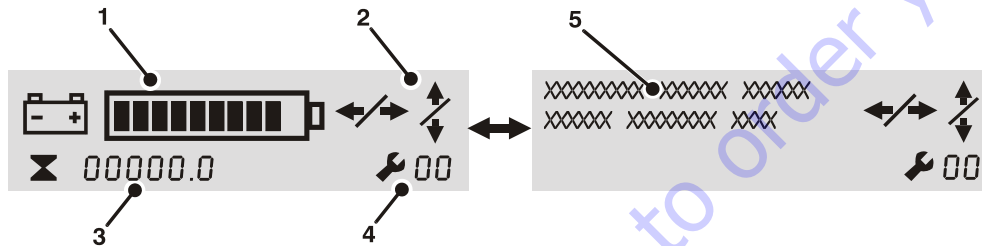
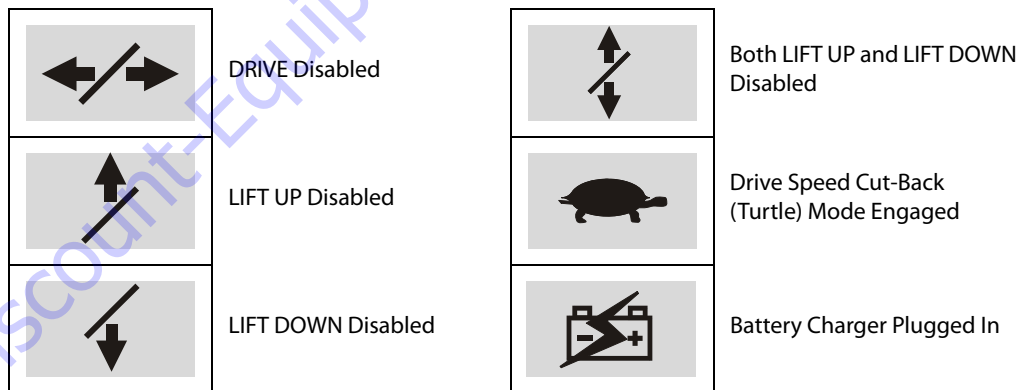

Figure 6-5. LCD Display Symbols

- 1. Battery Charge Indicator (BCI)
- 2. Function Display or Function Disable Indicators
- 3. Hour Meter Display
- 4. Fault Code Indicator
- 5. Fault Code Text Message Display (a)

NOTE: (a) When an Fault code is indicated the LCD screen will alternate between the text and symbol display modes.

In the LCD Display Symbols illustration item 2 above, the Function Display or Function Disable Indicators will vary as shown:



SECTION 6 - TROUBLESHOOTING

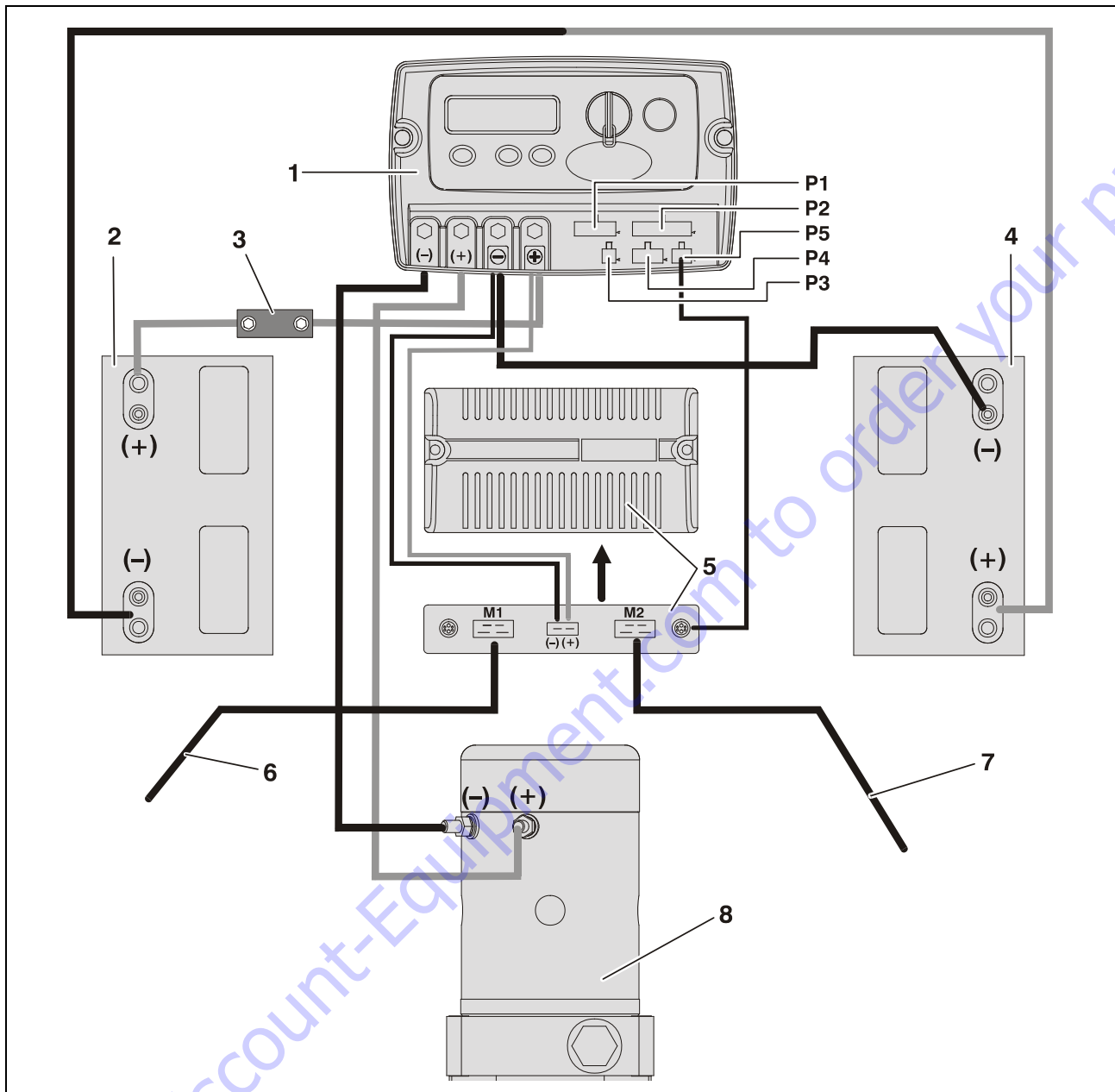

- | | | |
|------------------------------|--|---|
| 1. Ground Control Module (a) | 4. Right Side Battery (b) | 7. Power Cable To Right Drive Motor/Brake (a) |
| 2. Left Side Battery (b) (c) | 5. Traction Control Module (a) | 8. Hydraulic Pump/Motor/Tank Assembly (b) |
| 3. 175 Amp Fuse | 6. Power Cable To Left Drive Motor/Brake (a) | |

Ground Control
Module Plugs:

- P1 - Horn, Alarm, Beacons, Lift Down Valve Harness (a)
- P2 - Elevation/Speed, Charger Limit Switch Harness (a)
- P3 - Programmable Security Lock Harness (Option) (a)

- P4 - Platform Joystick Harness (a)
- P5 - Joystick Protocol Harness to Traction Control Module (a)

NOTES: (a) Apply di-electric grease JLG Part Number 3020038 to wiring harness terminals, to prevent moisture from entering module.
 (b) Seal NEG (-) and POS (+) posts with battery grease to prevent corrosion.
 (c) An quick-disconnect is installed on the left battery (+) POSITIVE cable for easier power disconnect when servicing machine.

Figure 6-6. Component Electrical Connections with 2-12V Batteries (Prior to SN 0130032507)

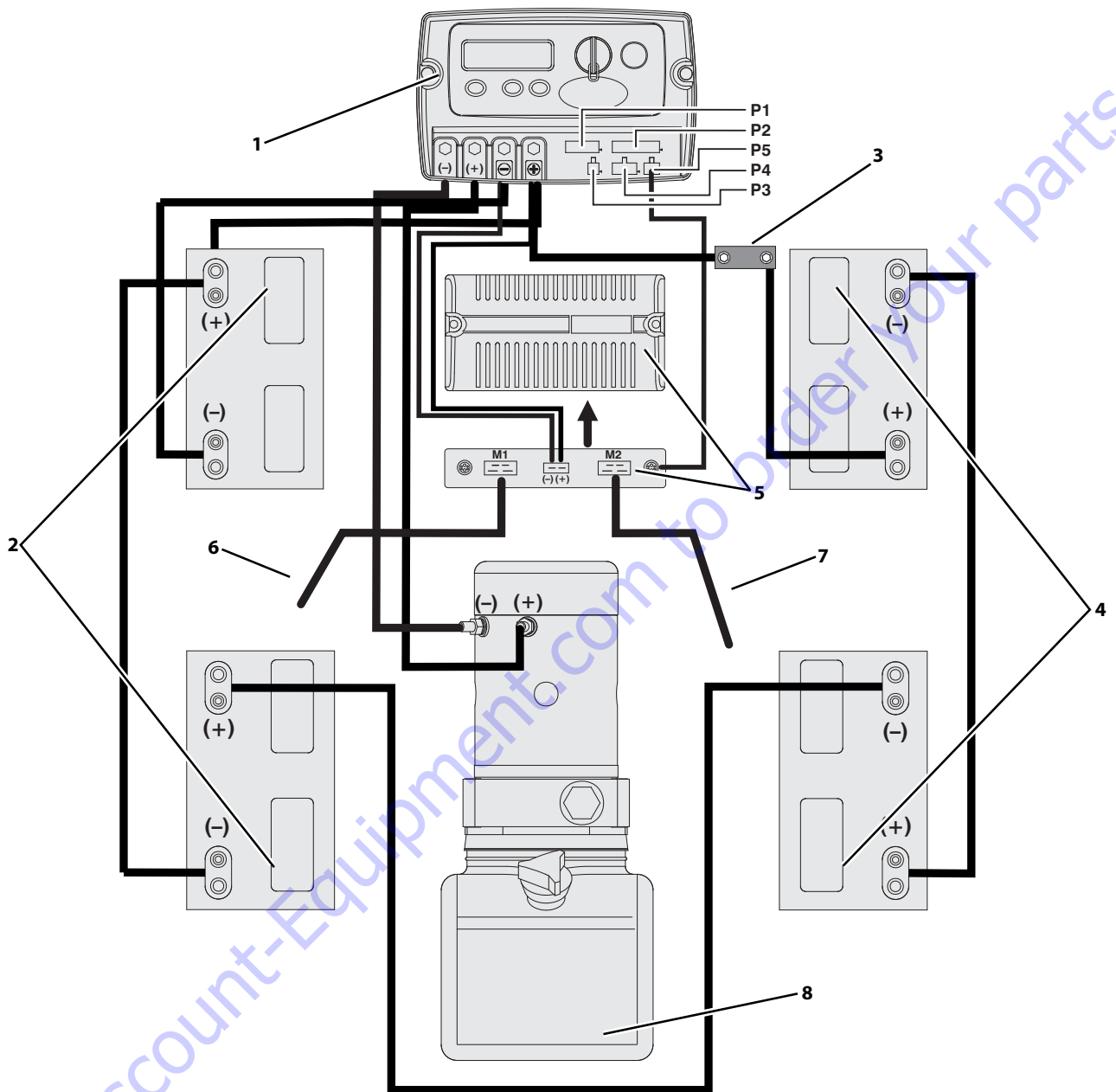

- 1. Ground Control Module (a)
- 2. Left Side Battery (b) (c)
- 3. 175 Amp Fuse
- 4. Right Side Battery (b)
- 5. Traction Control Module (a)
- 6. Power Cable To Left Drive Motor/Brake (a)
- 7. Power Cable To Right Drive Motor/Brake (a)
- 8. Hydraulic Pump/Motor/Tank Assembly (b)

Ground Control
Module Plugs:

P1 - Horn, Alarm, Beacons, Lift Down Valve Harness (a)
P2 - Elevation/Speed, Charger Limit Switch Harness (a)
P3 - Programmable Security Lock Harness (Option) (a)

P4 - Platform Joystick Harness (a)
P5 - Joystick Protocol Harness to Traction Control
 Module (a)

NOTES: (a) Apply di-electric grease JLG Part Number 3020038 to wiring harness terminals, to prevent moisture from entering module.
 (b) Seal NEG (-) and POS (+) posts with battery grease to prevent corrosion.
 (c) An quick-disconnect is installed on the left battery (+) POSITIVE cable for easier power disconnect when servicing machine.

Figure 6-7. Component Electrical Connections with 4-6V Batteries (SN 0130032507 to Present)

SECTION 6 - TROUBLESHOOTING

Table 6-1. LCD Display - Service Fault Code Conditions

FAULT CODE	PLATFORM CONSOLE LEDs FLASHING	LCD SYMBOL SCREEN	LCD TEXT SCREEN	FAULT DESCRIPTION/ MACHINE CONDITION	TROUBLESHOOTING
—	—		—	Machine In Drive Speed Cut-Back (Turtle) Mode All The Time	See Table 6-5
—	5		Obstruction Below Platform	>20lb Detected on Object Sensing Pad	See Table 6-6
—	—		BRAKES RELEASED	Brakes Released DRIVE Disabled	Engage Brakes - Press Brake Release Button on Ground Control Station
—	—		—	Charger AC Plugged In DRIVE Disabled	Unplug Charger AC Input Power Cord from Machine
—	—		ENTER SECURITY CODE	Programmable Security Lock Password	Type in Code At PSL Key Pad See Operators Manual for Proper Operation
01	1		LOW BATTERY VOLTAGE	Low Battery Voltage	See Table 6-7
02	2	RESERVED		RESERVED	
03	2	RESERVED		RESERVED	
04	3		TILTED	Tilt Condition (Platform Elevated) DRIVE and Lift UP Disabled	See Table 6-8
05	—	Obstruction Sensor - No Communication		No Communication with OSS	See
06	8			Drive Motor Brush Wear Warning (Counts down 25 hr of DRIVE operation to a 10 sec shut down mode)	Drive Motor Brushes Require Service Replacement (See Section 3.5 for further instructions)
07	6		LEFT MOTOR DISCONNECTED	Left Drive Motor Disconnected DRIVE Disabled	See Table 6-10
08	6		RIGHT MOTOR DISCONNECTED	Right Drive Motor Disconnected DRIVE Disabled	See Table 6-11

Table 6-1. LCD Display - Service Fault Code Conditions

FAULT CODE	PLATFORM CONSOLE LEDs FLASHING	LCD SYMBOL SCREEN	LCD TEXT SCREEN	FAULT DESCRIPTION/MACHINE CONDITION	FOR TROUBLESHOOTING REFER TO
09	6			Left Brake Disconnected DRIVE, Lift UP/DOWN Disabled	See Table 6-12
10	6			Right Brake Disconnected DRIVE, Lift UP/DOWN Disabled	See Table 6-13
11	6			Left Drive Motor Short Circuit DRIVE Disabled	See Table 6-14
12	6			Right Drive Motor Short Circuit DRIVE Disabled	See Table 6-15
13	6			Traction Module In Fold Back DRIVE Disabled	See Table 6-16
14	7			Pump Motor Disconnected Lift UP Disabled	See Table 6-17
15	7			Lift Down Valve Disconnected Lift UP/DOWN Disabled	See Table 6-18
16	7			Down Valve or Down Valve Circuit Short Lift UP/DOWN Disabled	See Table 6-19
17	7			Ground Control Module In Fold Back (Machine Stopped)	See Table 6-20
18	—			Alarm or Alarm Circuit Short	See Table 6-21
19	—			Alarm Disconnected	See Table 6-22
20	—			Beacon or Beacon Circuit Short	See Table 6-23
21	—			Beacon Disconnected	See Table 6-24

SECTION 6 - TROUBLESHOOTING

Table 6-1. LCD Display - Service Fault Code Conditions











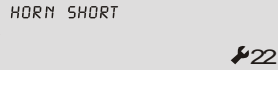



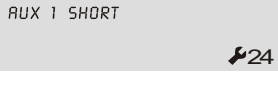
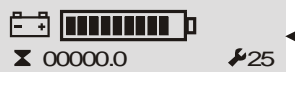

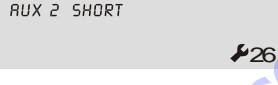



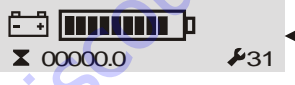

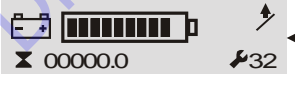
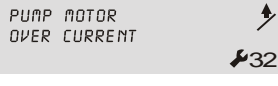

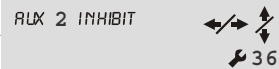

FAULT CODE	PLATFORM CONSOLE LEDs FLASHING	LCD SYMBOL SCREEN	LCD TEXT SCREEN	FAULT DESCRIPTION/ MACHINE CONDITION	FOR TROUBLESHOOTING REFER TO
22	—			Horn or Horn Circuit Short	See Table 6-25
23	—			Horn Disconnected	See Table 6-26
24	—			P1 - Auxiliary #1 Circuit Short	See Table 6-27
25	—			P1 - Auxiliary #1 Circuit Disconnected	See Table 6-28
26	—			P1 - Auxiliary #2 Circuit Short	See Table 6-29
27	—			P1 - Auxiliary #2 Circuit Disconnected	See Table 6-30
28	—	RESERVED		RESERVED	
29	—	RESERVED		RESERVED	
30	6			Traction Module No Communication with Ground Control Module	See Table 6-31
31	—			Platform Control Console No Communication with Ground Control Module	See Table 6-32
32	7			Pump Motor Over Current LIFT UP Disabled	See Table 6-33
33	—	RESERVED		RESERVED	
34	—			P2 - Auxiliary #1 - Inhibit Left Hand Enable Open	See Table 6-32

Table 6-1. LCD Display - Service Fault Code Conditions

FAULT CODE	PLATFORM CONSOLE LEDs FLASHING	LCD SYMBOL SCREEN	LCD TEXT SCREEN	FAULT DESCRIPTION/ MACHINE CONDITION	FOR TROUBLESHOOTING REFER TO
35	—			P2-Auxiliary #1 - Tie Down Left Hand Enable Depressed During Machine Power-Up	See Table 6-35
36	—			Aux. # 2 - Platform Gate Open While Elevated	See Table 6-36
37	—			Aux. # 2 - Platform Gate Open While Elevated During Machine Power-up	See Table 6-37
38	2			2 LEDs/BARS Flashing with an audible beep. Platform Lift-UP Function is Locked Out.	See Page 6-33
39	1			1 LED/BAR Flashing with an audible beep. Drive and Platform Lift-UP Functions Locked Out.	See Page 6-33
40	5	Obstruction Sensor - No Communication		RESERVED	
41	—	RESERVED		RESERVED	
42	—	RESERVED		RESERVED	
43	—	RESERVED		RESERVED	
44	—	RESERVED		RESERVED	
45	—	RESERVED		RESERVED	
46	—	RESERVED		RESERVED	
100	10			Ground Control Module Fault Condition	See Table 6-38
200	10			Platform Control Console Fault Condition	See Table 6-39
300	10			Traction Control Module Fault Condition	See Table 6-40

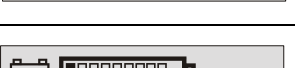
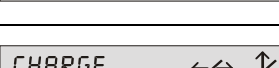
6.8 SPECIFICATIONS FOR VARIOUS COMPONENTS

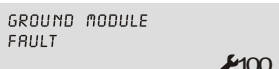
The following table contains specifications for machine components.

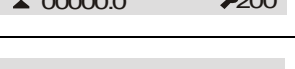
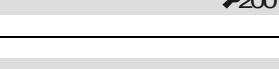
Table 6-2. Ohm Ratings for Various Components

COMPONENT	NOMINAL RESISTANCE @ TEMPERATURE	RESISTANCE RANGE POSSIBLE
Pump Motor	0.2ohm - 0.4ohm @ 77deg F	0.12ohm - 0.49ohm

Table 6-3. Amperage Draw for Various Components

COMPONENT	AMPERAGE		
Ground Control Module	95 Amps @ room temperature with rated load		
Traction Control Module (Prior to SN 0130032507)	LEVEL SURFACE (24V) (RATED LOAD)	15% GRADE (24V) (RATED LOAD)	NO LOAD (24V)
	7 to 11 Amps (per motor)	55 to 60 Amps (per motor)	3.5 to 4.8 Amps 78 to 86 RPM
Traction Control Module (SN 0130032507 to Present)	12 to 16 Amps (per motor)	75 to 80 Amps (per motor)	4.5 to 6 Amps 115 to 127 RPM

6.9 SPECIAL PIN EXTRACTOR TOOLS FOR ELECTRICAL CONNECTORS

The following table contains pin extractor tools for machine electrical connector components.

Table 6-4. Special Pin Extractor Tools for Electrical Connectors

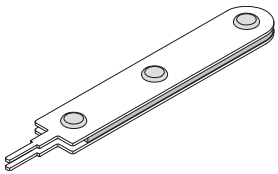
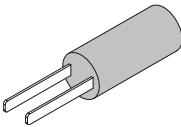
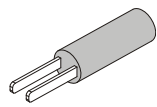
COMPONENT	DESCRIPTION	JLG PART NUMBER	ILLUSTRATION
Ground Control Station	For removal of electrical connector pins from the Ground Control Station connectors.	7016618	
Drive Motor	For removal of electrical connector pins from the Drive Motor main power connectors.	7002841	
Drive Motor Brake	For removal of electrical connector pins from the Drive Motor Brake power connectors.	7002842	

6.10 FAULT CODE TROUBLESHOOTING TABLES

Machine in Drive Speed Cut-Back (Turtle) Mode All The Time

Overview of Procedure

Under normal machine operation once the platform is elevated the machine's maximum drive speed is reduced to 1/4 the normal drive speed of when the platform is fully lowered. This is detected with a drive speed cut-back (*proximity*) switch mounted at the base of the mast assembly and a target mounted on the mast assembly. When the mast is elevated and the target raised, the proximity switch then cuts back the machine drive speed. When machine is in the drive speed cut-back mode, a turtle is displayed on the Ground Control Module LCD display.

Check for These Obvious Conditions First:

- Mast drive speed cut-back (proximity) switch and target plate secure and undamaged.

Table 6-5. Machine In Drive Speed Cut-Back (Turtle) Mode All The Time

STEP	ACTION	SPEC	YES	NO
1.	With the machine powered on and the platform fully lowered, check for continuity on the wires of the Cutback Proximity Switches. At the Ground Control Module, P2 connector, check continuity between pins-8 and 18 (switch 1) and pins 9 and 19 (switch 2).	—	Replace Ground Control Module	Repair or Replace Speed Cutback (Proximity) Switch

Obstruction Below Platform

Check for These Obvious Conditions First:

- >20 lb detected on Object Sensing Pad

NOTE: To clear the fault, perform one of the following actions:

1. The platform must be raised approximately 1 ft (while in Platform Mode) after the object has been removed.
2. Press the horn button on the Platform Control Console after the object has been removed.

Table 6-6. Obstruction Below Platform

STEP	ACTION	SPEC	YES	NO
1.	At the Ground Control Module P4 Connector, check the voltage between pin 8 (yellow/red) and Ground. Is the reading within specification?	24VDC	Continue to Step 2	Replace Ground Control Module
2.	Check continuity of the Object Sensing Pad (refer to the electrical schematic). Is there continuity between pins 1 & 4 and between pins 2 & 3?	—	Continue to Step 3	Replace Object Sensing Pad
3.	Check continuity of OSS Harness.	—	Continue to Step 4	Repair or Replace OSS Harness
4.	At the Ground Module, P4 connector, check the voltage between pin 7 (Orange/Red) and Ground. Is the reading within specification? (If reading is 0VDC when there is no weight on the Object Sensing Pad, replace the pad)	Open: 4-5 VDC Closed: 0VDC	Consult Factory	Replace the OSS Relay Board

 Code 01 - Low Battery Voltage

Check for These Obvious Conditions First:

- Battery cable ends loose or corroded at battery posts.
- Charger DC output wires from charger to batteries damaged or disconnected.

Table 6-7. Code 01 - Low Battery Voltage

STEP	ACTION	SPEC	YES	NO
1.	Does battery charger power up through diagnostic cycle when plugged in to an AC outlet?	—	Go To Step 2	See Battery/Battery Charger Servicing - Section 3 of this Manual
2.	Is the Abnormal (RED) LED lit when charger is in charge mode?	—	Go to Step 3	Charge Batteries Until 100% (Green) LED is lit. Go to Step 4
3.	Test Batteries. See Battery Condition in Section 3 of this Service Manual.	—	See Battery/Battery Charger Servicing - Section 3 of this Manual	Replace Battery
4.	Check Battery Condition. See Battery Condition in Section 3 of this Service Manual. Do the batteries pass condition tests?	—	—	Replace Batteries as Necessary

 Code 02 - RESERVED

 Code 03 - RESERVED

Code 04 - Tilt Condition

Check for These Obvious Conditions First:

- If machine is on a tilt of more than 1.5° in either or both the X or Y direction, this is normal operation. (DRIVE and LIFT UP are disabled when tilt is detected.)
- Check if Ground Control Module is mounted securely to the mast support column.

NOTE: If frequent calibration of the internal Tilt Sensor is required, replace the Ground Control Module.

Table 6-8. Code 04 - Tilt Condition

STEP	ACTION	SPEC	YES	NO
1.	Using a digital level, check the actual level of the machine's resting surface in both the X and the Y directions. Does surface check within machine specification?	1.5° X and Y Direction	Go to Step 2	Drive Machine to Level Surface
2.	At the Ground Control Module, enter the programming mode (refer to Section 3 for ground control programming) and check the tilt sensor X and Y readings. Are readings within machine specification?	1.5° X and Y Direction	Replace Ground Control Module	Go to Step 3
3.	Zero Tilt Sensor on a surface checked to within 0.0 degrees with a digital level in both the X and Y directions (refer to Section 3 for ground control programming).	—	—	—

Code 05 - Obstruction Sensor - No Communication

Check for These Obvious Conditions First:

- "OSS Enable" is set to "1"

Table 6-9. Code 05 - Obstruction Sensor - No Communication

STEP	ACTION	SPEC	YES	NO
1.	At the Ground Control Module, enter the programming mode (refer to Section 3 for ground control programming). Set "OSS Enable" to "0" to disable, or set to "2" to enable.	—	—	—

Code 06 - Drive Motor Brush Wear Warning Indicator

- Replace Drive Motor Brushes (refer to Section 3.5 for brush replacement instructions).
- Program Ground Control Station module to reset the Brush Wear Warning Timer (refer to Section 4.4 for reset instructions).

 Code 07- Left Drive Motor - Disconnected

Check for These Obvious Conditions First:

- Check left drive motor M1 connector at the Traction Control Module for secure and proper connection.

Table 6-10. Code 07 - Left Drive Motor - Disconnected

STEP	ACTION	SPEC	YES	NO
1.	Check resistance across positive (+) and negative (-) drive motor leads in M1 connector wiring harness going to the left drive motor. Is reading within spec?	0.1 to 0.3 ohms	Replace Traction Module	Go to Step 2
2.	Repair or replace left drive motor wiring, brushes or motor. (For brush replacement, see Section 3 of this Service Manual)	—	—	—

 Code 08 - Right Drive Motor - Disconnected

Check for These Obvious Conditions First:

- Check right drive motor M2 connector at the Traction Control Module for secure and proper connection.

Table 6-11. Code 08 - Right Drive Motor Disconnected

STEP	ACTION	SPEC	YES	NO
1.	Check resistance across positive (+) and negative (-) leads in M2 connector wiring harness going to the right drive motor. Is reading within spec?	0.1 to 0.3 ohms	Replace Traction Module	Go to Step 2
2.	Repair or replace right drive motor wiring, brushes or motor. (For brush replacement, see Section 3 of this Service Manual)	—	—	—

Code 09 - Left Brake - Disconnected

Check for These Obvious Conditions First:

- Check left drive motor M1 connector at the Traction Control Module for secure and proper connection.

Table 6-12. Code 09 - Left Brake - Disconnected

STEP	ACTION	SPEC	YES	NO
1.	Check resistance across positive (+) and negative (-) leads in M1 connector wiring harness going to the left drive motor brake assembly. Is reading within spec?	See Table 6-2	Replace Traction Module	Go to Step 2
2.	Repair or replace left brake wiring or left brake assembly.	—	—	—

Code 10 - Right Brake - Disconnected

Check for These Obvious Conditions First:

- Check right drive motor M2 connector at the Traction Control Module for secure and proper connection.

Table 6-13. Code 10 - Right Brake - Disconnected

STEP	ACTION	SPEC	YES	NO
1.	Check resistance across positive (+) and negative (-) leads in M2 connector wiring harness going to the right drive motor brake assembly. Is reading within spec?	See Table 6-2	Replace Traction Module	Go to Step 2
2.	Repair or replace right brake wiring or right brake assembly.	—	—	—

 **Code 11 - Left Drive Motor - Short Circuit**

Check for These Obvious Conditions First:

- Wiring harness from (M1) connector on Traction Control Module to Left Drive Motor for damage.

Table 6-14. Code 11 - Left Drive Motor - Short Circuit

STEP	ACTION	SPEC	YES	NO
1.	Remove the M1 connector from the Traction Control Module and check both the pins to the drive motor for any voltage. (Ground the meter to the Ground Control Module - Negative (-) lug.)	No Voltage	This circuit should be isolated. Repair or Replace Components as Required	Go to Step 2
2.	Check for continuity of both the pins to ground.	No Ground		Replace Traction Control Module

 **Code 12 - Right Drive Motor - Short Circuit**

Check for These Obvious Conditions First:

- Wiring harness from (M2) connector on Traction Control Module to Left Drive Motor for damage.

Table 6-15. Code 12 - Right Drive Motor - Short Circuit

STEP	ACTION	SPEC	YES	NO
1.	Remove the M2 connector from the Traction Control Module and check both the pins to the drive motor for any voltage. (Ground the meter to the Ground Control Module - Negative (-) lug.)	No Voltage	This circuit should be isolated. Repair or Replace Components as Required	Go to Step 2
2.	Check for continuity of both the pins to the drive motor to ground.	No Ground		Replace Traction Control Module

Code 13 - Traction Module - In Fold Back

Check for These Obvious Conditions First:

- Machine is operating on a continuous grade or rough terrain.

Table 6-16. Code 13 - Traction Module - In Fold Back

STEP	ACTION	SPEC	YES	NO
1.	Allow machine to cool the traction module for 30 minutes. Does the machine operate properly after cooling?	—	—	Replace Traction Module
NOTE: If this is a recurring problem compare current draw of your machine with Traction Control Module specifications in Table 6-3.				

Code 14 - Pump Motor - Disconnected

Check for These Obvious Conditions First:

- Check the Positive (+)/Negative (-) cables from the Ground Control Module to the Pump Motor studs for loose or corroded connections.

Table 6-17. Code 14 - Pump Motor - Disconnected

STEP	ACTION	SPEC	YES	NO
1.	Check resistance across the positive (+) and negative (-) studs on the pump motor.	See Table 6-2	Replace Ground Control Module	Repair or Replace Pump Motor or Motor Brushes

 **Code 15 - Lift Down Valve - Disconnected**

Check for These Obvious Conditions First:

- Inspect wire terminals on the lift down valve at the base of the lift cylinder for tight and secure connection.

Table 6-18. Code 15 - Lift Down Valve - Disconnected

STEP	ACTION	SPEC	YES	NO
1.	Check voltage at the P1 connector on the Ground Control Module between pin-10 and pin-3. Is reading within spec?	2 - 4VDC	Replace Ground Control Module	Go to Step 2
2.	Check resistance between the terminals on the lift down valve, located at the base of the lift cylinder. Is reading within spec?	60hms	Repair or Replace Wiring Harness from Ground Control Module	Replace the Lift Down Valve Solenoid
3.	With the terminals still removed from the lift down valve coil, check continuity of the wires from pins 10 and 3 on the P1 connector to the lift down valve.	.000hms	—	Repair or Replace Wiring

 **Code 16 - Lift Down Valve - Short Circuit**

Check for These Obvious Conditions First:

- Damaged wiring in the lift down valve wiring harness or a damaged lift down valve coil.

Table 6-19. Code 16 - Lift Down Valve - Short Circuit

STEP	ACTION	SPEC	YES	NO
1.	At the Ground Control Module, P1 connector, check the voltage across pins 10 and 3 to the lift down valve coil. Is reading within specification?	0 - 2VDC	Go to Step 2	Replace Ground Control Module
2.	Remove the wire terminals at the lift down valve coil. Check resistance reading of the coil. Is coil within specification?	60hms	Go to Step 3	Replace Coil
3.	With the terminals still removed from the lift down valve coil, check continuity of the wires from pins 10 and 3 on the P1 connector to the lift down valve.	.000hms	—	Repair or Replace Wiring

Code 17 - Ground Control Module - In Fold Back

Check for These Obvious Conditions First:

- Has machine been operating on a continuous grade or rough terrain for a long period of time?

Table 6-20. Code 17 - Ground Control Module - In Fold Back

STEP	ACTION	SPEC	YES	NO
1.	Allow Ground Control Module to cool for 30 minutes. Does the machine operate OK after cooling?	—	—	Replace Ground Control Module
NOTE: If this is a recurring problem, compare current draw of machine with Ground Control Module specifications in Table 6-3.				

Code 18 - Alarm - Short Circuit

Check for These Obvious Conditions First:

- Damaged wiring in the alarm wiring harness or a damaged alarm.

Table 6-21. Code 18 - Alarm - Short Circuit

STEP	ACTION	SPEC	YES	NO
1.	At the Ground Control Module, P1 connector, check the voltage across pins-13 and 6 to the alarm. Is reading within specification?	0 - 2VDC	Go to Step 2	Replace Ground Control Module
2.	Remove the wire terminals at the alarm, check continuity of each of the wires from pins 13 and 6 on the P1 connector to the alarm end.	—	Replace the Alarm	Repair or Replace Wiring

 Code 19 - Alarm - Disconnected

Check for These Obvious Conditions First:

- Damaged wiring in the alarm wiring harness or a damaged alarm.
- Activate a function to check if alarm beeps.

Table 6-22. Code 19 - Alarm - Disconnected

STEP	ACTION	SPEC	YES	NO
1.	Check voltage at the P1 connector on the Ground Control Module between pin-13 and pin-6. Is reading within specification?	2-4VDC	Replace Ground Control Module	Go to Step 2
2.	Remove the wire terminals at the alarm, check continuity of each of the wires from pins 13 and 6 on the P1 connector to the alarm end.	—	Replace the Alarm	Repair or Replace Wiring

 Code 20 - Beacon - Short Circuit

Check for These Obvious Conditions First:

- Damaged wiring in the beacon wiring harness or a damaged beacon unit.

Table 6-23. Code 20 - Beacon - Short Circuit

STEP	ACTION	SPEC	YES	NO
1.	At the Ground Control Module, P1 connector, check the voltage across pins-12 and 5 to the beacon. Is reading within specification?	0-2VDC	Go to Step 2	Replace Ground Control Module
2.	Remove the wire terminals at the beacon, check continuity of each of the wires from pins 12 and 5 on the P1 connector to the beacon end.	—	Replace the Beacon	Repair or Replace Wiring

Code 21 - Beacon - Disconnected

Check for These Obvious Conditions First:

- Is machine equipped with flashing amber beacon light?

Table 6-24. Code 21 - Beacon - Short Disconnected

STEP	ACTION	SPEC	YES	NO
1.	Is machine equipped with a flashing amber beacon light.	—	Go to Step 3	Go to Step 2
2.	At the Ground Control Module enter the programming mode, check if the Beacon light open circuit detection is enabled.	—	Disable It	Replace Ground Control Module
3.	Check voltage at the P1 connector on the Ground Control Module between pin-12 and pin-5. Is reading within specification?	2 - 4VDC	Replace Ground Control Module	Go to Step 4
4.	Remove the wire terminals at the beacon, check continuity of each of the wires from pins-12 and 5 on the P1 connector to the beacon end.	—	Replace the Beacon	Repair or Replace Wiring

Code 22 - Horn - Short Circuit

Check for These Obvious Conditions First:

- Damaged wiring in the horn wiring harness or a damaged horn unit.

Table 6-25. Code 22 - Horn - Short Circuit

STEP	ACTION	SPEC	YES	NO
1.	At the Ground Control Module, P1 connector, check the voltage across pins-14 and 7 to the horn. Is reading within specification?	0 - 2VDC	Go to Step 2	Replace Ground Control Module
2.	Remove the wire terminals at the horn, check continuity of each of the wires from pins-14 and 7 on the P1 connector to the horn end.	—	Replace the Horn	Repair or Replace Wiring

 **Code 23 - Horn - Disconnected**

Check for These Obvious Conditions First:

- Is machine equipped with a horn unit?

Table 6-26. Code 23 - Horn - Disconnected

STEP	ACTION	SPEC	YES	NO
1.	Is machine equipped with a horn unit?	—	Go to Step 3	Go to Step 2
2.	At the Ground Control Module enter the programming mode, check if the horn open circuit detection is enabled.	—	Disable It	Replace Ground Control Module
3.	Check voltage at the P1 connector on the Ground Control Module between pin-14 and pin-7. Is reading within specification?	2-4VDC	Replace Ground Control Module	Go to Step 4
4.	Remove the wire terminals at the horn, check continuity of each of the wires from pins-14 and 7 on the P1 connector to the horn end.	—	Replace the Horn	Repair or Replace Wiring

 **Code 24 - P1-Auxiliary #1 Circuit - Short Circuit**

Check for These Obvious Conditions First:

- Damaged wiring in the Auxiliary #1 Component wiring harness or a damaged Component.

Table 6-27. Code 24 - P1-Auxiliary #1 Circuit - Short Circuit

STEP	ACTION	SPEC	YES	NO
1.	At the Ground Control Module, P1 connector, check the voltage across pins-9 and 2 to the Aux. #1 component. Is reading within specification?	0-2VDC	Go to Step 2	Replace Ground Control Module
2.	Remove the wire terminals at the Aux. #1 component, check continuity of each of the wires from pins-9 and 2 on the P1 connector to the Aux. #2 component end.	—	Replace the Component	Repair or Replace Wiring

Code 25 - P1-Auxiliary #1 Circuit - Disconnected

Check for These Obvious Conditions First:

- Is machine equipped with a component on the Auxiliary #1 circuit?

Table 6-28. Code 25 - P1-Auxiliary #1 Circuit - Disconnected

STEP	ACTION	SPEC	YES	NO
1.	Is machine equipped with a component on the Auxiliary #1 circuit?	—	Go to Step 3	Go to Step 2
2.	At the Ground Control Module enter the programming mode, check if the Auxiliary #1 open circuit detection is enabled.	Default = NO	Disable It	Replace Ground Control Module
3.	Check voltage at the P1 connector on the Ground Control Module between pin-9 and pin-2. Is reading within specification?	2 - 4VDC	Replace Ground Control Module	Go to Step 4
4.	Remove the wire terminals at the Aux. #1 component, check continuity of each of the wires from pins-9 and 2 on the P1 connector to the Aux. #1 component.	—	Replace the Component	Repair or Replace Wiring

Code 26 - P1-Auxiliary #2 - Short Circuit

Check for These Obvious Conditions First:

- Damaged wiring in the Auxiliary #2 Component wiring harness or a damaged Component.

Table 6-29. Code 26 - P1-Auxiliary #2 - Short Circuit

STEP	ACTION	SPEC	YES	NO
1.	At the Ground Control Module, P1 connector, check the voltage across pins-8 and 1 to the Aux. #2 component. Is reading within specification?	0 - 2VDC	Go to Step 2	Replace Ground Control Module
2.	Remove the wire terminals at the Aux. #2 component, check continuity of each of the wires from pins-8 and 1 on the P1 connector to the Aux. #2 component end.	—	Replace the Component	Repair or Replace Wiring

 Code 27 - P1-Auxiliary #2 - Disconnected

Check for These Obvious Conditions First:

- Is machine equipped with a component on the Auxiliary #2 circuit?

Table 6-30. Code 27 - P1-Auxiliary #2 - Disconnected

STEP	ACTION	SPEC	YES	NO
1.	Is machine equipped with a component on the Auxiliary #2 circuit?	—	Go to Step 3	Go to Step 2
2.	At the Ground Control Module enter the programming mode, check if the Auxiliary #2 open circuit detection is enabled.	Default = NO	Disable It	Replace Ground Control Module
3.	Check voltage at the P1 connector on the Ground Control Module between pin-8 and pin-1. Is reading within specification?	2 - 4VDC	Replace Ground Control Module	Go to Step 4
4.	Remove the wire terminals at the Aux. #2 component, check continuity of each of the wires from pins-8 and 1 on the P1 connector to the Aux. #2 component.	—	Replace the Component	Repair or Replace Wiring

 Code 28 - RESERVED

 Code 29 - RESERVED

Go to Discount-Equipment.com to order your parts

**Code 30 - Traction Module - No Communication with Ground Control Module****Check for These Obvious Conditions First:**

- Check if the communications cable connections, P5 connector on the Ground Control Module and round plug on the Traction Control Module are seated properly in their sockets at each end.
- Check the Positive (+) (RED) and Negative (-) (BLACK) power cable connections from the Ground Control Module to the Traction Control Module are tight and secure at both ends.

Table 6-31. Code 30 - Traction Module - No Communication with Ground Control Module

STEP	ACTION	SPEC	YES	NO
1.	Check the voltage reading at the main power Positive (+)/Negative (-) cable connection on the Traction Control Module.	24v DC	Go to Step 2	Repair or Replace Positive (+) or Negative (-) Cable
2.	Remove the communications cable, P5 connector at the Ground Control Module and round connector at the Traction Control Module. Check continuity of all three (3) wires in the communications cable from end to end. P5 - Pins 2, 3, and 4.	—	Go to Step 3	Repair or Replace Wire(s)
3.	With communications cable disconnected at both ends, check for continuity between Pins 2, 3, and 4 of the P5 connector end.	—	Repair or Replace Wires	Go to Step 4
4.	Plug the communications cable on the Traction Control Module to the round socket on the opposite end of the module. Does this fix problem?	—	Done	Replace Traction Control Module
5.	Unplug the P5 connector at the Ground Control Module. Check voltage between pins 2 (- lead-in) and 5 (+ lead-in). Is voltage within spec.	4.5v DC	Done	Replace Ground Control Module

 Code 31 - Platform Control Console - No Communication with Ground Control Module

Check for These Obvious Conditions First:

- Check the harness connection at the P4 connector on the Ground Control Module and the harness connection at the other end on the Platform Junction Box.

Table 6-32. Code 31 - Platform Control Console - No Communication with Ground Control Module

STEP	ACTION	SPEC	YES	NO
1.	Check if LEDs are illuminated on the Platform Control Console.	—	Go To Step 2	Go to Step 3
2.	Remove the 9 pin Platform Control Console connector from the side of the Platform Junction Box and the P4 connector at the Ground Control Module. Check continuity from the P4 connector, pin-5 to Junction Box pin-3 and P4, pin-9 to Junction Box pin-4.	—	Repair or Replace Platform Control Console	Repair or Replace Wiring
3.	Remove the 9 pin Platform Control Console connector from the side of the Platform Junction Box. Check the voltage across pins-1 and 5 in the Junction Box connector.	24V DC	Repair or Replace Platform Control Console	Go to Step 4
4.	Check voltage across pins-10 and 2 on connector P4 at the Ground Control Module.	24V DC	Go to Step 5	Replace Ground Control Module
5.	Check continuity of P4 connector, pin-10 to Platform Junction Box pin-1. Also P4 connector, pin-2 to Platform Junction Box, pin-5.	—	Repair or Replace Wires	

Code 32 - Pump Motor - Over Current

Check for These Obvious Conditions First:

- Platform overload condition.
- Obstruction in mast system.
- Pump Positive (+) and Negative (-) connections are secure and undamaged.
- Crushed or kinked hydraulic lines.
- Hydraulic leaks

Table 6-33. Code 32 - Pump Motor - Over Current

STEP	ACTION	SPEC	YES	NO
1.	Check current draw of pump motor by elevating the platform to full height and load pump by continuing to press the UP button. Is reading within spec?	Less than 145 Amps	Go to Step 2	Go to Step 3
2.	Did unit give a 32 Fault Code while performing Step 1?	—	Replace Ground Control Module	—
3.	Is the pump hydraulic pressure setting within specification as show in Section 1.6 of this Service Manual?	See Section 1.6	Go to Step 4	Adjust to Specification
4.	Check pump motor brushes and rotor commutator for abnormal wear.	—	Replace as Required	Replace Pump Motor

Code 33 - RESERVED

Code 34 - P2-Auxiliary #1 - Inhibit

Check for These Obvious Conditions First:

- Left Hand Lift lever open.

NOTE: In the procedures below, checking continuity between pin 6 and 16 should show a closed circuit when the Left Hand Lift lever is closed. Releasing the Left Hand Lift lever will show an open circuit.

Table 6-34. Code 34 - P2-Auxiliary #1 - Inhibit

STEP	ACTION	SPEC	YES	NO
1.	At the Ground Control Module, P2 connector, check the voltage across pins-16 (orange/red 49-5) and 6 (black 12). Is reading within specification?	Open: 2-4V DC Closed: 0V DC	Go to Step 2	Replace Ground Control Module
2.	Remove the P2 connector from the Ground Station Module; check continuity of the individual wires in the platform harness (P2 to platform junction box).	—	Go to Step 3	Repair or Replace Platform Harness
3.	Check continuity of Left Hand Lift.		Consult Factory	Replace Component or Repair Wires

 Code 35 - P2-Auxiliary #1 - Tie-Down

Check for These Obvious Conditions First:

- Left Hand Lift lever closed on machine during power up.

NOTE: In the procedures below, checking continuity between pin 6 and 16 should show a closed circuit when the Left Hand Lift lever is closed. Releasing the Left Hand Lift lever will show an open circuit.

Table 6-35. Code 35 - P2-Auxiliary #1 - Tie-Down

STEP	ACTION	SPEC	YES	NO
1.	At the Ground Control Module, P2 connector, check the voltage across pins-16 (orange/red 49-5) and 6 (black 12).Is reading within specification?	Open: 2-4V DC Closed: 0V DC	Go to Step 2	Replace Ground Control Module
2.	Remove the P2 connector from the Ground Station Module; check continuity of the individual wires in the platform harness (P2 to platform junction box).	—	Go to Step 3	Repair or Replace Platform Harness
3.	Check continuity of Left Hand Lift.		Consult Factory	Replace Component or Repair Wires

 Code 36 - Auxiliary #2 - Inhibit

Check for These Obvious Conditions First:

- Platform gate open while elevated.

Table 6-36. Code 36 - Auxiliary #2 - Inhibit

STEP	ACTION	SPEC	YES	NO
1.	At the Ground Control Module, P2 connector, check the voltage across pins-15 (orange/red 49-6) and 5 (black 13).Is reading within specification?	Open: 2-4V DC Closed: 0V DC	Go to Step 2	Replace Ground Control Module
2.	Remove the P2 connector from the Ground Station Module; check continuity of the individual wires in the platform harness (P2 to platform junction box).	—	Go to Step 3	Repair or Replace Platform Harness
3.	Check continuity of platform gate switches.		Consult Factory	Replace Component or Repair Wires

Code 37 - Auxiliary #2 - Tie-Down

Check for These Obvious Conditions First:

- Platform gate open while elevated during machine power up.

Table 6-37. Code 37 - Auxiliary #2 - Tie-Down

STEP	ACTION	SPEC	YES	NO
1.	At the Ground Control Module, P2 connector, check the voltage across pins-15 (orange/red 49-6) and 5 (black 13). Is reading within specification?	Open: 32-4V DC Closed: 0V DC	Go to Step 2	Replace Ground Control Module
2.	Remove the P2 connector from the Ground Station Module; check continuity of the individual wires in the platform harness (P2 to platform junction box).	—	Go to Step 3	Repair or Replace Platform Harness
3.	Check continuity of platform gate switches.		Consult Factory	Replace Component or Repair Wires

Code 38 - Battery Voltage Low - Warning Level 2 - Two LED/LCDs Lit

To maximize battery life, it is recommended that the factory supplied batteries be charged continuously for a minimum of 4 hours or until 8 bars are lit on the ground station LCD Display before operating the machine. When drained to Warning Level 2, batteries must be charged until 8 bars are lit on the ground station LCD display to clear the fault code. Failure to do so, will result in a fault code 39.

Code 39 - Battery Voltage Low - Warning Level 3 - One LED/LCDs Lit

To maximize battery life, it is recommended that the factory supplied batteries be charged continuously for a minimum of 4 hours or until 8 bars are lit on the ground station LCD Display before operating the machine. When drained to Warning Level 1, batteries must be charged until 8 bars are lit on the ground station LCD display to clear the fault code.

Code 40 - RESERVED

Codes 41 thru 46 - RESERVED

 Codes 100 - 199 - Ground Control Module Fault Condition

Check for These Obvious Conditions First:

- All battery and harness connectors secure and undamaged on Ground Control Module.
- Batteries have sufficient charge.
- Confirm that the static ground strap attached under base frame is secure and undamaged.

Table 6-38. Codes (100 - 199) Ground Control Module - Fault Condition

STEP	ACTION	SPEC	YES	NO
1.	Recycle machine power 5 times allowing a 10 second interval between each power recycle. Does fault clear?	—	Done	Go to Step 2
2.	Which code number is displaying?	Code 103	Go to Step 3	Replace Ground Control Module
		Code 119	Go to Step 5	
3.	Confirm that both installed batteries are 12 Volt DC.	12V DC	Go to Step 4	Replace with proper Batteries
4.	Check battery voltage while charger is operating. Is voltage within specification?	Maximum of 31 Volts DC	Replace Ground Control Module	Repair or Replace Battery Charger
5.	Remove the communications cable, P5 connector at the Ground Control Module and round connector at the Traction Control Module. Check continuity of all three (3) wires in the communications cable from end to end. P5 - Pins 2, 3, and 4.	—	Go to Step 6	Repair or Replace Wire(s)
6.	With communications cable still disconnected at both ends, check for continuity between Pins 2, 3, and 4 at the P5 connector end.	—	Repair or Replace Wires	Go to Step 7
7.	Plug the communications cable on the Traction Control Module to the round socket on the opposite end of the module. Does this fix problem?	—	Done	Replace Ground Control Module

Codes 200 - 299 Platform Control Console Fault Condition

Check for These Obvious Conditions First:

- Damage to Platform Control Console wiring harness.
- Secure harness connections from Platform Control Console to Platform Junction Box to Ground Control Module.
- Confirm that the static ground strap attached under base frame is secure and undamaged.

Table 6-39. Code (200 - 299) Platform Control Console - Fault Condition

STEP	ACTION	SPEC	YES	NO
1.	Recycle machine power 5 times allowing a 10 second interval between each power recycle. Does fault clear?	—	Done	Go to Step 2
2.	Which 200 code number is displaying?	Code - 200/207/213	Go to Step 3	Replace Platform Control Module
		Code - 202/205/206	Go to Step 4	
3.	Remove the 9 pin Platform Control Module connector from the side of the Platform Junction Box and the P4 connector at the Ground Control Module. Check continuity from the P4 connector, pin-5 to Junction Box pin-3 and P4, pin-9 to Junction Box pin-4. Is there continuity on these wires?	—	Replace Platform Control Module	Repair or Replace Wiring
4.	Perform the Joystick Calibration Procedure in Section 4.5 of this Service Manual. Does this clear the fault code?	—	Done	Replace Platform Control Module

 **Codes (300 - 399) Traction Control Module - Fault Condition**

Check for These Obvious Conditions First:

- Damage to Traction Control Module wiring harness.
- Confirm that the static ground strap attached under base frame is secure and undamaged.

Table 6-40. Codes (300 - 399) Traction Control Module - Fault Condition

STEP	ACTION	SPEC	YES	NO
1.	Recycle machine power 5 times allowing a 10 second interval between each power recycle. Does fault clear?	—	Done	Go to Step 2
2.	Is a code number displaying on the Ground Control Station?	Code - 316	Go to Step 3	Replace Traction Control Module
		Code - 325	Go to Step 5	—
3.	Confirm that both installed batteries are 12 Volt DC.	12V DC	Go to Step 4	Replace with proper Batteries
4.	Check battery voltage while charger is operating. Is voltage within specification?	Maximum of 31V DC	Replace Traction Control Module	Repair or Replace Battery Charger
5.	Check for short in harness wires from Ground Control Station connector P5 to Traction Module (round din plug). Note: This harness contains 6 wires but only 3 are used. Refer to the electrical schematics for further representation.	—	Repair or Replace Wiring	—

6.11 MAIN POWER CIRCUIT TROUBLESHOOTING

Machine Will Not Power Up

Check for These Obvious Conditions First:

- Battery voltage is 24 volts (sufficient charge in batteries to operate machine).
- Positive (+) and negative (-) battery cable connections clean and tight at both the Batteries and the Ground Control Module lugs.
- Main Power Selector Switch (key) positioned to either Platform or Ground Control Mode.
- Emergency stop buttons on both the Ground Control Module and the Platform Control Console in the RESET position (out).

Table 6-41. Machine Will Not Power UP

STEP	ACTION	SPEC	YES	NO
1.	Check for 24VDC at the positive (+) and negative (-) main power cable connections on the Ground Control Module.	24V DC	Go to Step 2	Replace the 175 Amp Inline Fuse on the Positive power cable
2.	Check continuity of the Emergency Stop wires running to the Platform Control Console, pins-10 and 1 on the P4 connector at the Ground Control Module.	—	Replace the Ground Control Module	Go to Step 3
3.	Remove the 9-pin Platform Control Console connector at the Platform Junction Box and check continuity between pins-1 and 2 to the Emergency Stop Switch in the Platform Control Console cable.	—	Go to Step 4	Replace the Platform Control Console
4.	Check continuity of the wires running from the P4 connector on Ground Control Module to the Platform Junction Box; P4 connector, Pin-1 to Junction Box Pin-2 and P4 connector, Pin-10 to Junction Box Pin-1	—	Replace Platform Control Console	Repair or Replace Wiring

6.12 MAST TROUBLESHOOTING

Platform Will Not Lower Manually

Check for These Obvious Conditions First:

- Is there an obstruction in the mast assembly?
- Is there a restricted (smashed) hydraulic line?
- Are the mast slide pads shimmed properly (not too tight) per Mast Assembly procedure in Service Manual?

Table 6-42. Platform Will Not Lower Manually

STEP	ACTION	SPEC	YES	NO
1.	Check to see if the platform will lower from the Ground Control Station in Ground Control Mode.	—	Repair or Replace the Manual Descent Control Valve	Go to Step 2
2.	Check to see if the lift down valve is opening completely.	—	Go to Step 3	Replace the Lift Down Valve
3.	Check the flow valve in the lift cylinder for a restriction.	—	Clean or Replace Flow Valve	Consult Factory
4.	If equipped with Remote Manual Descent, check cable assembly to ensure valve is actuated.	—		Replace Remote Manual Descent Assembly

Platform Lift Up and Down Jerky

Overview of Procedure

The following procedure suggests areas on the machine which might attribute to erratic movement of the platform during lift up and down.

Check for These Obvious Conditions First:

- If mast is not running smooth or has tight and rough spots, refer to the Mast Section Rebuild.
- Hydraulic oil level in reservoir tank at full level.
- Hydraulic oil is not milky (presence of water) or foamy (full of air).

Table 6-43. Platform Lift Up and Down Jerky

STEP	ACTION	SPEC	YES	NO
CONTROLS (ELECTRICAL)				
1.	Is platform control console, platform enable, up or down pad defective or worn out?	—	Replace pad	Go to Step 2
2.	Loose connections, ground and power.	—	Repair connection	Go to Step 3
3.	Valve solenoid keeps opening and closing.	—	Repair Connection or Replace Valve	Go to Step 4
4.	Problem internal to the Ground Control Module.	—	Replace Module	Go to Step 5
STEP	ACTION	SPEC	YES	NO
HYDRAULIC				
5.	Is the hydraulic valve working properly.	—	Go to Step 6	Replace Valve
6.	Pump drive cavatating.	—	Replace Pump	Go to Step 7
7.	Lift cylinder.	—	Rebuild or Replace Cylinder	—

Mast Noisy When Lifting And Lowering

Overview of Procedure

This procedure examines components of the mast itself and as well as its lifting components for dirt, debris, proper lubrication and operation.

Table 6-44. Mast Noisy when Lifting and Lowering

STEP	ACTION	SPEC	YES	NO
1.	Do slide pads and slide pad channels need to be cleaned of dust, dirt, or other debris?	—	Clean Pads and Channels	Go to Step 2
2.	Do mast chains need to be lubricated per JLG specification in the Service Manual?	—	Lubricate as Required	Go to Step 3
3.	Are the chain/cable sheave wheels dry and need lubrication? Note: Plastic wheels will howl on the sheave pin when they are dry. Sheave wheels may seize to the sheave pin and the pin may turn in the pin retainer blocks.	—	Lubricate or Replace Sheave Pins and Wheels	Go to Step 4
4.	Are the sequence cables (located on the side of mast) chattering when the springs are compressed? Note: This noise is normal at the sequence cable sheave wheels when the mast is completely lowered. However if the sequence cable chattering is happening no matter what position the mast is in, it could be a result of the mast being shimmed to tight or dirt and debris in the slide pad channels causing the mast to be tight.	—	Clean Slide Pads/Channels or Re-shim Mast per Service Manual	Go to Step 5
5.	Is the bore of the lift cylinder dry?	—	Replace Packing or Lift Cylinder	Go to Step 6
6.	Are the bearings in the lift pump motor and pump drive worn?	—	Repair or Replace Pump	Go to Step 7
7.	Are the hydraulic lines vibrating together?	—	Adjust the Position of the Lines	Go to Step 8
8.	Check if the pump motor is loose to it's mounting plate.	—	Tighten pump mounting fasteners	Go to Step 9
9.	Hydraulic oil could be cavatating inside the pump.	—	Repair or Replace Pump	—

Platform (Mast) Won't Stay Elevated

Overview of Procedure

The following procedure requests that the lift down, dump, and pump internal valves be checked to see if any are stuck open, it also examines the lift down and dump valve circuits. Also suggests that the lift cylinder packing could be leaking internally.

Check for These Obvious Conditions First:

- Manual descent valve is closed tight.

Table 6-45. Platform (Mast) Won't Stay Elevated

STEP	ACTION	SPEC	YES	NO
1.	Is the lift down valve stuck open?	—	Repair or Clean Valve	Go to Step 2
2.	Lift down valves could be open due to incorrect electrical signal.	—	Check Pump Valve Electrical Circuit	Go to Step 3
3.	Oil could be passing around the lift cylinder bore packing.	—	Replace or Rebuild the Lift Cylinder	—

Platform (Mast) Descends Too Slowly

Overview of Procedure

The following procedure examines the mast some hydraulic components for obstructions and defects.

Table 6-46. Platform (Mast) Descends Too Slowly

STEP	ACTION	SPEC	YES	NO
1.	Check mast slide pads shimmed to tight.	—	Reshim Mast	Go to Step 2
2.	Is there an obstruction in the mast?	—	Remove Obstruction	Go to Step 3
3.	The lift cylinder packing could be too tight in the bore of the cylinder barrel.	—	Rebuild or Replace Cylinder	Go to Step 4
4.	Check if the lift down valve is opening completely.	—	Clean or Replace Valve	Go to Step 5
5.	Is there a restricted hydraulic line (smashed)?	—	Replace Hydraulic Line	Go to Step 6
6.	Check the flow valve in the cylinder valve block for a restriction, i.e. dirt.	—	Clean or Replace Flow Valve	—

6.13 HYDRAULIC LEAK TROUBLESHOOTING

Miscellaneous Hydraulic Leak Troubleshooting

Overview of Procedure

This series of steps gives remedies for various areas of the machine where leaks could occur.

Table 6-47. Hydraulic Leak Troubleshooting

STEP	ACTION	SPEC	YES	NO
1.	Oil leaking around the lift cylinder rod.	—	Replace the Seal at the end of the Piston and Cylinder Barrel	—
2.	Oil leaking around the cylinder extend or return line fittings.	—	Tighten or Replace Fittings	—
3.	Oil leaking around the hydraulic lines.	—	Tighten or Replace Hydraulic Lines	—
4.	Oil leaking around the lift down valve.	—	Tighten Cartridge in Pump Case	—
5.	Oil leaking around the (Red) manual descent valve.	—	Replace Lift Down Valve	—
6.	Oil leaking around the material Power Tray (if equipped).	—	Tighten/replace components as required	—

NOTE: Do not overtighten the nut on the solenoid in step 5.

6.14 BASE FRAME COMPONENTS TROUBLESHOOTING

Caster Wheels Not Operating Freely

Check for These Obvious Conditions First:

- Is machine operating on a smooth, level surface?

Table 6-48. Caster Wheels Not Operating Freely

STEP	ACTION	SPEC	YES	NO
1.	Is the caster rotating freely?	—	Go to Step 2	Lubricate or Replace Caster Housing
2.	Is the wheel spinning freely?	—	Go to Step 3	Lubricate or Replace Wheel
3.	Is debris stuck in the rubber wheel?	—	Remove Debris or Replace Wheel	—

6.15 DRIVE SYSTEM TROUBLESHOOTING

Won't Climb Grade

Overview of Procedure

The following procedure checks the drive motor and attached components for component failure, misadjustment due to wear.

Check for These Obvious Conditions First:

- Batteries are fully charged (24 volts)
- Speed control is set to maximum
- Is grade within the maximum allowable specification of 15% grade?
- Does the travel surface allow for proper drive wheel traction?
- Is platform load within the maximum rated capacity?

Table 6-49. Won't Climb Grade

STEP	ACTION	SPEC	YES	NO
1.	Does machine drive straight on a level surface?	—	Go to Step 2	Refer to Machine Won't Drive Straight (Table 6-51)
2.	Do the left and right drive motor brakes release properly and allow the drive wheels to rotate freely?	—	Go to Step 4	Dragging? Repair, Replace or Adjust Brakes
3.	Check the amperage output of the on the drive motor leads. They should not exceed maximum amperage while pulling a grade.	—	Controller will Shut Drive Down and will flash a 7 LED Code	Go to Step 5
4.	Check the condition of the drive motor brushes.	—	OK, go to Step 6	Worn down, replace brushes or drive motor
5.	If all above is OK, Drive motors are working properly. Consult Factory.	—	—	—

Machine Drives in Opposite Direction

Table 6-50. Machine Drive in Opposite Direction

STEP	ACTION	SPEC	YES	NO
1.	At the Traction Control Module, check if the left drive motor power lead is plugged into the M1 socket.	—	Go to Step 2	Switch the Left and Right Drive Motor Power Leads at the Traction Module
2.	Remove the Right Drive Motor power lead at the Traction Control Module (M2) and check if the WHITE wire is connected to the positive (+) terminal and the BLACK wire is connected to the negative (-) terminal. (Refer to appropriate electrical schematic at end of this section.)	—	Go to Step 3	Rewire as Necessary
3.	Remove the Left Drive Motor power lead at the Traction Control Module (M1) and check if the BLACK wire is connected to the positive (+) terminal and the WHITE wire is connected to the negative (-) terminal. The Left Motor Power lead is reversed from the Right Motor lead due to the reverser harness. (Refer to appropriate electrical schematic at end of this section.)	—	Consult Factory	Rewire as Necessary

Machine Won't Drive Straight

Overview of Procedure

The following procedure examines the drive motor assembly weldments attaching the drive motors to the base frame. Also internal components of the drive motors, torque hub, and a check of the components between the torque hub and the drive wheels.

Check for These Obvious Conditions First:

- Battery voltage 24 volts (fully charge batteries)
- Nothing is lodged between one of the wheels and the base frame.
- A caster wheel on the front of the machine is seized up, creating resistance.

Table 6-51. Machine Won't Drive Straight

STEP	ACTION	SPEC	YES	NO
1.	Check for the following on the drive assembly, drive attachment weldments; is bent, has broken welds, or loose hardware.	—	Repair/Replace/Tighten weldment	Go to Step 2
2.	Check for the following on the drive assembly, drive motor mounting plates; are bent, are square with drive weldments, or is hardware loose?	—	Repair/Replace/Tighten weldment	Go to Step 3
3.	Check for the following on the drive assembly, drive motor hardware; is hardware loose.	—	Repair/Replace/Tighten component	Go to Step 4
4.	Check the left and right drive motor brakes for loose hardware & not releasing properly.	—	Tighten or Adjust per procedure in this Service Manual	Go to Step 5
5.	Is the electrical signal and amperage draw to the drive motors equal? Check with machine on level surface.	See Table 6-3	Recheck Steps 1 thru 5	Go to Step 6
6.	Check the drive motor brushes, do they need replaced?	—	Replace per procedure in this Service Manual	Go to Step 7
7.	Is joystick control defective? If possible, swap out with another platform control.	—	Repair/Replace Platform control	Go to Step 8
8.	Is the Traction Control Module defective or connections not tight? If possible, swap out with another Traction Control Module.	—	Tighten Connections or Replace Traction Control Module	Go to Step 9
9.	Inside the drive motor torque hub, check if the drive shaft is excessively loose & condition of drive shaft bearings. Are any gears broken or gear teeth excessively worn?	—	Repair/Replace torque hub components per procedure in this Service Manual	

Noise From Drive Assembly

Overview of Procedure

The following procedure examines the drive motor assembly weldments attaching the drive motors to the base frame. Also internal components of the drive motors, torque hub and a check of the components between the torque hub and the drive wheels.

Check for These Obvious Conditions First:

- Battery voltage 24 volts. (Fully charge batteries)
- Nothing is lodged between one of the wheels and the base frame.
- A caster wheel on the front of the machine is seized up, creating resistance.

Table 6-52. Noise from Drive Assembly

STEP	ACTION	SPEC	YES	NO
1.	Check for the following on the drive assembly, drive attachment weldment; is bent, has broken welds, or loose hardware.	—	Repair/Replace/Tighten weldment	Go to Step 2
2.	Check for the following on the drive assembly, drive motor hardware; is hardware loose.	—	Repair/Replace/Tighten Component	Go to Step 3
3.	Check the left and right drive motor brakes for loose hardware & not releasing properly.	—	Tighten or Adjust per procedure in this Service Manual	Go to Step 4
4.	Is the electrical signal and amperage draw to the drive motors equal? Check with machine on level surface.	See Table 6-3	Recheck Steps 1 thru 5	Go to Step 5
5.	Check the drive motor brushes, do they need replaced?	—	Replace per procedure in this Service Manual	Go to Step 6
6.	Inside the drive motor torque hub check if; the drive shaft is excessively loose & condition of drive shaft bearings. Are any gears broken or gear teeth excessively worn.	—	Repair/Replace torque hub components per procedure in this Service Manual	

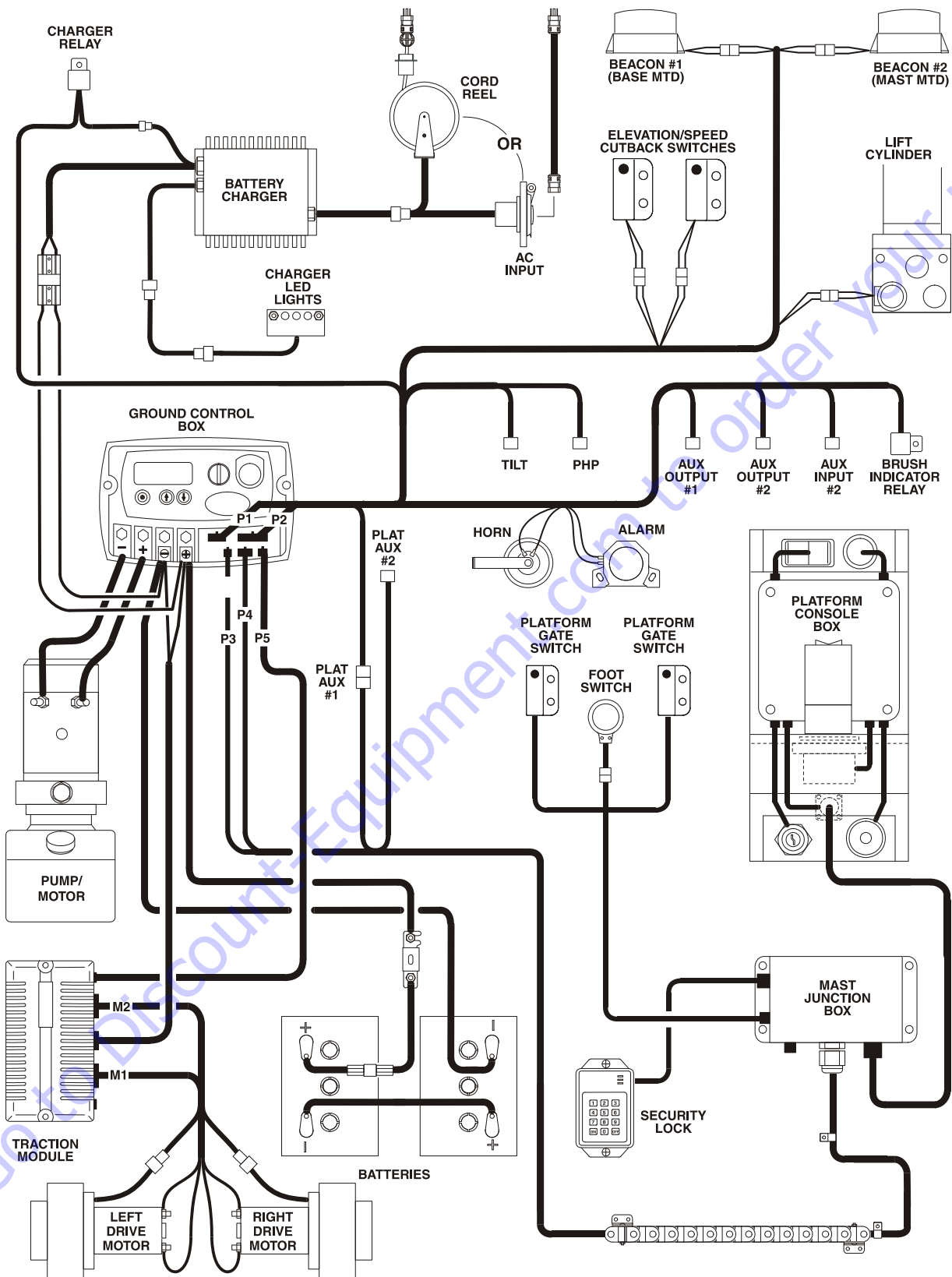

Figure 6-8. Electrical Components Installation (with 2-12V Batteries)

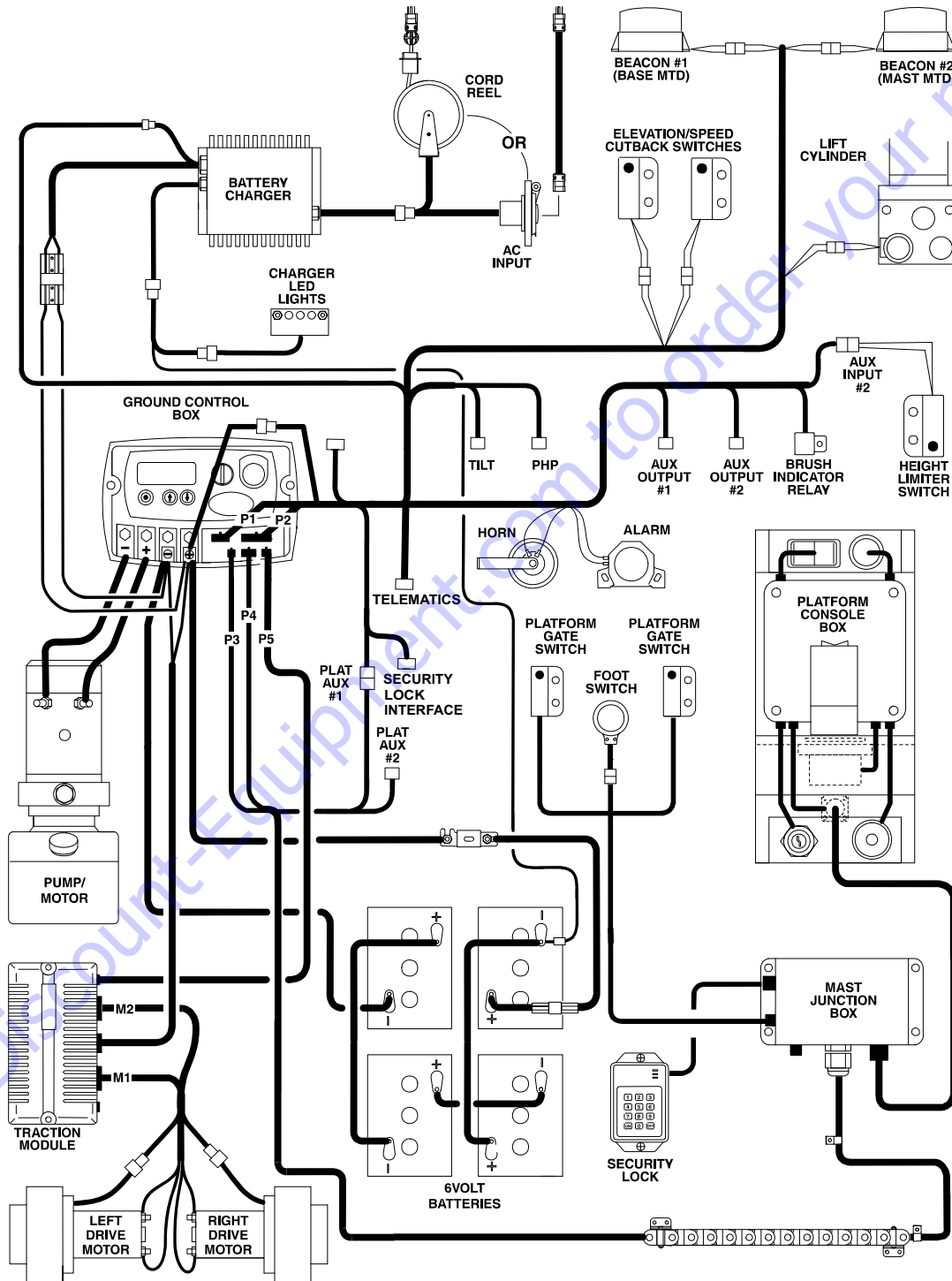

Figure 6-9. Electrical Components Installation (with 4-6V Batteries)

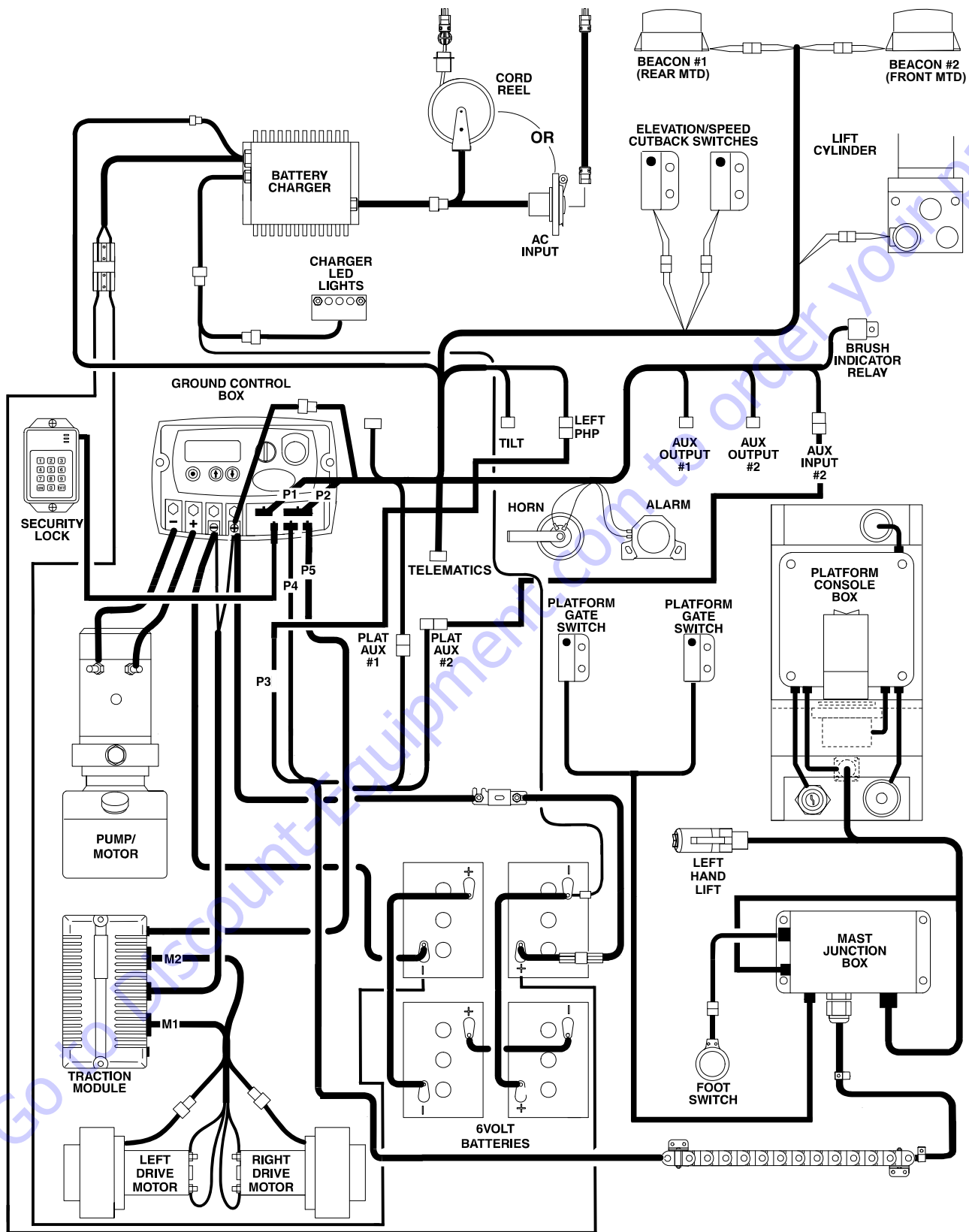

Figure 6-10. Electrical Components Installation (SN 0130032507 to Present)

This page left blank intentionally

Go to Discount-Equipment.com to order your parts

SECTION 6 - TROUBLESHOOTING

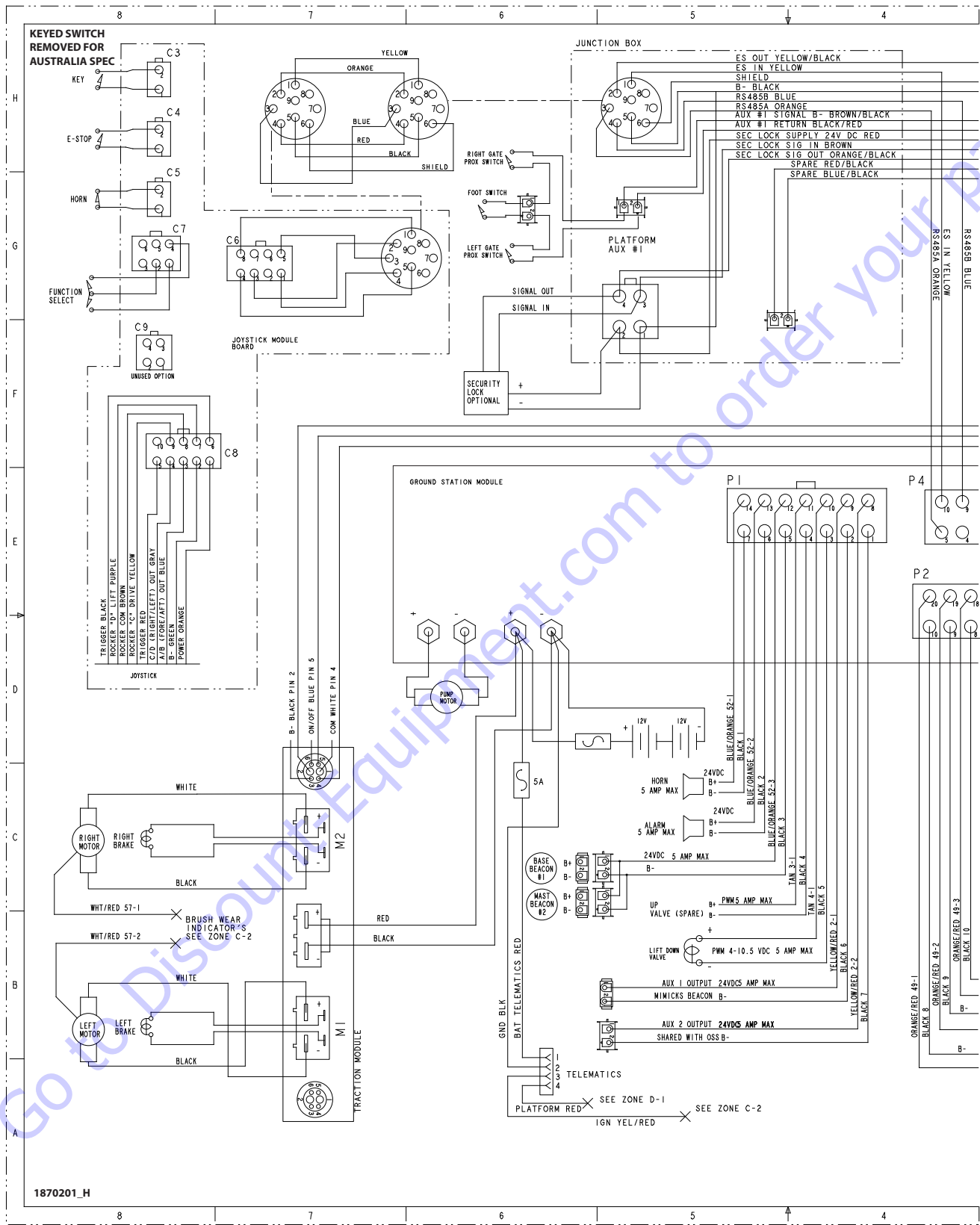

Figure 6-11. Electrical Schematic - Sheet 1 of 2 (Prior to SN 0130032507)

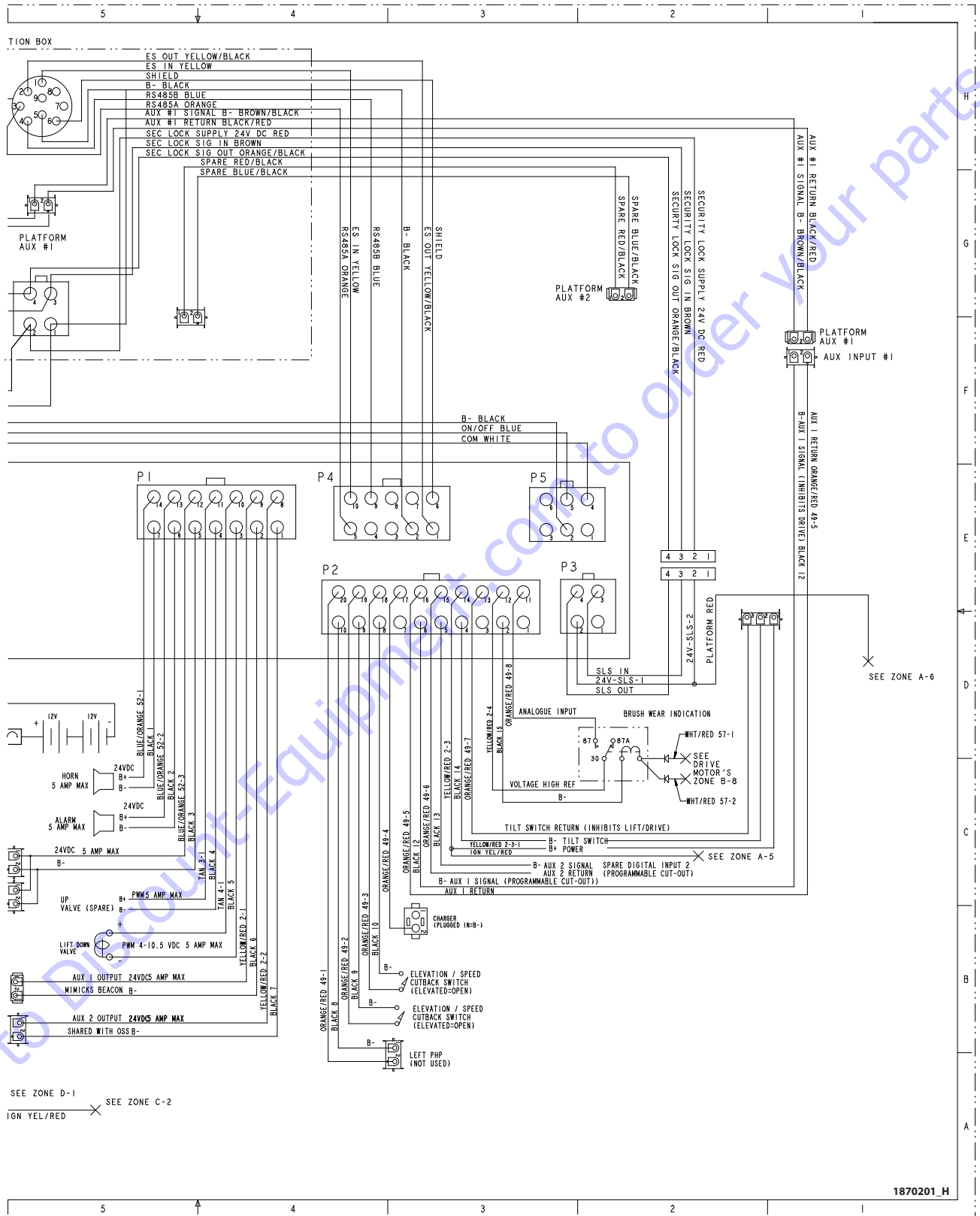

Figure 6-12. Electrical Schematic - Sheet 2 of 2 (Prior to SN 0130032507)

SECTION 6 - TROUBLESHOOTING

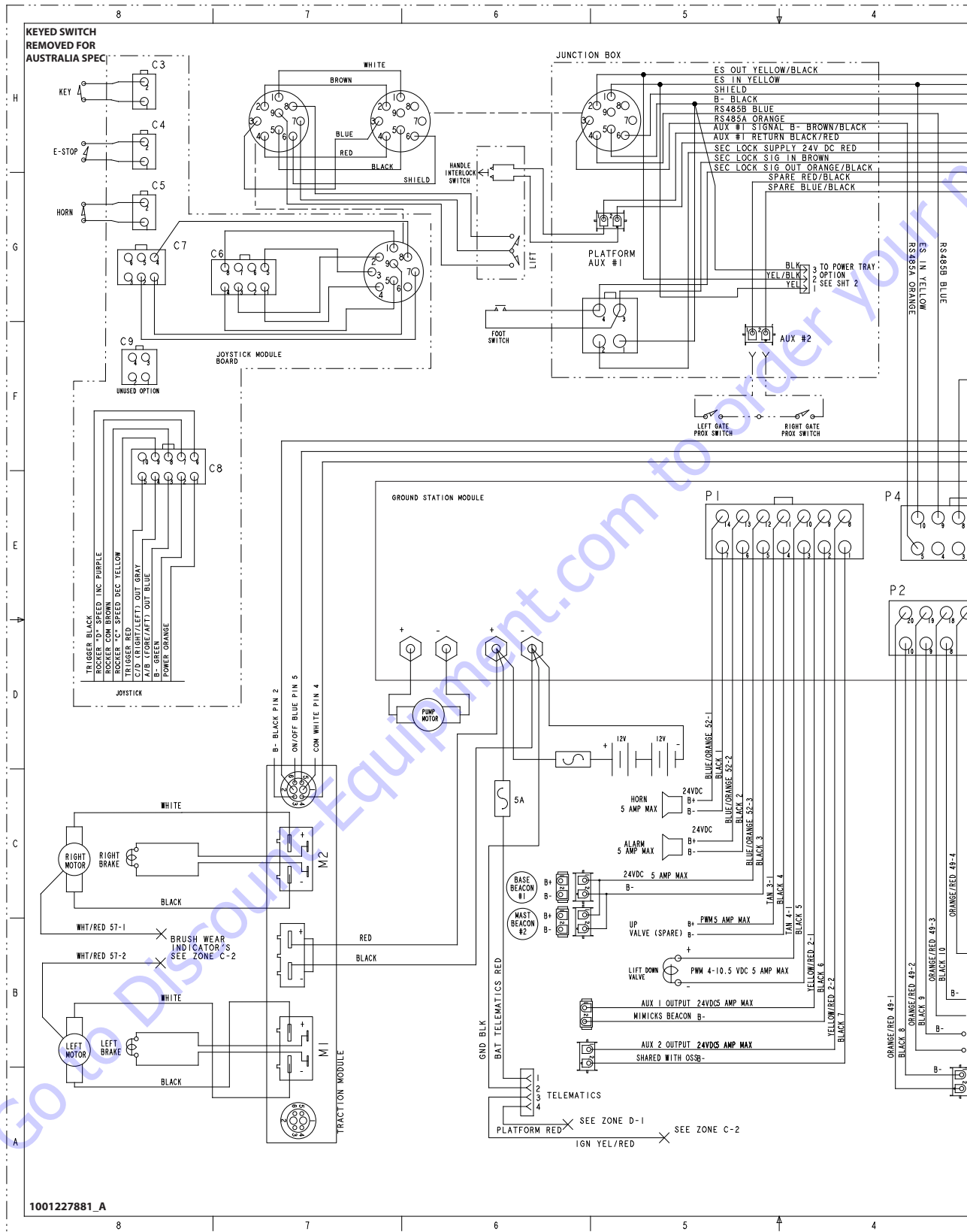

Figure 6-13. Electrical Schematic - Sheet 1 of 4 (SN 0130032507 to Present)

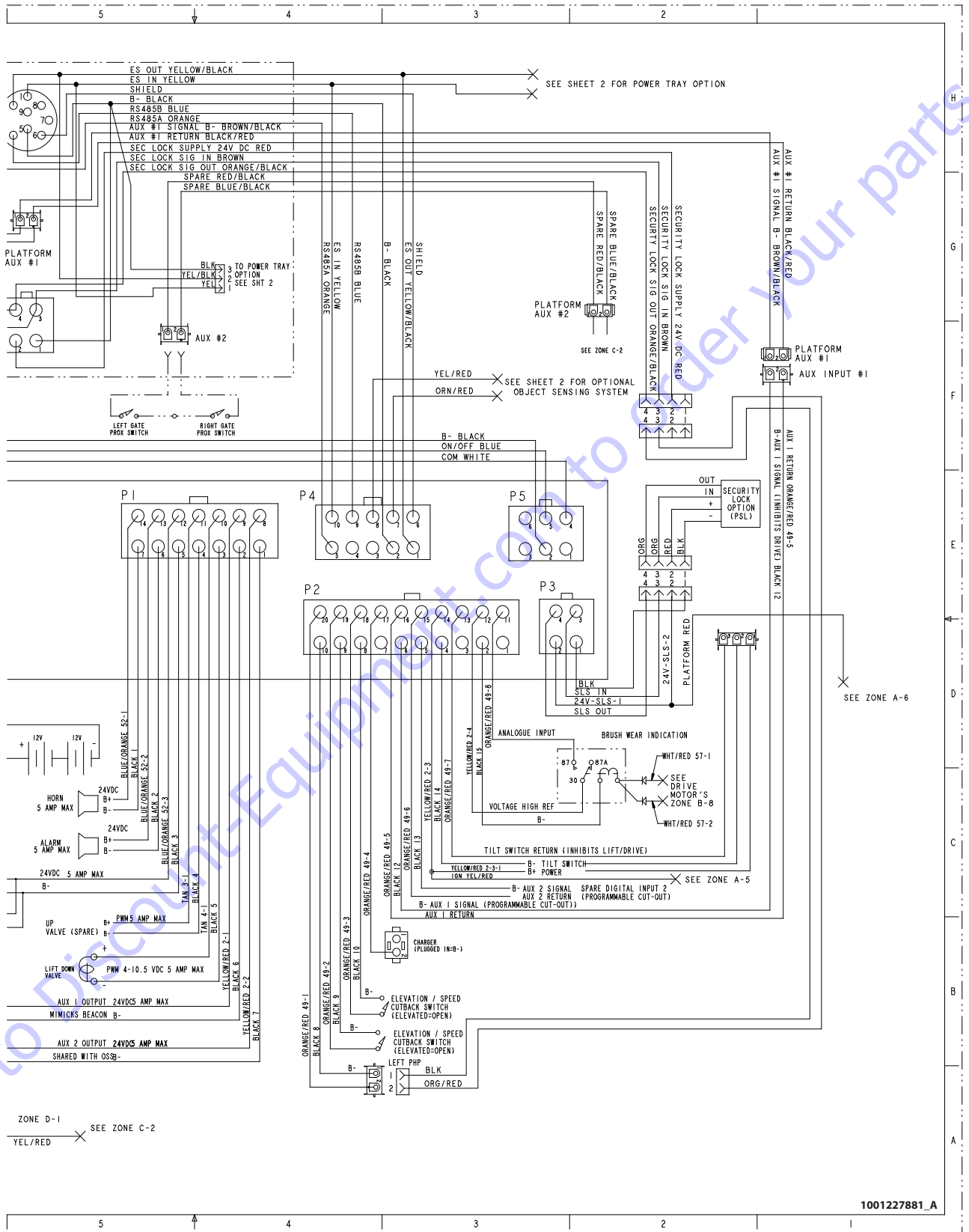

Figure 6-14. Electrical Schematic - Sheet 2 of 4 (SN 0130032507 to Present)

SECTION 6 - TROUBLESHOOTING

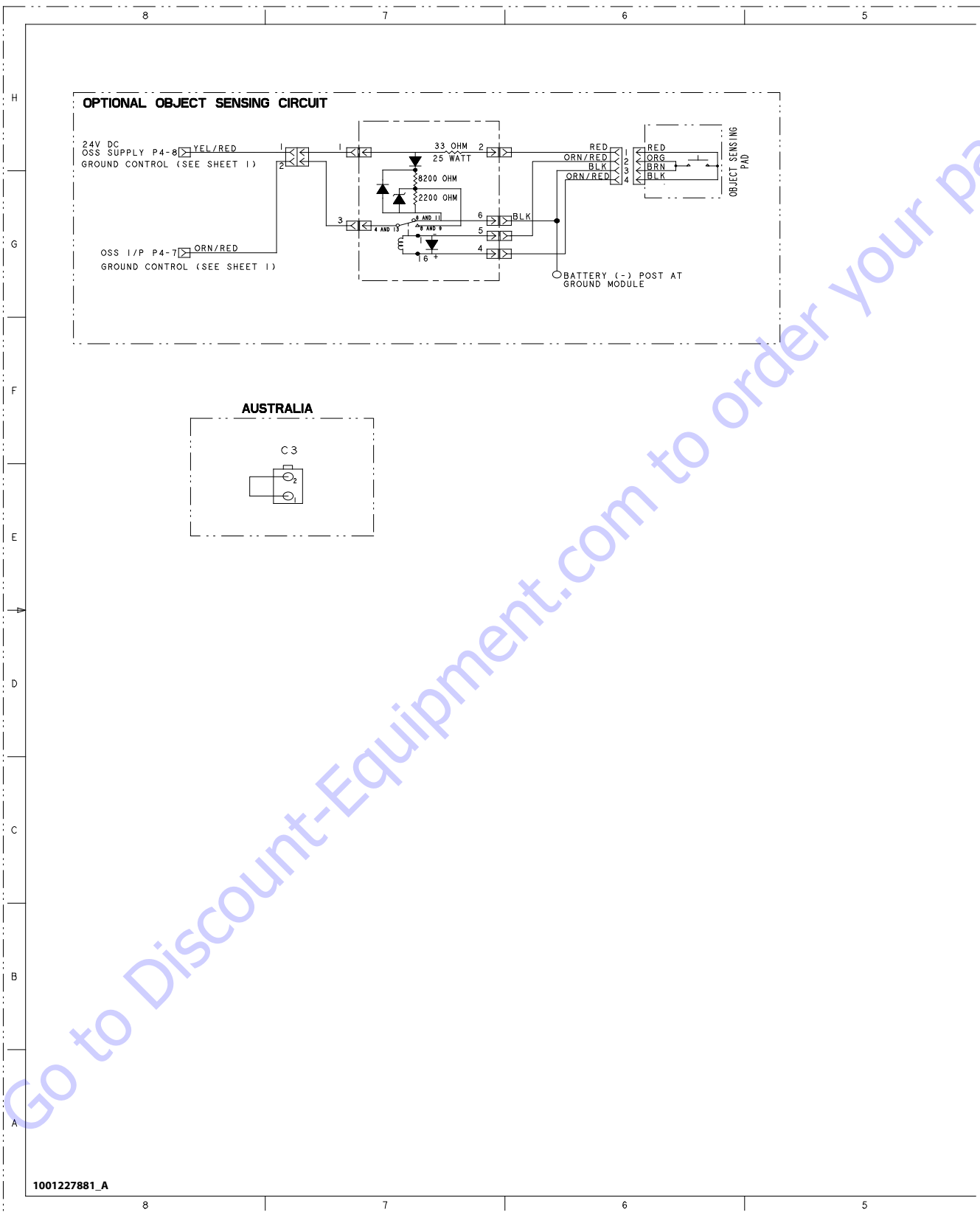

Figure 6-15. Electrical Schematic - Sheet 3 of 4 (SN 0130032507 to Present)

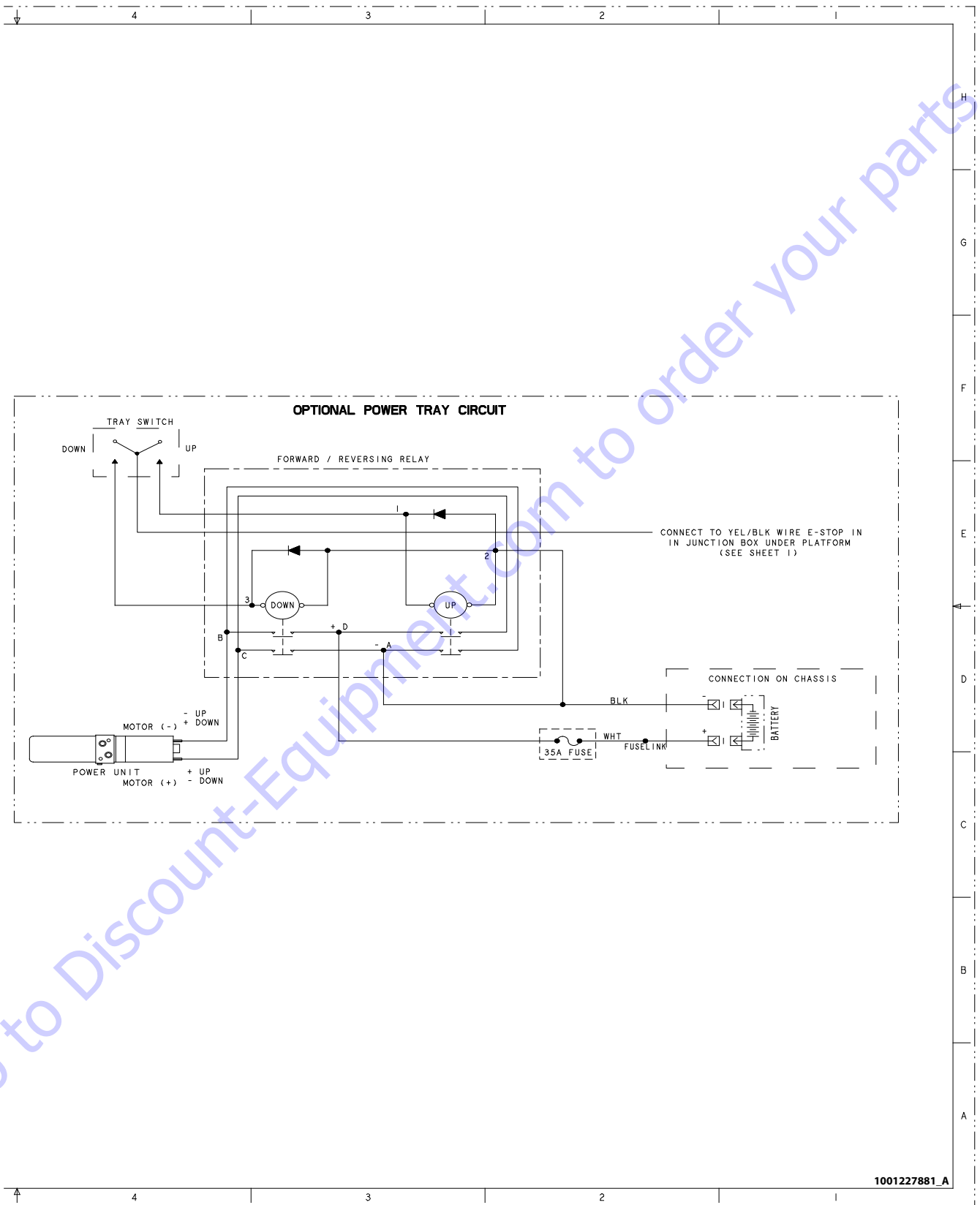
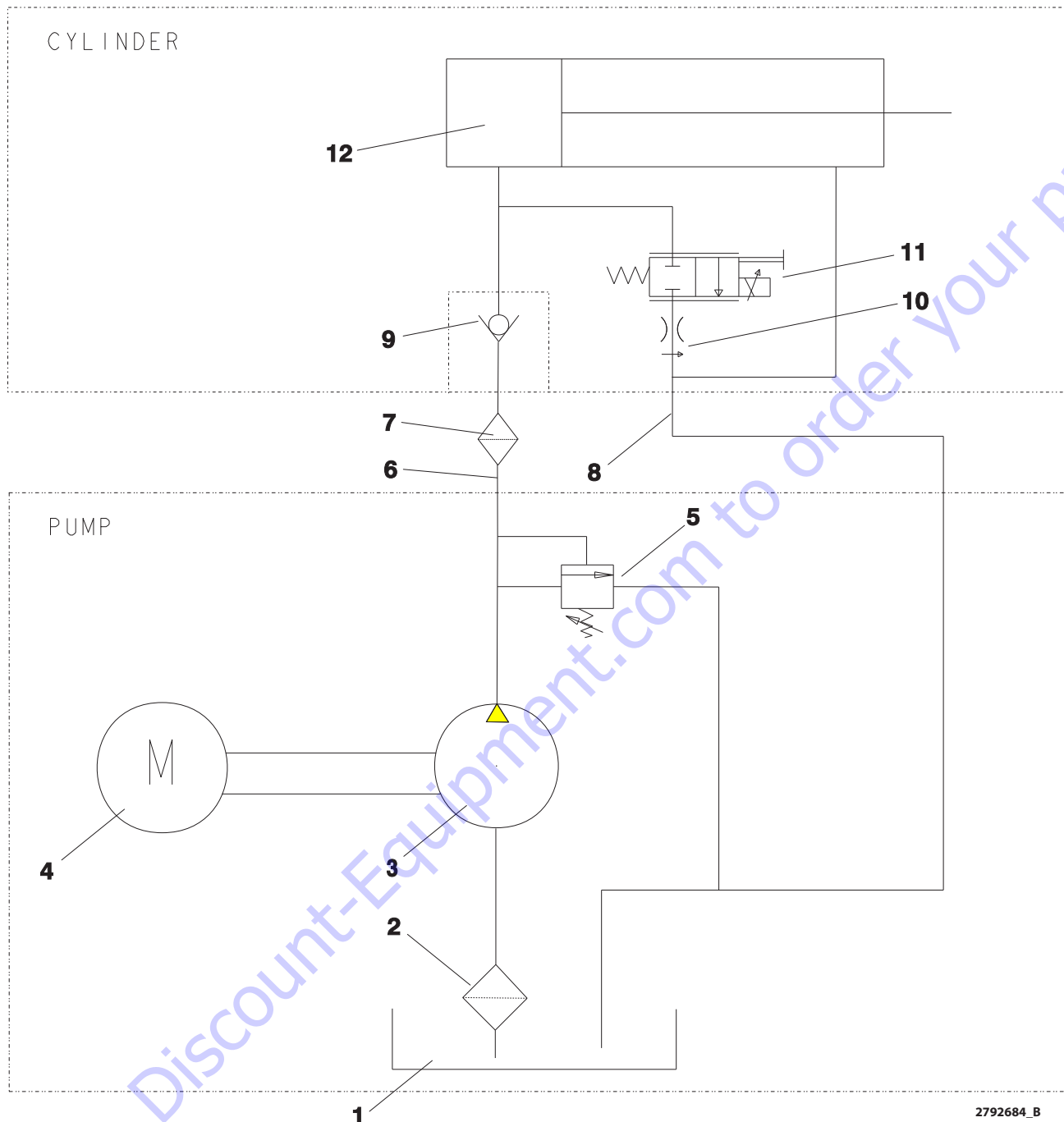

Figure 6-16. Electrical Schematic - Sheet 4 of 4 (SN 0130032507 to Present



2792684_B

- | | |
|--------------------------|---|
| 1. Tank | 7. Hydraulic Filter |
| 2. Filter Screen | 8. Return Line |
| 3. Pump | 9. Check Valve |
| 4. Pump Motor | 10. Pressure Compensator - Flow Control Valve |
| 5. Pressure Adjust Valve | 11. Manual Descent Valve |
| 6. Extend Valve | 12. Lift Cylinder |

Figure 6-17. Hydraulic Schematic

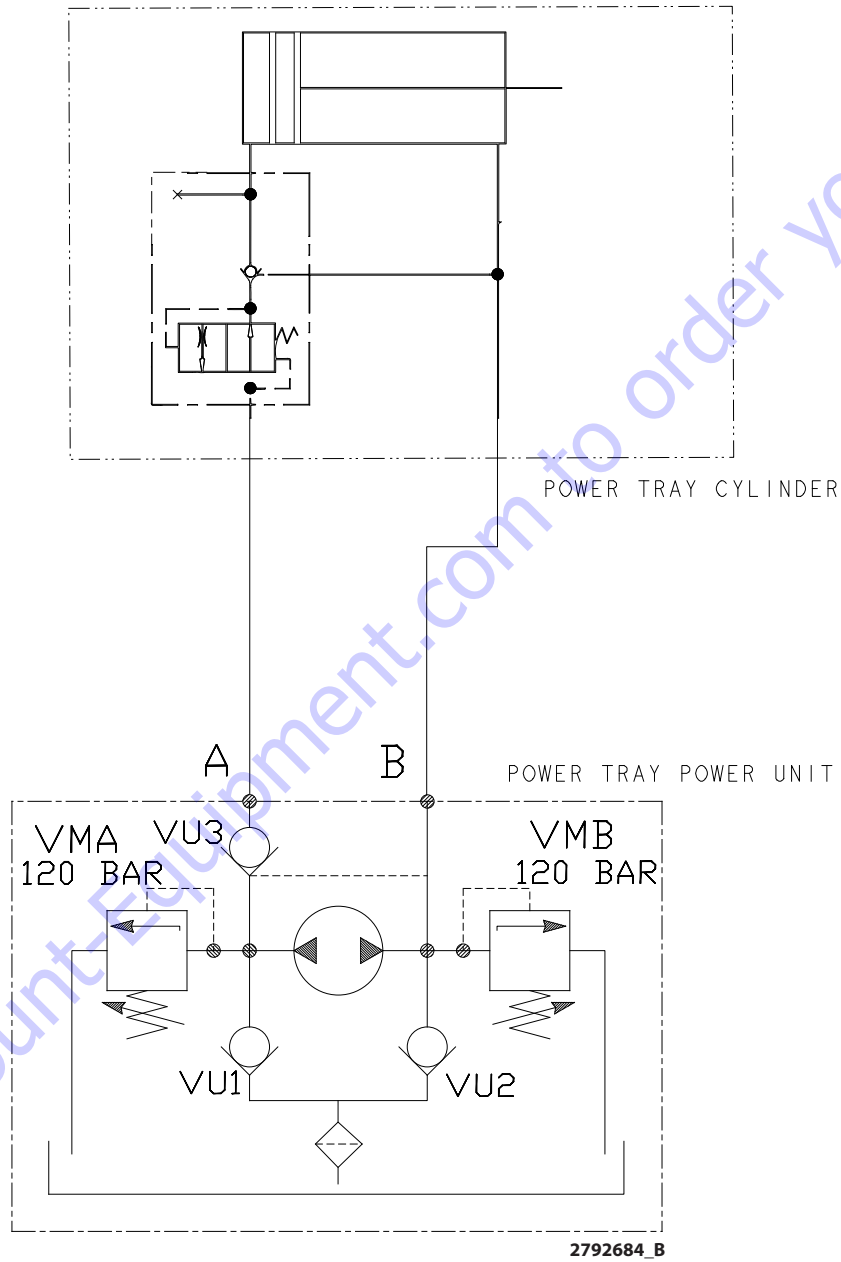

Figure 6-18. Hydraulic Schematic -Power Tray (If Equipped)



3121228



An Oshkosh Corporation Company

Go to Discount-Equipment.com to order your parts



www.Discount-Equipment.com

