



THE
BARRETO

MODEL E30SG-CP STUMP GRINDER
EXPLODED VIEWS WITH PART NUMBERS

CONGRATULATIONS!

You are now the proud owner of a BARRETO stump grinder. The following pages have detailed views of your trencher, along with corresponding part numbers.

Thank you for your patronage and confidence in BARRETO equipment.

Machine Identification Record

BARRETO Customer number _____

Machine model number _____

Machine serial number _____

Engine manufacturer _____

Engine model number _____

Engine serial number _____

Go to Discount-Equipment.com to order your parts

PARTS FINDER

**Search Website
by Part Number**



**Search Manual
Library For Parts
Manual & Lookup Part
Numbers – Purchase
or Request Quote**

Search Manuals

Enter your information to help us find the right parts manual for your machine.

* Brand:

* Model:

* Serial:

* Part Number:

SEARCH

**Can't Find Part or
Manual? Request Help
by Manufacturer,
Model & Description**

Parts Order Form

Please fill in the following information to help us find the right part for your machine.

Manufacturer:	<input type="text"/>
Model:	<input type="text"/>
Description:	<input type="text"/>
Part Number:	<input type="text"/>
Quantity:	<input type="text"/>
Notes:	<input type="text"/>

Submit

Discount-Equipment.com is your online resource for quality parts & equipment.

Florida: **561-964-4949** Outside Florida TOLL FREE: **877-690-3101**

Need parts?

Click on this link: <http://www.discount-equipment.com/category/5443-parts/> and choose one of the options to help get the right parts and equipment you are looking for. Please have the machine model and serial number available in order to help us get you the correct parts. If you don't find the part on the website or on one of the online manuals, please fill out the request form and one of our experienced staff members will get back to you with a quote for the right part that your machine needs.

We sell worldwide for the brands: Genie, Terex, JLG, MultiQuip, Mikasa, Essick, Whiteman, Mayco, Toro Stone, Diamond Products, Generac Magnum, Airman, Haulotte, Barreto, Power Blanket, Nifty Lift, Atlas Copco, Chicago Pneumatic, Allmand, Miller Curber, Skyjack, Lull, Skytrak, Tsurumi, Husquvarna Target, Stow, Wacker, Sakai, Mi-T-M, Sullair, Basic, Dynapac, MBW, Weber, Bartell, Bennar Newman, Haulotte, Ditch Runner, Menegotti, Morrison, Contec, Buddy, Crown, Edco, Wyco, Bomag, Laymor, EZ Trench, Bil-Jax, F.S. Curtis, Gehl Pavers, Heli, Honda, ICS/PowerGrit, IHI, Partner, Imer, Clipper, MMD, Koshin, Rice, CH&E, General Equipment, Amida, Coleman, NAC, Gradall, Square Shooter, Kent, Stanley, Tamco, Toku, Hatz, Kohler, Robin, Wisconsin, Northrock, Oztec, Toker TK, Rol-Air, APT, Wylie, Ingersoll Rand / Doosan, Innovatech, Con X, Ammann, Mecalac, Makinex, Smith Surface Prep, Small Line, Wanco, Yanmar

ITEM NO.	QTY.	PART NO.	DESCRIPTION
1	1	12364CP	HOSE, VALVE MID / MOTOR FRONT
2	1	00536	CUTTER HEAD ASSEMBLY
3	1	12385CP	HOSE, CASE DRAIN
4	2	04451-04	DECAL, "30-SG"
5	1	00537	CYLINDER ASSEMBLY
6	1	12365CP	HOSE, VALVE LOWER / MOTOR REAR
7	1	00535	PIVOT HEAD
8	2	10964	TRACK, 180 X 36 X 72
9	8	05042	NUT, LUG, 1/2-20 NF
10	2	10874	TRACK SPROCKET
11	1	00334-SG	CARRIAGE, RIGHT
12	1	12358T	HOSE, PUMP - CUTTER VALVE
13	13	05102	WASHER, 1/2 SAE ZINC HARDENED
14	8	05323	HH CAP SCREW, 1/2-13 NC X 1-1/4 G5 ZINC
15	2	00366	MID ROLLER ASSY
16	4	11155	ROLLER SPACER, SHORT
17	2	11447	HH CAP SCREW, 1/2-13 NC X 2-1/2 G5 ZN
18	4	05129	HH CAP SCREW, 1/2-13 NC X 1-3/4 G5 ZINC
19	1	00499CP	LID ASSEMBLY
20	1	11178	LID GASKET
21	1	03341-18	DECAL, S/N, 2WD
22	1	11239	VENT HOSE ASSEMBLY
23	1	00498-OB	CONTROL ASSEMBLY
24	1	00326	WEIGHT & BATTERY OPTIONS
25	1	00333-SG	CARRIAGE, LEFT
26	1	03503	SIGHT GAUGE
27	1	10361	FITTING, 6409-8 PLUG
28	1	03040-57	DECAL, "HYDRAULIC OIL LEVEL"
29	1	01270S	FRAME, STUMP CUTTER
30	1	00541 R1	CHIP SHIELD
31	1	00390-OB-B-S30	ENGINE / PUMPS ASSEM..B&S 30

RELEASE DATE	XX/XX/XXXX
REVISED DATE	NEW
REVISION #	0

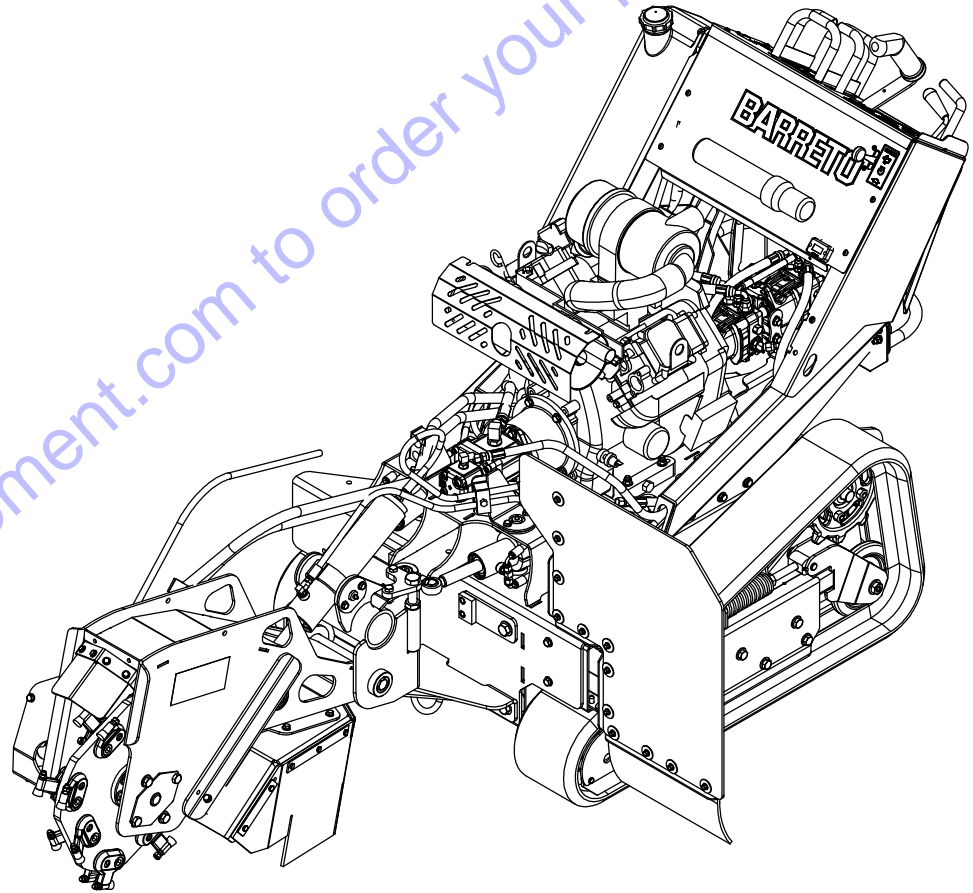

BARRETO

TITLE:	MACHINE ASSEMBLIES
PRODUCT LINE:	30SG
SCALE:	1:16
SHEET 1 OF 2	DWG# E30SG-OB

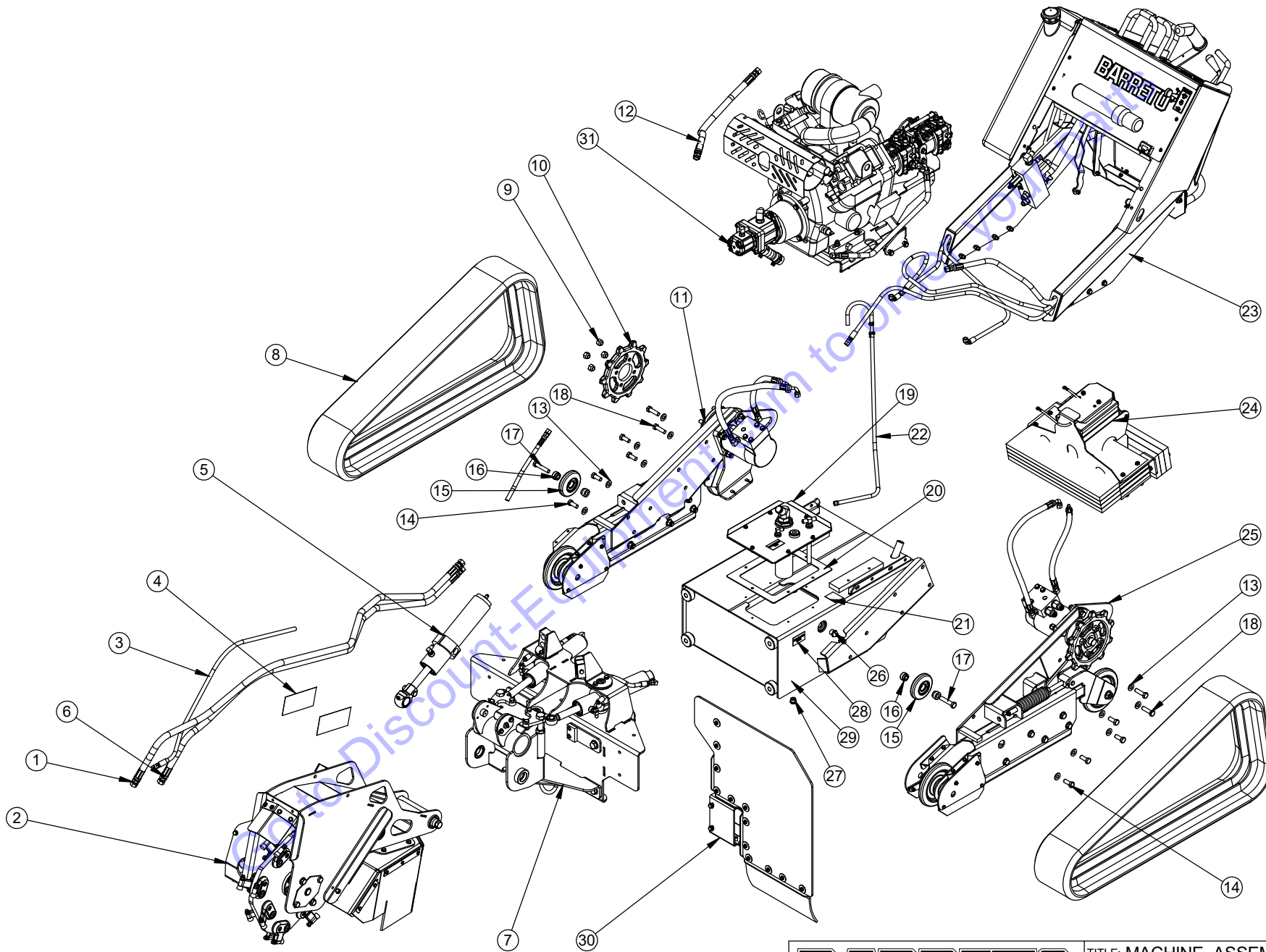

BARRETO

TITLE: MACHINE ASSEMBLIES
 X
 PRODUCT LINE: 30SG
 SCALE: 1:20
 SHEET 2 OF 2

DATE:
 DWG# E30SG-0BB

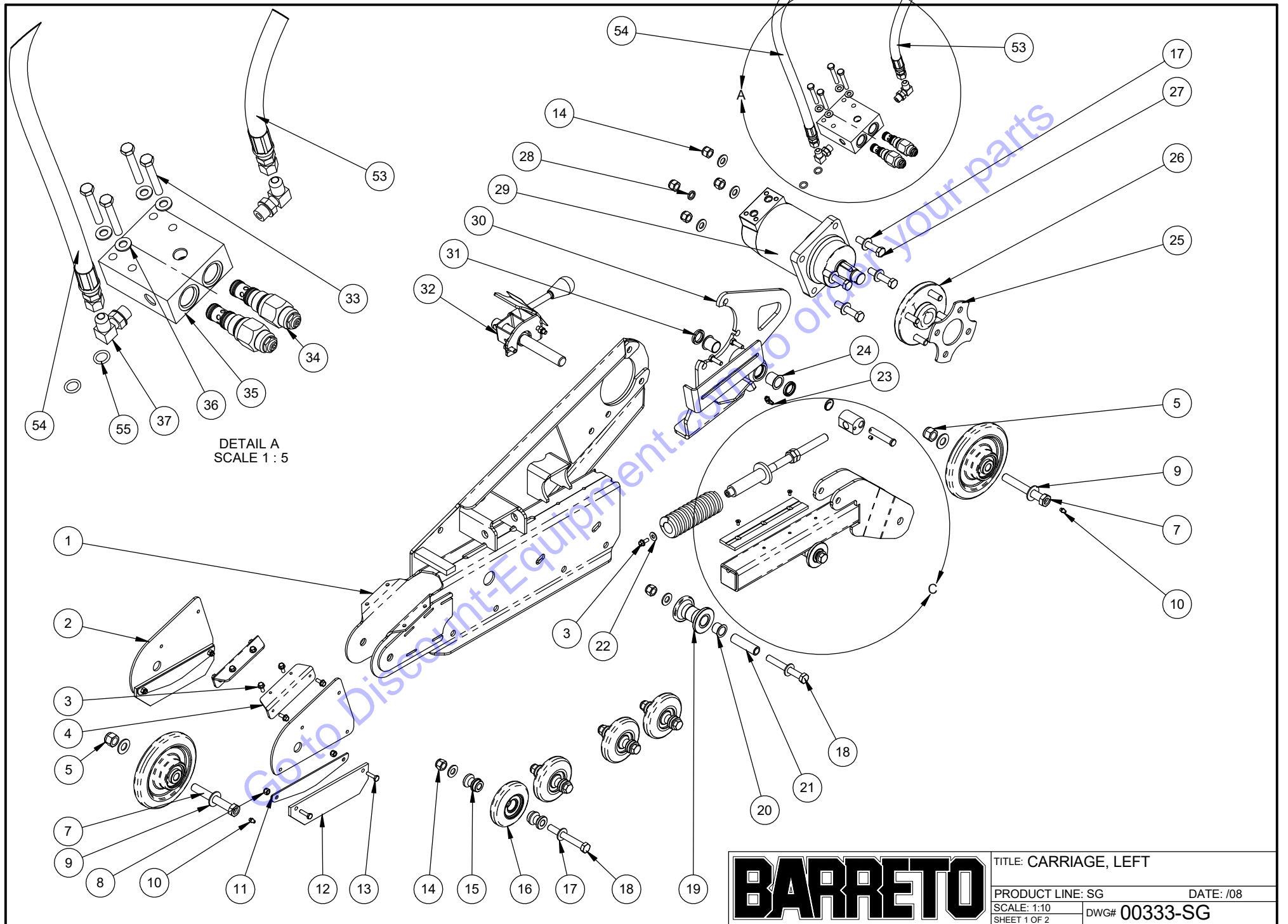

DETAIL A
SCALE 1 : 5

BARRETO

TITLE: CARRIAGE, LEFT	
PRODUCT LINE: SG	DATE: /08
SCALE: 1:10	DWG# 00333-SG
SHEET 1 OF 2	

ITEM NO.	QTY.	PART NO.	DESCRIPTION	ITEM NO.	QTY.	PART NO.	DESCRIPTION
1	1	10849-L	LEFT CARRIAGE	47	1	11470	SPRING GUIDE
2	2	11247	ROLLER GUARD	48	1	10910	ARM SLIDER
3	9	05069	WHIZ LOCK, 1/4-20 NC X 5/8 ZINC	49	2	05084	HEX SOCKET FH CAP SCREW, #10-24 X 3/8
4	2	11251	ROLLER GUARD MOUNT	50	1	11674	SPRING, CENTURY D-1378
5	2	05099	NUT, NYLOCK, 5/8-11 NC ZINC	51	1	11677	WEIGHT STOP
6	2	00335	IDLER ASSEMBLY	52	2	05315	HH CAP SCREW, 5/16-18 NC X 1 G5 ZINC
7	2	11490	ROLLER AXLE, 5/8 X 4-1/2"	53	1	12369	HOSE, LEFT DRIVE REAR - PUMP LH
8	4	05096	NUT, NYLOCK, 1/4-20 NC ZINC	54	1	12338	HOSE, LEFT DRIVE FRONT - RT
9	4	05272	WASHER, 5/8 SAE ZINC HARDENED	55	2	03226	O-RING, 2-112N70, 11/16 OD X 3/32 SECTION
10	2	05044	GREASE ZERK, 1/4-28 UNF				
11	2	11474	FLAP BACKING				
12	2	11475	FLAP				
13	4	05237	HH CAP SCREW, 1/4-20 NC X 1 G5 ZINC				
14	10	05098	NUT, NYLOCK, 1/2-13 NC ZINC				
15	8	11144	ROLLER SPACER				
16	4	00366	MID ROLLER ASSY				
17	19	05102	WASHER, 1/2 SAE ZINC HARDENED				
18	6	05590	HH CAP SCREW, 1/2-13 NC X 4 G5 ZINC				
19	2	10907	ARM ROLLER				
20	4	10272	BUSHING, IGUS MFI-1214-12				
21	2	10908	SPACER				
22	1	05078	WASHER, 1/4 USS ZINC				
23	1	05307	GREASE ZERK, 1/4-28 UNF 90°				
24	2	11680	BUSHING, IGUS LFI-1416-16				
25	1	12354	SPROCKET SHIM				
26	1	10827	WHEEL HUB, 1-1/4" TAPERED, SOLID				
27	4	11447	HH CAP SCREW, 1/2-13 NC X 2-1/2 G5 ZN				
28	1	03290	SPACER WASHER, .532 X .750 X .125				
29	1	04029	MOTOR, PARKER TF 0240WE080				
30	1	11462-L	WEIGHT MOUNT, E-BRAKE				
31	2	11711	ROD WIPER, .875 X 1.25 X .188				
32	1	00458-SG	PARK BRAKE ASSEMBLY				
33	4	05566	HH CAP SCREW, 5/16-18 NC X 2 G5 ZINC				
34	2	04405	C-BALANCE CARTRIDGE, CB10-HV				
35	1	12329	C-BALANCE MANIFOLD, SDC10-3S				
36	4	05068	WASHER, 5/16 SAE ZINC				
37	2	04538	FITTING, 6801-6-6				
38	2	11159	SPRING, POLY-U, CENT#U1000-3000-80A				
39	1	10876	IDLER ARM				
40	1	05021	SET SCREW, 1/4-20 UNC X 5/16, CUP POINT				
41	1	05250	CLEVIS PIN, 1/2 X 2-1/2 ZINC				
42	1	11156	TENSIONER END				
43	1	05039-7	CIRCLE COTTER, CC-7				
44	2	10707	NUT, JAM, 5/8-11 NC ZINC				
45	1	11170	TENSIONER STUD				
46	1	11157	WASHER, TENSION SPRING				

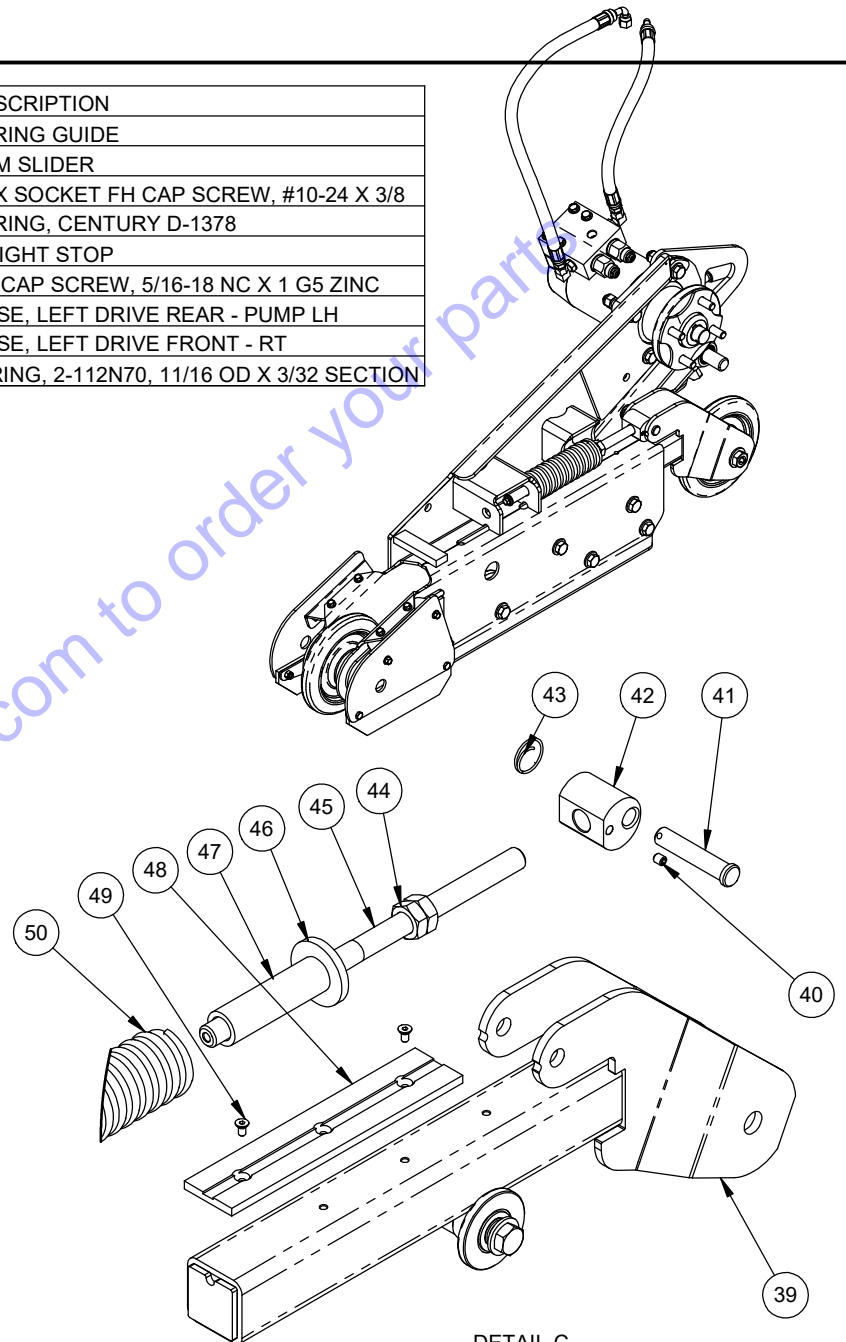

DETAIL C
SCALE 1 : 5



TITLE: LEFT CARRIAGE	
PRODUCT LINE: STUMP CUTTER	DATE: 12-12
SCALE: 1:10	DWG# 00333-SG
SHEET 2 OF 2	

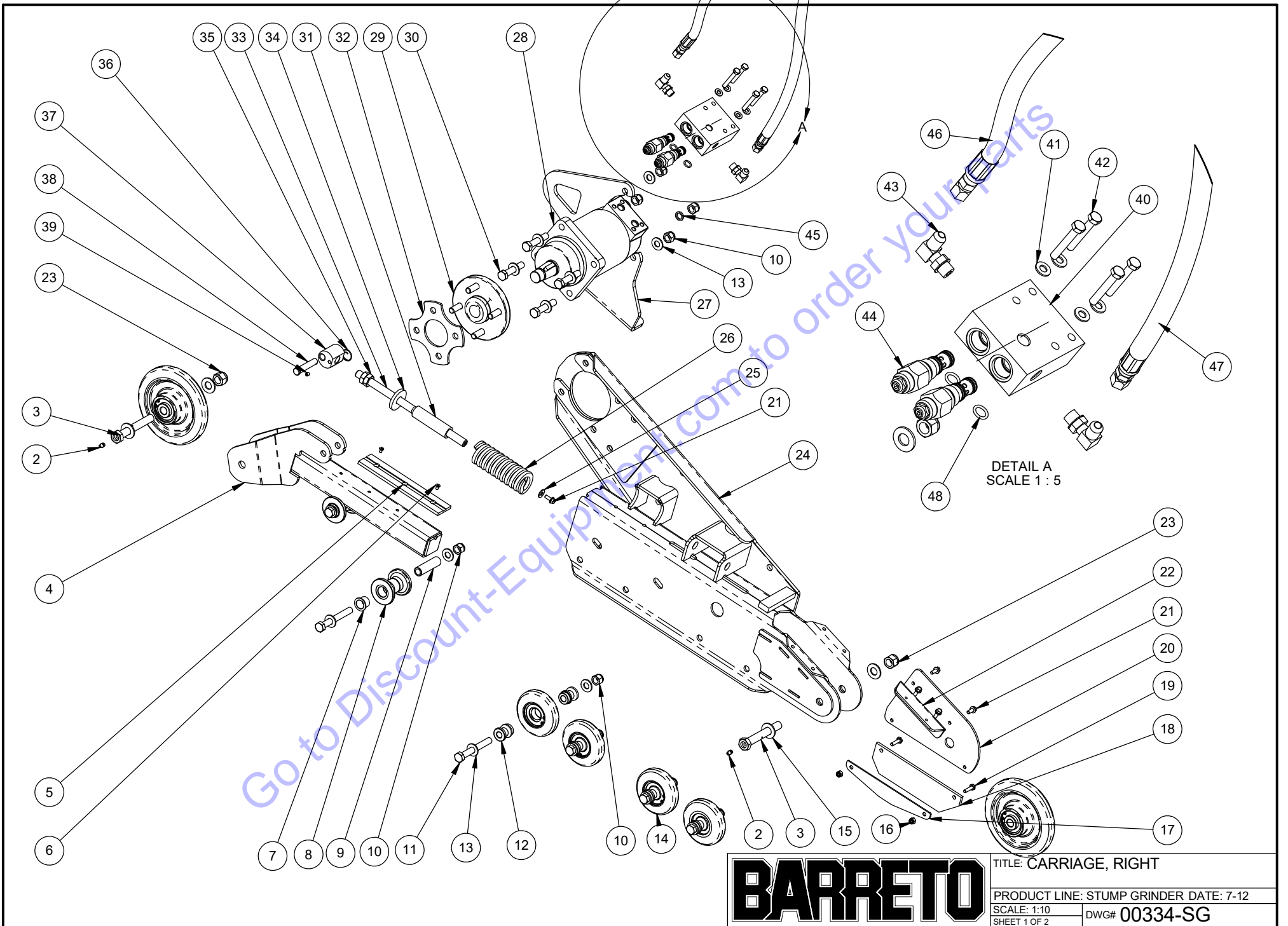

TITLE: CARRIAGE, RIGHT
 PRODUCT LINE: STUMP GRINDER DATE: 7-12
 SCALE: 1:10 DWG# 00334-SG
 SHEET 1 OF 2

TEM NO.	QTY.	PART NO.	DESCRIPTION	TEM NO.	QTY.	PART NO.	DESCRIPTION
1	2	00335	IDLER ASSEMBLY	46	1	12368	HOSE, RT DRIVE, REAR - PUMP LH
2	2	05044	GREASE ZERK, 1/4-28 UNF	47	1	12367	HOSE, SG30 RT DRIVE, FRONT- PUMP LH
3	2	11490	ROLLER AXLE, 5/8 X 4-1/2"	48	2	03226	O-RING, 2-112N70, 11/16 OD X 3/32 SECTION
4	1	10876	IDLER ARM				
5	1	10910	ARM SLIDER				
6	2	05084	HEX SOCKET FH CAP SCREW, #10-24 X 3/8				
7	4	10272	BUSHING, IGUS MFI-1214-12				
8	2	10907	ARM ROLLER				
9	2	10908	SPACER				
10	10	05098	NUT, NYLOCK, 1/2-13 NC ZINC				
11	6	05590	HH CAP SCREW, 1/2-13 NC X 4 G5 ZINC				
12	8	11144	ROLLER SPACER				
13	19	05102	WASHER, 1/2 SAE ZINC HARDENED				
14	4	00366	MID ROLLER ASSY				
15	4	05272	WASHER, 5/8 SAE ZINC HARDENED				
16	2	05096	NUT, NYLOCK, 1/4-20 NC ZINC				
17	1	11474	FLAP BACKING				
18	1	11475	FLAP				
19	2	05237	HH CAP SCREW, 1/4-20 NC X 1 G5 ZINC				
20	1	11247	ROLLER GUARD				
21	5	05069	WHIZ LOCK, 1/4-20 NC X 5/8 ZINC				
22	1	11251	ROLLER GUARD MOUNT				
23	2	05099	NUT, NYLOCK, 5/8-11 NC ZINC				
24	1	10849-R	RIGHT CARRIAGE				
25	1	05078	WASHER, 1/4 USS ZINC				
26	1	11674	SPRING, CENTURY D-1378				
27	1	11462-R	WEIGHT MOUNT, RIGHT				
28	1	04029	MOTOR, PARKER TF 0240WE080				
29	1	10827	WHEEL HUB, 1-1/4" TAPERED, SOLID				
30	4	11447	HH CAP SCREW, 1/2-13 NC X 2-1/2 G5 ZN				
31	1	11470	SPRING GUIDE				
32	1	12354	SPROCKET SHIM				
33	1	11170	TENSIONER STUD				
34	1	11157	WASHER, TENSION SPRING				
35	2	10707	NUT, JAM, 5/8-11 NC ZINC				
36	1	05039-7	CIRCLE COTTER, CC-7				
37	1	11156	TENSIONER END				
38	1	05250	CLEVIS PIN, 1/2 X 2-1/2 ZINC				
39	1	05021	SET SCREW, 1/4-20 UNC X 5/16, CUP POINT				
40	1	12329	C-BALANCE MANIFOLD, SDC10-3S				
41	4	05068	WASHER, 5/16 SAE ZINC				
42	4	05566	HH CAP SCREW, 5/16-18 NC X 2 G5 ZINC				
43	2	04538	FITTING, 6801-6-6				
44	2	04405	C-BALANCE CARTRIDGE, CB10-HV				
45	1	03290	SPACER WASHER, .532 X .750 X .125				

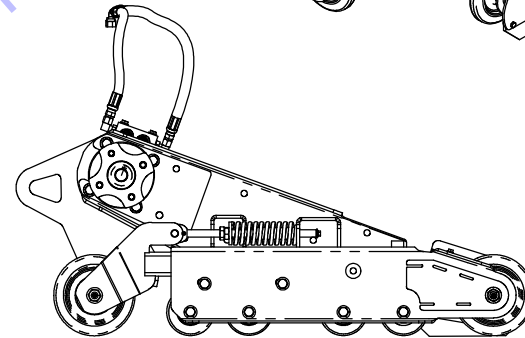
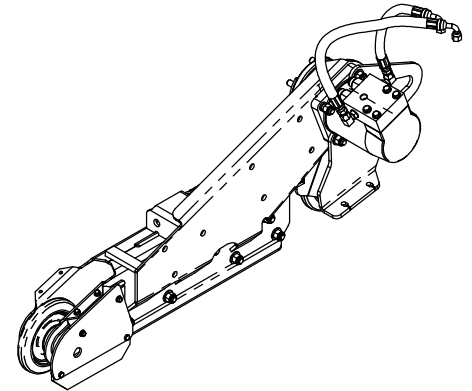
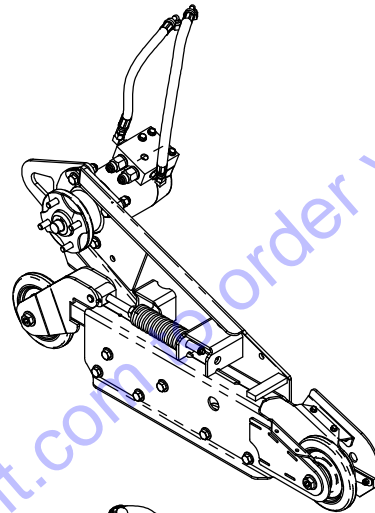

BARRETO

TITLE: RIGHT CARRIAGE

PRODUCT LINE: STUMP GRINDER

DATE: 7-12

SCALE: 1:16

SHEET 2 OF 2

DWG# 00334-SG

REF	QTY.	PART NO.	DESCRIPTION
1	1	10875	IDLER
2	2	03043	BALL BEARING, 6205
3	2	01026	SHIELD, OUTBOARD BEARING
4	2	10878	IDLER SPACER
5	2	05024	SNAP RING, HO-200, 2" INTERNAL
6	2	10887	O-RING, 2-020N70, 1 OD X 1/16 SECTION

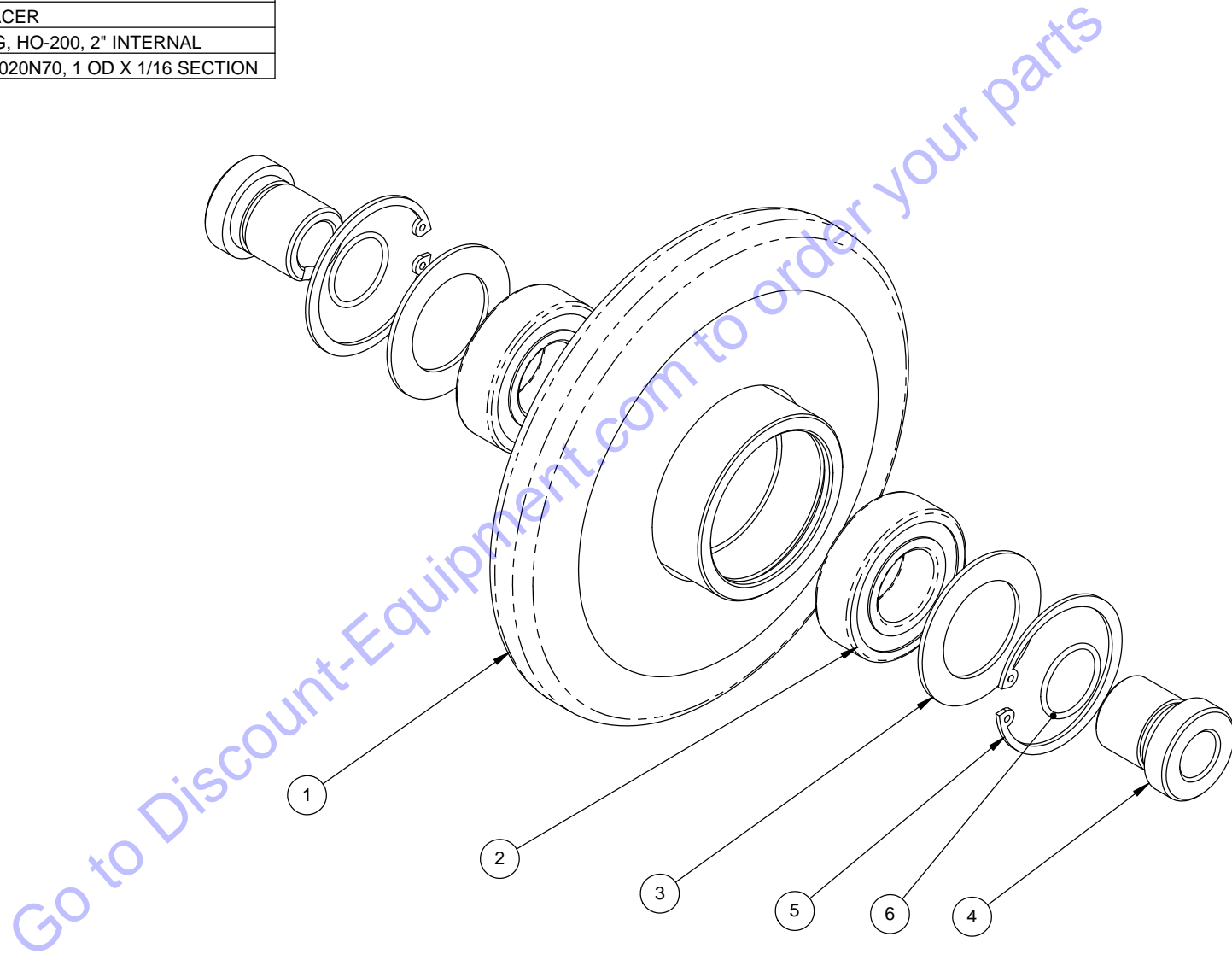

BARRETO

TITLE: IDLER ASSEMBLY

PRODUCT LINE: TRACK TRENCHER

DATE: 11/06

SCALE: 1:2

SHEET 1 OF 1

DWG# 00335

REF	QTY.	PART NO.	DESCRIPTION
1	1	11473	SUPPORT ROLLER
2	2	01039	SHIELD, ROLLER BEARING
3	1	03043	BALL BEARING, 6205
4	1	05024	SNAP RING, HO-200, 2" INTERNAL

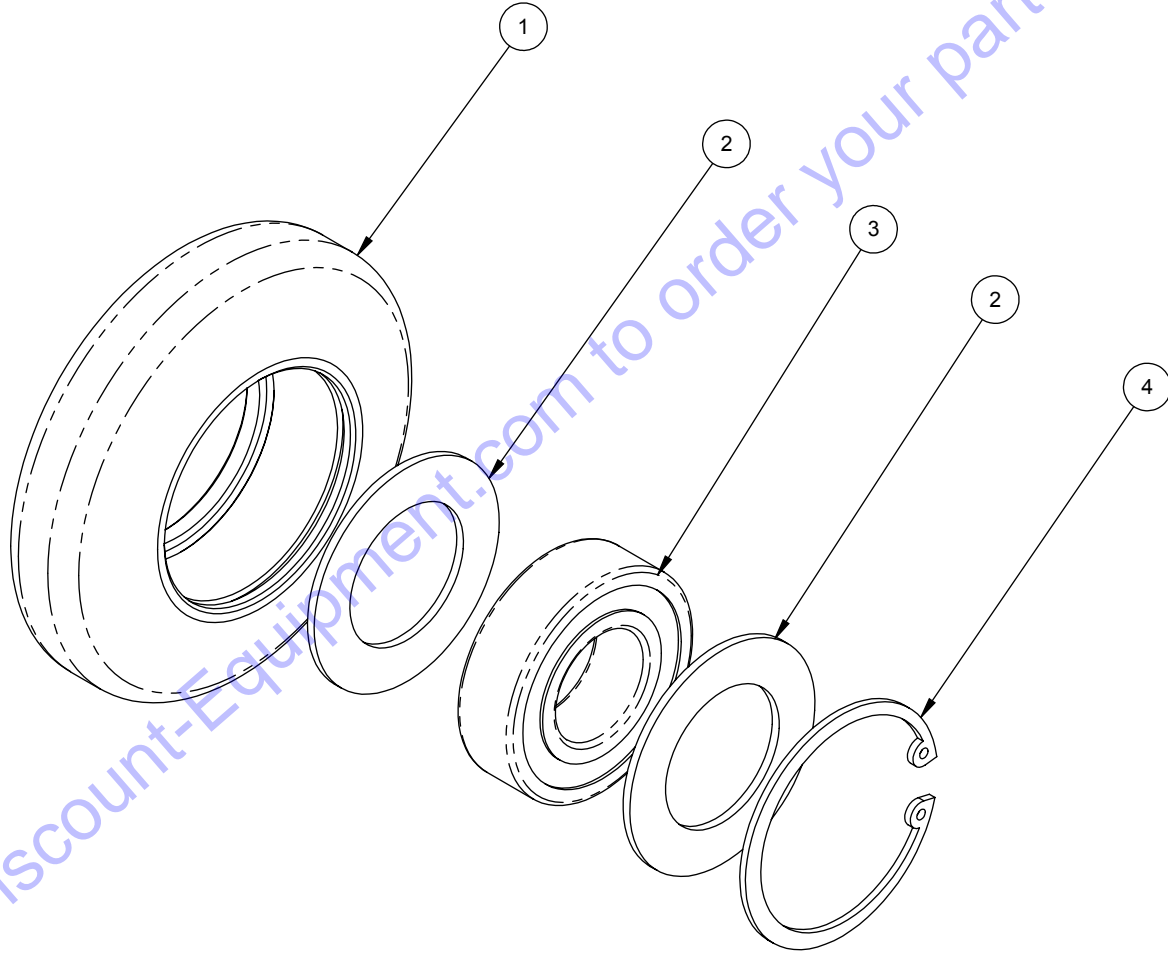

TITLE: MID ROLLER ASSEMBLY	
PRODUCT LINE: TRACK TRENCHER	DATE: 11/07
SCALE: 2:3	DWG# 00366
SHEET 1 OF 1	

TEM NO.	QTY.	PART NO.	DESCRIPTION
1	1	00605-B-SG	STUB SHAFT ASSEMBLY, BRIGGS
2	1	B&S-30	ENGINE, BRIGGS 31hp
3	1	07027-10	MUFFLER, B&S 31, CENTER EXIT
4	1	04021-C16	TANDEM PUMP, PNT-16+1.2, PARKER
5	1	12730	HYDRO PUMP, 10CC TANDEM
6	1	12809	MUFFLER SHIELD. BRIGGS
7	1	13228 R1	ENGINE BASE
8	2	13202	PUMP SUPPORT
9	2	12447T	EXTEND ARM
10	1	13229-L	BRACE MOUNT, LEFT
11	1	13229-R	BRACE MOUNT, RIGHT
12	2	13205	SQUARE NUT
13	1	02016	PUMP ADAPTER
14	1	12456	SPIDER, HYTREL, L-099
15	1	12454	JAW COUPLER, 1.125, L-099
16	1	12455	JAW COUPLER, 9T SAE A, L-099
17	1	05014	KEY, 1/4 X 1/4 X 3/4
18	1	12320	ENGINE DRAIN HOSE
19	1	12339 R2	HOSE, HYDROSTAT DRAIN
20	1	12715	SUMP HOSE, 1" X 4.3"
21	2	05225	CLAMP, 1" ID HOSE, CTB-35 ST
22	1	04215	FITTING, 9067-6-14 METRIC
23	1	04211	FITTING, 6801-8-10
24	1	04539	FITTING, 2408-6
25	1	11082	FITTING, 6801-6-6-L
26	1	10456	FITTING, 4603-16-12
27	1	11074	FITTING, 6802-6-6
28	1	11070	FITTING, 4601-8-6
29	4	04226	FITTING, 6400-6-8
30	4	05352	HH CAP SCREW, 3/8-16 NC X 2-1/4 G5 ZINC
31	12	05091	HH CAP SCREW, 3/8-16 NC X 1-1/4 G5 ZINC
32	6	05059	HH CAP SCREW, 3/8-16 NC X 1 G5 ZINC
33	4	05187	HHFS 3/8-16 X 3/4, G5, ZN
34	29	05101	WASHER, 3/8 SAE ZINC
35	10	05073	NUT, NYLOCK, 3/8-16 NC ZINC
36	2	05131	HHFS 5/16-18 X 3/4, G8, ZN
37	4	05247	HH CAP SCREW, 5/16-18 NC X 3/4 G5 ZINC
38	4	05273	NUT, NYLOCK, 5/16-18 NC ZINC
39	1	07027-21	WIRE GUARD
40	1	12047	FITTING, 6410-6-6

REPLACES 00390TT2-BS30

RELEASE DATE	6/17/16
REVISED DATE	11/14/16
REVISION #	1

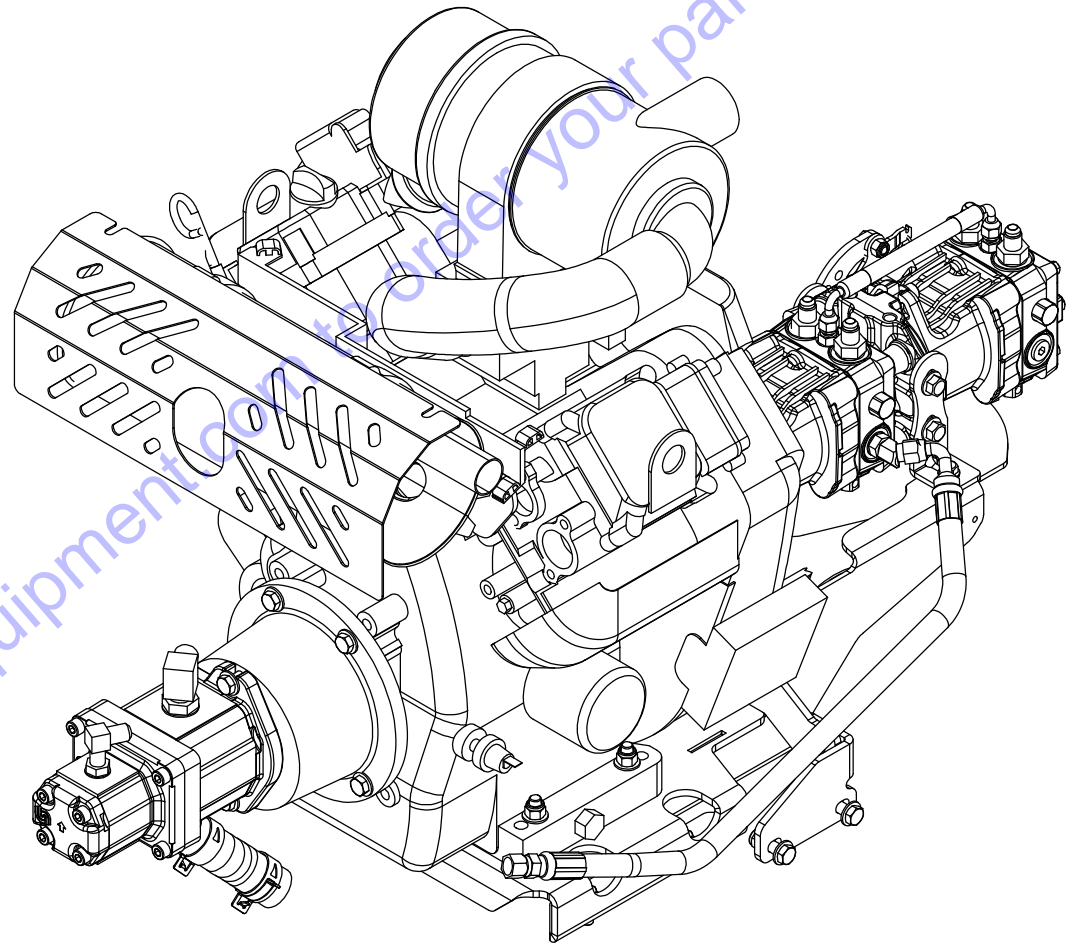

BARRETO

TITLE: ENGINE / PUMPS ASSEM.,B&S 30
 PRODUCT LINE:SG
 SCALE: 1:6
 SHEET 1 OF 2
 DWG# 00390-OBB-BS30

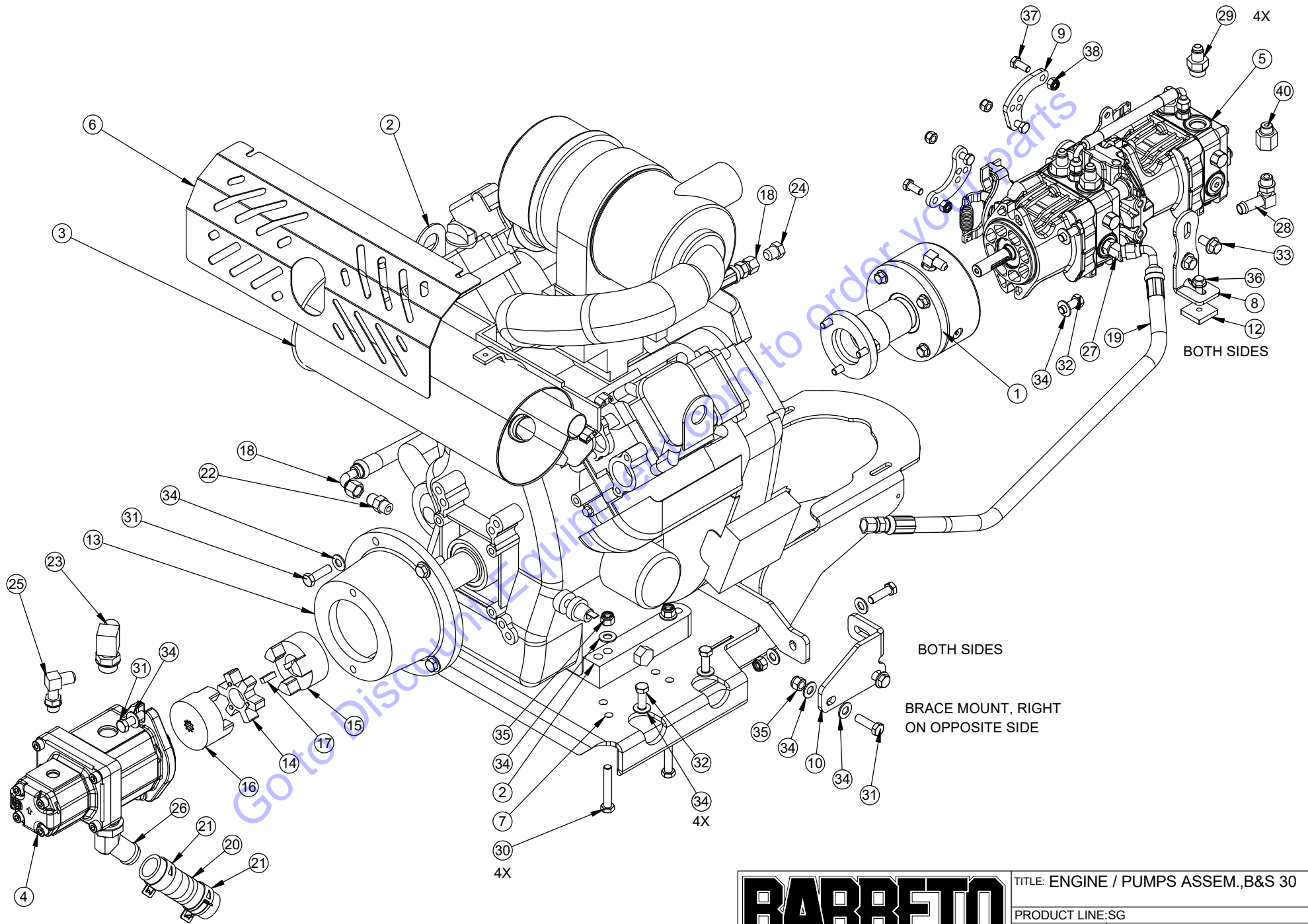

BARRETO

TITLE: ENGINE / PUMPS ASSEM.,B&S 30
 PRODUCT LINE:SG
 SCALE: 1:6
 SHEET 2 OF 2

DWG# 00390-OBB-BS30

ITEM NO.	QTY.	PART NO.	DESCRIPTION
1	1	03263N	FUEL TANK, "BARRETO"
2	4	05131	HH FLANGE SCREW, 5/16-18 NC X 3/4 G8 ZINC
3	2	05144	WHIZ-LOCK, 5/16-18 NC X 1 ZINC
4	1	03062-17	FITTING, 1/4 NPT-M TO 1/4 HOSE BIB, 45 EL
5	2	03062-06	CLAMP, 1/4" FUEL LINE
6	1	11563	FUEL HOSE
7	1	03062-12	FUEL TANK CAP, KELCH
8	1	11643	NUT BAR
9	1	11552F	TANK POCKET
10	2	05273	NUT, NYLOCK, 5/16-18 NC ZINC
11	1	03062-03	FUEL SHUT OFF VALVE

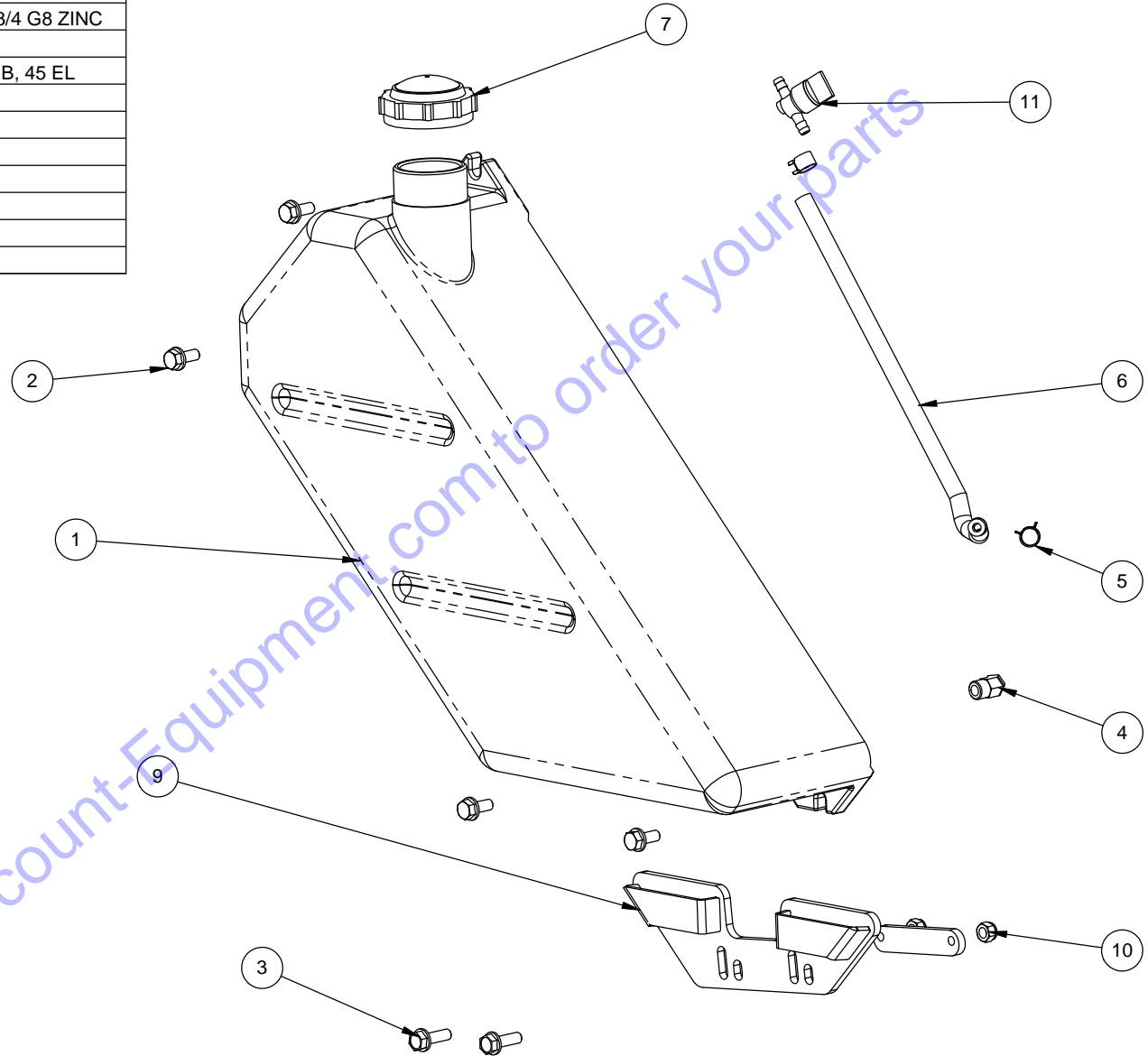

BARRETO

TITLE: FUEL TANK ASSEMBLY
 PRODUCT LINE: 30SG DATE: 9-9-13
 SCALE: 1:5 DWG# 00456-SG
 SHEET 1 OF 1

ITEM NO.	QTY.	PART NO.	DESCRIPTION
1	1	03508	SPEED KNOB
2	1	11709	PARK LEVER
3	2	05506	SNAP RING, 1/2" EXTERNAL, SH-50
4	2	10113	THRUST WASHER, .518 X .873 X .030
5	2	03501	BUSHING, IGUS MFI-0810-08
6	1	11708	ROLLER
7	1	11707	SPRING BASE
8	1	05138	HH FLANGE SCREW, 5/16-18 NC X 1-1/4 G8 ZINC
9	1	03354	SPRING, CENTURY 1539
10	1	10300	THRUST WASHER, .880 X 1.123 X .030, HARD
11	1	05602	SNAP RING, SH-87-P, 7/8" EXTERNAL
12	1	05143	SET SCREW .25 NF X .25 CUP
13	1	11705	BRAKE PIN
14	1	05131	HH FLANGE SCREW, 5/16-18 NC X 3/4 G8 ZINC
15	1	12355	CAM PLATE
16	1	05273	NUT, NYLOCK, 5/16-18 NC ZINC
17	1	04450-16	BRAKE DECAL

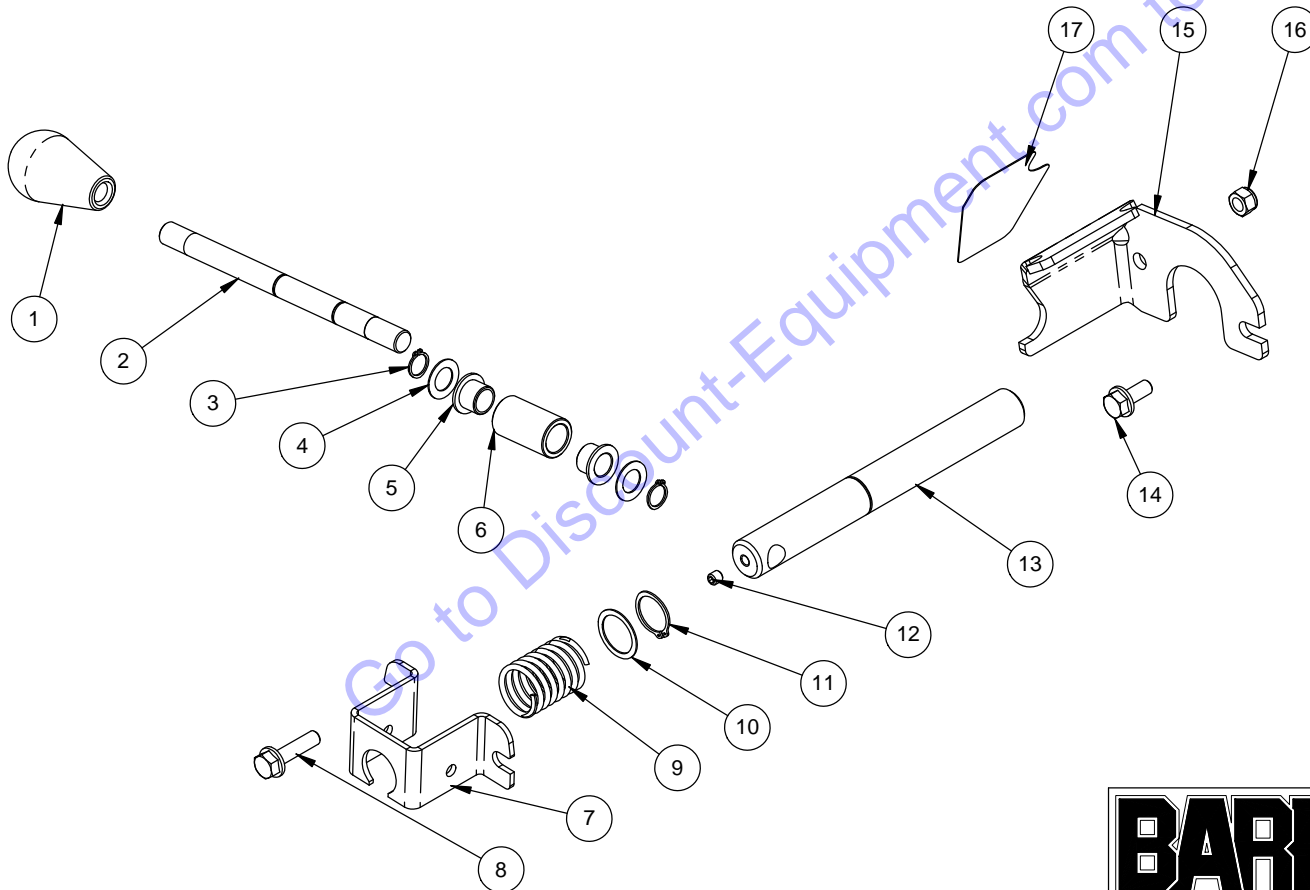
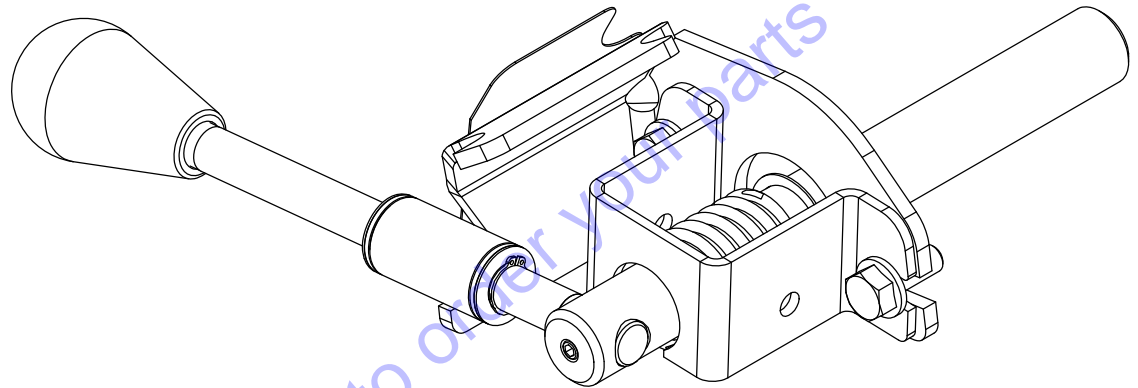

BARRETO

TITLE: PARK BRAKE ASSEMBLY

PRODUCT LINE: STUMP GRINDER DATE: 7-12

SCALE: 1:4
SHEET 1 OF 1

DWG# 00458-SG

ITEM NO.	QTY.	PART NO.	DESCRIPTION
1	1	12264	BEARING HOUSING
2	1	05044	GREASE ZERK, 1/4-28 UNF
3	1	05607	SNAP RING, SHR-156, 1-9/16" EXT, HEAVY
4	1	12382	BEARING, DOUBLE 5208 E-RS / 3208-RS
5	1	12266	BEARING SHIELD
6	1	05603	SNAP RING, HO-315, 3-5/32 INTERNAL
7	6	05355	NUT, GRIPCO, 7/16-20 NF G5 ZINC
8	1	12278	DRIVE STUB, SPLINED, 13T
9	1	12279	CUTTER WHEEL
10	16	12283	CUTTER BOLT, 2-1/4", LP-214
11	4	12281	STRAIGHT HOLDER, 700 LOPRO
12	16	05273	NUT, NYLOCK, 5/16-18 NC ZINC
13	15	12280E	TOOTH SPACER, 700 LOPRO
14	16	12280D	CUT TOOTH, 700 LOPRO GREEN
15	12	12282	ANGLED HOLDER, OUT, 700 LOPRO
16	1	12265	AXLE STUB
17	6	05354	HH CAP SCREW, 7/16-20 NF X 2 G8 ZINC
18	1	12383	BEARING INSERT YAR 207-107
19	1	12383	BEARING FLANGE FY 1.44 TM
20	1	11027	SHAFT WASHER
21	1	05067	HH CAP SCREW, 1/2-13 NC X 1 G5 ZINC
22	6	05544	WASHER, 7/16 SAE ZINC

180 FT-LB

25 FT-LB

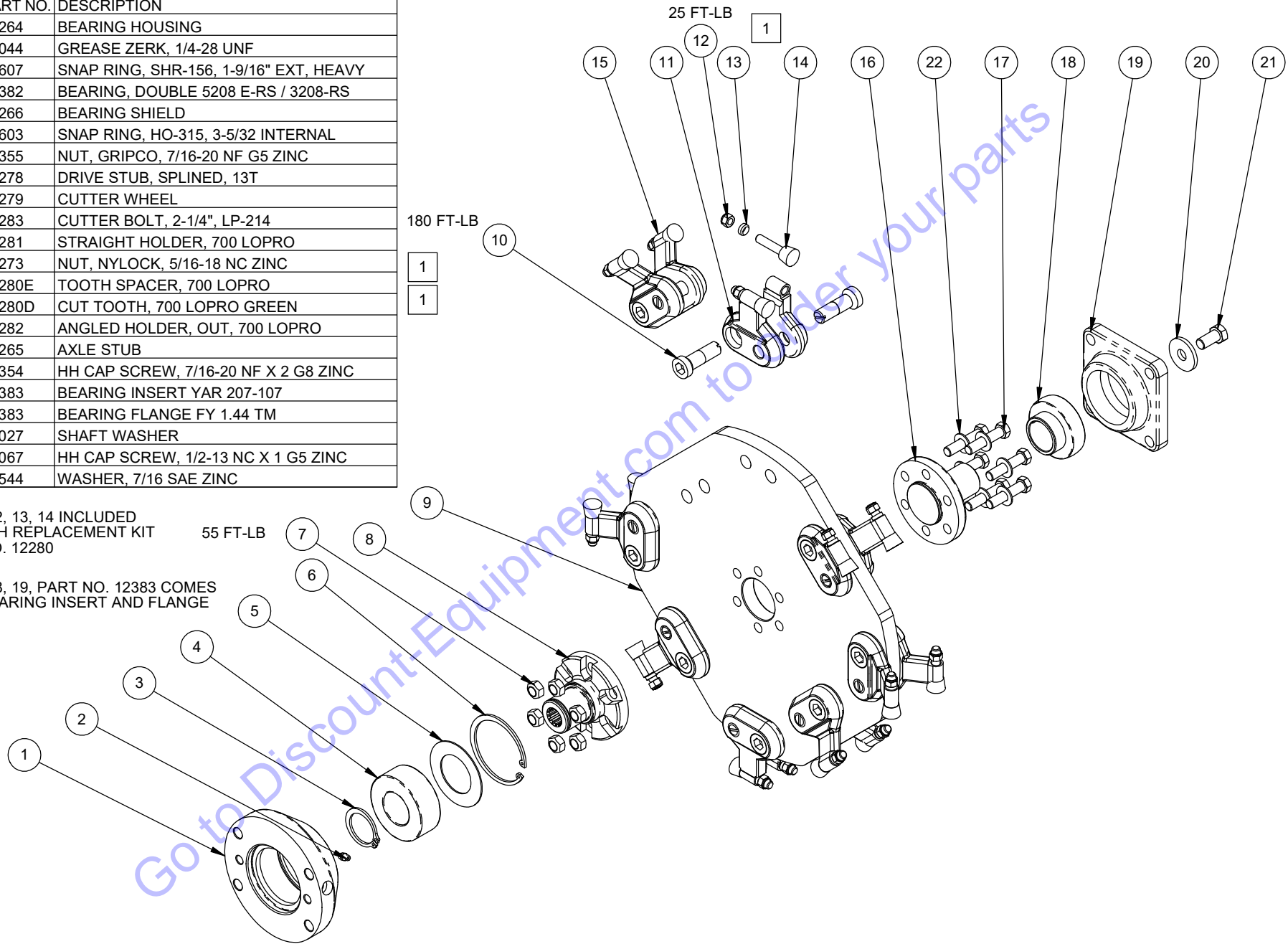

1 ITEMS 12, 13, 14 INCLUDED IN TOOTH REPLACEMENT KIT PART NO. 12280

55 FT-LB

2 ITEMS 18, 19, PART NO. 12383 COMES WITH BEARING INSERT AND FLANGE



TITLE: CUT WHEEL ASSY
 PRODUCT LINE: STUMP GRINDER DATE: 7/12
 SCALE: 1:6
 SHEET 1 OF 1 DWG# 00492

ITEM NO.	QTY.	PART NO.	DESCRIPTION
1	2	03302	FITTING, 6409-6 PLUG
2	1	04554	FITTING, 6801-8-8
3	3	05557	HH CAP SCREW, 1/4-20 NC X 1/2 G5 ZINC
4	1	04028	SOLENOID VALVE, SVP10-NOR
5	1	04028-01	SOLENOID COIL
6	1	12781	FITTING, 4604-12-10
7	1	04023	CP441-1 COUNTERBALANCE VALVE
8	1	03300	FITTING, 6409-4 PLUG
9	1	12313	GRINDER VALVE BODY
10	2	04520	FITTING, 6400-8-8
11	1	04024	RELIEF VALVE, CP200 3

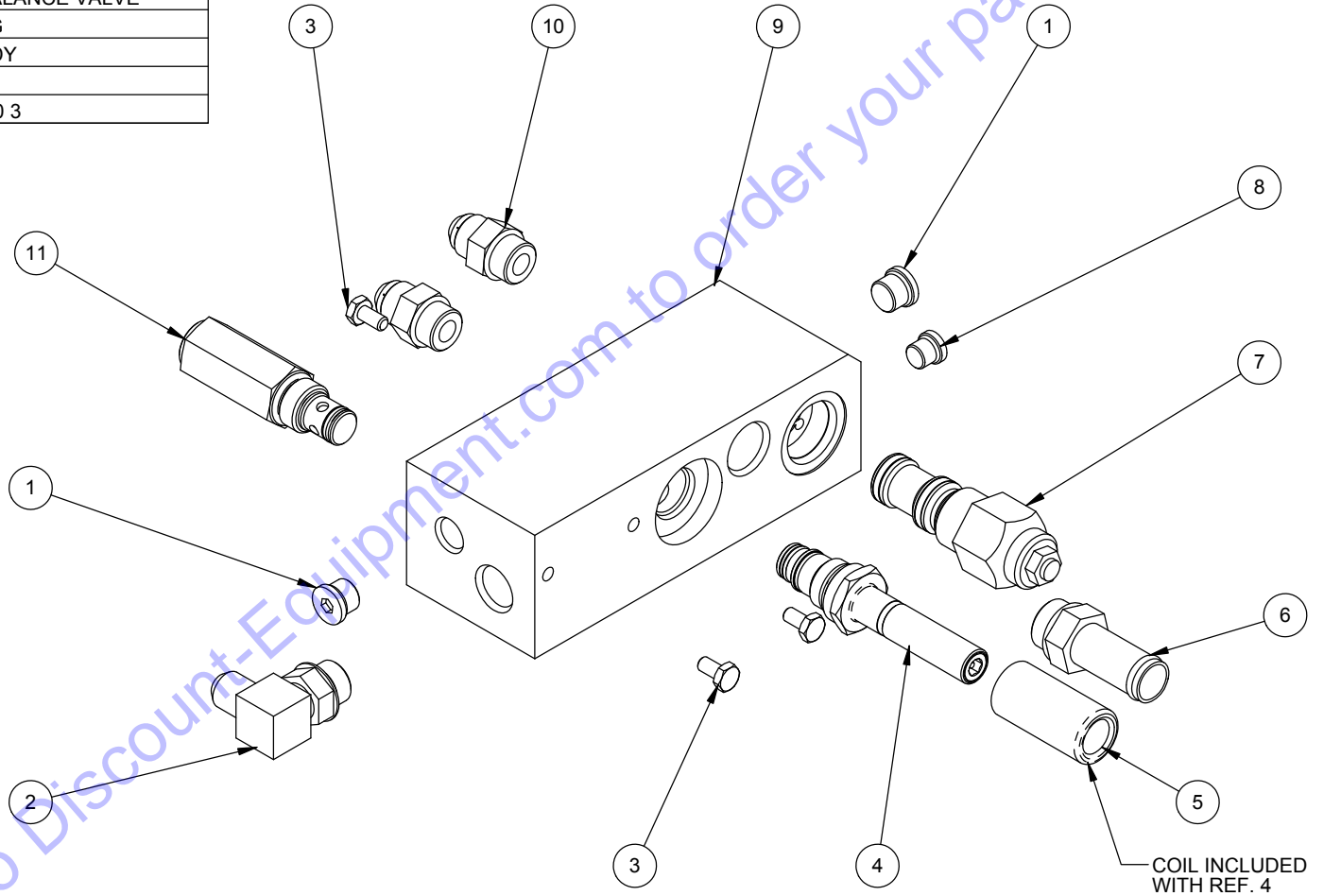

Go to Discount-Equipment.com to order your parts

BARRETO

TITLE: CUTTER VALVE FOR SG - SIDE VALVE / C. PIVOT	
PRODUCT LINE: 30SG / CP	DATE: 10/13
SCALE: 1:3	DWG# 00495-CP
SHEET 1 OF 1	

ITEM NO.	QTY.	PART NO.	DESCRIPTION	ITEM NO.	QTY.	PART NO.	DESCRIPTION
1	8	05557	HH CAP SCREW, 1/4-20 NC X 1/2 G5 ZINC	48	2	05111	BH SHOULDER SCREW, 3/8 X 3/8
2	1	12316	COOLER / FILTER MOUNT	49	6	05273	NUT, NYLOCK, 5/16-18 NC ZINC
3	1	12727	HOSE, GRINDER VALVE / FILTER 3/4	50	1	12462	BACK COVER
4	8	05081	WASHER, 1/4 SAE ZINC	51	3	05510	BUTTON HD SOCKET CAP SCR, 5/16-18 X 3/4
5	8	05008	CLAMP, 1" HOSE, CTB-29				
6	2	04202	FITTING, 4601-12-12				
7	1	04212-OR-TL	FILTER HEAD, #12 O-RING, TAP LEFT				
8	1	04555	FITTING, 6801-4-4				
9	6	05069	WHIZ LOCK, 1/4-20 NC X 5/8 ZINC				
10	1	11546	THERMO ADAPTER				
11	1	03225	O-RING, 2-116N70, 15-16 OD X 3/32 SECTION				
12	1	11545	THERMOSTAT VALVE BODY				
13	1	12463	TOP MOUNT				
14	2	05560	HH CAP SCREW, 1/4-20 NC X 2-1/4 G5 ZINC				
15	3	05359	CLIP NUT, 5/16-18				
16	1	03952	FILTER, HYDRAULIC OIL, WITH BY-PASS				
17	1	12335	HOSE, THERMO / JUNCTION, 3/4				
18	1	12334	HOSE, FILTER / COOLER, 3/4				
19	1	12464	TEMP SWITCH, ACT B4130FD607-P100				
20	1	11544	THERMOSTAT VALVE, CT 1731				
21	1	04523	FITTING, 4601-12-10				
22	1	10362	FITTING, 4603-12-12				
23	1	12336	HOSE, COOLER / JUNCTION, 3/4				
24	1	04219	FITTING, 4604-12-12				
25	1	04538	FITTING, 6801-6-6				
26	1	04572	FITTING, 4601-8-8				
27	1	12337	RETURN JUNCTION				
28	1	10456	FITTING, 4603-16-12				
29	2	12131	CLAMP, 1/2" HOSE, CTB-20				
30	1	12370	PUMP FEED, LEFT				
31	1	12356	RETURN HOSE, 1"				
32	2	05225	CLAMP, 1" ID HOSE, CTB-35 ST				
33	1	12460	FAN SHROUD				
34	4	05193	RUBBER GROMMET, .62 X .38				
35	4	11741	SPACER				
36	10	05096	NUT, NYLOCK, 1/4-20 NC ZINC				
37	4	05191	SCREW #12-24 X 1/2 PPH				
38	1	04033	FAN, 7.5" PULLER				
39	4	05190	NUT, NYLOCK, 12-24 NC ZINC				
40	4	05535	WHIZ LOCK, 1/4-20 NC X 7/8 ZINC				
41	4	05101	WASHER, 3/8 SAE ZINC				
42	2	04227	FITTING, 4501-12-8				
43	1	11533	OIL COOLER, B&M 70266				
44	4	05567	HH FLANGE SCREW, 5/16-18 NC X 1" G8 ZINC				
45	4	05068-HDN	WASHER, 5/16 HARDENED ZINC				
46	1	12315-OB	COOLER BRACKET				
47	1	12461	COVER MOUNT				

RELEASE DATE	6/21/16
REVISED DATE	5/22/17
REVISION #	1

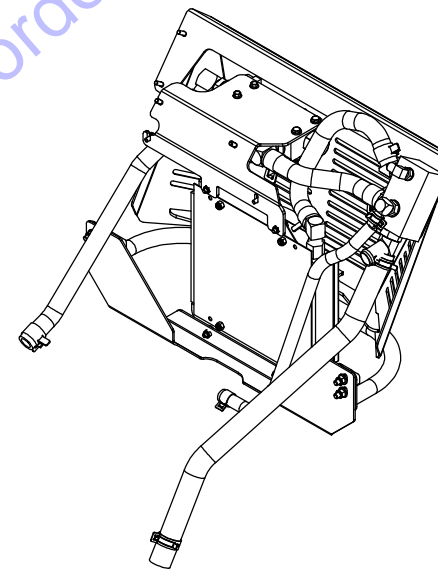

BARRETO	TITLE: COOLER ASSEMBLY	
	PRODUCT LINE: 30 SG	
	SCALE: 1:12 SHEET 1 OF 2	DWG# 00496-OB

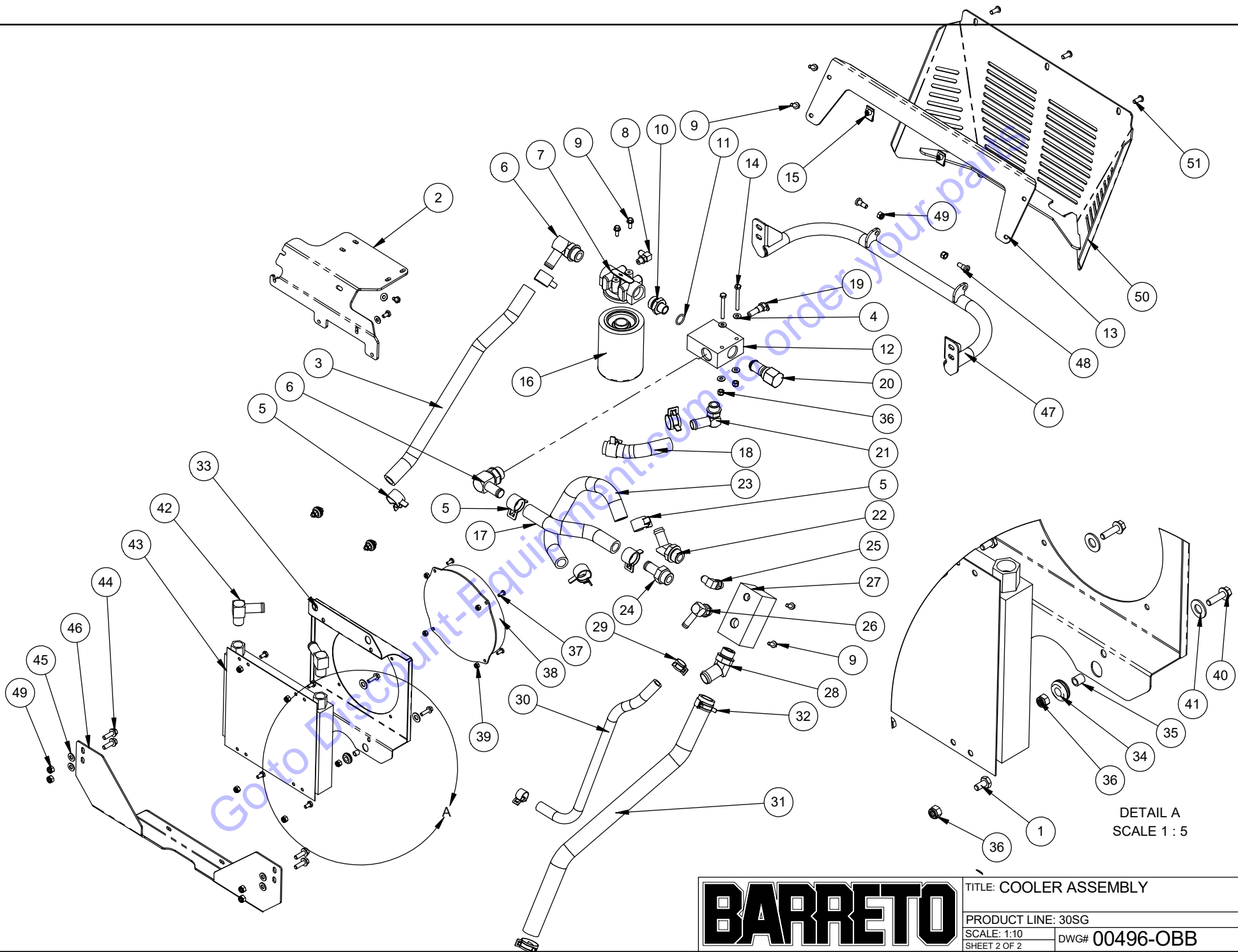

DETAIL A
SCALE 1 : 5

BARRETO

TITLE: COOLER ASSEMBLY
 PRODUCT LINE: 30SG
 SCALE: 1:10
 SHEET 2 OF 2
 DWG# 00496-0BB

TEM NO.	QTY.	PART NO.	DESCRIPTION
1	1	00497	CYLINDER VALVE ASSEM
2	1	00456-SG	FUEL TANK ASSEMBLY
3	1	00496-0BB	COOLER ASSEMBLY
4	1	12288T	CONTROL TOWER
5	1	13326	HAND REST
6	1	12311 R1	SPEED LEVER, LEFT
7	1	12312T R1	SPEED LEVER, RIGHT
8	1	12314-T	FRONT COVER
9	1	12775	LEFT HAND REST
10	2	12330	SPEED LINK, TOP
11	1	12331	SPEED LINK, LOWER, LEFT
12	1	12457T	SPEED LINK, LOWER RT
13	1	12332T	CONTROL PANEL
14	1	11627K	IGNITION SWITCH PLATE
15	1	07024-E1	IGNITION SWITCH, KOHLER ONLY
16	1	03009-R1	HOUR METER, WITH FLASH ALERT
17	1	12313D	CUTTER VALVE
18	4	12381	IGUS FLANGE JFL-20
19	1	03515-T	THROTTLE CABLE
20	1	07027-08	FUSE / RELAY HOLDER ASSEM
21	1	12090	INSTRUCTION CANISTER
22	1	12371T	HOSE, PUMP / CYLINDER VALVE
23	1	12340T	HOSE, CYLINDER VALVE - RETURN JCT
24	1	12723	HOSE, RT. A / LEFT SWING TEE
25	1	12724	HOSE, RT B / RT SWING TEE
26	1	12725	HOSE, LEFT B / LIFT ROD
27	1	12726	HOSE, LEFT A / LIFT PISTON
28	1	04554	FITTING, 6801-8-8
29	2	04520	FITTING, 6400-8-8
30	1	04451-TK	L - R TRACK DECAL
31	1	03341-07	DECAL, "IGNITION OFF/ON"
32	1	04440-05	DECAL, "THROTTLE CONTROL"
33	1	04451-CP-03	DECAL, CUTTER CONTROL
34	1	03040-02	DECAL, "BARRETO", 3-1/2 X 11-1/4
35	4	05292	HH CAP SCREW, 3/8-24 NF X 1-1/4 G5 ZINC
36	4	05056	HH CAP SCREW, 3/8-24 NF X 1 G5 ZINC
37	4	05351	SH SHOULDER SCREW, 3/8 X 1/4 x 5/16-18
38	8	05101	WASHER, 3/8 SAE ZINC
39	8	05073	NUT, NYLOCK, 3/8-16 NC ZINC
40	3	05175	HH CAP SCREW, 5/16-18 NC X 2-1/4 G5 ZINC
41	5	05273	NUT, NYLOCK, 5/16-18 NC ZINC
42	2	05002	NUT, GRIPCO, 5/16-18 NC G5 ZINC
43	13	05069	WHIZ-LOCK 1/4 - 20 X 5/8
44	12	05507	BUTTON HD SOCKET CAP SCR, 1/4-20 X 1/2
45	4	05557	HH CAP SCREW, 1/4-20 NC X 1/2 G5 ZINC
46	12	05081	WASHER, 1/4 SAE ZINC
47	6	05365	CLIP NUT, 1/4-20

TEM NO.	QTY.	PART NO.	DESCRIPTION
48	10	05096	NUT, NYLOCK, 1/4-20 NC ZINC
49	4	05233	SCREW #10-24 X 1/2 PPH

RELEASE DATE	6/20/16
REVISED DATE	NEW
REVISION #	0

REPLACES 00498T

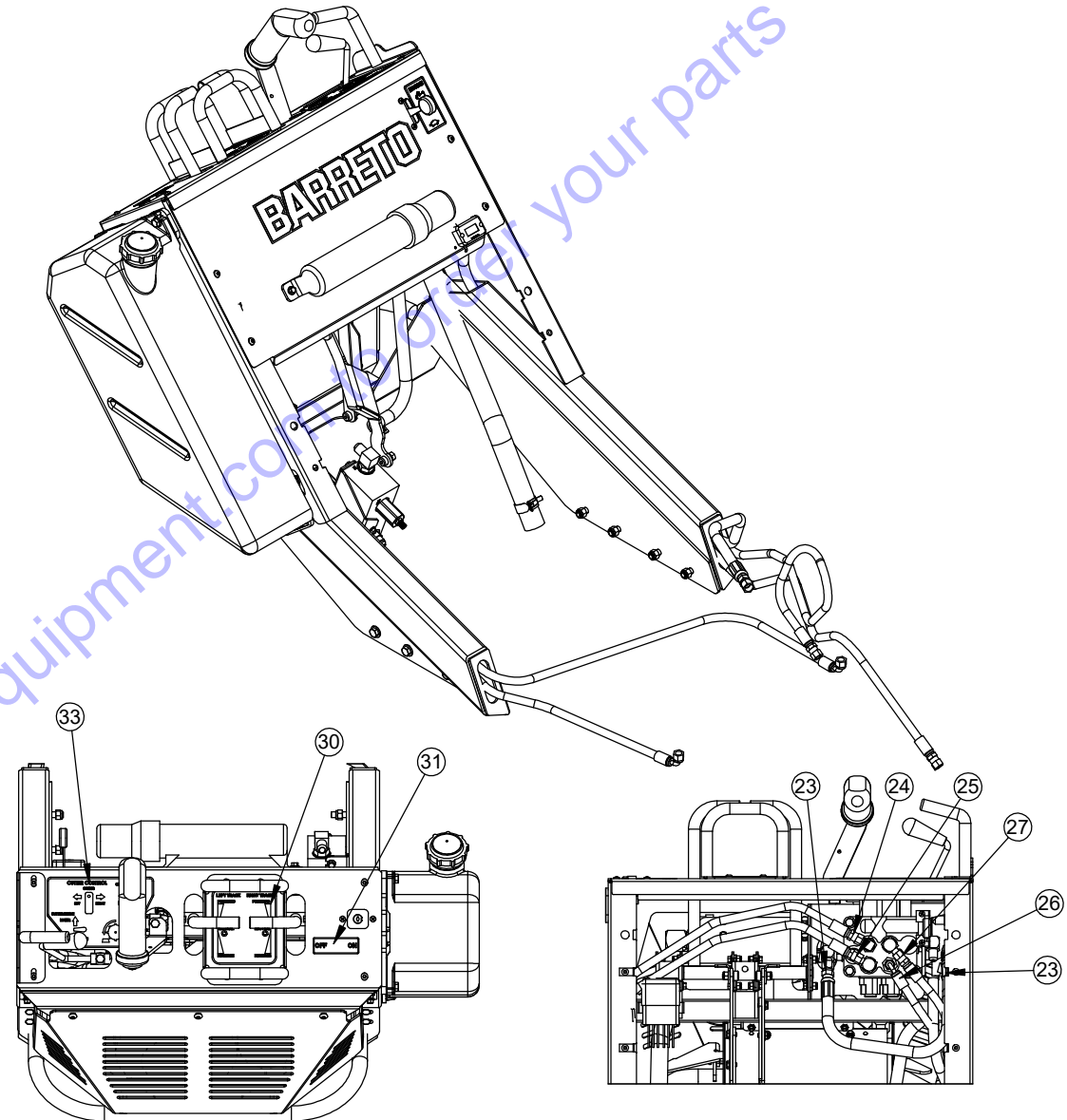

BARRETO

TITLE: CONTROL ASSEMBLY

PRODUCT LINE:SG

SCALE: 1:12

SHEET 1 OF 2

DWG# 00498-0BB

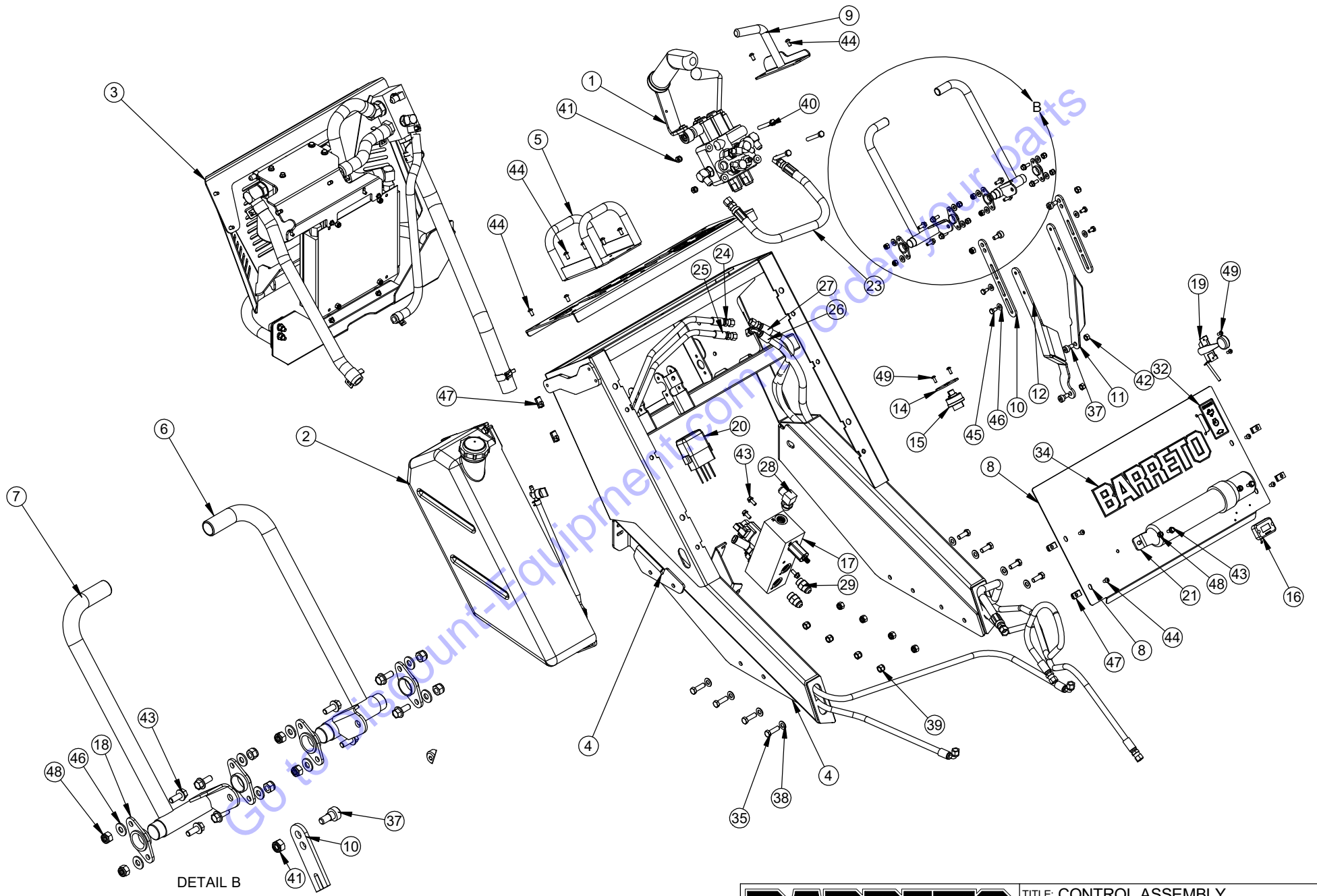

DETAIL B
SCALE 1 : 6

BARRETO

TITLE: CONTROL ASSEMBLY

PRODUCT LINE: SG

SCALE: 1:12

SHEET 2 OF 2

DWG# 00498-0BB

ITEM NO.	QTY.	PART NO.	DESCRIPTION
1	1	04022-W	VALVE, WOLVERINE
2	1	12776	LIFT LEVER
3	1	12777	SWING LEVER
4	1	12379-B1	JOYSTICK HANDLE, W/ TRIGGER
5	1	03542	SPEED KNOB
6	1	04529	FITTING, 6410-8-6
7	1	04527-01	FITTING, 6801-4-6
8	2	10403	FITTING, 6801-4-8
9	1	04568	FITTING, 6400-4-8
10	2	10404	FITTING, 6801-6-8
11	1	12466	HH CAP SCREW, M10-1.5 X 16mm, 8.8, ZINC
12	1	12782	HH CAP SCREW, M8-1.25 X 20MM ZINC
13	1	05406	HH CAP SCREW, M8-1.25 X 16MM ZINC

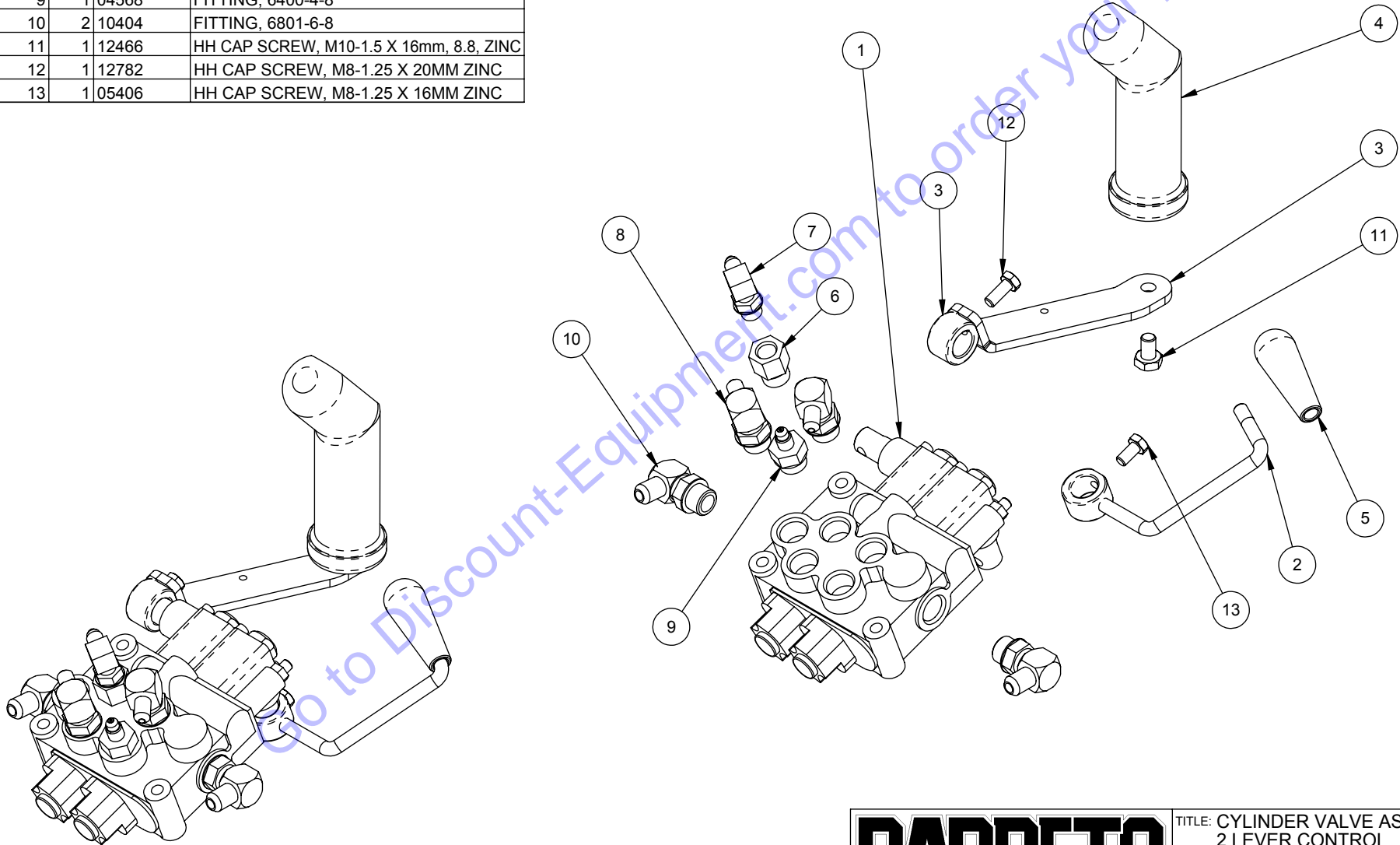

BARRETO

TITLE: CYLINDER VALVE ASSEM
 2 LEVER CONTROL
 PRODUCT LINE: 30SG, 35SG DATE: 2-14
 SCALE: 1:4
 SHEET 1 OF 1 DWG# 00497

ITEM NO.	QTY.	PART NO.	DESCRIPTION
1	1	12720 R1	LID, STUMP GRINDER
2	1	12720K R1	LID, STUMP GRINDER, FOR KHOLER ENGINE
3	1	12484	FITTING, 4603-16-16
4	1	10636	SUMP SCREEN, W/ O-RING 03292
5	1	03292	O-RING, 3-924N90, -24 FITTINGS
6	1	04555	FITTING, 6801-4-4
7	1	04538	FITTING, 6801-6-6
8	1	12864	RETURN TUBE
9	1	10526	FITTING, 6409-12 PLUG
10	1	03040-06	DECAL, "HYDRAULIC OIL ONLY"
11	6	05069	WHIZ LOCK, 1/4-20 NC X 5/8 ZINC

① USE LID 12720K FOR KOHLER POWERED MACHINE ONLY

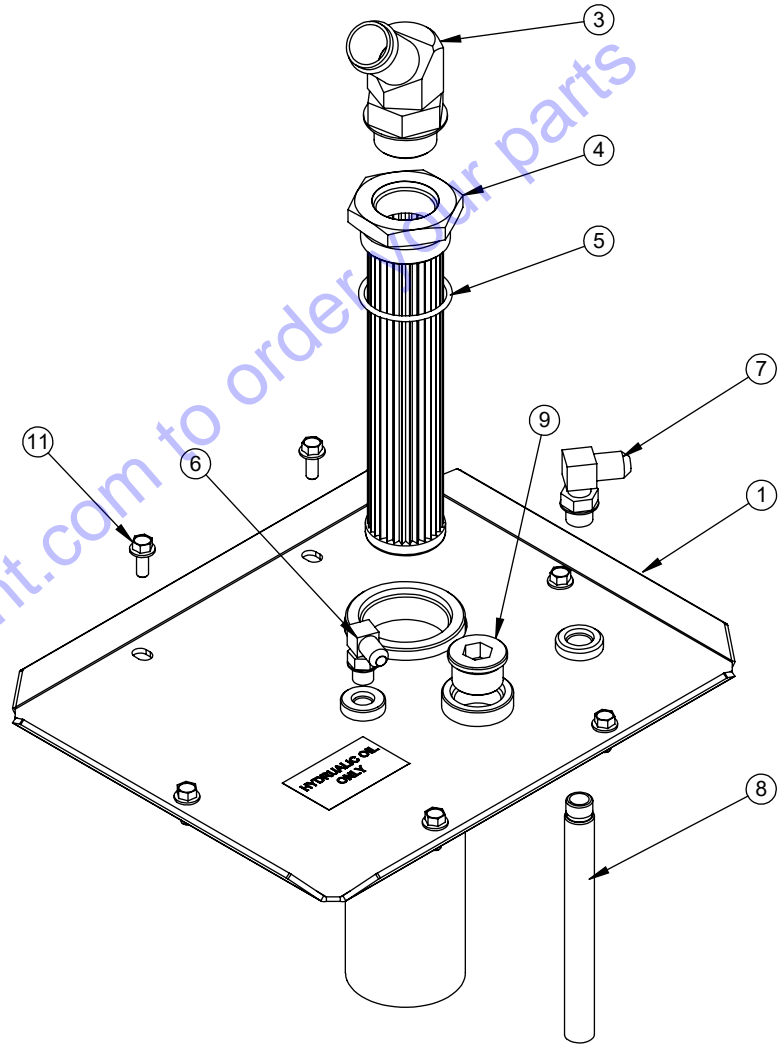
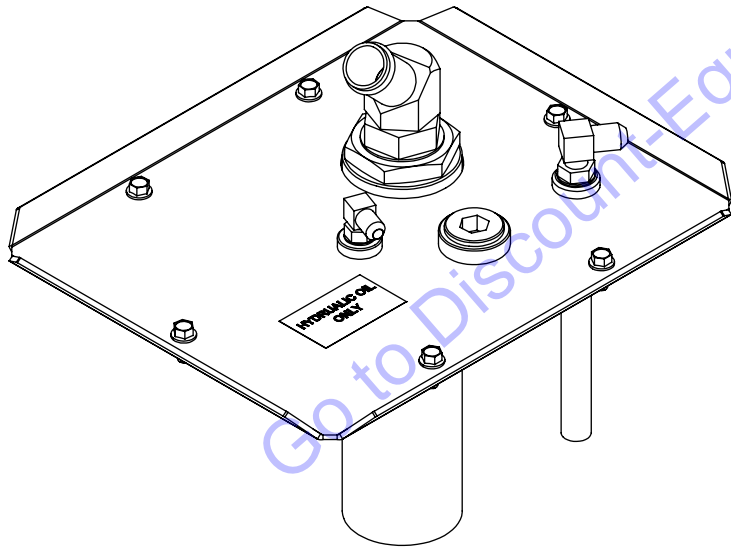

BARRETO

TITLE: LID ASSEMBLY
 SG - 10cc / CP
 PRODUCT LINE: 30SG DATE: 10/13
 SCALE: 1:4
 SHEET 1 OF 1 DWG# 00499CP

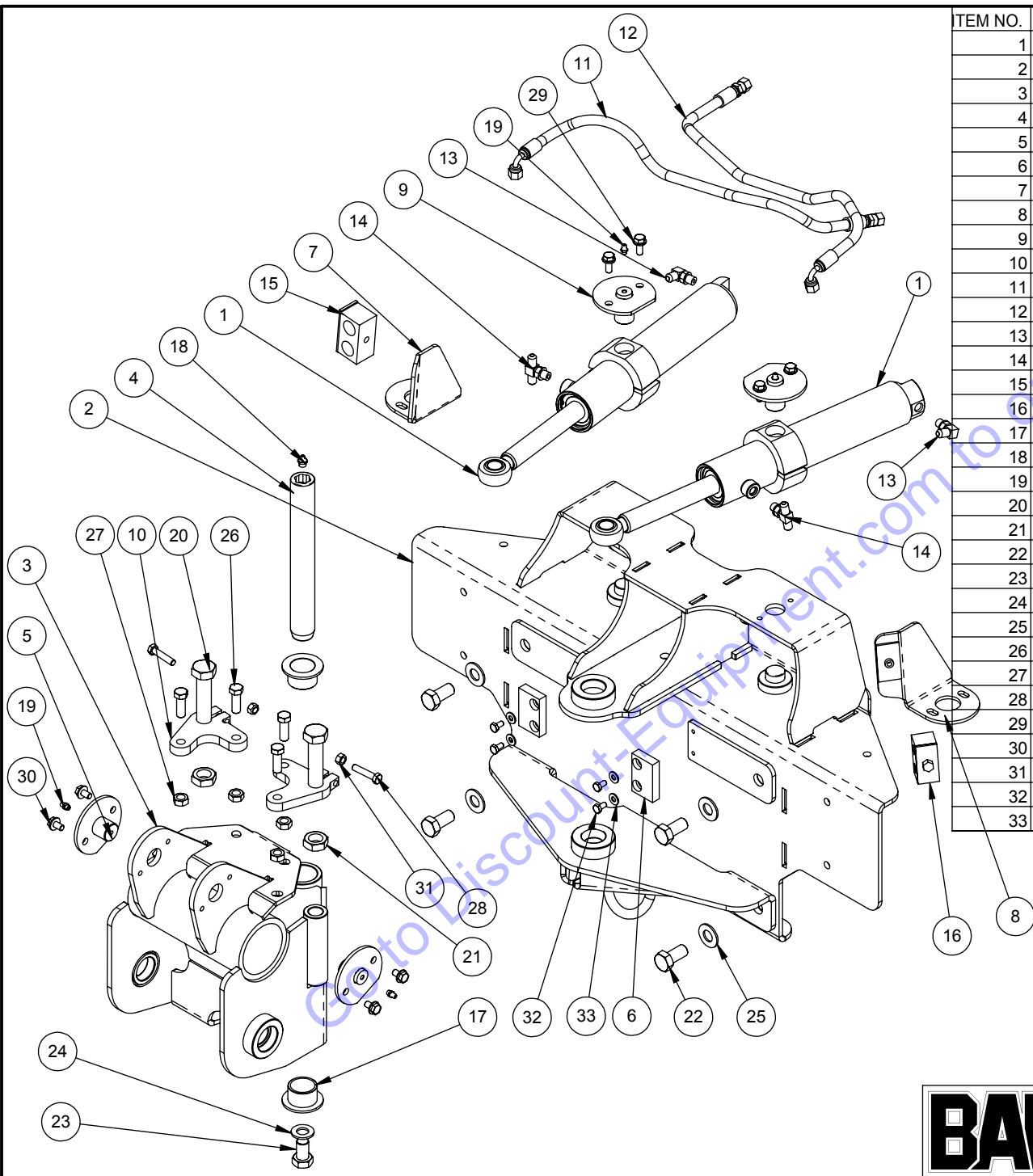

ITEM NO.	QTY.	PART NO.	DESCRIPTION
1	2	00538	SWING CYLINDER ASSEMBLY
2	1	12705	MOUNT BASE, CP
3	1	12706	PIVOT HEAD, CP
4	1	12711	SWING PIN
5	2	10281	CYLINDER PIN
6	2	12714	SWING STOP
7	1	12728R	HOSE MOUNT, RT
8	1	12728L	HOSE MOUNT, LEFT
9	2	12262	TRUNION PIN
10	2	12794	PIN BRACE
11	1	12722	HOSE, SWING CROSSOVER, R, FRONT
12	1	12722	HOSE, SWING CROSSOVER, L, FRONT
13	2	04555	FITTING, 6801-4-4
14	2	04223	FITTING, 6803-4-4-4
15	1	11656	TUBE CLAMP
16	1	12359	HOSE CLAMP, 1/4"
17	2	12712	BUSHING, COMPOSITE, 1.265 X 1.514 X 1.0, FLANGE
18	1	05256	GREASE ZERK, 1/8 NPT
19	4	05044	GREASE ZERK, 1/4-28 UNF
20	2	05179	HH CAP SCREW, 3/4-16 NF X 3-1/2 G8 ZINC
21	2	05115	NUT, JAM, 3/4-16 NF ZINC
22	4	05260	HH CAP SCREW, 5/8-11 NC X 1-1/4 G5 ZINC
23	1	05178	HH CAP SCREW, 5/8-18 NF X 1 G5 ZINC
24	1	05100-B	WASHER, M 16 X 30
25	4	05272	WASHER, 5/8 SAE ZINC HARDENED
26	4	05063	HH CAP SCREW, 7/16-20 NF X 1-1/4 G8 ZINC
27	4	05355	NUT, GRIPCO, 7/16-20 NF G5 ZINC
28	2	05420	HH CAP SCREW, 5/16-18 NC X 1-1/2 G5 ZINC
29	4	05131	HH FLANGE SCREW, 5/16-18 NC X 3/4 G8 ZINC
30	4	05169	WHIZ-LOCK 5/16 - 18 X 1/2
31	2	10462	NUT, GRIPCO, 5/16-24 NF G5 ZINC
32	4	05557	HH CAP SCREW, 1/4-20 NC X 1/2 G5 ZINC
33	4	05081	WASHER, 1/4 SAE ZINC

BARRETO

TITLE: PIVOT HEAD
 SG - CENTER PIVOT
 PRODUCT LINE: 30SG - CP, 35SG DATE: 10/13
 SCALE: 1:8
 SHEET 1 OF 1

DWG# 00535

ITEM NO.	QTY.	PART NO.	DESCRIPTION	ITEM NO.	QTY.	PART NO.	DESCRIPTION
1	1	02701	CYLINDER ROD	14	1	04555	FITTING, 6801-4-4
2	1	03232	O-RING, 2-014, 5/8 OD X 1/16 SECTION	15	1	02616	CYLINDER ROD END
3	1	02612	PISTON	16	1	05044	GREASE ZERK, 1/4-28 UNF
4	2	03237	BACK-UP RING, 8-330N90 PARBAK	17	1	04560	FITTING, 6400-4-4
5	1	03236	O-RING, 2-330, 2-1/2 OD X 3/16 SECTION	18	1	05251	HH CAP SCREW, 1/2-20 NF X 2 G5 ZINC
6	1	02613	CYLINDER END	19	1	05076	NUT, GRIPCO, 1/2-20 NF G5 ZINC
7	1	03234	O-RING, 2-228, 2-1/2 OD X 1/8 SECTION	20	1	03502	BUSHING, CONNEX 1.5X1.25X1
8	1	05102	WASHER, 1/2 SAE ZINC HARDENED				
9	1	05046	NUT, GRIPCO, 1/2-13 NC G5 ZINC				
10	1	03259	SEAL, 1x1/8x1/8 ROD				
11	1	03255	WIPER, 1 X 1-1/2 X 5/16 J-1000				
12	1	05211	SNAP RING, HO-256, 2-9/16 INTERNAL ZINC				
13	1	10704	CYLINDER, 2.50 X 9.43" STROKE				

1 5-5-16 CHANGE TO STEEL BUSHING

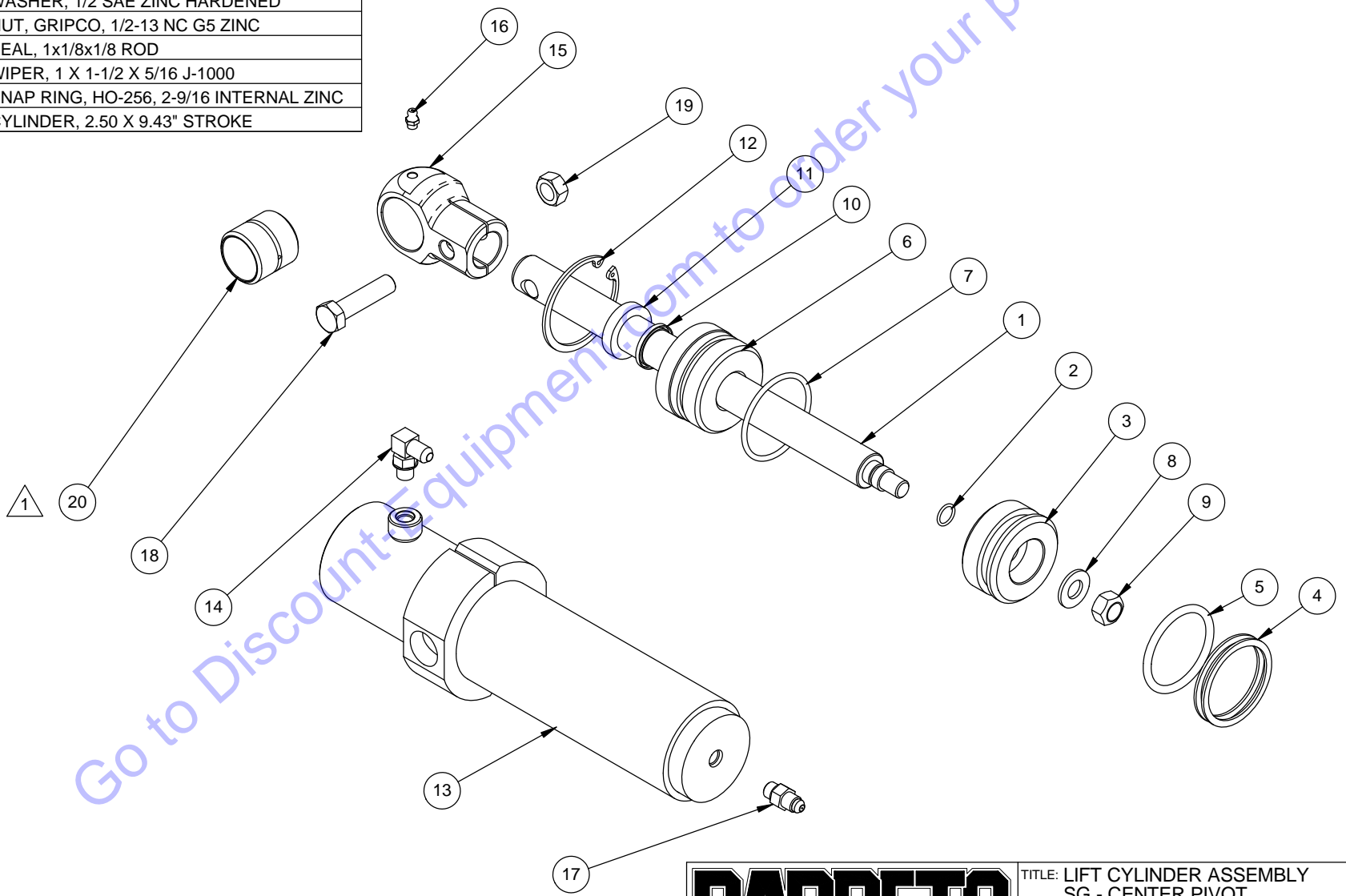

Go to DiscountEquipment.com to order your parts

BARRETO	TITLE: LIFT CYLINDER ASSEMBLY SG - CENTER PIVOT	
	PRODUCT LINE: 30SG - CP	DATE: 10/13
	SCALE: 1:4 SHEET 1 OF 1	DWG# 00537

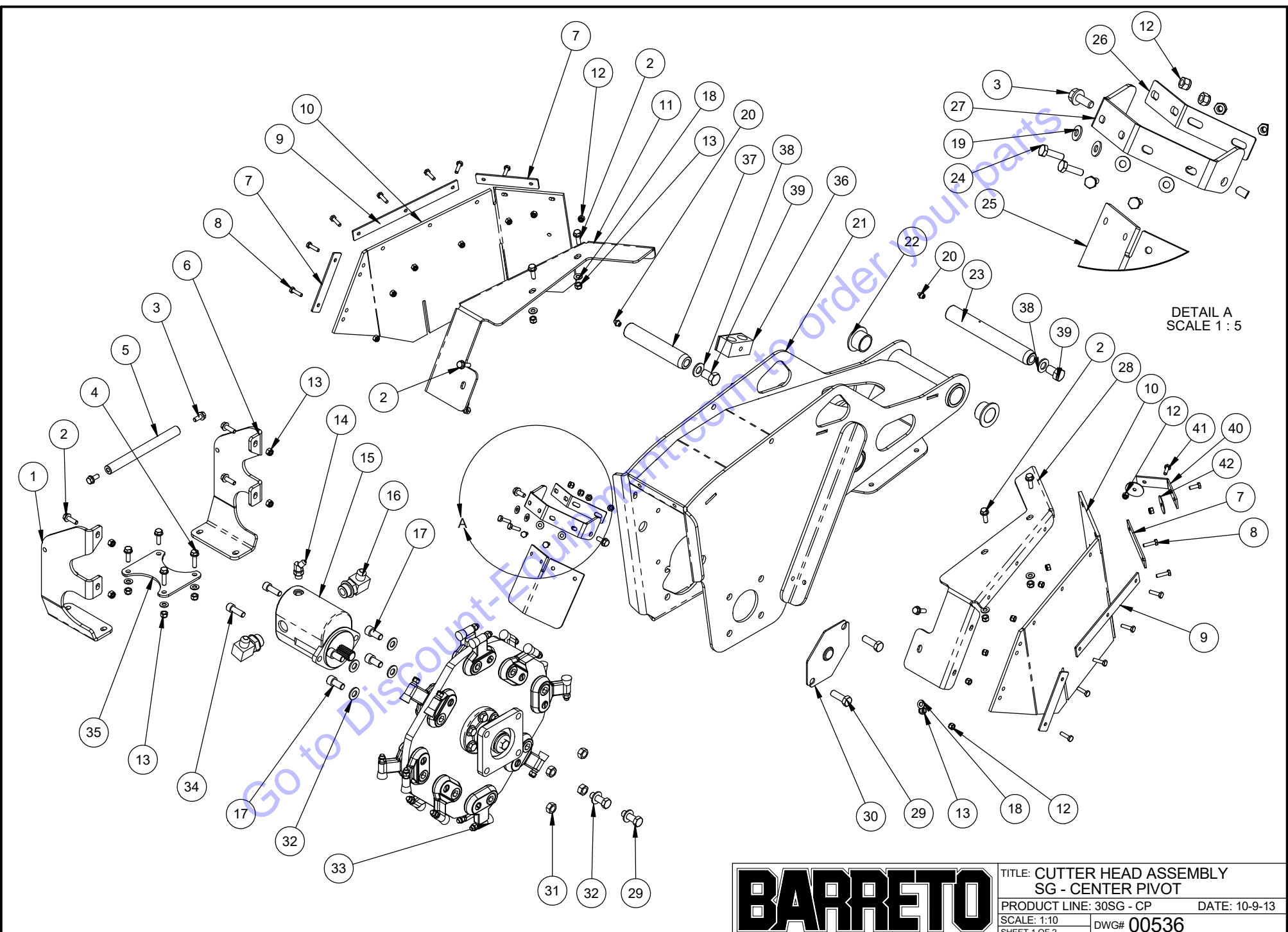

DETAIL A
SCALE 1 : 5

BARRETO

TITLE: CUTTER HEAD ASSEMBLY SG - CENTER PIVOT	
PRODUCT LINE: 30SG - CP	DATE: 10-9-13
SCALE: 1:10	DWG# 00536
SHEET 1 OF 2	

ITEM NO.	QTY.	PART NO.	DESCRIPTION	ITEM NO.	QTY.	PART NO.	DESCRIPTION
1	1	12270CP	MOTOR GUARD	25	1	12478	FRONT FLAP
2	12	05567	HH FLANGE SCREW, 5/16-18 NC X 1" G8 ZINC	26	1	12479 R1	FRONT FLAP KEEPER
3	4	05131	HH FLANGE SCREW, 5/16-18 NC X 3/4 G8 ZINC	27	1	12477	FRONT FLAP MOUNT
4	2	05138	HH FLANGE SCREW, 5/16-18 NC X 1-1/4 G8 ZINC	28	1	12716L	SKIRT MOUNT, LEFT
5	1	12269	GUARD BRACE	29	4	05300-01	HH CAP SCREW, 1/2-13 NC X 1-1/2 G5 ZINC
6	1	12270CP-L	MOTOR GUARD, LEFT	30	1	12267	BEARING COVER
7	4	12482	FLAP KEEPER	31	4	05046	NUT, GRIPCO, 1/2-13 NC G5 ZINC
8	14	05237	HH CAP SCREW, 1/4-20 NC X 1 G5 ZINC	32	6	05102	WASHER, 1/2 SAE ZINC HARDENED
9	2	12276	LEFT FLAP STRAP	33	1	00492	CUT WHEEL ASSY
10	2	12721	SKIRT	34	2	05353	SH CAP SCREW, 7/16-20 NF X 1-1/4 ZINC
11	1	12716R	SKIRT MOUNT, RIGHT	35	1	12710	GUARD BRACE
12	20	05096	NUT, NYLOCK, 1/4-20 NC ZINC	36	1	11656	TUBE CLAMP
13	16	05273	NUT, NYLOCK, 5/16-18 NC ZINC	37	1	12709T	LIFT ROD PIN
14	1	04218-1	FITTING, 6802-4-6	38	2	05100-B	WASHER, M 16 X 30
15	1	04030	GEAR MOTOR, 41cc	39	2	05178	HH CAP SCREW, 5/8-18 NF X 1 G5 ZINC
16	2	11038	FITTING, 6801-8-12	40	1	12778	FLAP TIE
17	4	05569	SH CAP SCREW, 1/2-13 NC X 1 ZINC	41	2	05554	HH CAP SCREW, 1/4-20 NC X 3/4 G5 ZINC
18	10	05068	WASHER, 5/16 SAE ZINC	42	2	05542	WASHER, 1/4 X 1 1/2 ZN
19	4	05081	WASHER, 1/4 SAE ZINC				
20	2	05256	GREASE ZERK, 1/8 NPT				
21	1	12707	CUTTER HEAD, CENTER PIVOT				
22	2	12712	BUSHING, COMPOSITE FLANGE				
23	1	12771	LIFT PIVOT PIN				
24	4	05535	HH CAP SCREW, 1/4-20 NC X 7/8 G5 ZN				

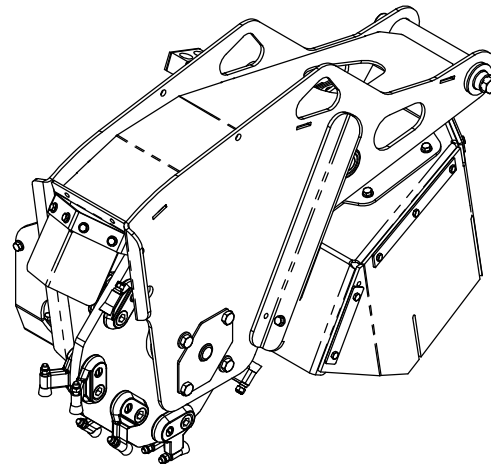

Go to Discount-Equipment.com to order your parts

BARRETO

TITLE: CUTTER HEAD ASSEMBLY
SG - CENTER PIVOT
PRODUCT LINE: 30SG - CP DATE: 10-13
SCALE: 1:12 DWG# 00536
SHEET 2 OF 2

ITEM NO.	QTY.	PART NO.	DESCRIPTION
1	1	12713	CYLINDER ROD
2	1	03255	WIPER, 1 X 1-1/2 X 5/16 J-1000
3	1	03259	SEAL, 1x1/8x1/8 ROD
4	1	12708	SWING CYLINDER, CP
5	1	05046	NUT, GRIPCO, 1/2-13 NC G5 ZINC
6	1	05102	WASHER, 1/2 SAE ZINC HARDENED
7	1	10492	O-RING, 2-224, 2 OD X 1/8 SECTION
8	2	10493	BACK-UP RING, 8-224N90 PARBAK
9	1	12255	PISTON, 2"
10	1	03232	O-RING, 2-014, 5/8 OD X 1/16 SECTION
11	1	10490	O-RING, 2-133, 2 OD X 3/32 SECTION
12	1	12257	END CAP
13	1	05024	SNAP RING, HO-206, 2.06" INTERNAL
14	1	12792	JAM SPACER
15	1	12791	SPHERIC ROD EYE, 3/4-16 MALE

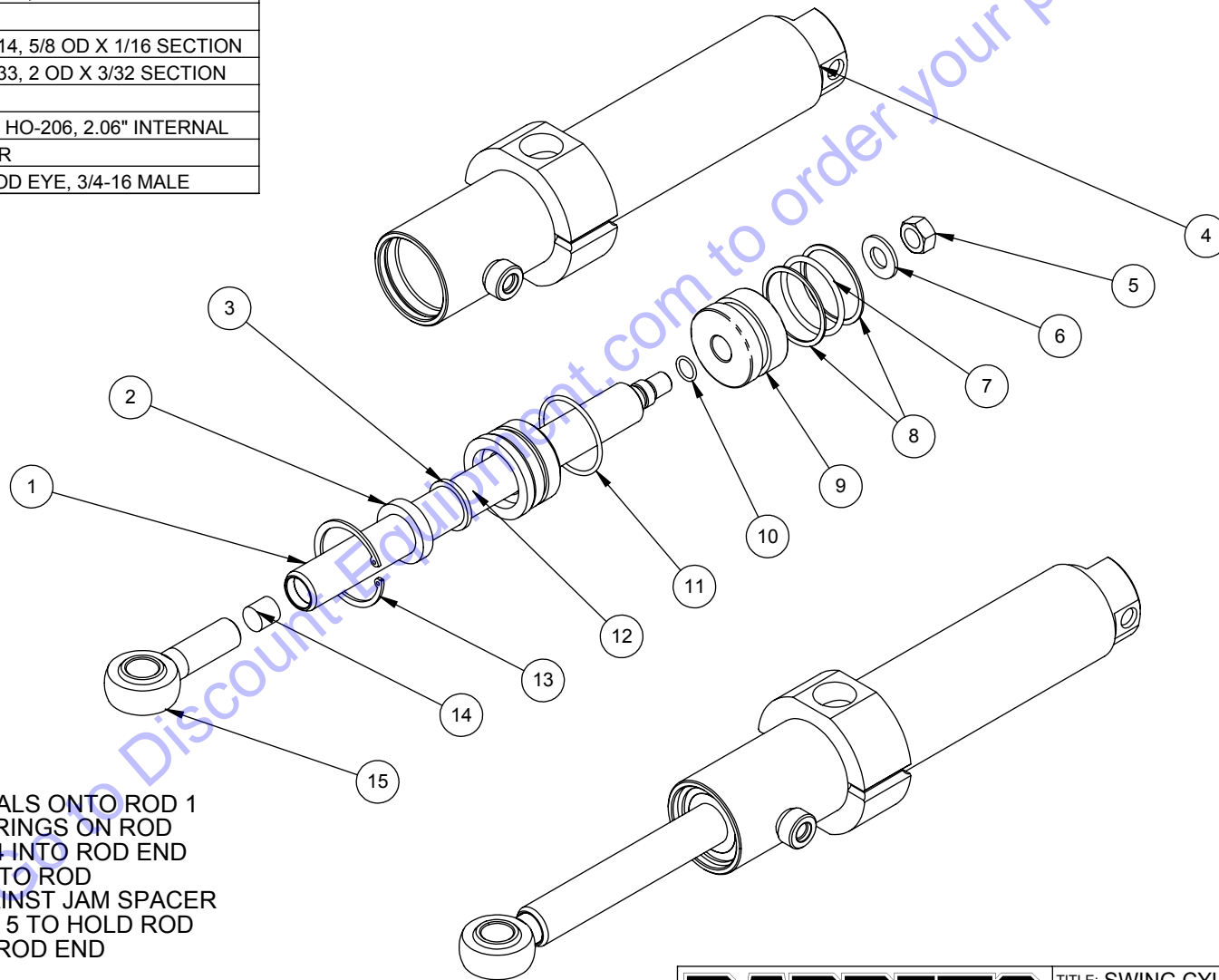

TO ASSEMBLE ROD 1:
 SLIDE CAP 12 WITH SEALS ONTO ROD 1
 INSTALL PISTON 9 & O-RINGS ON ROD
 INSERT JAM SPACER 14 INTO ROD END
 SCREW ROD EYE 15 INTO ROD
 TIGHTEN ROD EYE AGAINST JAM SPACER
 USE A SOCKET ON NUT 5 TO HOLD ROD
 USE RED LOCTITE ON ROD END
 60 - 70 FT-LB

BARRETO

TITLE: SWING CYLINDER ASSEMBLY
 CENTER PIVOT SG
 PRODUCT LINE: 30SG - CP DATE: /08
 SCALE: 1:4
 SHEET 1 OF 1 DWG# 00538

ITEM NO.	QTY.	PART NO.	DESCRIPTION
1	1	12785 R1	SHIELD FRAME
2	1	12788 R1	SHIELD MOUNT
3	1	12859	SHIELD BRACKET
4	1	12797	FLAP KEEPER
5	1	12786	SHIELD
6	1	12796	SHIELD FLAP
7	1	03351	LANYARD 5.5" LONG & HAIR SPRING COTTER
8	2	05059	HH CAP SCREW, 3/8-16 NC X 1 G5 ZINC
9	4	05101	WASHER, 3/8 SAE ZINC
10	2	05073	NUT, NYLOCK, 3/8-16 NC ZINC
11	2	05356	SH SHOULDER SCREW, 3/8 X 5/8
12	2	05273	NUT, NYLOCK, 5/16-18 NC ZINC
13	4	05403	HHFS 1/4-20 X 1-1/4, G5, ZN
14	2	05368	WHIZ-LOCK 1/4 - 20 X 1
15	6	05049	WHIZ-LOCK 1/4 - 20 X 3/4
16	1	05069	WHIZ LOCK, 1/4-20 NC X 5/8 ZINC
17	12	05545	WASHER, 1/4 X 1 1/4 ZN
18	13	05096	NUT, NYLOCK, 1/4-20 NC ZINC

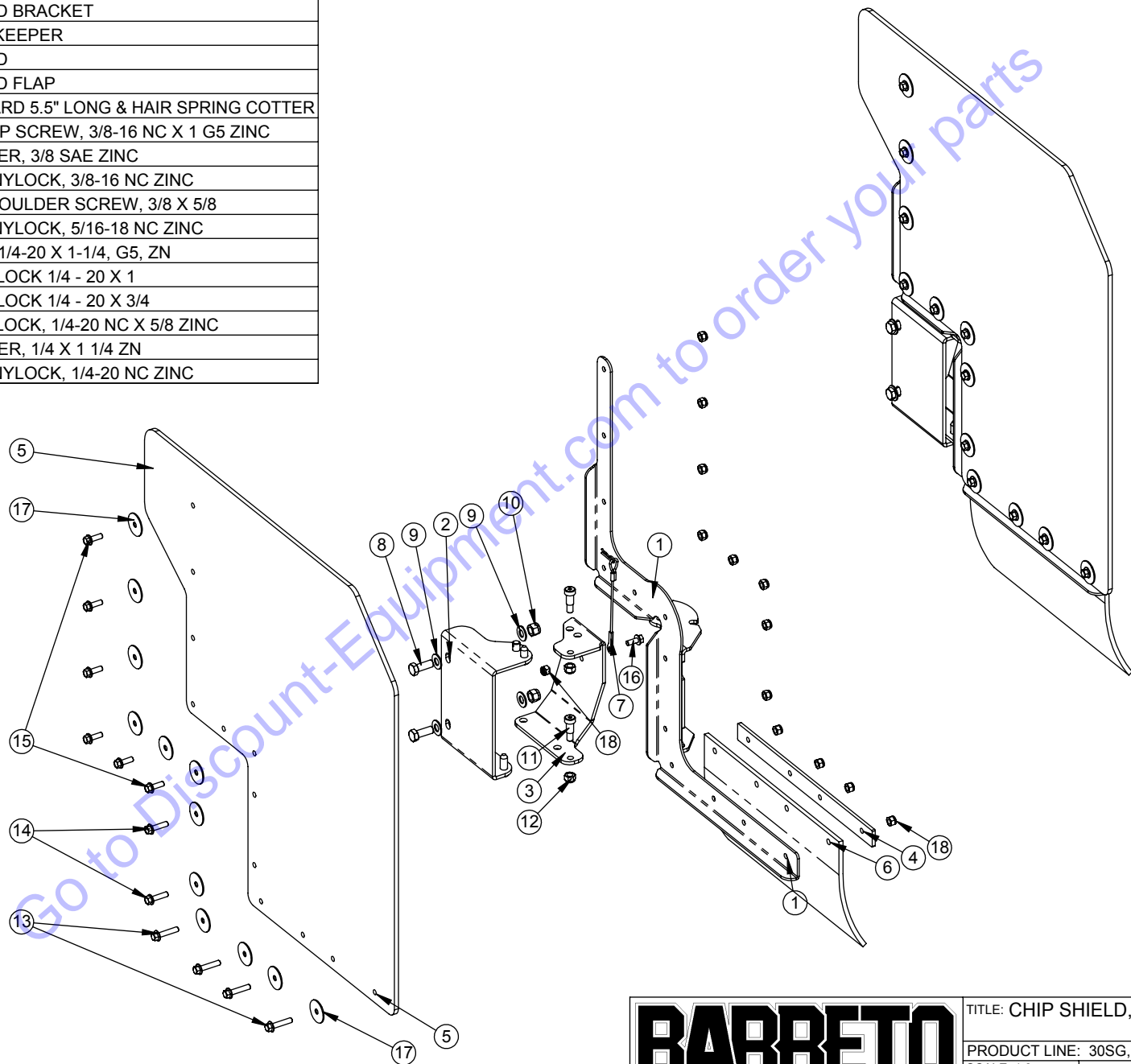

ITEM NO.	QTY.	PART NO.	DESCRIPTION
1	1	13300	BEARING MOUNT
2	1	13301-SG	MOUNT END PLATE
3	1	13390	STUB SHAFT, B31
4	1	13312	1-1/4 -20 NUT
5	1	13313 R1	9-TOOTH INSERT
6	1	13315	BEARING SPACER
7	1	13310	40x52x7 SEAL
8	2	10618	BALL BEARING, 6207 2Z
9	1	04555	FITTING, 6801-4-4
10	2	03001	O-RING, 2-152, 3-7/16 OD X 3/32 SECTION
11	1	03300	FITTING, 6409-4 PLUG
12	1	03300-M	PLUG, 6409-4, MAGNETIC
13	3	12380	HH CAP SCREW, M8-1.25 X 25MM ZINC
14	4	05567	HHFS 5/16-18 X 1, G5, ZN
15	1	13483	VENT HOSE ASSEMBLY- SG30

FILL WITH 1.5 OZ OF ANY AUTOMATIC TRANSMISSION FLUID (ATF)

RELEASE DATE	6/16/2016
REVISED DATE	01/04/2019
REVISION #	3

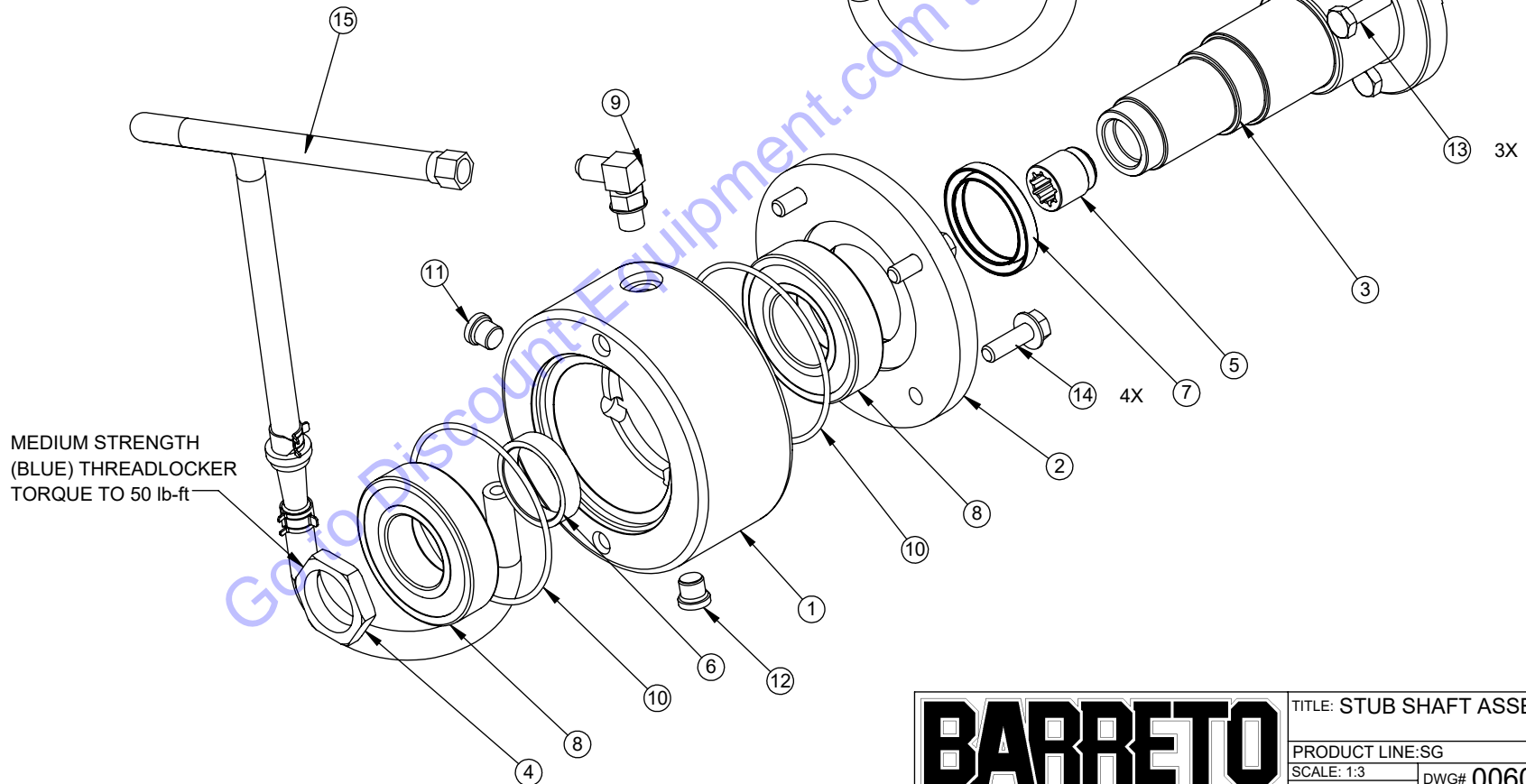

BARRETO

TITLE: STUB SHAFT ASSEMBLY, BRIGGS

PRODUCT LINE:SG

SCALE: 1:3

SHEET 1 OF 1

DWG# 00605-B-SG

REF	QTY.	PART NO.	DESCRIPTION
1	4	10757	HH CAP SCREW, 3/8-16 NC X 4 G5 ZINC
2	4	05101	WASHER, 3/8 SAE ZINC
3	4	11634	WEIGHT, 3/4 X 10
4	1	11539	BATTERY MOUNT
5	1	11321	BATTERY CABLE, POS
6	1	11322	BATTERY CABLE, NEG
7	1	11537	BATTERY, GT-X U1 300
8	1	11542	BATTERY CAP, W/ PAD
9	2	05273	NUT, NYLOCK, 5/16-18 NC ZINC
10	4	10615	WASHER, 5/16 USS ZINC
11	2	11258	RUBBER BUMPER
12	2	05096	NUT, NYLOCK, 1/4-20 NC ZINC
13	2	05081	WASHER, 1/4 SAE ZINC
14	2	05049	WHIZ LOCK, 1/4-20 NC X 3/4 ZINC
15	4	05073	NUT, NYLOCK, 3/8-16 NC ZINC

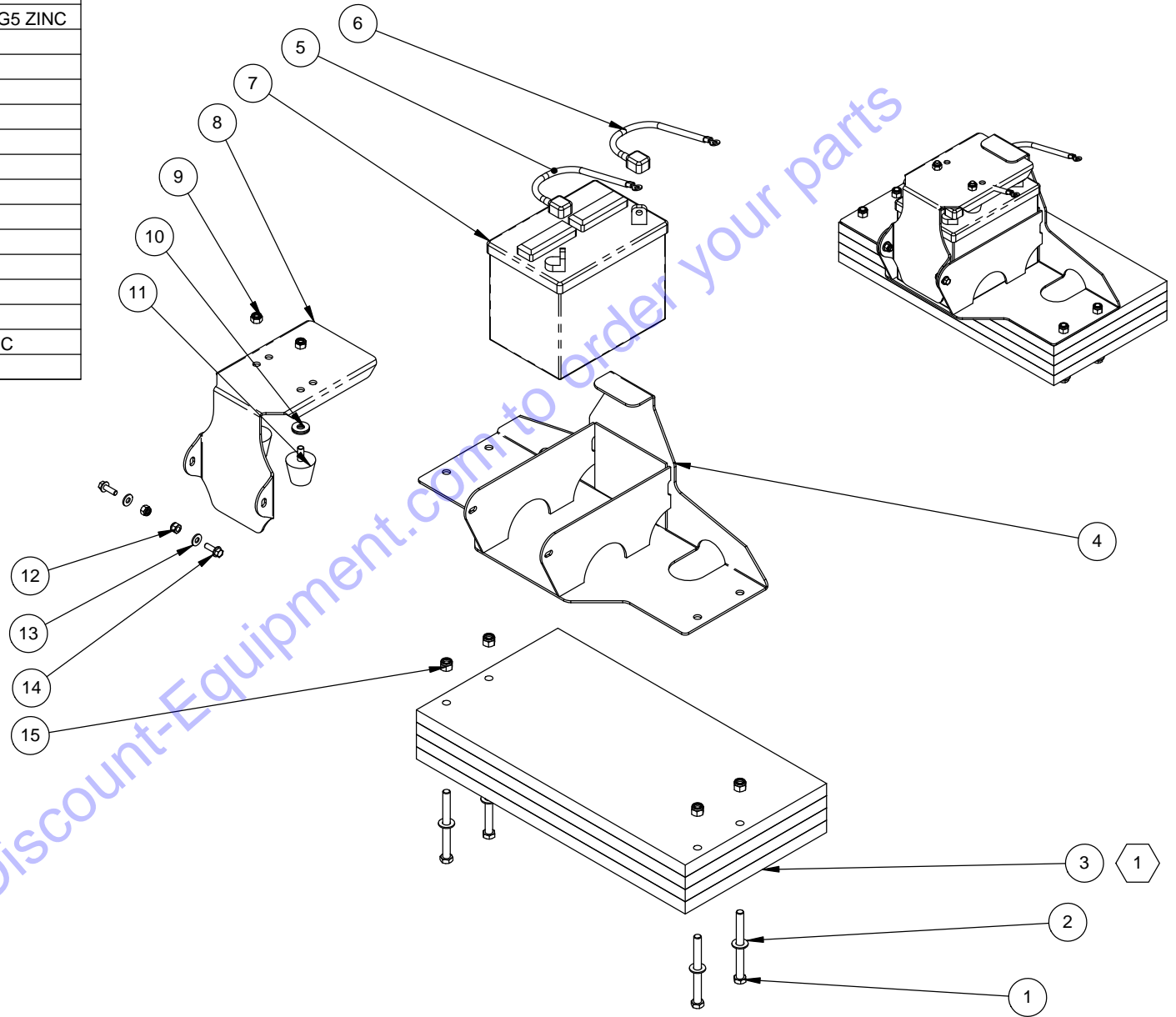

1 35 HP MODEL USES 3 WEIGHTS

BARRETO

TITLE: BATTERY & WEIGHT ASSEMBLY

PRODUCT LINE: 30SG / 35SG

DATE: 1/14

SCALE: 1:8

DWG# 00326-SG

SHEET 1 OF 1

ITEM NO.	QTY.	PART NO.	DESCRIPTION
1	1	12492	FUSE / RELAY HOLDER & WIRES
2	2	12493	RELAY
3	1	12494	FUSE, 5A
4	1	12495	FUSE, 15A
5	1	12492-1	COVER

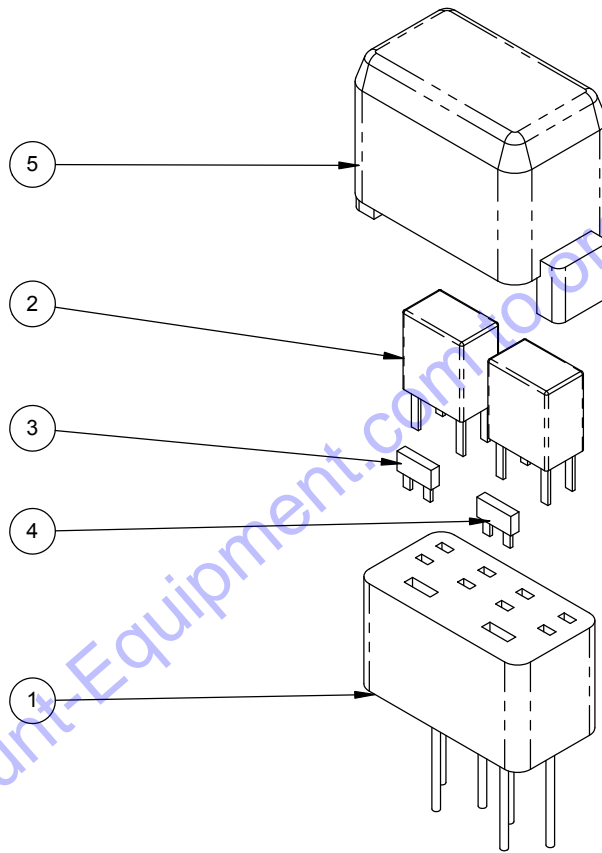

BARRETO

TITLE: FUSE / RELAY ASSEMBLY
 PRODUCT LINE: 30SG DATE: 7 / 13
 SCALE: 1:2 SHEET 1 OF 1 DWG# 12492-AS

ITEM NO.	QTY.	PART NO.	DESCRIPTION
1	1	13220 R1	LIFT EYE, SG
2	1	13221-L	FRONT MOUNT, LH
3	1	13221-R	FRONT MOUNT, RH
4	12	05091	HH CAP SCREW, 3/8-16 NC X 1-1/4 G5 ZINC
5	10	05101	WASHER, 3/8 SAE ZINC
6	8	05073	NUT, NYLOCK, 3/8-16 NC ZINC



7-5-2016

13220 R1 SHOWN - REVISED TO FIT BEARING MOUNTED PUMPS
 13220 R1 WILL FIT EARLIER UNITS

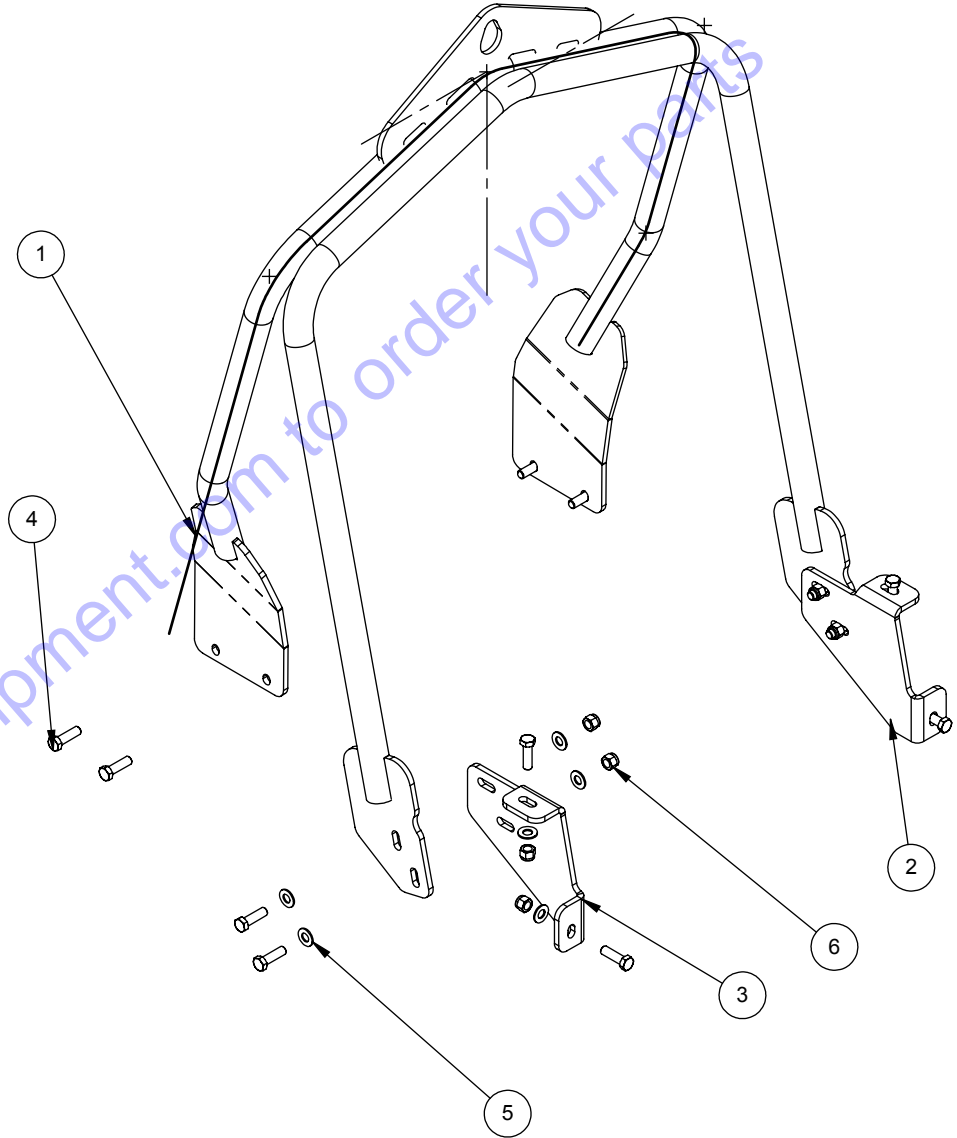
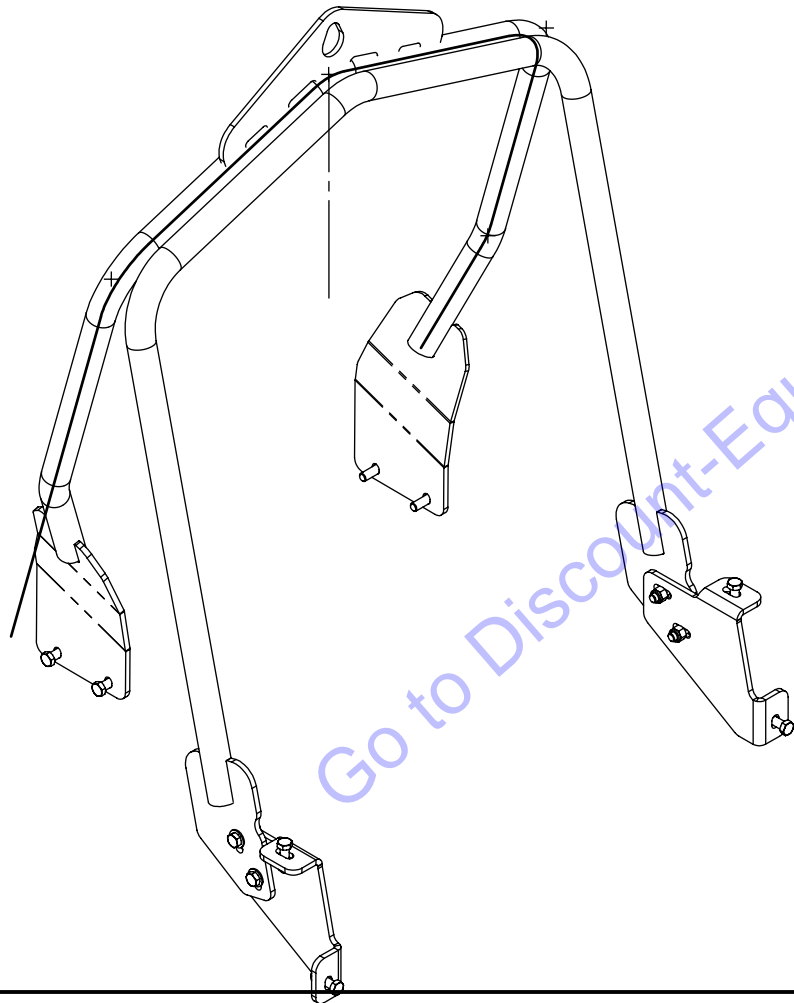

BARRETO

TITLE: LIFT EYE, SG RETRO-BOLT-ON

PRODUCT LINE: 30SG - OPTION DATE: 15-15

SCALE: 1:8

DWG# 13220-ASSEM

SHEET 1 OF 1

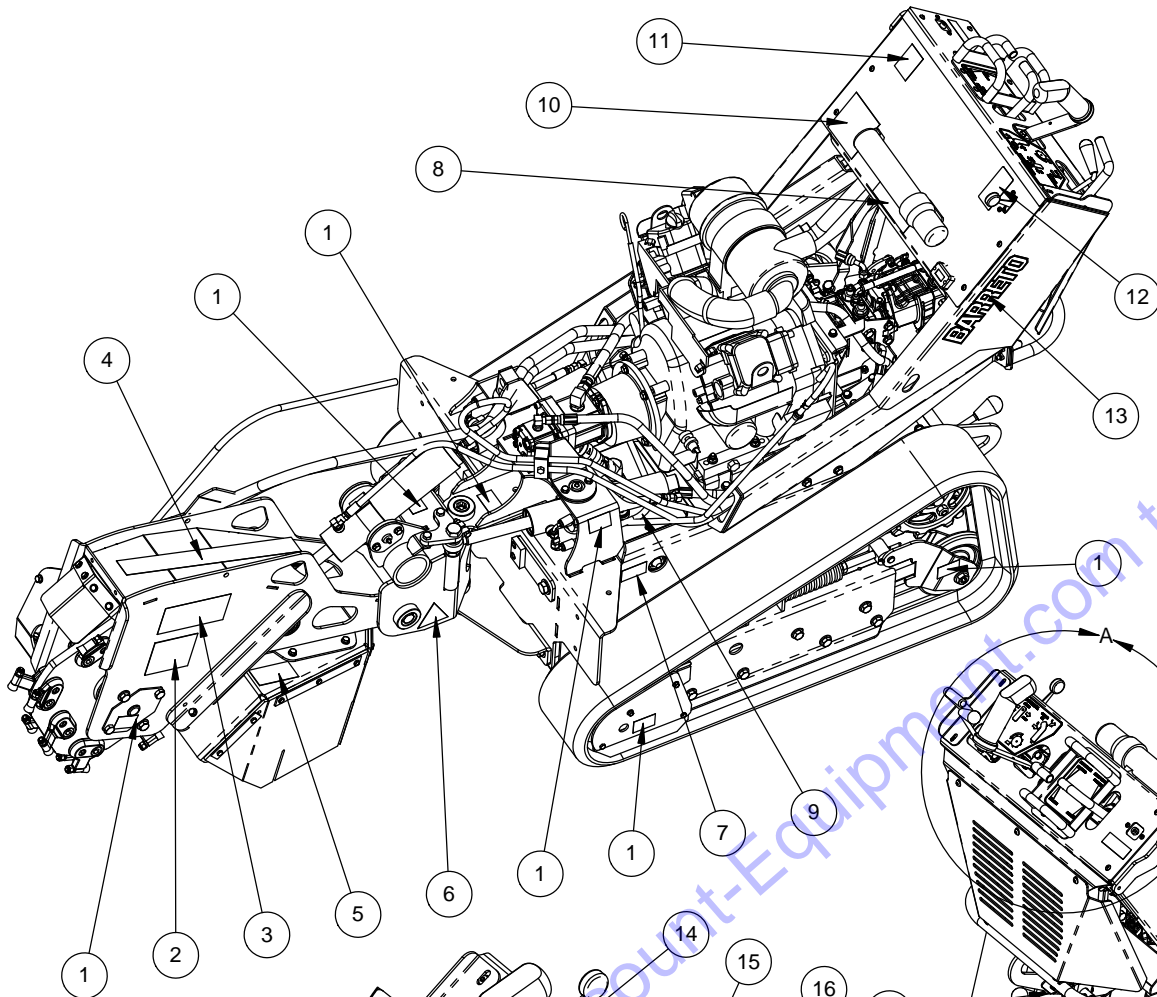

REF.	PART NO.	DESCRIPTION
1	03040-04	GREASE DAILY
2	04451-CP-05	GREASE CHART, SG
3	04451-04	30 SG
4	03341-02	DANGER STRIPES
5	04451-10	DANGER, ROTATING BLADE
6	04451-11	DANGER, PINCH POINT
7	03040-57	OIL LEVEL
8	04451-09	WARNING, READ MANUAL
9	03040-06	HYDRAULIC OIL ONLY
10	04451-06	SAFETY SYMBOLS, PROTECTIVE GEAR
11	03040-01	MADE IN USA
12	04440-05	THROTTLE
13	03040-02	BARRETO, (LARGE)
14	04451-CP-03	CUTTER CONTROL
15	04451-TK	TRACK CONTROL
16	03341-07	IGNITION, ON-OFF
17	04450-16	PARK BRAKE

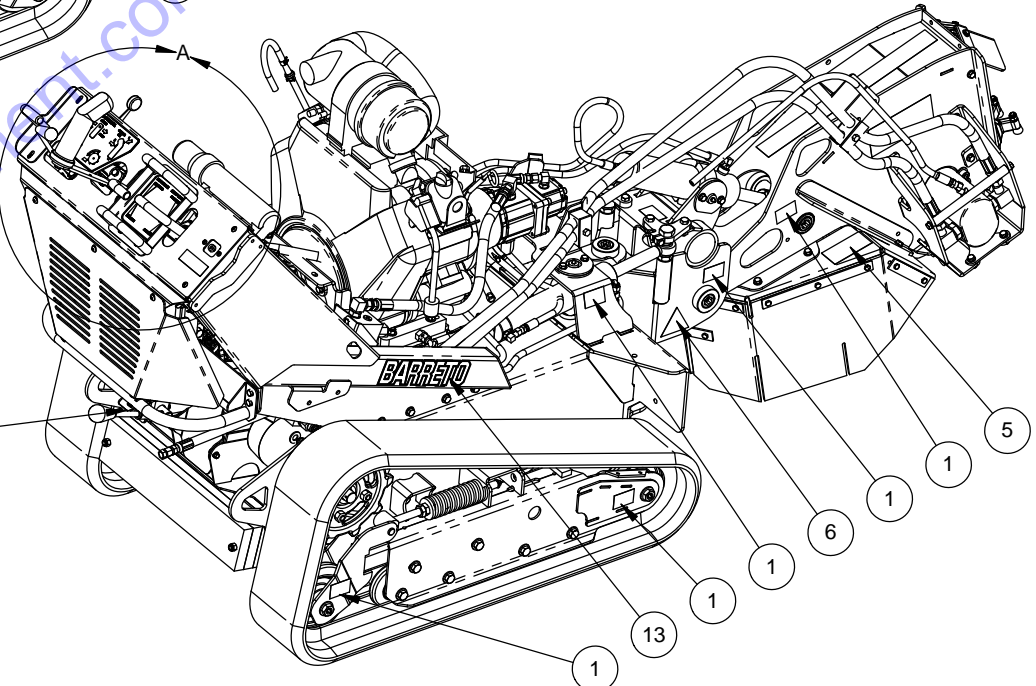

Copyright-Equipment.com to order your parts

DETAIL A
SCALE 1 : 8



TITLE: 30 SG DECAL LOCATION CHART
 PRODUCT LINE: 30 SG DATE: 1-22-16
 SCALE: 1:16 DWG# E30SG-DECALS
 SHEET 1 OF 1

CUTTER WHEEL REPLACEMENT PARTS

<u>Part#</u>	<u>Description</u>		
12280	Cutter tooth, includes collar and nut, 700 series Wearsharp		
12280-K	Set of 16 cutter teeth, Wearsharp		
12280-COMP	Complete set of teeth, holders and bolts for the cutter wheel		
12281	Tooth holder, straight. 700 Wearsharp		
12281-K	Tooth holder set of 16, includes 4 straight and 12 angled		
12282	Tooth holder, angled, 700 Wearsharp		
12283	Cutter bolt		
12283-K	Set of 16 cutter bolts		
12284	Tooth collar, 700 series Wearsharp		
05273	Tooth nut, 700 series Wearsharp		

Go to Discount-Equipment.com to order your parts

PARTS FINDER

**Search Website
by Part Number**



**Search Manual
Library For Parts
Manual & Lookup Part
Numbers – Purchase
or Request Quote**

Search Manuals

Enter your information to help us find the right parts manual for your machine.

* Brand:

* Model:

* Serial:

* Part Number:

SEARCH

**Can't Find Part or
Manual? Request Help
by Manufacturer,
Model & Description**

Parts Order Form

Please fill in the following information to help us find the right part for your machine.

Manufacturer:	<input type="text"/>
Model:	<input type="text"/>
Description:	<input type="text"/>
Part Number:	<input type="text"/>
Quantity:	<input type="text"/>
Notes:	<input type="text"/>

Discount-Equipment.com is your online resource for quality parts & equipment.

Florida: **561-964-4949** Outside Florida TOLL FREE: **877-690-3101**

Need parts?

Click on this link: <http://www.discount-equipment.com/category/5443-parts/> and choose one of the options to help get the right parts and equipment you are looking for. Please have the machine model and serial number available in order to help us get you the correct parts. If you don't find the part on the website or on one of the online manuals, please fill out the request form and one of our experienced staff members will get back to you with a quote for the right part that your machine needs.

We sell worldwide for the brands: Genie, Terex, JLG, MultiQuip, Mikasa, Essick, Whiteman, Mayco, Toro Stone, Diamond Products, Generac Magnum, Airman, Haulotte, Barreto, Power Blanket, Nifty Lift, Atlas Copco, Chicago Pneumatic, Allmand, Miller Curber, Skyjack, Lull, Skytrak, Tsurumi, Husquvarna Target, Stow, Wacker, Sakai, Mi-T-M, Sullair, Basic, Dynapac, MBW, Weber, Bartell, Bennar Newman, Haulotte, Ditch Runner, Menegotti, Morrison, Contec, Buddy, Crown, Edco, Wyco, Bomag, Laymor, EZ Trench, Bil-Jax, F.S. Curtis, Gehl Pavers, Heli, Honda, ICS/PowerGrit, IHI, Partner, Imer, Clipper, MMD, Koshin, Rice, CH&E, General Equipment, Amida, Coleman, NAC, Gradall, Square Shooter, Kent, Stanley, Tamco, Toku, Hatz, Kohler, Robin, Wisconsin, Northrock, Oztec, Toker TK, Rol-Air, APT, Wylie, Ingersoll Rand / Doosan, Innovatech, Con X, Ammann, Mecalac, Makinex, Smith Surface Prep, Small Line, Wanco, Yanmar