

# OPERATIONS MANUAL



## ***ESSICK SERIES***

### **MODEL EM-70S (STEEL) MODEL EM-70P (PLASTIC) PLASTER AND MORTAR MIXER (GASOLINE ENGINE/ELECTRIC MOTOR)**

Revision #1 (08/10/04)

**THIS MANUAL MUST ACCOMPANY  
THE EQUIPMENT AT ALL TIMES.**



[www.discount-equipment.com](http://www.discount-equipment.com)



# WARNING



## **CALIFORNIA — Proposition 65 Warning**

Engine exhaust and some of its constituents, and some dust created by power sanding, sawing, grinding, drilling and other construction activities contains chemicals known to the State of California to cause cancer, birth defects and other reproductive harm. Some examples of these chemicals are:

- Lead from lead-based paints.
- Crystalline silica from bricks.
- Cement and other masonry products.
- Arsenic and chromium from chemically treated lumber.

Your risk from these exposures varies, depending on how often you do this type of work. To reduce your exposure to these chemicals: **ALWAYS** work in a well ventilated area, and work with approved safety equipment, such as dust masks that are specially designed to filter out microscopic particles.



[www.discount-equipment.com](http://www.discount-equipment.com)

© COPYRIGHT 2004, Multiquip INC.

Multiquip Inc, the MQ logo and the Essick logo are registered trademarks of Multiquip Inc. and may not be used, reproduced, or altered without written permission. All other trademarks are the property of their respective owners and used with permission.

This manual **MUST** accompany the equipment at all times. This manual is considered a permanent part of the equipment and should remain with the unit if resold.

The information and specifications included in this publication were in effect at the time of approval for printing. Illustrations are based on the *MQ Essick EM-70 Series Plaster/Mortar Mixer*. Illustrations, descriptions, references and technical data contained in this manual are for guidance only and may not be considered as binding. Multiquip Inc. reserves the right to discontinue or change specifications, design or the information published in this publication at any time without notice and without incurring any obligations.

# EM-70 PLASTER/MORTAR MIXER — TABLE OF CONTENTS

## MQ ESSICK — EM-70 SERIES PLASTER/MORTAR MIXER

Here's How To Get Help .....	3
Table Of Contents .....	4
Parts Ordering Procedures .....	5
Specifications .....	6
Dimensions .....	7
Safety Messages Alert Symbols .....	8-9
Rules For Safe Operation .....	10-11
Towing Guidelines .....	12
Safety Chain Connection .....	13
Operation and Safety Decals .....	14
General Information .....	15
Major Components .....	16
Basic Engine Components .....	17
Electric Motor .....	18-19
Paddle Blade Adjustment (Steel Drum) .....	20
Paddle Blade Adjustment (Poly Drum) .....	21
Inspection .....	22-23
Start-Up Procedures .....	24-26
Operation .....	26
Shut-Down Procedures .....	27
Maintenance (Engine) .....	28-29
Maintenance (Mixer) .....	30-34
Troubleshooting (Engine) .....	35-36
Troubleshooting (Mixer/Electric Motor) .....	37
Electric Motor Wiring Diagram .....	38

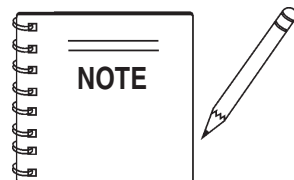

*Specifications and are  
subject to change without  
notice.*

# EM-70 PLASTER/MORTAR MIXER — SPECIFICATIONS

## TABLE 1. MIXER SPECIFICATIONS

Capacity	7.0 cu. ft (198 liters)
Bag Capacity	1-1/2 to 2-1/2 bags
Weight	788 lbs. (357 kg.)
Height W/Dump Handle	73 in. (185 cm.)
Discharge Height	21 in. (53 cm.)
Drive	V-Belt/Gear
Dump Action	Manual

## TABLE 2. SPECIFICATIONS (ENGINE & ELECTRIC MOTOR)

	Model	HONDA GX160K1HX2	HONDA GX240K1HA2	BALDOR 35L229S302
<b>Engine/Electric Motor</b>	Type	Air-cooled 4 stroke, Horizontal Shaft Gasoline Engine		1.5 HP, 115/230, Single Phase Electric Motor
	Bore X Stroke	2.51 in. X 1.65 in. (63.8 mm x 42 mm)	2.90 in. X 2.30 in. (73 mm x 58 mm)	N/A
	Displacement	8.75 cc	14.81 cc	N/A
	Max Output	5.5 HP/3600 R.P.M	8.0 H.P./3600 R.P.M.	1.5 H.P./1725 RPM
	Fuel Tank Capacity	.951 Gallons (3.6 Liters)	Approx. 1.59 U.S. Gallons (6 Liters)	N/A
	Fuel	Unleaded Gasoline		N/A
	Lube Oil Capacity	2-1/3 pints		N/A
	Speed Control Method	Centrifugal Fly-weight Type		N/A
	Starting Method	Recoil Start		N/A
	<b>Dimensions (L x W x H)</b>	12.2 x 14.2 X 13.8 in. (312 X 362 X 335 mm)	14.0 x 16.9 X 16.1 in. (355 X 430 X 410 mm)	13.3 x 8.7 X 9.06 in. (338 X 220 X 230 mm)
<b>Dry Net Weight</b>	33 lbs. (15 Kg.)	55.1 lbs. (25 Kg.)	Approx. 22 lbs. (10 Kg.)	



### NOTE



In accordance with our established policy of constant improvement, we reserve the right to amend these specifications at any time without notice.

# EM-70 PLASTER/MORTAR MIXER — DIMENSIONS

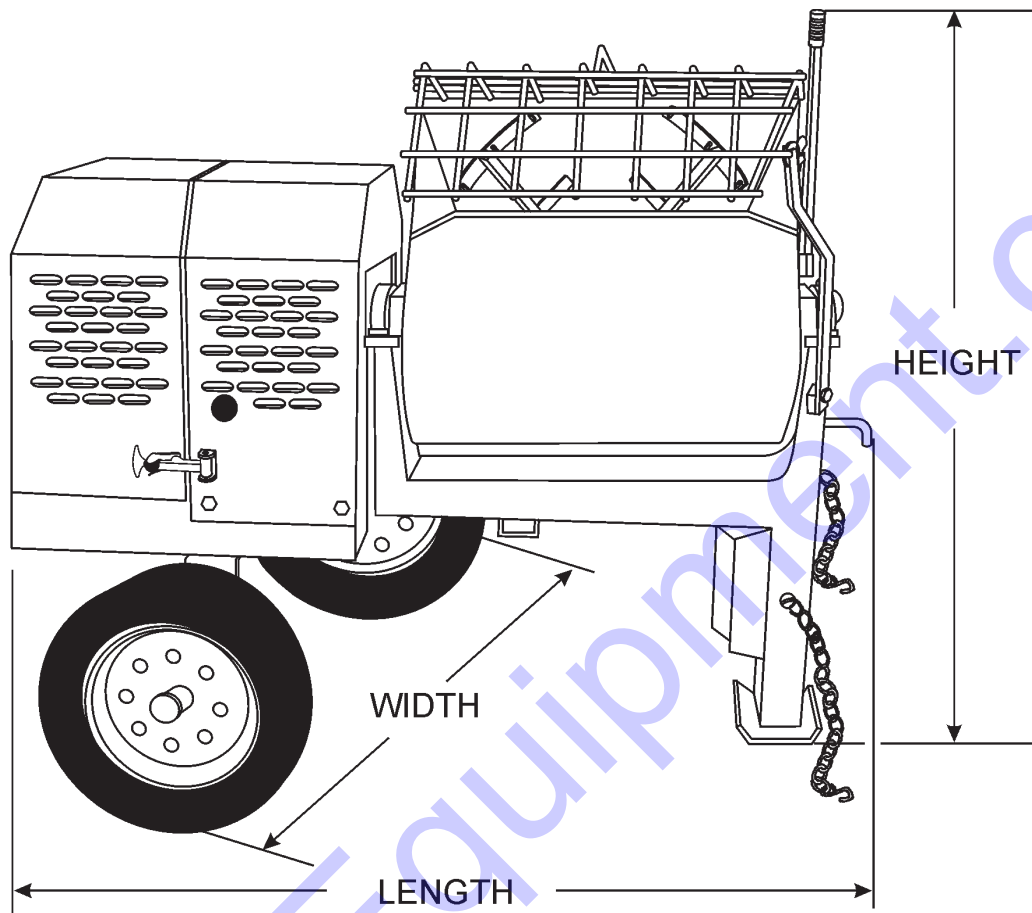

OPTIONAL TOW BARS  
APPROXIMATE LENGTH  
36 IN. (91.44 CM.)

HBC-1  
2-INCH  
BALL COUPLER

HPC-1  
1-INCH  
PIN COUPLER

HLC-1  
LOOP COUPLER

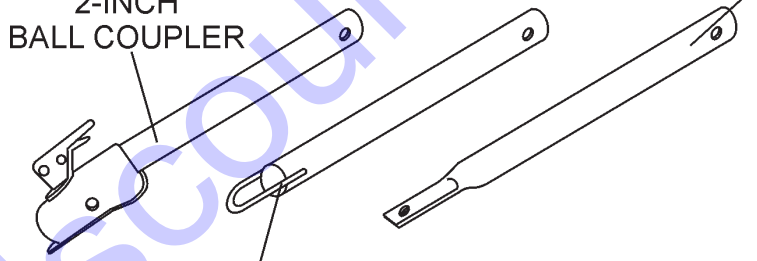

**TABLE 3. DIMENSIONS**

Description	Dimensions in. (cm)
Length (w/ Tow Bar)	67 in. (170 cm)
Width	50 in. (127 cm)
Height	56 in. (142 cm)

Figure 1. Dimensions

# EM-70 PLASTER/MORTAR MIXER — SAFETY MESSAGE ALERT SYMBOLS

## FOR YOUR SAFETY AND THE SAFETY OF OTHERS!

Safety precautions should be followed at all times when operating this equipment. Failure to read and understand the Safety Messages and Operating Instructions could result in injury to yourself and others.

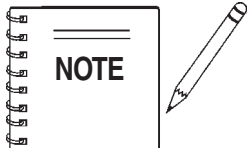

This Owner's Manual has been developed to provide complete instructions for the safe and efficient operation of the **MQ Essick EM-70 mortar and plaster** mixer. Refer to the engine manufacturers

instructions for data relative to its safe operation.

**Before using this mixer, ensure that the operating individual has read and understands all instructions in this manual.**

## SAFETY MESSAGE ALERT SYMBOLS

The three (3) Safety Messages shown below will inform you about potential hazards that could injure you or others. The Safety Messages specifically address the level of exposure to the operator, and are preceded by one of three words: **DANGER**, **WARNING**, or **CAUTION**.

### **DANGER**

You **WILL** be **KILLED** or **SERIOUSLY** injured if you **DO NOT** follow directions.

### **WARNING**

You **CAN** be **KILLED** or **SERIOUSLY** injured if you **DO NOT** follow directions.

### **CAUTION**

You **CAN** be **INJURED** if you **DO NOT** follow directions.

## HAZARD SYMBOLS

Potential hazards associated with the operation of an **EM-70 Plaster/Mortar Mixer** will be referenced with Hazard Symbols which appear throughout this manual, and will be referenced in conjunction with Safety Message Alert Symbols.

### **WARNING** Lethan Exhaust Gas Hazards

Engine exhaust gases contain poisonous carbon monoxide. This gas is colorless and odorless, and can cause death if inhaled. **NEVER** operate this equipment in a confined area or enclosed structure that does not provide ample free flow air.



### **WARNING** Explosive Fuel Hazards

**Gasoline** is extremely flammable, and its vapors can cause an explosion if ignited. **DO NOT** start the engine near spilled fuel or combustible fluids.



**DO NOT** fill the fuel tank while the engine is running or hot. **DO NOT** overfill tank, since spilled fuel could ignite if it comes into contact with hot engine parts or sparks from the ignition system. Store fuel in approved containers, in well-ventilated areas and away from sparks and flames.

### **WARNING** Burn Hazards

Engine components can generate extreme heat. To prevent burns, **DO NOT** touch these areas while the engine is running or immediately after operations. Never operate the engine with heat shields or heat guards removed.



### **WARNING** Respiratory Hazards

**ALWAYS** wear approved **respiratory** protection when required.



# EM-70 PLASTER/MORTAR MIXER — SAFETY MESSAGE ALERT SYMBOLS

## CAUTION

### Rotating Parts Hazards

**NEVER** operate equipment with covers, or guards removed. Keep fingers, hands, hair and clothing away from all moving parts to prevent injury.



## CAUTION

### Equipment Damage Hazards

Other important messages are provided throughout this manual to help prevent damage to your light tower, other property, or the surrounding environment.

## CAUTION

### Accidental Starting Hazards

**ALWAYS** place the power source, circuit breakers or **ON/OFF** switch in the **OFF** position, when the generator is not in use, unless connected to transfer switch.



## CAUTION

### Eye and Hearing Hazards

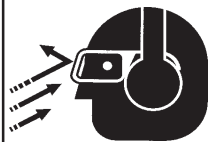

**ALWAYS** wear approved eye and hearing protection.



# EM-70 PLASTER/MORTAR MIXER — RULES FOR SAFE OPERATION

## DANGER

Read this manual!

Failure to follow instructions in this manual may lead to serious injury or even death! This equipment is to be operated by trained and qualified personnel only! This equipment is for industrial use only.

The following safety guidelines should always be used when operating the EM-70 plaster and mortar mixer:

### GENERAL SAFETY

■ **DO NOT** operate or service this equipment before reading this entire manual.



■ This equipment should not be operated by persons under 18 years of age.

■ **NEVER** operate this equipment without proper protective clothing, shatterproof glasses, steel-toed boots and other protective devices required by the job.



■ **NEVER** operate this equipment when not feeling well due to fatigue, illness or taking medicine.

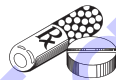

■ **NEVER** operate this equipment under the influence of **drugs** or **alcohol**.



■ **ALWAYS** wear proper respiratory (mask), hearing and eye protection equipment when operating the mixer.



■ **NEVER** place hands inside the drum while the blades are rotating.

■ Whenever necessary, replace nameplate, operation and safety decals when they become difficult read.

■ Manufacture does not assume responsibility for any accident due to equipment modifications.

■ **NEVER** use accessories or attachments, which are not recommended by Multiquip for this equipment. Damage to the equipment and/or injury to user may result.

■ **NEVER** touch the hot exhaust manifold, muffler or cylinder. Allow these parts to cool before servicing engine or mixer.

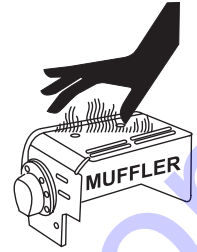

■ **High Temperatures** – Allow the engine to cool before adding fuel or performing service and maintenance functions. Contact with **hot!** components can cause serious burns.

■ The engine section of this mixer requires an adequate free flow of cooling air. **NEVER** operate the mixer in any enclosed or narrow area where free flow of the air is restricted. If the air flow is restricted it will cause serious damage to the mixer or engine and may cause injury to people. Remember the mixer's engine gives off **DEADLY** carbon monoxide gas.

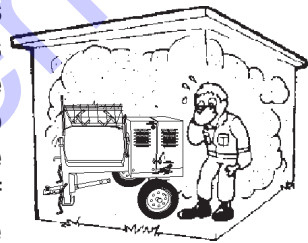

■ **ALWAYS** refuel in a well-ventilated area, away from sparks and open flames.

■ **ALWAYS** use extreme caution when working with **flammable** liquids. When refueling, **stop the engine** and allow it to cool. **DO NOT smoke** around or near the machine. Fire or explosion could result from fuel vapors, or if fuel is spilled on a hot engine.



■ **NEVER** operate the mixer in an explosive atmosphere or near combustible materials. An explosion or fire could result causing severe **bodily harm or even death**.

■ Topping-off to filler port is dangerous, as it tends to spill fuel.

■ Stop the engine when leaving the mixer unattended.

■ Block the unit when leaving or when using on a slope.

■ Maintain this equipment in a safe operating condition at all times.

## WARNING

### Starting the Mixer Engine

**NEVER!** start the engine or engage the paddle arms when the drum is in the discharge (down) position.

# EM-70 PLASTER/MORTAR MIXER — RULES FOR SAFE OPERATION

- **ALWAYS** stop the engine before servicing, adding fuel and oil.
- **NEVER** run engine without air filter. Severe engine may occur.
- **ALWAYS** service air cleaner frequently to prevent carburetor malfunction.
- **ALWAYS** be sure the operator is familiar with proper safety precautions and operations techniques before using mixer.
- **ALWAYS** store equipment properly when it is not being used. Equipment should be stored in a clean, dry location out of the reach of children.
- **DO NOT** operate this equipment unless all guards and safety devices are attached and in place.
- **CAUTION** must be exercised while servicing this equipment. Rotating and moving parts can cause injury if contacted.
- When towing, an adequate safety chain must be fastened to the frame. See Towing Guidelines section in this manual.
- Keep all ***inexperienced*** and ***unauthorized*** people away from the equipment at all times.
- Unauthorized equipment modifications will void all warranties.
- Check all fasteners periodically for tightness. Also check towing tongue bolt, lock nut and wheel lug nuts for wear.
- Stop the engine and disconnect the spark plug before allowing anybody's hands in the mixing drum.
- **NEVER** pour or spray water over the engine or electric motor.

## **WARNING**

### **Stand Clear of the Mixer when in use**

Always stand clear of the dump handle when the mixer is in operation. Any binding of material between the mixer blades and the drum will cause the drum handle to quickly move and could cause bodily harm.

- Depending on type of mixer, test the **ON/OFF** switch for either the gasoline engine or electric motor before operating. The purpose of these switches is to shut down the engine or motor of the mixer.
- Refer to the **HONDA Engine Owner's Manual** for engine technical questions or information recommended by Multiquip for this equipment. Damage to the equipment and/or injury to user may result.

## TRANSPORTING

- **ALWAYS** shutdown engine before transporting.
- Tighten fuel tank cap securely and close fuel cock to prevent fuel from spilling.
- Drain fuel when transporting mixer over long distances or bad roads.

## MAINTENANCE

- **NEVER** lubricate components or attempt service on a running mixer.
- **ALWAYS** allow the mixer a proper amount of time to cool before servicing.
- Keep the mixer in proper running condition.
- Fix damage to the mixer immediately and always replace broken parts.
- Dispose of hazardous waste properly. Examples of potentially hazardous waste are used motor oil, fuel and fuel filters.
- **DO NOT** use food or plastic containers to dispose of hazardous waste.

## EMERGENCIES

- **ALWAYS** know the location of the nearest **fire extinguisher** and **first aid kit**.



- In emergencies **always** know the location of the nearest phone or **keep a phone on the job site**. Also know the phone numbers of the nearest **ambulance**, **doctor** and **fire department**. This information will be invaluable in the case of an emergency.



# EM-70 PLASTER/MORTAR MIXER — TOWING GUIDELINES

## Towing Safety Precautions



### CAUTION

#### Regularly Inspect Towing Components

To reduce the possibility of an accident while transporting the mixer on public roads, always make sure that the mixer towing components and the towing vehicle are in good operating condition and both units are mechanically sound.

The following list of suggestions should be used when towing the mixer:

- Check with your county or state safety towing regulations department before towing your **mixer**.
- Make sure that the hitch and coupling of the towing vehicle are rated equal to, or greater than the trailer "gross vehicle weight rating" (GVWR).
- **ALWAYS** inspect the hitch and coupling for wear. **NEVER** tow the mixer with defective hitches, couplings, chains etc.
- **CHECK** the tire air pressure on both the towing vehicle and the trailer. Also check the tire tread wear on both vehicles.
- **ALWAYS** make sure the mixer is equipped with a "Safety Chain".
- **ALWAYS** attach trailer's safety chain to the frame of towing vehicle.
- **ALWAYS** make sure that the towing vehicle's directional, backup, and brake lights are working properly.
- Remember in most cases the maximum speed unless otherwise posted for highway towing is **55 MPH**, however before towing your mixer, check your local state, and county vehicle towing requirements. Recommended off-road towing is not to exceed **10** or **15 MPH** or less depending on type of terrain.
- Place *chocked blocks* underneath wheels to prevent **rolling**, while parked, if disconnected from towing vehicle.
- Inflate tires to correct pressure, inspect tires for cuts, and excessive wear. See Table 4 (Tire Wear Troubleshooting).
- When towing of the mixer is required, place the drum in the up position (mouth facing upwards) and lock the drum latch.

- **ALWAYS** make sure that the fuel valve lever is in the **OFF** position (gasoline models only).
- Check wheel mounting lug nuts with a **torque wrench**. Torque wheel lug nuts as described in the maintenance section of this manual.
- Check tightness of U-clamp nuts, torque suspension hardware as referenced in the maintenance section of this manual.
- Avoid sudden stops and starts. This can cause skidding, or jackknifing. Smooth, gradual starts and stops will improve gas mileage.
- Avoid sharp turns to prevent rolling.

## Tow Bar to Vehicle Connection (Coupler Only)

1. Check the vehicle hitch ball, and mixer's coupler for signs of wear or damage. Replace any parts that are worn or damaged before towing.



### CAUTION

#### Replacing Towing Components

If the mixer tow bar is deformed or damaged, replace the **entire** tow bar. **NEVER** tow the mixer with a defective tow bar. There exists the possibility of the mixer separating from the towing vehicle.

2. Use only a 2-inch ball diameter (towing vehicle), this will match the mixer's 2-inch coupler. Use of any other ball diameter will create an extremely dangerous condition which can result in separation of the coupler and ball or ball failure.
3. After tow bar has been connected to mixer (see next page), attach mixer's coupler to the hitch ball on the towing vehicle securely and make sure the lock lever is in the down position (locked).

## Mixer Tow Bar Vehicle Connection (Pentle and Loop)

1. Make sure the bumper on the towing vehicle is equipped to handle either a pentle or loop type tow bar configuration.
2. After tow bar has been connected to mixer (see next page), secure either type of tow bar to the towing vehicle, following state and county towing regulations.
3. As a minimum, use a 1/2-inch bolt and nylock nut grade 5 when securing the tow bar to the towing vehicle and to the unit being towed.

# EM-70 PLASTER/MORTAR MIXER — SAFETY CHAIN CONNECTION

## CAUTION

### Always Tow with a Safety Chain

**NEVER!** tow the mixer with the safety chain removed. The safety chain is intended to prevent complete separation of the mixer from the towing vehicle in the event of a tow bar failure.

Reference Figure 2 for the installation of the **safety chain**.

### Tow Bar to Mixer Connection

1. Insert the tow bar through the round opening at the bottom of the mixer stand.

Align the hole on the tow bar with the hole on the mixer frame, and insert 1/2-inch bolt through tow bar and frame. Secure tow bar to frame with 1/2-inch nylock nut. Tighten to 40 ft.-lbs.

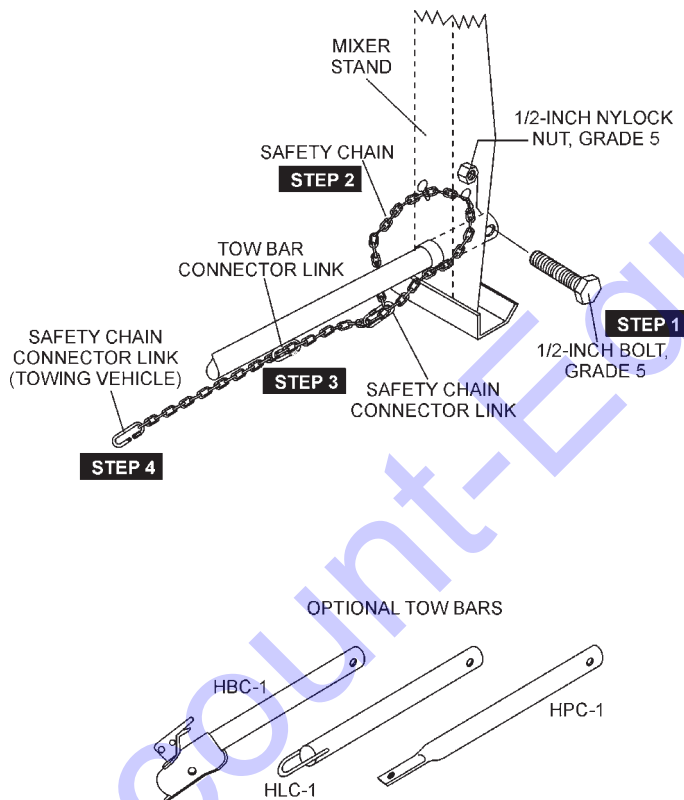

Figure 2. Tow Bar and Safety Chain Installation

2. Route the safety chain through the holes just above the tow bar, located on each side of the mixer stand. Loop the chain together and place under the tow bar. Secure the loop with the connector link.
3. extend the safety chain along the length of the tow bar, looping it through the tow bar's connector link. Remove any excess chain slack.
4. Connect the free end of (connector link) the safety chain to the towing vehicle. Remember it is critical that the length of the chain be properly adjusted, to prevent the **draw bar** and the front of the mixer stand from dropping to the the ground (contact) in the event the draw bar becomes disconnected from the towing vehicle.

## CAUTION

### Drum Safety when Towing

**DO NOT** tow the mixer unless the mixing drum is **completely empty**. **ALWAYS** make sure the drum latch pin is fully engaged to the *right* (Figure 3) of the drum stop block. This will keep the drum from rotating.

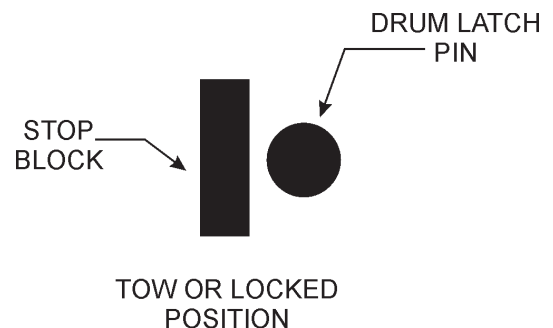
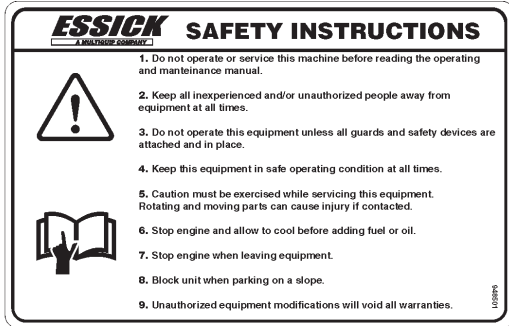

Figure 3. Drum Latch Pin (Tow or Locked Position)

# EM-70 PLASTER/MORTAR MIXER — OPERATION AND SAFETY DECALS

## Machine Safety Decals

The MQ Essick EM-70 mortar and plaster mixer is equipped with a number of safety decals. These decals are provided for operator safety and maintenance information. Figure 4 below illustrates these decals as they appear on the machine. Should any of these decals become unreadable, replacements can be obtained from your dealer.



P/N 948501



P/N 948121



CONTACT MQ PARTS DEPARTMENT



P/N: 13118



P/N: DCL280A



P/N: DCL335

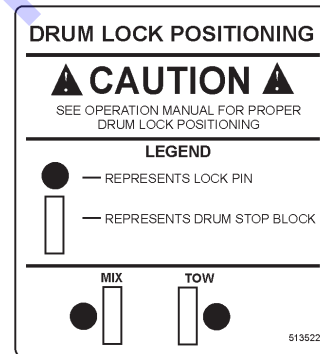

P/N 513522

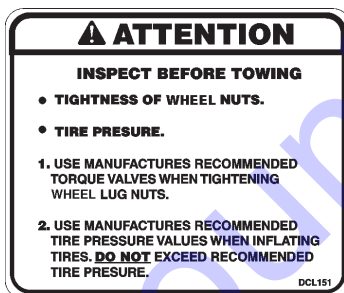

P/N DCL151



P/N 513479



P/N: DCL160A



P/N EM510883



P/N: EM948630



P/N EM510891



P/N: 35137

Figure 4. Mixer Operation and Safety Decals



# EM-70 PLASTER/MORTAR MIXER — GENERAL INFORMATION

## Application

The MQ Essick EM-70 series mixers (drum capacity of 7.0 cu. ft./198 liters) are shipped completely assembled and have been factory tested and are ready for use.

This mixer is **only** intended for the production of **plaster** and **mortar**. The mixer must be used for its intended purpose and is not suitable for the mixing of **flammable** or **explosive** substances. The mixer **must not be used** in an explosive atmosphere. This mixer has a batch capacity between 2-1/2 and 3-1/2 bags.

## Power Plants

The EM-70 can be powered by either a Honda GX240K1HA2 or GX160K1HX2 air-cooled, 4-stroke gasoline engine or a 1.5 electric motor. Refer to Table 2 for specific engine or electric motor data information.

## Electrical

If mixer is equipped with an **electric motor**, make sure that the power being supplied to the motor corresponds to the voltage rating label on the motor. Supplying the wrong voltage to the electric motor will cause severe electrical damage to the motor.

Always make sure the **OFF/ON** switch on the electric motor is in the **OFF** position before applying power.

It is **strongly recommended** when inserting the mixer's power cord into a receptacle, that a G.F.C.I. (**Ground Fault Current Interrupter**) receptacle be used (115 VAC applications).

## Extension Cables

The extension cable should be a 3-wire configuration that includes a ground wire that conforms to UL code. The wire cross section must be a minimum of 2.5 mm<sup>2</sup>. Choose an extension cord of adequate current carrying capacity as referenced in Table 5. Remember **cable distance** affects the current-voltage capacity of the extension cable.

Ensure that the extension cable is carefully laid out avoiding **wet areas**, **sharp edges** and locations where vehicles might run over it. Avoid allowing the extension cable to be trapped underneath the mixer.

Unroll the extension cable fully or it will overheat and could catch fire. Make sure that all extension cable connections are dry and safe. Replace any defective or badly worn extension cable immediately.

## Hardware

Check all hardware on the mixer before starting. Periodically inspect all hardware. Loose hardware can contribute to early component failure and poor performance. Use Table 4 as general guideline when torqueing of mixer hardware is required. Remember to keep all mixer hardware components tight.

Table 4. Hardware Torque Recommendations

Hardware Diameter	Torque (ft-lbs)
5/16-inch x 18	14
3/8-inch x 16	24
3/8-inch x 24	37
1/2-inch x 13	39
1/2-inch x 13 (Grade 8)	90

## Engine Maintenance

For basic engine maintenance, refer to the engine maintenance section in this manual. For a more detailed engine maintenance, refer to the **Honda** Engine Owner's manual furnished with the engine.

## EM-70 PLASTER/MORTAR MIXER — MAJOR COMPONENTS

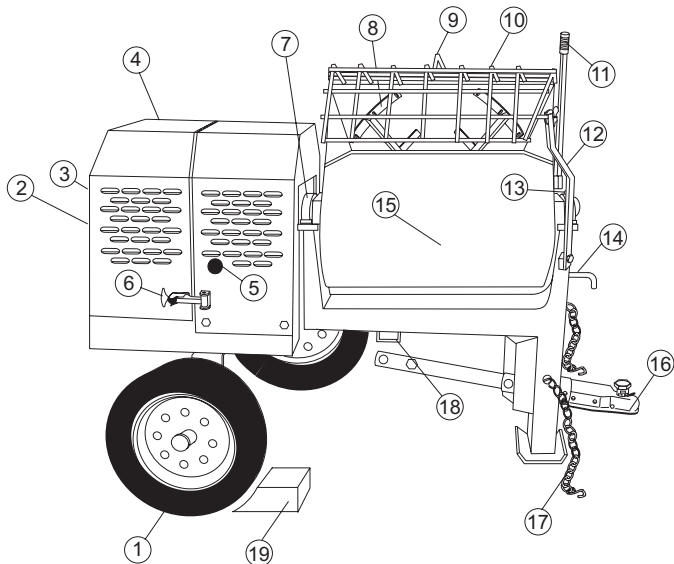

**Figure 5. Mixer Components**

Figure 5 illustrates the basic components and controls of the MQ Essick EM-70 mixer

1. **Tires Ply** -The tire ply (layers) number is rated in letters; This mixer uses 13-inch 4-ply tires.
2. **Engine Cover** -Lift this cover to gain access to the engine compartment.
3. **Belt Slip Lever** -When starting this lever should be move upward and to the left. For mixing place the lever in the down position. See attached decal located adjacent to lever.
4. **ON/OFF Switch (electric)** -This switch is provided on mixers with electric motors. To gain access to this switch, lift the engine cover. When activated it will shut down the electric motor.
5. **ON/OFF Switch (gasoline)** -This switch is provided on mixers with gasoline engines only and is located on the side of the engine cover. When activated it will shut down the engine.
6. **Latch** -Use this latch to secure the engine compartment cabinet.
7. **Drum Bearing** -There is on each end of the mixing drum, a sealed bearing. Bearings are packed and sealed at the factory and require no further maintenance.
8. **Mixing Paddles** -Used in the mixing of material. This unit uses four different types of paddles to provide a fast uniform mix.
9. **Bag Cutter**-This feature allows compound mixing bags to be opened easily, therefore allowing the contents of the bag to fall directly into the mixing drum.
10. **Safety Grill** -Provided for operator safety. This safety grill is designed to keep hands and solid objects out of the mixing drum when in use. This grill should be closed at all times when mixer is in use. **DO NOT** remove the grill or grill opening bar. Keep the grill clean by washing it down daily.
11. **Dump Handle** -Pull this handle downward to dump the contents of the drum. Push the handle upward to return the drum to its vertical position.
12. **Safety Grill Lock Handle** -To prevent injury to hands and arms, the safety grill should **ALWAYS** be locked when the mixing of plaster or mortar is required. Also when transporting the mixer the safety grill should be locked. The safety grill should only be un-locked when cleaning of the blades and drum is required.
13. **Pivot Point/Zerk Fitting** -There is, on each end of the mixing drum a zerk grease fitting. These fittings lubricate the dumping mechanism. Lubricate both fittings at least twice a week.
14. **Dump Handle Release Pin** -Pull this pin outward (spring loaded) to release the drum, then pull down on the dump handle to place the drum in the dump position. When drum is in dump position, pin will automatically lock drum.
15. **Mixing Drum** -Mixing materials such as mortar, plaster are to be placed into this drum for mixing. Always clean the drum after each use.
16. **Tow Bar/Coupler** -This mixer uses a 2-inch coupler or pintle towbar.
17. **Safety Chain** -This mixer uses a 3/16-inch thick, 72-inches long zinc-plated safety chain. **ALWAYS** connect the safety chain when towing.
18. **Forklift Pockets** - When lifting of the mixer is required, use these fork lift pockets to lift the mixer. Remember to insert the forks of the forklift a minimum of 24 inches into the lift pockets.
19. **Chock Blocks** - Place these blocks (not included as part of the mixer package) under each mixer wheel to prevent rolling.

# EM-70 PLASTER/MORTAR MIXER — ENGINE COMPONENTS

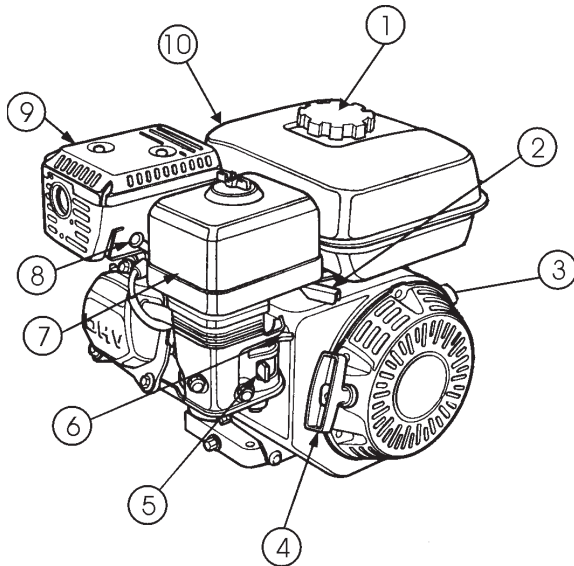

Figure 6. Engine Controls and Components

## Initial Servicing

The engine (Figure 6) must be checked for proper lubrication and filled with fuel prior to operation. Refer to the manufacturer's engine manual for instructions & details of operation and servicing.

1. **Fuel Filler Cap** – Remove this cap to add unleaded gasoline to the fuel tank. Make sure cap is tightened securely. **DO NOT** over fill.

**! DANGER** **Explosive Fuel Hazard**

Adding fuel to the tank should be done only when the engine is stopped and has had an opportunity to cool down. In the event of a fuel spill, **DO NOT** attempt to start the engine until the fuel residue has been completely wiped up, and the area surrounding the engine is dry.



2. **Throttle Lever** – Used to adjust engine RPM speed (lever advanced forward **SLOW**, lever back toward operator **FAST**).
3. **Engine ON/OFF Switch** – **ON** position permits engine starting, **OFF** position stops engine operations.
4. **Recoil Starter (pull rope)** – Manual-starting method. Pull the starter grip until resistance is felt, then pull briskly and smoothly.

5. **Fuel Valve Lever** – **OPEN** to let fuel flow, **CLOSE** to stop the flow of fuel.
6. **Choke Lever** – Used in the starting of a cold engine, or in cold weather conditions. The choke enriches the fuel mixture.
7. **Air Cleaner** – Prevents dirt and other debris from entering the fuel system. Remove wing-nut on top of air filter cannister to gain access to filter element.

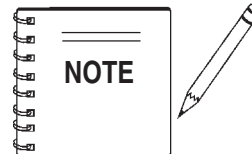

Operating the engine without an air filter, with a damaged air filter, or a filter in need of replacement will allow dirt to enter the engine, causing rapid engine wear.

**! WARNING** **Burn Hazard**

Engine components can generate extreme heat. To prevent burns, **DO NOT** touch these areas while the engine is running or immediately after operating. **NEVER** operate the engine with the muffler removed.



8. **Spark Plug** – Provides spark to the ignition system. Set spark plug gap to 0.6 - 0.7 mm (0.028 - 0.031 inch) Clean spark plug once a week.
9. **Muffler** – Used to reduce noise and emissions.
10. **Fuel Tank** – Holds unleaded gasoline. For additional information refer to engine owner's manual.



# EM-70 PLASTER/MORTAR MIXER — ELECTRIC MOTOR

## Electric Motor

For maintenance care and operation of the electric motor, refer to your electric motor instruction booklet furnished with the motor.

Protect the electric motor from dust as much as possible and keep ventilating openings clean.

<b>! CAUTION</b>	<b>Electric Motor Safety</b>
<p><b>DO NOT</b> spray water at any time on the <i>electric motor</i>.</p> <p><b>DO NOT</b> operate electric motor in a explosive environment.</p>	

The electric motor used in this mixer is a single-phase 1.5 HP motor. The input voltage requirement for this motor is either 115 or 230 VAC only.

## Electric Motor Connection

A 12-inch electrical cable (Figure 7) is provided with the electrical motor for hookup to a power source. Table 5 shows the required NEMA connector for the desired motor horsepower rating. In addition, Table 5 also shows the matching NEMA approved connector for the required extension cord.

<b>! CAUTION</b>	<b>Electric Motor Connections</b>
<p><b>ALWAYS</b> make certain that the power source required for the electric motor is <b>correct</b> and always use the correct NEMA configuration plug. <b>Failure</b> to supply the correct voltage to the motor can severely damage the motor.</p>	

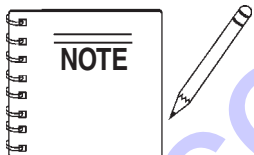

It is strongly recommended that all electrical wiring be done by a **licensed electrician**.

Special attention should be given to the electric switch as well as the over-and-under voltage protection devices as per regulations set forth in the local electrical safety code handbook

TABLE 5. ELECTRIC MOTOR WIRING INFORMATION

Motor Horsepower Rating	115-230 VAC - Single Phase	
	NEMA Plug Connector	Mating NEMA Receptacle Connector
1.5 HP (115 VAC)	L5-20P P/N EM940537	L5-20R P/N EM940538
1.5 HP (230 VAC)	L6-20P P/N 940539	L6-20R P/N 940540

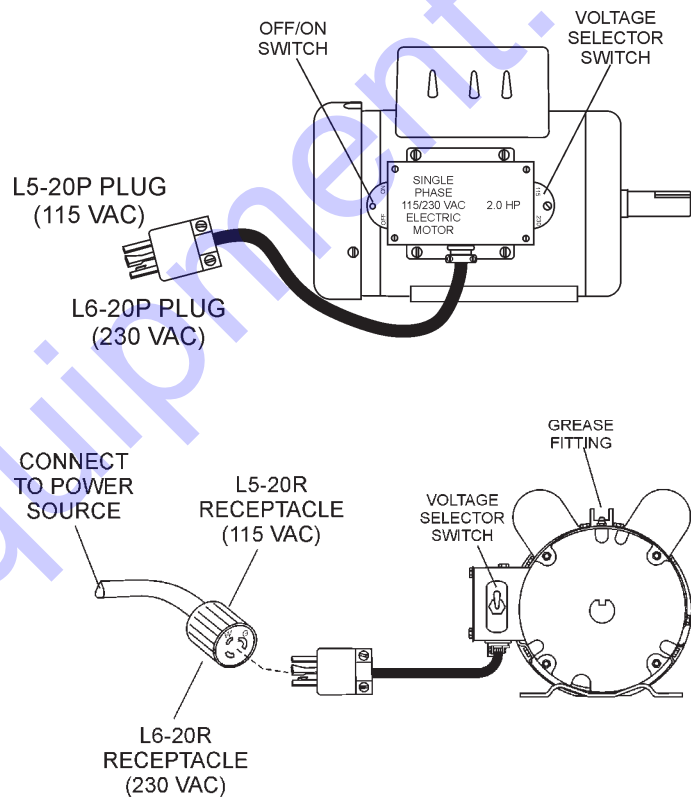

Figure 7. Single Phase Electric Motor With 12-inch Pigtail

# EM-70 PLASTER/MORTAR MIXER — ELECTRIC MOTOR

The motor supplied is wired for 115 VAC grounded operation. Make certain that the correct size grounded (3-wires) extension cord is used. See Table 6.

Motors can burn out when the line voltage falls 5% below the voltage rating of the motor. Failure to use proper voltage will cause the motor to overheat and actuate the overload switch.

If overload protection should actuate because of improper voltage or any other malfunction, turn the main switch on the motor to the **OFF** position and correct the problem, press the reset switch button, and turn the main switch to the **ON** position.

## Electric Motor Voltage Switch

1. **ALWAYS** make certain the motor switch is **OFF** and the power cord has been disconnected from the power source.
2. Remove the voltage lock-out bolt (Figure 7). Change the position of the **voltage change toggle switch** from 115 VAC to 230 VAC. The mixer is factory wired for 115 VAC operation.
3. Replace the voltage lock-out bolt.

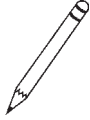
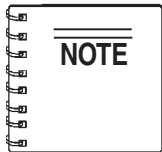

**Important!**, when changing the input voltage to the motor from 115 to 230 VAC the **plug** on the motor power cord must also be changed. See Table 4

TABLE 6. RECOMMENDED EXTENSION CORD SIZES

Model	Motor	Voltage	50 ft. (15.24 m)	75 ft. (22.86 m)	100 ft. (30.48 m)	200 ft. (60.96 m)
EM-70 (Electric)	1.5 HP	115	No. 12	No. 10	No. 8	No. 6
		230	No. 14	No. 12	No. 12	No. 8

# EM-70 MIXER — PADDLE BLADE ADJUSTMENT (STEEL DRUM)

Adjust paddles as shown in Figure 8a.

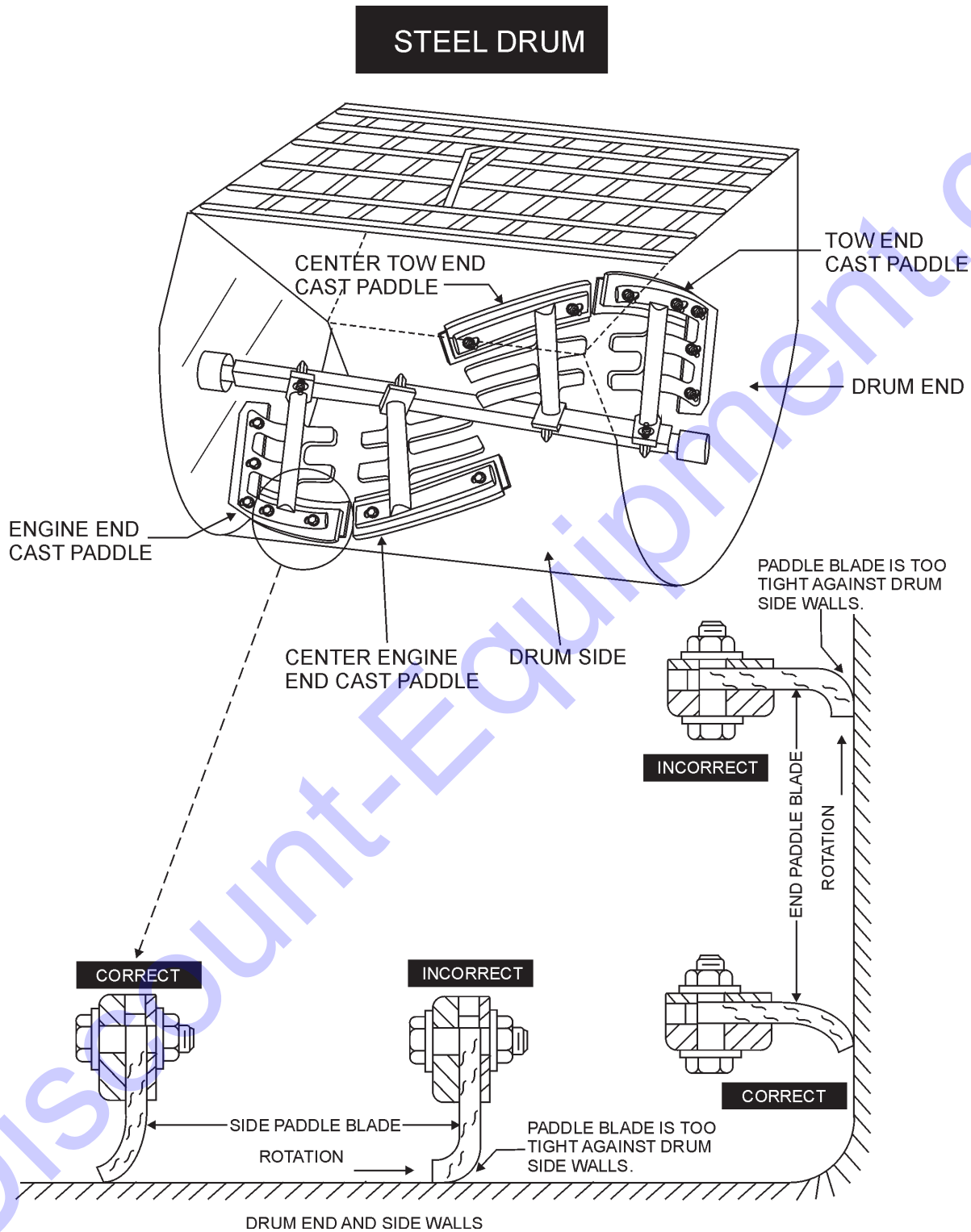

Figure 8a. Paddle Blade Adjustment (Steel Drum)

# EM-70 MIXER — PADDLE BLADE ADJUSTMENT (POLY DRUM)

Adjust paddles as shown in Figure 8b.

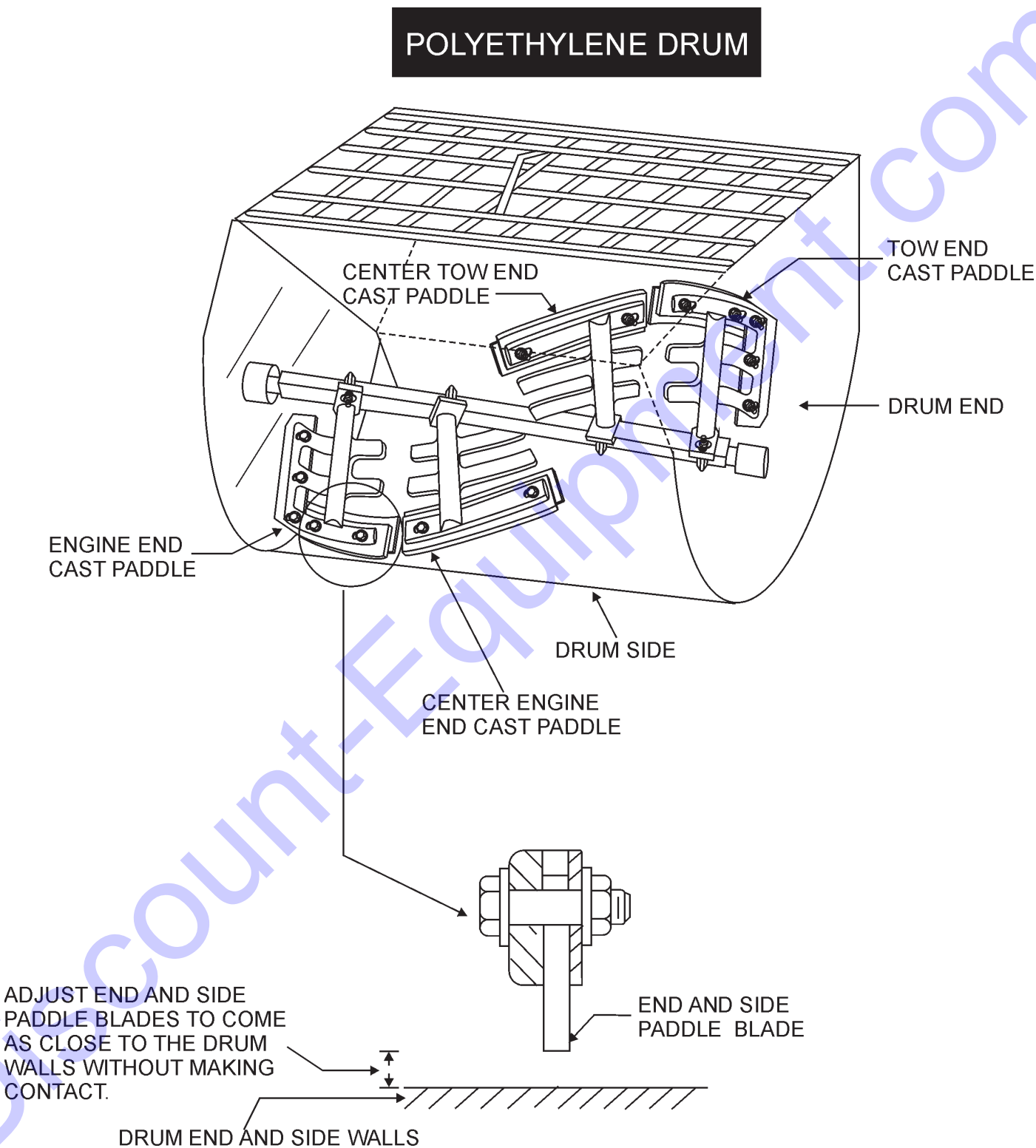

Figure 8b. Paddle Blade Adjustment (Poly Drum)

# EM-70 PLASTER/MORTAR MIXER — INSPECTION

## Before Starting

1. Read **all safety instructions** at the beginning of manual.
2. Clean the **mixer**, removing dirt and dust, particularly the engine cooling air inlet, carburetor and air cleaner.
3. Check the air filter for dirt and dust. If air filter is dirty, replace air filter with a new one as required.
4. Check carburetor for external dirt and dust. Clean with dry compressed air.
5. Check fastening nuts and bolts for tightness.

3. Insert and remove the dipstick without screwing it into the filler neck. Check the oil level shown on the dipstick.
4. If the oil level is low (Figure 10), fill to the edge of the oil filler hole with the recommended oil type (Table 7). Maximum oil capacity is 2.33 pints (1.09 liters)

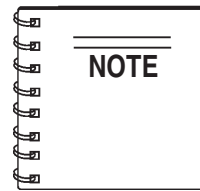

Reference manufacturer engine manual for specific servicing instructions.



**CAUTION**

**Eyesight and Hearing Protection**

**ALWAYS** wear approved eye and hearing protection before operating the mixer.





**CAUTION**

**Inspection & Maintenance Safety**

**NEVER** place hands or feet inside the engine guard cover while the engine is running. **ALWAYS** shut the engine down before performing any kind of maintenance service on the mixer.



## Engine Oil Check

1. To check the engine oil level, place the mixer on secure level ground with the engine stopped.
2. Remove the filler dipstick from the engine oil filler hole (Figure 9) and wipe it clean.

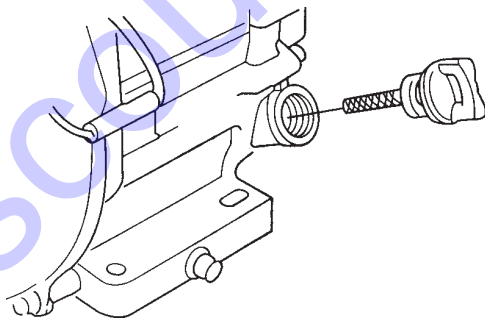

Figure 9. Engine Oil Dipstick (Removal)

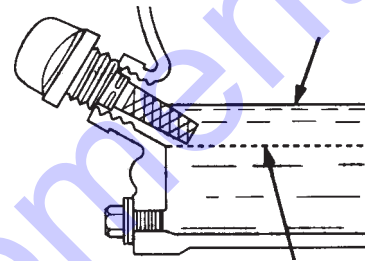

Figure 10. Engine Oil Dipstick (Oil Level)

TABLE 7. OIL TYPE		
Season	Temperature	Oil Type
Summer	25°C or Higher	SAE 10W-30
Spring/Fall	25°C~10°C	SAE 10W-30/20
Winter	0°C or Lower	SAE 10W-10

# EM-70 PLASTER/MORTAR MIXER — INSPECTION

## Fuel Check



### Explosive Fuel Hazard

If your mixer has a gasoline engine, determine if the engine fuel is low. If fuel is low, remove the fuel filler cap and fill with **unleaded** gasoline. Motor fuels are highly flammable and can be dangerous if mishandled. **DO NOT** smoke while refueling. **DO NOT** attempt to refuel the mixer if the engine is **hot!** or **running**.



1. Remove the gasoline cap located on top of fuel tank.
2. Visually inspect to see if fuel level is low. If fuel is low, replenish with unleaded fuel.
3. When refueling, be sure to use a strainer for filtration. **DO NOT** top-off fuel. Wipe up any spilled fuel.

## V-belt Check

A worn or damaged V-belt can adversely affect the performance of the mixer. If a V-belt is defective or worn simply replace the V-belt as outlined in the maintenance section of this manual.

## Blade Check

Check for worn or paddle blades. Make sure that all blades are adjusted properly. See blade adjustment procedure in this manual. Replace all defective or damaged blades immediately.

## Controls

### Start/Stop Switches

This mixer has been equipped with a start/stop switch for both the gasoline and electric motor mixers. These switches should be tested every time the engine or electric motor is started.

### Grease Fittings (Dumping Mechanism)

Check the zerk grease fittings at each end of the mixing drum. These grease fittings lubricate the dumping mechanism. If the dumping handle is stiff or hard to move lubricate these fittings.

# EM-70 PLASTER/MORTAR MIXER — START-UP PROCEDURE

This section is intended to assist the operator with the initial start-up of the EM-70 mixer (with gasoline engine or electric motor). It is extremely important that this section be read carefully before attempting to use the mixer in the field.



**DO NOT** use your mixer until this section is thoroughly understood.

## **! WARNING**

### General Safety

Failure to understand the operation of the EM-70 series mixers could result in **severe damage** to the mixer or **personal injury**.

See Figure 5 for the location of any control referenced in this manual.

## **! CAUTION**

### Respiratory Hazard



**NEVER** operate the mixer in a confined area or enclosed area structure that does not provide ample **free flow of air**.

### Start-up Procedure(Gasonline Engine)

The following steps outline the procedure for starting the engine. Depending on the type of engine employed in the mixer the steps may vary slightly. If your mixer has an electric motor disregard this section.

1. Move the fuel shut-off lever (Figure 11) to the **ON** position.

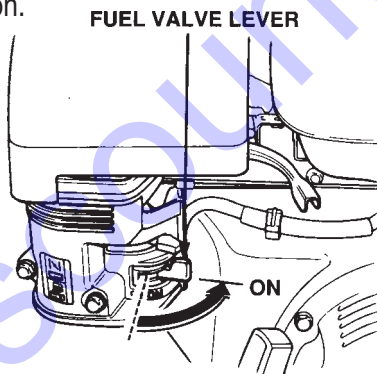

Figure 11. Fuel Shut-OFF Lever

2. To start a cold engine, move the choke lever (Figure 12) to the **CLOSED** position.

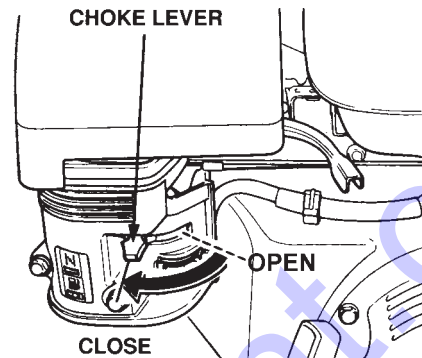

Figure 12. Choke Lever

3. Move the throttle lever (Figure 13) away from the slow position, about 1/3 of the way toward the fast position.

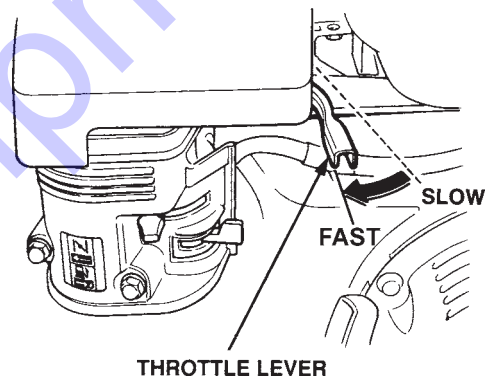

Figure 13. Throttle Lever



# EM-70 PLASTER/MORTAR MIXER — START-UP PROCEDURE

- Turn the engine switch (Figure 14) to the **ON** position.

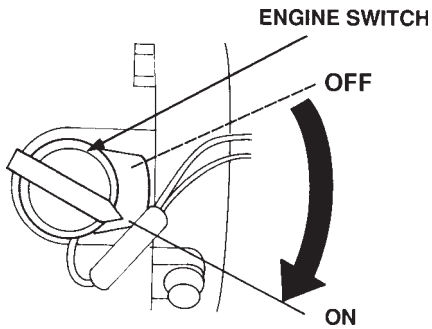

Figure 14. Engine ON/OFF Switch

- The main **start/stop** switch located on the engine cover is (Figure 15) is used to start and stop the engine. Pull this switch outward to start the engine.

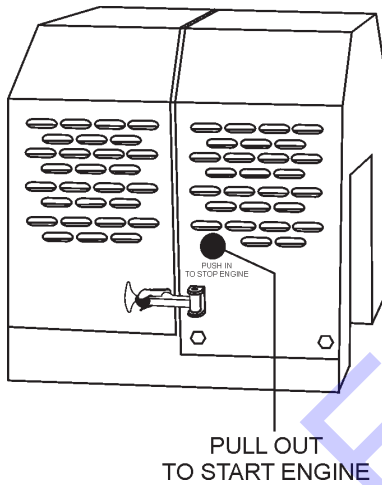

Figure 15. Start/Stop Switch (gasoline engine)

- Place the **belt slip lever** (Figure 16) in the **START/STOP** (disengaged) position.

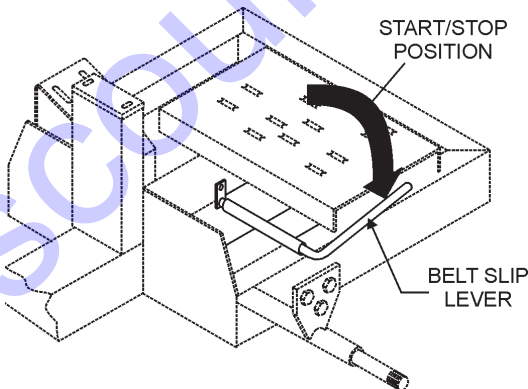

Figure 16. Belt Slip Lever (Start/Stop Position)

**CAUTION** Preventing Drum Tipping

Make certain the **drum lock pin** (Figures 17 and 18) is placed to the **RIGHT** (when viewing the mixer from the towpole end) of the drum stop block which is welded to the front side of the drum. Also make sure lock pin is fully engaged (locked). This will prevent the drum from tipping.

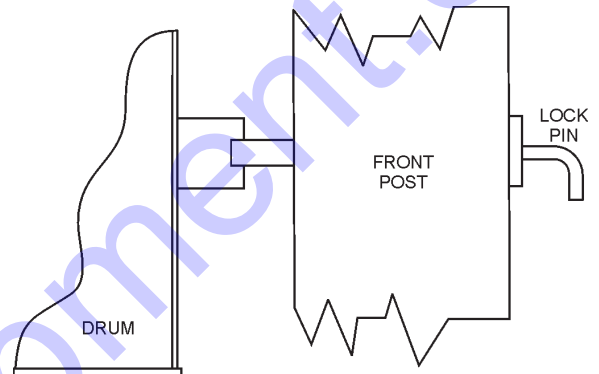

Figure 17. Drum Lock Pin (Side-View)

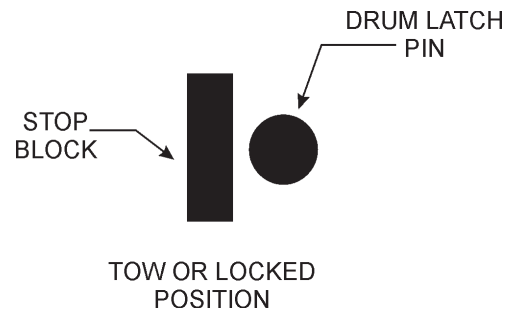

Figure 18. Drum Lock Pin (Right Position)

- Pull the **starter grip** (Figure 19) lightly until you feel resistance, then pull briskly. Return the starter grip gently.

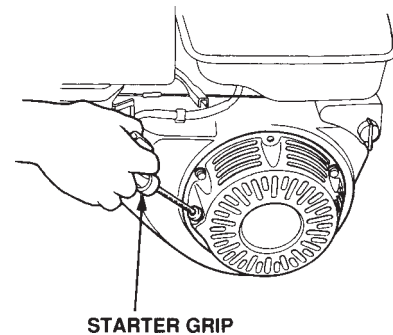

Figure 19. Starter Grip



# EM-70 PLASTER/MORTAR MIXER — START-UP/OPERATION PROCEDURES

- Place the belt slip lever (Figure 20) in the *mix* position. This will tilt the engine placing tension on the V-belts enabling the shaft to rotate.

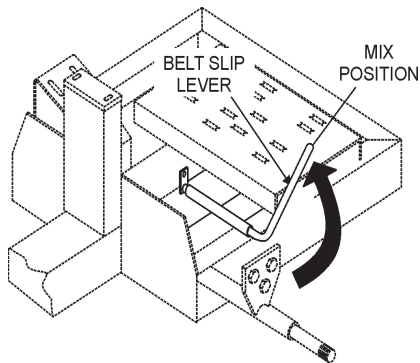

Figure 20. Belt Slip Lever (Mix Position)

## Start-up Procedure(Electric Motor)

- Using an adequate size extension cord (see Table 6), connect one end of the extension cord to the plug on the electric motor, connect the other end to the power source. Make sure the motor is configured for the proper operating voltage.
- Set the electric motor's **ON/OFF** switch (Figure 7) to the **ON** position.

## Mixing Dumping

- The paddle shaft inside the drum should be rotating at this time.
- Add a small amount water to the mixing drum.
- Lift the mixing bag compound onto the steel safety grate over the bag cutter and let the contents fall into the drum. Add more water if desired and mix compound to desired consistency.

- When charging, mixing, or dumping a batch of plaster or mortar the **drum lock pin** should be placed to the **left** (when viewing the mixer from the towpole end) of the drum stop block which is welded to the front side of the drum. See Figure 21.

This will allow the operator to use both hands on the drum handle during dumping. Please note that when the lock pin is placed to the left, the drum will be maintained in the vertical position as the paddles rotate. To discharge the material the operator should hold the dump handle with **both hands** and rotate the drum to discharge the desired amount of material.

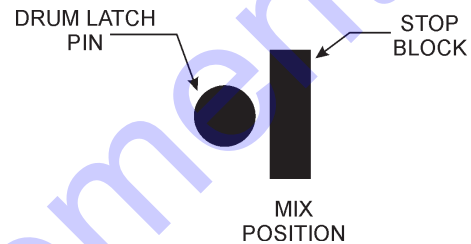

Figure 21. Drum Lock Pin (Left Position)

	<b>WARNING</b>	<b>Dump Handle Safety</b>
<p>Be sure to stand clear of the <b>dump handle</b> (Figure 22) when the mixer is operational. Any binding of material between the mixer blades and the drum will cause the drum handle to quickly move and could cause bodily harm.</p>		

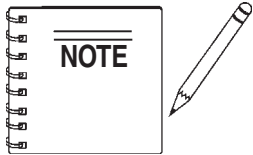

Figure 22. Stand Clear of Dump Handle

# EM-70 PLASTER/MORTAR MIXER — SHUT-DOWN PROCEDURES

## Stopping the Mixer (Gasoline Engine)

1. Place the **belt slip lever** in the **start/stop** position (Figure 20).
2. Push the main **start/stop** switch (Figure 15) inward to stop the engine.
3. Turn the fuel shut-off valve to the **OFF** position.
4. Disconnect the spark plug.
5. Clean mixer as referenced in the maintenance section of this manual.



It is recommended that the mixer's **Start/Stop switch** be used to stop the engine after every use.

Doing this will verify that the switch is working properly and presents no danger to the operator.

## Stopping the Mixer (Electric Motor)

1. Place the electric motor's **ON/OFF** switch (Figure 7) in the **OFF** position.
2. Disconnect the electric motor's extension cord from its power source.
3. Clean mixer as referenced in the maintenance section of this manual.

### **DANGER**

#### **DO NOT Disconnect the Start/Stop Switch**

**NEVER** disable or disconnect the start/stop switch. It is provided for operator safety. **Serious Injury** may result if it is disabled, disconnected or improperly maintained.

## EM-70 PLASTER/MORTAR MIXER — MAINTENANCE (ENGINE)

Use Table 8 as a general maintenance guideline when servicing your engine. For more detail engine maintenance information, refer to the engine owner's manual supplied with your engine.

**TABLE 8. ENGINE MAINTENANCE SCHEDULE**

DESCRIPTION (3)	OPERATION	BEFORE	FIRST MONTH OR 10 HRS.	EVERY 3 MONTHS OR 25 HRS.	EVERY 6 MONTHS OR 50 HRS.	EVERY YEAR OR 100 HRS.	EVERY 2 YEARS OR 200 HRS.
Engine Oil	CHECK	X					
	CHANGE		X				
Air Cleaner	CHECK	X					
	CHANGE			X (1)			
All Nuts & Bolts	Re-tighten If Necessary	X					
Spark Plug	CHECK-CLEAN				X		
	REPLACE						X
Cooling Fins	CHECK				X		
Spark Arrester	CLEAN					X	
Fuel Tank	CLEAN					X	
Fuel Filter	CHECK					X	
Idle Speed	CHECK-ADJUST					X (2)	
Valve Clearance	CHECK-ADJUST						X (2)
Fuel lines	CHECK	Every 2 years (replace if necessary) (2)					

(1) Service more frequently when used in **DUSTY** areas.

(2) These items should be serviced by your service dealer, unless you have the proper tools and are mechanically proficient. Refer to the HONDA Shop Manual for service procedures.

(3) For commercial use, log hours of operation to determine proper maintenance intervals.

# EM-70 PLASTER/MORTAR MIXER — MAINTENANCE (ENGINE)

## Maintenance

Perform the scheduled maintenance procedures as defined by Table 8 and below:

### DAILY

- Thoroughly remove dirt and oil from the engine and control area. Clean or replace the air cleaner elements as necessary. Check and retighten all fasteners as necessary. Check the gearbox for oil leaks. Repair or replace as needed.

### WEEKLY

- Remove the fuel filter cap and clean the inside of the fuel tank.
- Remove or clean the filter at the bottom of the tank.
- Remove and clean the spark plug (Figure 23), then adjust the spark gap to 0.024 ~0.028 inch (0.6~0.7 mm). This unit has electronic ignition, which requires no adjustments.

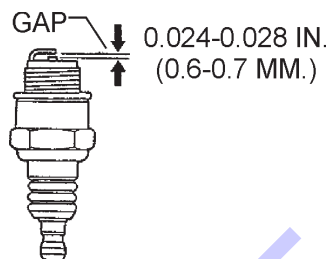

Figure 23. Spark Plug Gap

## ENGINE OIL

- Drain the engine oil when the oil is **warm** as shown in Figure 24.
- Remove the oil drain bolt and sealing washer and allow the oil to drain into a suitable container.
- Replace engine oil with recommended type oil as listed in Table 7. For engine oil capacity, see Table 2 (engine specifications). **DO NOT** overfill.
- Install drain bolt with sealing washer and tighten securely.

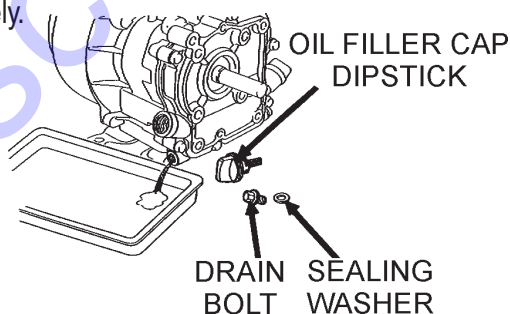

Figure 24. Engine Oil (Draining)

## ENGINE AIR CLEANER

- Remove the air cleaner cover and foam filter element as shown in Figure 25.
- Tap the paper filter element (Figure 25) several times on a hard surface to remove dirt, or blow compressed air [not exceeding 30 psi (207 kPa, 2.1 kgf/cm<sup>2</sup>)] through the filter element from the air cleaner case side. **NEVER** brush off dirt. Brushing will force dirt into the fibers. Replace the paper filter element if it is excessively dirty.
- Clean foam element in warm, soapy water or nonflammable solvent. Rinse and dry thoroughly. Dip the element in clean engine oil and completely squeeze out the excess oil from the element before installing.

**! DANGER** Explosive Hazard

**DO NOT** use gasoline as a cleaning solvent to avoid creating the risk of fire or an explosion.

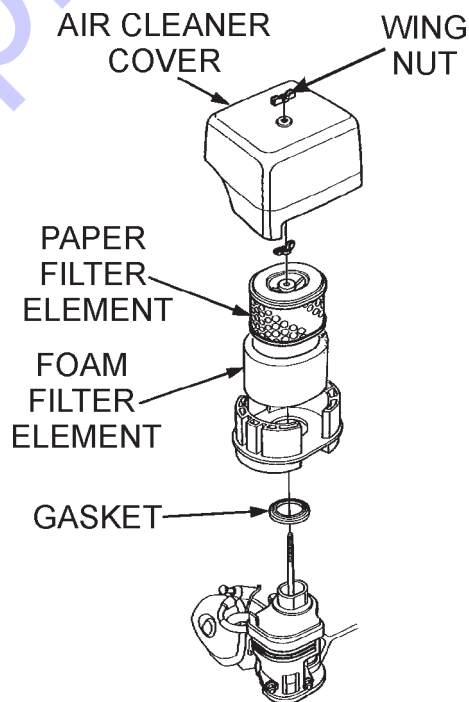

Figure 25. Engine Air Cleaner

# EM-70 PLASTER/MORTAR MIXER — MAINTENANCE (MIXER)

## Drum Head Seals

On each end of the mixing drum there is a drum head containing self-adjusting graphite seals. These seals consist of packing rings, split gland and spring activated adjusters. A properly maintained seal prevents material from working around the shaft, causing excessive wear. The following is the suggested procedure of maintenance for protection of the paddle shaft.

1. Keep drum head clean of material build up so the spring adjusters are free to work.
2. As the seals naturally wear, material will seep from the drum head. Tighten the adjusting nuts equally until a slight pressure is felt (Figure 26). The seals are now tight. This procedure should be done periodically as the seals leak.

TIGHTEN ADJUSTING NUTS  
AS SEALS WEAR AND LEAK

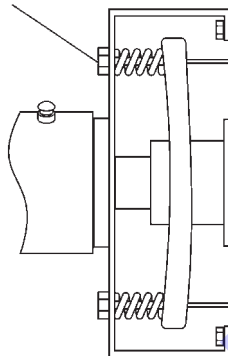

Figure 26. Drum Seal Adjusting Nuts

3. Once the pressure plate touches the drum, its time to replace the graphite seals (Figure 27).

REPLACE SEALS WHEN  
PLATE TOUCHES DRUM

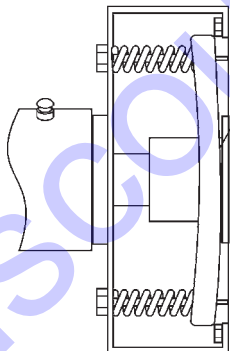

Figure 27. Replacing Drum Seals

## Drum Bearing Bracket Lubrication

There is 1 set of drum bearing brackets (Figure 28) that will require lubrication. These brackets are intended to make the drum rotate freely. Lubricate the grease fitting for each drum bearing bracket **every month or when the drum becomes difficult to position** using multi-purpose grade grease.

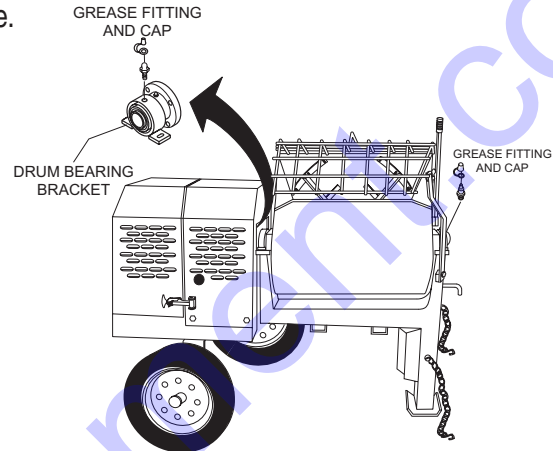

Figure 28. Grease Fittings (Dumping Mechanism)

## CAUTION

### Lubricating the Grease Fittings

**Failure** to lubricate the drum bearing grease fittings periodically will cause the dumping mechanism to stiffen, making the mixing drum hard to dump.

## Ball Socket and Clamp Face Maintenance

1. If the towing vehicle is equipped with a ball socket, smear socket periodically with multi-purpose grease. This will keep the ball socket well lubricated.
2. Periodically oil **pivot points** and **clamp face** surfaces of coupler with SAE 30 WT. motor oil.
3. When parking or storing your mixer. Keep the coupler off the ground so dirt will not build up in the ball socket.

# EM-70 PLASTER/MORTAR MIXER — MAINTENANCE (MIXER)

## Ball Socket and Clamp Face Maintenance

1. If the towing vehicle is equipped with a ball socket, smear socket periodically with multi-purpose grease. This will keep the ball socket well lubricated.
2. Periodically oil **pivot points** and **clamp face** surfaces of coupler with SAE 30 WT. motor oil.
3. When parking or storing your mixer. Keep the coupler off the ground so dirt will not build up in the ball socket.

## Countershaft Bearing Lubrication

There is 1 set of countershaft bearings (Figure 29) that will require lubrication. Lubricate the grease fitting for each countershaft bearing **every 40 hours of operation** using any grade lithium base grease.

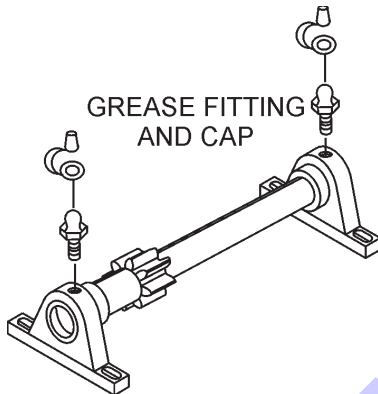

Figure 29. Grease Fittings (Countershaft)

## Wheel Bearings

1. After every 3 months of operation, remove the hub dust cap and inspect the wheel bearings (Figure 30). Once a year, or when required, **disassemble** the wheel hubs remove the old grease and repack the bearings forcing grease between rollers, cone and cage with a good grade of high speed wheel bearing grease (**never** use grease heavier than 265 A.S.T.M. penetration ("No. 2."))

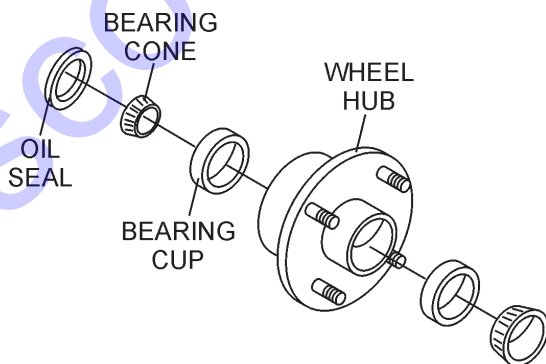

Figure 30. Wheel Hub and Bearings

2. Fill the wheel hub (Figure 30) with grease to the inside diameter of the outer races and also fill the hub grease cap. Reassemble the hub and mount the wheel. Then tighten the adjusting nut, at the same time turn the wheel in both directions, until there is a slight bind to be sure all the bearing surfaces are in contact.

Then back-off the adjusting nut 1/6 to 1/4 turn or to the nearest locking hole or sufficiently to allow the wheel to rotate freely within limits of .001" to .010" end play. Lock the nut at this position. Install the cotter pin and dust cap, and tighten all hardware.

## Main Gear and Drive Pinion Alignment

1. **Disconnect the spark plug wire** (gasoline engines). If mixer is equipped with an electric motor **remove power cord from AC power receptacle**. In addition make sure the clutch engagement lever is **dis-engaged** to relieve V-belt tension.
2. The countershaft and drive pinion are mounted on a slotted base. To align drive pinion with main gear, loosen the pillow block mounting bolts and move them until the necessary alignment has been made. Remember gears must be paralleled aligned not skewed.
3. Using your hand, slightly move (rock) the drive pulley back and forth to determine the amount of backlash. Insert feeler gauge between gears to determine backlash distance. Backlash should range between 0.007- 0.012 inches (Figure 31).

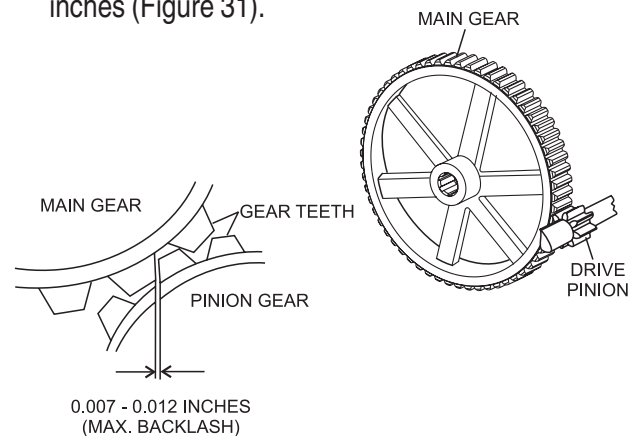

Figure 31. Drive Pinion and Main Gear (Backlash)



# EM-70 PLASTER/MORTAR MIXER — MAINTENANCE (MIXER)

## Inspect Tooth Contact between Main Gear and Drive Pinion

1. Coat 3 or 4 teeth at 3 different positions on the main gear with yellow paint.
2. Rotate the drive pulley in both directions.
3. Inspect the tooth pattern.
4. If gear teeth are not contacting properly (Figure 32), adjust pillow block to correct the problem.

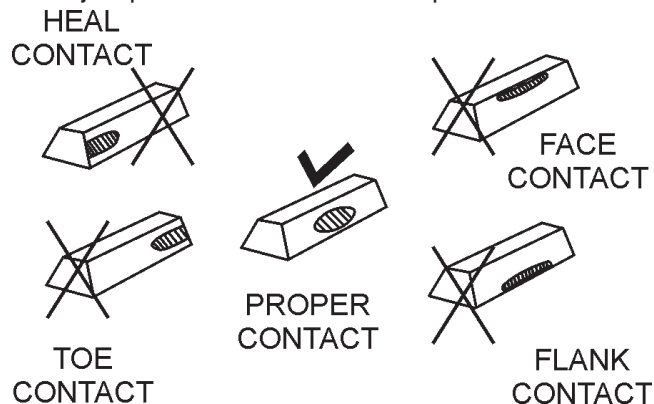

Figure 32. Gear Teeth Alignment

## Gear Lubrication

The surface of the pinion and main gear (Figure 33) should be very lightly greased.

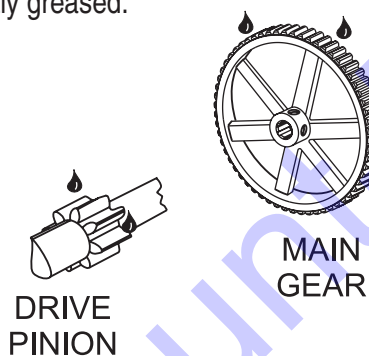
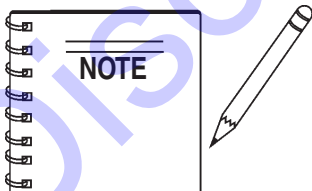

Figure 33. Pinion and Bull Gear Lubrication



Grease main and pinion gears every **250 hours of operation**. **IMPORTANT!** Avoid over-greasing.

Excess grease will accumulate contaminants and cause premature wear.

## Grease Fittings (Zerk) Maintenance (Electric Motor)

1. There are two grease (Figure 34) fittings at each end of the electric motor that will require lubrication. Lubricate these fittings about **every 16 months**.
2. Use Poleyrex EM (Exxon Mobil) or equivalent lubricant. Clean grease fitting, apply grease gun to fitting (1/2 shot). Remember too much grease or injecting grease too quickly can cause premature bearing failure. Slowly apply the recommended amount of grease, taking a minute or so to apply.

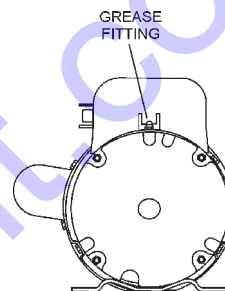

Figure 34. Grease Fittings Electric Motor

## Tires/Wheels/Lug Nuts

Tires and wheels are a very important and critical components of the trailer. When specifying or replacing the trailer wheels it is important the wheels, tires, and axle are properly matched.

WARNING

### Damaged Wheels

**DO NOT** attempt to repair or modify a wheel. **DO NOT** install an inter-tube to correct a leak through the rim. If the rim is cracked, the air pressure in the inter-tube may cause pieces of the rim to explode (break-off) with great force and can cause serious eye or bodily injury.

## Tires Wear/Inflation

Tire inflation pressure is the most important factor in tire life. Pressure should be checked cold before operation. **DO NOT** bleed air from tires when they are hot. Check inflation pressure weekly during use to insure the maximum tire life and tread wear.

WARNING







### Eyesight Hazard

**ALWAYS** wear safety glasses when removing or installing force fitted parts. Failure to comply may result in serious injury.

# EM-70 PLASTER/MORTAR MIXER — MAINTENANCE (MIXER)

Table 8 (Tire Wear Troubleshooting) will help pinpoint the causes and solutions of tire wear problems.

- After first road use, retorque all lug nuts in sequence. Check all wheel lug nuts periodically.

TABLE 9. TIRE WEAR TROUBLESHOOTING			
WEAR PATTERN	CAUSE	SOLUTION	
	Center Wear	Over Inflation	Adjust pressure to particular load per tire manufacturer.
	Edge Wear	Under Inflation	Adjust pressure to particular load per tire manufacturer.
	Side Wear	Loss of chamber or overloading.	Make sure load does not exceed axle rating. Align wheels.
	Toe Wear	Incorrect toe-in	Align wheels.
	Cupping	Out-of balance	Check bearing adjustment and balance tires.
	Flat Spots	Wheel lockup & tire skidding.	Avoid sudden stops when possible and adjust brakes.

## Lug Nut Torque Requirements

It is extremely important to apply and maintain proper wheel mounting torque. Be sure to use only the fasteners matched to the cone angle of the wheel. Proper procedure for attachment of the wheels is as follows:

- Start all wheel lug nuts by hand.
- Torque all lug nuts in sequence. See Figure 35. **DO NOT** torque the wheel lug nuts all the way down. Tighten each lug nut in 3 separate passes as defined by Table 9.

TABLE 10. TIRE TORQUE REQUIREMENTS			
Wheel Size	First Pass FT-LBS	Second Pass FT-LBS	Third Pass FT-LBS
12"	20-25	35-40	50-65
13"	20-25	35-40	50-65
14"	20-25	50-60	90-120
15"	20-25	50-60	90-120
16"	20-25	50-60	90-120

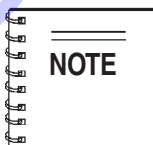

**NEVER!** use an pneumatic air gun to tighten wheel lug nuts.

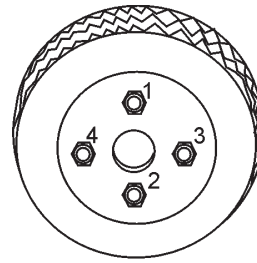

4-LUG NUTS

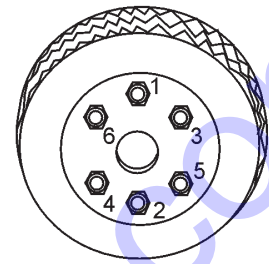

6-LUG NUTS

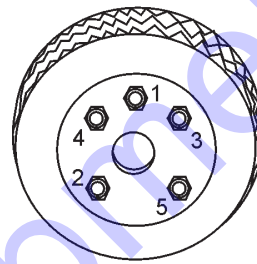

5-LUG NUTS

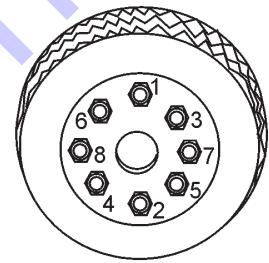

8-LUG NUTS

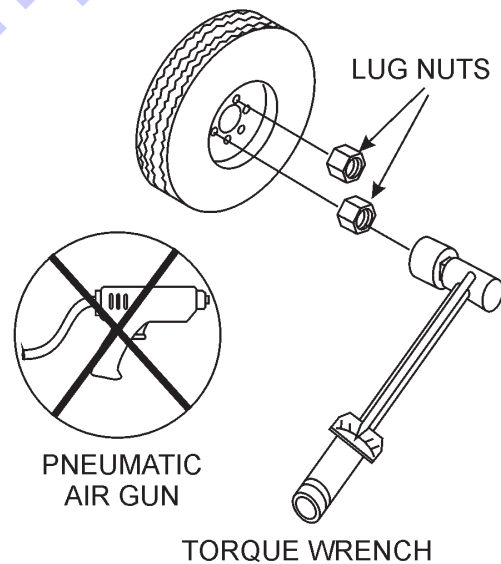

Figure 35. Wheel Lug Nuts Tightening Sequence



# EM-70 PLASTER/MORTAR MIXER — MAINTENANCE (MIXER)

## Suspension

The rigid type axle and associated hardware (Figure 35) should be periodically inspected for signs of excessive wear, elongation of bolt holes, and loosening of fasteners. Replace all damaged parts immediately.

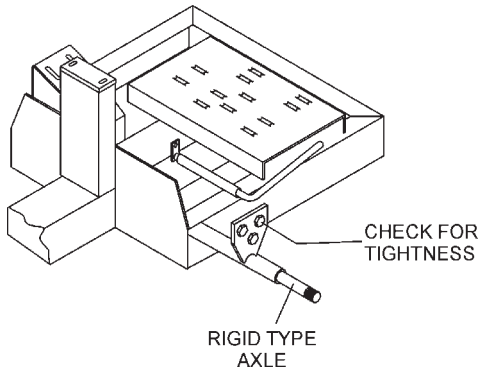

Figure 36. Axle Support Components

## Mixer Cleaning

1. **ALWAYS disconnect the spark plug wire** (gasoline engines) before cleaning the inside of the drum. If mixer is equipped with an electric motor **remove power cord from AC power receptacle**. In addition make sure the clutch engagement lever is **dis-engaged**.
2. Make sure the rear section of the safety grate is connected to the mixing drum.
3. At the end of each day's operation, place mixer drum in an upright position and spray inside of tub immediately with water to prevent lumps of dried mortar or plaster from forming and contamination of future batches, **DO NOT** allow a buildup of materials to form on the blades or anywhere inside the drum.
4. Rotate mixer to dump position and remove debris.
5. **Thoroughly clean** the entire mixer, wheels, cabinet and frame.
6. **NEVER!** pour or spray water over the engine or electric motor (Figure 37).

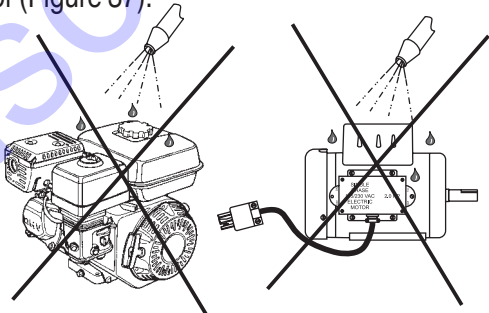

Figure 37. No Spraying of Water

## WARNING

Keep Hands  
Clear of Drum!

When rotating the mixing drum from the dump position to the upright position, **keep hands clear of safety grate**. The possibility exists of hands or fingers being crushed (Figure 38).



Figure 38. Safety Grate (Crush Hazard)

7. When cleaning of the entire mixer is done, return mixing drum to an upright position.

## Mixer Storage

For storage of the mixer for over 30 days, the following is recommended:

- Drain the fuel tank completely, or add STA-BIL to the fuel.
- Run the engine until the fuel is completely consumed.
- Completely drain used oil from the engine crankcase and fill with fresh clean oil, then follow the procedures described in the engine manual for engine storage.
- Clean the entire mixer and engine compartment.
- Place the mixing drum in the down position (mouth facing downward).
- Cover the mixer and place it a clean dry area, that is protected from harsh elements.

# EM-70 PLASTER/MORTAR MIXER — TROUBLESHOOTING (ENGINE)

Practically all breakdowns can be prevented by proper handling and maintenance inspections, but in the event of a breakdown, please take a remedial action following the diagnosis based on the **Engine**, **Mixer** and **Electric Motor** Troubleshooting (Tables 11, 12 and 13) information shown below and on the proceeding pages. If the problem cannot be remedied, please leave the unit just as it is and consult or company's service department.

**TABLE 11. ENGINE TROUBLESHOOTING**

SYMPTOM	POSSIBLE PROBLEM	SOLUTION
Poor starting	Inspect carburetor to see if fuel is reaching it?	Check fuel line
	No Fuel?	Add Fuel
	Water in fuel tank?	Flush or replace fuel tank.
	Fuel filter clogged?	Replace fuel filter
	Stuck carburetor?	Check float mechanism.
	Spark plug is red?	Spark plug is fouled. Check transistor ignition unit.
	Spark plug is blue-white?	Insufficient compression, injected air leaking. Carburetor jets are clogged (overflow).
	No spark present at tip of spark plug?	Transistor ignition unit broken, high voltage cord cracked or broken. Start/Stop switch broken. Replace spark plug if fouled.
	No oil?	Add oil as required.
	Oil pressure alarm lamp blinks upon starting?	Check Automatic shutdown circuit "oil sensor".
Insufficient power output "no compression"	Engine will not turn over?	Replace cylinder and piston and if necessary axel joint.
	Cylinder head connecting bolts loose?	Tighten cylinder head connecting bolts.
	Cylinder head gasket damaged?	Replace cylinder head gasket.
	Malfunction of valve seat?	Re-seat valves.
	Spark plug is loose?	Replace spark plug.
	Worn piston rings?	Replace piston rings.
Insufficient power output "compression"	Malfunction in air-cleaner system, air filter clogged?	Clean or replace air filter.
	Air leaking in from interface between carburetor and cylinder head?	Tighten bolts between carburetor and cylinder head. Replace cylinder head gasket.
	Malfunction in fuel system?	Clean or replace fuel filter. Clean or replace carburetor. Check carburetor float.

# EM-70 PLASTER/MORTAR MIXER — TROUBLESHOOTING (ENGINE)

**TABLE 11. ENGINE TROUBLESHOOTING (CONTINUED)**

SYMPTOM	POSSIBLE PROBLEM	SOLUTION
Insufficient power output "compression" and overheats	Malfunction in cooling fan?	Check or replace cooling fan.
	Air in-take filter clogged?	Clean or replace air in-take filter.
Burns to much fuel	Over accumulation of exhaust products?	Clean and check valves. Check muffler, replace if necessary.
	Wrong spark plug?	Replace spark plug with manufactures suggested type spark plug.
Exhaust color is continiously "WHITE"	Lubricating oil is wrong viscosity?	Replace lubricating oil with correct viscosity.
	Worn rings?	Replace rings
Exhaust color is continiously "BLACK"	Air cleanner clogged?	Clean or replace air cleaner.
	Choke valve has not been set to the correct position?	Adjust choke valve to the correct position.
	Carburetor defective, seal on carburetor broken?	Replace carburetor or seal.
	Poor carburetor adjustment "engine runs too rich?"	Adjust carburetor.

# EM-70 PLASTER/MORTAR MIXER — TROUBLESHOOTING (MIXER/ELECTRIC MOTOR)

**TABLE 12. MIXER TROUBLESHOOTING**

SYMPTOM	POSSIBLE PROBLEM	SOLUTION
Blades will not rotate.	Worn or defective V-belt?	Replace V-belt.
	Adjustment lever mis-aligned?	Check position of adjustment lever. Adjust if necessary.
Material leaking from drum ends.	Worn or defective paddle shaft seals?	Replace seals.
Drum difficult to discharge (tilt)	Defective or worn drum support brackets?	Apply grease to bracket or replace.
	Blades adjusted too tight.	Adjust blades until they almost touch side walls of drum.

**TABLE 13. ELECTRIC MOTOR TROUBLESHOOTING**

SYMPTOM	POSSIBLE PROBLEM	SOLUTION
Blades will not rotate.	No voltage to motor?	Check power source.
	Defective extension cord?	Replace extension cord.
	Defective motor ON/OFF switch?	Replace switch.
	Defective motor windings?	Repair windings or replace windings.

# EM-70 PLASTER/MORTAR MIXER — WIRING DIAGRAM (ELECTRIC MOTOR)

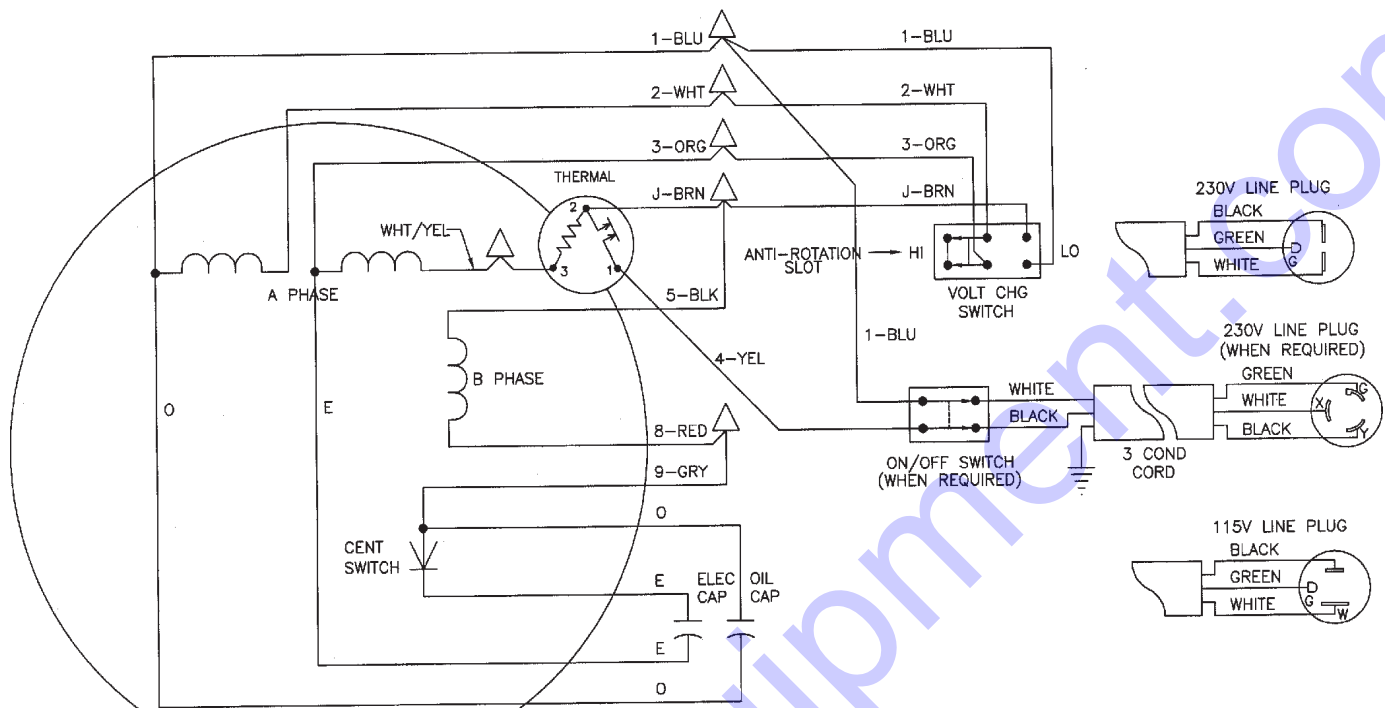

**NOTES:**

1. CONNECTIONS ARE SHOWN FOR CCW ROTATION FACING END OPPOSITE SHAFT EXTENSION (STD). FOR CW ROTATION, INTERCHANGE 5 AND 8 LEADS.
2. MULTIPLE CAPACITORS ARE CONNECTED IN PARALLEL UNLESS OTHERWISE SPECIFIED.
3. USE 2PDT VOLTAGE CHANGE SWITCH. CONTACTS ARE SHOWN IN HIGH VOLT POSITION. VIEW IS FROM TERMINAL SIDE.
4. LEAD COLORS ARE OPTIONAL. LEADS MUST ALWAYS BE NUMBERED AS SHOWN.

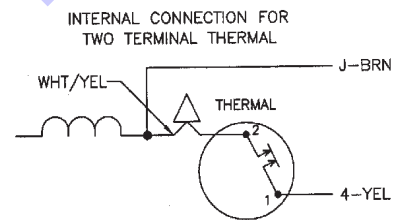

**Figure 39. Electric Motor Wiring Diagram**

# OPERATIONS MANUAL



[www.discount-equipment.com](http://www.discount-equipment.com)



**TO PURCHASE THIS PRODUCT PLEASE CONTACT US**



**Equipment Financing and  
Extended Warranties Available**



**Discount-Equipment.com is your online resource for  
commercial and industrial quality parts and equipment sales.**

**561-964-4949**

**visit us on line @ [www.discount-equipment.com](http://www.discount-equipment.com)**

Select an option below to find your Equipment

**Search by Manufacturer**

**Search by Product Type**

**Request a Quote**

We sell worldwide for the brands: Genie, Terex, JLG, MultiQuip, Mikasa, Essick, Whiteman, Mayco, Toro Stone, Diamond Products, Generac Magnum, Airman, Haulotte, Barreto, Power Blanket, Nifty Lift, Atlas Copco, Chicago Pneumatic, Allmand, Miller Curber, Skyjack, Lull, Skytrak, Tsurumi, Husquvarna Target, Stow, Wacker, Sakai, Mi-T-M, Sullair, Basic, Dynapac, MBW, Weber, Bartell, Bennar Newman, Haulotte, Ditch Runner, Menegotti, Morrison, Contec, Buddy, Crown, Edco, Wyco, Bomag, Laymor, EZ Trench, Bil-Jax, F.S. Curtis, Gehl Pavers, Heli, Honda, ICS/PowerGrit, IHI, Partner, Imer, Clipper, MMD, Koshin, Rice, CH&E, General Equipment, Amida, Coleman, NAC, Gradall, Square Shooter, Kent, Stanley, Tamco, Toku, Hatz, Kohler, Robin, Wisconsin, Northrock, Oztec, Toker TK, Rol-Air, APT, Wylie, Ingersoll Rand / Doosan, Innovatech, Con X, Ammann, Mecalac, Makinex, Smith Surface Prep, Small Line, Wanco, Yanmar