

BOMMAG

FAYAT GROUP

Operating instructions Maintenance instructions

Original operating instructions

BVP 10/36 / BVP 18/45

S/N 861 834 03 > / S/N 861 834 04 >

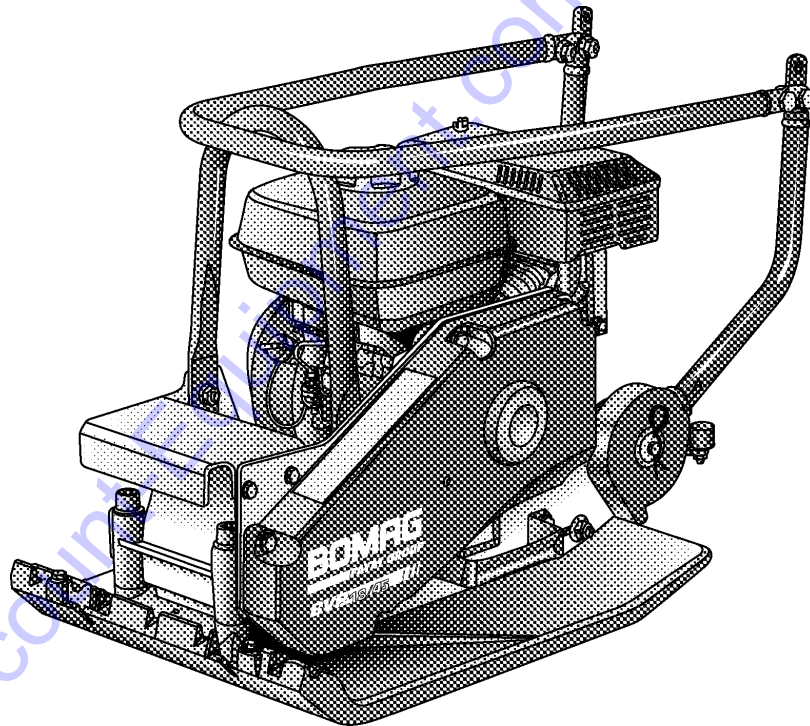

Forward marching vibratory plate

**Discount
Equipment**

www.discount-equipment.com

PARTS FINDER

**Search Website
by Part Number**



**Search Manual
Library For Parts
Manual & Lookup Part
Numbers – Purchase
or Request Quote**

Search Manuals

Enter your information to help us find the right parts manual for your machine.

* Brand:

* Model:

* Serial:

* Part Number:

SEARCH

**Can't Find Part or
Manual? Request Help
by Manufacturer,
Model & Description**

Parts Order Form

Please fill in the following information to help us find the right part for your machine.

Manufacturer:	<input type="text"/>
Model:	<input type="text"/>
Description:	<input type="text"/>
Part Number:	<input type="text"/>
Quantity:	<input type="text"/>
Notes:	<input type="text"/>

Submit

Discount-Equipment.com is your online resource for quality parts & equipment.

Florida: **561-964-4949** Outside Florida TOLL FREE: **877-690-3101**

Need parts?

Click on this link: <http://www.discount-equipment.com/category/5443-parts/> and choose one of the options to help get the right parts and equipment you are looking for. Please have the machine model and serial number available in order to help us get you the correct parts. If you don't find the part on the website or on one of the online manuals, please fill out the request form and one of our experienced staff members will get back to you with a quote for the right part that your machine needs.

We sell worldwide for the brands: Genie, Terex, JLG, MultiQuip, Mikasa, Essick, Whiteman, Mayco, Toro Stone, Diamond Products, Generac Magnum, Airman, Haulotte, Barreto, Power Blanket, Nifty Lift, Atlas Copco, Chicago Pneumatic, Allmand, Miller Curber, Skyjack, Lull, Skytrak, Tsurumi, Husquvarna Target, Stow, Wacker, Sakai, Mi-T-M, Sullair, Basic, Dynapac, MBW, Weber, Bartell, Bennar Newman, Haulotte, Ditch Runner, Menegotti, Morrison, Contec, Buddy, Crown, Edco, Wyco, Bomag, Laymor, EZ Trench, Bil-Jax, F.S. Curtis, Gehl Pavers, Heli, Honda, ICS/PowerGrit, IHI, Partner, Imer, Clipper, MMD, Koshin, Rice, CH&E, General Equipment, Amida, Coleman, NAC, Gradall, Square Shooter, Kent, Stanley, Tamco, Toku, Hatz, Kohler, Robin, Wisconsin, Northrock, Oztec, Toker TK, Rol-Air, APT, Wylie, Ingersoll Rand / Doosan, Innovatech, Con X, Ammann, Mecalac, Makinex, Smith Surface Prep, Small Line, Wanco, Yanmar

If the machine is equipped with a battery :

CALIFORNIA
Proposition 65 Warning

Battery posts, terminals and related accessories contain lead and lead compounds, chemicals known to the State of California to cause cancer and birth defects or other reproductive harm.
Wash hands after handling.

If the machine is equipped with a diesel engine :

CALIFORNIA
Proposition 65 Warning

The engine exhaust and some of its constituents are known to the state of California to cause cancer, birth defects, and other reproductive harm.

Go to Discount-Equipment.com to order your parts

These BOMAG machines are products from the wide range of BOMAG machines for earth work, asphalt and refuse compaction as well as stabilizers/recyclers.

BOMAG's vast experience in connection with state-of-the-art production and testing methods, such as lifetime tests of all important components and highest quality demands guarantee maximum reliability of your machine.

Using these instructions will

- help you to become familiar with the machine.
- avoid malfunctions caused by unprofessional operation.

Compliance with the maintenance instructions will

- enhance the reliability of the machine on construction sites,
- prolong the lifetime of the machine,
- reduce repair costs and downtimes.

BOMAG will not assume liability for the function of the machine

- if it is handled in a way not complying with the usual modes of use,
- if it is used for purposes other than those mentioned in these instructions.

No warranty claims can be lodged in case of damage resulting from

- operating errors,
- insufficient maintenance and
- wrong fuels and lubricants.

Please note!

This manual was written for operators and maintenance personnel on construction sites.

You should only operate the machine after you have been instructed and in compliance with these instructions.

Strictly observe the safety regulations.

Please observe also the guidelines of the Civil Engineering Liability Association "Safety Rules for the Operation of Road Rollers and Soil Compactors" and all relevant accident prevention regulations.

For your own personal safety you should only use original spare parts from BOMAG.

In the course of technical development we reserve the right for technical modifications without prior notification.

These operating and maintenance instructions are also available in other languages.

Apart from that, the spare parts catalogue is available from your BOMAG dealer against the serial number of your machine.

Your BOMAG dealer will also supply you with information about the correct use of our machines in soil and asphalt construction.

The above notes do not constitute an extension of the warranty and liability conditions specified in the general terms of business of BOMAG.

We wish you successful work with your BOMAG machine.

BOMAG GmbH

Printed in Germany

Copyright by BOMAG

Foreword

Please fill in

.....
Machine type (Fig. 1)

.....
Serial No. (Fig. 1 and 2)

.....
Engine type (Fig. 3)

.....
Engine No. (Fig. 3)

i Note

Fill in the above listed data when receiving the machine.

Upon receipt of the machine our organization will instruct you about correct operation and maintenance.

Please observe strictly all safety regulations and notes on potential dangers!

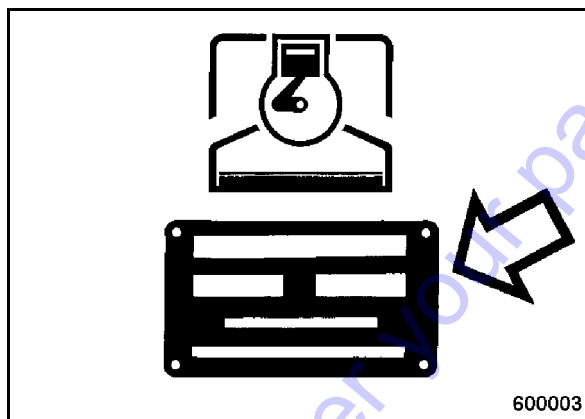

Fig. 1

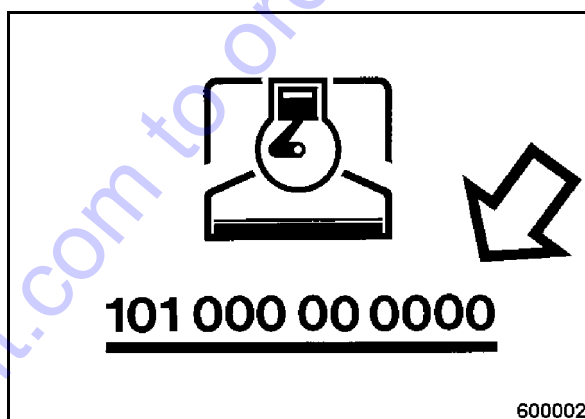

Fig. 2

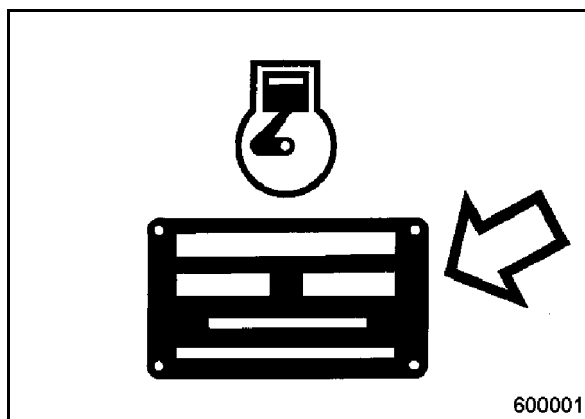

Fig. 3

Technical Data	7
Safety regulations	11
Indicators and Controls	19
3.1 General notes	20
3.2 Description of indicators and control elements	20
Operation	23
4.1 General	24
4.2 Tests before taking into operation	24
4.3 Mounting the steering bow	25
4.4 Starting the engine	25
4.5 Work/operation	28
4.6 Switching on the water sprinkling system	29
4.7 Switching the motor off	29
4.8 Loading/transport	30
Maintenance	31
5.1 General notes on maintenance	32
5.2 Fuels and lubricants	33
5.3 Table of fuels and lubricants	34
5.4 Running-in instructions	35
5.5 Maintenance table	36
5.6 Cleaning the machine	37
5.7 Check the engine oil level	37
5.8 Check the fuel level	38
5.9 Filling the water tank	38
5.10 Cleaning the air filter	39
5.11 Clean the cooling fins and the cooling air intake openings	41
5.12 Change the engine oil	43
5.13 Checking, cleaning the spark plug	44
5.14 Cleaning the fuel sludge filter	45
5.15 Checking the oil level in the vibrator housing	45
5.16 Checking the V-belt, tightening, replacing if necessary	46
5.17 Checking, adjusting the valve clearance	47
5.18 Cleaning the fuel screen	48
5.19 Changing the oil in the vibrator housing	49
5.20 Check the rubber buffers	50
5.21 Change the air filter	51
5.22 Flushing the water sprinkler system	52
5.23 Tightening the screws	52
5.24 Engine conservation	53
Trouble shooting	55
6.1 General Troubleshooting Instructions	56

Table of Contents

6.2 Engine Troubleshooting Chart

57

Go to Discount-Equipment.com to order your parts

1 Technical Data

Go to Discount-Equipment.com to order your parts

Technical Data

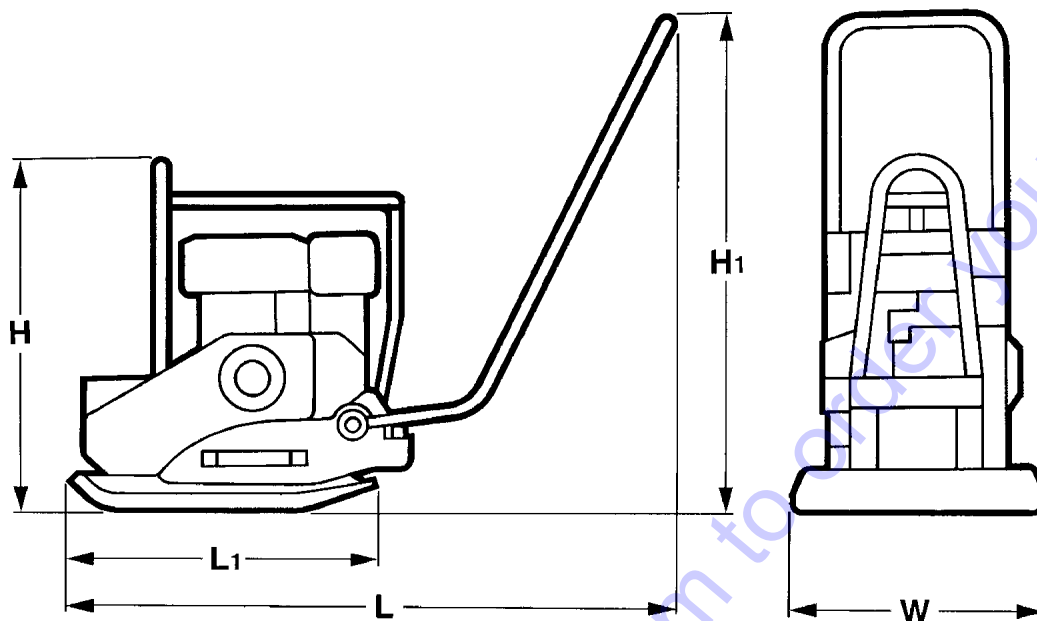

220014

Fig. 4

Dimensions in mm	H	H1	L	L1	W
BVP 10/36	535	915	1115	558	360
BVP 18/45	535	915	1115	558	450

*

BVP 10/36 **BVP 18/45**

Weights

Operating weight (CECE)	kg	83	91
Basic weight	kg	82	90

Travel characteristics

Working speed max.	m/min	25	25
Max. gradability (depending on soil)	%	30	30

Drive

Engine manufacturer		Honda	Honda
Type		GX 120	GX 160
Cooling		Air	Air
Working cycles		4	4
Number of cylinders		1	1
Rated power ISO 9249	kW	2.6	3.6
Rated speed	rpm	3600	3600
Drive system		mech.	mech.

*

BVP 10/36

BVP 18/45

Vibration system

Frequency	Hz	90	90
Centrifugal force	kN	10	18

Filling capacities

Fuel (gasoline)	l	2.5	3.6
Water tank (water sprinkling system)	l	7	7
Engine oil	l	0.6	0.6

* The right for technical modifications remains reserved

Go to Discount-Equipment.com to order your parts

Technical Data

The following noise and vibration data acc. to

- EC Machine Regulation edition 2006/42/EC
- the noise regulation 2000/14/EG, noise protection guideline 2003/10/EC
- Vibration Protection Regulation 2002/44/EC

were determined during conditions typical for this type of equipment and by application of harmonized standards.

During operation these values may vary because of the existing operating conditions.

Noise value

Sound pressure level on the place of the operator:

BVP 10/36: $L_{pA} = 93$ dB(A), determined acc. to ISO 11204 and EN 500

BVP 18/45: $L_{pA} = 95$ dB(A), determined acc. to ISO 11204 and EN 500

Guaranteed sound power level:

BVP 10/36: $L_{WA} = 105$ dB(A), determined acc. to ISO 3744 and EN 500

BVP 18/45: $L_{WA} = 107$ dB(A), determined acc. to ISO 3744 and EN 500

Danger

Loss of hearing!

Wear your personal noise protection means (ear defenders) before starting operation.

Vibration value

Hand-arm vibration:

Vector total of the weighted effective acceleration in three orthogonal directions:

Weighted total vibration value

BVP 10/36: $a_{hv} = 3.6$ m/s² on crushed rock determined acc. to ISO 5349 and EN 500

BVP 18/45: $a_{hv} = 7.8$ m/sec² on crushed rock determined acc. to ISO 5349 and EN 500

Caution

Observe the daily vibration load (Industrial safety acc. to 2002/44/EEC).

2 Safety regulations

Go to Discount-Equipment.com to order your parts

General

This BOMAG machine has been built in compliance with the latest technical standard and complies with the applicable regulations and technical rules. However, dangers for persons and property may arise from this machine, if:

- it is used for purposes other than the ones it is intended for,
- it is operated by untrained personnel,
- it is changed or converted in an unprofessional way,
- the safety instructions are not observed.

Each person involved in the operation, maintenance and repair of the machine must therefore read and comply with these safety regulations. If necessary, this must be confirmed by obtaining the signature of the customer.

Furthermore, the following obviously also applies:

- applicable accident prevention instructions,
- generally accepted safety and road traffic regulations,
- country specific safety regulations. It is the duty of the operator to be acquainted with these instructions and to apply these accordingly. This applies also for local regulations concerning different types of handling work. Should the recommendations in these instructions be different from the regulations valid in your country, you must comply with the safety regulations valid in your country.

Intended use

This machine must only be used for:

- Compaction of all types of soils
- Repair work on all types of soil
- Paving of walkways
- Work in trenches
- Underfilling and compaction of hard shoulders

Unintended use

Dangers may arise from the machine when it is used for purposes other than the one it is intended for.

Any danger caused by intended use is the sole responsibility of the customer or driver/operator, the manufacturer cannot be made liable.

Examples for unintended use are:

- Dragging the machine along as a measure of transportation
- Throwing the machine off the transport vehicle
- Attaching an additional weight to the machine

It is not permitted to stand on the machine while working.

Any transport ropes fastened to the machine must be removed before operation.

Starting and operation of the machine in explosive environments and in underground mining is prohibited.

Remaining dangers, remaining risks

Despite careful work and compliance with standards and regulations it cannot be ruled out that further dangers may arise when working with and handling the machine.

Both the machine as well as all other system components comply with the currently valid safety regulations. Nevertheless, remaining risks cannot be ruled out completely, even when using the machine for the purpose it is intended for and following all information given in the operating instructions.

A remaining risk can also not be excluded beyond the actual danger zone of the machine. Persons remaining in this area must pay particular attention to the machine, so that they can react immediately in case of a possible malfunction, an incident or failure etc.

All persons remaining in the area of the machine must be informed about the dangers that arise from the operation of the machine.

Regular safety inspections

Have the machine inspected by an expert (properly trained person) once every year.

Who is allowed to work with the machine?

The machine must only be operated by trained and authorized persons who are at least 18 years of age. The responsibilities for the operation of the

machine must be clearly specified and complied with.

Persons under the influence of alcohol, medication or drugs must not operate, service or repair the machine.

Maintenance and repair tasks require specific knowledge and must therefore only be carried out by trained and qualified personnel.

Conversions and alterations to the machine

Unauthorized conversions to the machine are prohibited for safety reasons.

Original parts and accessories have been specially designed for this machine. We wish to make expressly clear that we have not tested or authorized any original parts or special equipment not supplied by us. The installation and/or use of such products can impair the active and/or passive driving safety. The manufacturer expressly excludes any liability for damage resulting from the use of non-original parts or accessories.

Damage, deficiencies, misuse of safety installations

Machines which are not safe to operate must be immediately taken out of service and shall not be used, until these deficiencies have been properly rectified.

Safety installations and switches must neither be removed nor must they be made ineffective.

Notes on safety in the operating and maintenance instructions:

Danger

Paragraphs marked like this highlight possible dangers for persons.

Caution

Paragraphs marked like this highlight possible dangers for machines or parts of the machine.

Note

Paragraphs marked like this contain technical information for the optimal economical use of the machine.

Environment

Paragraphs marked like this point out practices for safe and environmental disposal of fuels and lubricants as well as replacement parts.

Observe environmental regulations.

Loading the machine

Use only safe lifting gear of sufficient load bearing capacity

Fasten the lifting gear only at the specified lifting points.

Check lifting eye for damage before use. Do not use a damaged or in any other way impaired lifting eye.

Secure the machine against tipping or slipping off.

Persons are highly endangered if

- the step under loads being lifted or
- stand under loads being lifted.
- The machine must not swing about when being lifted.

Secure the machine on the transport vehicle against rolling, slipping and turning over.

Starting the machine

Before starting

Become acquainted with the equipment, the control elements, the working principle of the machine and the working area.

Wear your personal protective outfit (hard hat, safety boots, etc.). Wear ear defenders.

Before starting the machine check whether:

- the machine shows any obvious faults
- all guards and safety elements are in place
- the controls are fully functional
- the machine is free of oily and combustible material
- all grips are free of grease, oils, fuel, dirt, snow and ice.

Use only machines which are serviced at regular intervals.

Do not use any starting aids like start pilot or ether.

Safety regulations

Starting and operation of the machine is closed rooms and trenches

Exhaust gases are highly dangerous! Always ensure an adequate supply of fresh air when starting and operating in closed rooms and trenches!

Operation

The machine must only be operated with the steering rod folded down.

Guide the machine in a way that hands do not knock against hard materials. Danger of injury.

Watch out for unusual noises and smoke when operating the plate. Investigate the cause and have the fault corrected.

The vibratory plate must only be operated at full engine speed, as otherwise the centrifugal clutch may be destroyed.

Never leave the plate unattended with the engine running..

Parking the machine

Park the machine on level, firm ground.

Before leaving the machine:

- park the machine so that it cannot turn over,
- Shut down the engine.

Mark machines, which could be in the way, with a clearly visible sign.

Filling in fuel

Do not inhale any fuel fumes.

Refuel only with the engine shut down.

Do not refuel in closed rooms.

No open fire, do not smoke.

Do not spill any fuel. Catch running out fuel, do not let it seep into the ground.

Keep dirt and water away from the fuel.

Maintenance work

Maintenance work must only be performed by qualified and authorized persons.

Keep unauthorized persons away from the machine.

Do not perform maintenance work while the motor is running.

Park the machine on level, firm ground.

Working on the engine

Drain the engine oil at operating temperature – danger of scalding!

Wipe off spilled oil, catch running out oil and dispose of environmentally.

Store used filters and other oil contaminated materials in a separate, specially marked container and dispose of environmentally.

Working on the fuel system

Avoid open fire, do not smoke, do not spill any fuel.

Catch running out fuel, do not let it seep into the ground and dispose off environmentally.

Cleaning work

Do not perform cleaning work while the motor is running.

Do not use gasoline or other easily inflammable substances for cleaning.

When using a steam cleaner for cleaning do not subject electrical parts and insulation material to the direct jet or cover these items beforehand.

Do not guide the water jet directly into air filter and air intake or exhaust muffler.

After maintenance work

After all maintenance work is completed reinstall all guards and safety installations.

Repair

Repair work must only be performed by qualified and authorized persons.

Exhaust gases are highly dangerous! Always ensure an adequate supply of fresh air when starting in closed rooms!

Mark defective machines by attaching a warning note to the steering handle.

Welding

Before starting welding work on the machine disconnect the battery and cover the fuel tank with insulating material.

Information and safety stickers/decals on the machine

Keep safety stickers in good and legible condition (see parts manual) and comply with their meaning.

Replace damaged and illegible stickers/decals.

Go to Discount-Equipment.com to order your parts

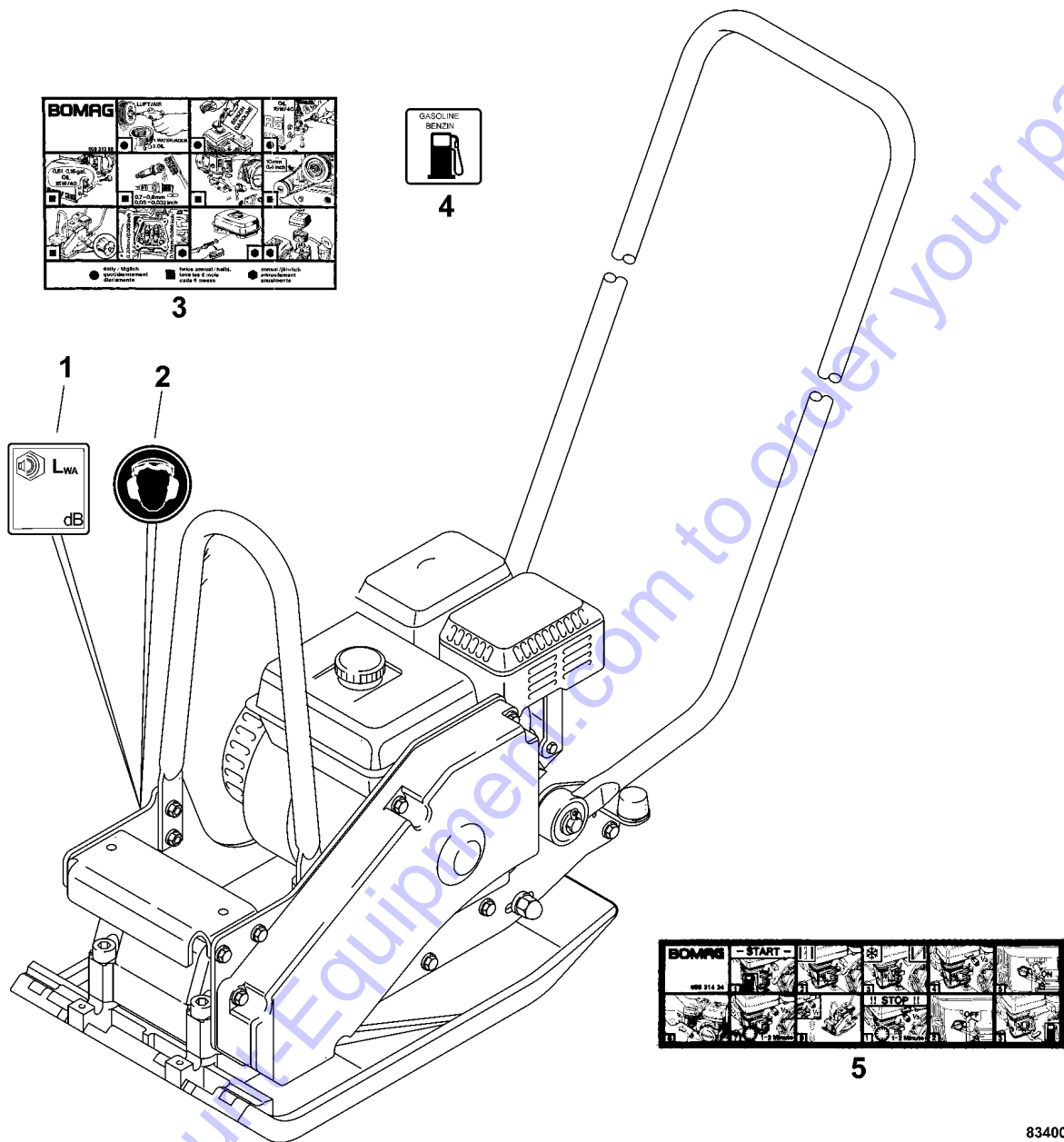

Fig. 5

Stickers and decals BVP 10/36, BVP 18/45

- 1 Information sticker "Guaranteed sound capacity level"
- 2 Instruction sticker "Wear ear defenders"
- 3 Maintenance sticker
- 4 Information sticker "Gasoline"
- 5 Brief operating instructions

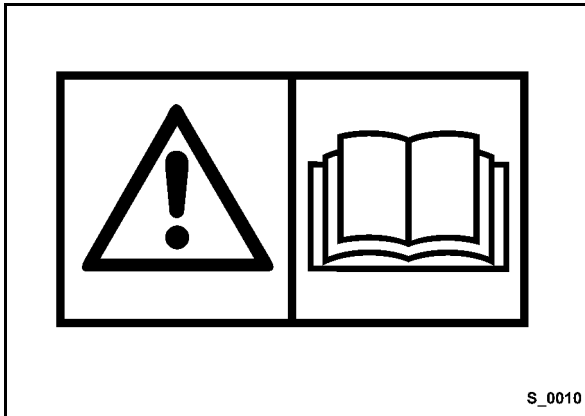

Fig. 6

Information sticker "Read operating instructions"



Fig. 7

Information sticker "Open choke and fuel valve"

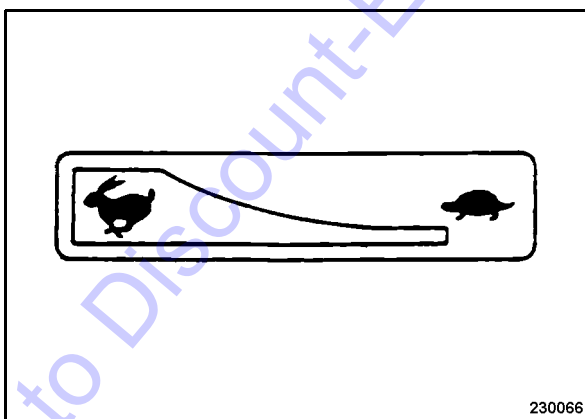

Fig. 8

Information sticker "Throttle lever"

Go to Discount-Equipment.com to order your parts

3 Indicators and Controls

Go to Discount-Equipment.com to order your parts

3.1 General notes

Please read this section thoroughly before operating this machine if you are not yet conversant with the indicators and control elements. All functions are described in detail hereunder.

Paragraph 4 Operation contains only concise descriptions of the individual operating steps.

3.2 Description of indicators and control elements

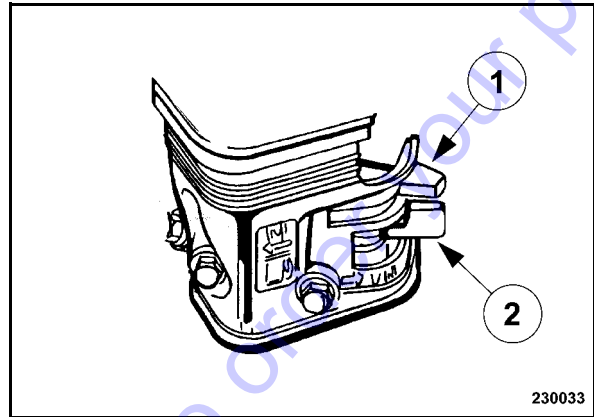

Fig. 9

No. 1 = Choke lever

Position "left" = Choke closed

Position "right" = Choke open

No. 2 = Fuel cock

Position "left" = Fuel tap closed.

Position "right" = Fuel tap open

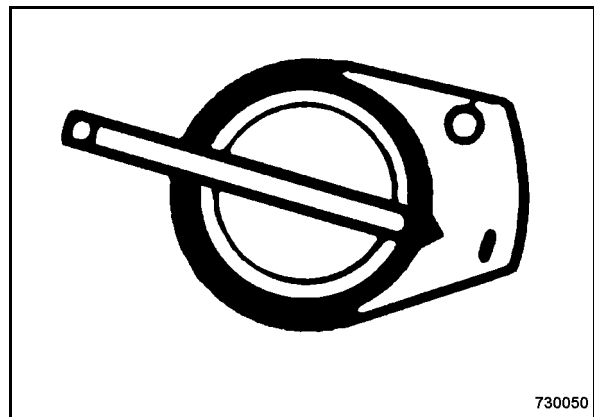

Fig. 10

No. 3 = Ignition switch

Position "0" = Ignition off

Position "I" = Ignition on

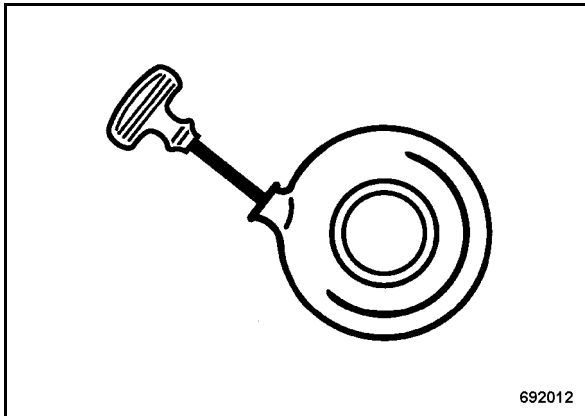

Fig. 11

No. 4 = Recoil starter

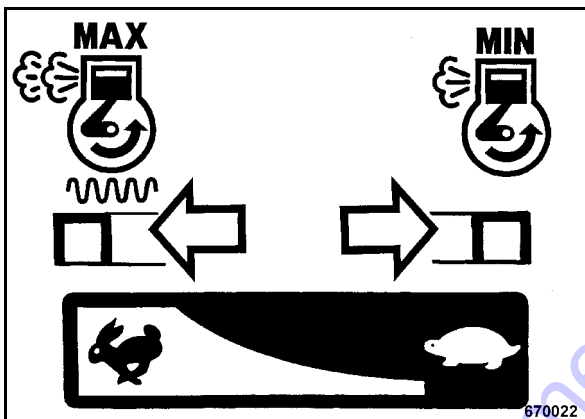

Fig. 12

No. 5 = Throttle lever

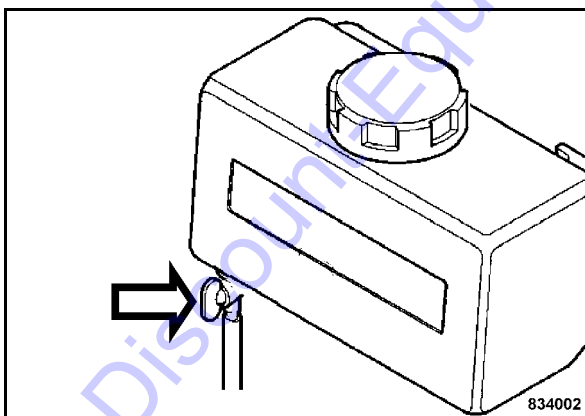

Fig. 13

No. 6 = Shut-off tap for water sprinkling system*

* Optional equipment

Go to Discount-Equipment.com to order your parts

4 Operation

Go to Discount-Equipment.com to order your parts

4.1 General

If you are not yet acquainted with the controls and indicating elements on this machine you should thoroughly read chapter 3 "Indicators and control elements" before starting work.

All indicators and control elements are described in detail in this chapter.

4.2 Tests before taking into operation

The following inspections must be carried out before each working day or before a longer working period.

⚠ Danger

Danger of accident!

Please observe strictly the safety regulations in chapter 2 of this instruction manual!

- Park the machine on ground as level as possible.
- Cleaning the machine.

Check:

- condition of engine and machine
- fuel tank and fuel lines for leaks
- screw joints for tight fit

i Note

For a description of the following tasks refer to the chapter "Daily maintenance".

- Engine oil level, top up if necessary
- Fuel level, top up if necessary.
- Fill the sprinkler system water tank*.

* Optional equipment

4.3 Mounting the steering bow

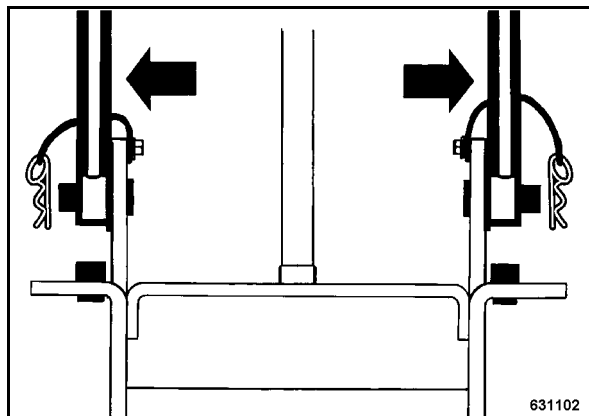

Fig. 14

- Force the steering bow (Fig. 14) apart and plug it onto the bracket.
- After attaching the steering bow secure on both sides with spring-type cotter pins.

4.4 Starting the engine

⚠ Danger

Exhaust gases are highly dangerous!

Always ensure an adequate supply of fresh air when starting and operating in closed rooms and trenches!

⚠ Danger

Danger of accident!

Before starting make sure that there are no persons in the danger area of engine or machine and that all safety installations are in place.

Always hold on to the machine. The machine moves immediately after starting.

Always keep an eye on a running machine.

⚠ Danger

Loss of hearing!

Wear your personal noise protection means (ear defenders) before starting operation.

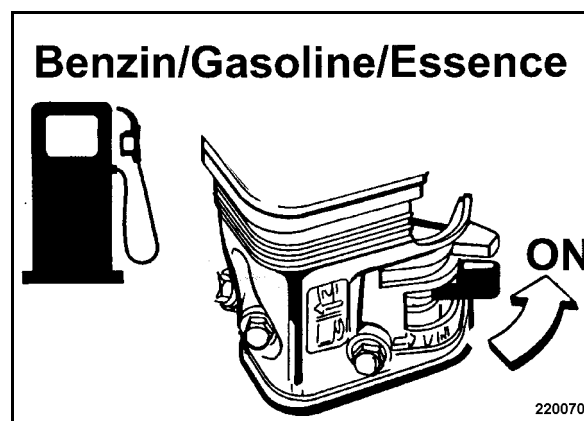

Fig. 15

- Open the fuel cock (Fig. 15) by turning in direction of arrow to the end stop.

Operation

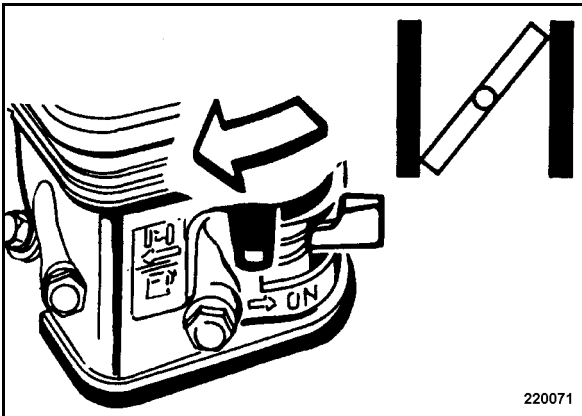

Fig. 16

- Close the choke completely by shifting the lever (Fig. 16) in direction of arrow against the end stop.

⚠ Caution

Do NOT operate the choke lever when the engine is warm or at high ambient temperatures.

⚠ Caution

The engine is equipped with low oil level safety shut-down. The engine cannot be started if the oil level is too low.

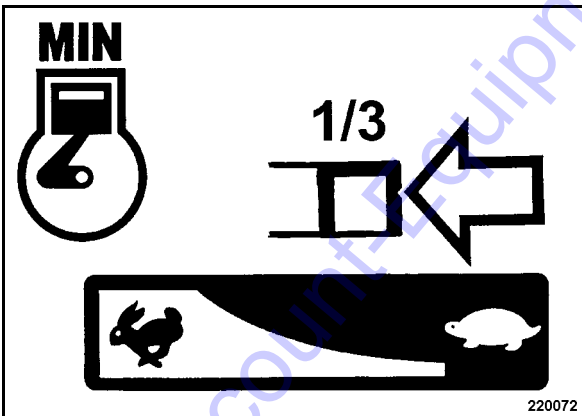

Fig. 17

- Set the throttle lever (Fig. 17) to 1/3 throttle position.

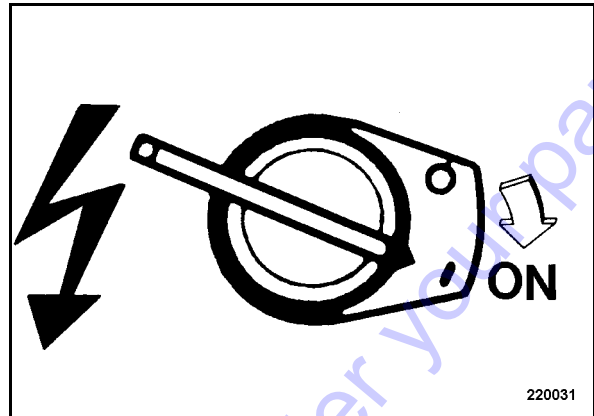

Fig. 18

- Turn the ignition switch (Fig. 18) to position "I" (ON).

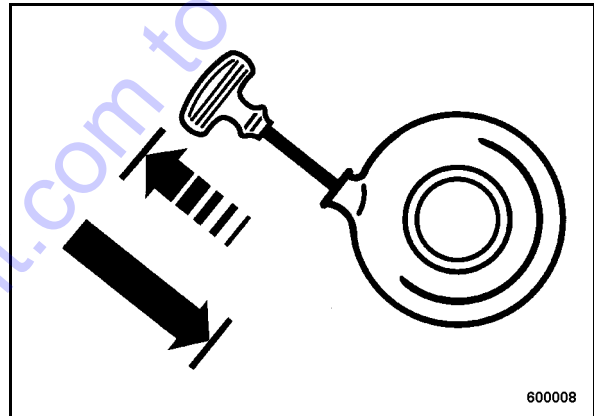

Fig. 19

- Slightly pull the starter handle (Fig. 19), until resistance can be felt (compression pressure), but do not pull out completely.
- Guide the starter rope back by hand.

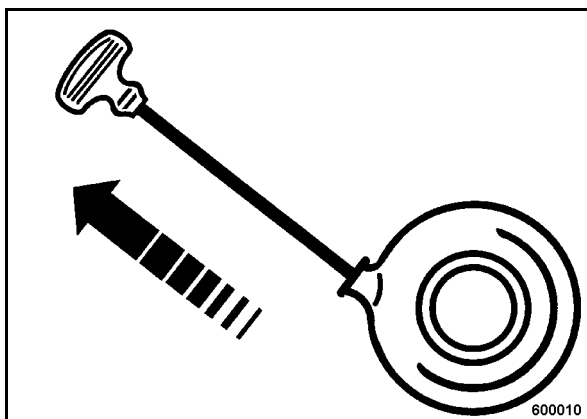

Fig. 20

- Pull the rope by the starter handle quickly and powerful as far out as possible (Fig. 20).

⚠ Caution

Do not let the starter handle hit back against the engine.

- If the engine does not start during the first attempt, repeat the starting process.

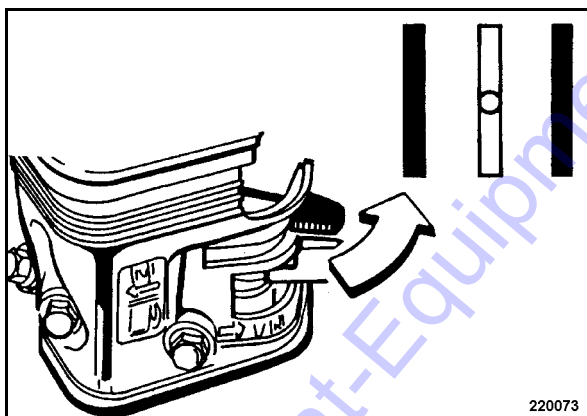

Fig. 21

- As the engine warms up open the lever (Fig. 21) of the choke bit by bit.

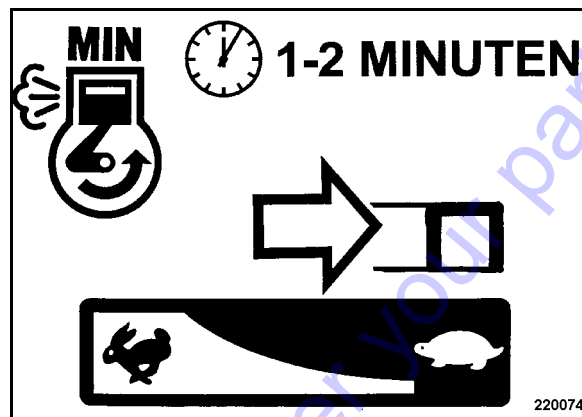

Fig. 22

- Move the throttle lever (Fig. 22) back to idle speed position.
- Run the engine warm for approx. 1 to 2 minutes in idle speed.

i Note

Operation of the vibratory plate can be started as soon as the engine responds to short throttle commands.

⚠ Caution

When the engine is running leave the ignition switch in position "I".

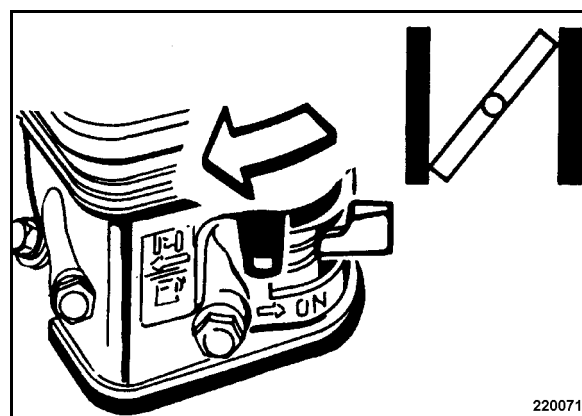

Fig. 23

- If the engine stops again after approx. 3 to 5 seconds, close the choke again with the lever (Fig. 23) and repeat the starting process.

Engine "drowned"

i Note

When the choke is closed and the starter rope is pulled several times, the engine draws in too much fuel and will probably not start.

Remedy

- Close the fuel cock.
- Open the choke.
- Set the throttle lever to full speed position.
- Operate the recoil starter until the engine starts.

i Note

If the engine does not start after 10 to 20 attempts

- Open the choke.
- Set the throttle lever to full speed position.
- pull off the spark plug socket.
- unscrew the spark plug.
- operate the starter several times.
- Dry the spark plug with a clean cloth or blow it dry with compressed air. If necessary clean with a wire brush.
- Screw the spark plug back in and plug the spark plug socket back on.
- Repeat the starting procedure.

4.5 Work/operation

⚠ Danger

Danger of accident!

Steer the vibratory plate only by the steering handle.

⚠ Caution

Operate the vibratory plate only with full engine speed, as otherwise the centrifugal clutch will be destroyed.

For short breaks you should always return the throttle lever to idle speed position, this avoids premature wear of the centrifugal clutch.

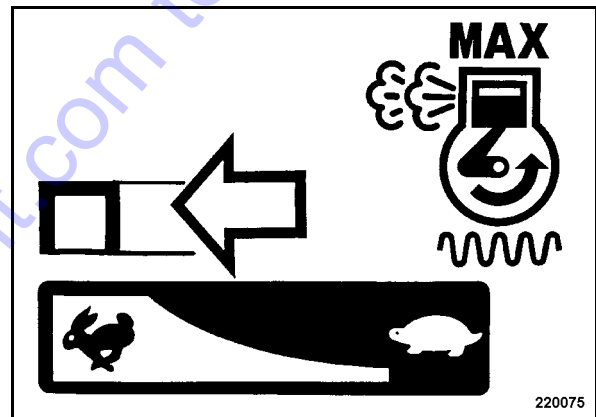

Fig. 24

- Shift the throttle lever (Fig. 24) in direction of arrow to full load position.

The vibratory plate works with highest frequency.

4.6 Switching on the water sprinkling system*

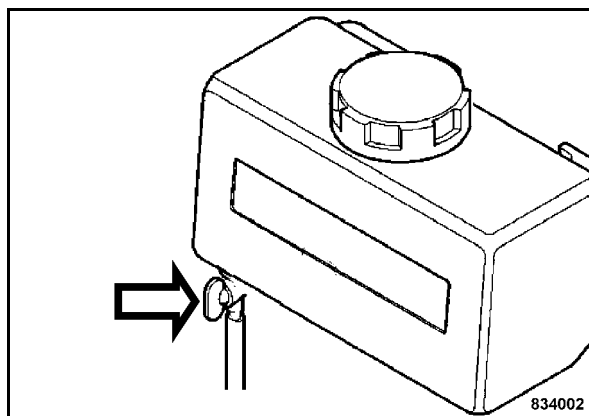

Fig. 25

- Set the handle of the shut-off valve (Fig. 25) in flow direction.

4.7 Switching the motor off

⚠ Caution

Do not shut the engine down all of the sudden from full speed, but let it idle for a while for temperature equalization.

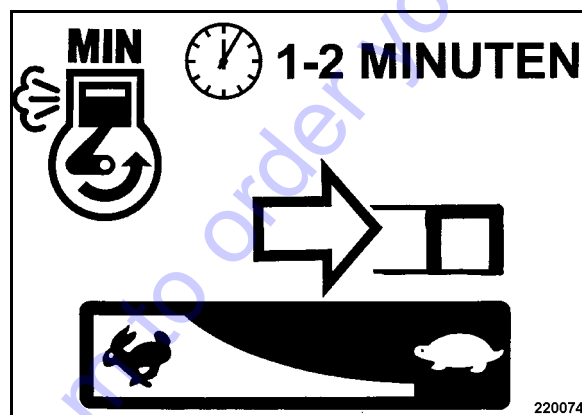

Fig. 26

- Move the throttle lever (Fig. 26) back to idle speed position.

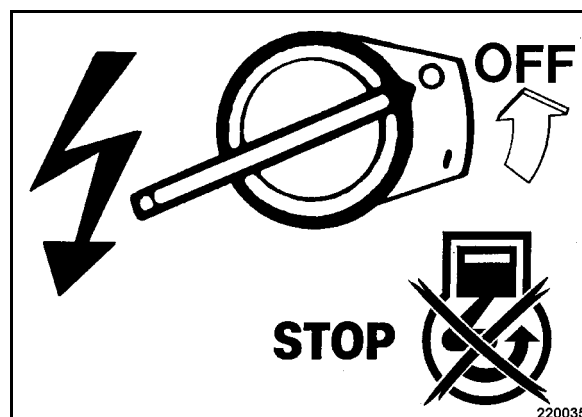

Fig. 27

- Turn the ignition switch to position OFF (Fig. 27), the engine will stop.

* Optional equipment

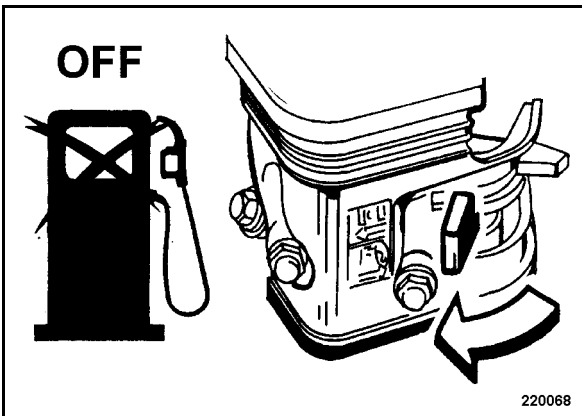

Fig. 28

- Close the fuel tap (Fig. 28) by turning in direction of arrow.

4.8 Loading/transport

⚠ Danger

Danger of accident!

Make sure that persons are not endangered by the machine tipping or sliding off.

Lash the machine down, so that it is secured against rolling, sliding and turning over.

For lifting the machine attach the lifting gear only to the lifting point (cross strut on the engine protection bow).

Check lifting eye for damage before use. Do not use a damaged or in any other way impaired lifting eye.

The machine must not swing about when being lifted.

Do not step or stand under suspended loads.

Use only safe lifting gear of sufficient load bearing capacity Minimum lifting capacity of lifting gear: see operating weight in chapter "Technical Data".

Tie the machine down on the transport vehicle, so that it is secured against slipping, sliding and turning over!

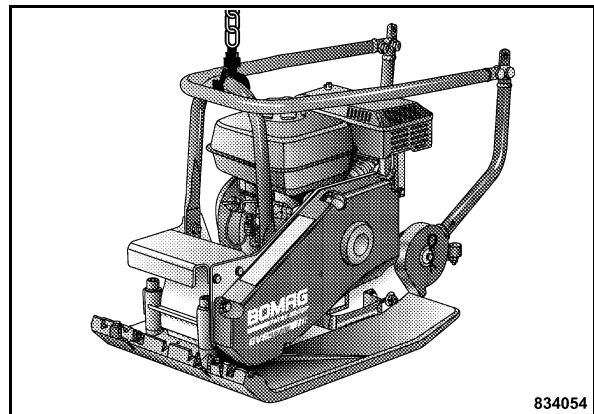

Fig. 29

- Always attach the lifting gear (rope) to the motor protection frame to load the vibratory plate on a transport vehicle (Fig. 29).

5 Maintenance

Go to Discount-Equipment.com to order your parts

5.1 General notes on maintenance

When performing maintenance work ensure strict compliance with the respective safety instructions and particularly the safety regulations mentioned in chapter 2 of these operating and maintenance instructions.

Thorough maintenance of the machine guarantees far longer safe functioning of the machine and prolongs the lifetime of important components. The effort needed for this work is only little compared with the problems that may arise when not observing this rule.

- Always clean machine and engine thoroughly before starting maintenance work.
- For maintenance work stand the machine on level ground.
- Perform maintenance work only with the engine shut down.

Environment

During maintenance work catch all oils and fuels and do not let them seep into the ground or into the sewage system. Dispose of oils and fuels environmentally.

Notes on the fuel system

The lifetime of the engine mainly depends on the purity of the fuel.

- Keep fuel clean of any contamination and water.
- Keep used filters in a separate waste container and dispose of environmentally.
- When choosing the storage place for fuel make sure that spilled fuel will not harm the environment.

Notes on the performance of the engine

On engines both combustion air and fuel injection quantities are thoroughly adapted to each other and determine power, temperature level and exhaust gas quality of the engine.

If your engine has to work permanently in "thin air" (at higher altitudes) and under full load, you should

consult the customer service of BOMAG or the customer service of the engine manufacturer.

Frequent causes of faults

- Operating errors
- Incorrect, inadequate maintenance

If you cannot locate the cause of a fault or rectify it yourself by following the trouble shooting chart, you should contact the service departments at our branch offices or dealers.

5.2 Fuels and lubricants

Engine oil

Use winter grade engine oil for winter operation!

In order to assure perfect cold starting it is important to choose the viscosity (SAE-class) of the engine oil according to the ambient temperature.

For winter operation below $-10\text{ }^{\circ}\text{C}$ the oil change intervals must be shortened.

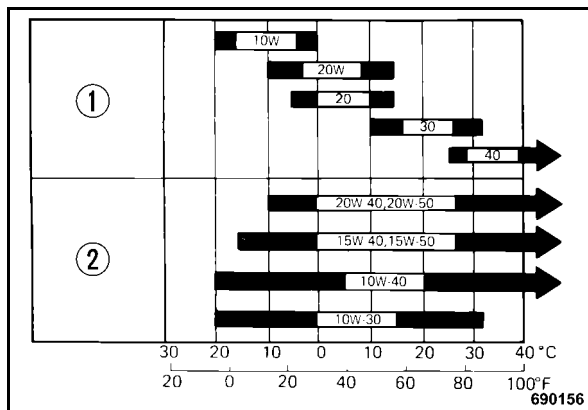

Fig. 30

Lubrication oil with a too high viscosity index causes starting difficulties, the temperature when starting the engine is therefore of highest importance when choosing the viscosity of engine oil for winter operation.

Oil viscosity

Since lubrication oil changes its viscosity with the temperature, the ambient temperature at the operating location of the engine is of utmost importance when choosing the viscosity class (SAE-class) (see diagram).

SAE10W-30 is recommended for general use under any temperature. When using single purpose oil you must choose the correct viscosity for the area of use.

Occasional falling short of the temperature limit (e.g. use of SAE 15W/40 down to $-15\text{ }^{\circ}\text{C}$) may affect the cold starting ability of the engine, but will not cause any engine damage.

Temperature related lubrication oil changes can be avoided by using multi-purpose oils. The following oil change intervals apply also when using multi-purpose oils.

Oil quality

You should preferably use oils of API-quality class SF or SG, SHPD oils or CCMC-D4-D5-PD2 oils.

The API-classification is used to classify the oil quality.

The oil manufacturer is solely responsible for assigning a product to a certain quality class.

i Note

When changing to a higher alloyed oil quality after a longer period of operation, it is recommended to perform the first oil change of the higher quality oil already after 25 operating hours.

Oil change intervals

The longest permissible time the lubrication oil should remain in an engine is 1/2 year or 100 operating hours.

Fuel

Quality

Use automobile gasoline (preferably unleaded fuel or fuel with a low lead content, in order to reduce the combustion residues to a minimum).

Do not use oil-gasoline mixes or contaminated gasoline. Protect the fuel tank against dirt, dust or water.

Alcohol containing gasoline

If you decide on using alcohol containing gasoline (Gasohol), you should make sure that the octane number is at least as high as for unleaded gasoline.

There are two types of "Gasohol" available: one contains ethanol and the other one methanol. Do not use "Gasohol" with more than 10% ethanol. Do not use any gasoline with admixed methanol (methyl or methyl alcohol), which does not contain solvents or corrosion protection for methanol. Do not use gasoline with more than 5% methanol, even if it contains solvents and corrosion protection agents.

5.3 Table of fuels and lubricants

Assembly	Fuel or lubricant		Quantity approx.
	Summer	Winter	Attention Observe the level marks
Engine			
- Engine oil	Engine oil API SF or SG SAE 10W/30 (-20 °C to +30 °C) SAE 10W/40 (-20 °C to +40 °C) SAE 10W/40 (-15 °C to +40 °C)		0,6 l to oil level mark
	SAE 30 (+10 °C to +30 °C)	SAE 10 W (-20 °C to 0 °C)	
	SAE 40 (+25 °C to +45 °C)	SAE 20W/20 (-10 °C to +10 °C)	
- Fuel	Gasoline (unleaded)		BVP 10/36: 2.5 l BVP 18/45: 3.6 l
Water tank	Water	Water with anti-freeze agent	7 l
Vibrator shaft housing	as engine oil		0.25 l

Go to Discount-Equipment.com to order your parts

5.4 Running-in instructions

The following maintenance work must be performed when running in new machines or overhauled engines:

⚠ Caution

During the running-in period, up to approx. 200 operating hours, check the engine oil level twice every day.

Depending on the load the engine is subjected to, the oil consumption will drop to the normal level after approx. 100 to 200 operating hours.

After 25 operating hours

- Change the engine oil.
- Check engine and machine for leaks.
- Check the valve clearance, adjust if necessary
- Retighten the fastening screws on air filter exhaust, fuel tank and other attachments.
- Retighten the bolted connections on the machine.
- Check the vibration drive V-belts.
- Check the oil level in the vibrator housing.

5.5 Maintenance table

With all maintenance intervals perform also the work for shorter preceding service intervals.

No.	Maintenance work	Comment	daily	weekly	monthly	half-annually	annually	as required
5.6	Clean the machine		X					
5.7	Checking the engine oil level	Dipstick mark	X					
5.8	Check the fuel level		X					
5.9	Fill the water tank		X					
5.10	Clean the air filter	in case of extreme dust clean every day		X				
5.11	Clean the cooling fins and the cooling air intake openings				X			
5.12	Change the engine oil	at least every 250 operating hours				X		
5.13	Clean, check the spark plug					X		
5.14	Clean the slurry filter					X		
5.15	Check the oil level in the exciter housing					X		
5.16	Check, tension the V-belt, replace if necessary					X		
5.17	Check, adjust the valve clearance						X	
5.18	Clean the fuel screen						X	
5.19	Change the oil in the exciter housing	at least every 500 operating hours					X	
5.20	Check the rubber buffers						X	
5.21	Change the air filter	at least every year						X
5.22	Flush the water sprinkler system							X
5.23	Tighten all bolted connections							X
5.24	Engine conservation							X

5.6 Cleaning the machine

Caution

Perform cleaning work only after the engine has cooled down and with the engine stopped.

Dirty operating conditions, particularly lubrication oil and fuel deposits on the cooling fins of the engine and the cooling air intake opening have an adverse effect on the cooling of the engine.

You should therefore immediately seal any oil or fuel leaks near fuel tank, cylinder or cooling air intake.

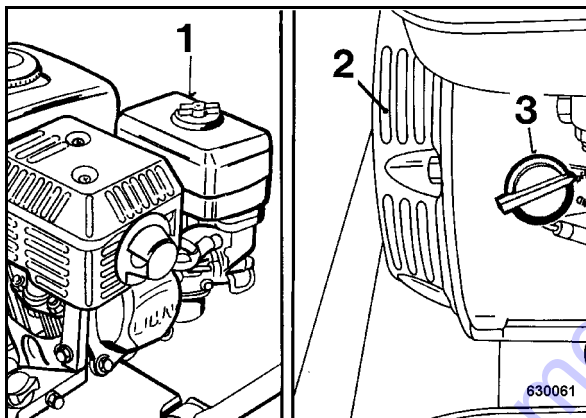

Fig. 31

Caution

Do not guide the water jet directly into air filter/ carburettor (1) (Fig. 31), starter/air intake (2) and the ignition switch (3).

- After wet cleaning run the engine warm to evaporate all water residues and to avoid corrosion.

5.7 Check the engine oil level

Caution

Park the machine on level ground so that the engine is in horizontal position.

For quality and quantity of oil refer to the "table of fuels and lubricants".

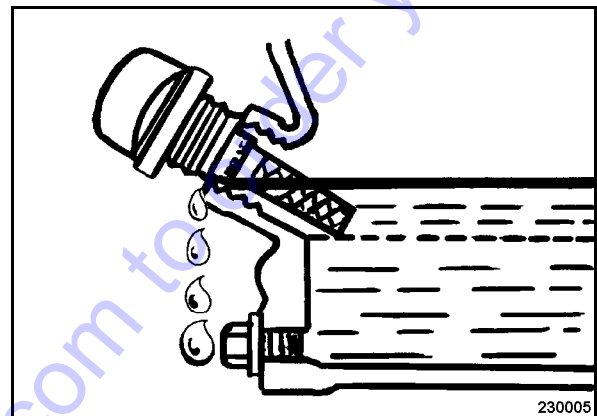

Fig. 32

- Shut down the engine.
- Pull out the dipstick (Fig. 32) and wipe it clean with a lint-free, clean cloth.
- Insert the dipstick into the oil filler socket, do not screw it in, but pull it out again to check the oil level.
- If the oil level is near or below the bottom limit mark on the dipstick, fill in recommended oil up to the top dipstick mark (bottom edge of oil filler neck). Do not overfill.

5.8 Check the fuel level

⚠ Danger

Fire hazard!

When working on the fuel system do not use open fire, do not smoke, do not spill any fuel.

Do not refuel in closed rooms.

Shut down the engine.

⚠ Danger

Health hazard!

Do not inhale any fuel fumes.

⚠ Caution

Contaminated fuel can cause malfunction or even damage of the engine.

For quality and quantity of oil refer to the "table of fuels and lubricants".

🌿 Environment

Catch running out fuel, do not let it seep into the ground.

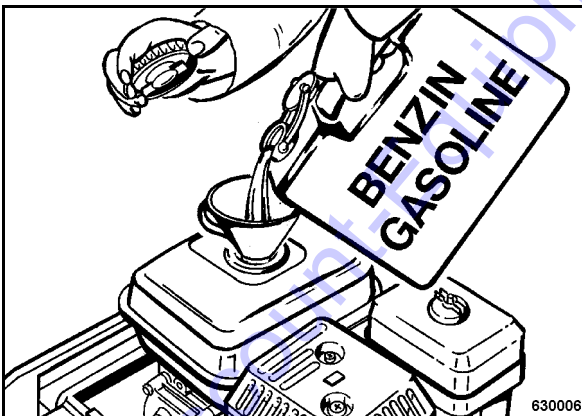

Fig. 33

- Clean the area around the filler cover, unscrew the filler cover (Fig. 33).
- Fill in fuel through a funnel with screen.
- Close the tank again.

5.9 Filling the water tank*

⚠ Caution

Dirty or contaminated water can block the nozzles!

Fill only with clean water.

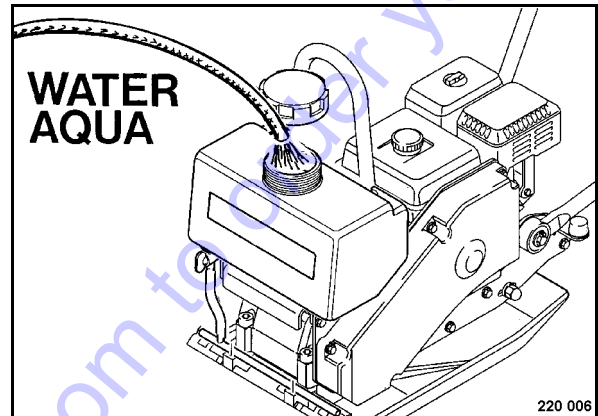

Fig. 34

- Open the water tank (Fig. 34) and fill in clean water.

* Optional equipment

5.10 Cleaning the air filter

⚠ Danger

Do not use gasoline or cleansers with a low flash-point to clean the air filter element. This could cause fire or an explosion.

⚠ Caution

Do not run the engine without an air filter, since this could cause premature wear of the engine.

Contaminants or dirt must not enter into the intake channel.

Contamination of the air filter depends mainly on the proportion of dust in the intake air, if necessary clean several times a day.

Air filters with damaged filter element or seal ring must be replaced in any case. It is therefore recommended to keep at least one air filter in stock.

The air filter must be changed after several times cleaning, but at the latest after 1 year.

Each cleaning interval must be marked with a cross on the cover of the air filter.

Cleaning does not make sense if the air filter is covered with a sooty deposit. Use a new air filter.

Incorrectly handled air filters may become ineffective because of damage (e.g. cracks) and cause damage to the engine.

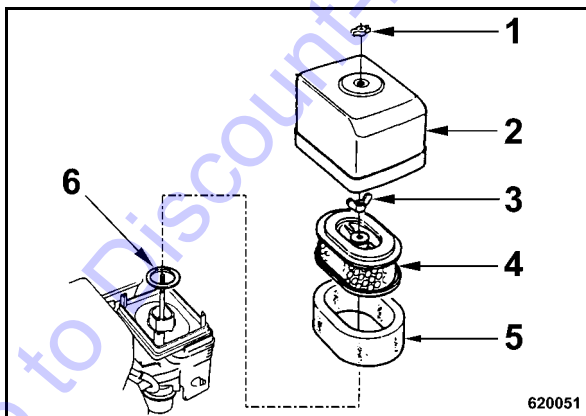

Fig. 35

- Unscrew wing nut (1) (Fig. 35) and remove the housing cover (2).

- Clean the housing cover from inside.
- Unscrew wing nut (3) and take off paper element (4) with the foam rubber insert (5).
- Check the rubber seal (6), replace if necessary.

⚠ Caution

The rubber seal (6) frequently sticks to the paper element.

Visual inspection/cleaning

- Examine the filter thoroughly for perforations and cracks and replace if damaged.

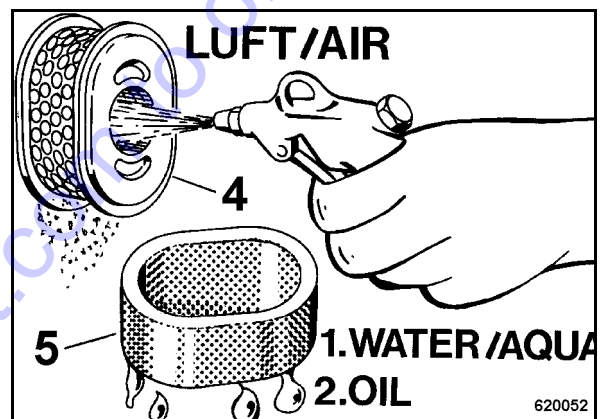

Fig. 36

- Clean the paper insert (4) (Fig. 36) carefully by light banging or blow it carefully out from inside to outside with dry, clean compressed air (max. 2 bar).
- In case of excessive dirt replace the paper element.
- Clean the foam insert (5) in warm soapy water, rinse it and let it dry thoroughly.
- Soak the foam insert in clean engine oil. Then squeeze out excess oil.

Go to Discount-Equipment.com to order your parts

5.11 Clean the cooling fins and the cooling air intake openings

⚠ Caution

Dirty operating conditions, particularly lubrication oil and fuel deposits on the cooling fins of the engine and the cooling air intake opening have an adverse effect on the cooling of the engine.

You should therefore immediately seal any oil or fuel leaks near fuel tank, cylinder or cooling air intake.

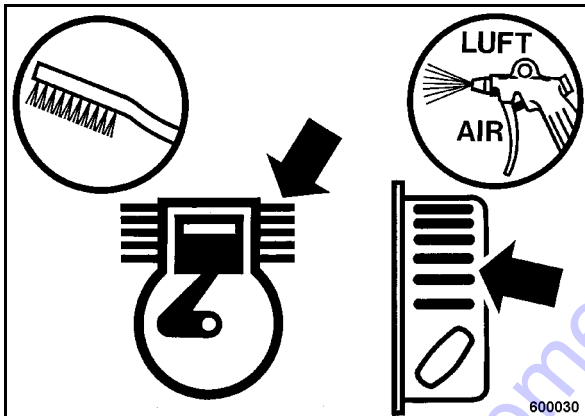

Fig. 37

- Loosen dried on dirt with a suitable brush (Fig. 37) from all cooling fins and cooling air intake openings and blow it off with compressed air.

⚠ Danger

Fire hazard!

Do not use any inflammable solvents.

⚠ Caution

Do not guide the water jet directly into the cooling air openings of the recoil starter, into the dry air filter and on electrical equipment.

- On a oil contaminated engine use a cold cleansing agent for cleaning.

- After a sufficient soaking time clean off with a water or steam jet and blow out with compressed air.
- Run the engine warm for a while to avoid corrosion.

⚠ Caution

Look for the cause of oily contamination and have any leaks sealed by the customer service of BOMAG.

Go to Discount-Equipment.com to order your parts

5.12 Change the engine oil

⚠ Danger

Danger of scalding!

When draining off hot oil.

⚠ Caution

Drain the engine oil only when the engine is warm.

For quality and quantity of oil refer to the "table of fuels and lubricants".

♻ Environment

Catch running out old oil, do not let it seep into the ground and dispose off environmentally.

i Note

Tilt the machine towards the guide handle.

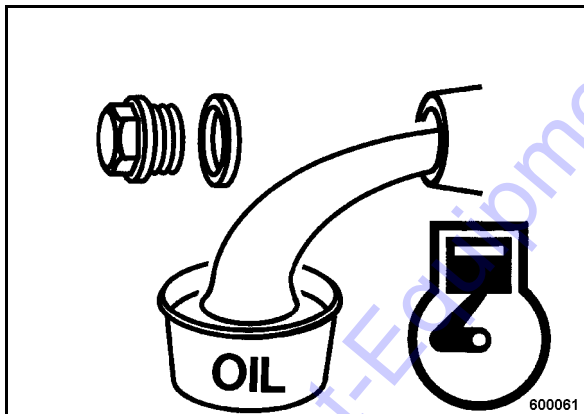

Fig. 38

- Unscrew the oil drain plug (Fig. 38), let the old oil run out and catch it.
- Turn the oil drain plug back in with a new seal ring.

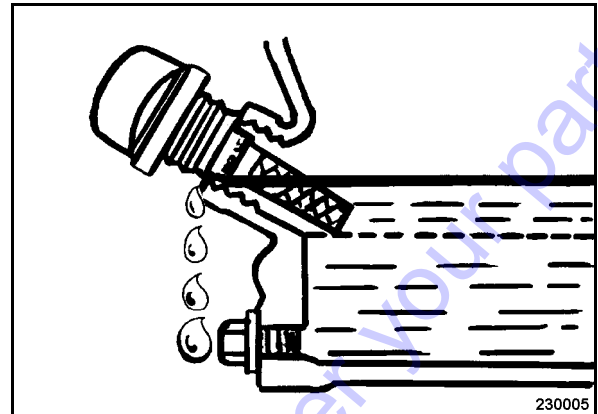

Fig. 39

- Position the engine horizontally and unscrew the oil dipstick (Fig. 39).
- Fill in oil through the oil filler opening, until it reached the filler socket.
- Check the seal on the dipstick, replace if necessary.
- Screw the oil dipstick back in.

5.13 Checking, cleaning the spark plug

⚠ Danger

Danger of burning on hot engine!

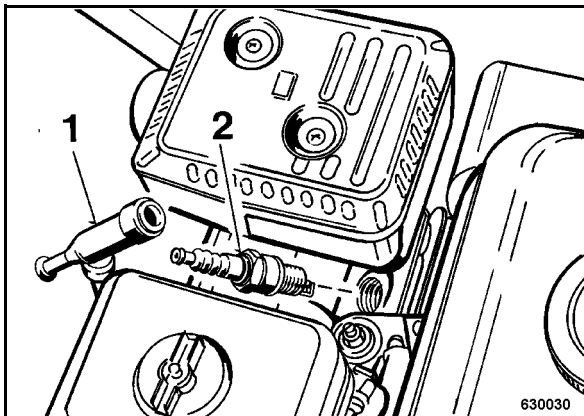

Fig. 40

- Pull off the spark plug socket (1) (Fig. 40) and unscrew the spark plug (2).

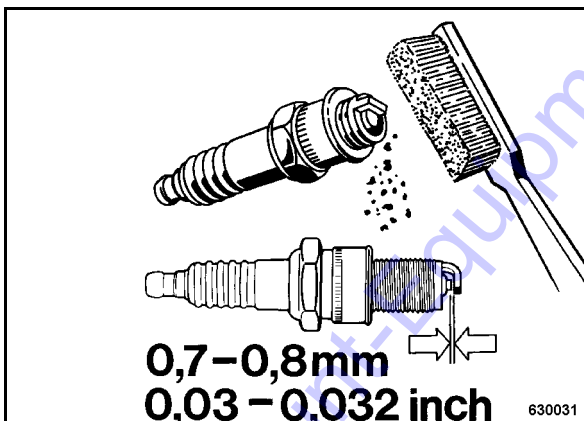

Fig. 41

- Check the spark plug visually and clean it if necessary (Fig. 41).

i Note

In case of excessive combustion residues, burned off electrodes or torn insulator replace the spark plug.

⚠ Caution

Make sure to use a spark plug with correct heat value.

- Check the electrode gap with a feeler gauge, if necessary adjust the gap to 0,7 to 0,8 mm.
- Screw the spark plug in by hand and tighten it until it bottoms.

i Note

A new spark plug needs to be tightened by another 1/2 turn after contact, so that the seal is compressed. If an old spark plug is to be used again, tighten it for another 1/8 - 1/4 turn after contact, in order to compress the seal ring.

- Tighten the spark plug.

⚠ Caution

The spark plug must be correctly tightened. An incorrectly tightened spark plug can get very hot and cause engine damage.

5.14 Cleaning the fuel sludge filter

⚠ Danger

Gasoline is easily inflammable, do not spill any gasoline.

Do not smoke, no open fire.

Do not inhale any fuel fumes.

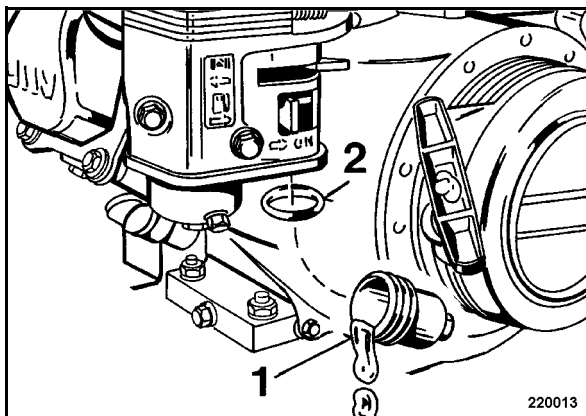

Fig. 42

- Unscrew the fuel sludge filter 1 (Fig. 42) with the fuel cock closed and wash it out with fuel.
- Turn the fuel sludge filter in tightly and mind the O-ring (2).

5.15 Checking the oil level in the vibrator housing

i Note

Park the machine on level ground.

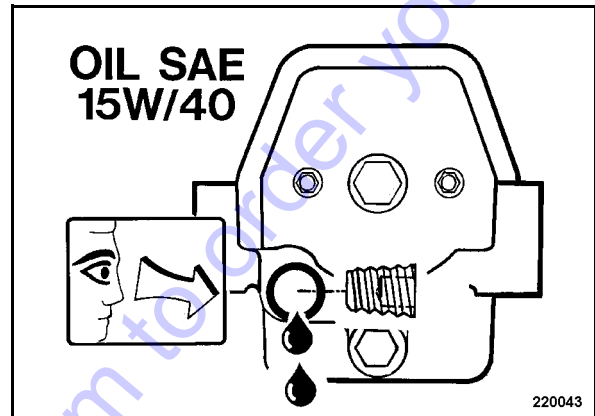

Fig. 43

- Unscrew the screw (Fig. 43) and check the oil level.

The oil level must reach the lower edge of the bore, top up oil if necessary.

For quality and quantity of oil refer to the table of fuels, lubricants and filling capacities.

- Screw the drain plug tightly back in.

5.16 Checking the V-belt, tightening, replacing if necessary

Checking the V-belt

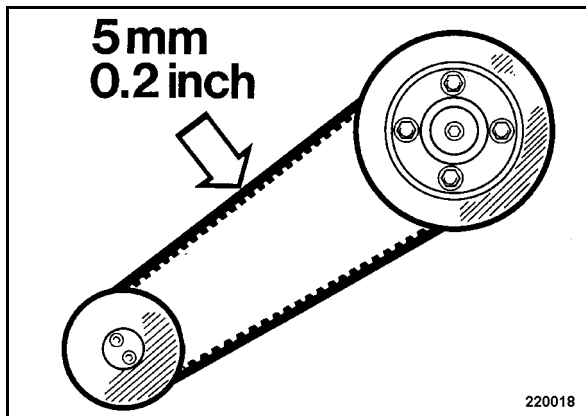

Fig. 44

- Remove the V-belt guard.
- Check the condition and tension of the V-belt, replace the V-belt if damaged.
- Compression measurement approx. 5 mm (Fig. 44).

Changing the V-belt

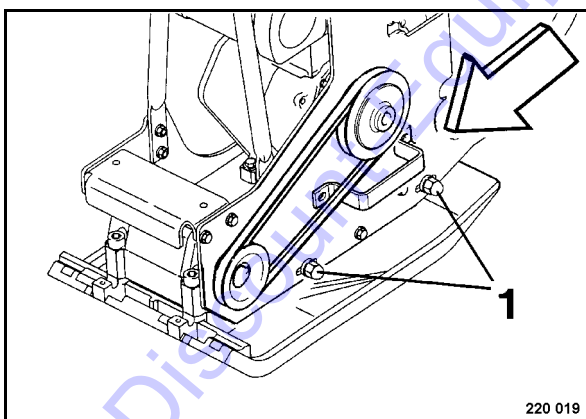

Fig. 45

- Slightly loosen two fastening screws (1) (Fig. 45) on both sides of the engine carrier.
- Push the motor carrier forward and take the V-belt off.
- Install the new V-belt.

Tightening the V-belt

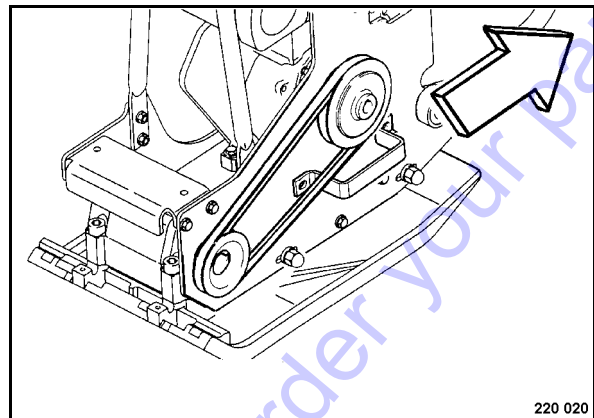

Fig. 46

- Pull the engine carrier back (Fig. 46) until the correct V-belt tension is achieved and tighten the four fastening screws.
- Assemble the V-belt guard.

Caution

Check the V-belt tension again after a running time of approx. 25 operating hours, retighten if necessary.

5.17 Checking, adjusting the valve clearance

i Note

Check and adjust only when the engine is cold.

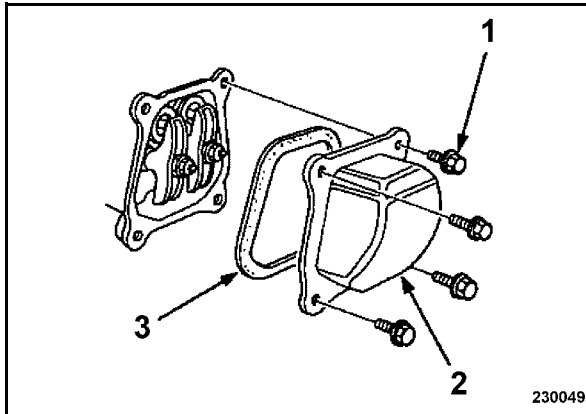

Fig. 47

- Loosen the screws (1) and take off the valve cover (2) (Fig. 47) with gasket (3).

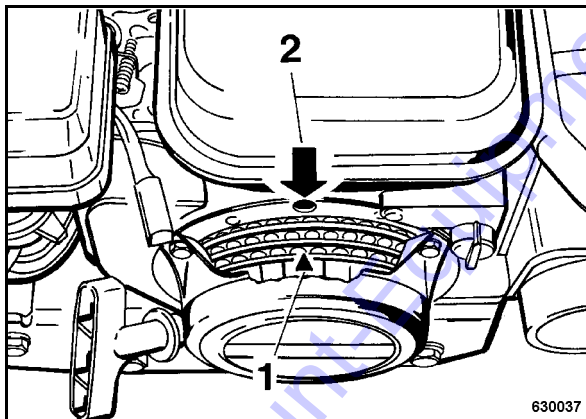

Fig. 48

- Set the piston to top dead centre position of the compression stroke.
- For this purpose align triangle mark (1) (Fig. 48) on the starter disc to the top bore (2).

Check the valve clearance

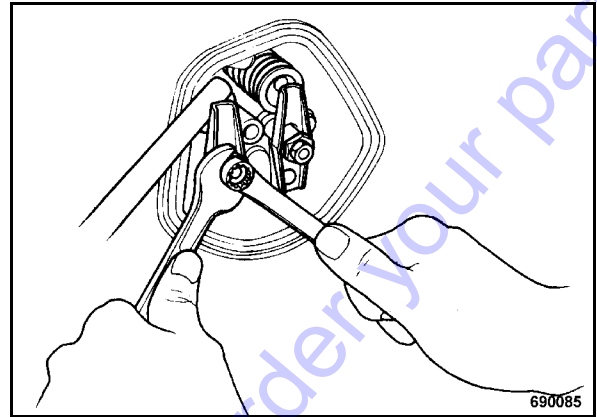

Fig. 49

- Check the valve clearance with a feeler gauge on both valves (1) (Fig. 49).

i Note

Exhaust valve clearance: 0.20 mm

Intake valve clearance: 0.15 mm

Adjust the valve clearance

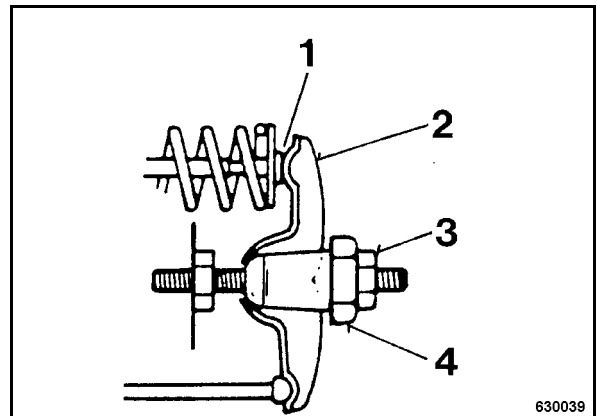

Fig. 50

- Hold hexagon nut (4) (Fig. 50) on the rocker lever and loosen counter nut (3).
- Adjust hexagon nut (4) on the rocker arm so that the feeler gauge fits between rocker arm and valve shaft (1) with noticeable resistance after retightening counter nut (3).
- Install the valve cover with a new gasket and tighten the screws evenly.

5.18 Cleaning the fuel screen

⚠ Danger

Fire hazard!

When working on the fuel system do not use open fire, do not smoke and do not spill any fuel.

Clean the fuel screen filter only when the engine is cold.

⚠ Danger

Health hazard!

Do not inhale any fuel fumes.

♻ Environment

Catch running out fuel and dispose of environmentally.

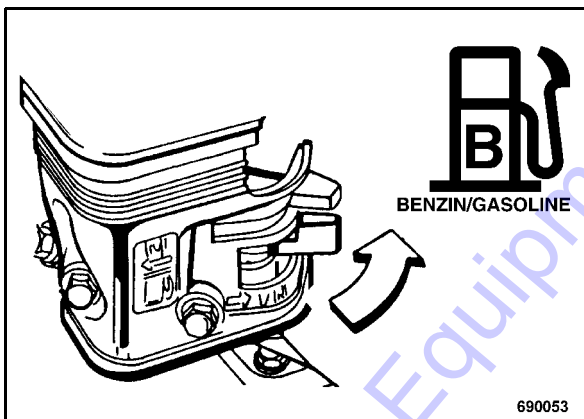

Fig. 51

- Open the fuel tap (Fig. 51) by turning in direction of arrow.

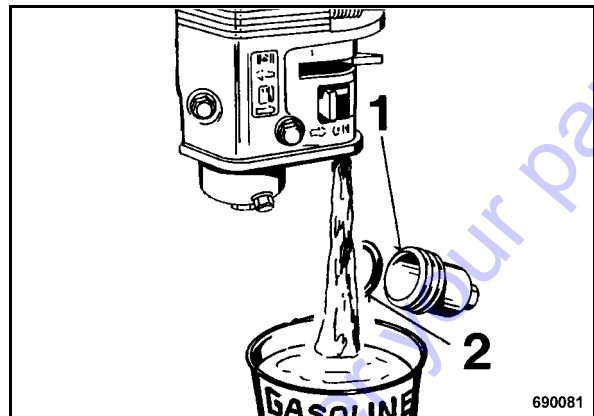

Fig. 52

- Unscrew the fuel sludge filter 1 (Fig. 52) and drain off all gasoline.
- Check seal ring (2) for cracks, replace the seal if damaged.
- Screw the fuel sludge filter with sealing ring (2) in tightly.

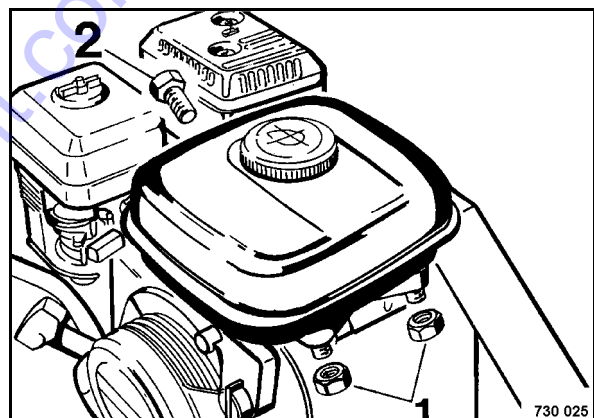

Fig. 53

- Disassemble the fuel tank, for this purpose unscrew hexagon nuts (1) (Fig. 53) and hexagon screw (2).

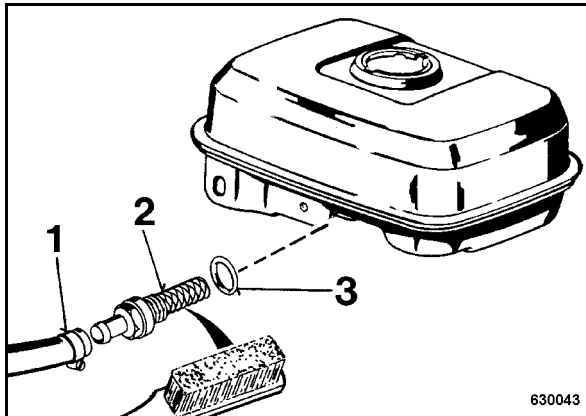

Fig. 54

- Open the hose clamp (1) (Fig. 54), pull off the hose.
- Unscrew fuel screen (2).
- Clean the fuel screen, check the condition of the screen (holes), replace if necessary.
- Check the seal (3) for damage, change if necessary.
- Turn the fuel screen filter tightly in with the seal.
- Reassemble the fuel tank.

5.19 Changing the oil in the vibrator housing

- Tilt the machine slightly towards the side with the oil drain plug and support it safely.

Environment

Environmental hazard!

Catch all old oil, do not let it seep into the ground but dispose of environmentally.

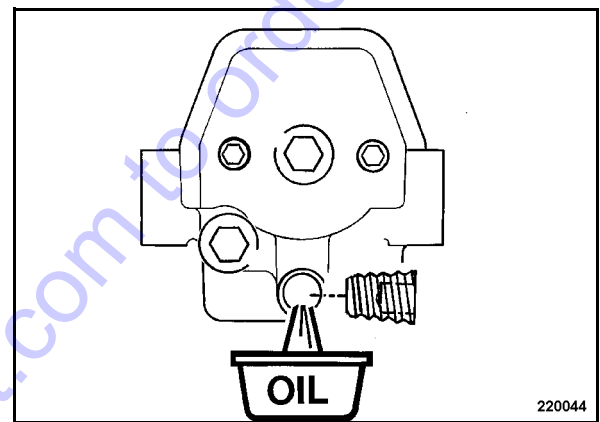

Fig. 55

- Unscrew the drain plug (Fig. 55) and catch the old oil.
- Screw the drain plug tightly back in.
- Stand the machine horizontally.

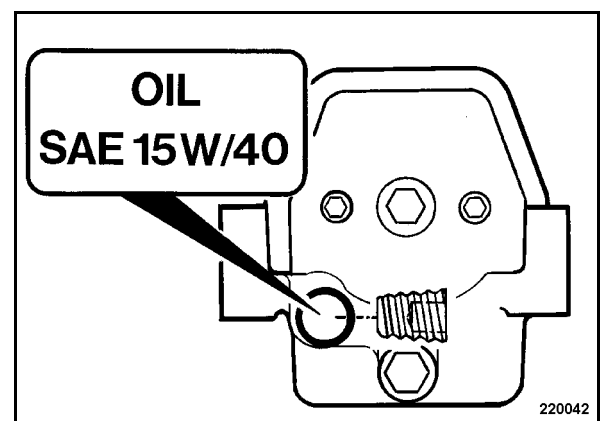

Fig. 56

- Unscrew the plug (Fig. 56) and fill with engine oil.

Maintenance every year

For quality and quantity of oil refer to the table of fuels, lubricants and filling capacities.

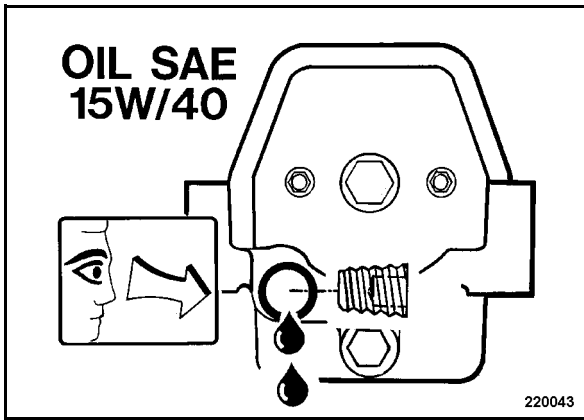

Fig. 57

i Note

The oil level must reach the lower edge of the bore (Fig. 57).

- Screw the plugs back in (Fig. 56).

5.20 Check the rubber buffers

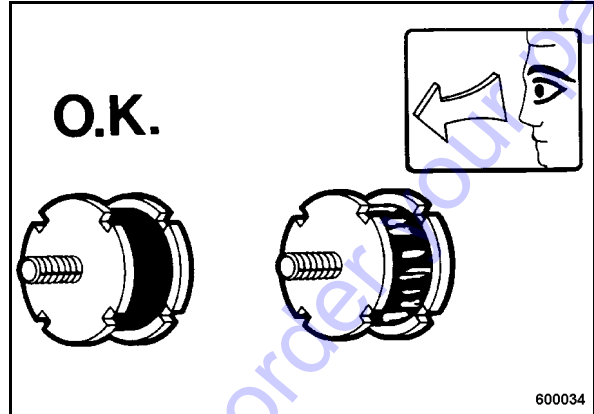

Fig. 58

- Check all rubber buffers (Fig. 58) for tight fit, cracks and damage and replace immediately if damaged.

5.21 Change the air filter

Caution

Do not run the engine without an air filter, since this could cause premature wear of the engine.

The air filter must be changed after several times cleaning, but at the latest after 1 year.

Contaminants or dirt must not enter into the intake channel.

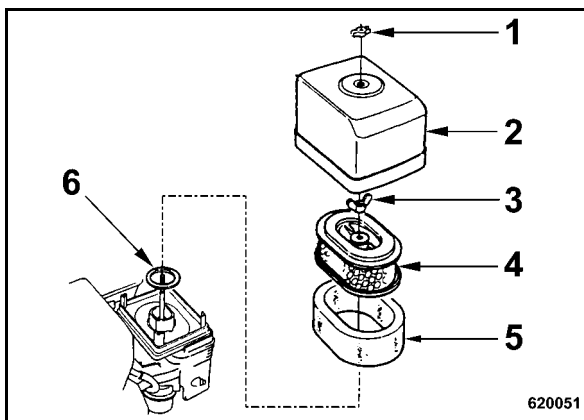

Fig. 59

- Unscrew wing nut (1) (Fig. 59) and remove the housing cover (2).
- Clean the housing cover from inside.
- Unscrew wing nut (3) and take off paper element (4) with the foam rubber insert (5).
- Check the rubber seal (6), replace if necessary.

Caution

The rubber seal (6) frequently sticks to the paper element.

- Soak the new foam rubber insert (5) in clean engine oil. Then squeeze out excess oil.
- Pull the foam rubber element (5) over the new paper element (4).
- Insert the air filter correctly and tighten it with the wing nut (3).

Caution

If the air filter is not correctly inserted, dust and foreign particles can enter into the air intake channel.

- Reassemble the housing cover (2) with the wing nut (1).

5.22 Flushing the water sprinkler system*

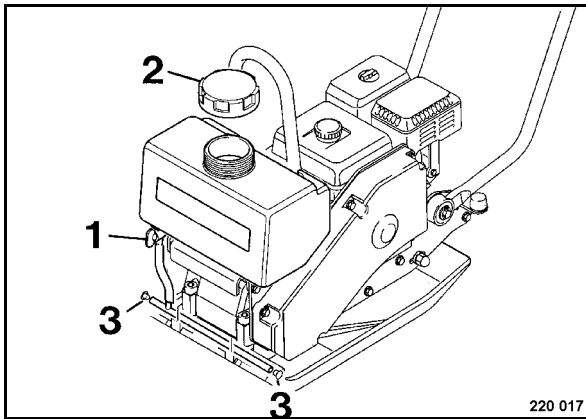

Fig. 60

- Remove the cover (2) (Fig. 60) from the water tank and the lateral rubber cap (3) from the sprinkler tube.
- Open the shut-off cock (1).
- Flush the water tank with a strong water jet, until all dirt has run out.
- Press the rubber cap back on.

⚠ Caution

In case of frost drain the water tank completely.

* Optional equipment

5.23 Tightening the screws

i Note

Self locking nuts must always be replaced by new ones after they have been unscrewed.

Bolt dimensions	Tightening torques* ft - lb		
	8.8	10.9	12.9
M4	2	3	4
M5	4	7	7
M6	7	11	13
M8	18	26	33
M10	37	55	61
M12	65	91	108
M14	101	145	173
M16	156	221	264
M18	213	303	361
M20	304	426	513
M22	413	559	695
M24	524	738	885
M27	774	1092	1308
M30	1047	1482	1770

Fig. 61

*Strength classes for screws with untreated, non-lubricated surfaces. The quality designations are stamped on the screw heads.

8.8 = 8 G

10.9 = 10 K

12.9 = 12 K

The values result in a 90% utilization of the screw's yielding point at a coefficient of friction of μ total = 0.14.

The compliance with the tightening torques is to be checked with torque wrenches.

The tightening torques are not applicable when using MoS₂ lubricants.

5.24 Engine conservation

⚠ Danger

Fire hazard!

When working on the fuel system do not use open fire, do not smoke, do not spill any fuel.

⚠ Danger

Health hazard!

Do not inhale any fuel fumes.

🌿 Environment

Catch running out fuel, do not let it seep into the ground.

If the engine is to be shut down for a longer period of time (e.g. over winter), we recommend the following engine conservation measures to avoid corrosion:

Clean the engine:

- For this purpose use cold cleansing agent or, even better, a steam cleaner.
- Run the engine warm and shut it down.
- Drain the still warm engine oil and fill in fresh engine oil.
- Drain the fuel from the tank.

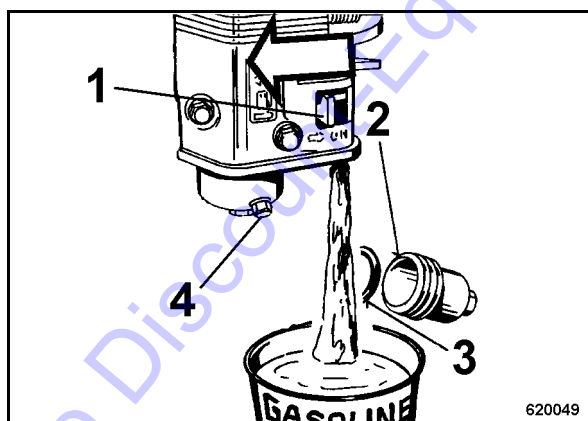

Fig. 62

- Open the fuel tap (1) (Fig. 62) in direction of arrow.

- Unscrew the fuel sludge filter (2), empty it and reassemble it leak tight with a new seal ring (3).
- Unscrew the carburettor drain screw (4), let all fuel run out of the carburettor and turn the screw tightly back in again.

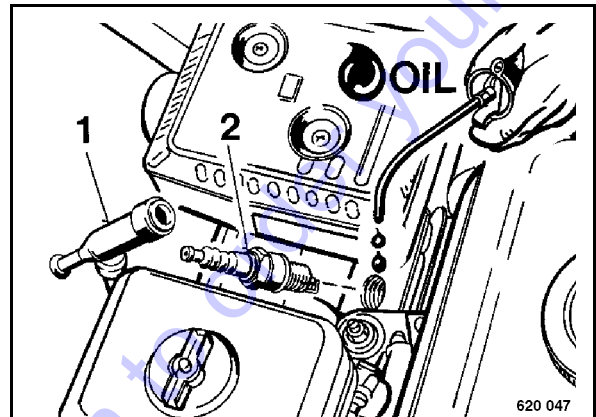

Fig. 63

- Pull off the spark plug socket (1) (Fig. 63) and unscrew the spark plug (2).
- Fill in several drops of fresh engine oil through the ignition plug opening.
- Crank the engine several times with the recoil starter to distribute the oil.
- Screw the spark plug back in.

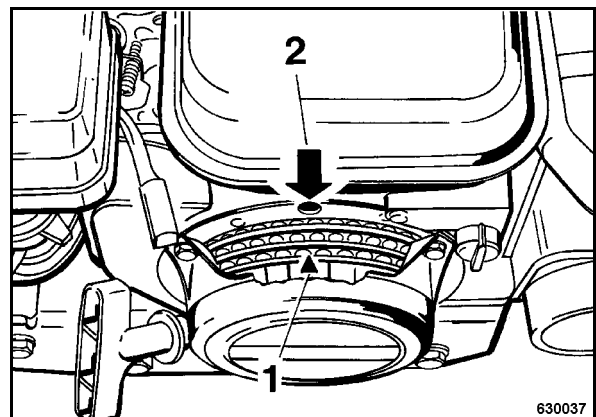

Fig. 64

- For this purpose align triangle mark (1) (Fig. 64) on the starter disc to the top bore (2).

As required

i Note

Intake and exhaust valves closed. The combustion chamber is protected against corrosion.

- Cover the engine to protect it against dust and moisture.

i Note

Depending on weather conditions these conservation measures will protect the machine for approx. 6 to 12 months.

⚠ Caution

A machine with conserved engine must be clearly marked by attaching a clear warning tag.

Go to Discount-Equipment.com to order your parts

6 Trouble shooting

Go to Discount-Equipment.com to order your parts

6.1 General Troubleshooting Instructions

The following work must only be carried out by qualified and trained personnel or by the BOMAG sales service.

Refer to the safety regulations in Section 2 of these operating and maintenance instructions.

Faults are frequently due to the fact that the machine has not been operated or maintained correctly. Therefore, whenever a fault occurs, carefully read through the instructions on correct operation and maintenance. If you cannot locate the cause of the fault or cannot eliminate it yourself using the troubleshooting chart, you should contact the customer service departments at our branch offices or dealers.

On the following pages you will find a selection of fault remedies. It goes without saying that not all causes of faults can be listed.

Go to Discount-Equipment.com to order your parts

6.2 Engine Troubleshooting Chart

Faults	Possible cause	Remedy
Engine does not start	Fuel tank empty Fuel system clogged Fuel nozzle clogged No ignition spark Ignition switch defective	Refuel Clean fuel strainer in carburettor Clean fuel nozzle Exchange spark plug Have damage repaired Exchange ignition switch
Engine is not cranked when starter operated	Starter defective	Exchange starter
Engine stalls frequently at short intervals	Fuel strainer in carburettor clogged	Clean strainer
Engine does not work at full speed	Throttle defective Air filter clogged Engine defective Carburettor defective	Have damage repaired Clean or exchange filter cartridge Exchange engine/ Have damaged repaired Exchange carburettor
Engine runs at high speed, but no vibration	Centrifugal clutch defective V-belt cracked	Exchange centrifugal clutch Exchange V-belt

Go to Discount-Equipment.com to order your parts

PARTS FINDER

**Search Website
by Part Number**



**Search Manual
Library For Parts
Manual & Lookup Part
Numbers – Purchase
or Request Quote**

Search Manuals

Enter your information to help us find the right parts manual for your machine.

* Brand:

* Model:

* Serial:

* Part Number:

SEARCH

**Can't Find Part or
Manual? Request Help
by Manufacturer,
Model & Description**

Parts Order Form

Please fill in the following information to help us find the right part for your machine.

Manufacturer:	<input type="text"/>
Model:	<input type="text"/>
Description:	<input type="text"/>
Part Number:	<input type="text"/>
Quantity:	<input type="text"/>
Notes:	<input type="text"/>

Discount-Equipment.com is your online resource for quality parts & equipment.

Florida: **561-964-4949** Outside Florida TOLL FREE: **877-690-3101**

Need parts?

Click on this link: <http://www.discount-equipment.com/category/5443-parts/> and choose one of the options to help get the right parts and equipment you are looking for. Please have the machine model and serial number available in order to help us get you the correct parts. If you don't find the part on the website or on one of the online manuals, please fill out the request form and one of our experienced staff members will get back to you with a quote for the right part that your machine needs.

We sell worldwide for the brands: Genie, Terex, JLG, MultiQuip, Mikasa, Essick, Whiteman, Mayco, Toro Stone, Diamond Products, Generac Magnum, Airman, Haulotte, Barreto, Power Blanket, Nifty Lift, Atlas Copco, Chicago Pneumatic, Allmand, Miller Curber, Skyjack, Lull, Skytrak, Tsurumi, Husquvarna Target, Stow, Wacker, Sakai, Mi-T-M, Sullair, Basic, Dynapac, MBW, Weber, Bartell, Bennar Newman, Haulotte, Ditch Runner, Menegotti, Morrison, Contec, Buddy, Crown, Edco, Wyco, Bomag, Laymor, EZ Trench, Bil-Jax, F.S. Curtis, Gehl Pavers, Heli, Honda, ICS/PowerGrit, IHI, Partner, Imer, Clipper, MMD, Koshin, Rice, CH&E, General Equipment, Amida, Coleman, NAC, Gradall, Square Shooter, Kent, Stanley, Tamco, Toku, Hatz, Kohler, Robin, Wisconsin, Northrock, Oztec, Toker TK, Rol-Air, APT, Wylie, Ingersoll Rand / Doosan, Innovatech, Con X, Ammann, Mecalac, Makinex, Smith Surface Prep, Small Line, Wanco, Yanmar