

Honda Engines Parts & Accessories

A genuine part can make the difference



Engine models



Engine model	Model code	Engine serial no	
		From	To
G 100K1	G100-	2000001	2424874
G 100K2	G100-	3000001	9999999
G 150	G150-	1000001	9000000
G 150K1	G150-	9100001	9999999
G 200	G200-	1000001	9000000
G 200K1	G200-	9100001	9999999
GC 135	GCAJ-	1000001	9999999
GC 160	GCAH(A)-	1000001	9999999
GC 190A	GCAAA	1000001	9999999
GX 22	GCAF-	1000001	9999999
GX 31	GCAG-	1000001	9999999
GX 35	GCACM	1000001	9999999
GX 25	GCAAM-	1000001	9999999
GXH 50	GCAL-	1000001	9999999
GX 100	GCANM-	1000001	9999999
GX 120K1	GC01-	2000001	9999999
GX 120T1	GCAAT	1000001	9999999
GX 160K1	GC02-	2000001	9999999
GX 160T1	GCABT	1000001	9999999
GX 200	GCAF-	1000001	9999999
GX 200T	GCACT	1000001	9999999
GX 240K1	GC04-	3000001	9999999
GX 270	GCAB-	1000001	9999999
GX 340K1	GC05-	2000001	9999999
GX 390T1	GCAET	1000001	9999999
GX 390K1	GCAA-	2000001	9999999
GX 360K1	GA01-	1100001	9999999
GX 640	GAAD-	1000001	9999999
GX 610	GCAC-	1000001	1999999
GX 620	GCAD-	1000001	1999999
GX 610K1	GCAC-	2000001	9999999
GX 620K1	GCAD-	2000001	9999999
GX 670	GCAM-	1000001	9999999
GS 160A	GCABA	1000001	9999999
GS 190A	GCACA	1000001	9999999
GV 100K1	GV100-	2000001	2999999
GV 100K2	GV100-	9100001	9999999
GCV 135	GJAF-	1000001	9999999
GCV 135E	GJAFE-	1000001	9999999
GCV 160A	GJAEA-	1000001	9999999
GCV 160	GJAE-	1000001	9999999
GCV 190A	GJAAA	1000001	9999999
GCV 520	GJAKM-/GJANM-	1000001	9999999
GCV 530	GJAJM-/GJAMM-	1000001	9999999
GXV 50	GJAG-	1000001	9999999
GXV 120	GXV120-	1000001	9999999
GXV 140	GJAB-	6000001	9999999
GXV 160	GJ03-	1000001	5999999
GXV 160K1	GJ03-	6000001	9999999
GXV 160H2	GJAAH	1000001	9999999
GXV 270K1	GJ01-	2000001	9999999
GXV 340T2	GJABT	1000001	9999999
GXV 340K1	GJ02-	1100001	5999999
GXV 340K2	GJ02-	6000001	9999999
GXV 390T1	GJAAT	1000001	9999999
GXV 390K1	GJAA-	6000001	9999999
GXV 520	GJAPM-	1000001	9999999
GXV 530	GJARM-	1000001	9999999
GXV 610	GJAC-	1000001	1999999
GXV 620	GJAD-	1000001	1999999
GXV 610K1	GJAC-	2000001	9999999
GXV 620K1	GJAD-	2000001	9999999
GXV 670	GJAH-	1000001	9999999
GSV 160A	GJABA	1000001	9999999
GSV 190A	GJACA	1000001	9999999

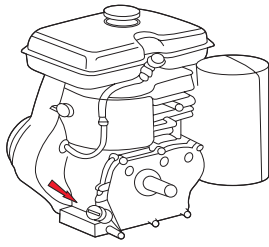

G 100/150/200

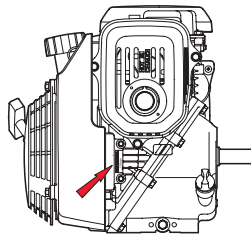

GC 135/160/190 - GS 160/190

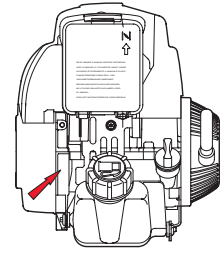

GX 22/31

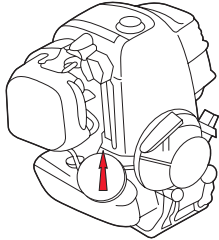

GX 25 - GX 35

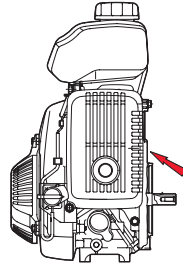

GXH 50

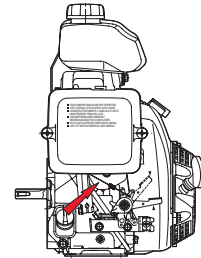

GX 100

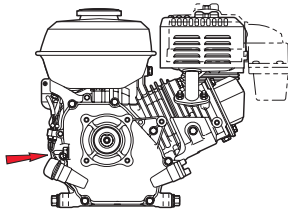

GX 120/160/200/240/270/340/390

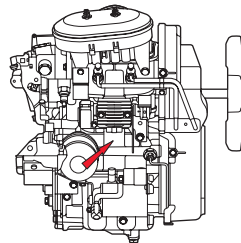

GX 360K1 - GX640

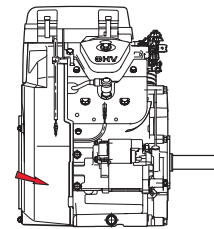

GX 610/620/670

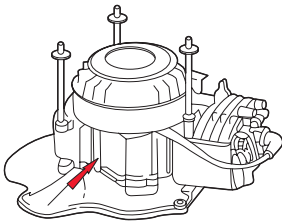

GV 100

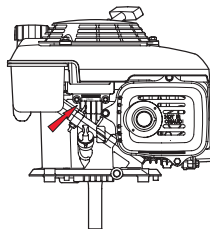

GCV 135/160/190 - GSV 160/190

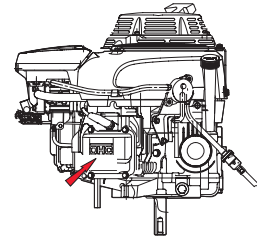

GCV 520/530

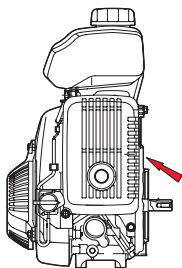

GXV 50

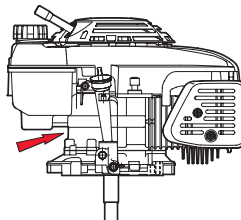

GXV 120/140/160 - GXV 160K1

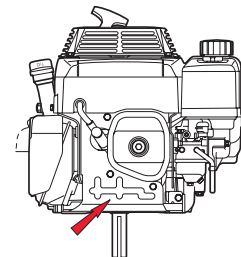

GXV 270/340

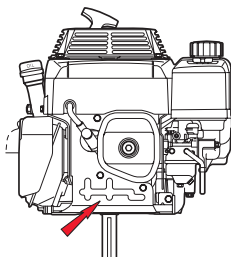

GXV 390

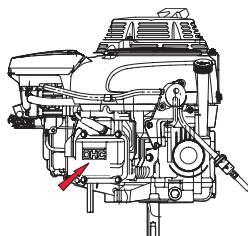

GXV 520/530

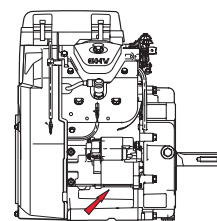

GXV 610/620/670

Recoil starting system

Engine model	REF. 1	REF. 2	REF. 3	REF. 4	REF. 5	REF. 6	REF. 7
	Starter ratchet	Return spring	Reel	Starter spring	Case comp.	Grip	Complete starter assy.
G 100K1	28422-896-010	28443-896-000	28420-ZG0-004	28442-ZE6-003	28410-ZG0-014ZB(RED)	28461-ZH8-003	28400-ZG0-004ZG(RED)
G 100K2					28410-ZG0-014ZB(RED)/ZA(BLACK)		28400-ZG0-004ZG(RED)/ZA(BLACK)
G 150	28422-883-020	-	28420-889-010	28442-883-000	28410-883-030ZB(RED)	28461-883-000	28400-883-040ZB(RED)
G 150K1	28422-883-T20	-	28421-883-T20	28442-883-T20	28410-883-T20ZA(RED)	28461-883-T20	28400-883-T20ZA(RED)
G 200	28422-883-020	-	28420-889-010	28442-883-000	28410-883-030ZB(RED)	28461-883-000	28400-883-040ZB(RED)
G 200K1	28422-883-T20	-	28421-883-T20	28442-883-T20	28410-883-T20ZA(RED)	28461-883-T20	28400-883-T20ZA(RED)
GC 135	-	-	-	-	-	28461-ZL8-003	28400-ZL8-013ZA(BLACK)/ZC(RED)
GC 160	-	-	-	-	-		
GS 160A							
GS 190A							
GC 190A							
GX 22	-	-	28421-ZM3-003	28442-ZM3-003	28414-ZM3-003	28461-ZM3-003	28400-ZM3-003ZA
GX 31	-	-					
GX 35			28421-ZM3-003	28442-ZM3-003			28400-Z02-003
GX 25	-	-	28421-Z0H-003	28442-Z0H-003	28414-Z0H-003	28461-ZM3-003	28400-Z0H-003
GXH 50	-	-	28421-ZM7-003	-	28414-ZM7-003	28461-ZM3-003	28400-ZM7-003
GX 100 STD	-	-	-	-	-	28461-Z0D-003	28400-Z0D-003ZB(BLACK)/ZC(RED)
GX 100 TAMP	28422-ZG0-W02	-	28421-Z0D-W02	28442-ZH8-003	28410-Z0D-V02ZA	28461-ZH8-003	28400-Z0D-V02ZA(BLACK)
GX 120K1	28422-ZH8-013	28443-ZH8-003	28420-ZH8-013	28442-ZH8-003	28410-ZH8-003YA(RED)/ZB(BLACK)	28461-ZH8-003	28400-ZH8-013YA(RED)/023ZB(BLACK)
					⚠ WARNING: As from engine number 4363434:		28400-ZH8-023YA
GX 120T1	28422-ZH8-013	28443-ZH8-003	28420-ZH8-013	28442-ZH8-003	28410-ZH8-003YA(RED)/ZB(BLACK)	28461-ZH8-003	28400-ZH8-013YA(RED)/023ZB(BLACK)
					⚠ WARNING: As from engine number 1154037:		28400-ZH8-023YA
GX 160K1	28422-ZH8-013	28443-ZH8-003	28420-ZH8-013	28442-ZH8-003	28410-ZH8-003YA(RED)/ZB(BLACK)	28461-ZH8-003	28400-ZH8-013YA(RED)/023ZB(BLACK)
					⚠ WARNING: As from engine number 8805658:		28400-ZH8-023YA
GX 160T1	28422-ZH8-013	28443-ZH8-003	28420-ZH8-013	28442-ZH8-003	28410-ZH8-003YA(RED)/ZB(BLACK)	28461-ZH8-003	28400-ZH8-013YA(RED)/023ZB(BLACK)
					⚠ WARNING: As from engine number 1411006:		28400-ZH8-023YA
GX 200	28422-ZH8-013	28443-ZH8-003	28420-ZH8-013	28442-ZH8-003	28410-ZH8-003YA(RED)/ZB(BLACK)	28461-ZH8-003	28400-ZH8-013YA(RED)/023ZB(BLACK)
					⚠ WARNING: As from engine number 1937023:		28400-ZH8-023YA
GX 200T1	28422-ZH8-013	28443-ZH8-003	28420-ZH8-013	28442-ZH8-003	28410-ZH8-003YA(RED)/ZB(BLACK)	28461-ZH8-003	28400-ZH8-013YA(RED)/023ZB(BLACK)
					⚠ WARNING: As from engine number 1129302:		28400-ZH8-023YA
GX 240K1	28422-ZE2-W01	28443-ZE2-W01	28421-ZE2-W01	28442-ZE2-W01	28410-ZE2-W01ZN(RED)/ZB(BLACK)	28461-ZE2-W02	28400-ZE2-W01ZN(RED)/ZB(BLACK)
GX 270							
GX 340K1			28421-ZE3-W01		28410-ZE3-W01ZP(RED)/ZB(BLACK)		28400-ZE3-W01ZP(RED)/ZB(BLACK)
GX 390T1							
GX 390K1							
GX 360K1	NO RECOIL STARTER, ONLY WITH STARTER MOTOR						
GX 640							
GX 610	28422-ZE2-W01	28443-ZE2-W01	28421-ZE3-W01	28442-ZE2-W01	28410-ZE3-W01ZP(RED)/ZB(BLACK)	28461-ZE2-W02	28400-ZE3-W01ZP(RED)/ZB(BLACK)
GX 620					28410-ZE3-W01ZB(BLACK)		28400-ZE3-W01ZB(BLACK)
GX 610K1					28410-ZE3-W01ZP(RED)/ZB(BLACK)		28400-ZE3-W01ZP(RED)/ZB(BLACK)
GX 620K1							28400-ZE3-W01ZP(RED)/ZB(BLACK)
GX 670	NO RECOIL STARTER, ONLY WITH STARTER MOTOR						
GV 100K1	28422-896-010	-	28420-ZG1-702	28442-ZE6-003	28410-ZG1-702ZD(RED)	28461-ZE7-T00	28400-ZG1-T12ZC(RED)/ZB(BLACK)
GV 100K2	28422-ZL1-003	-	28421-ZL1-003	28442-ZH8-003	-		28400-ZL1-003
GCV 135	-	-	-	-	-	28461-ZL8-003	28400-ZM0-632ZA(BLACK)
GCV 135E							
GCV 160A							28400-ZL8-013ZA(BLACK)/ZC(RED)
GCV 160							28400-ZM0-632ZA(BLACK)
GSV 160A							28400-ZM0-632ZA(BLACK)/ZD(RED)
GSV 190A							28400-Z0Y-003ZA(RED)/ZB(BLACK)
GCV 190A							28400-Z0Y-003ZA(RED)/ZB(BLACK)
GCV 520	NO RECOIL STARTER, ONLY WITH STARTER MOTOR						
GCV 530							
GXV 50	-	-	28421-ZM7-003	-	28414-ZM7-003	28461-ZM3-003	28400-ZM7-003
GXV 120	28422-896-010	28443-896-000	28420-ZE6-003	28442-ZE6-003	28410-ZE6-003ZA(RED)/ZB(BLACK)	28461-ZE1-003	28400-ZE6-003ZD(RED)/ZB(BLACK)
GXV 140	28486-ZE6-T02	28486-ZE6-T02	-	-	28402-ZG9-802	28461-ZE6-T02	28400-ZG9-803
GXV 160	28422-896-010	28443-896-000	28420-ZE7-003	28442-896-700	28410-ZE7-003ZD(RED)	28461-ZE1-003	28400-ZE7-003ZC(RED)
GXV 160H2							
GXV 160K1	28486-ZE6-T02	28486-ZE6-T02	-	-	28402-ZG9-802	28461-ZE7-T00	28400-ZG9-803
GXV 270K1	28422-ZE2-W01	28443-ZE2-W01	28421-ZE3-W01	28442-ZE2-W01	28410-ZE8-004ZB(RED)/ZA(BLACK)	28461-ZE2-W02	28400-ZE8-004ZD(RED)/ZA(BLACK)
GXV 340K1					28410-ZE8-004ZB(RED)		28400-ZE8-004ZD(RED)
GXV 340T2			28421-ZE3-W01		28410-ZE3-W01ZP(RED)		28400-ZE3-W01ZP(RED)
GXV 340K2			28421-ZE8-821		28410-ZE3-W01ZP(RED)/ZB(BLACK)		28400-ZE3-W01ZP(RED)/ZB(BLACK)
GXV 390T1			28421-ZE3-W01		28410-ZE3-W01ZP(RED)		28400-ZE3-W01ZP(RED)
GXV 390K1			28421-ZE3-W01		28410-ZE3-W01ZP(RED)		28400-ZE3-W01ZP(RED)
GXV 520	NO RECOIL STARTER, ONLY WITH STARTER MOTOR						
GXV 530							
GXV 610	28422-ZE2-W01	28443-ZE2-W01	28421-ZE3-W01	28442-ZE2-W01	28410-ZE3-W01ZP(RED)/ZB(BLACK)	28461-ZE2-W02	28400-ZE3-W01ZP(RED)/ZB(BLACK)
GXV 620							
GXV 610K1					28410-ZE3-W01ZP(RED)		28400-ZE3-W01ZP(RED)
GXV 620K1					28410-ZE3-W01ZP(RED)/ZB(BLACK)		28400-ZE3-W01ZP(RED)/ZB(BLACK)
GXV 670	NO RECOIL STARTER, ONLY WITH STARTER MOTOR						

Fuel system



REF. 1



REF. 2



REF. 3



REF. 4



REF. 5



REF. 6



REF. 7

Engine model	REF	Fuel tank cap
G 100K1, G 100K2, G 150K1, G 200K1, GX 120K1/T1, GX 160K1/T1, GX 200/T1, GX 240K1, GX 270, GX 340K1, GX 390K1/T1, GX 610, GX 390K1/T1, GX 610	1bis	17620-ZH7-023
G 150, G 200	1bis	17620-883-770
GX 120T1, GX 160T1, GX 200T	1a	17620-Z07-811
GX 22, GX 31, GX 25, GX 35	1	17620-ZM3-043
GXH 50	1	17620-ZL8-013
GX 620	1	17620-899-013
GX 620K1	1	17620-ZJ1-840
GV 100K1	1	17620-ZG1-000
GV 100K2, GXV 140	1	17620-ZG9-000
GXV 50	1	17620-ZV0-020
GXV 120, GXV 160, GXV 160K1/H2, GXV 270K1, GXV 340K1, GXV 340K2/T2, GXV 390K1/T1	1	17620-ZE7-000
GC 135, GC 160, GS 160, GS 190, GC 190, GX 100, GCV 135, GCV 160, GCV 190, GSV 160, GSV 190	1	17620-ZL8-013
Engine model		Fuel filter
G 100K1, G 150, G 200	2	17672-880-000
GX 22, GX 31, GX 25, GX 35	3	17672-ZM3-003
GX 620, GX 620K1	2	17672-899-000
GXV 270K1, GXV 340K2/T2, GX 120K1/T1, GX 160K1/T1, GX 200/T, GX 240K1, GX 270, GX 340K1, GX 390K1/T1, G 100K2, G 150K1, G 200K1	2	17672-ZE2-W01
Engine model		Fuel cock
GX 160K1, GX 200	4	16950-898-633
GX 620	4	16950-ZA0-013
GX 610, GX 620K1	4	16950-YA0-802
GV 100K2	5	16950-ZL1-000
GCV 135, GCV 160, GXV 140, GXV 50, GSV 160, GSV 190	5	16950-ZG9-M03
G 150, G 200	4	16950-883-663
G 150K1, G 200K1	4	16950-883-703

* = diameter of body fuel filter inside fuel tank



REF. 1bis



REF. 1a



REF. 1



REF. 2



REF. 3



REF. 4



REF. 5

Gasket

Engine model	Gasket kit	Cylinder head gasket	Oil pan packing	Head cover packing	Exhaust pipe gasket
GV100K2	-	12281 ZC0 003	11381 ZL1 000	12375 ZG1 000	
GXV120	06111-ZE6-406	12251-ZE6-000	11381-ZG9-J60	12391-ZE7-M10	18381-ZE6-800
GXV140	06111-ZG9-406	12251-ZG9-000	11381-ZG9-T00		18381-ZG9-M00
GXV160	06111-ZE7-406	12251-ZE7-000	11381 ZE7 M10	12391-ZE7-M10	18381-ZG9-M00
GXV160K1	061A1-ZE7-T00				
GXV160H2					18381-ZE6-820
GXV270K1	06111-ZE8-405	12251-ZE8-020	11381-ZE9-801	12391-ZE8-000	18333-ZE3-800
GXV340K1	-	12251-ZE9-600			
GXV340K2/T2	06111-ZE9-V01				
GXV390K1	-	12251-ZF5-000			
GXV390T1	-	12251-ZF5-H01			
G100K1	06111-ZG0-405	12281-ZG0-003	11381 ZG0 800	12375 ZG0 010	18381 ZG0 800
G100K2	06111-ZG0-406	12281-ZC0-003			
G150	06111-887-406	12281-887-306	11381 883 800	12375 887 000	18381 883 800
G150K1	-				
G200	06111-883-405	12281-883-801		12375 883 000	
G200K1	-				
GX120K1/T1	06111-ZH7-405	12251-ZH7-800	11381-ZH7-800	12391 ZE1 000	18381 ZH8 800
GX160K1/T1	06111-ZH8-405	12251-ZF1-800	11381-ZL0-000		
GX200/T	06111-ZL0-000	12251-ZL0-003			
GX240K1	06111-ZE2-408	12251-ZE2-800	11381-ZE2-801	12391 ZE2 020	18381 ZE2 800
GX270	06111-ZH9-405	12251-ZH9-000			
GX340K1	06112-ZE3-405	12251-ZE3-W00	11381-ZE3-801		
GX390K1/T1	06111-ZF6-R81	12251-ZF6-W00			
GX610 / 620	061A1-ZJ1-000	12251-ZJ1-003	11381-ZJ1-000	12391-ZJ1-000	18333-ZJ1-000
GX610 / 620 K1	061A1-ZJ1-001	12251-ZJ1-841	11381-ZJ1-840	12391-ZE2-020	18333 ZE3 800

Important: Oil seals for crankshaft and flywheel are not included in the gasket kit

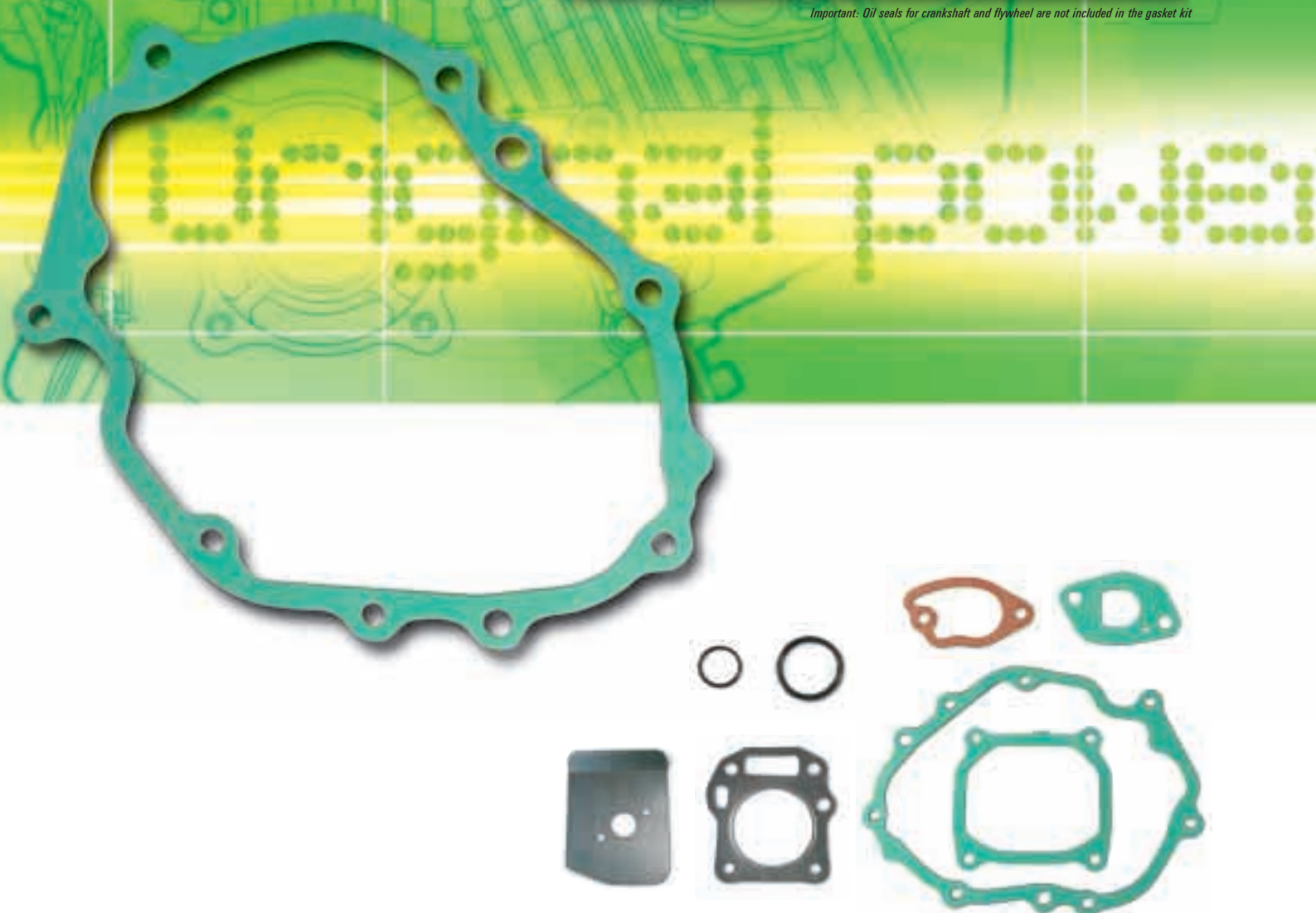

Piston

Engine model	REF 1	Bore diameter in mm	REF 2	REF 3	REF 4	REF 5	Con.rod (-025)
	Piston		Ring set	Piston pin	Piston clip	Con.rod std	
G 100K1	13101-Z60-003*	48	13010-Z60-003*	13111-892-000	13115-147-000	13200-Z60-000	13200-Z60-305
G 100K2	13101-ZC0-003*		13010-ZC0-003*				
G 150	13101-887-003*	64	13010-887-000*	13111-883-000	94601-15000	13200-887-505	13200-887-507
G150K1						13200-887-050	-
G 200	13101-833-003*	67	13010-YA0-004*			13200-883-050	13200-883-506
G 200K1							
GC 135	13101-ZL8-000	64	13010-ZL8-003	13111-ZE0-000	90551-ZE0-000	13200-ZL9-000	-
GC 160						13200-ZL8-000	-
GC 190	13101-Z0Y-000	69	13010-Z0Y-004	13111-Z0Y-000	90551-ZE0-000	13200-Z0Y-000	
GX 22	13101-ZM3-030	33	13010-ZM3-000	13111-ZM3-000	-	-	-
GX 31	13101-ZM5-030	39	13010-ZM5-000	13111-ZM5-000			
GX 25	13101-Z0H-000	35	13010-Z0H-000	13111-Z0H-000			
GX 35	13101-Z0H-000	39	13010-ZM5-000	13111-ZM5-000			
GXH 50	13101-ZM7-010	41,8	13010-ZM7-000	13111-6S7-000	13115-147-000	13200-ZM7-000	-
GX 100 STD	13101-Z0D-000	56	13010-Z0D-003	13111-ZE0-000	90551-ZE0-000	13200-Z0D-000	13200-Z0D-305
GX 100 TAMP							
GX 120K1	13101-ZH7-010*	60	13010-ZK7-V02*	13111-ZE0-000	90551-ZE0-000	13200-ZE0-000	-
GX 120T1	13101-Z0S-810*	60	13010-Z0S-801*	13111-ZE0-000	90551-ZE0-000	13200-Z0S-800	
GX 160K1	13101-ZH8-010*	68	13010-ZH8-941*	13111-ZE1-000	90551-ZE1-000	13200-ZE1-010	-
GX 160T1	13101-Z0T-810*	68	13010-ZL0-003*	13111-ZE1-000	90551-ZE1-000	13200-Z0T-800	
GX 200	13101-ZL0-010*	68	13010-ZL0-003*	13111-ZE1-000	90551-ZE1-000	13200-ZE1-010	132A0-ZE1-000
GX 200T	13101-Z0T-800*	68	13010-Z0T-801*	13111-ZE1-000	90551-ZE1-000	13200-Z0T-800	
GX 240K1	13101-ZE2-W00*	73	13010-ZE2-013*	13111-ZE2-000	90551-ZE1-000	13200-ZE2-010	13200-ZE2-305
GX 270	13101-ZH9-000*	77	13010-ZE8-601*				
GX 340K1	13101-ZE3-W00*	82	13010-ZE3-003*	13111-ZF6-000	90601-ZE3-000	13200-ZE3-020	13200-ZE3-315
GX 390K1	13101-ZF6-W00*	88	13010-ZF6-003*	13111-ZF6-W00			
GX 390T1	13101-ZF6-W00*	88	13010-Z1C-800*	13111-ZF6-W00		13200-Z1C-000	
GX 360K1	13101-ZA0-010*	58	130A1-ZA0-004*	13111-881-000	94601-14000	13210-ZA0-000	-
GX 640	13101-ZG8-000*	76	13010-ZG8-004*	13111-ZG8-000	94601-19000	13210-ZG8-000	-
GX 610	13101-ZJ1-000*	77	13010-ZE8-601*	13111-ZJ1-000	90551-ZE1-000	13210-ZJ1-000	-
GX 620							
GX 610K1	13101-ZJ1-840*		13010-ZJ1-841*	13111-ZJ1-840	94601-18000	13200-ZJ1-841	
GX 620K1							
GX 670	13101-ZN1-000*					13200-ZN1-003	
GS 160	13101-Z2A-004	64	13010-Z2A-004	13111-ZE0-000	90551-ZE0-000	13200-ZL8-000	
GS 190	13101-Z0Y-004	69	13010-Z2C-004	13111-Z0Y-000	90551-ZE0-000	13200-Z0Y-000	
GV 100K1	13101-ZC0-003	52	13010-ZG1-U11	13111-892-000	13115-147-000	13200-Z60-000	-
GV 100K2							
GCV 135	13101-ZL8-000	64	13010-ZL8-003	13111-ZE0-000	90551-ZE0-000	13200-ZL8-000	-
GCV 135E							
GCV 160A							
GCV 160							
GCV 190	13101-Z0Y-000	69	13010-Z0Y-004	13111-Z0Y-000	90551-ZE0-000	13200-ZY0-000	
GCV 520	13101-Z0A-000	77	13010-Z0A-014	13111-ZJ1-840	90551-ZE1-000	13200-Z0A-003	-
GCV 530	13101-Z0A-800		13010-ZJ1-841		90551-ZE1-000	13200-Z0A-003	
GXV 50	13101-ZM7-010	41,8	13010-ZM7-000	13111-6S7-000	13115-147-000	13200-ZN4-000	-
GXV 120	13101-ZE6-033*	60	13010-ZE6-013*	13111-ZJ1-840	90551-ZE1-000	13200-Z0A-003	-
GXV 140	13101-ZG9-010*	64	13010-ZG9-003*	13111-ZE0-000	90551-ZE0-000	13200-ZE6-010	
GXV160	13101-ZE7-020*	68	13010-ZF1-024*	13111-ZE1-000	90551-ZE1-000	13200-ZE7-000	13200-ZE7-305
GXV 160K1			13010-ZF1-023*				-
GXV 160H2	13101-ZH8-010*	68	13010-ZL0-003*	13111-Z1T-000	90551-ZE1-000	13200-Z1V-000	
GXV 270K1	13101-ZE8-010*	77	13010-ZE8-601*	13111-ZE2-000	90551-ZE1-000	13200-ZE8-010	13200-ZE8-305
GXV 340K1	13101-ZE3-000*	82	13010-ZE3-003*	13111-ZF6-000	90601-ZE3-000	13200-ZE9-020	13200-ZE9-315
GXV 340T2	13101-ZE3-W00*		13010-Z1F-800*	13111-ZE3-000		13200-Z1E-000	13200-Z1E-305
GXV 340K2	13101-ZE3-W00*		13010-ZE3-003*			13200-ZE9-020	13200-ZE9-315
GXV 390T1	13101-ZF6-W00*	88	13010-Z1C-800*	13111-ZF6-000		13200-Z1E-000	13200-Z1E-305
GXV 390K1	13101-ZF6-W00*	88	13010-ZF6-003*	13111-ZF6-000		13200-ZE9-020	13200-ZE9-315
GXV 520	13101-Z0A-000	77	13010-Z0A-003	13111-ZJ1-840	90551-ZE1-000	13200-Z0A-801	-
GXV 530							
GXV 610	13101-ZJ1-010*	77	13010-ZE8-601*	13111-ZJ1-000	90551-ZE1-000	13210-ZJ1-000	-
GXV 620							
GXV 610K1	13101-ZJ1-840*		13010-ZJ1-841*	13111-ZJ1-840	94601-18000	13200-ZJ1-841	
GXV 620K1							
GXV 670	13101-ZN1-000*		13010-ZJ1-841*	13111-ZJ1-840		13200-ZN1-003	
GSV 160	13101-Z2A-000	64	13010-Z2A-004	13111-ZE0-000	90551-ZE0-000	13200-ZL8-000	
GSV 190	13101-Z0Y-000	69	13010-Z2C-004	13111-ZY0-000	90551-ZE0-000	13200-ZY0-000	

* = oversize pistons/rings sets are available



REF. 1

REF. 2

REF. 3

REF. 4

REF. 5

Ignition coil

Engine model	REF.	Ignition coil
G 100K1	1	30500-ZG0-813
G 100K2	1	30500-ZG0-W01
G 150	3	30560-887-T00
G 150K1	1	30500-883-R51
G 200	3	30560-883-015
G 200K1	1	30500-883-R51
GC 135	1	30500-ZL8-004
GC 160		
GC 190		30500-Z0J-003
GX 22	1	30500-ZM3-003
GX 31		
GX 35		30500-Z0Z-003
GX 25	1	30500-Z0H-013
GXH 50	1	30500-ZM7-004
GX 100 STD	1	30500-Z0D-003
GX 100 TAMP	1	30500-Z0D-V01
GX 120K1	2	30500-ZE1-043
GX 120T1		30500-Z0T-801
GX 160K1		30500-ZE1-043
GX 160T1		30500-Z0T-801
GX 200		30500-ZE1-043
GX 200T		30500-Z0T-801
GX 240K1	2	30500-ZF6-W02
GX 270		
GX 340K1		
GX 390K1		
GX 390T1		
GX 360K1	5	30500-ZA0-701 (CYL. 1 + CYL. 2)
GX 640	3	30500-ZG8-003 (CYL. 1 + CYL. 2)
GX 610	2	30500-ZJ1-023(CYL.1)/30550-ZJ1-023(CYL.2)
GX 620		
GX 610K1	2	30500-ZJ1-842(CYL.1)/30550-ZJ1-842(CYL.2)
GX 620K1		
GX 670		
GS 160	1	30500-Z0J-003
GS 190		
GV 100K1	1	30500-ZG1-U10
GV 100K2		30500-ZL1-004
GCV 135	1	30500-ZL8-004
GCV 135E		
GCV 160A		
GCV 160		
GCV 190		30500-Z0J-003
GCV 520	1	30500-Z0A-013(CYL.1)/30550-Z0A-013(CYL.2)
GCV 530		
GXV 50	1	30500-ZM7-004
GXV 120	2	30500-ZG9-M03
GXV 140	1	30500-ZG9-801
GXV 160	2	30500-ZE7-043
GXV 160H2		30500-Z1V-003
GXV 160K1	2	30500-ZG9-801
GXV 270K1	2	30500-ZF5-003
GXV 340K1	2	30500-ZE9-L33
GXV 340K2		
GXV 340T2		30500-Z1E-L01
GXV 390T1		
GXV 390K1		30500-ZE9-L33
GXV 520	1	30500-Z0A-013(CYL.1)/30550-Z0A-013(CYL.2)
GXV 530		
GXV 610	2	30500-ZJ1-023(CYL.1)/30550-ZJ1-023(CYL.2)
GXV 620		
GXV 610K1	2	30500-ZJ1-842(CYL.1)/30550-ZJ1-842(CYL.2)
GXV 620K1		
GXV 670		
GSV 160	1	30500-Z0J-003
GSV 190		



REF. 1



REF. 2



REF. 3



REF. 4



REF. 5

Aircleaner

Engine model	REF.	Aircleaner	Outer filter	Dimensions			Material / shape
				Long.	Width	Height	
G 100K1, G100K2	1	17211-896-000		94	76	25	urethane, rectangle
G 150, G 200	2	17211-883-010		120	120	40	urethane, round
G 150K1, G 200K1	3	17211-883-W21	17218-883-W21	178	89	29	paper, rectangle
GC 135/160/190, GS 160/190, GCV 135/160/190, GSV 160/190	3	17211-ZL8-003		133	115	21	paper, rectangle
GX 25, GX 35	4	17211-Z0H-000		76	83	20	urethane, +/- oval
GX 22, GX 31	5	17211-ZM3-000		72	72	20	urethane, round
GXH 50, GXV 50	1	17211-ZM7-000		89	89	12	urethane, square
GX 100 STD, GX 100 TAMPER	3	17211-ZL8-003	17218-Z0D-000	133	115	21	paper, rectangle
GX 120K1, GX 120T1	6	17210-ZE0-505*	17218-ZE0-505	102	74	52	paper, oval(out filt.urethane)
GX 160K1, GX 160T1, GX 200, GX 200T	6	17210-ZE1-505*	17218-ZE1-505	102	74	71	paper, oval(out filt.urethane)
GX 240K1, GX 270	6	17210-ZE2-515*	17218-ZE2-505	155	121	40	paper, oval(out filt.urethane)
GX 340K1, GX 390K1, GX 390T1	6	17210-ZE3-505*	17218-ZE3-505	112	97	92	paper, oval(out filt.urethane)
GX 360K1	6	17210-ZA0-506	17218-ZA0-506	165	105	40	paper, oval(out filt.urethane)
GX 640	7	06172-ZG8-L20	17218-ZG8-000	186	174	34	paper, rectangle
GX 610, GX 620, GXV 610, GXV 620	7	17010-ZJ1-000	17218-ZJ1-000	238	183	32	paper, rectangle
GX 610K1, GX 620K1, GX 670, GXV 610K1, GXV 620K1, GXV 670	8	17210-ZJ1-842	17218-ZJ1-840	225	167	30	paper, rectangle
GV 100K1	9	17211-ZG1-700		130	75	25	urethane, +/--rectangle
GV 100K2	9	17211-ZL1-000		120	70	25	urethane, +/--rectangle
GCV 520, GCV 530, GXV 520, GXV 530	8	17211-Z0A-003	17218-Z0A-000	215	120	22	paper, rectangle
GXV 120	6	17210-ZE6-505*	17218-ZE6-505	190	62	50	paper, oval(out filt.urethane)
GXV 140	7	17211-ZG9-800	17218-ZG9-800	137	61	25	paper, rectangle
GXV 160	6	17210-ZE7-505*	17218-ZE6-505	190	63	45	paper, oval(out filt.urethane)
GXV 160K1, GXV 160H2	6	17211-ZE7-W03*	17218-ZE7-W02	180	62	50	paper, oval(out filt.urethane)
GXV 270K1, GXV 340K1/K2	6	17210-ZF5-505	17218-ZF5-505	124	60	87	paper, oval
GXV 340K2, GXV 340T2, GXV390K1, GXV 390T1	6	17211-ZF5-V01	17218-ZF5-V00	124	60	87	paper, oval

* = aircleaner + outer filter



REF. 1



REF. 2



REF. 3



REF. 4



REF. 5



REF. 6



REF. 7

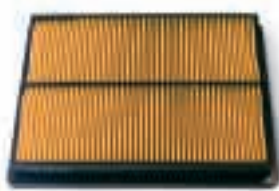

REF. 8



REF. 9

Oilfilter

Engine model	Oilfilter	Ø	Height	Material
GXV 340K2, GXV 610, GXV 610K1, GXV 620, GXV 620K1, GXV 670, GX 610, GX 610K1, GX 620, GX 620K1, GX 670	15400-ZJ1-004	83	82	metal, cyl.
GCV 520, GCV 530, GXV 520, GXV 530	15400-PFB-004	65	65	metal, cyl.
GX 640	15400-PFB-007	69	72	metal, cyl.
GXV 340K1, GXV 390	15400-PLC-004	65	85	metal, cyl.
GX 360K1	15400-679-033	68	67	metal, cyl.



Oilfilter



Fuel strainer

Engine model	Fuel strainer	Small Ø	Big Ø	Height	Material
GCV 530, GC 135, GC 160, GC 190, GXV 520, GXV 530	16910-ZV4-015	22	29	67	plastic
GX 100, GX 120K1/T1, GX 160K1/T1, GX 200/T1, GX 240K1, GX 270, GX 360K1, GX 390K1/T1, GXV 340K1, GXV 340K2, GXV 390K1, GXV 610, GXV 610K1, GXV 620, GXV 620K1, GXV 670, GX 360K1, GX 610, GX 610K1, GX 620, GX 620K1, GX 670, G 100K1, G 100K2, GXV 270K1	16910-GB2-005	23	30	53	plastic
G 100K2	16910-ZE8-015	22	29	65	plastic
GXV 160H2	16910-ZG0-U02	22	29	64	plastic
GXV 390T1	16952-ZA8-800	23	30	53	plastic
	16952-ZE6-000	23	30	53	plastic



Fuel strainer

Spark plugs

Engine model	ND	NGK
G100K1	98073-54754	98073-54744
G100K2		9873-54776
G150	98076-54720	98076-54716
G150	98076-54821 CDI	98076-54911 CDI
G150K1	98076-54780	98076-54710
G200	98076-54720	98076-54716
G200	98076-54921 CDI	98076-54914 CDI
G200K1	98076-54780	98076-54710
GC135		98079-56846
GC160		98079-56846
GC190		98079-56846
GS160		98079-56846
GS190		98079-56846
GX22	98056-55757	98056-55777
GX31		98056-55777
GX25		31915-Z0H-003
GX35		31915-Z0H-003
GXH50		98056-55777
GX100STD	98056-55757	98056-55777
GX100TAMP	98056-55757	98056-55777
GX120K1	98079-56855	98079-56846
GX120T1	98079-56855	98079-56846
GX160K1	98079-56855	98079-56846
GX160T1	98079-56855	98079-56846
GX200	98079-56855	98079-56846
GX200T	98079-56855	98079-56846
GX240K1	98079-56855	98079-56846
GX270	98079-56855	98079-56846
GX340K1	98079-56855	98079-56846
GX390K1	98079-56855	98079-56846
GX390T1	98079-56855	98079-56846
GX360K1		98076-54747
GX340K1	98079-55155	98079-55145
GX610	98079-56855	98079-56846
GX620	98079-56855	98079-56846
GX610K1	98079-5585V	98079-5587V
GX620K1	98079-5585V	98079-5587V
GX670	98079-5585V	98079-5587V
GV100K1	98073-54754	98073-54744
GV100K2		98073-54776
GCV135		98079-56846
GCV160		98079-56846
GCV190		98079-56846
GCV520	98079-55855	98079-56846
GCV530	98079-55855	98079-56846
GSV160		98079-56846
GSV190		98079-56846
GXV50	98056-55757	98056-55777
GXV120	98079-55855	98079-55846
GXV140		98079-55846
GXV160	98079-55855	98079-55846
GXV160K1	98079-55855	98079-55846
GXV160H2	98079-55855	98079-55846
GXV270K1	98079-55855	98079-55846
GXV340K1	98079-55855	98079-55846
GXV340K2		98079-55846
GXV340T2		98079-55846
GXV390K1		98079-55846
GXV390T1		98079-55846
GXV520	98079-55855	98079-55846
GXV530	98079-55855	98079-55846
GXV610		98079-55846
GXV620		98079-55846
GXV610K1	98079-5585V	98079-5587V
GXV620K1	98079-5585V	98079-5587V
GXV670	98079-5585V	98079-5587V



Spark plug

Service kit

Engine model	Service kit	Quantity
GC-GCV 135/160	06211-ZL8-000	1
	06211-ZL8-000MP	multipack of 1x12



4-stroke oil

Engine model	4-stroke oil	Quantity
All engines	08221-99953HD 4 stroke oil 10W30 SJ/SH	25 x 0.1 L
	08221-99955HD 4 stroke oil 10W30 SJ/SH	8 x 0.6 L
	08221-99957HD 4 stroke oil 10W30 SJ/SH	6 x 1 L



25 x 0.1 L



8 x 0.6 L



6 x 1 L

H-HST oil

Engine model	H-HST oil	Quantity
All engines	08208-99901HE H-HST oil	1 x 1 L



1 x 1 L

Accessoires

Cable holder	GX 10 000 000	p. 14
Oil dipstick (205 mm)	GX 120-K10-05	p. 15
Oil dipstick (225 mm)	GX 160-K10-06	p. 16
Oil dipstick (370 mm)	GX 160-K10-26	p. 16
Oil dipstick (255 mm)	GX 340-390-K18 / GX 270-000-07	p. 17
En-guard (plastic type) no deflector	06185-ZF6-W400	p. 18
En-guard (plastic type) with deflector	06185-ZF6-W500	p. 19
En-guard (plastic type) no deflector	06185-ZH8-W400	p. 20
En-guard (plastic type) with deflector	06185-ZH8-W500	p. 21
En-guard (metal type) no deflector	06185-ZH8-W600	p. 22
En-guard no deflector	06185-ZK9-W400	p. 23
En-muffler guard (plastic type) with deflector	06185-ZK9-W500	p. 24
Universal muffler for v-twin engine	06183-ZJ1-BOSU	p. 25
Top mount muffler	06183-ZJ1-BOSL	p. 25
Top mount muffler	06183-ZJ1-BOSR	p. 26
Heat shield	18434-ZJ1-BOS	p. 26
Deflector	18431-ZH8-BOS	p. 27
Exhaust flange	GX620-000001	p. 27
Exhaust pipe	18331-Z0A-SET	p. 28
Deflector (long type)	18431-ZH8-W500	p. 28
Deflector (short type)	GX20-000-00	p. 29
Low noise muffler	18310-ZB8-SIL	p. 29
11 liter fuel tank	17500-GX1-11L	p. 30
18 liter fuel tank	17500-GX1-18L	p. 30

Cable holder

Remote throttle operation for	Partnumber	Packing
GX 120K1, 160K1, 200, 240K1, 270, 340K1, 390K1	GX 10 000 000	50 pieces/set
GX 610K1, 620K1, 670		

REF.	Component name	QTY
1	screw	1
2	cable holder	1
3	E-ring	1



Oil dipstick (205 mm)

Extension of oil level gauge for	Partnumber	Packing
GX 120K1	GX 120-K10-05	1 piece/set

REF.	Component name	QTY
1	oil level dipstick	1
2	screw	1
3	collar	1
4	stay	1

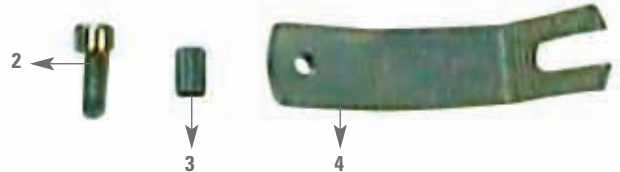

Oil dipstick (225 mm)

Extension of oil level gauge for	Partnumber	Packing
GX 160K1, GX 200	GX 160-K10-06	1 piece/set

REF.	Component name	QTY
1	oil level dipstick	1
2	screw	1
3	collar	1
4	stay	1

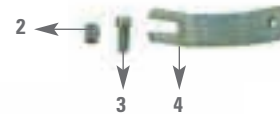

Oil dipstick (370 mm)

Extension of oil level gauge for	Partnumber	Packing
GX 120K1, GX 160K1, GX 200, GX 240K1 GX 270, GX 340K1, GX 390K1	GX 160-K10-26	1 piece/set

REF.	Component name	QTY
1	oil level dipstick	1
2	screw	1
3	collar	1
4	stay	1

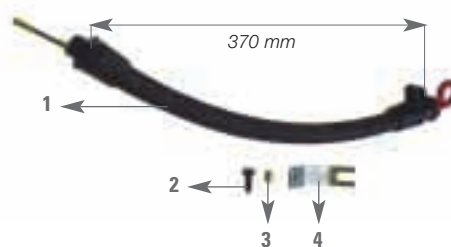

Oil dipstick (255 mm)

Extension of oil level gauge for	Partnumber	Packing
GX 120K1, GX 160K1, GX 200, GX 240K1, GX 270, GX 340K1, GX 390K1	GX 340-390-K18, GX 270-000-07	1 piece/set



GX 270-000-07



GX 340-390-K18

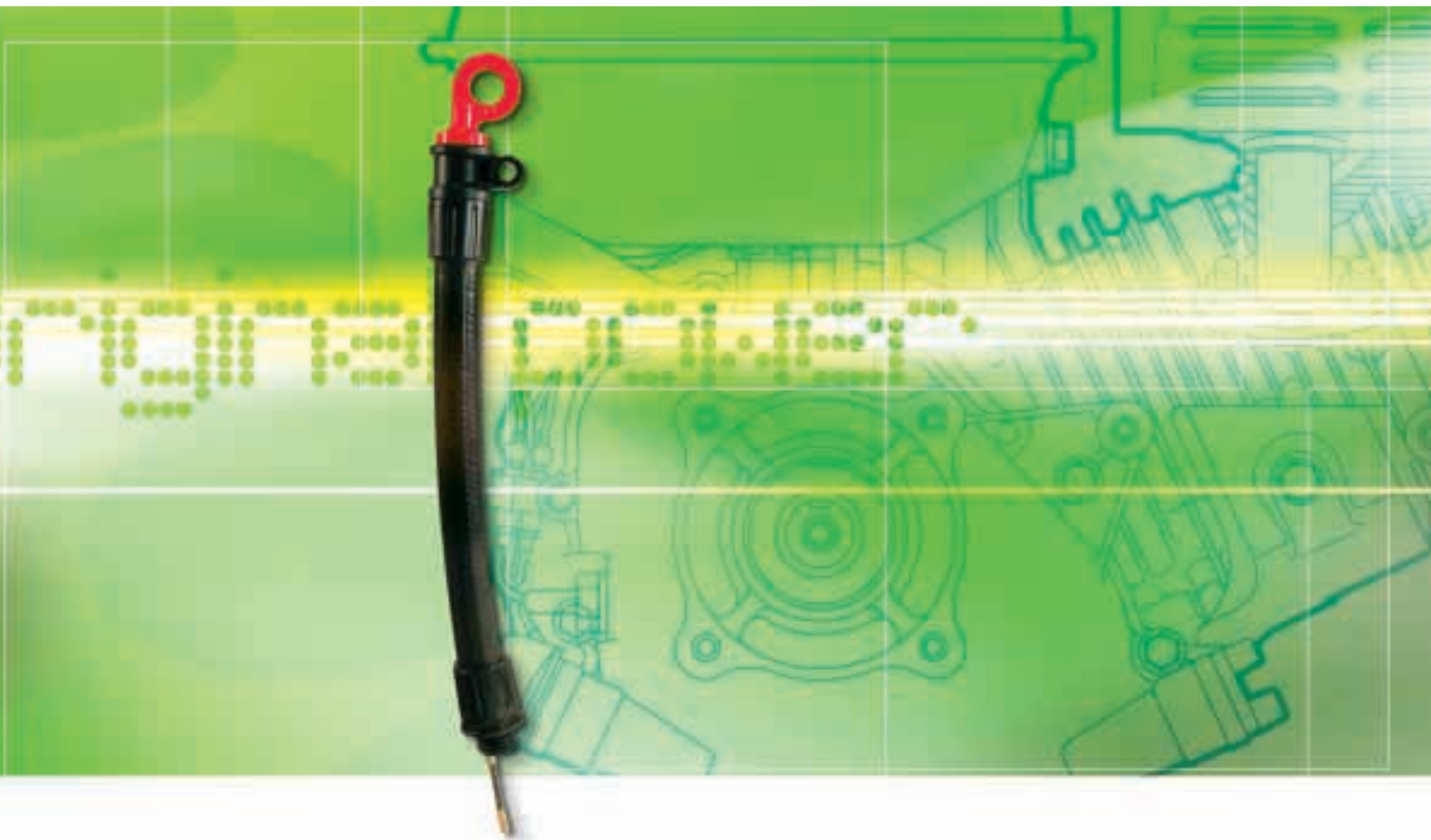

Applicable for GX 240K1, GX 270, GX 340K1, GX 390K1



Mounted on front support tank
Applicable for GX 120K1, GX 160K1, GX 200

En-guard (plastic type) no deflector

Heat protection for	Partnumber	Packing
GX 240K1, GX 270 (silent muffler) and GX 340K1, GX 390K1 (std muffler)	D6185-2F6-W400	1 piece/set

REF.	Component name	QTY
1	muffler cover comp.	1
2	rear muffler cover comp.	1
3	muffler cover base comp.	1
4	muffler cover spacer	3
5	air cleaner case collar	2
6	hex.nut 5mm	3
7	plain washer 5mm	3

REF.	Component name	QTY
8	screw washer 6x20	3
9	tapping screw 5x25	2
10	tapping screw 5x8	1
11	muffler cover stay	1
12	plate set	1
13	screw washer 5x12	1
14	spring washer	1

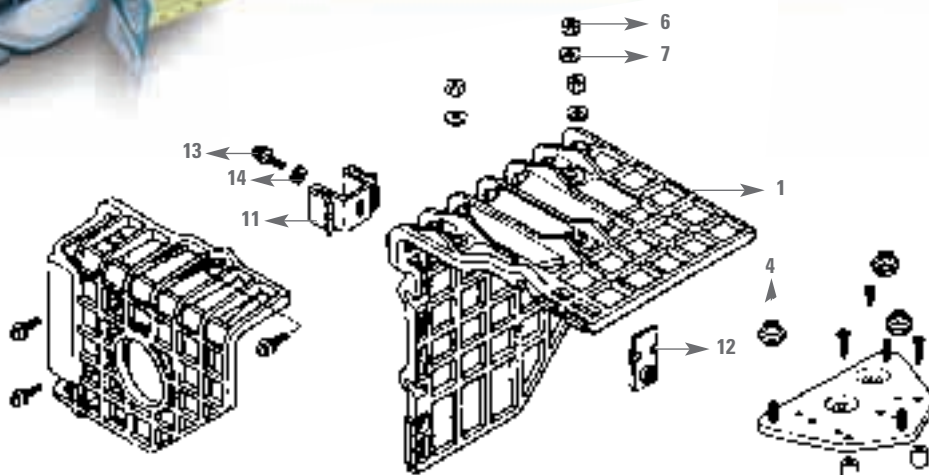

Remark tapping screw (ref 9)

Must be mounted in holes '4' mentioned on base comp.(ref 3)

En-guard (plastic type) with deflector

Heat protection and deflection of exhaust gases for	Partnumber	Packing
GX 240K1, GX 270 (silent muffler) and GX 340K1, GX 390K1 (std muffler)	06185-2FG-W500	1 piece/set

REF.	Component name	QTY
1	muffler cover comp.	1
2	rear muffler cover comp.	1
3	muffler cover base comp.	1
4	muffler cover spacer	3
5	air cleaner case collar	2
6	hex.nut 5mm	3
7	plain washer 5mm	3
8	screw washer 6x20	3

REF.	Component name	QTY
9	tapping screw 5x25	2
10	tapping screw 5x8	1
11	muffler cover stay	1
12	plate set	1
13	screw washer 5x12	1
14	spring washer	1
15	deflector	1
16	tapping screw 4x6	2

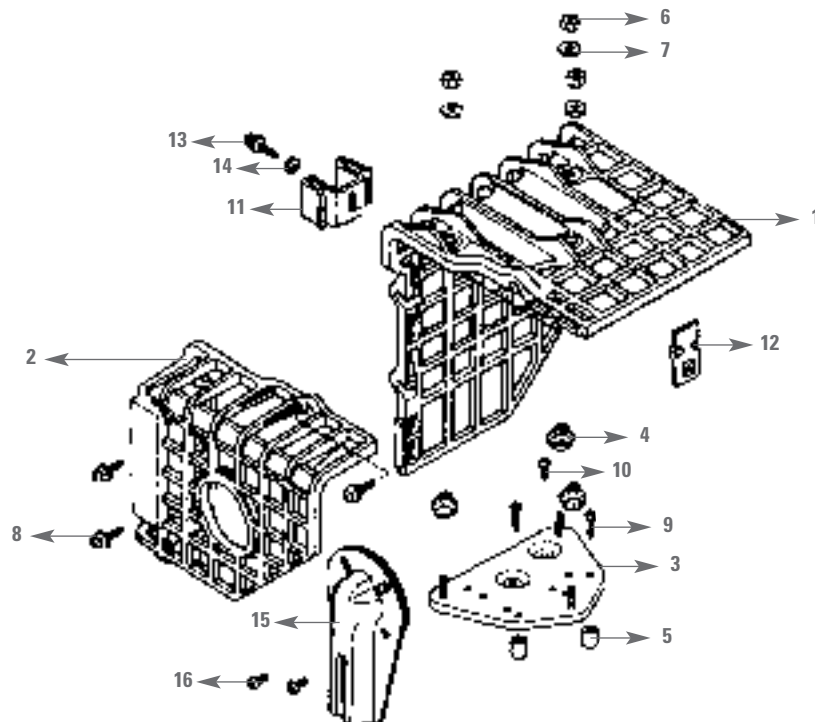

Remark tapping screw (ref 9)

Must be mounted in holes '4' mentioned on base comp.(ref 3)

En-guard (plastic type) no deflector

Heat protection for	Partnumber	Packing
GX 120K1, GX 160K1 (std and silent muffler) and GX 200 (std muffler)	D6185-ZH8-W400	1 piece/set

REF.	Component name	QTY
1	muffler cover comp.	1
2	rear muffler cover comp.	1
3	muffler cover base comp.	1
4	muffler cover spacer	3
5	air cleaner case collar	2

REF.	Component name	QTY
6	hex.nut 5mm	3
7	plain washer 5mm	3
8	screw washer 6x20	3
9	tapping screw 5x25	2
10	tapping screw 5x8	1

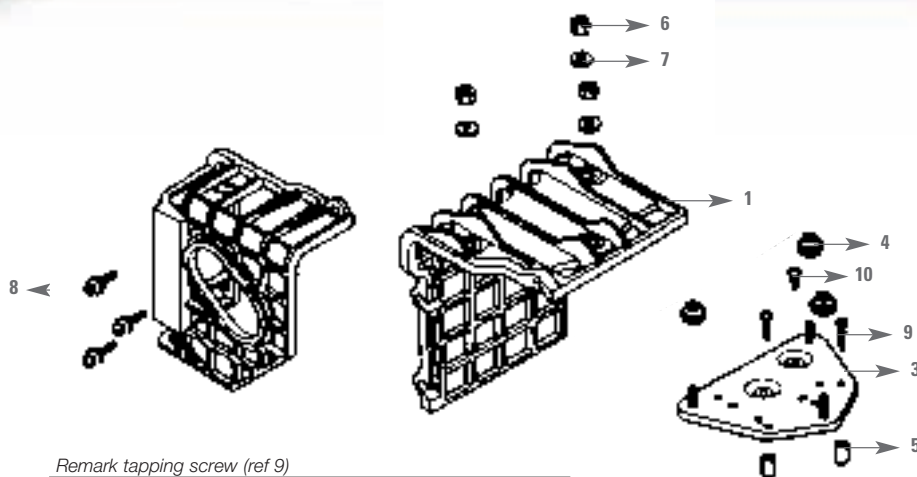
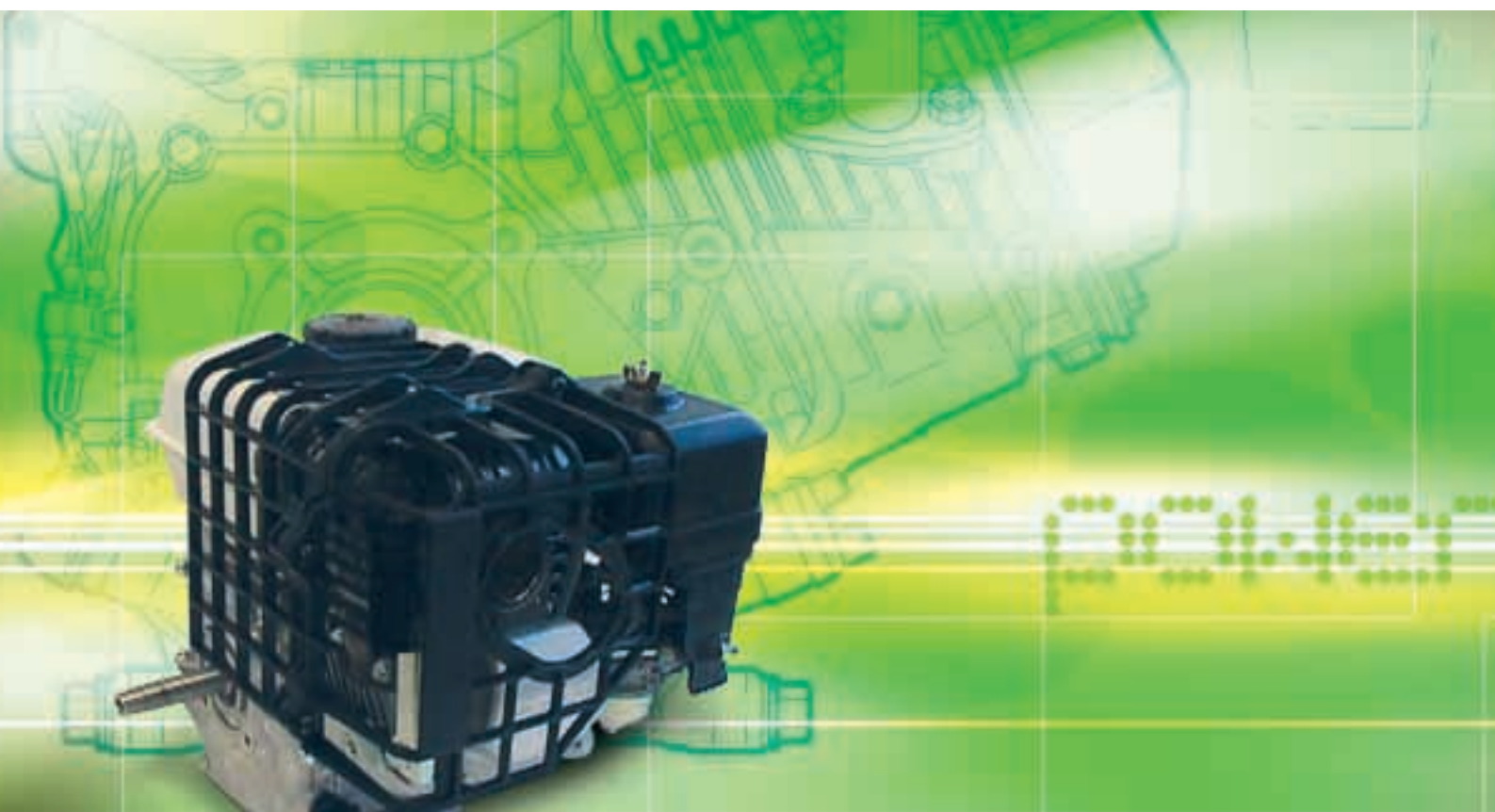

Remark tapping screw (ref 9)
Must be mounted in holes '2' mentioned on base comp.(ref 3)

En-guard (plastic type) with deflector

Heat protection and deflection of exhaust gases for	Partnumber	Packing
GX 120K1, GX 160K1 (std and silent muffler) and GX 200 (std muffler)	06185-ZH8-W500	1 piece/set

REF.	Component name	QTY
1	muffler cover comp.	1
2	rear muffler cover comp.	1
3	muffler cover base comp.	1
4	muffler cover spacer	3
5	air cleaner case collar	2
6	hex.nut 5mm	3

REF.	Component name	QTY
7	plain washer 5mm	3
8	screw washer 6x20	3
9	tapping screw 5x25	2
10	tapping screw 5x8	1
11	deflector	1
12	tapping screw 4x6	2

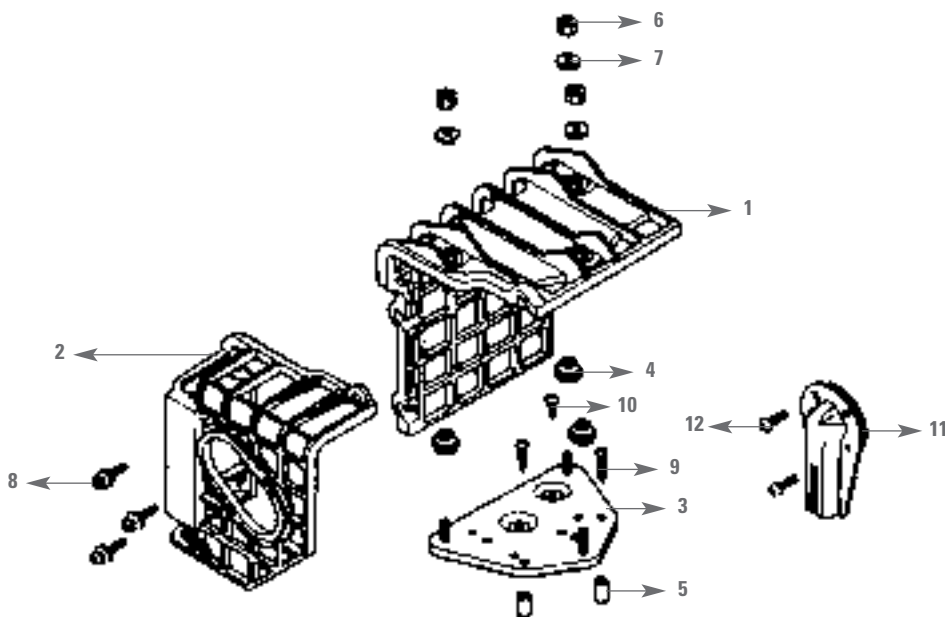

Remark tapping screw (ref 9)
Must be mounted in holes '2' mentioned on base comp.(ref 3)

En-guard (metal type) no deflector

Heat protection for	Partnumber	Packing
GX 120K1, GX 160K1 tiller (standard muffler)	06185-ZH8-W600	1 piece/set

REF.	Component name	QTY
1	en-guard	1
2	screw pan	2
3	washer ZM5	2
4	tapping screw 6,3x13	1
5	washer ZM6	1

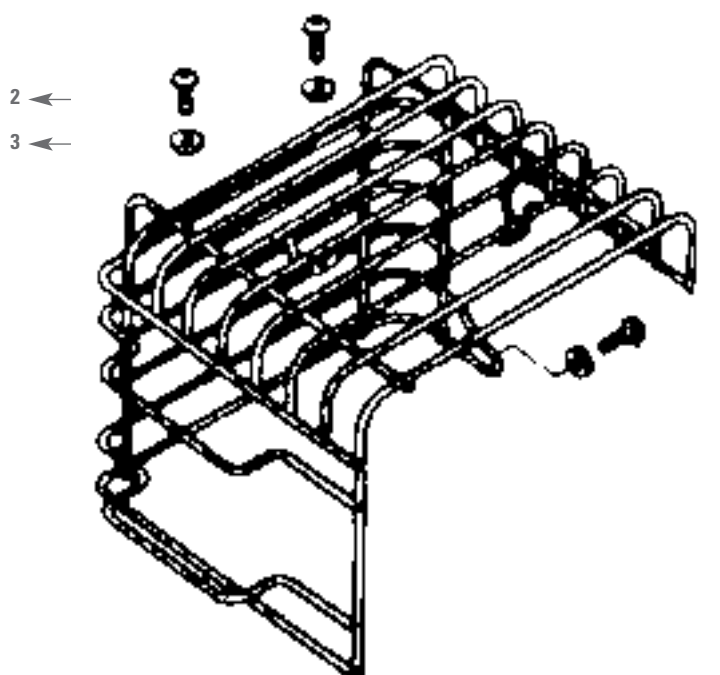
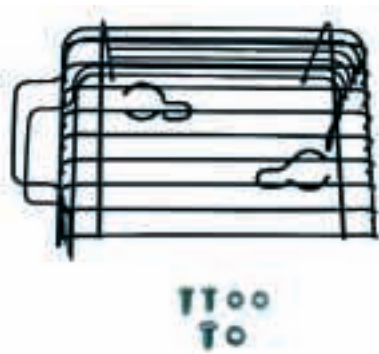

En-guard no deflector

Heat protection for	Partnumber	Packing
GX 240K1, GX 270 (std muffler)	06185-ZK9-W400	1 piece/set

REF.	Component name	QTY
1	muffler cover comp.	1
2	rear muffler cover comp.	1
3	muffler cover base comp.	1
4	muffler cover spacer	3
5	air cleaner case collar	2
6	hex.nut 5mm	3
7	plain washer 5mm	3

REF.	Component name	QTY
8	screw washer 6x20	3
9	tapping screw 5x25	2
10	tapping screw 5x8	1
11	muffler cover stay	1
12	plate set	1
13	screw washer 5x12	1
14	spring washer	1

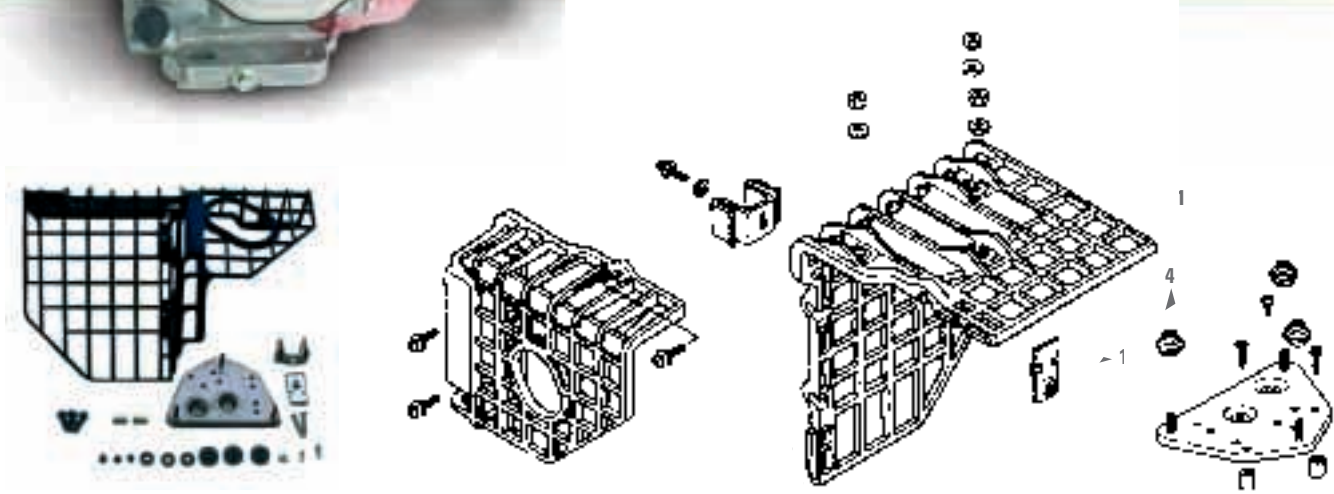
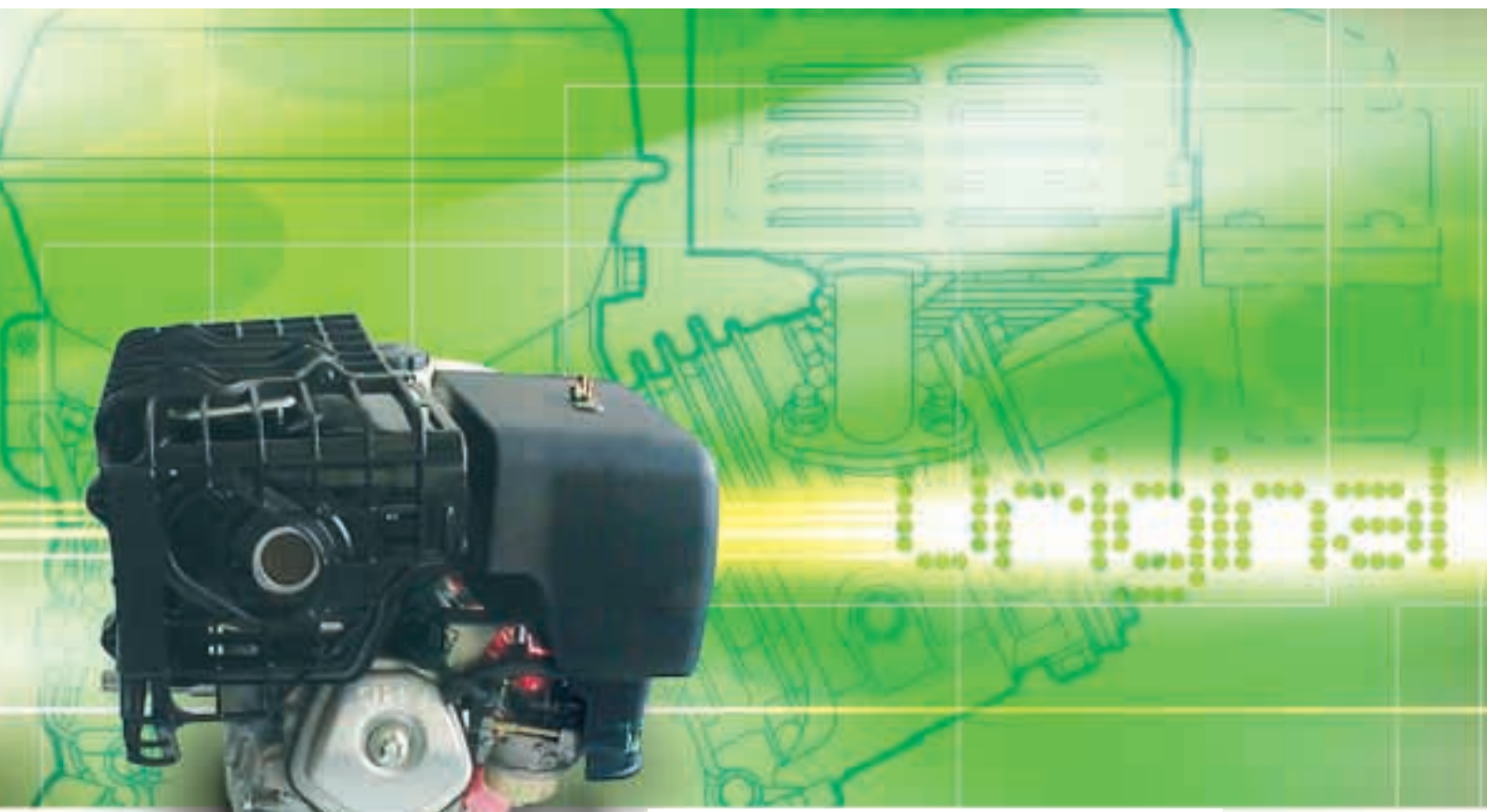

Remark tapping screw (ref 9)
Must be mounted in holes '4' mentioned on base comp.(ref 3)

En-muffler guard (plastic type) with deflector

Heat protection and deflection of exhaust gases for	Partnumber	Packing
GX 240K1, GX 270 (std muffler)	D6185-ZK9-W500	1 piece/set

REF.	Component name	QTY
1	muffler cover comp.	1
2	rear muffler cover comp.	1
3	muffler cover base comp.	1
4	muffler cover spacer	3
5	air cleaner case collar	2
6	hex.nut 5mm	3
7	plain washer 5mm	3
8	screw washer 6x20	3

REF.	Component name	QTY
9	tapping screw 5x25	2
10	tapping screw 5x8	1
11	muffler cover stay	1
12	plate set	1
13	screw washer 5x12	1
14	spring washer	1
15	deflector	1
16	tapping screw 4x6	2

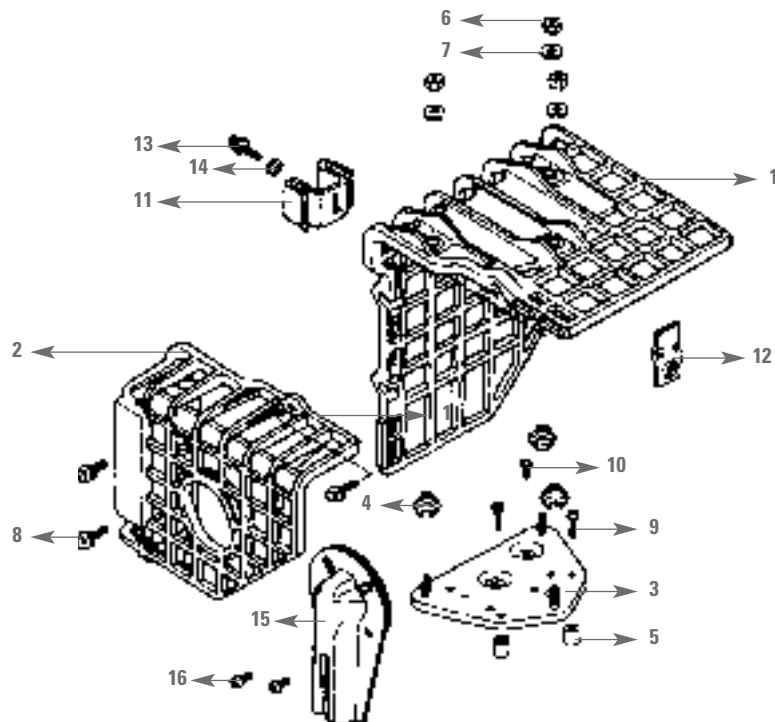

Remark tapping screw (ref 9)
 Must be mounted in holes '4' mentioned on base comp.(ref 3)

Universal muffler for v-twin engine

Engine model	Partnumber	Packing
GX(V) 610K1/620K1/670	06183-ZJ1-BOSU	1 piece/set
GCV 520/530, GXV 520/530		



Top mount muffler

Muffler for	Partnumber	Packing
GX 610K1, GX 620K1, GX 670	06183-ZJ1-BOSL	1 piece/set

REF.	Component name	QTY
1	top mount muffler	1
2	mounting bolt	4

Attention
Left = starter motor side exhaust



Top mount muffler

Muffler for	Partnumber	Packing
GX 610K1, GX 620K1, GX 670	06183-ZJ1-BOSR	1 piece/set

REF.	Component name	QTY
1	top mount muffler	1
2	mounting bolt	4

Attention
Right = oil filter side exhaust

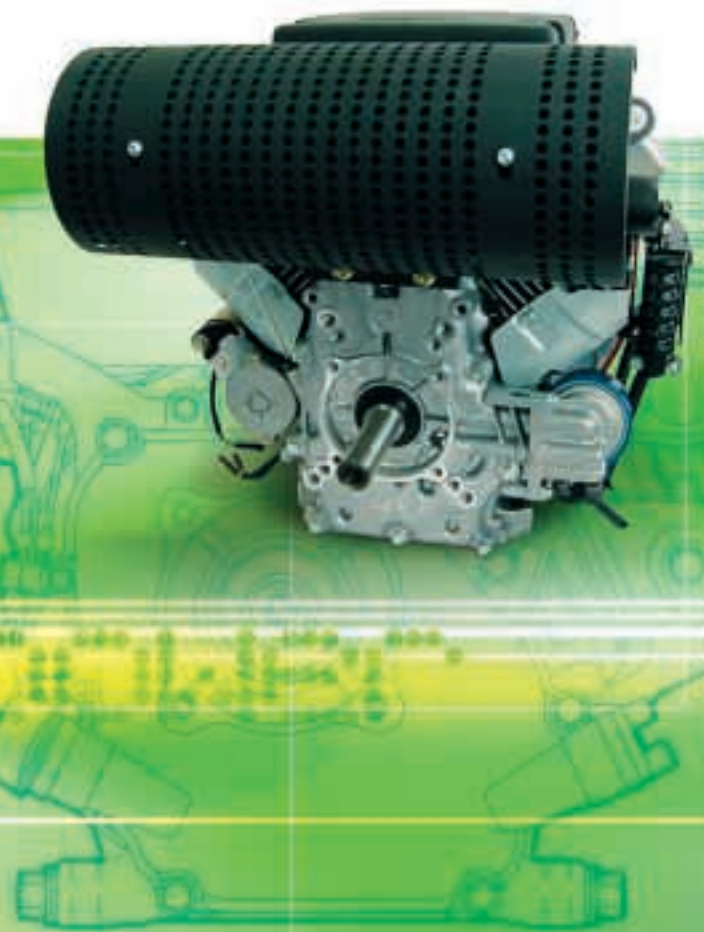
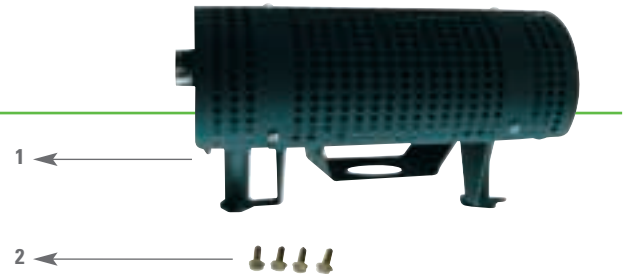

Heat shield

Heat protector plate for	Partnumber	Packing
Top mount muffler on GX 610K1, GX 620K1 GX 670 equipped with plastic fuel tank	18434-ZJ1-BOS	1 piece/set



Attention
Heat shield installation is obligatory when plastic fuel tank is mounted!

Deflector

90° deflector pipe for top mount muffler on	Partnumber	Packing
GX 610K1, GX 620K1, GX 670	18431-ZH8-B0S	1 piece/set

REF.	Component name	QTY
1	deflector	1
2	clamp	1
3	washer	2
4	nut	2

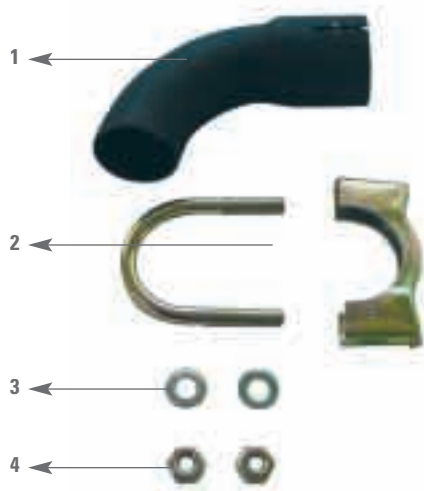

Exhaust flange

Welding flange for exhaust pipe	Partnumber	Packing
GX(V) 610/620, GX(V) 610K1, GX(V) 620K1, GX(V) 670	GX620-000001	2 pieces/set



Exhaust pipe

Exhaust pipe for	Partnumber	Packing
GCV 520/530, GXV 520/530	18331-Z0A-SET	2 pieces/set



Deflector (long type)

Deflector of exhaust gases for	Partnumber	Packing
GX 120K1/160K1/200/240K1/270/340K1/390K1	18431-ZHB-W500	1 piece/set

REF.	Component name	QTY
1	deflector	1
2	tapping screw (M4x6)	4



Deflector (short type)

Deflection of exhaust gases for	Partnumber	Packing
GX 120K1/160K1/200/240K1/270/340K1/390K1	GX20-000-00	1 piece/set

REF.	Component name	QTY
1	deflector	1
2	tapping screw (M4x6)	4



Low noise muffler

Super silent muffler for	Partnumber	Packing
GX 340K1, GX 390K1	18310-ZB8-SIL	1 piece/set

REF.	Component name	QTY
1	muffler comp.	1
2	exhaust pipe	1
3	gasket exhaust pipe	2
4	hex.bolt 8x28	2
5	flange nut 10mm	2

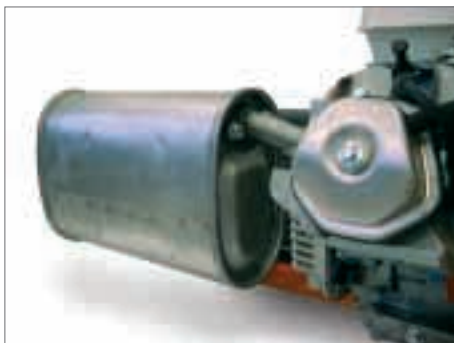
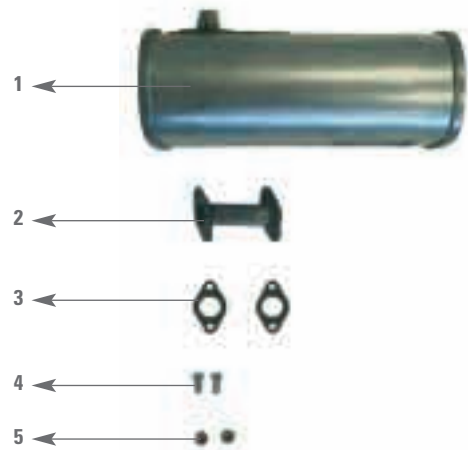

Remark

Flange nut 10mm is used as spacer to tighten the exhaust pipe onto the cylinder head.

11 liter fuel tank

Partnumber	Packing
17500-6X1-11L	1 piece/set

REF.	Component name	QTY
1	fuel tank comp.	1
2	fuel filler cap comp.	1
3	fuel meter assy.	1
4	flat screw 5x10	2
5	fuel cock assy.	1

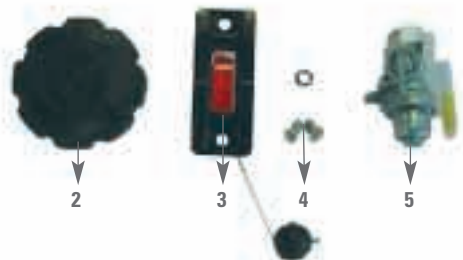

18 liter fuel tank

Partnumber	Packing
17500-6X1-18L	1 piece/set

REF.	Component name	QTY
1	fuel tank comp.	1
2	fuel filler cap comp.	1
3	fuel meter assy.	1
4	flat screw 5x10	2
5	fuel cock assy.	1

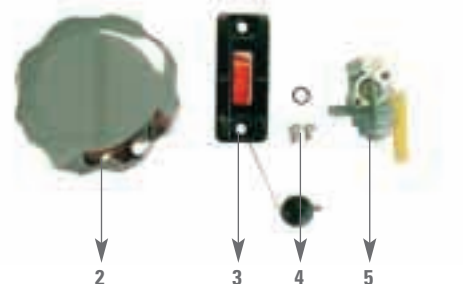

ENG IMPORTANT

Every effort has been made to ensure accuracy and comprehensiveness of the information included in this catalogue. However, Honda Europe cannot be held responsible for errors or omissions and for alterations occurred after release for printing.

FR IMPORTANT

Tous les efforts ont été faits pour assurer l'exactitude et l'exhaustivité de l'information contenue dans ce catalogue. Néanmoins, Honda Europe ne peut porter la responsabilité d'erreurs ou d'annulations et de modifications intervenues après l'autorisation d'impression.

D WICHTIG

Die Ihnen vorliegende Information wurde nach bestem Wissen und Gewissen zusammengestellt. Für Irrtümer oder Änderungen und den daraus resultierenden Schäden kann keine Gewähr übernommen werden.

NL BELANGRIJK

Al het mogelijke werd gedaan om de juistheid en volledigheid van de geboden informatie in deze catalogus te garanderen. Honda Europe kan evenwel niet aansprakelijk worden gesteld voor fouten of weglatingen en voor wijzigingen die na de vrijgave voor de druk zijn voorgekomen.

E IMPORTANTE

Se han realizado todos los esfuerzos posibles para garantizar la fiabilidad de este catálogo. No obstante, Honda Europa no se responsabiliza de los errores, omisiones o alteraciones que puedan producirse tras su impresión.

I IMPORTANTE

Tutti gli sforzi sono stati fatti per assicurare l'esattezza e la completezza delle informazioni contenute in questo catalogo. In ogni caso, la società Honda Europe non potrà essere ritenuta responsabile per errori, modifiche o annullamenti verificatisi dopo l'autorizzazione alla stampa.

P IMPORTANTE

Todos os esforços foram feitos para assegurar a exactidão da informação contida neste catálogo. No entanto, a Honda Europe não se responsabiliza por qualquer tipo de erro ou anulação após dada a autorização para impressão.

FI TÄRKEÄÄ

Olemme pyrkineet tekemään tämän luettelon niin täsmälliseksi ja kattavaksi kuin mahdollista. Honda Europe ei kuitenkaan vastaa painatuksen jälkeen tapahtuneista muutoksista.

DK VIGTIGT

Der er lagt stor vægt på at gøre informationerne i dette katalog så korrekte og omfattende som muligt. Honda Europe kan dog ikke stilles til ansvar for fejl eller udeladelser samt ændringer der er sket efter kataloget er frigivet til trykning.

N VIKTIG

Det er lagt stor vekt på å gjøre informasjonen i denne katalogen så korrekt og omfattende som mulig. Honda reserverer seg fra eventuelle trykkfeil samt endringer som har skjedd etter publisering.

S VIKTIGT

Stor vikt har lagts på att göra informationen i denna katalog så korrekt och omfattande som möjligt. Honda reserverar sig för feltryck samt ändringar som gjorts efter att katalogen gått i tryck.

CZ DŮLEŽITÉ

Byla věnována velká pozornost přesnosti a rozsahu informací obsažených v tomto katalogu. Nicméně, Honda Europe nenesse odpovědnost za chyby nebo opomenutí a za změny které nastanou po vytištění.

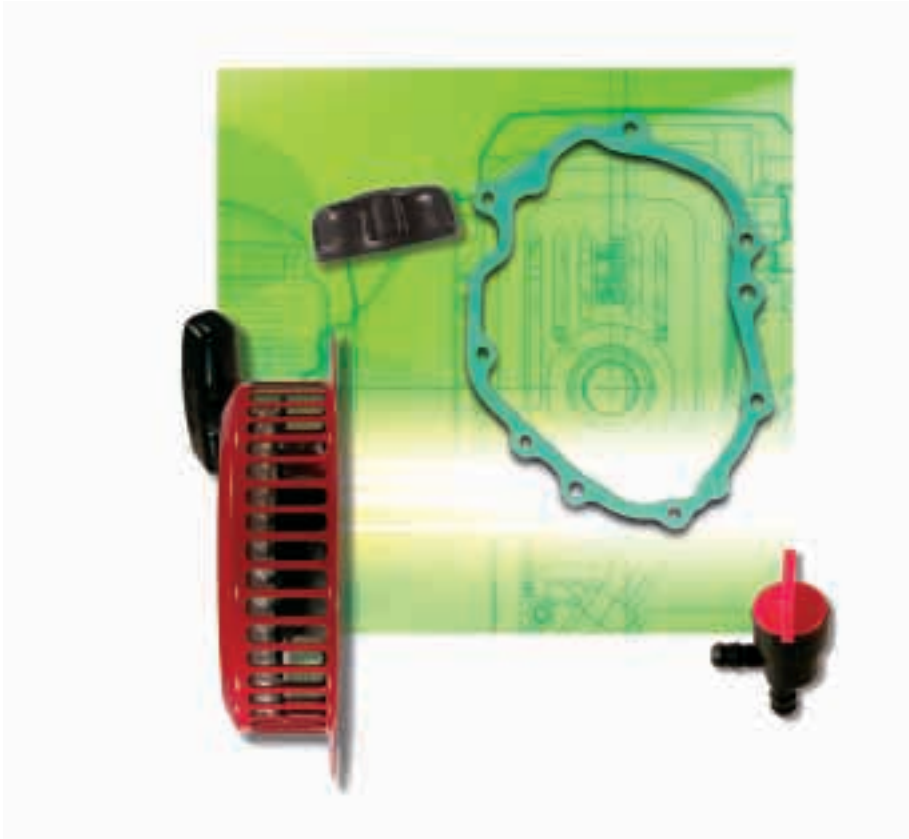

Honda Europe NV
Langerbruggestraat 104
B-9000 Gent