

BOMAG

FAYAT GROUP

Operating Instruction Maintenance Instruction

Original Operating Instructions

BVP 10/30

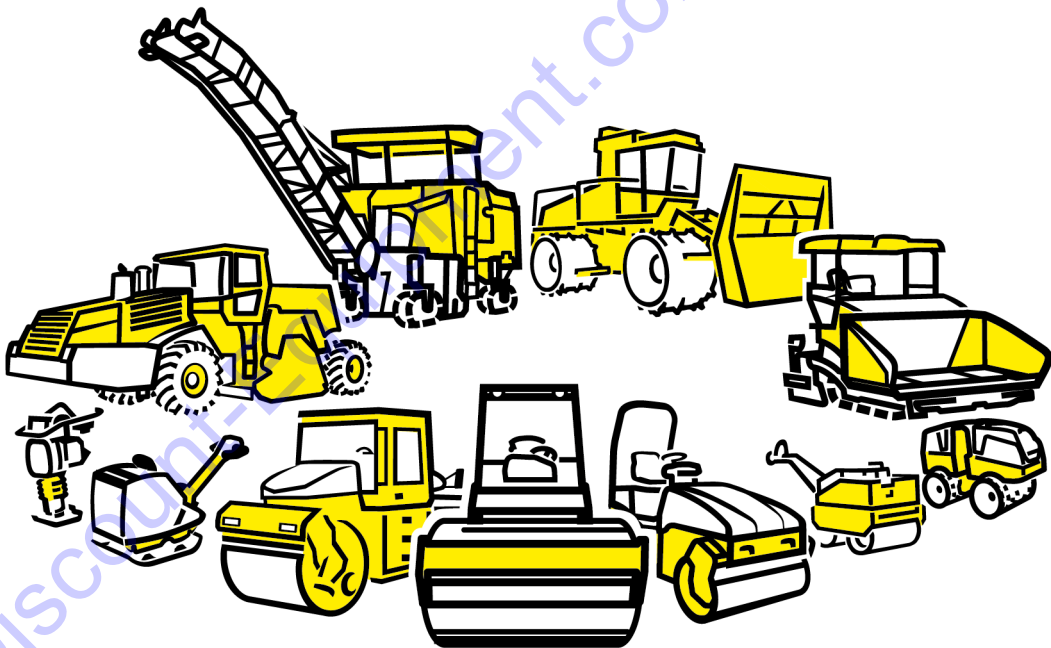

S/N 861 834 19 1001> / S/N 861 834 35 1001>

Single direction vibratory plate



www.discount-equipment.com

PARTS FINDER

**Search Website
by Part Number**



**Search Manual
Library For Parts
Manual & Lookup Part
Numbers – Purchase
or Request Quote**

Search Manuals

Enter your information to help us find the right parts manual for your equipment.

* Brand:

* Model:

* Serial:

* Part Number:

SEARCH

**Can't Find Part or
Manual? Request Help
by Manufacturer,
Model & Description**

Parts Order Form

Please fill in the following information to help us find the right part for your equipment.

Manufacturer:	<input type="text"/>
Model:	<input type="text"/>
Description:	<input type="text"/>
Part Number:	<input type="text"/>
Quantity:	<input type="text"/>
Notes:	<input type="text"/>

Submit

Discount-Equipment.com is your online resource for quality parts & equipment.

Florida: **561-964-4949** Outside Florida TOLL FREE: **877-690-3101**

Need parts?

Click on this link: <http://www.discount-equipment.com/category/5443-parts/> and choose one of the options to help get the right parts and equipment you are looking for. Please have the machine model and serial number available in order to help us get you the correct parts. If you don't find the part on the website or on one of the online manuals, please fill out the request form and one of our experienced staff members will get back to you with a quote for the right part that your machine needs.

We sell worldwide for the brands: Genie, Terex, JLG, MultiQuip, Mikasa, Essick, Whiteman, Mayco, Toro Stone, Diamond Products, Generac Magnum, Airman, Haulotte, Barreto, Power Blanket, Nifty Lift, Atlas Copco, Chicago Pneumatic, Allmand, Miller Curber, Skyjack, Lull, Skytrak, Tsurumi, Husquvarna Target, Stow, Wacker, Sakai, Mi-T-M, Sullair, Basic, Dynapac, MBW, Weber, Bartell, Bennar Newman, Haulotte, Ditch Runner, Menegotti, Morrison, Contec, Buddy, Crown, Edco, Wyco, Bomag, Laymor, EZ Trench, Bil-Jax, F.S. Curtis, Gehl Pavers, Heli, Honda, ICS/PowerGrit, IHI, Partner, Imer, Clipper, MMD, Koshin, Rice, CH&E, General Equipment, Amida, Coleman, NAC, Gradall, Square Shooter, Kent, Stanley, Tamco, Toku, Hatz, Kohler, Robin, Wisconsin, Northrock, Oztec, Toker TK, Rol-Air, APT, Wylie, Ingersoll Rand / Doosan, Innovatech, Con X, Ammann, Mecalac, Makinex, Smith Surface Prep, Small Line, Wanco, Yanmar

⚠️ WARNING: Breathing diesel engine exhaust exposes you to chemicals known to the State of California to cause cancer and birth defects or other reproductive harm.

- Always start and operate the engine in a well-ventilated area.
- If in an enclosed area, vent the exhaust to the outside.
- Do not modify or tamper with the exhaust system.
- Do not idle the engine except as necessary.

For more information go to www.P65warnings.ca.gov/diesel.

⚠️ WARNING: Crude oil, gasoline, diesel fuel and other petroleum products can expose you to chemicals including toluene and benzene, which are known to the State of California to cause cancer and birth defects or other reproductive harm.

These exposures can occur in and around oil fields, refineries, chemical plants, transport and storage operations such as pipelines, marine terminals, tank trucks and other facilities and equipment.

For more information go to www.P65Warnings.ca.gov/petroleum.

Table of contents

1	Introduction	7
	1.1 Foreword	8
	1.2 Machine type plate and engine type plate	10
2	Technical data	11
	2.1 Noise and vibration data	14
	2.1.1 Noise data.....	14
	2.1.2 Vibration data.....	14
3	Concerning your safety	15
	3.1 Basic prerequisites	16
	3.1.1 General.....	16
	3.1.2 Explanation of signal words used.....	16
	3.1.3 Personal protective equipment.....	17
	3.1.4 Intended use.....	18
	3.1.5 Improper use.....	18
	3.2 Definition of responsible persons	20
	3.2.1 Operating company.....	20
	3.2.2 Expert / qualified person.....	20
	3.2.3 Driver / operator.....	20
	3.3 Basic safety regulations for safe operation	22
	3.3.1 Remaining dangers, remaining risks.....	22
	3.3.2 Regular safety inspections.....	22
	3.3.3 Modifications and alterations to the machine.....	22
	3.3.4 Damage, defects, misuse of safety devices.....	22
	3.3.5 Notes on operating the machine safely.....	23
	3.4 Handling fuels and lubricants	25
	3.4.1 Preliminary remarks.....	25
	3.4.2 Safety regulations and environmental protection regulations for handling oil.....	26
	3.4.3 Safety regulations and environmental protection regulations for handling gasoline.....	27
	3.4.4 Safety regulations and environmental protection regulations for handling fuel stabiliser.....	28
	3.5 Loading / transporting the machine	29
	3.6 Start-up procedure	30
	3.6.1 Prior to starting up.....	30
	3.6.2 Starting the engine.....	30
	3.7 Operation	31
	3.7.1 Persons in the danger zone.....	31
	3.7.2 Operation.....	31
	3.7.3 Parking the machine.....	31
	3.8 Refuelling	33
	3.9 Maintenance work	34
	3.9.1 Preliminary remarks.....	34
	3.9.2 Working on the engine.....	34
	3.9.3 Cleaning work.....	34
	3.9.4 After maintenance work.....	34
	3.10 Repair	35

Table of contents

3.11	Signage.....	36
4	Machine description.....	41
4.1	Function and design.....	42
4.2	Indicators and control elements.....	45
4.2.1	Starter switch.....	45
4.2.2	Recoil starter.....	46
4.2.3	Throttle lever.....	46
4.2.4	Fuel valve.....	46
4.2.5	Choke lever.....	47
5	Checks prior to start up.....	49
5.1	Notes on safety.....	50
5.2	Visual inspections and function tests.....	51
5.3	Checking the engine oil level.....	53
5.4	Checking the fuel level, topping up fuel.....	54
6	Operation.....	55
6.1	Initial start-up.....	56
6.2	Guide handle.....	57
6.2.1	Mounting the guide handle.....	58
6.2.2	Removing the guide handle.....	60
6.3	Plastic mat.....	62
6.3.1	Mount the plastic mat.....	63
6.3.2	Removing the plastic mat.....	65
6.4	Starting the engine.....	67
6.5	Operation.....	71
6.6	Parking the machine in secured condition.....	74
7	Loading / transporting the machine.....	77
7.1	Preliminary remarks and safety notes.....	78
7.2	Loading with lifting tackle.....	79
7.3	Loading without lifting tackle.....	80
7.4	Lashing the machine to the transport vehicle.....	81
7.5	After transport.....	83
8	Maintenance.....	85
8.1	Preliminary remarks and safety notes.....	86
8.2	Fuels and lubricants.....	87
8.2.1	Engine oil.....	87
8.2.2	Fuel.....	87
8.3	List of fuels and lubricants.....	89
8.4	Maintenance Table.....	90
8.5	Running-in instructions.....	91
8.5.1	General.....	91
8.5.2	After 25 operating hours.....	91
8.6	Monthly.....	92
8.6.1	Air filter maintenance.....	92
8.7	Semi-annually.....	93
8.7.1	Changing the engine oil.....	93

8.8	Annually	94
8.8.1	Checking, adjusting the valve clearance.....	94
8.8.2	Replacing the spark plug.....	98
8.8.3	Replacing the fuel strainer.....	99
8.8.4	Replacing the starter rope.....	100
8.8.5	Replacing the air filter.....	102
8.8.6	Replacing the V-belt.....	103
8.9	As required	106
8.9.1	Cleaning the cooling fins and the cooling air intake openings.....	106
8.9.2	Cleaning the machine.....	107
8.9.3	Cleaning, checking the spark plug, replacing if necessary.....	108
8.9.4	Checking, adjusting the engine speed.....	110
8.9.5	Measures for longer shut-down periods.....	112
9	Troubleshooting	115
9.1	Preliminary remarks	116
9.2	Engine malfunctions	117
9.3	What to do if the engine has flooded	118
10	Disposal	123
10.1	Final shut-down of machine	124
11	List of special tools	125
12	Terminology	127

Go to Discount-Equipment.com to order your parts

1.1 Foreword

BOMAG manufactures machines for earth, asphalt and refuse compaction, stabilizers/recyclers as well as planers and pavers.

BOMAG's vast experience in connection with state-of-the-art production and testing methods, such as lifetime tests of all important components and highest quality demands guarantee maximum reliability of your machine.

These operating and maintenance instructions are part of your machine.

They provide necessary information to operate your machine safely and properly.

They also contain information on required operating, maintenance and repair measures.

Carefully read the operating and maintenance instructions before taking your machine into operation.

Please observe the safety regulations strictly and follow all instructions to ensure safe operation.

If you are not yet acquainted with the controls and indicating elements on this machine, you should thoroughly read the corresponding chapter ↪ *Chapter 4.2 „Indicators and control elements“ on page 45.*

The description of the individual operating steps including the notes on safety to be followed can be found in chapter “Operation” ↪ *Chapter 6 „Operation“ on page 55.*

Before every start up, carry out all required visual inspections and function tests ↪ *Chapter 5 „Checks prior to start up“ on page 49.*

Ensure the compliance with the specified operating, maintenance and repair measures to maintain the functional safety of your machine.

A description of all necessary maintenance work, maintenance intervals as well as information on fuels and lubricants can be found in the chapter “Maintenance” ↪ *Chapter 8 „Maintenance“ on page 85.*

Do not service or repair your machine by yourself to avoid harming persons or damaging material or environment.

The machine must only be serviced and repaired by qualified and authorized personnel.

Contact our Customer Service to carry out the required maintenance work or necessary repairs.

In case of operating errors, inadequate maintenance or the use of unapproved fuels and lubricants all warranty claims will become null and void.

For your own personal safety you should only use original parts from BOMAG.

For your machine we offer service kits to make maintenance easier.

In the course of technical development we reserve the right for technical modifications without prior notification.

These operating and maintenance instructions are also available in other languages.

Apart from that, you can also order the spare parts catalogue against the serial number of your machine.

The above notes do not constitute an extension of the warranty and liability conditions specified in the general sales and delivery conditions of BOMAG GmbH.

We wish you successful work with your BOMAG machine.

Go to Discount-Equipment.com to order your parts

1.2 Machine type plate and engine type plate

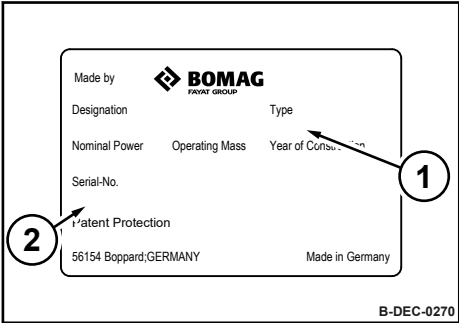

Fig. 1

Please enter here:	
Machine type (1):	
Serial number (2):	

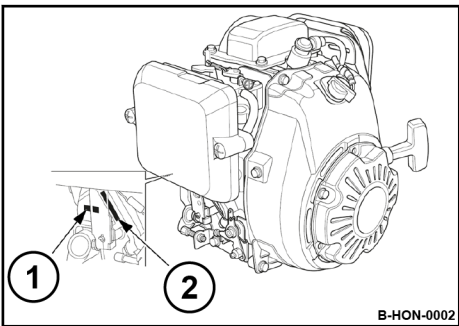

Fig. 2: Engine type and engine number

Please enter here:	
Engine type (1):	
Engine number (2):	

Go to Discount-Equipment.com to order your parts

Go to Discount-Equipment.com to order your parts

Technical data

Dimensions

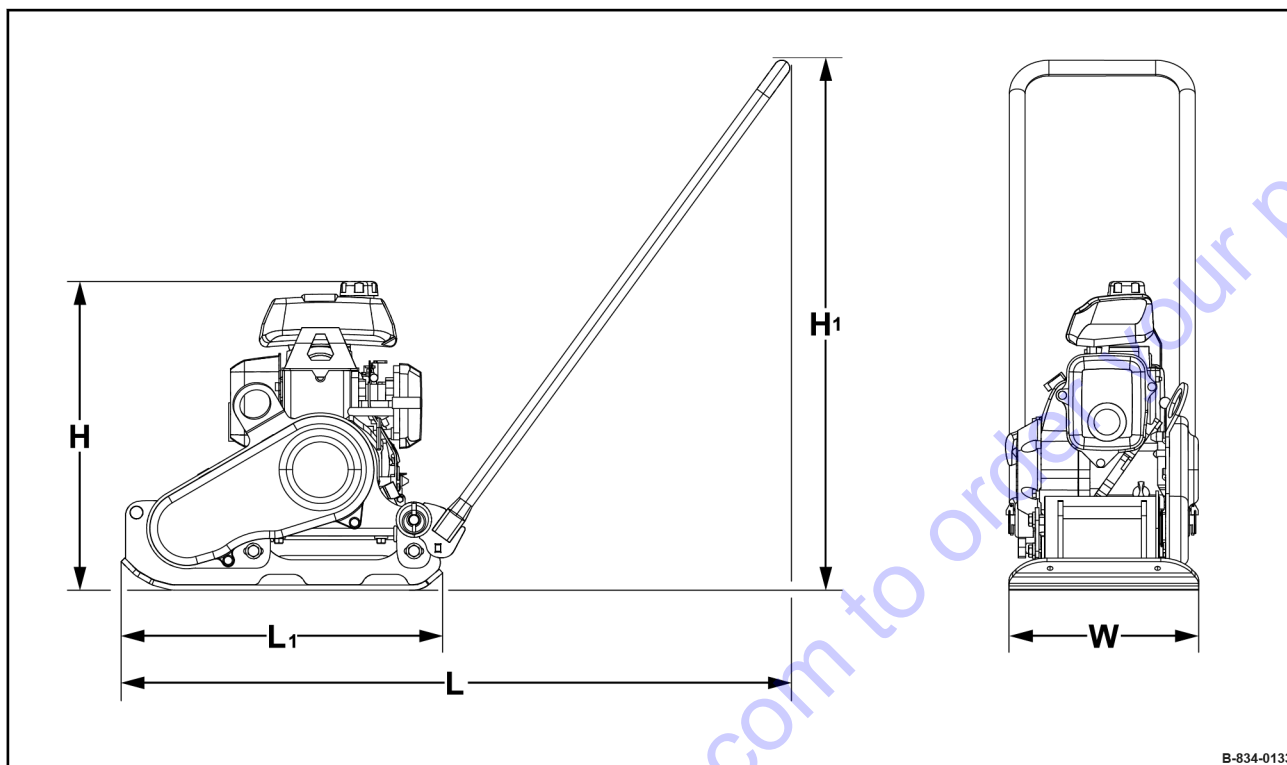

B-834-0133

Fig. 3

H	H ₁	L	L ₁	W
489	840	1058	509	300
(19.3)	(33.1)	(41.7)	(20.0)	(11.8)

Dimensions in millimetres

(Dimensions in inch)

Weights			
Operating weight (CECE)		47	kg
		(104)	(lbs)
Basic weight		46	kg
		(101)	(lbs)

Technical data

Travel characteristics		
Max. working speed	25 (82)	m/min (ft/min)
Max. gradability (depending on soil)	30	%
Max. cross slope	36	%

Drive		
Engine manufacturer	Honda	
Type	GX 100	
Cooling	Air	
Number of cylinders	1	
Rated power SAE J 1349	2.1 (2.8)	kW (hp)
Rated speed	3600	min ⁻¹
Drive system	mechanical	

Exciter system		
Frequency	100 (6000)	Hz (vpm)
Centrifugal force	10 (2248)	kN (lbf)
Amplitude	1.34 (0.053)	mm (in)

Filling capacities		
Fuel (gasoline)	0.8 (0.2)	l (gal us)

2.1 Noise and vibration data

The following noise and vibration data were determined in accordance with the following guidelines under equipment specific conditions and by using harmonized standards:

- EU Machine Directive edition 2006/42/EU
- Noise Emission Directive 2000/14/EU, Noise Protection Directive 2003/10/EU
- Vibration Protection Directive 2002/44/EU

During operation these values may vary because of the prevailing operating conditions.

2.1.1 Noise data

Sound pressure level at the operator's stand

$L_{pA} = 91$ dB(A), determined acc. to ISO 11201 and EN 500.



WARNING!

Loss of hearing caused by too high noise burdens!

- Wear your personal protective equipment (ear protection).

Guaranteed sound power level

$L_{WA} = 101$ dB(A), determined acc. to ISO 3744 and EN 500

2.1.2 Vibration data

Hand-arm vibration

Vector total of the weighted effective acceleration in three orthogonal directions:

Total vibration value $a_{hv} = 3.7$ m/s² on crushed rock determined acc. to ISO 5349 and EN 500.

Associated uncertainty $K = 0.3$ m/s², determined acc. to EN 12096.

Observe the daily vibration load (work safety acc. to 2002/44/EC).

Hand-arm vibration with comfort guide handle (optional equipment)

Vector total of the weighted effective acceleration in three orthogonal directions:

Total vibration value $a_{hv} \leq 2.5$ m/s² on crushed rock determined acc. to ISO 5349 and EN 500.

Associated uncertainty $K = 0.2$ m/s², determined acc. to EN 12096.

Observe the daily vibration load (work safety acc. to 2002/44/EC).

Go to Discount-Equipment.com to order your parts

3.1 Basic prerequisites

3.1.1 General

This machine has been built in compliance with the latest technical standard and complies with the applicable regulations and technical rules.

However, dangers for persons and property may arise from this machine, if:

- it is used for purposes other than the ones it is intended for,
- it is operated by untrained personnel,
- it is changed or converted in an unprofessional way,
- the safety instructions are not observed.

Each person involved in the operation, maintenance and repair of the machine must therefore read and comply with these safety regulations. If necessary, the operating company must obtain the relevant signatures as confirmation.

Furthermore, the following obviously also applies:

- applicable accident prevention instructions,
- generally accepted safety and road traffic regulations,
- country/state specific safety regulations.

It is the duty of the operator to be acquainted with the safety regulations and to apply these accordingly. This also applies for local regulations and regulations concerning different types of handling activities. Should the recommendations in these instructions be different from the regulations valid in your country, you must comply with the safety regulations valid in your country.

3.1.2 Explanation of signal words used:



DANGER!

Danger to life if failing to comply!

Sections marked accordingly indicate an extremely dangerous situation that could lead to fatal or severe injuries, if this warning is disregarded.



WARNING!

Danger to life or danger of severe injuries if failing to comply!

Sections marked accordingly indicate a dangerous situation that could lead to fatal or severe injuries, if this warning is disregarded.

Concerning your safety – Basic prerequisites



CAUTION!

Danger of injury if failing to comply!

Sections marked accordingly indicate a dangerous situation that could lead to fatal or severe injuries, if this warning is disregarded.



NOTICE!

Danger of material damage if failing to comply!

Sections marked accordingly indicate possible dangers for machines or components.



Sections marked accordingly indicate technical information or notes on using the machine or its components.



ENVIRONMENT!

Environmental damage if failing to comply!





Paragraphs marked accordingly indicate practices for safe and environment-friendly disposal of fuels and lubricants as well as replacement parts.

3.1.3 Personal protective equipment

Depending on the work to be carried out, personal protective equipment is required (to be provided by the operating company):

	Working clothes	Tight fitting working clothes with low tear resistance, tight sleeves and without any projecting parts protect against being caught by moving components.
	Safety shoes	To protect against heavy falling parts and slipping on slippery ground.
	Protective gloves	To protect the hands against excoriation, punctures or deep injuries, against irritating and caustic substances as well as against burns.

Concerning your safety – Basic prerequisites

	Safety goggles	To protect the eyes against airborne particles and squirting fluids.
	Face protection	To protect the face against airborne particles and squirting fluids.
	Hard hat	To protect the head against falling parts and to protect against injuries.
	Hearing protection	To protect hearing against excessive noise.
	Respiratory protection	To protect respiratory tracts against substances or particles.

3.1.4 Intended use

This machine must only be used for:

- Compaction of all types of soils
- Repair work on all types of soil
- Paving of walkways
- Work in trenches
- Underfilling and compaction of hard shoulders

Intended use also includes compliance with the specified operating, maintenance and repair measures.

3.1.5 Improper use

Dangers may arise from the machine when it is used for purposes other than the one it is intended for.

Any danger caused by improper use is the sole responsibility of the operating company or driver/operator, the manufacturer cannot be made liable.

Concerning your safety – Basic prerequisites

Examples for improper use are:

- dragging the machine along as a measure of transportation
- throwing the machine off the transport vehicle
- attaching an additional weight to the machine

It is not permitted to stand on the machine while working.

Lifting tackle must be removed before starting work.

Starting and operating the machine in explosive environments and in underground mining is prohibited.

The lifting and lashing points specified in these instructions must be used. It is prohibited to use other lifting and lashing points (e.g. guide handle, steering rod).

Go to Discount-Equipment.com to order your parts

3.2 Definition of responsible persons

3.2.1 Operating company

The operating company is the natural or juridical person who uses the machine or in who's name the machine is used.

The operating company must make sure that the machine is only used for the purpose it is intended for and in strict compliance with the safety regulations mentioned in these operating and maintenance instructions.

The operating company must determine and assess the danger in its company. It must then take appropriate action to ensure health and safety at work for its employees and point out any remaining dangers.

The operating company must determine whether there are special operational hazards such as a toxic atmosphere or limiting soil conditions. Such conditions require special, additional measures to remove or reduce the hazard.

The operating company must make sure that all users read and understand the information concerning safety.

The operating company is responsible for the planning and professional execution of regular safety inspections.

3.2.2 Expert / qualified person

An expert / qualified person is a person who, based on his/her professional education and experience, has profound knowledge in the field of construction equipment and the machine in question in particular.

This person is acquainted with the applicable governmental industrial safety regulations, accident prevention instructions, guidelines and generally acknowledged technical rules and regulations (standards, directives, technical rules of other member states of the European Union or other contractual states concerning the agreement about the European Economic Area) in as far as is necessary to be able to judge the safe condition of this machine.

3.2.3 Driver / operator

This machine must only be operated by trained, instructed persons entrusted by the operating company aged 18 or more.

Observe your local laws and regulations.

Rights, obligations and rules of conduct for driver or operator:

The driver or operator must:

- be instructed about his rights and obligations,
- wear protective equipment as appropriate for the application,
- have read and understood the operating instructions,

Concerning your safety – Definition of responsible persons

- have made himself familiar with the operation of the machine,
- be physically and psychologically able to drive and operate the machine.

Persons under the influence of alcohol, medication or drugs are not allowed to operate, service or repair the machine.

Maintenance and repair work requires specific knowledge and must therefore only be performed by trained specialists.

Go to Discount-Equipment.com to order your parts

3.3 Basic safety regulations for safe operation

3.3.1 Remaining dangers, remaining risks

Despite careful work and compliance with standards and regulations it cannot be ruled out that further dangers may arise when working with and handling the machine.

Both the machine as well as all other system components comply with the currently valid safety regulations. Nevertheless, remaining risks cannot be ruled out completely, even when using the machine for the purpose it is intended for and following all information given in the operating instructions.

A remaining risk can also not be excluded beyond the actual danger zone of the machine. Persons remaining in this area must pay particular attention to the machine, so that they can react immediately in case of a possible malfunction, an incident or failure etc.

All persons remaining in the area of the machine must be informed about the dangers that arise from the operation of the machine.

3.3.2 Regular safety inspections

Have the machine inspected by an expert / qualified person as required for the conditions the machine is working under, but at least once every year.

3.3.3 Modifications and alterations to the machine

Unauthorized changes to the machine are prohibited for safety reasons.

Original parts and accessories have been specially designed for this machine.

We wish to make explicitly clear that we have not tested or approved any parts or accessories not supplied by us.

The installation and/or use of such products may have an adverse effect on the active and/or passive safety.

3.3.4 Damage, defects, misuse of safety devices

Machines which are not safe to operate or in traffic must be immediately taken out of service and shall not be used, until these deficiencies have been properly rectified.

Safety installations and switches must neither be removed nor must they be made ineffective.

3.3.5 Notes on operating the machine safely

Exhaust fumes contain toxic substances and can damage your health, cause unconsciousness or even death.

- Do not inhale exhaust gases.
- Avoid operation in closed or partly closed rooms, or ensure adequate ventilation when working in trenches.

Hand-arm vibrations can cause health problems such as damage to bones or joints, circulatory or neurological disorders.

- Observe the daily vibration load (work safety acc. to 2002/44/EC).
- If required, observe applicable local laws and regulations.
- Take sufficient breaks.

Noise pollution can damage health and lead to loss of hearing.

- Always wear ear protection when operating.

Wearing wrong work clothing or being negligent regarding the personal protective equipment can result in serious injuries.

- Work clothing should be tight fitting but not impeding.
- Do not wear loose clothing (e.g. scarves, open jackets).
- Do not have long, loose hair.
- Do not wear jewellery (e.g. watches, chains, rings, etc.).
- Wear your personal protective equipment.
- Wear respiratory protection if working in a dusty environment.
- If required, observe applicable local laws and regulations.

Never operate a machine which is not safe in its function.

Never operate a machine without or with damaged safety elements.

Always work with sufficient lighting.

Children cannot assess dangers and behave unpredictably.

- Delimit the working area.
- Prevent unauthorized persons, especially children, from accessing the machine as well as fuels and lubricants.
- Stop work immediately if a child approaches.

Obstacles or holes in the working area can cause slipping, stumbling or falling.

- Look out for obstacles or holes in the working area.
- If possible, remove obstacles before starting work.

A wrong working methods can result in serious injuries.

- Operate the machine only according to its intended use.
- Always work calmly and concentratedly.
- Guide the machine only by the guide handle.
- Guide the machine so that your hands do not hit against solid objects.
- Keep feet clear of the vibrating base plate.
- Ensure a firm stand and keep your balance. Special care must be taken on uneven ground.

Concerning your safety – Basic safety regulations for safe operation

- The machine must not tip, roll off, slide down or fall during operation.
- Observe the gradability and the maximum cross slope of the machine ↪ *Chapter 2 „Technical data“ on page 11.*

Check how the vibrations affect the working environment.

- The load bearing capacity of the soil can be reduced by the vibration effect.
- The side walls of trenches, construction pits and slopes must be stable and mustn't crumble when exposed to vibration.
- When compacting with vibration, you must always check the effect of the vibration on nearby buildings and underground supply lines (gas, water, sewage, electric power).
- If necessary, stop compacting with vibration.
- If unsure, consult an expert / qualified person to assess the working environment.

Components can be very hot during or immediately after operation (e.g. engine, exhaust, exciter system).

- Do not touch hot components.
- Keep waste such as paper, dry leaves or dry grass away from hot components.
- Keep a fire extinguisher at hand.

Gasoline is explosive!

- Safety regulations and environmental protection regulations must be followed when handling gasoline.
- Do not allow gasoline to come into contact with hot components.
- Before filling up, turn off the engine and let the machine and engine cool down.
- Smoking and open fire is prohibited.
- Keep away from heat sources, sparks and other sources of ignition.
- Do not spill any gasoline.

Danger to life caused by an operationally unsafe machine!

- The machine must only be serviced and repaired by qualified and authorized personnel.
- Contact our customer service to carry out the required maintenance work or necessary repairs.

3.4 Handling fuels and lubricants

3.4.1 Preliminary remarks

The operating company must ensure that all professional users have read and follow the corresponding safety data sheets for the individual fuels and lubricants.

Safety data sheets provide valuable information about the following characteristics:

- name of substance
- possible dangers
- composition / information on constituents
- first-aid measures
- fire fighting measures
- measures in case of accidental release
- handling and storage
- limitation and monitoring of exposure / personal protective equipment
- physical and chemical properties
- stability and reactivity
- toxicological data
- environmental data
- notes on waste disposal
- information on transport
- legislation
- other data

3.4.2 Safety regulations and environmental protection regulations for handling oil

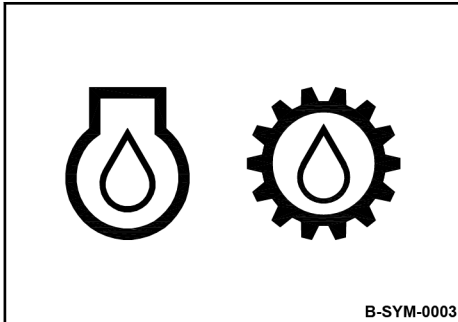

Fig. 4



WARNING!

Danger of burning by ignited oil!

- Do not allow oil to come into contact with hot components.
- Smoking and open fire is prohibited!
- Wear your personal protective equipment (protective gloves, protective clothing).



CAUTION!

Health hazard caused by contact with oil!

- Wear your personal protective equipment (protective gloves, protective clothing).
- Do not inhale any oil vapours.
- Avoid contact.



CAUTION!

Danger of slipping on spilled oil!

- Immediately bind spilled oil with an oil-binding agent.



ENVIRONMENT!

Oil is an environmentally hazardous substance!

- Always keep oil in proper containers.
- Immediately bind spilled oil with an oil-binding agent.
- Dispose of oil and oil filter according to regulations.

3.4.3 Safety regulations and environmental protection regulations for handling gasoline

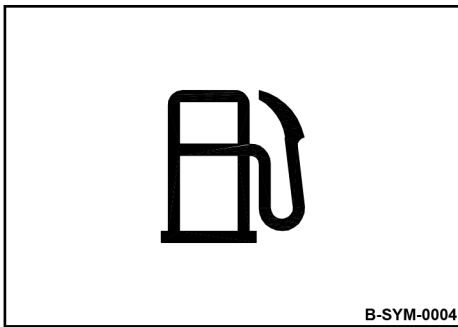

Fig. 5



DANGER!

Danger to life caused by explosive gas-air mixes!

- Do not allow gasoline to come into contact with hot components.
- Smoking and open fire is prohibited.
- Keep away from heat sources, sparks and other sources of ignition.
- Do not spill any gasoline.



WARNING!

Health hazard caused by contact with gasoline!

- Wear your personal protective outfit (protective gloves, protective clothing).
- Do not inhale any fuel fumes.
- Do not swallow gasoline.
- Avoid contact with gasoline.



ENVIRONMENT!

Gasoline is an environmentally hazardous substance!

- Always keep gasoline in proper containers.
- Immediately bind spilled gasoline with an oil-binding agent and dispose of in accordance with regulations.
- Dispose of gasoline and fuel filter according to regulations.

3.4.4 Safety regulations and environmental protection regulations for handling fuel stabiliser



WARNING!

Danger of burning by ignited fuel stabilizer!

- Do not allow fuel stabilizer to come into contact with hot components.
- Smoking and open fire is prohibited.



WARNING!

Health hazard caused by contact with fuel stabilizer!

- Wear your personal protective outfit (protective gloves, protective clothing).
- Do not inhale any fuel stabilizer fumes.
- Do not swallow fuel stabilizer.
- Avoid contact with fuel stabilizer.



ENVIRONMENT!

Fuel stabilizer is an environmentally hazardous substance!

- Immediately bind spilled fuel stabilizer with an oil-binding agent and dispose of according to regulations.
- Dispose of fuel stabilizer according to regulations.

3.5 Loading / transporting the machine

Observe locally applicable laws and regulations when loading and transporting.

Attaching and hoisting loads with lifting gear must only be performed by an expert / qualified person.

Use only lifting tackle with sufficient load bearing capacity for the weight to be loaded.

Fasten the lifting gear only at the specified lifting points.

Alternatively the machine can be lifted manually at the lashing points.

Always lift the machine with the help of a second person. The machine is too heavy to lift alone.

Danger to the life of persons if they step or stand under a suspended load.

Do not use damaged lifting or lashing points.

Insufficient load restraints can cause serious accidents.

- Secure the machine on the transport vehicle against rolling, slipping and turning over.

3.6 Start-up procedure

3.6.1 Prior to starting up

Use only machines which are serviced at regular intervals.

Become acquainted with the equipment, the indicators and control elements, the working principle of the machine and the working area.

Use your personal protective equipment (hard hat, safety boots, if necessary also goggles and ear protection).

Do not take any loose objects with you or fasten them to the machine.

Before start up, check whether:

- persons or obstructions are beside or in front of the machine,
- the machine is free of oily and combustible materials,
- all safety elements are in place,
- all grips are free of grease, oils, fuel, dirt, snow and ice.

Before start up, carry out all required visual inspections and function tests.

If the following tests reveal damages or other faults, the machine must not be operated, until these deficiencies have been corrected.

Do not operate the machine with defective indicators and control elements.

3.6.2 Starting the engine

Do not use any starting aids like start pilot or ether.

The machine must not be operated with damaged, missing or non-functional safety installations.

Before starting and moving the machine, make sure that there is nobody in the danger zone.

Always keep an eye on the machine when the engine is running and hold it by the steering bow.

Do not inhale exhaust fumes, because they contain toxic substances, which could cause damage to health, unconsciousness or even death.

Avoid operation in closed or partly closed rooms, or ensure adequate ventilation when working in trenches.

3.7 Operation

3.7.1 Persons in the danger zone

Before taking up work, also after breaks, you should always convince yourself that the danger zone is free of persons or obstructions.

Give warning signals, if necessary. Stop work immediately if persons remain in the danger zone, despite the warning.

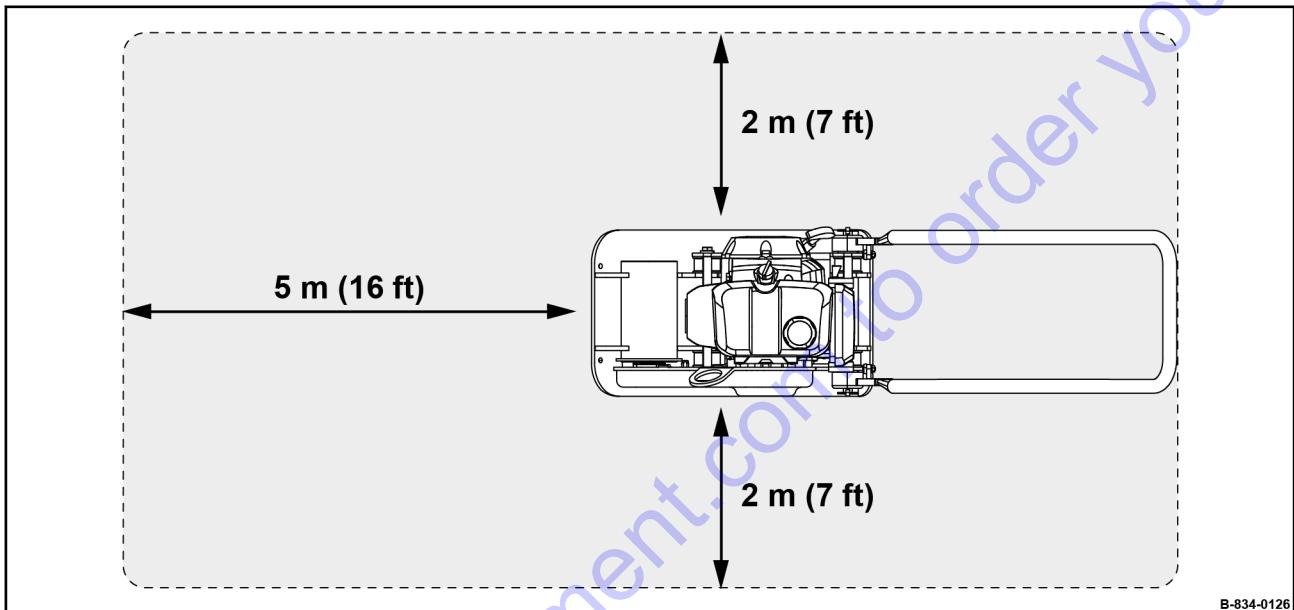

Fig. 6: Danger zone

3.7.2 Operation

Guide the machine only by the guide handle.

Guide the machine so that your hands do not hit against solid objects.

Watch out for unusual noises and development of smoke. Perform trouble shooting and have the fault corrected.

Always keep a safe distance to excavation pit borders, embankments and edges.

Refrain from any work that could adversely affect the stability of the machine.

Observe the daily vibration load (work safety acc. to 2002/44/EC).

3.7.3 Parking the machine

Park the machine on horizontal, level, firm ground.

Concerning your safety – Operation

Before leaving the machine:

- Shut down the engine,
- Secure the machine against accidental tipping over,
- Secure the machine against unauthorized use.

Mark machines, which could be in the way, with a clearly visible sign.

Go to Discount-Equipment.com to order your parts

3.8 Refuelling

Do not inhale any fuel fumes.

Refuel only with the engine shut down.

Do not refuel in closed rooms.

No open fire, do not smoke.

Keep away from ignition and heat sources.

Apply measures against electrostatic charging.

Do not spill any fuel. Catch running out fuel, do not let it seep into the ground.

Wipe off spilled fuel. Keep dirt and water away from the fuel.

A leaking fuel tank can cause an explosion. Ensure tight fit of the fuel tank cover, if necessary replace immediately.

Go to Discount-Equipment.com to order your parts

3.9 Maintenance work

3.9.1 Preliminary remarks

Adhere to the specified operating, maintenance and repair measures.

The machine must only be serviced by qualified personnel authorised by the operating company.

Keep unauthorised persons away from the machine.

Perform maintenance work only with the engine shut down and the spark plug connector disconnected.

Do not touch hot components.

Do not leave any tools or other objects, that could cause damage, in or on the machine.

3.9.2 Working on the engine

Drain the engine oil at operating temperature – danger of scalding!

Wipe off spilled oil, catch running out oil and dispose of environmentally.

When working on the air filter no dirt should fall into the air duct.

Do not work on the hot exhaust - danger of burning!

Store used filters and other oil contaminated materials in a separate, specially marked container and dispose of environmentally.

3.9.3 Cleaning work

Do not perform cleaning work while the motor is running.

Allow the engine to cool down before starting cleaning work.

Do not use gasoline or other easily inflammable substances for cleaning.

3.9.4 After maintenance work

Reassemble all guards and protections.

3.10 Repair

Identify a defect machine with a warning sign.

Only operate the machine after it has been repaired.

When replacing safety relevant components, only original spare parts must be used.

Repairs must only be performed by an expert/qualified person.

When performing welding work on the machine you should cover the fuel tank with insulating material.

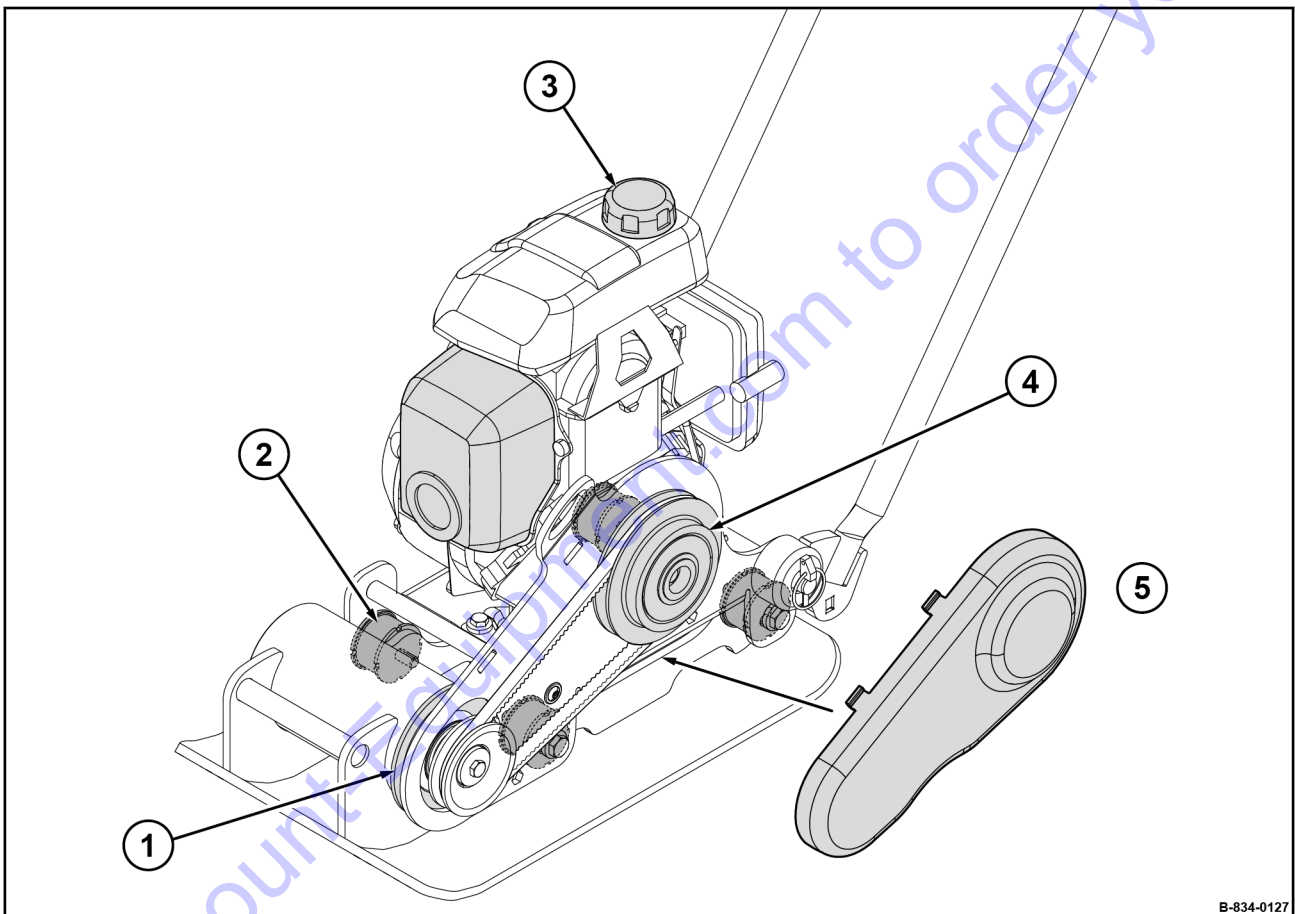

B-834-0127

Fig. 7: Safety relevant components

- 1 Rubber seal
- 2 Rubber buffer
- 3 Fuel tank cap
- 4 Centrifugal clutch
- 5 V-belt guard

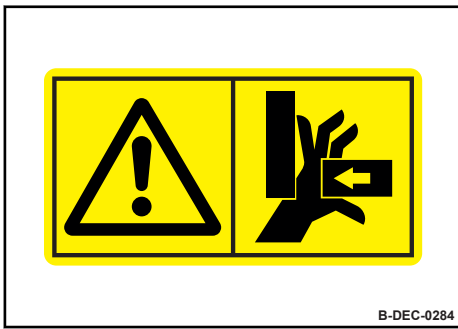

Warning sticker - Crushing hazard for hands

Fig. 10



Instruction sticker - Wear ear defenders

Fig. 11



Instruction sticker - Wear safety shoes

Fig. 12

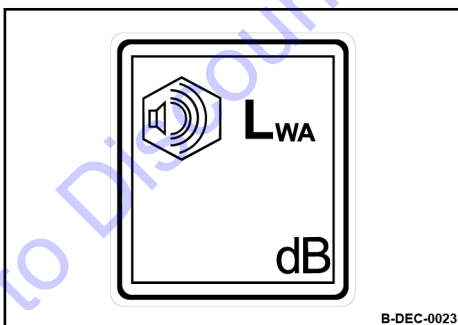

Information sticker - Guaranteed sound capacity level

Fig. 13

Concerning your safety – Signage

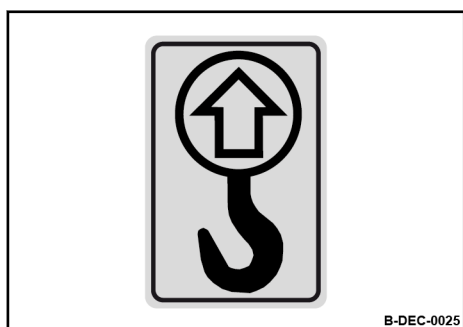

Information sticker - Lifting point

Fig. 14

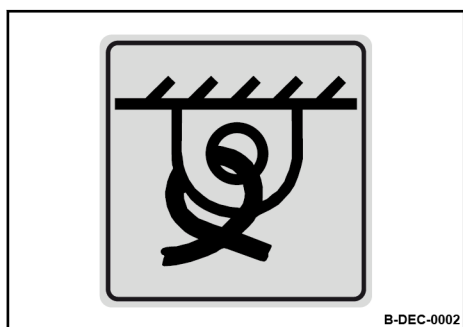

Information sticker - Lashing point

Fig. 15



Information sticker - Gasoline

Fig. 16

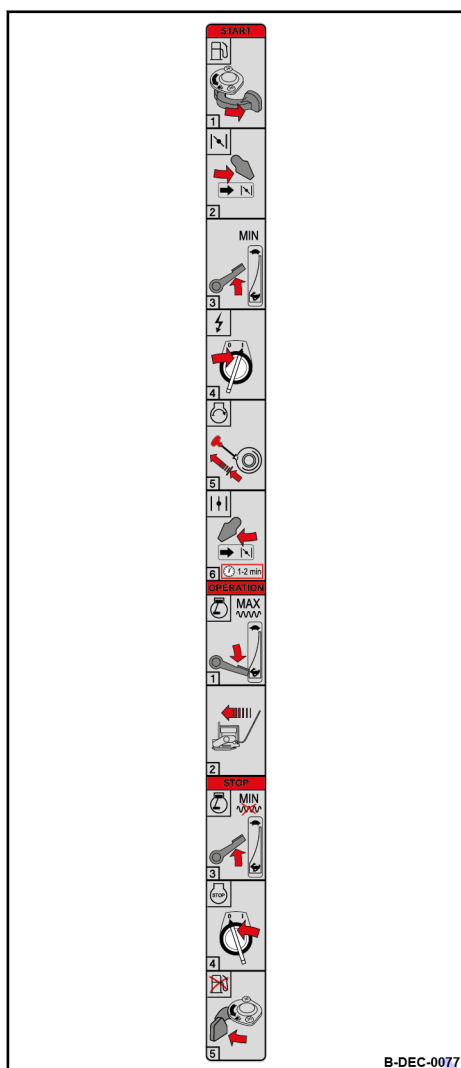

Brief operating instructions

Fig. 17

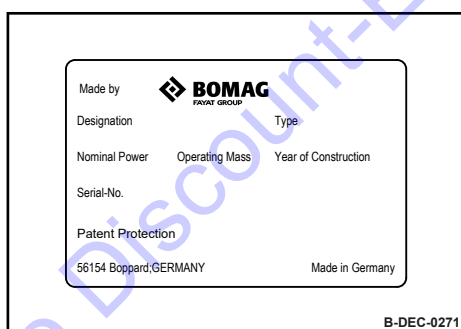

Machine type plate (example)

Fig. 18

4

Machine description

Go to Discount-Equipment.com to order your parts

Machine description – Function and design

4.1 Function and design

This machine is suited for the compaction of gravel, sand and mixed soils, for smaller repairs in asphalt construction, as well as for the vibratory compaction of paving stones.

An additional plastic mat must be used for the vibratory compaction of paving stones to prevent damaging the stone surface.

All other materials can be compacted without the plastic mat.

The plastic mat is available as an accessory.

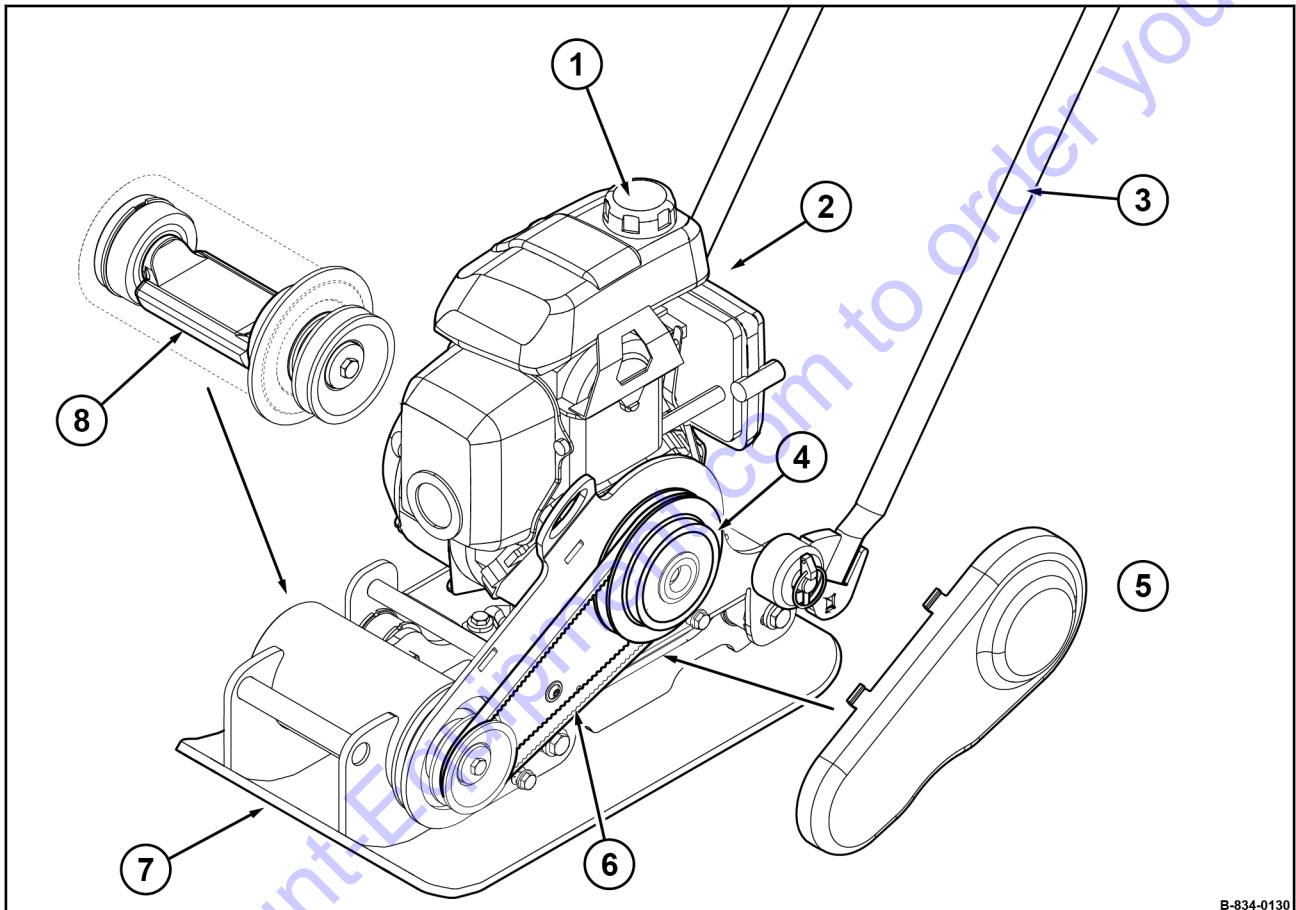

Fig. 19

- 1 Fuel tank
- 2 Engine
- 3 Guide handle
- 4 Centrifugal clutch
- 5 V-belt guard
- 6 V-belt
- 7 Base plate
- 8 Exciter shaft

The compaction is achieved by the vibration of the base plate (7).

The base plate vibration and the machine's forward movement are generated by the exciter shaft (8).

If the engine (2) is running at idle speed, there is no power transmission to the exciter shaft.

Machine description – Function and design

Only when the engine speed increases does the centrifugal clutch (4) engage and the engine speed is transmitted to the exciter shaft via the V-belt (6).

Models

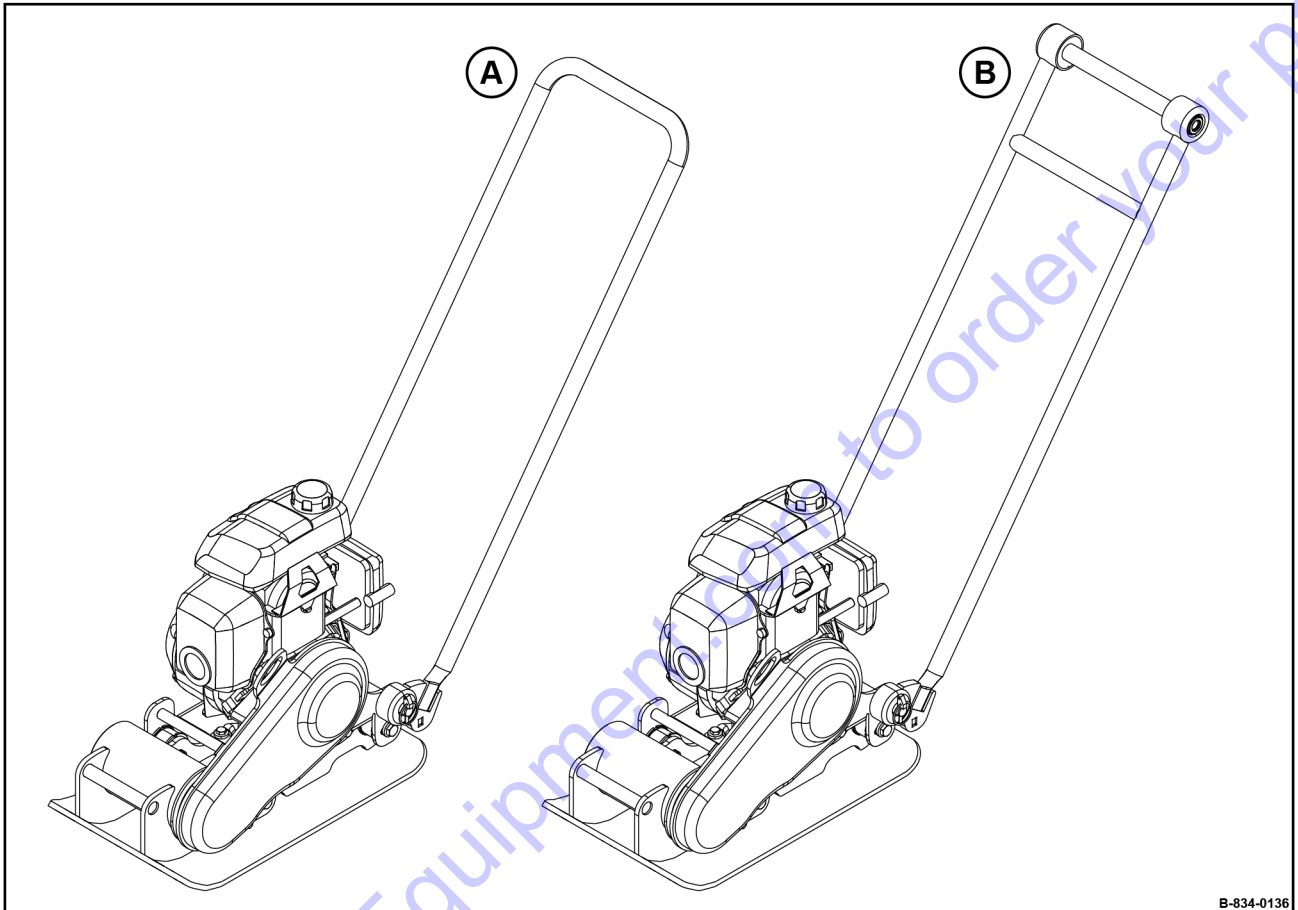

Fig. 20

The machine is available in two models:

- A - Machine with standard guide handle
- B - Machine with comfort guide handle (reduced hand-arm vibrations)

Machine description – Function and design

Accessories

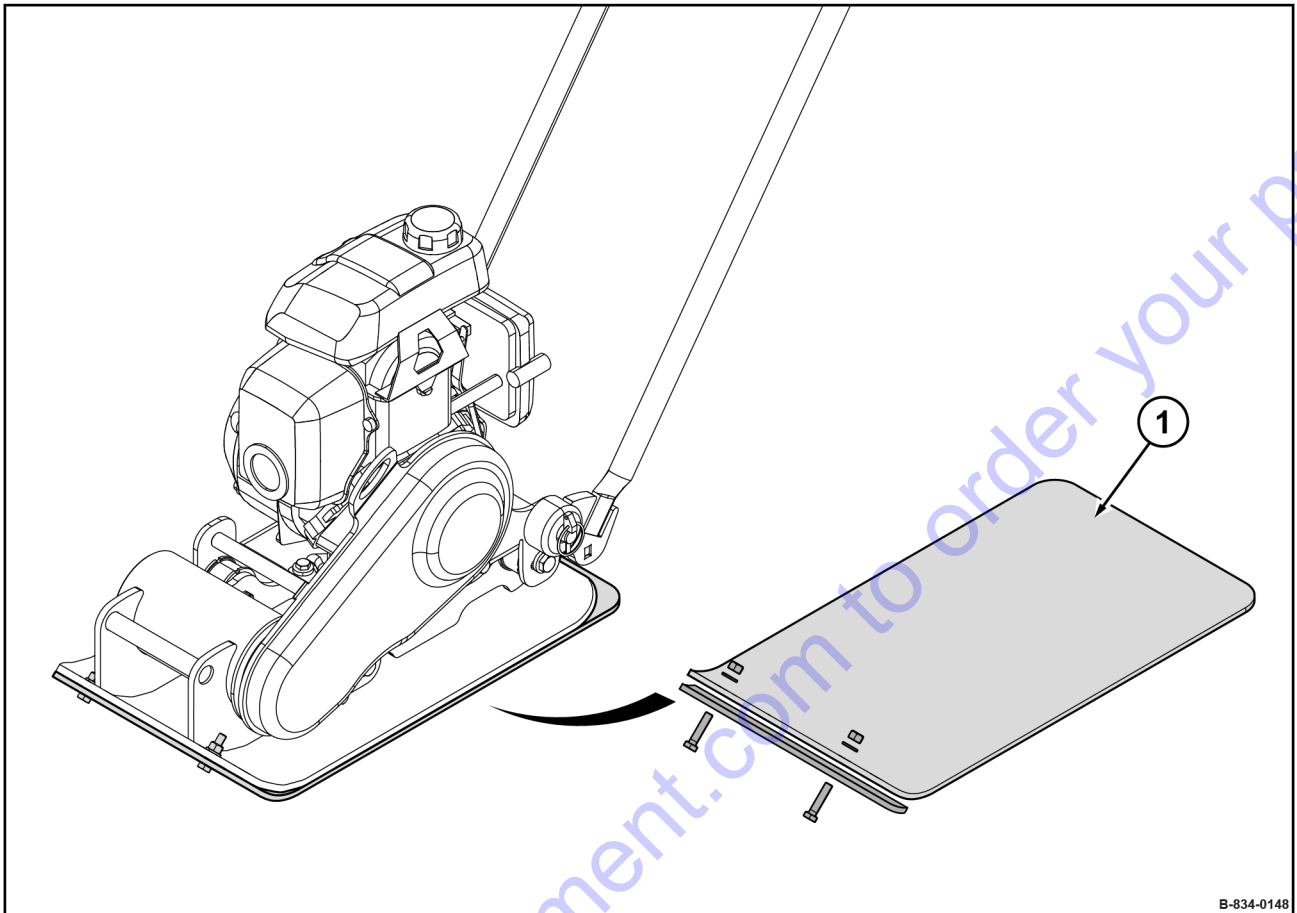

Fig. 21

- 1 Plastic mat for the vibratory compaction of paving stones

4.2 Indicators and control elements

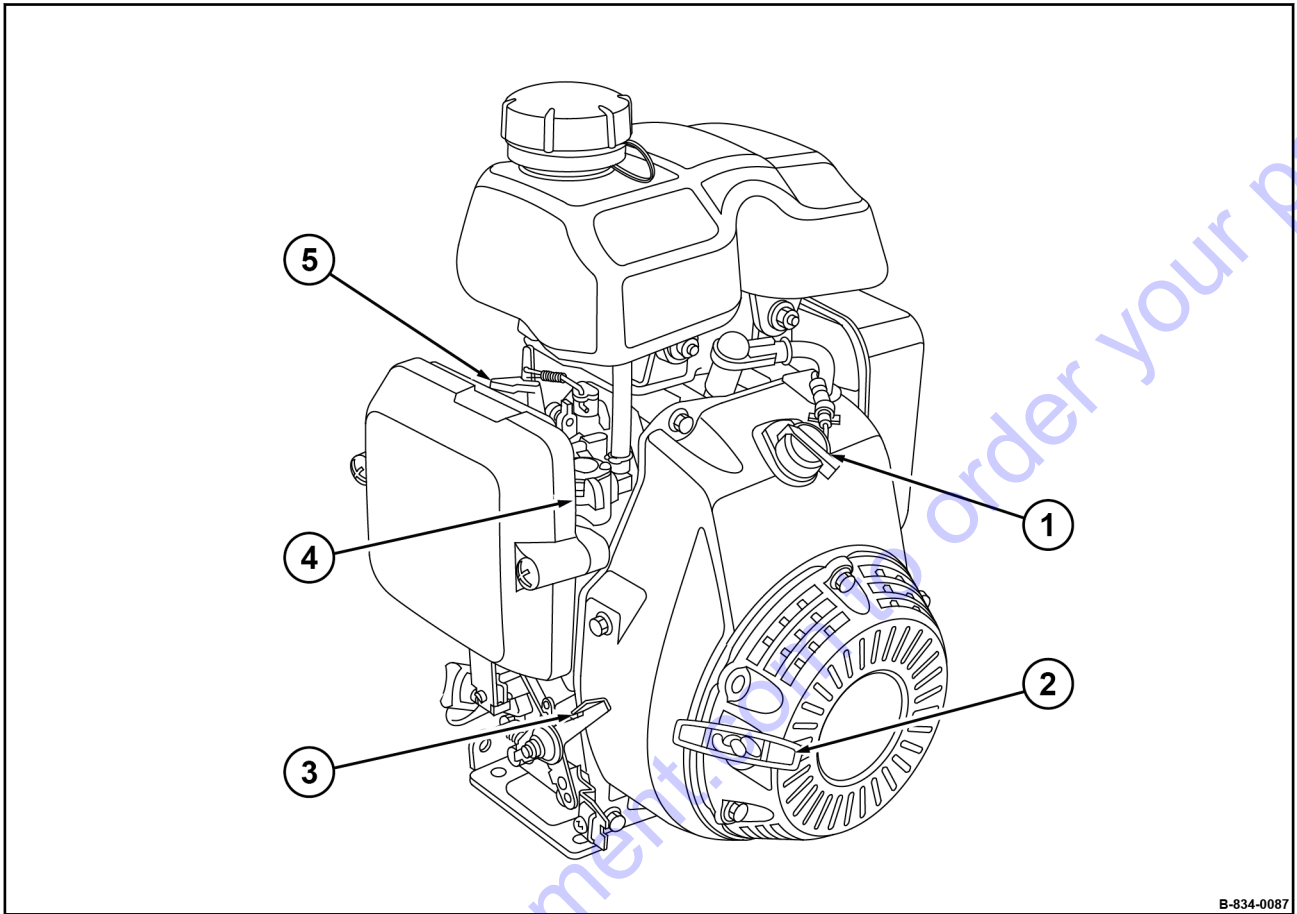
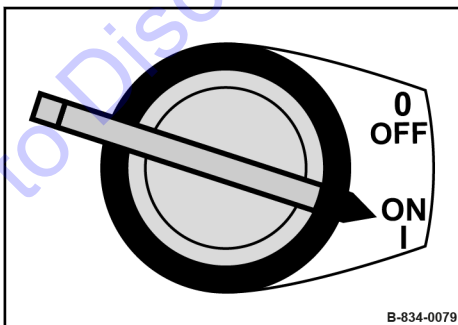

Fig. 22

- 1 Starter switch
- 2 Recoil starter
- 3 Throttle lever
- 4 Fuel valve
- 5 Choke lever

4.2.1 Starter switch



Position "OFF"	Ignition off
Position "ON"	Ignition on

Fig. 23

4.2.2 Recoil starter

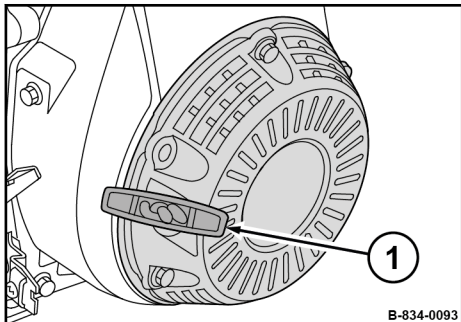

1 Starter handle

Fig. 24

4.2.3 Throttle lever

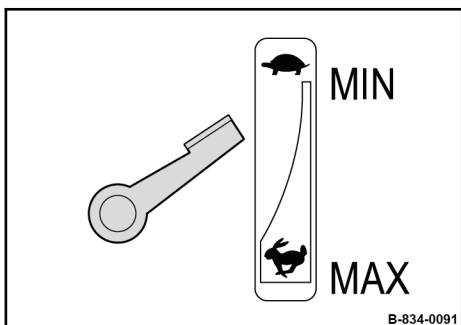

Fig. 25

Position "Top"	Position "MIN" Idle speed
Position "Bottom"	Position "MAX" maximum engine speed

4.2.4 Fuel valve

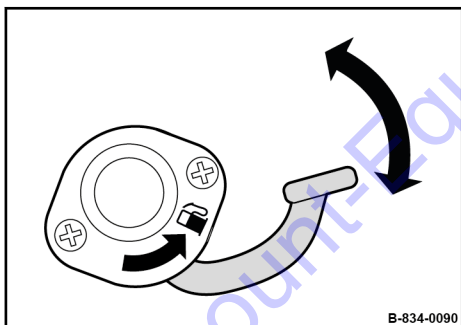

Fig. 26

Turn the lever in the arrow direction	Open the fuel valve
Turn the lever against the arrow direction	Close the fuel cock

4.2.5 Choke lever

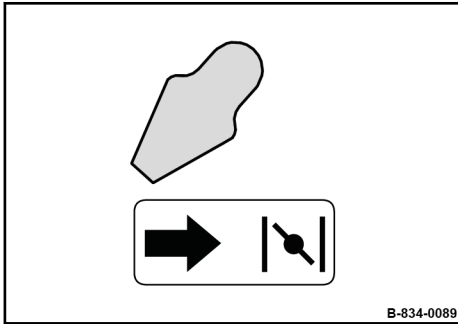

Fig. 27

Turn the lever in the arrow direction

Close the choke

Turn the lever against the arrow direction

Open the choke



Close the choke only when with the engine is cold. If the engine is warm or the outside temperatures are high, the choke must remain open to prevent the engine from stalling.

Go to Discount-Equipment.com to order your parts

5

Checks prior to start up

Go to Discount-Equipment.com to order your parts

5.1 Notes on safety

If the following tests reveal damages or other defects, the machine must not be operated, until these deficiencies have been corrected.

Do not operate the machine with defective indicators and control elements.

Safety installations must not be removed or made ineffective.

Do not change any fixed settings.



WARNING!

Health hazard caused by fuels and lubricants!

- Safety regulations and environmental protection regulations must be followed when handling fuels and lubricants ↪ *Chapter 3.4 „Handling fuels and lubricants“ on page 25.*



WARNING!

Danger of injury caused by rotating parts!

- Before starting work on the machine make sure that the engine can not be started.

1. Park the machine safely ↪ *Chapter 6.6 „Parking the machine in secured condition“ on page 74.*

5.2 Visual inspections and function tests

Protective equipment: ■ Working clothes
■ Protective gloves

1. Park the machine in secured condition ↪ *Chapter 6.6 „Parking the machine in secured condition“ on page 74.*

Machine

2. Check machine for contamination and damage.

⇒ Remove waste such as paper, leaves or grass.

If necessary, have the machine cleaned by our customer service.

Have damaged components replaced by our customer service immediately.

Screw connections

3. Check the screw connections on the machine regarding condition and tight fit.

⇒ Have loose or damaged screw connections checked and, if necessary, replaced by our customer service immediately.

Fuel tank and fuel lines

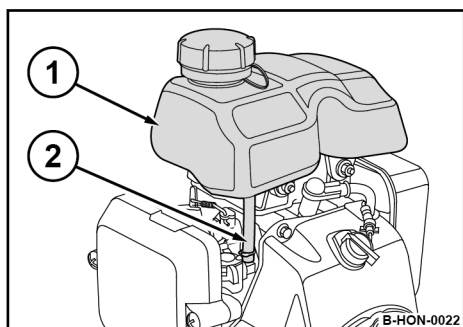

Fig. 28

4. Check fuel tank (1) and fuel hose (2) for condition and leaks.

⇒ Have a damaged fuel tank or fuel hose replaced by our customer service immediately.

Rubber buffer

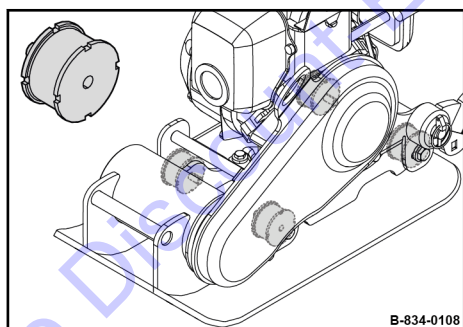

Fig. 29

5. Check all rubber buffers for tight fit, cracks and tear-offs.

⇒ Have damaged rubber buffers replaced by our customer service immediately.

Checks prior to start up – Visual inspections and function tests

Air intake area

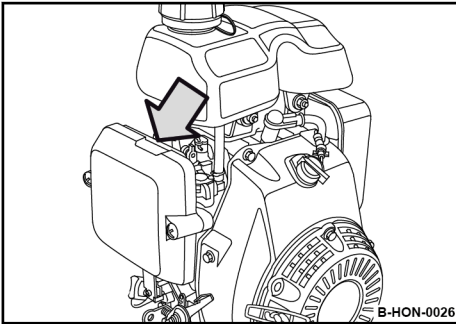

Fig. 30

6. Check the air intake area for dirt.
⇒ Remove contamination.

Starter rope

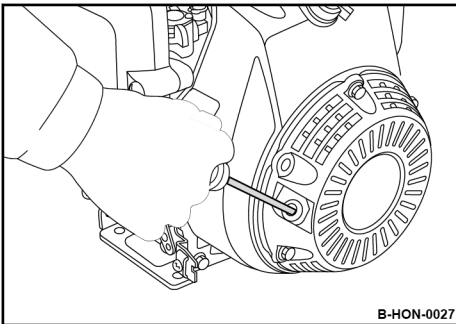

Fig. 31

7. Check the condition of the starter rope.
⇒ Have the damaged starter rope (e.g. chafing points, cracks) replaced by our customer service immediately.

5.3 Checking the engine oil level



NOTICE!

Danger of engine damage!

- +Use only oil of the permitted specification
↳ Chapter 8.2.1 „Engine oil“ on page 87.

Protective equipment: ■ Working clothes
■ Protective gloves

1. Park the machine in secured condition ↳ Chapter 6.6 „Parking the machine in secured condition“ on page 74.
2. Clean the area around the filler opening.

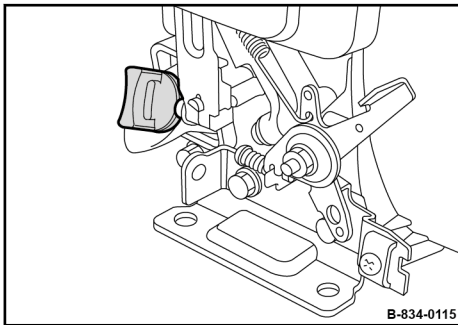

Fig. 32

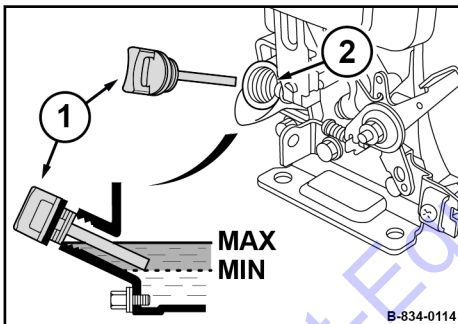

Fig. 33

3. Pull out the dipstick (1) and wipe it clean with a lint-free, clean cloth.
4. Insert the dipstick into the filler opening (2) without screwing it in.
5. Pull the dipstick out again.
⇒ The oil level must be between the “MIN” and “MAX” marks.

6.



NOTICE!

Danger of engine damage!

- Do not fill in too much engine oil.

If the oil level is too low, top up engine oil to the “MAX” mark.

7. Screw the oil dipstick in.

5.4 Checking the fuel level, topping up fuel



DANGER!

Danger to life caused by explosive gas-air mixes!

- Do not allow gasoline to come into contact with hot components.
- Smoking and open fire is prohibited.
- Keep away from heat sources, sparks and other sources of ignition.
- Do not spill any gasoline.



NOTICE!

Danger of engine damage!

- Monitor the entire refuelling process.
- Contaminated fuel can cause malfunction or even damage of the engine. If necessary, fill in fuel through a screen filter.
- Use only fuel of the permitted specification
↳ *Chapter 8.2.2 „Fuel“ on page 87.*

Protective equipment: ■ Working clothes
■ Protective gloves

1. Park the machine in secured condition ↳ *Chapter 6.6 „Parking the machine in secured condition“ on page 74.*
2. Let the machine and the engine cool down.
3. Clean the area around the filler opening (2).
4. Unscrew the cap (1).
5. Check the fuel level on the fuel tank (3).
6. Fill in fuel through a funnel with screen filter.
7. Screw the cap on.

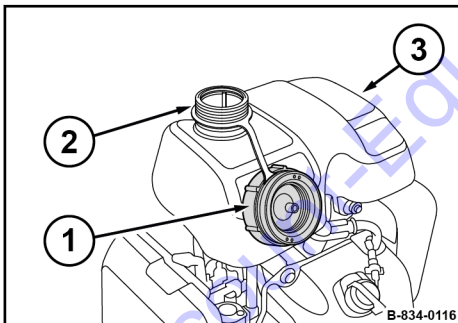

Fig. 34

Go to Discount-Equipment.com to order your parts

6.1 Initial start-up

1. Remove the packaging material completely.
2. Check condition and completeness of the machine.
3. Dispose of the packaging material in an environmentally friendly way.
4. Carry out checks prior to start up ↪ *Chapter 5 „Checks prior to start up“ on page 49.*
5. Start the engine ↪ *Chapter 6.4 „Starting the engine“ on page 67.*

Go to Discount-Equipment.com to order your parts

6.2 Guide handle

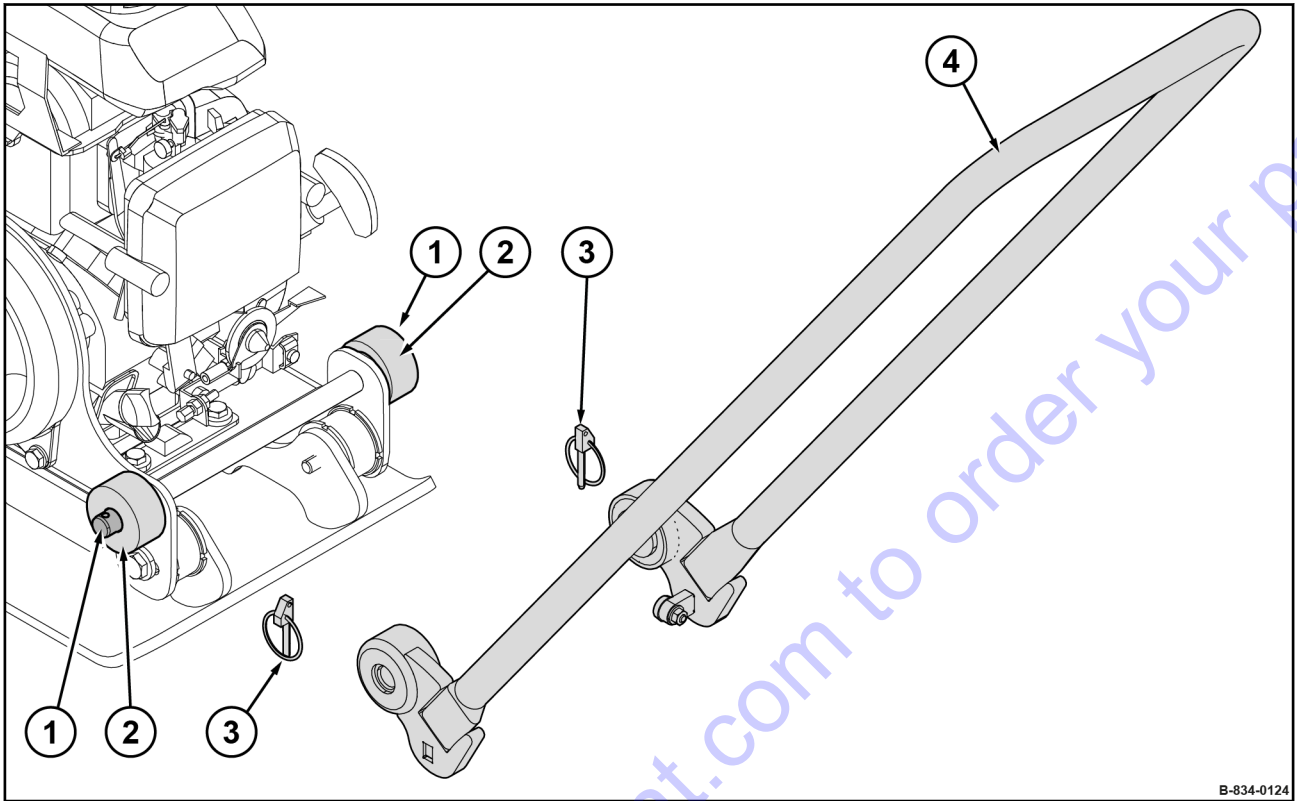

B-834-0124

Fig. 35

- 1 Holding fixture on the machine
- 2 Buffer
- 3 Clip pin to secure the guide handle
- 4 Guide handle

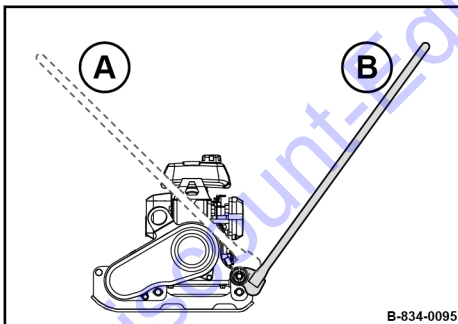

B-834-0095

Fig. 36

Position "A"	Transport position
Position "B"	Working position



The operating possibilities are the same for both versions of the guide handle.

Operation – Guide handle

6.2.1 Mounting the guide handle

Protective equipment: ■ Working clothes
■ Protective gloves

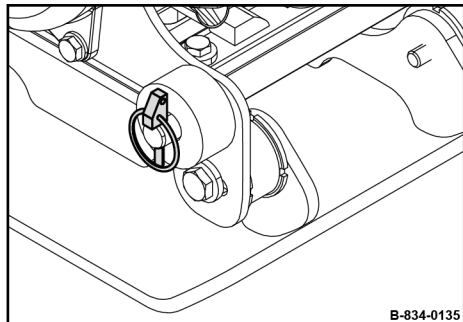

Fig. 37

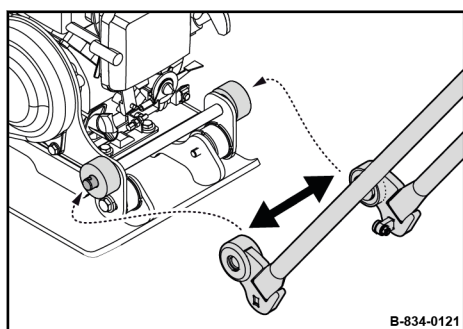

Fig. 38

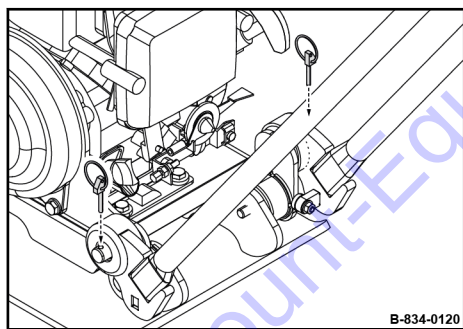
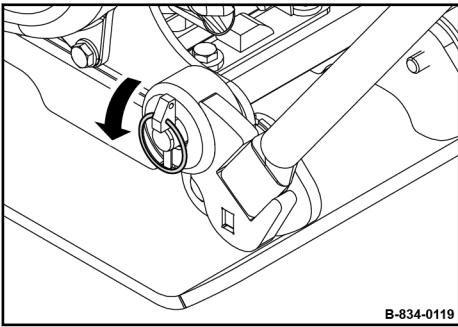

Fig. 39

1. If the clip pins are fastened to the holding fixtures:
Unfold clip pins on both sides and remove them.

2. Force the guide handle apart and plug it onto the holding fixtures.

3. Insert the clip pins through the bore on the holding fixtures.



4. Fold down the clip pins on both sides.

Fig. 40

Go to Discount-Equipment.com to order your parts

6.2.2 Removing the guide handle

Protective equipment: ■ Protective gloves
■ Working clothes

1. Park the machine in secured condition ↪ *Chapter 6.6 „Parking the machine in secured condition“ on page 74.*



WARNING!

Danger of burning on hot components!

- Wear your personal protective equipment (protective gloves, protective clothing).
- Avoid touching hot components.

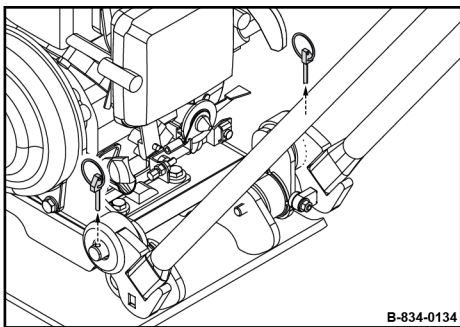

Fig. 41

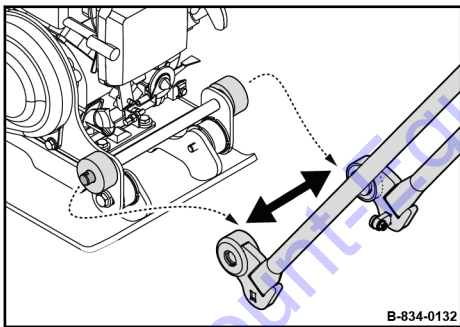

Fig. 42

2. Let the machine and the engine cool down to ambient temperature.
3. Unfold clip pins on both sides and remove them.
4. Force the guide handle apart and remove it from the holding fixtures.

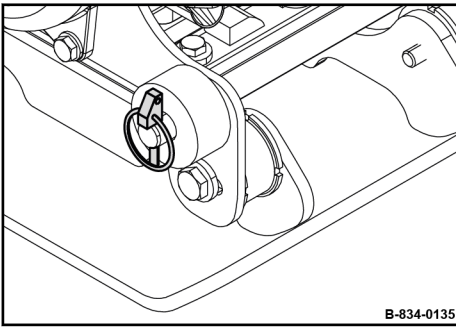

Fig. 43

5. Insert the clip pins through the bore of the holding fixtures and fold them down.

Go to Discount-Equipment.com to order your parts

6.3 Plastic mat

Use a plastic mat for the vibratory compaction of paving stones to prevent damaging the stone surface.

All other materials are compacted without the plastic mat.

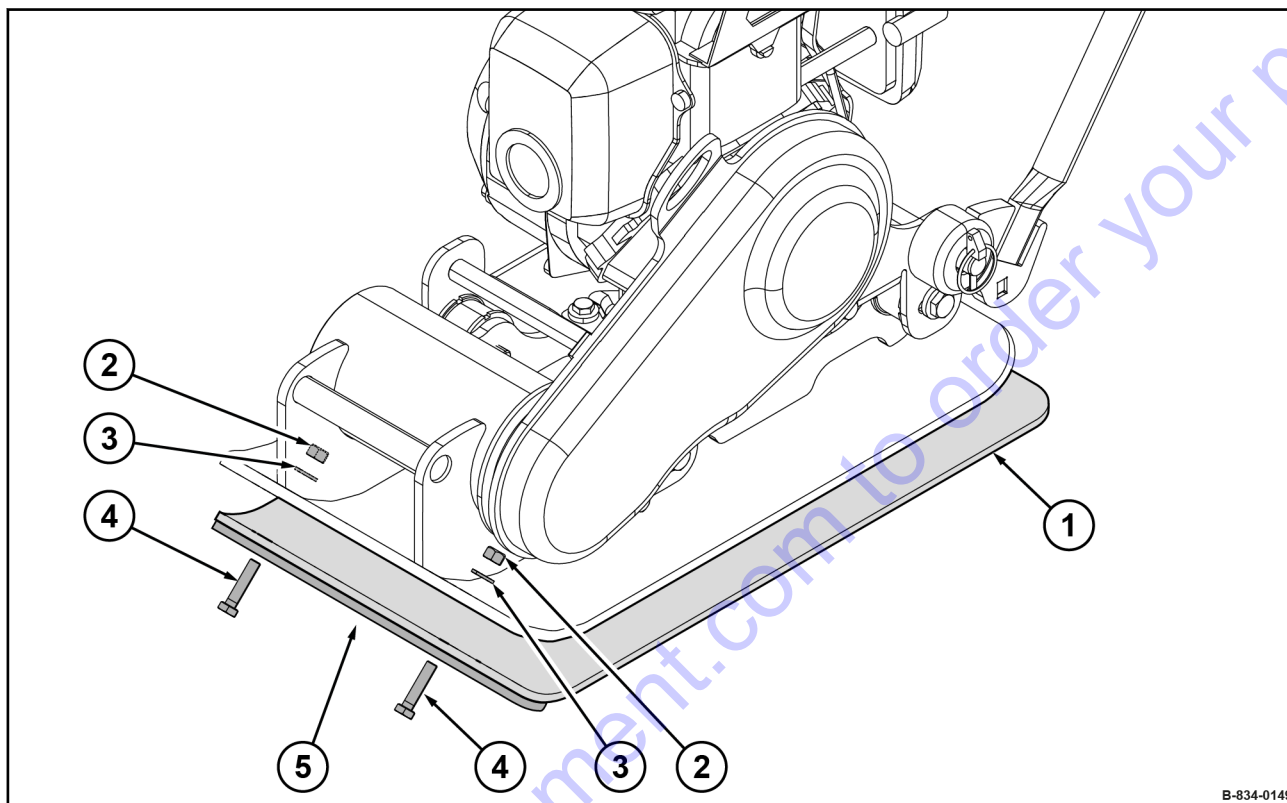

B-834-0149

Fig. 44

- 1 Plastic mat
- 2 Fastening nut
- 3 Washer
- 4 Fastening screw
- 5 Clamping strip

6.3.1 Mount the plastic mat

- Protective equipment:
- Working clothes
 - Protective gloves
 - Safety shoes

1. Park the machine in secured condition ↗ Chapter 6.6 „Parking the machine in secured condition“ on page 74.



WARNING!

Danger of burning on hot components!

- Wear your personal protective equipment (protective gloves, protective clothing).
- Avoid touching hot components.

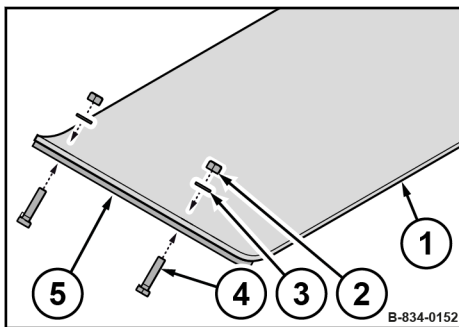

Fig. 45

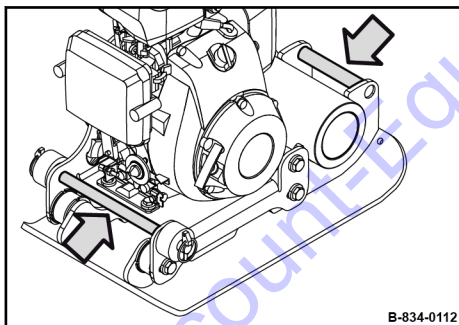

Fig. 46

2. Let the machine and the engine cool down to ambient temperature.
3. If the attachment parts (2 - 5) are screwed to the plastic mat (1):
 - Remove the fastening nuts (2) of the plastic mat (1) on both sides.
 - Remove washers (3), fastening screws (4) and clamping strip (5).

4. Check all lashing points including fastening elements for damage before lifting the machine.
 - ⇒ Do not use damaged or in any other way impaired lashing points.

Operation – Plastic mat

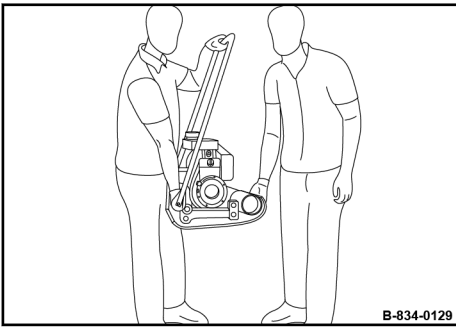

Fig. 47

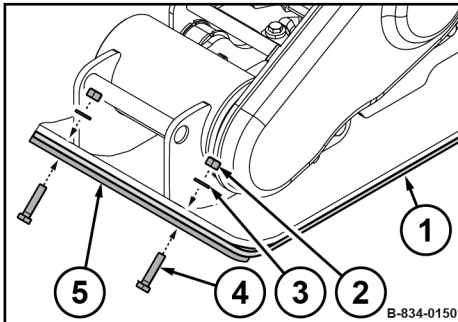

Fig. 48

5. Lift the machine with the help of a second person by means of the lashing points.

6. Hold the guide handle with one hand when lifting.

7. Set the machine down on the plastic mat (1).

8. Place the clamping strip (5) onto the plastic mat at the bottom.

9. Screw the plastic mat and clamping strip onto both sides of the base plate using fastening screws (4), washers (3) and fastening nuts (2).

6.3.2 Removing the plastic mat

- Protective equipment: ■ Working clothes
 ■ Protective gloves
 ■ Safety shoes

1. Park the machine in secured condition ↗ Chapter 6.6 „Parking the machine in secured condition“ on page 74.



WARNING!

Danger of burning on hot components!

- Wear your personal protective equipment (protective gloves, protective clothing).
- Avoid touching hot components.

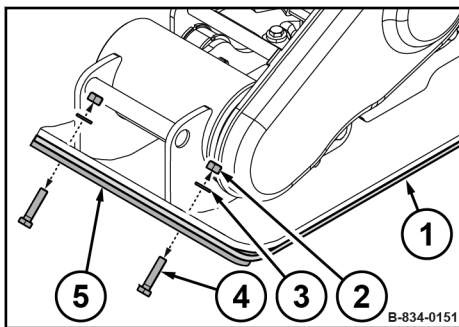

Fig. 49

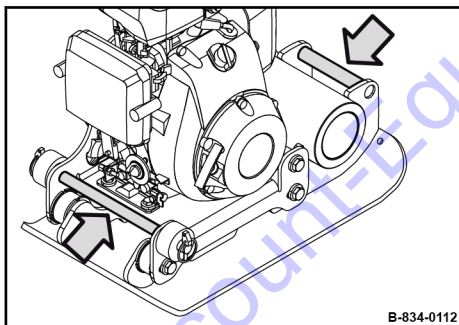

Fig. 50

2. Let the machine and the engine cool down to ambient temperature.
3. Remove the fastening nuts (2) of the plastic mat (1) on both sides.
4. Remove washers (3), fastening screws (4) and clamping strip (5).

5. Check all lashing points including fastening elements for damage before lifting the machine.
 - ⇒ Do not use damaged or in any other way impaired lashing points.

Operation – Plastic mat

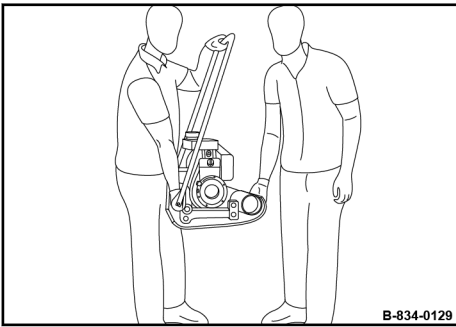

Fig. 51

6. Lift the machine with the help of a second person by means of the lashing points.
7. Hold the guide handle with one hand when lifting.
8. Park the machine on level, firm ground.

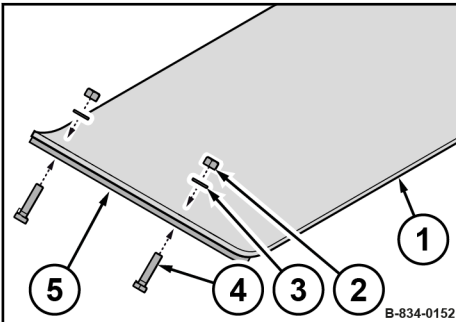

Fig. 52

9. Screw the clamping strip (5) onto both sides of the plastic mat using fastening screws (4), washers (3) and fastening nuts (2).

6.4 Starting the engine

Exhaust fumes contain toxic substances and can damage your health, cause unconsciousness or even death.



WARNING!

Danger of poisoning by exhaust gases!

- Do not inhale exhaust gases.
- Avoid operation in closed or partly closed rooms, or ensure adequate ventilation when working in trenches.

Components can be very hot during or immediately after operation.



WARNING!

Danger of burning on hot components!

- Wear your personal protective equipment (protective gloves, protective clothing).
- Avoid touching hot components.



WARNING!

Loss of hearing caused by too high noise burdens!

- Wear your personal protective equipment (ear protection).

Operate the machine only with the guide handle mounted and lowered.

Protective equipment:

- Hearing protection
- Working clothes
- Protective gloves
- Safety shoes

1. Mounting the guide handle ↪ *Chapter 6.2.1 „Mounting the guide handle“ on page 58.*
2. Fold down the guide handle into working position.
3. Make sure that no persons are in the danger zone.

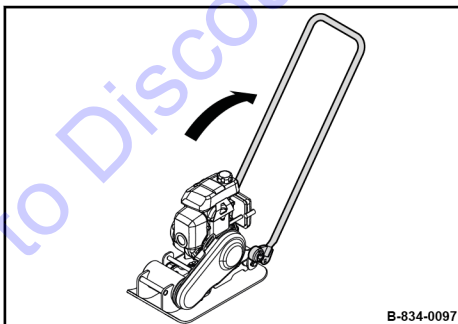

Fig. 53

Operation – Starting the engine

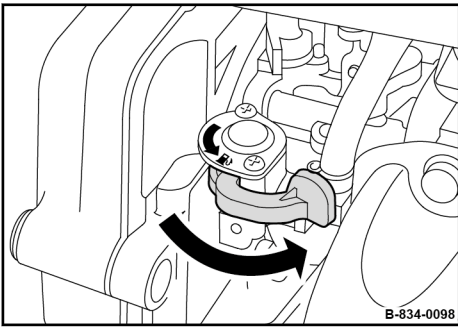

Fig. 54

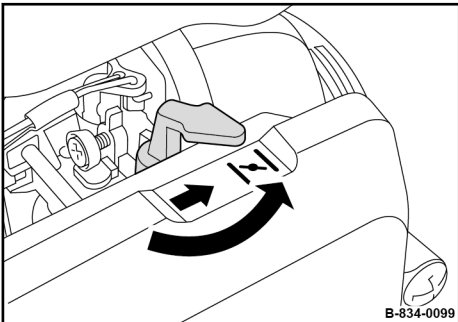

Fig. 55

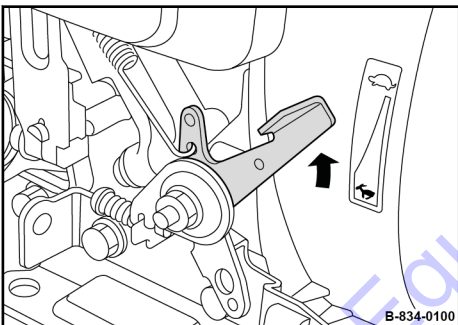

Fig. 56

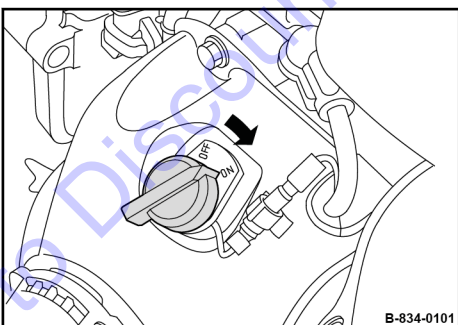

Fig. 57

4. Open the fuel tap completely.

- 5.



Close the choke only when with the engine is cold.

If the engine is warm or the outside temperatures are high, the choke must remain open to prevent the engine from stalling.

Close the choke with the choke lever.

6. Set the throttle lever to position "MIN".

7. Turn the starter switch to position "ON".

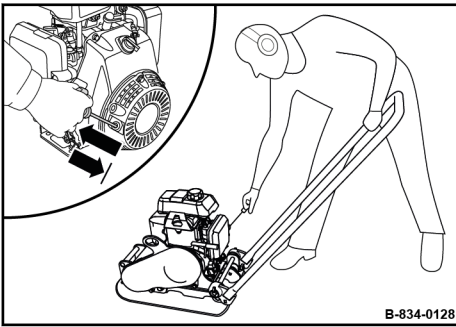

Fig. 58

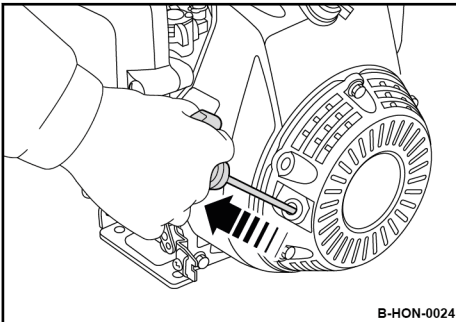

Fig. 59

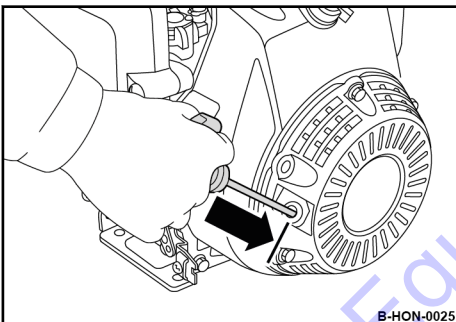

Fig. 60

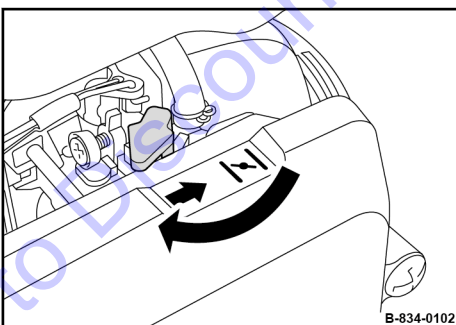

Fig. 61

8. Stand behind the machine on one side and hold the machine's guide handle with one hand.
9. Using the other hand, pull the rope by the starter handle, until resistance can be felt.
10. Guide the starter handle back to initial position.

11.



NOTICE!

The starter rope may tear off!

- Do not pull the starter rope all the way against the end stop.

Pull the starter handle quickly and with power.

⇒ The engine starts.

12. Manually guide the starter handle back to initial position.
13. If the engine does not start during the first attempt, repeat the starting process.

14. When the engine is running, open the lever of the choke bit by bit.



NOTICE!

Danger of engine damage!

- Warm up engine for a short while before starting work. Do not operate the engine immediately under full load.

15. Run the engine warm for approx. 1 to 2 minutes in idle speed.

⇒ At idle speed vibration is switched off.

Operation – Starting the engine

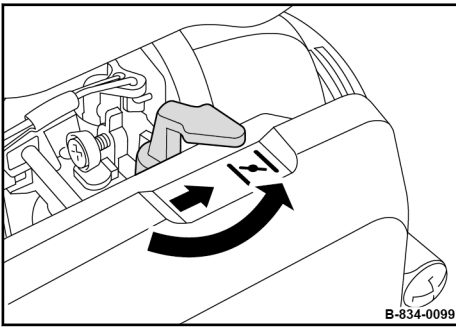

Fig. 62

16. Should the engine stop again after approx. 3 to 5 seconds:
- Close the choke again using the choke lever.
 - Repeat the starting procedure.



If the recoil starter is frequently operated with the choke closed and without the engine starting, the engine will draw in too much fuel and is unable to start. Chapter 9.3 „What to do if the engine has flooded“ on page 118.

6.5 Operation

Guide the machine only by the guide handle.

Guide the machine so that your hands do not hit against solid objects.

Keep feet clear of the vibrating base plate.



CAUTION!

Danger of injury caused by uncontrolled machine movement!

- Always hold on to a running machine.
- Always keep an eye on a running machine.

Go to Discount-Equipment.com to order your parts

Components can be very hot during or immediately after operation.



WARNING!

Danger of burning on hot components!

- Wear your personal protective equipment (protective gloves, protective clothing).
- Avoid touching hot components.



WARNING!

Loss of hearing caused by too high noise burdens!

- Wear your personal protective equipment (ear protection).

Protective equipment:

- Hearing protection
- Working clothes
- Protective gloves
- Safety shoes

1. Make sure that no persons are in the danger zone.



NOTICE!

The centrifugal clutch may be damaged!

- Operate the machine only with the throttle lever in position “MAX”.

2. Set the throttle lever to position “MAX”.
⇒ Machine vibrates forwards.

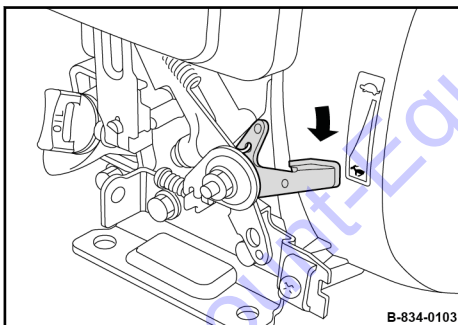

Fig. 63

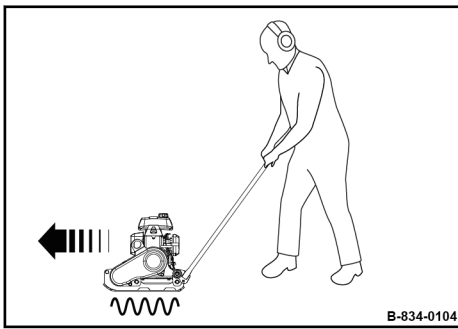

Fig. 64

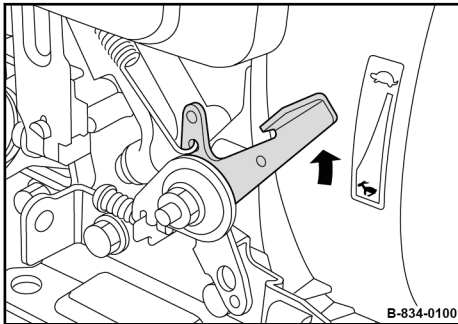

Fig. 65

3. Guide the machine by means of the guide handle.

4. For short work interruptions you should always return the throttle lever to position "MIN" (idle speed).

⇒ Vibration is switched off.

5. For short work interruptions you should always park the machine in secured condition *☞ Chapter 6.6 „Parking the machine in secured condition“ on page 74.*

6.6 Parking the machine in secured condition

Components can be very hot during or immediately after operation.



WARNING!

Danger of burning on hot components!

- Wear your personal protective equipment (protective gloves, protective clothing).
- Avoid touching hot components.

Protective equipment:

- Hearing protection
- Working clothes
- Protective gloves
- Safety shoes

1. Park the machine on level and firm ground.
2. Set the throttle lever to position “MIN” (idle speed).

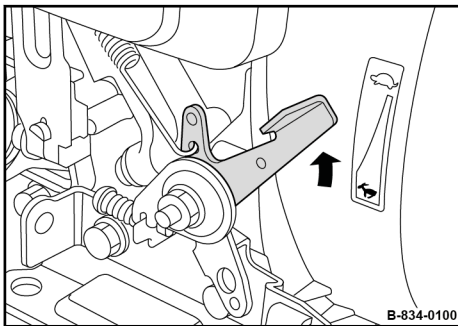

Fig. 66



NOTICE!

Danger of engine damage!

- Do not shut down the engine all of a sudden from full load speed, but let it idle for about two minutes.

3. Turn the starter switch to position “OFF”.
⇒ The engine is shut down.

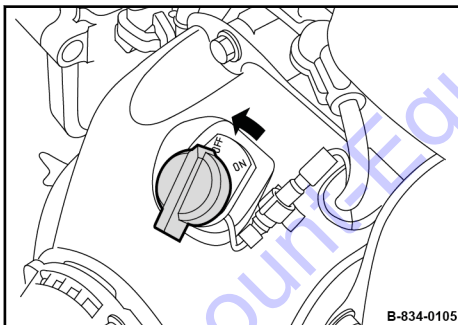

Fig. 67

Operation – Parking the machine in secured condition

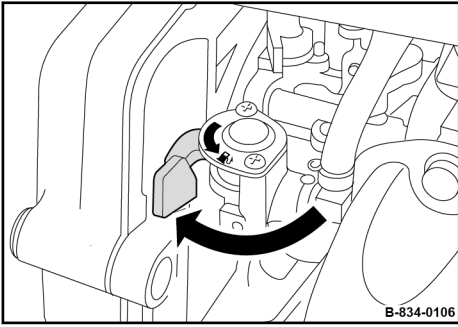

Fig. 68

4. Close the fuel valve completely.
5. Secure the machine against unauthorized use.

Go to Discount-Equipment.com to order your parts

7

Loading / transporting the machine

Go to Discount-Equipment.com to order your parts

7.1 Preliminary remarks and safety notes

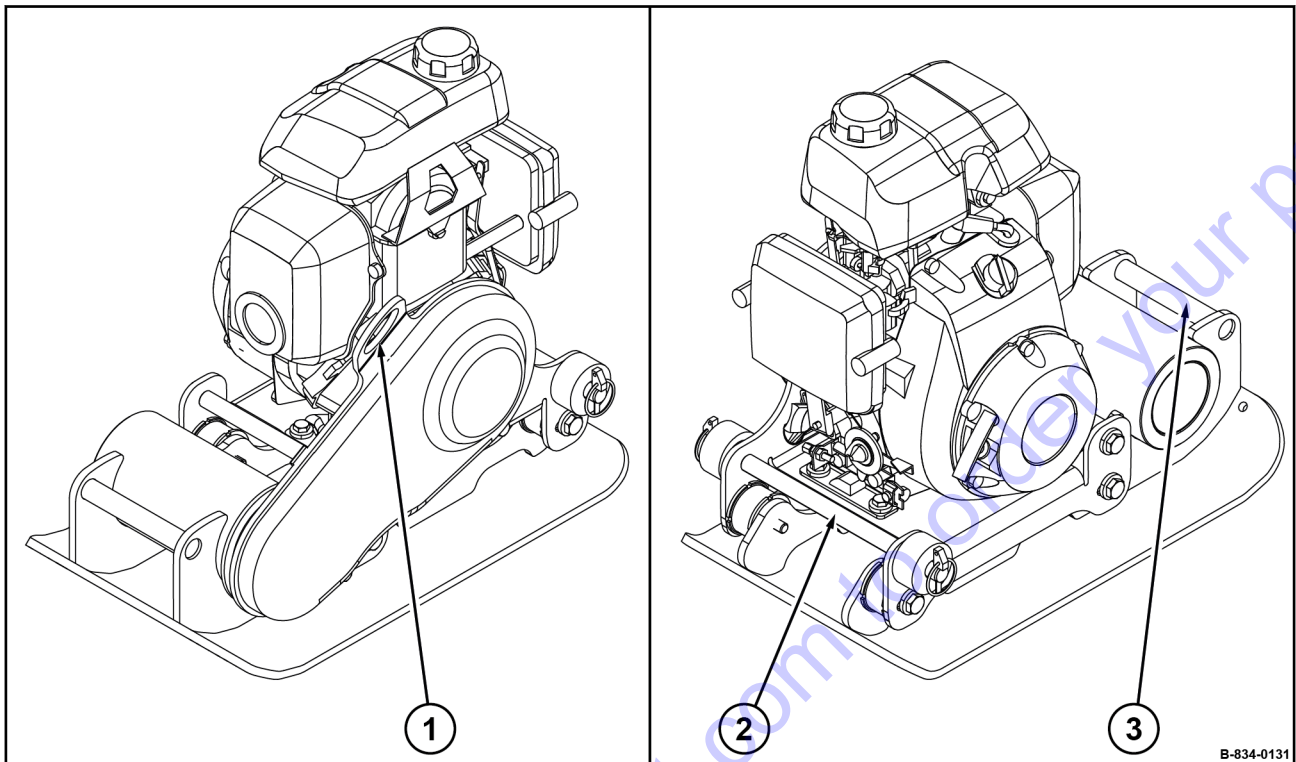

Fig. 69

- 1 Lifting point for lifting tackle
- 2 Rear lashing point
- 3 Front lashing point

Observe locally applicable laws and regulations when loading and transporting.

The machine can be lifted and loaded using lifting gear at the intended lifting point (1) (e.g. with a crane).

Attaching and hoisting loads with lifting gear must only be performed by an expert / qualified person.

Alternatively the machine can be lifted manually at the lashing points (2, 3).

Always lift the machine with the help of a second person. The machine is too heavy to lift alone.

7.2 Loading with lifting tackle

Use lifting tackle only in the prescribed direction of load application.

Lifting tackle must not be damaged by machine components.

Use only lifting tackle with sufficient load bearing capacity for the weight to be loaded. Minimum load bearing capacity of lifting tackle: see operating weight ↪ *Chapter 2 „Technical data“ on page 11.*

Protective equipment:

- Working clothes
- Protective gloves
- Safety shoes



WARNING!

Danger of burning on hot components!

- Wear your personal protective equipment (protective gloves, protective clothing).
- Avoid touching hot components.

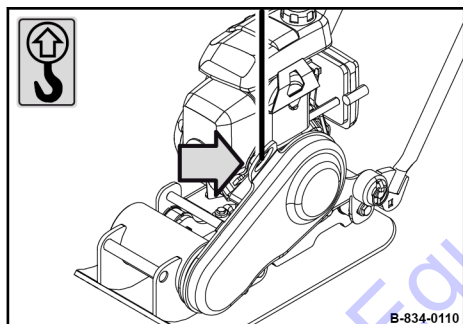

Fig. 70

1. Park the machine in secured condition ↪ *Chapter 6.6 „Parking the machine in secured condition“ on page 74.*
2. Let the machine and the engine cool down to ambient temperature.
3. Check the lifting point including fastening elements for damage before lifting the machine.
⇒ Do not use damaged or in any other way impaired lifting points.
4. Attach lifting tackle to the lifting point.
5. When lifting the machine, avoid uncontrolled movements of the load. If necessary, hold the load with guide ropes.
- 6.



DANGER!

Danger to life caused by suspended loads!

- Do not step or stand under suspended loads.

Lift the machine carefully and set it down on the transport vehicle.

7.3 Loading without lifting tackle

Protective equipment: ■ Protective gloves
■ Safety shoes



WARNING!

Danger of burning on hot components!

- Wear your personal protective equipment (protective gloves, protective clothing).
- Avoid touching hot components.

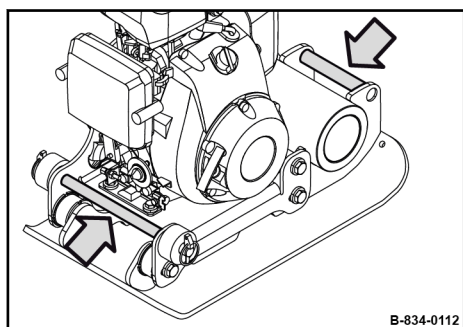

Fig. 71

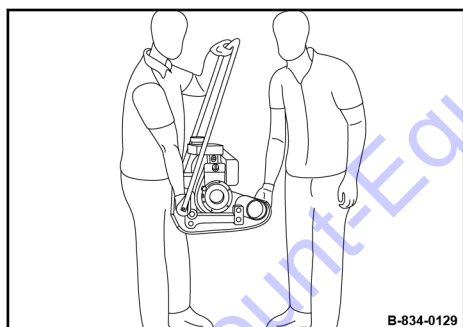

Fig. 72

1. Park the machine in secured condition ↪ Chapter 6.6 „Parking the machine in secured condition“ on page 74.
2. Let the machine and the engine cool down to ambient temperature.
3. Check all lashing points including fastening elements for damage before lifting the machine.
 - ⇒ Do not use damaged or in any other way impaired lashing points.
4. Lift the machine with the help of a second person by means of the lashing points.
5. Hold the guide handle with one hand when lifting.
6. Set the machine down on the transport vehicle.

7.4 Lashing the machine to the transport vehicle

Use lashing gear only in the prescribed direction of load application.

Lashing gear must not be damaged by machine components.

Protective equipment: ■ Working clothes
■ Protective gloves
■ Safety shoes



WARNING!

Danger of burning on hot components!

- Wear your personal protective equipment (protective gloves, protective clothing).
- Avoid touching hot components.

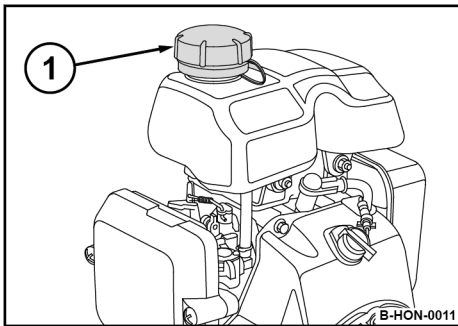

Fig. 73

1. Close the cap of the fuel tank tightly, so that fuel cannot leak out during transport.

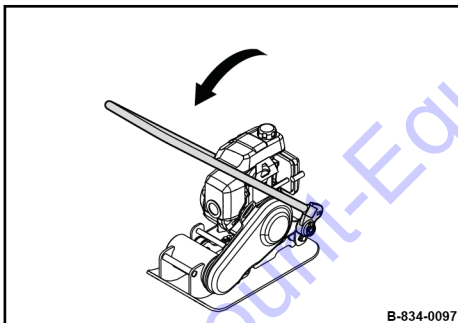

Fig. 74

2. Fold down the guide handle into transport position.

Loading / transporting the machine – Lashing the machine to the transport vehicle

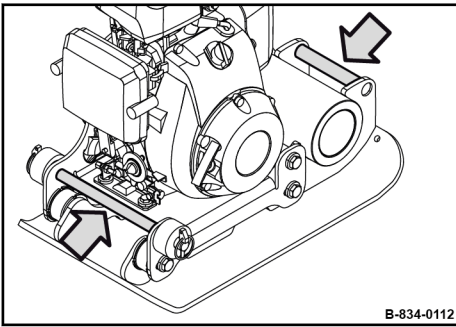

Fig. 75

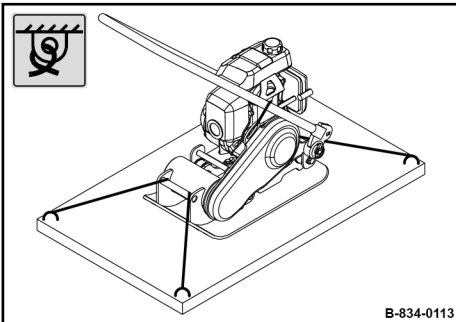

Fig. 76

3. If necessary, pull the machine on an even surface by means of the lashing points.

4. Fasten four ratchet straps to the marked lashing points.
5. Lash the machine securely to the transport vehicle.

7.5 After transport

Protective equipment: ■ Working clothes
■ Protective gloves
■ Safety shoes

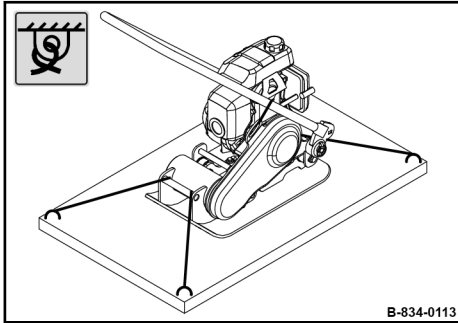

Fig. 77

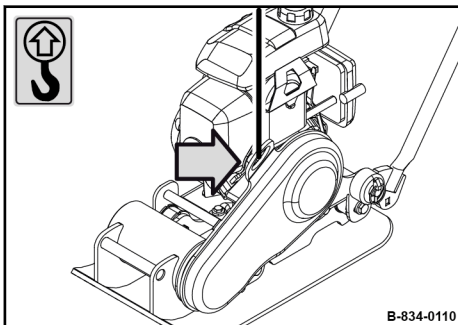

Fig. 78

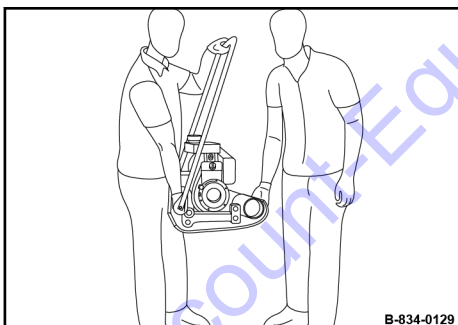

Fig. 79

1. Remove lashing gear.

2. Attach lifting tackle to the lifting point.

3. When lifting the machine, avoid uncontrolled movements of the load. If necessary, hold the load with guide ropes.

4.



DANGER!

Danger to life caused by suspended loads!

– Do not step or stand under suspended loads.

Raise the machine carefully.

5. Alternatively, lift the machine with the help of a second person by means of the lashing points.

Hold the guide handle with one hand when lifting.

6. Park the machine on level, firm ground.

7. Remove the lifting tackle.

Go to Discount-Equipment.com to order your parts

8.1 Preliminary remarks and safety notes



DANGER!

Danger to life caused by an operationally unsafe machine!

- The machine must only be serviced by qualified and authorized personnel.
- Follow the safety regulations for maintenance work ↪ *Chapter 3.9 „Maintenance work“ on page 34.*

Contact our customer service to carry out the required maintenance work.



WARNING!

Health hazard caused by fuels and lubricants!

- Safety regulations and environmental protection regulations must be followed when handling fuels and lubricants ↪ *Chapter 3.4 „Handling fuels and lubricants“ on page 25.*



WARNING!

Danger of injury caused by rotating parts!

- Before starting work on the machine make sure that the engine can not be started.

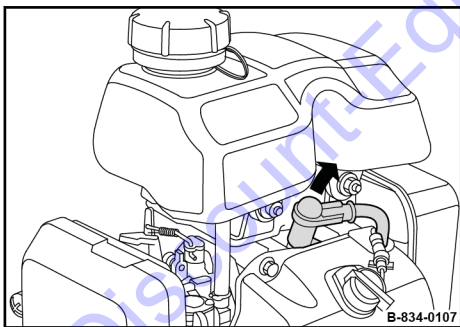

Fig. 80

1. For all maintenance work park the machine in secured condition ↪ *Chapter 6.6 „Parking the machine in secured condition“ on page 74.*
2. Pull off the spark plug socket.
3. Allow the machine to cool down.
4. Thoroughly clean the machine and engine before starting maintenance work.
5. After maintenance work has been completed, dispose of fuels and lubricants, filters, sealing elements and cleaning cloths in line with environmental regulations.
6. After maintenance work is completed reinstall all protective devices.
7. After all maintenance work is completed, plug the spark plug socket back on.

8.2 Fuels and lubricants

8.2.1 Engine oil

8.2.1.1 Oil quality

The following engine oil specifications are permitted:

- Engine oils for four-stroke engines acc. to API-classification SJ or higher

Avoid mixing of engine oils.

8.2.1.2 Oil viscosity

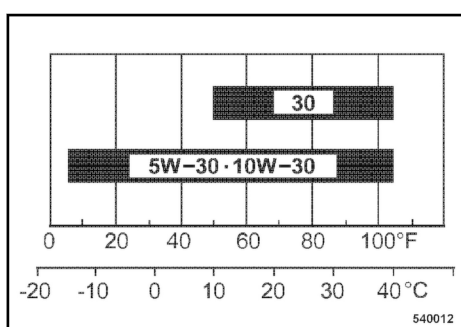

Fig. 81

Since engine oil changes its viscosity with the temperature, the ambient temperature at the operating location of the engine is of utmost importance when choosing the viscosity class (SAE-class).

The temperature data of the SAE-class always refers to fresh oils. In travel operation engine oil ages because of soot and fuel residues. This adversely affects the properties of the engine oil, especially under low ambient temperatures.

SAE 10W-30 is recommended for general use.

You may alternatively use 15W-40 (except under low temperatures).

8.2.1.3 Oil change intervals

Oil change interval: semi-annually or every 100 operating hours.

8.2.2 Fuel

8.2.2.1 Fuel quality

Use unleaded gasoline with a research octane number of 91 or higher (or octane number 86 or higher).

Use unleaded standard grade gasoline with maximum 10 percent by volume of ethanol (E10) or maximum 5 percent by volume of methanol.

Methanol must also contain co-solvents and corrosion inhibitors.

Do not use any fuel with a higher ethanol or methanol content.

The use of fuels with a higher ethanol or methanol content will cause starting and/or power problems or even cause damage in the fuel system.

8.2.2.2 Fuel stabilizer

If the machine is only occasionally used (if it is out of use for longer than four weeks), mix in the correct amount of fuel stabilizer directly after you have purchased fresh fuel.

The fuel stabilizer has a limited shelf life.

Please follow the instructions of the manufacturer concerning the correct mixing ratio and shelf life.

Mixing in fuel stabilizer does not regenerate old fuel.

Go to Discount-Equipment.com to order your parts

8.3 List of fuels and lubricants

Assembly group	Fuel or lubricant		Spare parts number	Filling quantity
	Summer	Winter		Observe the level mark!
Engine oil	SAE 10W-30 Specification: ↪ Chapter 8.2.1 „Engine oil“ on page 87			0.4 l (0.1 gal us)
	SAE 30			
Fuel	Gasoline (unleaded) Specification: ↪ Chapter 8.2.2 „Fuel“ on page 87			0.8 l (0.2 gal us)
	Fuel stabilizer Specification: ↪ Chapter 8.2.2.2 „Fuel stabilizer“ on page 88			

Go to Discount-Equipment.com to order your parts

Maintenance – Maintenance Table

8.4 Maintenance Table

No.	Maintenance works	Page
Running-in instructions		
8.5.1	General	91
8.5.2	After 25 operating hours	91
Monthly		
8.6.1	Air filter maintenance	92
Semi-annually		
8.7.1	Changing the engine oil	93
Annually		
8.8.1	Checking, adjusting the valve clearance	94
8.8.2	Replacing the spark plug	98
8.8.3	Replacing the fuel strainer	99
8.8.4	Replacing the starter rope	100
8.8.5	Replacing the air filter	102
8.8.6	Replacing the V-belt	103
As required		
8.9.1	Cleaning the cooling fins and the cooling air intake openings	106
8.9.2	Cleaning the machine	107
8.9.3	Cleaning, checking the spark plug, replacing if necessary	108
8.9.4	Checking, adjusting the engine speed	110
8.9.5	Measures for longer shut-down periods	112

8.5 Running-in instructions

8.5.1 General

The following maintenance work must be performed when running in new machines or overhauled engines.

Contact our customer service to carry out the required maintenance work.

8.5.2 After 25 operating hours

1. Change the engine oil ↪ *Chapter 8.7.1 „Changing the engine oil“ on page 93.*
2. Check engine and machine for leaks.
3. Retighten the fastening screws on air filter, exhaust and other attachments.
4. Retighten the bolted connections on the machine.
5. Check the V-belt.

8.6 Monthly

8.6.1 Air filter maintenance



If the engine loses power or running characteristics get worse, check the air filter and replace it if necessary.



NOTICE!

Danger of engine damage!

- Never start the engine after removing the air filter.
- Do not let dirt drop into the air duct.
- Do not continue using a damaged or soiled air filter. If in doubt use a new air filter.
- Replace the air filter after a year or 300 operating hours at the latest.

Protective equipment: ■ Working clothes
■ Safety shoes
■ Protective gloves

1. Park the machine safely ↪ *Chapter 6.6 „Parking the machine in secured condition“ on page 74.*
2. Let the machine and the engine cool down to ambient temperature.
3. Unscrew fastening screws (4) and remove cover (3).
4. Remove the foam rubber insert (2) from the cover.
5. Take the paper insert (1) out of the housing.
- 6.

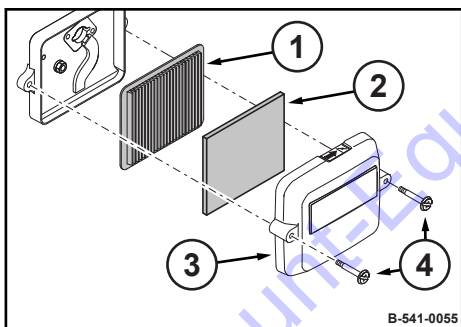

Fig. 82



NOTICE!

Danger of engine damage!

- Ensure that no dirt falls into the air duct.

Wipe the inside of the housing only with a lint-free, clean cloth.

7. Replace damaged or soiled paper insert.
8. Clean the foam rubber insert in warm soapsuds, rinse and dry thoroughly.
Do not apply any oil to the foam rubber insert.
9. Attach the foam rubber insert to the cover.
10. Fasten the paper insert and cover to the housing and tighten the fastening screws, tightening torque: 2.3 Nm (1.7 ft-lbf).

8.7 Semi-annually

8.7.1 Changing the engine oil



Perform this maintenance work at the latest after 100 operating hours



NOTICE!

Danger of engine damage!

- Change the oil only with the engine at operating temperature.
- Use only oil of the permitted specification ↪ Chapter 8.2.1 „Engine oil“ on page 87.
- Filling quantity: ↪ Chapter 8.3 „List of fuels and lubricants“ on page 89

Protective equipment: ■ Working clothes
■ Protective gloves

1. Park the machine in secured condition ↪ Chapter 6.6 „Parking the machine in secured condition“ on page 74.
2. Clean the area around the filler opening (2) and drain plug (3).
3. Unscrew the oil dipstick (1).

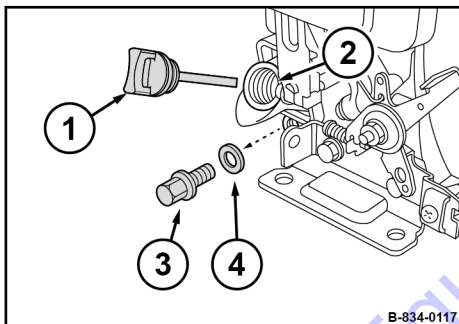

Fig. 83



WARNING!

Danger of burning on hot components!

- Wear your personal protective equipment (protective gloves, protective clothing).
- Avoid touching hot components.

Unscrew the drain plug and catch any oil running out.

5. Clean the oil drain plug and screw it back in with a new seal ring (4).
6. Fill in fresh oil up to the bottom edge of the filler opening (2).
7. Screw the oil dipstick (1) in.
8. Check for leaks after a short test run.
9. Check the oil level on the dipstick, correct if necessary.
10. Dispose of oil in an environmentally friendly way.

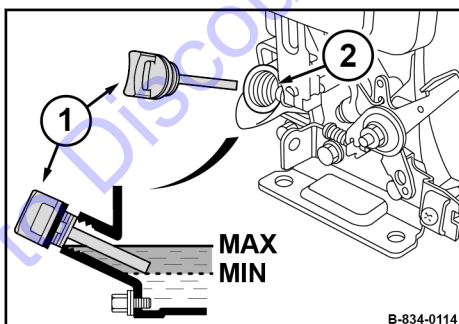

Fig. 84

8.8 Annually

8.8.1 Checking, adjusting the valve clearance



Perform this maintenance work at the latest after 200 operating hours.



NOTICE!

Danger of engine damage!

We recommend to have this work carried out by trained personnel or our after sales service.

- Before checking the valve clearance let the engine cool down.

Valve clearance:

Intake valve (IN)	0.15 mm (0.006 in)
Exhaust valve (EX)	0.20 mm (0.008 in)

Protective equipment: ■ Working clothes
■ Protective gloves

Preparations

1. Park the machine in secured condition ↪ *Chapter 6.6 „Parking the machine in secured condition“ on page 74.*
2. Let the machine and the engine cool down to ambient temperature.
3. Drain the fuel.

Removing the fuel tank



WARNING!

Health hazard caused by contact with gasoline!

- Wear your personal protective outfit (protective gloves, protective clothing).
- Do not inhale any fuel fumes.
- Do not swallow gasoline.
- Avoid contact with gasoline.

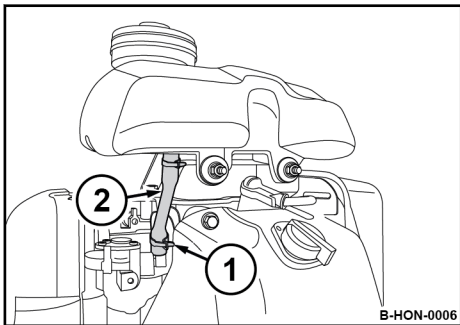

Fig. 85

4. Loosen the hose clamp (1) and pull off the fuel hose (2).

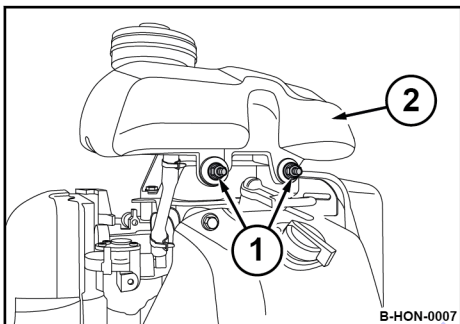

Fig. 86

5. Unscrew two fastening nuts (1) and remove the fuel tank (2).

Removing the valve cover

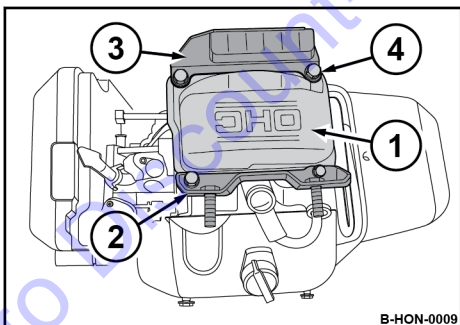

Fig. 87

6. Remove four fastening screws (4).
7. Remove valve cover (1) and holding fixtures (2, 3).

Checking, adjusting the valve clearance

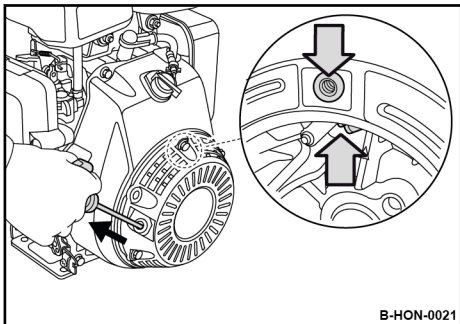

Fig. 88

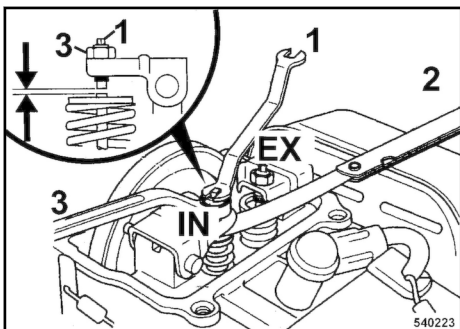

Fig. 89

Installing the valve cover

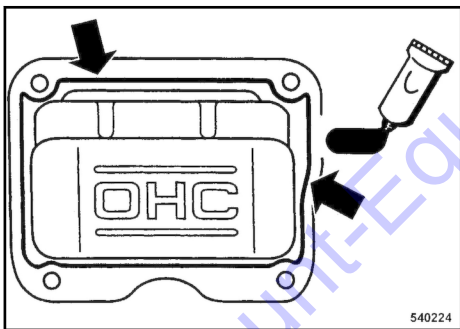

Fig. 90

8. Close valves:

For this slowly pull the starter handle, until resistance can be felt and the notch on the flywheel is aligned with the bore on the top side of the fan cover.

9. Slowly guide the starter handle back.

10. Check the valve clearance on the intake valve (IN) with a feeler gauge (2).

11. To adjust the valve hold the adjustment screw (1) and loosen locking nut (3).

Adjust the valve clearance with the adjustment screw.

Retighten the locking nut, tightening torque: 8 Nm (6 ft·lbf).

12. Check the valve clearance on the exhaust valve (EX).

13. Clean the sealing surfaces of valve cover and cylinder block.

14. Apply a bead of liquid sealant of approx. 1.5 to 2.0 mm (0.06 to 0.08 in) in diameter to the inner side of the cylinder head cover.



Liquid sealant: Three Bond 1207B or similar.

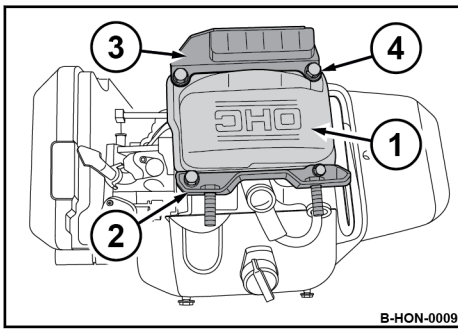

Fig. 91

Installing the fuel tank

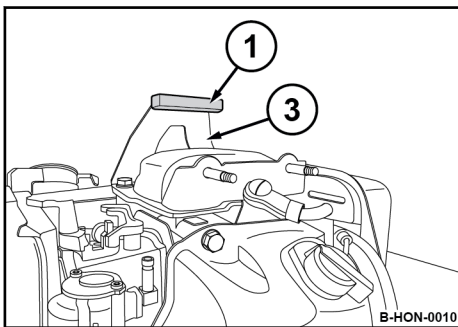

Fig. 92

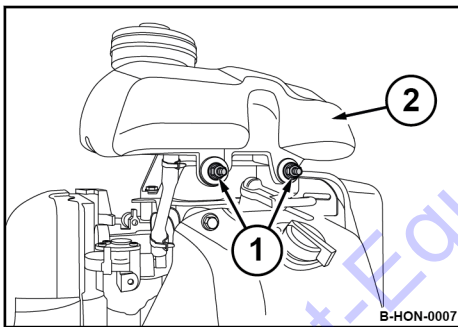

Fig. 93

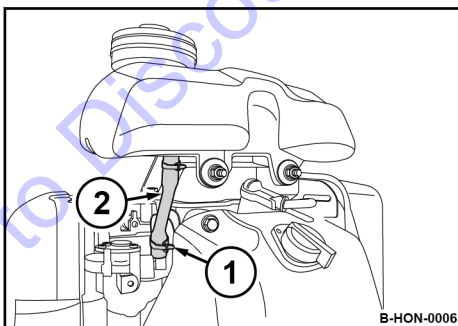

Fig. 94

Final work

- 15. Attach the valve cover (1) to the cylinder block within the next 10 minutes.
- 16. Fasten the valve cover and holding fixture (2, 3) with four fastening screws (4).

- 17. Attach the rubber (1) to the holding fixture (3).

- 18. Attach the fuel tank (2) and secure it with fastening nuts (1).

- 19. Fasten the fuel hose (2) with the hose clamp (1).

- 20. Wait another 20 minutes before starting the engine.

21. After a short test run check the engine for leaks.

8.8.2 Replacing the spark plug



NOTICE!

Danger of engine damage!

- Do not use spark plugs with incorrect heat value.

Recommended spark plugs:

NGK

CR5HSB

DENSO

U16FSR-UB

- Protective equipment:
- Working clothes
 - Safety shoes
 - Protective gloves

Special tool: ■ 16 mm spark plug spanner

1. Park the machine safely ↪ Chapter 6.6 „Parking the machine in secured condition“ on page 74.
2. Let the engine cool down to ambient temperature.
3. Clean the area around the spark plug.
4. Remove the spark plug using the spark plug spanner.

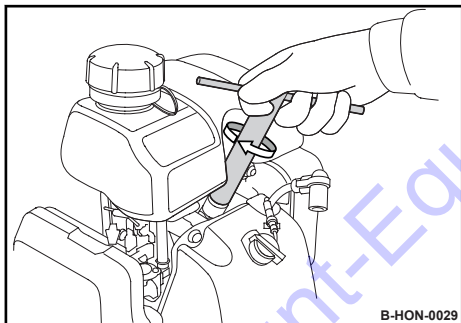

Fig. 95

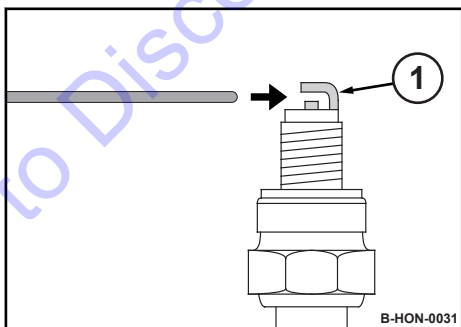

Fig. 96

5. Check the electrode gap of the new spark plug with a feeler gauge, if necessary, adjust the gap.
⇒ **Nominal value:** 0.6 - 0.7 mm (0.024 - 0.028 in)
6. To set the electrode distance carefully bend the electrode (1).
7. Carefully screw in the spark plug by hand.
8. Once the sealing ring of the new spark plug is in contact, tighten for another 1/2 turn with the spark plug spanner.

8.8.3 Replacing the fuel strainer



DANGER!

Danger to life caused by explosive gas-air mixes!

- Do not allow gasoline to come into contact with hot components.
- Smoking and open fire is prohibited.
- Keep away from heat sources, sparks and other sources of ignition.
- Do not spill any gasoline.



WARNING!

Health hazard caused by contact with gasoline!

- Wear your personal protective outfit (protective gloves, protective clothing).
- Do not inhale any fuel fumes.
- Do not swallow gasoline.
- Avoid contact with gasoline.

Protective equipment: ■ Working clothes
 ■ Safety shoes
 ■ Protective gloves

1. Park the machine safely ↪ Chapter 6.6 „Parking the machine in secured condition“ on page 74.
2. Allow the engine to cool down.
3. Drain the fuel.
4. Loosen the hose clamp (1) and pull off the fuel hose (2).
- 5.

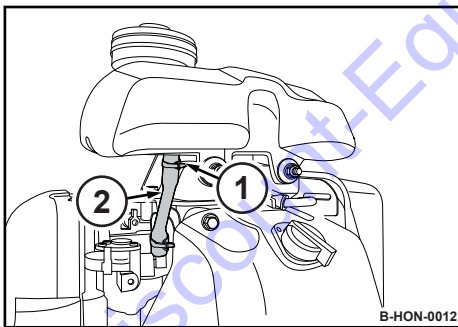

Fig. 97



*The fuel strainer is located in the fuel hose.
 When pulling off the fuel hose, the fuel strainer is also pulled out of the fuel tank.*

Maintenance – Annually

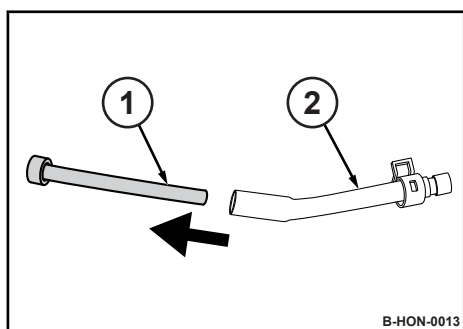

Fig. 98

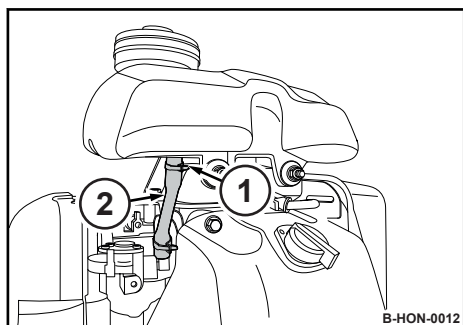

Fig. 99

6. Pull the fuel strainer (1) out of the fuel hose (2) and replace it.
7. Insert the fuel strainer back into the fuel hose.

8. Attach the fuel hose (2) and secure it with a hose clamp (1).
9. Fill in fuel.

8.8.4 Replacing the starter rope

Protective equipment: ■ Working clothes
■ Protective gloves

1. Park the machine in secured condition *↪ Chapter 6.6 „Parking the machine in secured condition“ on page 74.*
2. Allow the engine to cool down.
3. Disassembling the recoil starter.

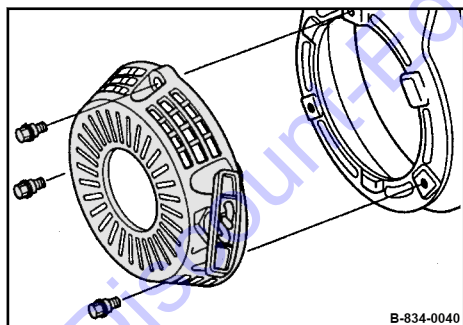

Fig. 100

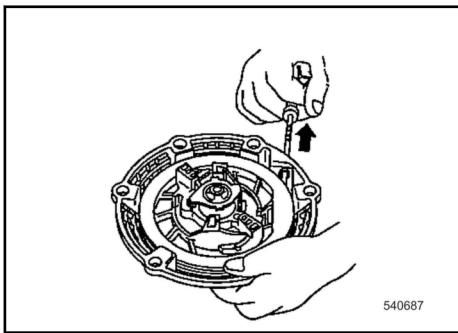

Fig. 101

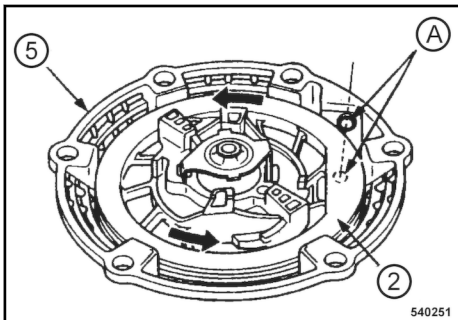

Fig. 102

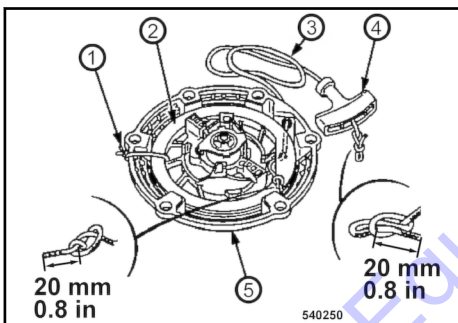

Fig. 103

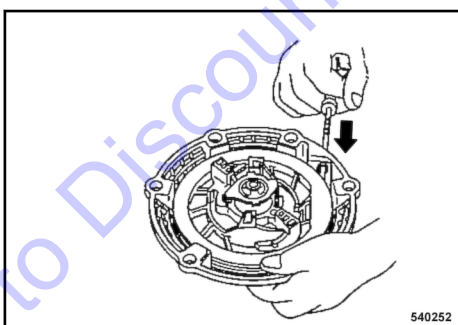

Fig. 104

4. Pull the starter rope with the starter handle out completely.

5. If the starter rope has been torn or the coil has recoiled completely:

- Before assembling the rope, turn the coil (2) 5 revolutions in anti-clockwise direction and align the rope openings in coil and housing (5) to one another (A).

6. Secure the coil against winding up. For this purpose tie the coil (2) to the housing (5) with a cable strap (1).

7. Untie the knots of the starter rope at both ends and remove the old starter rope.

8. Thread in the new starter rope (3) and fix it with knots on both ends.

- 9.



CAUTION!

Danger of injury caused by the starter handle hitting against your body!

- Do not let the starter handle hit back.

Remove the fixing of the coil and run the starter handle slowly back to initial position.

10. Pull the starter handle to check the function and light movement of the recoil starter.

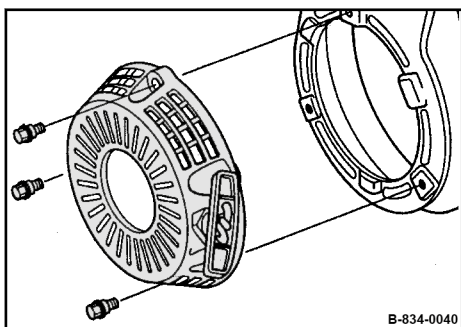

Fig. 105

11. Assemble the recoil starter.

8.8.5 Replacing the air filter



NOTICE!

Danger of engine damage!

- Do not start the engine after having removed the air filter.

Protective equipment: ■ Working clothes
 ■ Safety shoes
 ■ Protective gloves

1. Park the machine safely ☞ *Chapter 6.6 „Parking the machine in secured condition“ on page 74.*
2. Unscrew fastening screws (4) and remove cover (3).
3. Remove the foam rubber insert (2) from the cover.
4. Take the paper insert (1) out of the housing.
- 5.

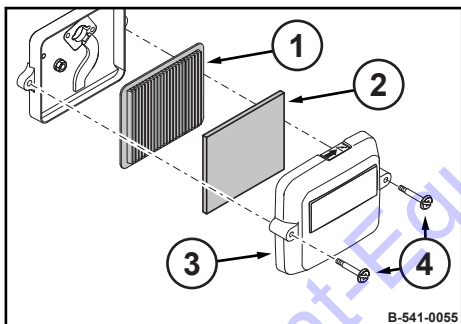

Fig. 106



NOTICE!

Danger of engine damage!

- Ensure that no dirt falls into the air duct.

Wipe the inside of the air filter housing with a clean cloth.

6. Replace paper element and foam element.
7. Attach the foam rubber insert (2) to the cover (3).
8. Fasten the paper insert (1) and cover to the housing and tighten the fastening screws (4), tightening torque: 2.3 Nm (1.7 ft·lbf).

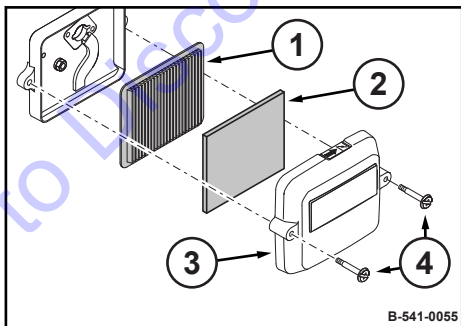

Fig. 107

8.8.6 Replacing the V-belt

- Protective equipment:
- Working clothes
 - Safety shoes
 - Protective gloves

1. Park the machine safely ↪ Chapter 6.6 „Parking the machine in secured condition“ on page 74.
2. Let the machine and the engine cool down to ambient temperature.
3. Unscrew the fastening screws (2) and remove the V-belt guard (1).

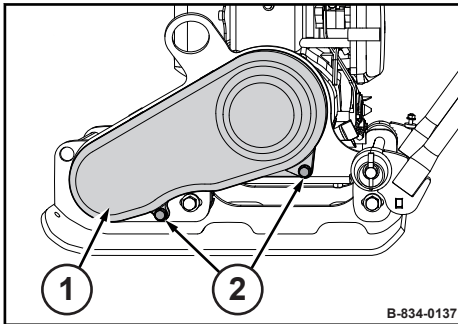

Fig. 108

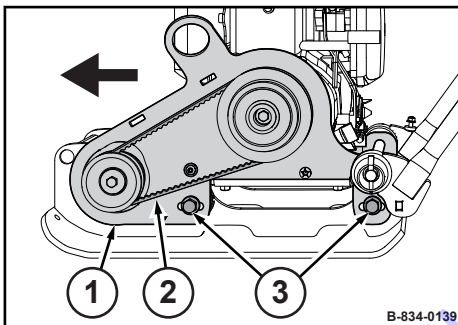

Fig. 109

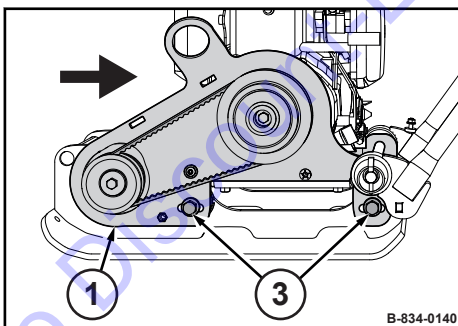

Fig. 110

4. Loosen the fastening screws (3) on both sides.
5. Pull the engine carrier (1) forward, remove and replace the V-belt (2).
6. Install the new V-belt and pull the engine carrier back.
7. Tighten the fastening screws (3) on both sides.

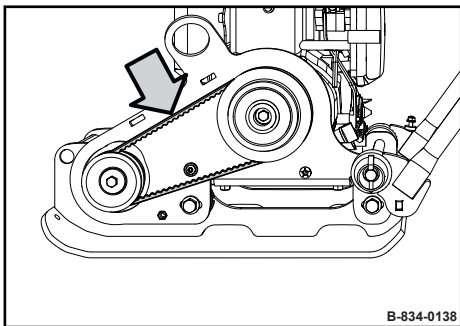

Fig. 111

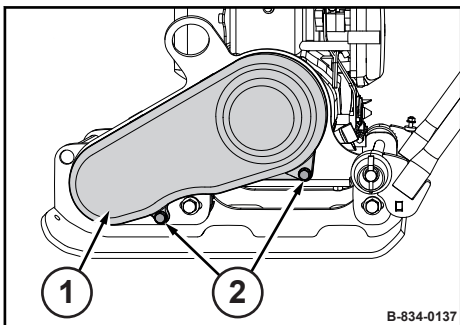

Fig. 112

8. Check tension of V-belt, tighten if necessary.
⇒ **Compression measurement:** approx. 5 mm (0.2 in).

9. Attach the V-belt guard (1) with the fastening screws (2).
10. Check the V-belt tension again after 25 operating hours, tighten if necessary.

8.8.6.1 Checking the frequency of the base plate

Keep feet and hands clear of the vibrating base plate.



CAUTION!

Danger of injury caused by uncontrolled machine movement!

- Always hold on to a running machine.
- Always keep an eye on a running machine.

Protective equipment: ■ Working clothes
■ Hearing protection
■ Safety shoes

Special tool: ■ Sirometer

1. Park the machine on a rubber mat.
2. Start the engine ↪ Chapter 6.4 „Starting the engine“ on page 67.
3. Run the machine at maximum speed for one minute.
4. Check the base plate's frequency with a suitable measuring instrument (e.g. Sirometer).
⇒ **Nominal value:** ↪ Chapter 2 „Technical data“ on page 11
5. Park the machine safely ↪ Chapter 6.6 „Parking the machine in secured condition“ on page 74.

6. If frequency incorrect:
 - Check the engine speed.
 - Check the V-belt.
 - If necessary, contact our customer service.

Go to Discount-Equipment.com to order your parts

8.9 As required

8.9.1 Cleaning the cooling fins and the cooling air intake openings



How dirty the cooling fins and cooling air intake openings are depends very much on the daily operating conditions; clean daily if necessary.



NOTICE!

Danger of engine damage caused by reduced cooling!

- For this reason you should always seal any oil or fuel leaks in the vicinity of the cooling fan or the coolers and clean the cooling fins after.

Protective equipment: ■ Working clothes
■ Protective gloves
■ Safety goggles

1. Park the machine in secured condition ↪ Chapter 6.6 „Parking the machine in secured condition“ on page 74.
2. Allow the engine to cool down.
3. Remove dried dirt with a suitable brush from all cooling fins and cooling air intake openings.

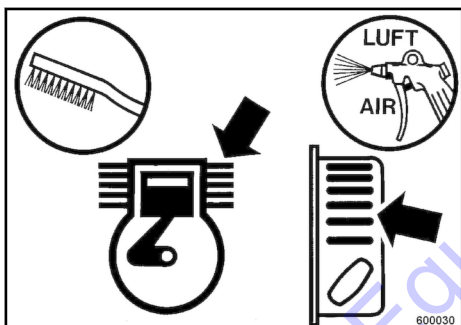

Fig. 113



CAUTION!

Danger of eye injuries caused by particles flying around!

- Wear your personal protective equipment (safety gloves, protective working clothes, goggles).

Blow out the cooling fins and cooling air intake openings with compressed air.

Cleaning with cold cleansing agent

If the engine is oily, use a cold cleansing agent for cleaning.



NOTICE!

Components can be damaged by water entering into the system!

- Do not direct the water jet directly into the air filter, carburettor, recoil starter, air intake or starter switch.

1.



CAUTION!

Danger of eye injuries caused by particles flying around!

- Wear your personal protective equipment (safety gloves, protective working clothes, goggles).

Spray the engine with a suitable, non-flammable cleansing agent, let it soak in for a while, clean it off with water and blow out with compressed air.

2. Warm up the engine for a while to avoid corrosion.
3. Look for the cause of oily contamination and have any leaks sealed by our customer service.

8.9.2 Cleaning the machine



NOTICE!

Danger of engine damage caused by reduced cooling!

- Immediately seal any oil or fuel leaks near fuel tank, cylinder or cooling air intake.

1. Park the machine in secured condition ↪ *Chapter 6.6 „Parking the machine in secured condition“ on page 74.*
2. Let the machine and the engine cool down to ambient temperature.

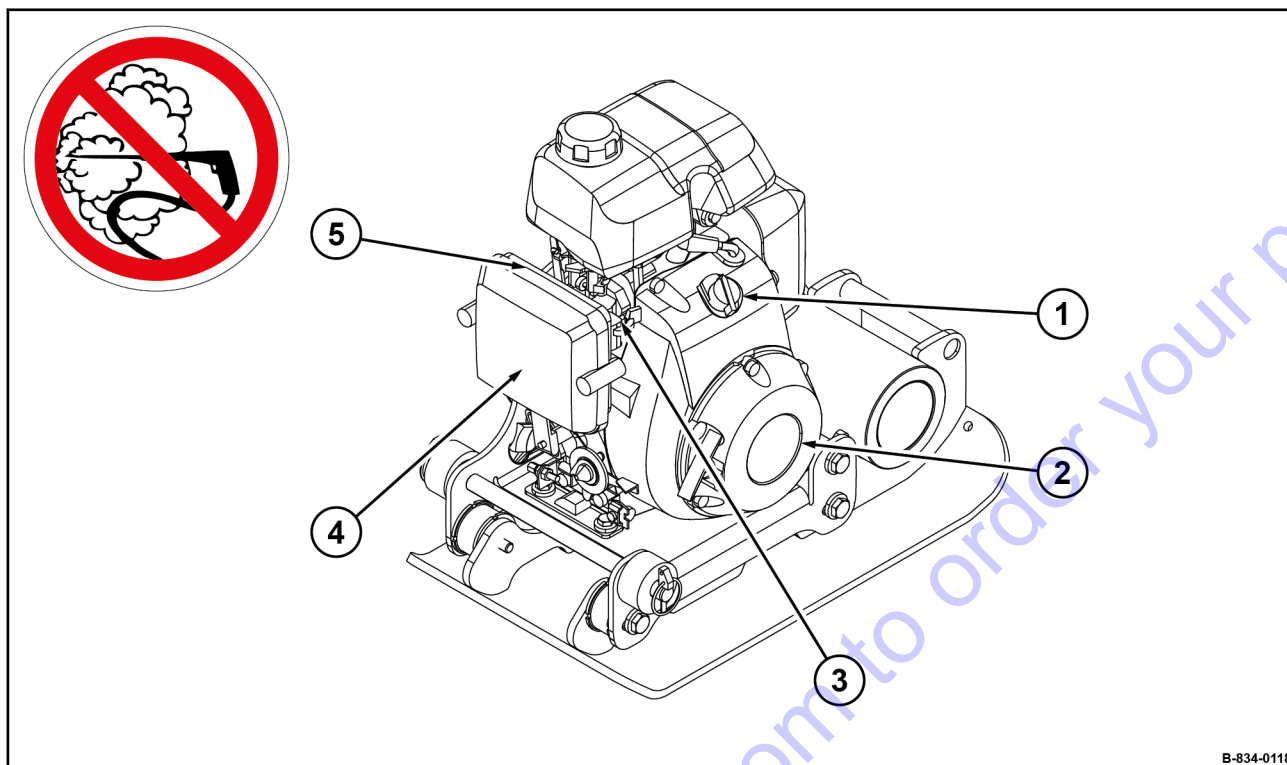

B-834-0118

Fig. 114

- 1 Starter switch
- 2 Recoil starter
- 3 Carburettor
- 4 Air filter
- 5 Air intake area



NOTICE!

Components can be damaged by water entering into the system!

- Do not direct the water jet directly into the air filter, carburettor, recoil starter, air intake or starter switch.

Clean the machine with a water jet.

4. Run the engine warm for a while to avoid corrosion.

8.9.3 Cleaning, checking the spark plug, replacing if necessary



NOTICE!

Danger of engine damage!

- Do not use spark plugs with incorrect heat value.

Recommended spark plugs:

NGK	CR5HSB
DENSO	U16FSR-UB

Protective equipment: ■ Working clothes
 ■ Safety shoes
 ■ Protective gloves

Special tool: ■ 16 mm spark plug spanner

1. Park the machine safely ↪ *Chapter 6.6 „Parking the machine in secured condition“ on page 74.*
2. Let the engine cool down to ambient temperature.
3. Clean the area around the spark plug.
4. Remove the spark plug using the spark plug spanner.

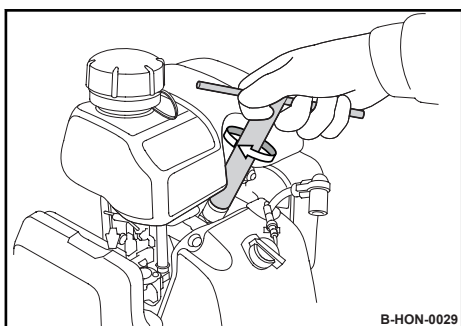

Fig. 115

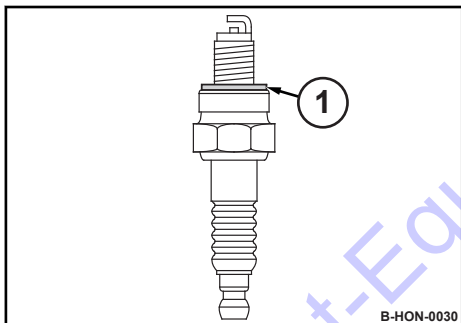

Fig. 116

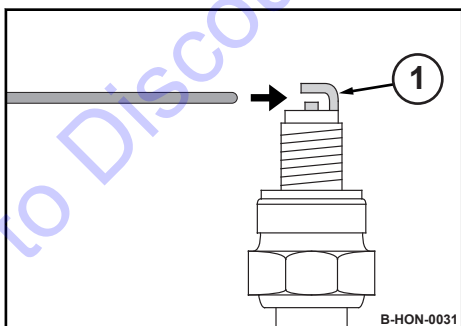

Fig. 117

5. Check the condition of the spark plug, replace if necessary ↪ *Chapter 8.8.2 „Replacing the spark plug“ on page 98.*
 ⇒ Replace the spark plug in the case of:
 - damages (e.g. cracks)
 - excessive combustion residues
 - burned off electrodes
 - worn or damaged seal ring (1)
6. Remove slight contamination with a wire brush.
7. Check the electrode gap with a feeler gauge.
 ⇒ **Nominal value:** 0.6 - 0.7 mm (0.024 - 0.028 in)
8. To set the electrode distance carefully bend the electrode (1).
9. Carefully screw in the spark plug by hand.
10. Once the seal ring of the used spark plug is in contact, tighten for another 1/8 to 1/4 turn with the spark plug spanner.

8.9.4 Checking, adjusting the engine speed

8.9.4.1 Checking the engine speed

Exhaust fumes contain toxic substances and can damage your health, cause unconsciousness or even death.



WARNING!

Danger of poisoning by exhaust gases!

- Do not inhale exhaust gases.
- Avoid operation in closed or partly closed rooms, or ensure adequate ventilation when working in trenches.



WARNING!

Loss of hearing caused by too high noise burdens!

- Wear your personal protective equipment (ear protection).

Nominal values:

Idle speed	1250 - 1350 min ⁻¹
Maximum engine speed	3600 to 3700 min ⁻¹

Protective equipment: ■ Hearing protection

■ Working clothes

■ Protective gloves

■ Safety shoes

Special tool: ■ Electronic tachometer

Prerequisites:

- Replaced air filter ↪ *Chapter 8.6.1 „Air filter maintenance“ on page 92.*
- Engine oil level checked ↪ *Chapter 5.3 „Checking the engine oil level“ on page 53.*

1. Start the engine ↪ *Chapter 6.4 „Starting the engine“ on page 67.*
2. Allow the engine to warm up for approx. 15 minutes.
3. Run the machine on a rubber mat.

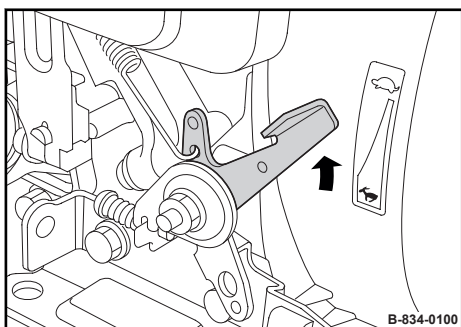

Fig. 118

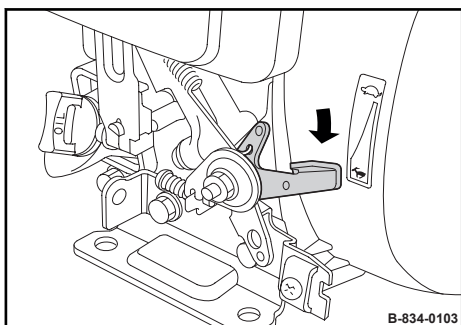

Fig. 119

8.9.4.2 Adjusting the engine speed

4. Set the throttle lever to position “MIN”.
5. After approx. 30 to 40 seconds check the idle speed using an electronic tachometer.

6. Set the throttle lever to “MAX” position.
7. After approx. 30 to 40 seconds check the maximum engine speed using an electronic tachometer.
8. If necessary, adjust the idle speed or maximum engine speed as required.



WARNING!

Danger of burning on hot components!

- Wear your personal protective equipment (protective gloves, protective clothing).
- Avoid touching hot components.

Protective equipment: ■ Working clothes
 ■ Protective gloves

1. Park the machine in secured condition ↗ Chapter 6.6 „Parking the machine in secured condition“ on page 74.
2. Let the engine to cool down to ambient temperature.
3. Adjust the engine idle speed with the adjustment screw (1).

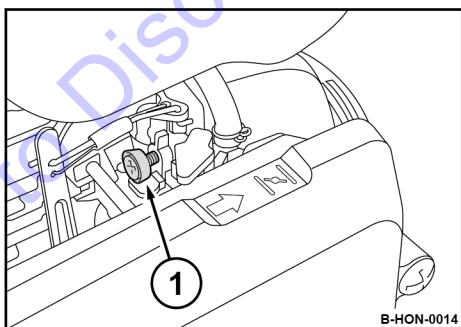

Fig. 120

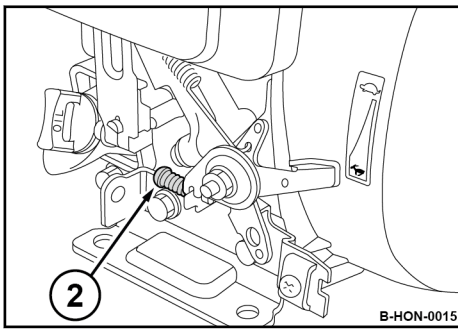

Fig. 121

4. Adjust the maximum engine speed with the adjustment screw (2).

8.9.5 Measures for longer shut-down periods

8.9.5.1 Measures before shutting down



DANGER!

Danger to life caused by explosive gas-air mixes!

- Do not allow gasoline to come into contact with hot components.
- Smoking and open fire is prohibited.
- Keep away from heat sources, sparks and other sources of ignition.
- Do not spill any gasoline.

If the machine is shut down for a longer period of time, e.g. winter season, the following work must be carried out.

Depending on weather conditions these conservation measures will protect the machine for approx. 6 to 12 months.

1. Park the machine in secured condition ↪ *Chapter 6.6 „Parking the machine in secured condition“ on page 74.*
2. Allow the engine to cool down for at least 30 minutes.
3. Clean the machine thoroughly.
4. Change the engine oil ↪ *Chapter 8.7.1 „Changing the engine oil“ on page 93.*
5. Use fuel stabilizer.

Using fuel stabilizer



Alternatively, drain the fuel tank completely.

1. Mix fresh fuel with fuel stabilizer (follow the instructions of the manufacturer).
2. Empty the fuel tank and fill it with the prepared fuel mix.
3. Start the engine and run the machine for approx. 10 minutes in the open.

4. Park the machine in secured condition.

Protecting the cylinder

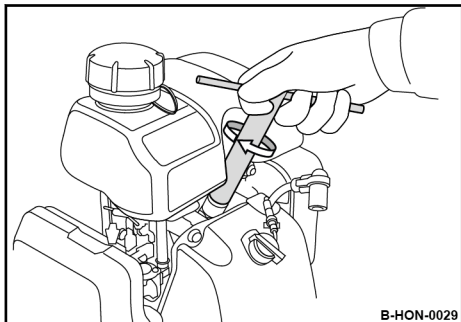

Fig. 122

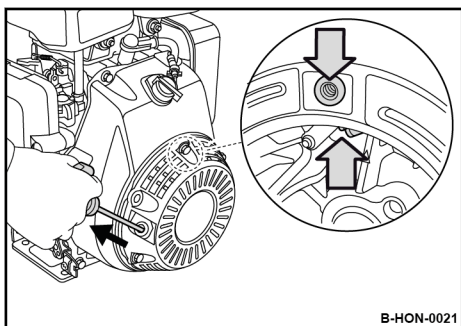

Fig. 123

Parking the machine

- Special tool: ■ 16 mm spark plug spanner
1. Clean the area around the spark plug.
 2. Remove the spark plug using the spark plug spanner.
 3. Fill in several drops of fresh engine oil through the ignition plug opening.
 4. Crank the engine several times with the recoil starter to distribute the oil in the cylinder.
 5. Screw the spark plug back in.
 6. For this, slowly pull the starter rope, until resistance can be felt and the notch on the flywheel is aligned with the bore on the top side of the fan cover.
 - ⇒ Valves will be closed so that no moisture can enter into the cylinder.
 7. Slowly guide the starter rope back.
 1. After shutting down store the machine under cover in a dry and well ventilated room.
 2. Cover the engine to protect it against dust and moisture.
 3. A machine with conserved engine must be clearly marked by attaching an information sign.

8.9.5.2 Measures before restarting



DANGER!

Danger to life caused by explosive gas-air mixes!

- Do not allow gasoline to come into contact with hot components.
- Smoking and open fire is prohibited.
- Keep away from heat sources, sparks and other sources of ignition.
- Do not spill any gasoline.

Maintenance – As required

1. Check the oil levels.
2. If the fuel was drained off before shutting down, you must now fill in fuel.
3. Check hoses and lines for cracks and leaks.
4. Clean the machine thoroughly.
5. Start the engine and run it for 15 to 30 minutes with idle speed.

Go to Discount-Equipment.com to order your parts

Go to Discount-Equipment.com to order your parts

9.1 Preliminary remarks

Malfunctions are frequently caused by incorrect operation of the machine or insufficient maintenance. Whenever a fault occurs you should therefore thoroughly read these instructions on correct operation and maintenance.

If you cannot locate the cause of a fault or rectify it yourself by following the trouble shooting chart, you should contact our customer service department.

Go to Discount-Equipment.com to order your parts

9.2 Engine malfunctions

Malfunction	Possible cause	Remedy
Engine does not start	Fuel valve closed	Open the fuel cock.
	Set the starter switch to position "OFF".	Set the starter switch to position "ON".
	Choke open	When the engine is cold, close the choke lever.
	Fuel tank empty	Check, fill up if necessary.
	Fuel system clogged	Have it checked by our customer service.
	Ignition malfunction	Have it checked by our customer service.
	Carburettor malfunction	Have it checked by our customer service.
	Jammed valves	Have it checked by our customer service.
Engine does not crank when operating the recoil starter	Recoil starter defective	Have the recoil starter replaced by our customer service.
	Spring broken	Have the recoil starter replaced by our customer service.
Starter rope of recoil starter does not return to initial position	Recoil starter dirty	Have the recoil starter checked by our customer service.
	Insufficient pre-tension of the spring	Have the pre-tension of the spring checked by our customer service.
	Spring broken	Have the recoil starter replaced by our customer service.
Low engine power	Air filter clogged	Have it checked by our customer service.
	Fuel system clogged	Have it checked by our customer service.
	Ignition malfunction	Have it checked by our customer service.
	Carburettor malfunction	Have it checked by our customer service.
	Jammed valves	Have it checked by our customer service.
Engine overheats	Lack of cooling air	Have it checked by our customer service.
Engine runs with high speed, but no vibration	Centrifugal clutch defective	Have it replaced by our customer service.
	V-belt broken	Have it replaced by our customer service.

9.3 What to do if the engine has flooded

If the recoil starter is frequently operated with the choke closed and without the engine starting, the engine will draw in too much fuel and is unable to start.

Exhaust fumes contain toxic substances and can damage your health, cause unconsciousness or even death.



WARNING!

Danger of poisoning by exhaust gases!

- Do not inhale exhaust gases.
- Avoid operation in closed or partly closed rooms, or ensure adequate ventilation when working in trenches.



WARNING!

Loss of hearing caused by too high noise burdens!

- Wear your personal protective equipment (ear protection).

- Protective equipment:
- Working clothes
 - Hearing protection
 - Protective gloves
 - Safety shoes

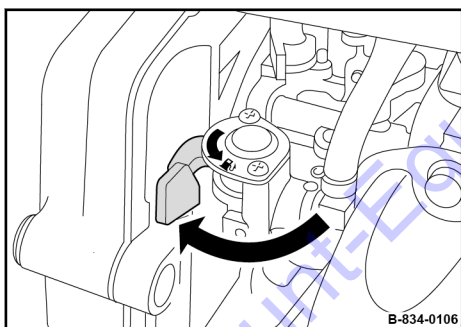

Fig. 124

1. Close the fuel valve.

Troubleshooting – What to do if the engine has flooded

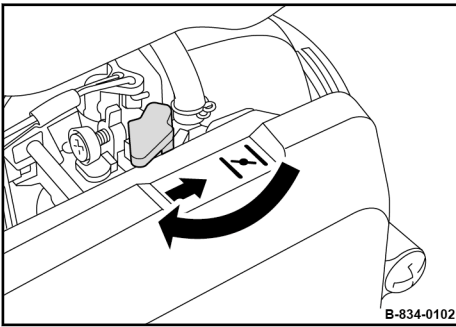

Fig. 125

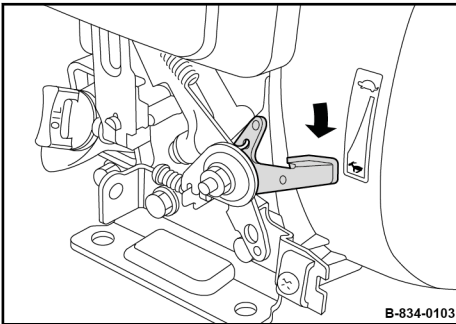

Fig. 126

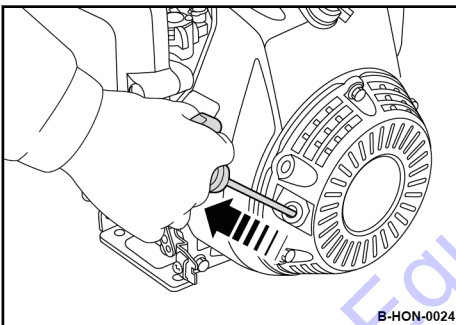

Fig. 127

2. Open the choke with the choke lever.

3. Set the throttle lever to position "MAX".

4.



CAUTION!

Danger of injury caused by uncontrolled machine movement!

- Always hold on to a running machine.
- Always keep an eye on a running machine.

Operate the recoil starter, until the engine starts.



If the engine still does not start after 10 to 20 attempts, clean the spark plug.

Troubleshooting – What to do if the engine has flooded

Cleaning the spark plug

- Protective equipment: ■ Working clothes
■ Protective gloves
■ Safety goggles
- Special tool: ■ 16 mm spark plug spanner



WARNING!

Danger of burning on hot components!

- Wear your personal protective equipment (protective gloves, protective clothing).
- Avoid touching hot components.

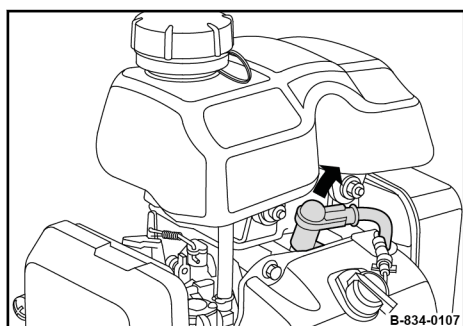

Fig. 128

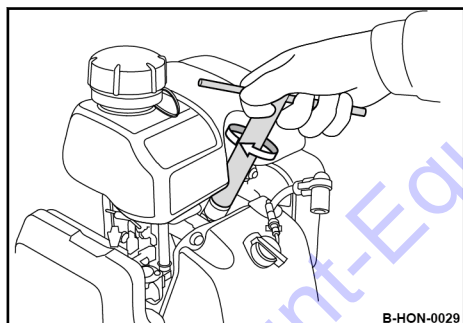

Fig. 129

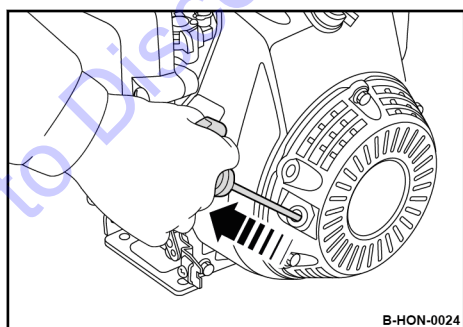

Fig. 130

1. Let the machine and the engine cool down to ambient temperature.
2. Pull off the spark plug socket.
3. Remove the spark plug using the spark plug spanner.
4. Operate the recoil starter several times.

Troubleshooting – What to do if the engine has flooded

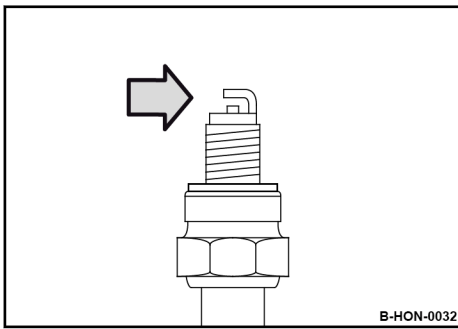

Fig. 131

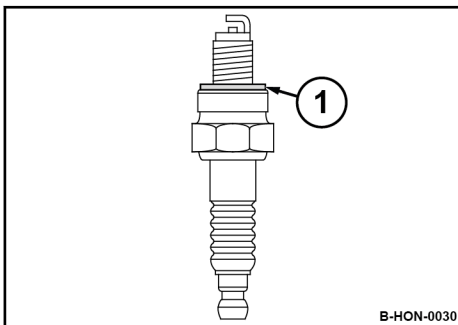

Fig. 132

5.



CAUTION!

Danger of eye injuries caused by particles flying around!

- Wear your personal protective equipment (safety gloves, protective working clothes, goggles).

Dry the spark plug with a clean cloth or blow it dry with compressed air.

6.

If necessary, clean the spark plug with a wire brush.

7.

Screw the spark plug carefully in by hand and once the seal (1) of the used spark plug makes contact, tighten for another 1/8 to 1/4 turn with the spark plug spanner.

8.

Plug the spark plug socket back on.

9.

Repeat the starting procedure ↪ Chapter 6.4 „Starting the engine“ on page 67.

Go to Discount-Equipment.com to order your parts

10.1 Final shut-down of machine

If the machine can no longer be used and needs to be finally shut down, you must have the following work carried out by our customer service and have the machine disassembled by an officially recognized recycling company.



DANGER!

Danger to life caused by explosive gas-air mixes!

- Do not allow gasoline to come into contact with hot components.
- Smoking and open fire is prohibited.
- Keep gasoline away from heat sources, sparks and other sources of ignition.
- Do not spill any gasoline.
- Components that previously contained gasoline must not be cut with a cutting torch.



WARNING!

Health hazard caused by fuels and lubricants!

- Safety regulations and environmental protection regulations must be followed when handling fuels and lubricants ↪ *Chapter 3.4 „Handling fuels and lubricants“ on page 25.*

Protective equipment: ■ Working clothes
■ Safety shoes
■ Protective gloves
■ Safety goggles

1. Empty the fuel tank.
2. Drain off engine oil.

Go to Discount-Equipment.com to order your parts

List of special tools

16 mm spark plug spanner

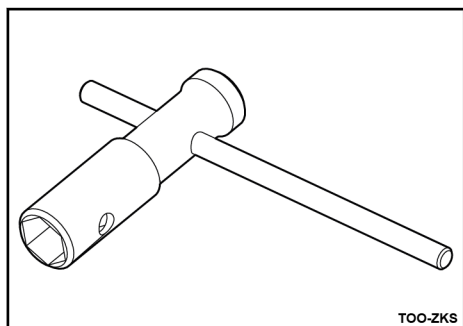

Fig. : 16 mm spark plug spanner
(example)

Electronic tachometer BOMAG 079 948 99

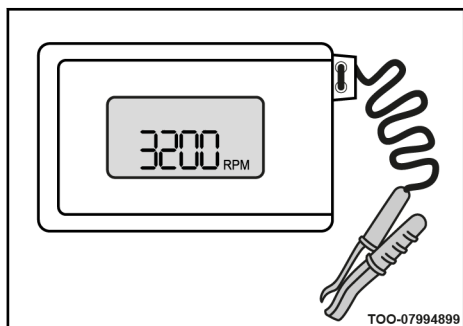

Fig.

Sirometer Measuring instrument for speed and frequency BOMAG 059 710 02

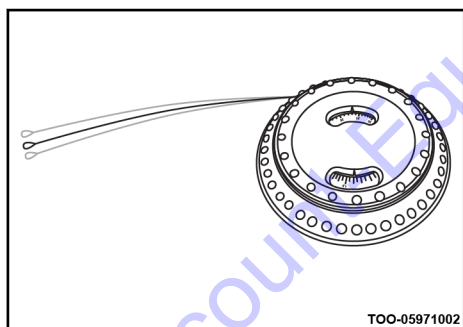

Fig.

12 Terminology

Centrifugal clutch

The centrifugal clutch causes the power only to be transmitted from the engine to the exciter system at higher engine speeds.

Danger zone

The danger zone is the area around the machine in which the safety or health of persons is at risk.

Lashing gear

Lashing gear is a flexible means for securing loads and includes tensioning tools, tensioning element and perhaps connecting elements, e.g. lashing belts, lashing chains, lashing wires.

The maximum permitted tensile force is marked on the lashing gear.

Lashing point

A lashing point is a safety facility on a transport vehicle or the machine, to which a piece of lashing gear can be fastened directly.

Lifting tackle

Lifting tackle is a flexible means for lifting, such as ropes, chains, lifting belts, belt slings, round slings and detachable connection parts (e.g. shackles, hooks).

The maximum permitted load bearing capacity is marked on the lifting tackle.

PARTS FINDER

**Search Website
by Part Number**



**Search Manual
Library For Parts
Manual & Lookup Part
Numbers – Purchase
or Request Quote**

Search Manuals

Enter your information to help us find the right parts manual for your machine.

* Brand:

* Model:

* Serial:

* Part Number:

SEARCH

**Can't Find Part or
Manual? Request Help
by Manufacturer,
Model & Description**

Parts Order Form

Please fill in the following information to help us find the right part for your machine.

Manufacturer:	<input type="text"/>
Model:	<input type="text"/>
Description:	<input type="text"/>
Part Number:	<input type="text"/>
Quantity:	<input type="text"/>
Notes:	<input type="text"/>

Discount-Equipment.com is your online resource for quality parts & equipment.

Florida: **561-964-4949** Outside Florida TOLL FREE: **877-690-3101**

Need parts?

Click on this link: <http://www.discount-equipment.com/category/5443-parts/> and choose one of the options to help get the right parts and equipment you are looking for. Please have the machine model and serial number available in order to help us get you the correct parts. If you don't find the part on the website or on one of the online manuals, please fill out the request form and one of our experienced staff members will get back to you with a quote for the right part that your machine needs.

We sell worldwide for the brands: Genie, Terex, JLG, MultiQuip, Mikasa, Essick, Whiteman, Mayco, Toro Stone, Diamond Products, Generac Magnum, Airman, Haulotte, Barreto, Power Blanket, Nifty Lift, Atlas Copco, Chicago Pneumatic, Allmand, Miller Curber, Skyjack, Lull, Skytrak, Tsurumi, Husquvarna Target, Stow, Wacker, Sakai, Mi-T-M, Sullair, Basic, Dynapac, MBW, Weber, Bartell, Bennar Newman, Haulotte, Ditch Runner, Menegotti, Morrison, Contec, Buddy, Crown, Edco, Wyco, Bomag, Laymor, EZ Trench, Bil-Jax, F.S. Curtis, Gehl Pavers, Heli, Honda, ICS/PowerGrit, IHI, Partner, Imer, Clipper, MMD, Koshin, Rice, CH&E, General Equipment, Amida, Coleman, NAC, Gradall, Square Shooter, Kent, Stanley, Tamco, Toku, Hatz, Kohler, Robin, Wisconsin, Northrock, Oztec, Toker TK, Rol-Air, APT, Wylie, Ingersoll Rand / Doosan, Innovatech, Con X, Ammann, Mecalac, Makinex, Smith Surface Prep, Small Line, Wanco, Yanmar



www.discount-equipment.com

Go to Discount-Equipment.com to order your parts