



BOMAG

FAYAT GROUP

Operating instructions Maintenance instructions

Original operating instructions

BT 60/4 / BT 65/4

S/N 101 540 57 1146 > / S/N 101 540 58 1237 >

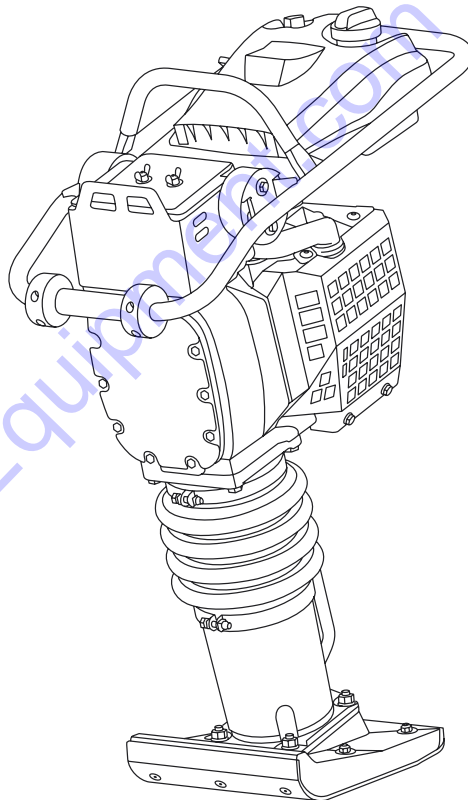

Vibratory Tamper



www.discount-equipment.com

PARTS FINDER

**Search Website
by Part Number**



**Search Manual
Library For Parts
Manual & Lookup Part
Numbers – Purchase
or Request Quote**

**Can't Find Part or
Manual? Request Help
by Manufacturer,
Model & Description**

Discount-Equipment.com is your online resource for quality parts & equipment.

Florida: **561-964-4949** Outside Florida TOLL FREE: **877-690-3101**

Need parts?

Click on this link: <http://www.discount-equipment.com/category/5443-parts/> and choose one of the options to help get the right parts and equipment you are looking for. Please have the machine model and serial number available in order to help us get you the correct parts. If you don't find the part on the website or on one of the online manuals, please fill out the request form and one of our experienced staff members will get back to you with a quote for the right part that your machine needs.

We sell worldwide for the brands: Genie, Terex, JLG, MultiQuip, Mikasa, Essick, Whiteman, Mayco, Toro Stone, Diamond Products, Generac Magnum, Airman, Haulotte, Barreto, Power Blanket, Nifty Lift, Atlas Copco, Chicago Pneumatic, Allmand, Miller Curber, Skyjack, Lull, Skytrak, Tsurumi, Husquvarna Target, Stow, Wacker, Sakai, Mi-T-M, Sullair, Basic, Dynapac, MBW, Weber, Bartell, Bennar Newman, Haulotte, Ditch Runner, Menegotti, Morrison, Contec, Buddy, Crown, Edco, Wyco, Bomag, Laymor, EZ Trench, Bil-Jax, F.S. Curtis, Gehl Pavers, Heli, Honda, ICS/PowerGrit, IHI, Partner, Imer, Clipper, MMD, Koshin, Rice, CH&E, General Equipment, Amida, Coleman, NAC, Gradall, Square Shooter, Kent, Stanley, Tamco, Toku, Hatz, Kohler, Robin, Wisconsin, Northrock, Oztec, Toker TK, Rol-Air, APT, Wylie, Ingersoll Rand / Doosan, Innovatech, Con X, Ammann, Mecalac, Makinex, Smith Surface Prep, Small Line, Wanco, Yanmar

If the machine is equipped with a battery :

CALIFORNIA
Proposition 65 Warning

Battery posts, terminals and related accessories contain lead and lead compounds, chemicals known to the State of California to cause cancer and birth defects or other reproductive harm.
Wash hands after handling.

If the machine is equipped with a diesel engine :

CALIFORNIA
Proposition 65 Warning

The engine exhaust and some of its constituents are known to the state of California to cause cancer, birth defects, and other reproductive harm.

Go to Discount-Equipment.com to order your parts

1 Foreword

BOMAG manufactures machine for earth, asphalt and refuse compaction, stabilizers/recyclers as well as milling machine and finishers.

BOMAG's vast experience in connection with state-of-the-art production and testing methods, such as lifetime tests of all important components and highest quality demands guarantee maximum reliability of your machine.

This manual comprises:

- Safety regulations
- Operating instructions
- maintenance instructions
- Trouble shooting

Using these instructions will

- help you to become familiar with the machine.
- avoid malfunctions caused by unprofessional operation.

Compliance with the maintenance instructions will

- enhance the reliability of the machine on construction sites,
- prolong the lifetime of the machine,
- reduce repair costs and downtimes.

BOMAG will not assume liability for the function of the machine

- if it is handled in a way not complying with the usual modes of use,
- if it is used for purposes other than those mentioned in these instructions.

No warranty claims can be lodged in case of damage resulting from

- operating errors,
- insufficient maintenance and
- wrong fuels and lubricants.

Please note!

This manual was written for operators and maintenance personnel on construction sites.

These operating and maintenance instructions are part of the machine.

You should only operate the machine after you have been instructed and in compliance with these instructions.

Strictly observe the safety regulations.

Please observe also the guidelines of the Civil Engineering Liability Association "Safety Rules for the Operation of Road Rollers and Soil Compactors" and all relevant accident prevention regulations.

For your own personal safety you should only use original spare parts from BOMAG.

For your machine BOMAG offers service kits to make maintenance easier.

In the course of technical development we reserve the right for technical modifications without prior notification.

These operating and maintenance instructions are also available in other languages.

Apart from that, the spare parts catalogue is available from your BOMAG dealer against the serial number of your machine.

Your BOMAG dealer will also supply you with information about the correct use of our machines in soil and asphalt construction.

The above notes do not constitute an extension of the warranty and liability conditions specified in the general terms of business of BOMAG.

We wish you successful work with your BOMAG machine.

BOMAG GmbH

Copyright by BOMAG

Foreword

Please fill in

.....
Machine type(Fig. 1)

.....
Serial number (Fig. 2)

.....
Engine type (Fig. 3)

.....
Engine number (Fig. 3)

i Note

Supplement the above data together with the commissioning protocol.

During commissioning our organisation will instruct you in the operation and maintenance of the machine.

Please observe strictly the safety regulations and all notes on risks and dangers!

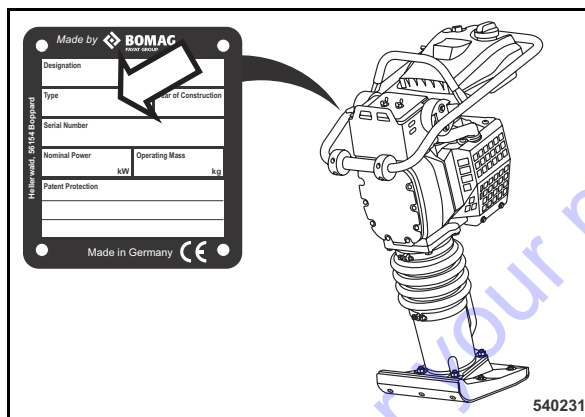

Fig. 1

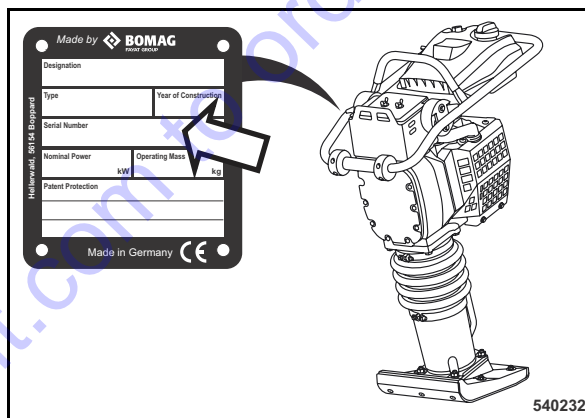

Fig. 2

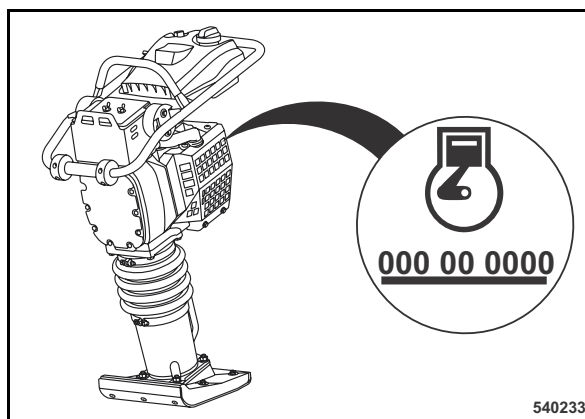

Fig. 3

1	Foreword	3
2	Technical Data	7
3	Safety regulations	13
4	Indicators and Controls	19
	4.1 General notes	20
	4.2 Description of indicators and control elements	20
5	Operation	23
	5.1 General	24
	5.2 Tests before taking into operation	24
	5.3 Adjusting the steering bow	25
	5.4 Starting the engine	25
	5.5 Work/operation	28
	5.6 Shutting down the engine	30
	5.7 Changing the tamper foot plate	31
	5.8 Loading/transport	31
6	Maintenance	33
	6.1 General notes on maintenance	34
	6.2 Fuels and lubricants	35
	6.3 Table of fuels and lubricants	36
	6.4 Running-in instructions	37
	6.5 Maintenance table	38
	Maintenance every day	39
	6.6 Clean the machine	39
	6.7 Check the engine oil level	39
	6.8 Check the fuel level	40
	Maintenance every month	41
	6.9 Change the engine oil	41
	6.10 Cleaning, checking the spark plug, replacing if necessary	42
	6.11 Check the tamper foot	43
	Maintenance every year	45
	6.12 Check, adjust the valve clearance	45
	6.13 Replace the fuel filter	47
	6.14 Cleaning the fuel screen	48
	6.15 Check, adjust the engine speed	50
	6.16 Replacing the starter rope	52
	6.17 Oil change in tamper foot	54
	As required	55

Table of Contents

6.18	Check, clean the air filter, replace if necessary	55
7	Trouble shooting	57
7.1	General notes	58
7.2	Engine problems	59
8	Disposal	61
8.1	Final shut-down of machine	62

Go to Discount-Equipment.com to order your parts

2 Technical Data

Technical Data

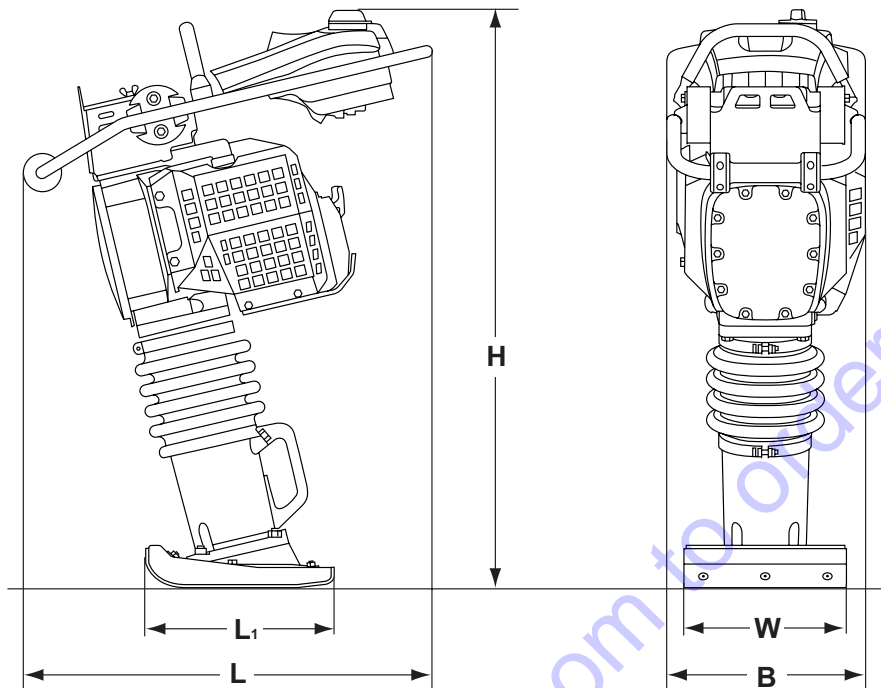

540234

Fig. 4

Dimensions in mm (in)	B	H	L	L1	W
BT 60/4	350 (13.8)	960 (37.8)	735 (28.9)	335 (13.2)	280 (11.0)

1

BT 60/4

Weight

Basic weight	kg (lbs)	61 (134)
Operating weight (CECE)	kg (lbs)	62 (137)

Travel characteristics

Max. working speed (depending on soil)	m/min (ft/min)	20 (66)
Max. areal output (depending on soil)	m ² /h (ft ² /h)	336 (3616)

Drive

Engine manufacturer		Honda
Type		GX 100
Cooling		Air
Number of cylinders		1
Displacement	cm ³	98

1			BT 60/4
Rated power ISO 9249		kW (hp)	2,3 (3.1)
Rated speed		min ⁻¹	4200
Exciter system			
Drive system			mechanical
Frequency		Hz	10 – 11.8
Impact force		kN (lbf)	13,5 (3035)
Filling capacities			
Fuel tank		l (gal us)	3,0 (0.80)
Oil in tamper foot		l (gal us)	0,75 (0.20)
Engine oil		l (gal us)	0,3 (0.08)

1 The right for technical modifications remains reserved

Go to Discount-Equipment.com to order your parts

Technical Data

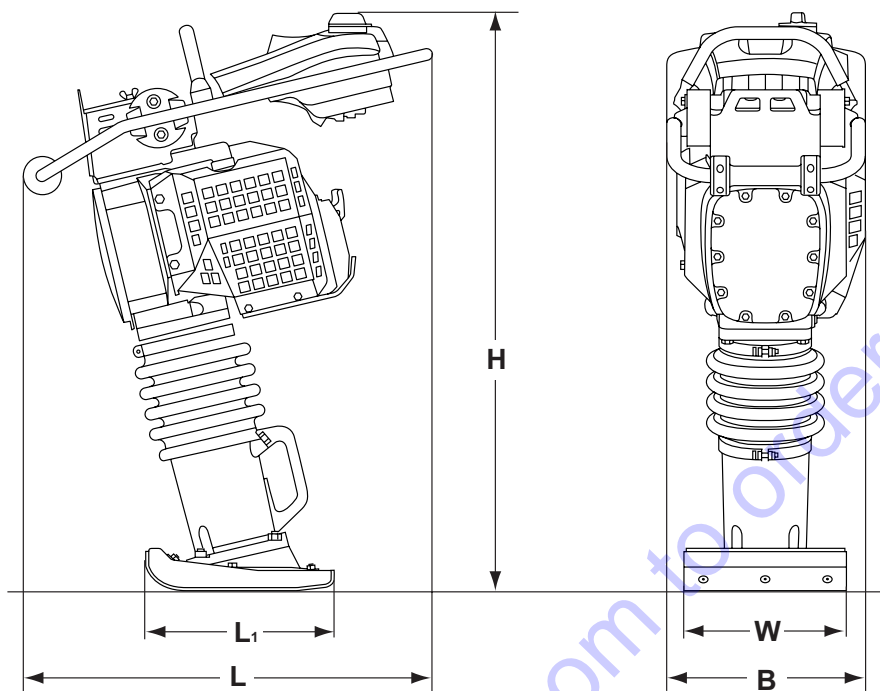

540234

Fig. 5

Dimensions in mm (in)	B	H	L	L1	W
BT 65/4	350 (13.8)	1000 (39.4)	735 (28.9)	335 (13.2)	280 (11.0)

1

BT 65/4

Weight

Basic weight	kg (lbs)	67 (148)
Operating weight (CECE)	kg (lbs)	68 (150)

Travel characteristics

Max. working speed (depending on soil)	m/min (ft/min)	20 (66)
Max. areal output (depending on soil)	m ² /h (ft ² /h)	336 (3616)

Drive

Engine manufacturer		Honda
Type		GX 100
Cooling		Air
Number of cylinders		1
Displacement	cm ³	98

1			BT 65/4
Rated power ISO 9249		kW (hp)	2,3 (3.1)
Rated speed		min ⁻¹	4200
Exciter system			
Drive system			mechanical
Frequency		Hz	10 – 11.8
Impact force		kN (lbf)	16,2 (3642)
Filling capacities			
Fuel tank		l (gal us)	3,0 (0.80)
Oil in tamper foot		l (gal us)	1,0 (0.26)
Engine oil		l (gal us)	0,3 (0.08)

1 The right for technical modifications remains reserved

Go to Discount-Equipment.com to order your parts

Technical Data

The following noise and vibration data acc. to

- EC Machine Regulation edition 2006/42/EC
- the noise regulation 2000/14/EG, noise protection guideline 2003/10/EC
- Vibration Protection Regulation 2002/44/EC

were determined during conditions typical for this type of equipment and by application of harmonized standards.

During operation these values may vary because of the existing operating conditions.

Noise value

Sound pressure level on the place of the operator:

BT 60/4: $L_{pA} = 94$ dB(A), determined acc. to ISO 11204 and EN 500

BT 65/4: $L_{pA} = 93$ dB(A), determined acc. to ISO 11204 and EN 500

Guaranteed sound power level:

BT 60/4: $L_{WA} = 108$ dB(A), determined acc. to ISO 3744 and EN 500

BT 65/4: $L_{WA} = 108$ dB(A), determined acc. to ISO 3744 and EN 500

Danger

Loss of hearing!

Wear your personal noise protection means (ear defenders) before starting operation.

Vibration value

Hand-arm vibration:

Vector total of the weighted effective acceleration in three orthogonal directions:

Weighted total vibration value

BT 60/4 $a_{HV} = 9.4$ m/s² on crushed rock determined acc. to ISO 5349 and EN 500

BT 65/4 $a_{HV} = 8.6$ m/s² on crushed rock determined acc. to ISO 5349 and EN 500

Caution

Observe the daily vibration load (Industrial safety acc. to 2002/44/EEC).

3 Safety regulations

Go to Discount-Equipment.com to order your parts

General

This BOMAG machine has been built in compliance with the latest technical standard and complies with the applicable regulations and technical rules. However, dangers for persons and property may arise from this machine, if:

- it is used for purposes other than the ones it is intended for,
- it is operated by untrained personnel,
- it is changed or converted in an unprofessional way,
- the safety instructions are not observed.

Each person involved in the operation, maintenance and repair of the machine must therefore read and comply with these safety regulations. If necessary, this must be confirmed by obtaining the signature of the customer.

Furthermore, the following obviously also applies:

- applicable accident prevention instructions,
- generally accepted safety and road traffic regulations,
- country specific safety regulations. It is the duty of the operator to be acquainted with these instructions and to apply these accordingly. This applies also for local regulations concerning different types of handling work. Should the recommendations in these instructions be different from the regulations valid in your country, you must comply with the safety regulations valid in your country.

Intended use

This machine must only be used for:

- Compaction of all types of soils
- Repair work in all types of soil
- Reinforcement of walkways
- Work in trenches
- Backfills and compaction of marginal strips

Unintended use

Dangers may arise from the machine when it is used for purposes other than the one it is intended for.

Any danger caused by intended use is the sole responsibility of the customer or driver/operator, the manufacturer cannot be made liable.

Examples for unintended use are:

- Working in horizontal direction
- Ramming of poles
- Vibrating of paving blocks

It is not permitted to stand on the machine while working.

Starting and operation of the machine in explosive environments and in underground mining is prohibited.

Remaining dangers, remaining risks

Despite careful work and compliance with standards and regulations it cannot be ruled out that further dangers may arise when working with and handling the machine.

Both the machine as well as all other system components comply with the currently valid safety regulations. Nevertheless, remaining risks cannot be ruled out completely, even when using the machine for the purpose it is intended for and following all information given in the operating instructions.

A remaining risk can also not be excluded beyond the actual danger zone of the machine. Persons remaining in this area must pay particular attention to the machine, so that they can react immediately in case of a possible malfunction, an incident or failure etc.

All persons remaining in the area of the machine must be informed about the dangers that arise from the operation of the machine.

Regular safety inspections

Have the machine inspected by an expert (capable person) as required for the condition the machine is working under, but at least once every year.

Who is allowed to operate the machine?

Only trained, instructed and authorized persons of at least 18 years of age are permitted to drive and operate this machine. For operation of the ma-

chine the responsibilities must be clearly specified and complied with.

Persons under the influence of alcohol, medicine or drugs are not allowed to operate, service or repair the machine.

Maintenance and repair work requires specific knowledge and must therefore only be performed by trained specialists.

Changes and conversions to the machine

Unauthorized changes to the machine are prohibited for safety reasons.

Original parts and accessories have been specially designed for this machine.

We wish to make explicitly clear that we have not tested or approved any parts or accessories not supplied by us.

The installation and/or use of such products may have an adverse effect on the active and/or passive safety.

The manufacturer explicitly excludes any liability for damage caused by the use of non-original parts or accessories.

Damage, deficiencies, misuse of safety installations

Machines which are not safe to operate must be immediately taken out of service and shall not be used, until these deficiencies have been properly rectified.

Safety installations and switches must neither be removed nor must they be made ineffective.

Notes on safety in the operating and maintenance instructions

Danger

Paragraphs marked like this highlight possible dangers for persons.

Caution

Paragraphs marked like this highlight possible dangers for machines or parts of the machine.

Note

Paragraphs marked like this contain technical information for the optimal economical use of the machine.

Environment

Paragraphs marked like this point out practices for safe and environmental disposal of fuels and lubricants as well as replacement parts.

Observe the regulations for the protection of the environment.

Loading/transporting the machine

Always shut the engine down to transport the tamper or to lay it on its side.

Make sure that persons are not endangered by the machine tipping or sliding off.

Lifting tackle must only be attached to loads by expert personnel (qualified person).

Use only safe lifting gear of sufficient load bearing capacity Minimum lifting capacity of lifting gear: see operating weight in chapter "Technical Data".

Fasten the lifting gear only at the specified lifting points.

Check all lifting and lashing points for damage before lifting or lashing down the machine. Do not use a damaged or in any other way impaired lifting and lashing eyes.

Do not lift or lower the machine jerkily.

The tension must always be effective in vertical direction.

The machine must not swing about when being lifted.

Do not step or stand under suspended loads.

Always use suitable lashing gear on the lifting points to lash down the machine.

Lash the machine down, so that it is secured against rolling, sliding and turning over.

Starting the machine

Before starting

Become acquainted with the equipment, the control elements, the working principle of the machine and the working area.

Safety regulations

Wear your personal protective outfit (hard hat, safety boots, etc.). Wear ear defenders.

Before starting the machine check whether:

- the machine shows any obvious faults
- all guards and safety elements are in place
- the controls are fully functional
- the machine is free of oily and combustible material
- all grips are free of grease, oils, fuel, dirt, snow and ice.

Examine the starter rope of the recoil starter for chafing before starting, replace if necessary. A damaged rope can break and cause injuries during starting.

Use only machines which are serviced at regular intervals.

Starting and operation of the machine is closed rooms and trenches

Exhaust gases are highly dangerous! Always ensure an adequate supply of fresh air when starting and operating in closed rooms and trenches!

Operation

- Always keep an eye on the machine when the engine is running.
- Always hold on to the machine.
- Steer the machine only by the steering handle.
- Guide the machine so that your hands do not hit against solid objects, danger of injury.
- Keep your feet clear of the tamper foot plate.
- Wear your personal noise protection (ear defenders).
- Watch out for unusual noises and development of smoke. Perform trouble shooting and have the fault corrected.
- Do not hold the throttle lever in the area below 3600 min^{-1} , since this would destroy the centrifugal clutch.

Parking the machine

Stand the machine on ground as level as possible.

Before leaving the machine:

- Secure the machine against tipping over.

Refuelling

Do not inhale any fuel fumes.

Do not swallow fuel.

Avoid contact with skin and eyes.

Refuel only with the engine shut down.

Do not refuel in closed rooms.

No open fire, do not smoke.

Do not spill any fuel. Catch running out fuel, do not let it seep into the ground.

Keep dirt and water away from the fuel.

A leaking fuel tank can cause an explosion. Ensure tight fit of the fuel tank cover, if necessary replace immediately.

Fuel stabilizer

Fuel stabilizer is inflammable. No open fire, do not smoke. Do not spill any fuel stabilizer.

Do not inhale any fuel stabilizer fumes.

Do not swallow fuel stabilizer.

Avoid contact with skin and eyes.

Maintenance work

Comply with the maintenance work described in the operating and maintenance instructions, including the information concerning the replacement of parts.

Maintenance work must only be performed by qualified and authorized persons.

Keep unauthorized persons away from the machine.

Do not touch hot engine parts.

Generally perform maintenance work only with the engine shut down and the spark plug socket disconnected.

Park the machine on level and solid ground and secure it against tipping over.

Working on the fuel system

Do not inhale any fuel fumes.

Do not swallow fuel.

Avoid contact with skin and eyes.

Avoid open fire, do not smoke, do not spill any fuel.

Catch running out fuel, do not let it seep into the ground and dispose off environmentally.

Working on the engine

When working on the air filter no dirt should fall into the air duct.

Do not work on the hot exhaust - danger of burning!

When working on the engine exhaust duct no combustion residues should fall into the cylinder.

Do not touch the piston with the cleaning tools.

Working on the tamper foot

Wipe off spilled oil, catch running out oil and dispose of environmentally.

Store oil contaminated materials in a separate, specially marked container and dispose of environmentally.

Cleaning work

Do not perform cleaning work while the motor is running.

Do not use gasoline or other easily inflammable substances for cleaning.

When using a steam cleaner for cleaning do not subject electrical parts and insulation material to the direct jet or cover these items beforehand.

Do not guide the water jet directly into air filter, exhaust pipe and air intake opening.

After maintenance work

After all maintenance work is completed reinstall all guards and safety installations.

Repair

Repairs must only be carried out by qualified and authorized personnel. Always follow our repair instructions.

Exhaust gases are highly dangerous! Always ensure an adequate supply of fresh air when starting in closed rooms!

Attach a warning tag to the steering bow if the machine is defective.

- Do not mix the nozzle in the carburettor up by mistake.
- Adjust the idling speed regulator screw exactly.
- Do not damage the blower wheel when working on the magnetic ignition.
- Always replace self locking nuts.

- Do not open the foot cover on the tamper foot, spring tension. Danger of accident!
- Observe the prescribed tightening torques.

Information and safety stickers/decals on the machine

Keep safety stickers in good and legible condition (see parts manual) and comply with their meaning.

Replace damaged and illegible stickers/decals.

Safety regulations

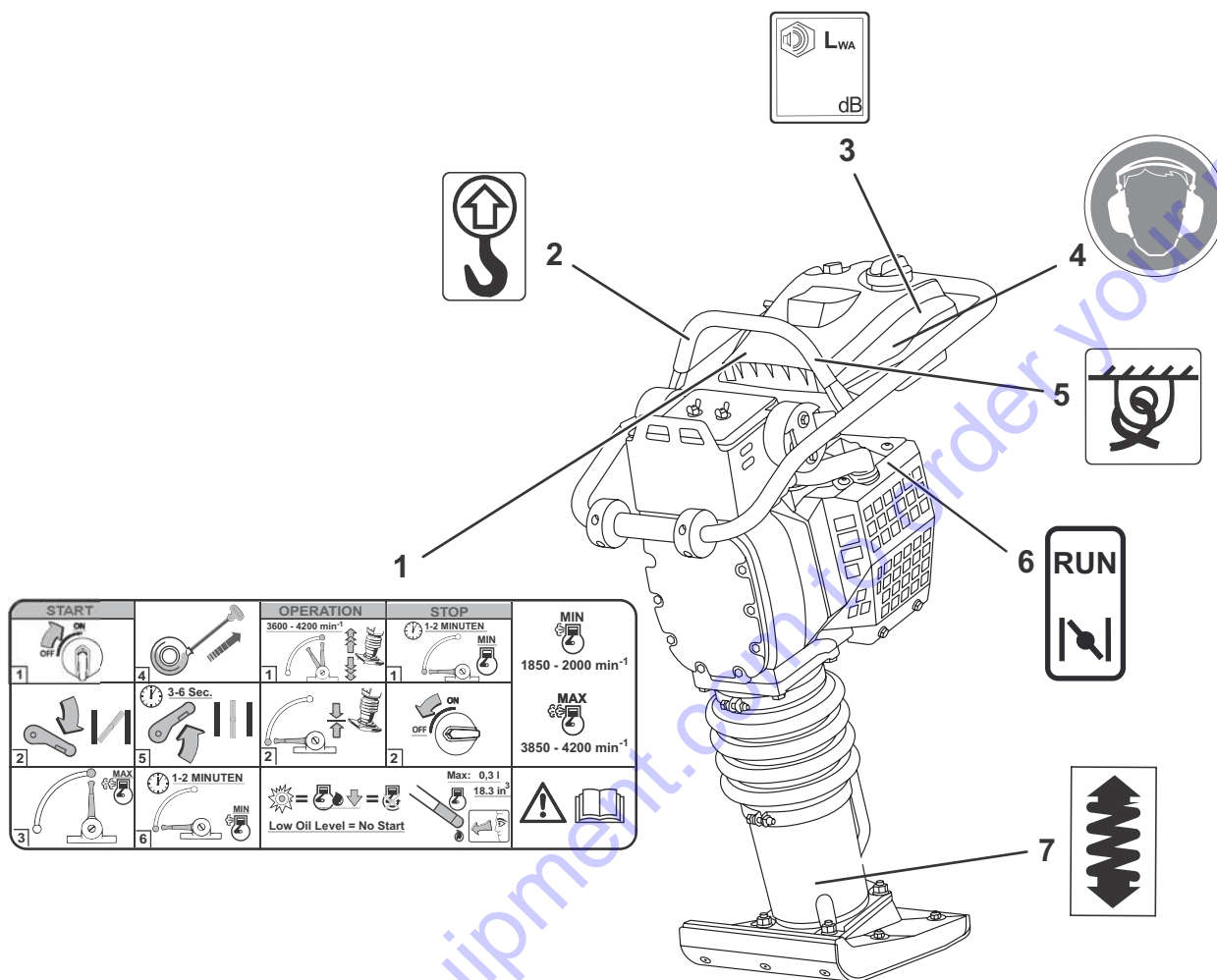

Fig. 6

540235

Stickers and decals

- | | |
|---|--|
| 1 Brief operating instructions | 4 Instruction sticker - Wear ear defenders |
| 2 Information sticker - Lifting point | 5 Information sticker - Lashing point |
| 3 Information sticker - Guaranteed sound capacity level | 6 Information sticker - Choke lever |
| | 7 Warning sticker - Spring |

4 Indicators and Controls

4.1 General notes

If you are not yet familiar with the control and display elements on this machine you should read this section thoroughly before starting any operation on the machine. Here all functions are described in detail.

The section "Operation" contains only brief descriptions of the individual control steps.

4.2 Description of indicators and control elements

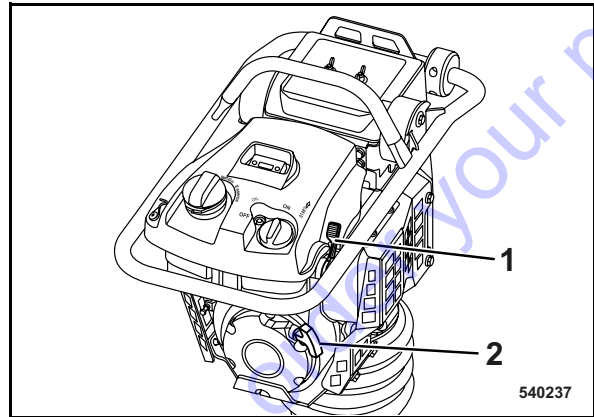

Fig. 7

No. 1 = Throttle lever

No. 2 = Recoil starter

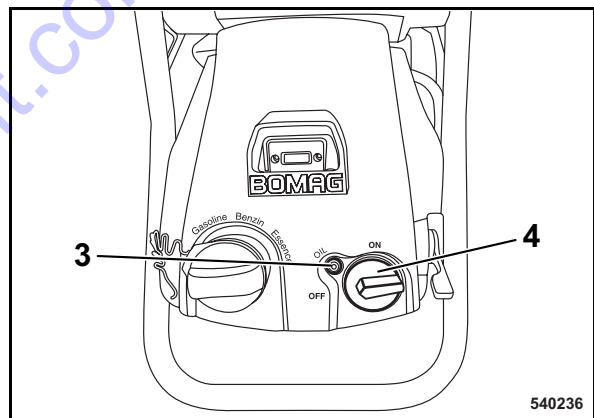

Fig. 8

No. 3 = Engine oil level warning lamp

No. 4 = Engine stop switch

Position

"OFF" = Fuel valve closed, engine off

Position

"ON" = Fuel valve open, engine can be started

⚠ Caution

If the oil level warning lamp (3) (Fig. 8) lights up when starting the engine, the oil level must be corrected, as otherwise the engine cannot be started.

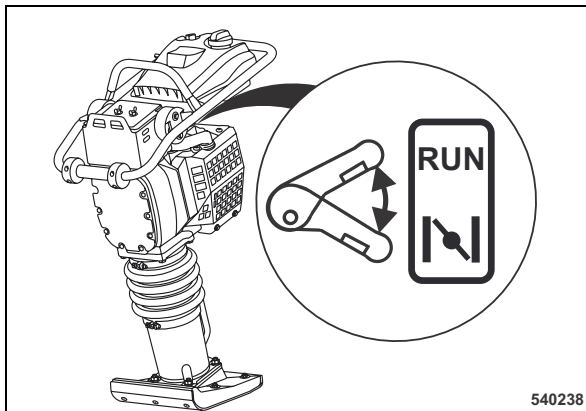

Fig. 9

No. 5 = Choke lever

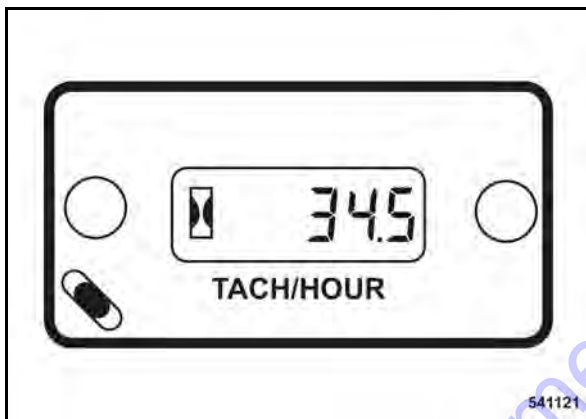

Fig. 10

No. 6 = Operating hour meter/engine speed meter

Engine off = Indication of operating hours

Engine on = RPM-meter

Service indicator (SVC):

- This service indicator appears when maintenance is due (after 25 operating hours, then every 100 operating hours).
- Before maintenance is due, the indicator flashes over a period of 2 operating hours "SVC DUE in ..." together with the duration (in hours) until service is required.
- If maintenance is already required, the indicator flashes for another 2 hours "SVC DUE NOW".

i Note

The service indicator cannot be reset.

5 Operation

5.1 General

If you are not yet acquainted with the controls and indicating elements on this machine you should thoroughly read chapter "Indicators and control elements" before starting work.

All indicators and control elements are described in detail in this chapter.

5.2 Tests before taking into operation

i Note

During the running in time the idle speed may increase because of the enhanced moveability of the engine. Idle speeds between 1850 and 2000 min⁻¹.

The running in time of the vibratory tamper is 10 operating hours.

The following inspections must be carried out before each working day or before a longer working period.

▲ Danger

Danger of accident!

Please observe strictly the safety regulations in the corresponding section of this instruction manual!

- Park the machine on ground as level as possible.

Check:

- condition of engine and machine
- fuel tank and fuel lines for leaks
- screw joints for tight fit

i Note

For a description of the following tasks refer to the chapter "Daily maintenance".

- Engine oil level, top up if necessary
- Fuel level, top up if necessary.

5.3 Adjusting the steering bow

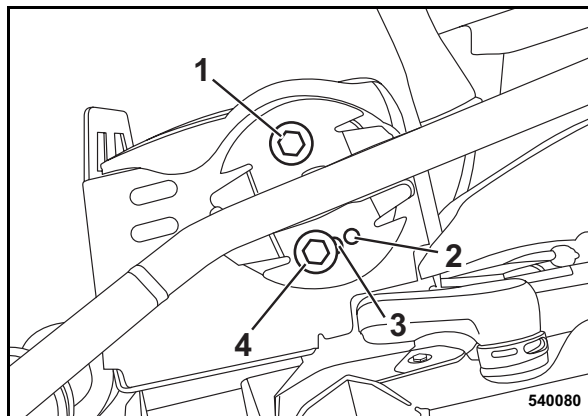

Fig. 11

i Note

The steering bow has three positions.

The steering bow can be adjusted to the height of the operator by using the bore holes (2), (3) and (4) (Fig. 11):

- (2) lowest position
- (3) middle position
- (4) highest position

- Loosen the screws (1) on both sides
- Loosen the screws (4) on both sides and pull them out.
- Set the steering bow to the desired height.
- Tighten screws (1) and (4) on both sides.

5.4 Starting the engine

⚠ Danger

Exhaust gases are highly dangerous!

Always ensure an adequate supply of fresh air when starting and operating in closed rooms and trenches!

⚠ Danger

Danger of accident!

Examine the starter rope of the recoil starter for chafing before starting, replace if necessary. A damaged rope can break and cause injuries during starting.

Always hold on to the machine.

Keep your feet away from the tamper plate, because the vibration starts immediately.

Always keep an eye on a running machine.

⚠ Danger

Loss of hearing!

Wear your personal noise protection means (ear defenders) before starting operation.

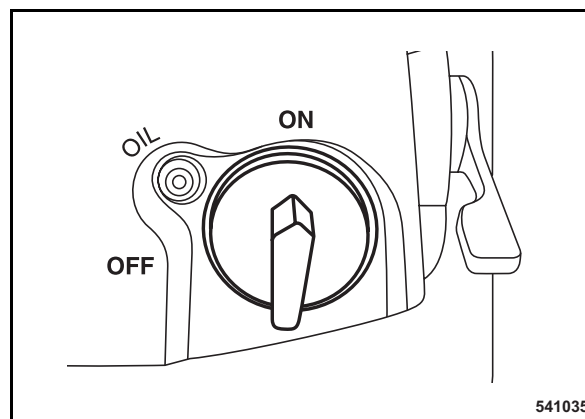

Fig. 12

- Set the engine stop switch (Fig. 12) to position "ON".

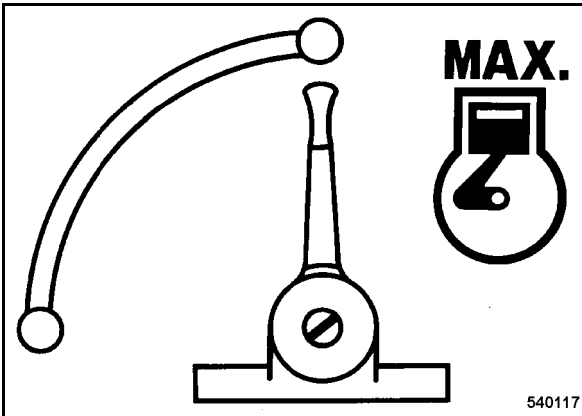

Fig. 13

- Set the throttle lever (Fig. 13) to position "MAX".

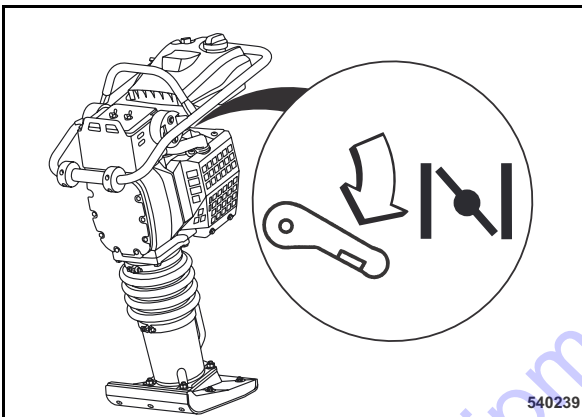

Fig. 14

- Close the choke (Fig. 14).

i Note

Always close the choke to start a cold and warm engine.

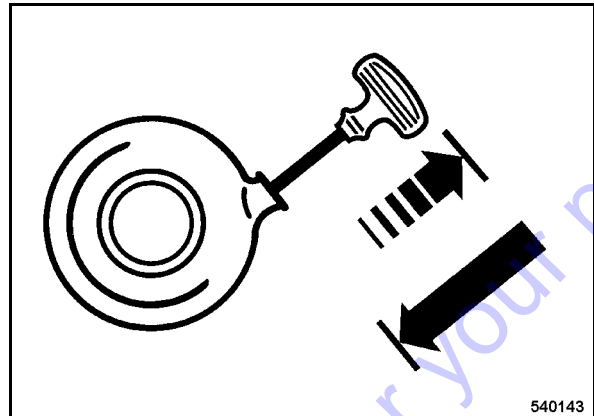

Fig. 15

- Pull the rope by the starter handle (Fig. 15) until resistance can be felt.
- Let the starter handle run back to initial position.

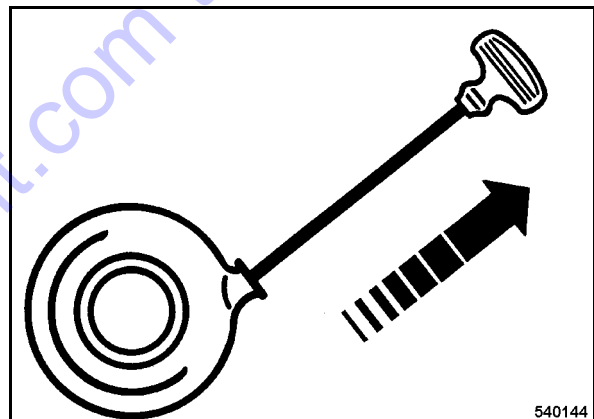

Fig. 16

- Pull the starter handle quickly and with power (Fig. 16).

⚠ Caution

Do not let the starter handle hit back.

- Guide the starter handle back to initial position by hand.
- If the engine does not start during the first attempt, repeat the starting process.

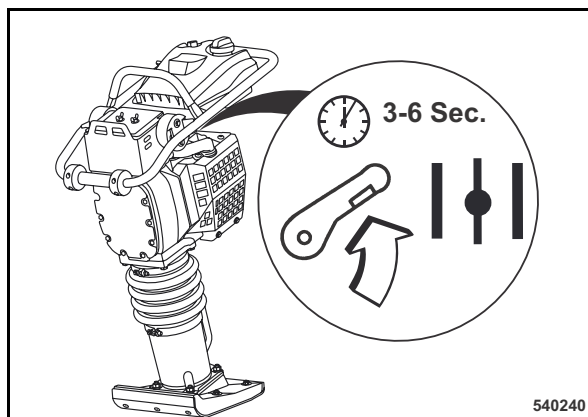

Fig. 17

- Open the choke (Fig. 17) 3 to 6 seconds after the engine has started running.

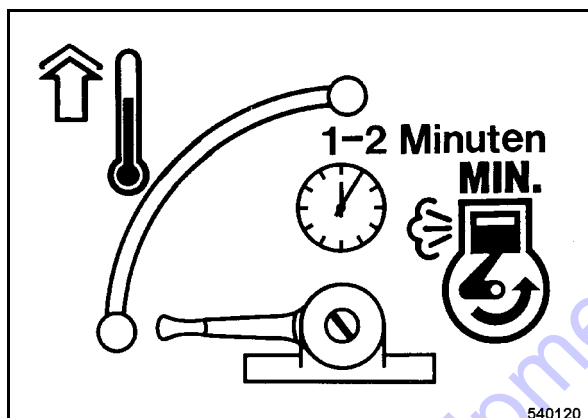

Fig. 18

- Set the throttle lever (Fig. 18) to position "MIN" and let the engine run warm for 1 to 2 minutes.

i Note

Once the engine has warmed up you can start to work with the tamper.

Starting under cold weather conditions

- If the engine stops again after approx. 3 to 5 seconds, close the choke again and repeat the starting process.

Engine oil level too low

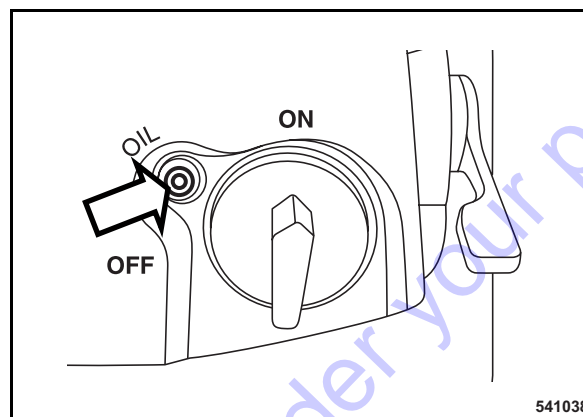

Fig. 19

The engine does not start if the oil level is too low. This is indicated by the engine oil level warning lamp (Fig. 19) when operating the recoil starter.

- Check the engine oil level, fill up if necessary.
- Repeat the starting procedure.

Engine "drowned"

i Note

When the choke is closed and the starter rope is pulled several times, the engine draws in too much fuel and will probably not start.

Remedy

- Set the engine stop switch to position "OFF" (fuel valve closed).
- Open the choke.
- Set the throttle lever to full speed position.
- Operate the starter rope 10-20 times.
- Set the engine stop switch to position "ON"
- Operate the starter rope once again.

i Note

If the engine does not start after 3 to 5 attempts

- Close the choke.
- Operate the starter rope once again.

i Note

If the engine does not start after 3 to 5 attempts

Operation

- pull off the spark plug socket.
- unscrew the spark plug.
- operate the starter several times.
- Dry the spark plug with a clean cloth or blow it dry with compressed air. If necessary clean with a wire brush.
- Screw the spark plug back in and plug the spark plug socket back on.
- Repeat the starting procedure.

5.5 Work/operation

⚠ Danger

Danger of accident! Danger of injury!

Always keep an eye on the machine when the engine is running.

Always hold on to the machine.

Steer the machine only by the steering handle.

Guide the machine so that your hands do not hit against solid objects.

Keep your feet clear of the tamper foot plate.

Wear your personal noise protection (ear defenders).

Watch out for unusual noises and development of smoke. Perform trouble shooting and have the fault corrected.

⚠ Caution

Do not hold the throttle lever in the area below 3600 min^{-1} , since this would destroy the centrifugal clutch.

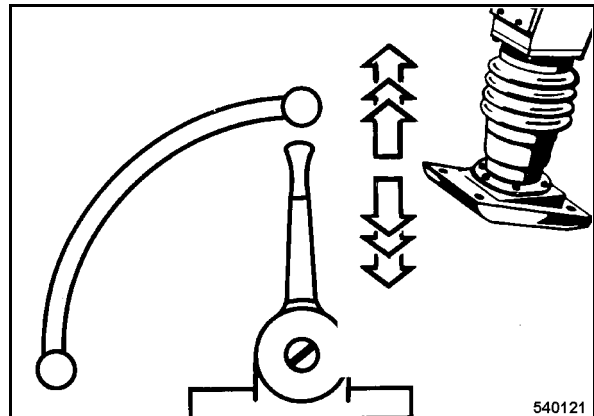

Fig. 20

- Set the throttle lever (Fig. 20) to position "MAX".

The machine works with highest frequency.

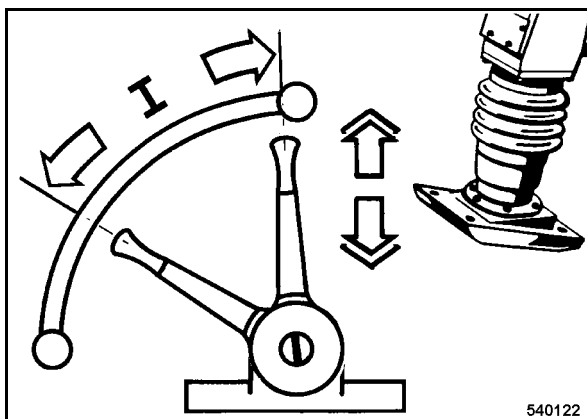

Fig. 21

- To achieve uniform running you should actuate the throttle lever within range "I" (3600 bis 4200 min⁻¹) (Fig. 21), depending on condition and density of soil.

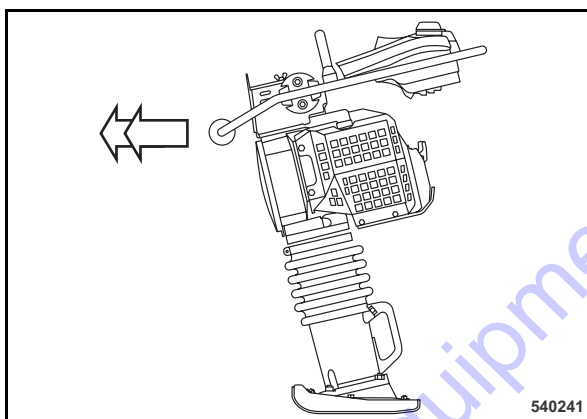

Fig. 22

- The forward moving speed can be influenced by applying weight on the steering bow.

No load = slowly forward (Fig. 22)

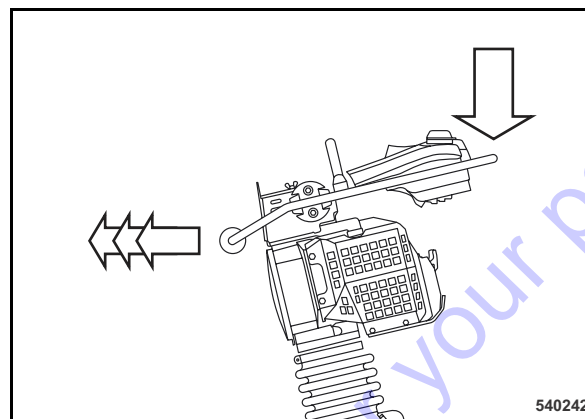

Fig. 23

Strong pressure = fast forward (Fig. 23)

i Note

The layer thickness of the material to be compacted should not be higher that is possible for the vibratory tamper to cope with.

Should the tamper get out of its vibrating rhythm on excessively compacted soil, harmonic running of the tamper can be achieved again by slightly altering the steep and/or inclination of the tamper.

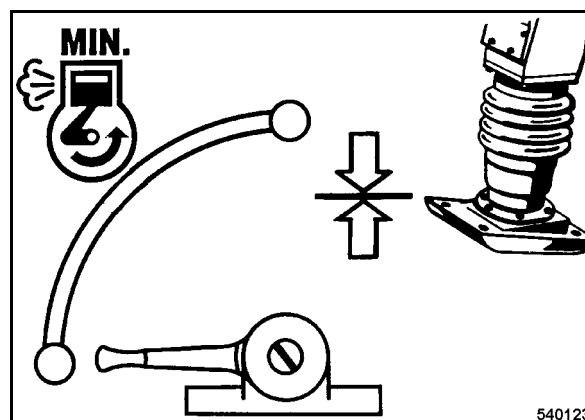

Fig. 24

- Always shift the throttle lever to position "MIN" for short work breaks (Fig. 24).

i Note

This prevents premature wear of the centrifugal clutch and enhances the fuel economy.

5.6 Shutting down the engine

⚠ Caution

Do not shut the engine down all of the sudden from full speed, but let it idle for a while for temperature equalization.

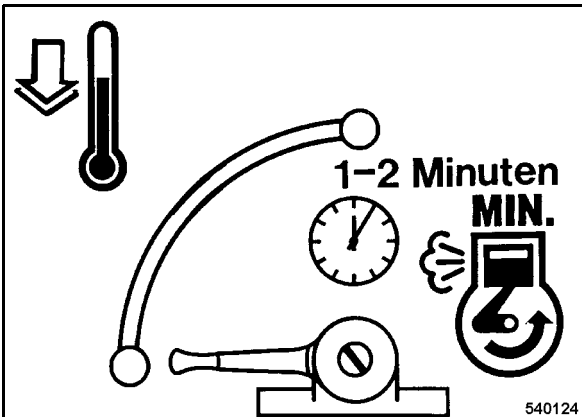

Fig. 25

- Set the throttle lever (Fig. 25) to position "MIN" (idle speed).
- Run the engine for a short while in idle speed.

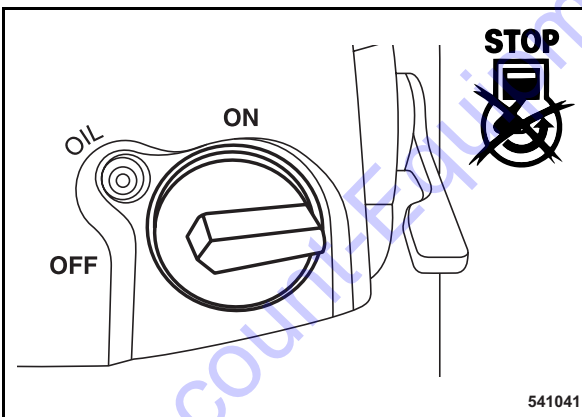

Fig. 26

- Set the engine stop switch (Fig. 26) to position "OFF".

⚠ Danger

Danger of burning! Danger of accident!

Immediately after shutting down the engine is still hot, do not touch the exhaust.

Park the machine so that it cannot turn over.

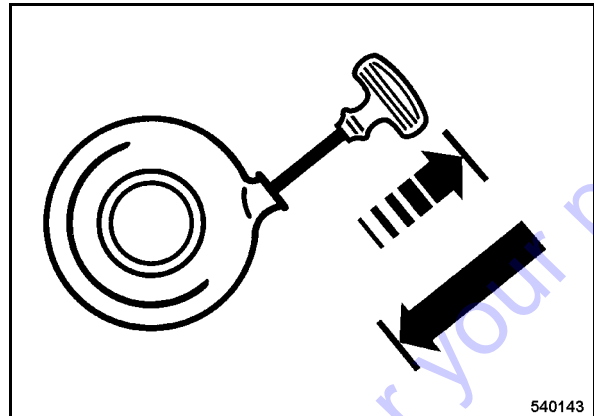

Fig. 27

- Pull the rope by the starter handle (Fig. 27) until resistance can be felt.
- Let the starter handle run back to initial position.

i Note

This procedure protects against moisture deposits inside the engine.

5.7 Changing the tamper foot plate

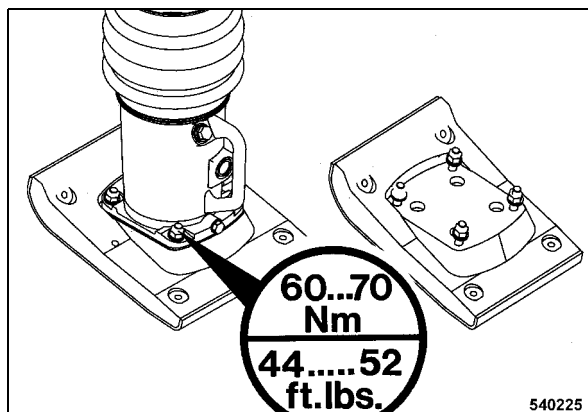

Fig. 28

- After changing the tamper foot plate (Fig. 28) tighten the 4 fastening screws with a tightening torque of 60 to 70 Nm (44 to 52 ft.lbs).

i Note

When changing the tamper foot to a different width use only genuine BOMAG parts.

After changing the tamper foot check the engine speed, adjust it if necessary.

5.8 Loading/transport

▲ Danger

Danger of accident! Life hazard!

Always shut the engine down to transport the tamper or to lay it on its side.

Make sure that persons are not endangered by the machine tipping or sliding off.

Lifting tackle must only be attached to loads by expert personnel (qualified person).

Use only safe lifting gear of sufficient load bearing capacity Minimum lifting capacity of lifting gear: see operating weight in chapter "Technical Data".

Fasten the lifting gear only at the specified lifting points.

Check all lifting and lashing points for damage before lifting or lashing down the machine. Do not use a damaged or in any other way impaired lifting and lashing eyes.

Do not lift or lower the machine jerkily.

The tension must always be effective in vertical direction.

The machine must not swing about when being lifted.

Do not step or stand under suspended loads.

Always use suitable lashing gear on the lifting points to lash down the machine.

Lash the machine down, so that it is secured against rolling, sliding and turning over.

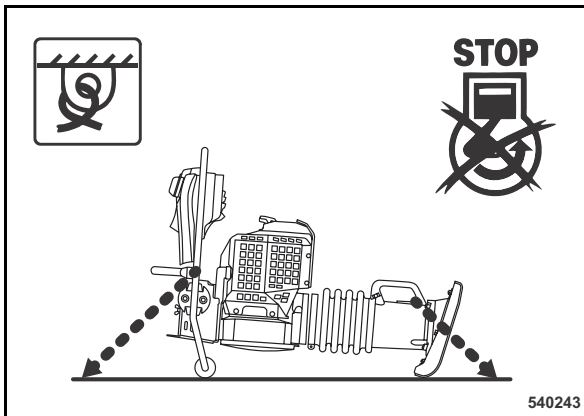

Fig. 29

- Always shut the engine down to transport the tamper or to lay it on its side.
- Lay down the tamper (Fig. 29) to transport it on the rollers.
- Lash the tamper down to the transport vehicle, so that it is secured against rolling, sliding and turning over.

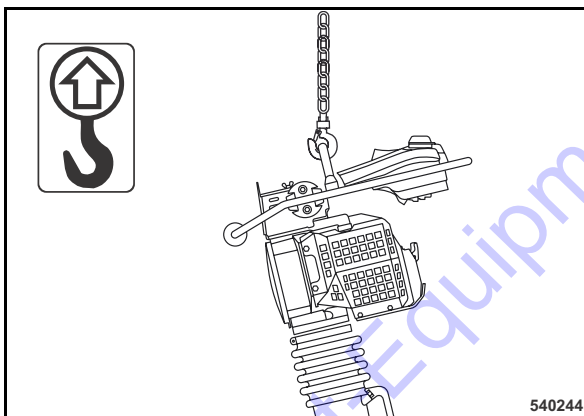

Fig. 30

- For loading the machine attach the lifting gear only to the lifting eye provided for this purpose (Fig. 30).

6 Maintenance

6.1 General notes on maintenance

When performing maintenance work ensure strict compliance with the respective safety instructions and particularly the safety regulations mentioned in the corresponding section of these operating and maintenance instructions.

Thorough maintenance of the machine guarantees far longer safe functioning of the machine and prolongs the lifetime of important components. The effort needed for this work is only little compared with the problems that may arise when not observing this rule.

- Always clean machine and engine thoroughly before starting maintenance work.
- For maintenance work stand the tamper on level ground and secure it against tipping over.
- Do not touch hot engine parts.
- Generally perform maintenance work only with the engine shut down and the spark plug socket disconnected.

Environment

During maintenance work catch all oils and fuels and do not let them seep into the ground or into the sewage system. Dispose of oils and fuels environmentally.

Keep used filters in a separate waste container and dispose of environmentally.

Notes on the fuel system

The lifetime of the engine mainly depends on the purity of the fuel.

- Keep fuel clean of any contamination and water.
- When choosing the storage place for fuel make sure that spilled fuel will not harm the environment.

Fresh fuel should not be stored for longer than 3 months, if no fuel stabilizer has been added.

When storing for longer than 3 months:

- Directly after buying fresh fuel add the correct amount of fuel stabilizer to the fuel (follow the instructions of the manufacturer).

Notes on the performance of the engine

On engines both combustion air and fuel injection quantities are thoroughly adapted to each other and determine power, temperature level and exhaust gas quality of the engine.

If your engine has to work permanently in "thin air" (at higher altitudes) and under full load, you should consult our customer service or the customer service of the engine manufacturer.

Frequent causes of faults

- Operating errors
- Incorrect, inadequate maintenance

If you cannot locate the cause of a fault or rectify it yourself by following the trouble shooting chart, you should contact our customer service department.

6.2 Fuels and lubricants

Engine oil

Quality

The oil is an essential factor for the performance and lifetime of the engine.

Use engine oil for four-stroke engines which meets or even exceeds the requirements for API-service class SJ or higher (or equivalent).

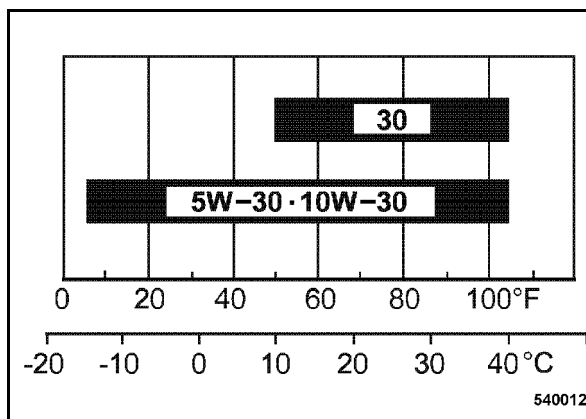

Fig. 31

Viscosity

Since lubrication oil changes its viscosity with the temperature, the ambient temperature at the operating location of the engine is of utmost importance when choosing the viscosity class (SAE-class) (see diagram (Fig. 31)).

SAE10W-30 is recommended for general use under any temperature. When using single purpose oil you must choose the correct viscosity for the area of use. You may alternatively use 15W-40 (except under low temperatures).

Temperature related lubrication oil changes can be avoided by using multi-purpose oils. The following oil change intervals apply also when using multi-purpose oils.

Change intervals

The longest permissible time the lubrication oil should remain in an engine is 1/2 year or 100 operating hours.

Fuel

Quality

The engine has been approved for operation with unleaded gasoline with a octane number of 91 or higher (or Pump Octane Number" 86 or higher).

Use only commercially available brand fuel.

You can use unleaded standard grade petrol with maximum 10 percent by volume of ethanol (E10) or maximum 5 percent by volume of methanol.

Methanol must also contain co-solvents and corrosion inhibitors.

Using fuels with higher ethanol or methanol contents exceeding the values specified above may cause starting difficulties and/or performance problems. Damage may also occur to metal, rubber or plastic parts in the fuel system.

Engine damage and performance problems caused by the use of fuels with higher ethanol or methanol percentages than the ones specified above are not covered under warranty.

Fuel stabilizer

If the machine is only occasionally used (i.e. if it is out of use for longer than 4 weeks), mix in the correct amount of fuel stabilizer (BOMSAG 009 940 20) directly after you have purchased fresh fuel (follow the instructions of the manufacturer).

The fuel stabilizer has a limited shelf life. The effect diminishes over the course of time (store for max. 2 years after opening the bottle).

Fuel cannot be regenerated by using fuel stabilizer.

Tamper foot oil

For the tamper foot use a fully synthetic gear oil SAE 75W-90, API GL5.

6.3 Table of fuels and lubricants

Assembly	Fuel or lubricant		Quantity approx. Attention! Observe the level marks
	Summer	Winter	
Motor -Engine oil	Engine oil API SJ or higher SAE 10W-30 (-20 °C to +30 °C) (-4 °F to +86 °F) SAE 15W-40 (-15 °C to +40 °C) (+5 °F to +104 °F) SAE 30 (+10 °C to +30 °C) (+50 °F to +86 °F)		0.3 l (0.08 USgal) up to dipstick mark
- Fuel	Gasoline (unleaded)		3.0 l (0.80 USgal)
Padfoot	SAE 75W-90, API GL-5 (BOMAG 009 925 05; 20 l)		BT60/4: 0.75 l (0.20 USgal) BT65/4: 1.0 l (0.26 USgal)

6.4 Running-in instructions

The following maintenance work must be performed when running in new machines or overhauled engines:

⚠ Caution

During the running-in period, up to approx. 200 operating hours, check the engine oil level twice every day.

Depending on the load the engine is subjected to, the oil consumption will drop to the normal level after approx. 100 to 200 operating hours.

After approx. 25 operating hours

- Change the engine oil.
- Check the idel speed and the max. speed of the engine, adjust if necessary.
- Check engine and machine for leaks.
- Retighten the fastening screws on air filter exhaust, fuel tank and other attachments.
- Retighten the bolted connections on the machine.

6.5 Maintenance table

No.	Maintenance work	Comment	daily	monthly	annually	as required
6.6	Clean the machine	in case of extreme dust clean every day	X			
6.7	Check the engine oil level	Dipstick mark	X			
6.8	Check the fuel level		X			
6.9	Change the engine oil	at least every 100 operating hours or 1x per year		X		
6.10	Clean, check the spark plug, replace if necessary			X		
6.11	Check the tamper foot			X		
6.12	Check, adjust the valve clearance	Intake valve: 0.15 mm (0.006 in) Exhaust: 0.20 mm (0.008 in)			X	
6.13	Change the fuel filter				X	
6.14	Cleaning the fuel screen				X	
6.15	Check, adjust the engine speed				X	
6.16	Replacing the starter rope				X	
6.17	Oil change in tamper foot				X	
6.18	Check, clean the air filter, replace if necessary	in case of a drop in the max. engine speed replace at least 1 x year				X

6.6 Clean the machine

⚠ Caution

Perform cleaning work only after the engine has cooled down and with the engine stopped.

Dirty operating conditions, particularly lubrication oil and fuel deposits on the cooling fins of the engine and the cooling air intake opening have an adverse effect on the cooling of the engine.

You should therefore immediately seal any oil or fuel leaks near fuel tank, cylinder or cooling air intake.

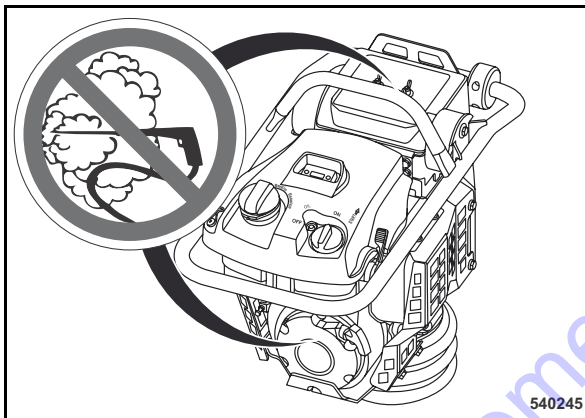

Fig. 32

⚠ Caution

Do not guide the water jet into the air intake and the recoil starter (Fig. 32).

- After wet cleaning run the engine warm to evaporate all water residues and to avoid corrosion.

6.7 Check the engine oil level

⚠ Caution

Check the engine oil level with highest care, to avoid over or underfilling of the engine. Underfilling can damage the engine. Overfilling causes excessive development of smoke and can also lead to engine damage

The engine cannot be started if the engine oil level is too low.

For quality of oil refer to the "table of fuels and lubricants".

- Stand the tamper on flat and level ground.
- Shut down the engine.

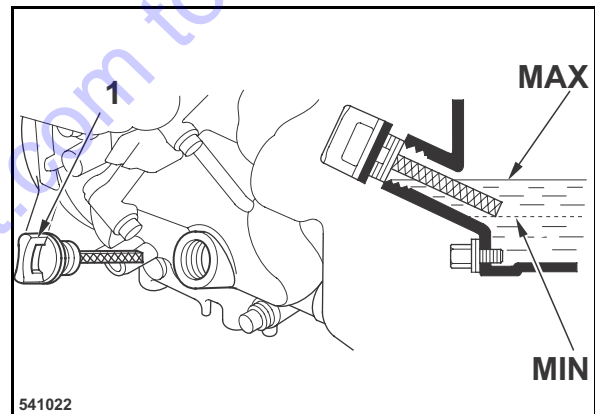

Fig. 33

- Clean the area around the oil dipstick (1) (Fig. 33).
- Unscrew the dipstick and wipe it clean with a lint-free, clean cloth.
- Insert the dipstick into the oil filler socket, do not screw it in, but pull it out again to check the oil level.
- If the oil level is near or below the bottom limit mark on the dipstick, fill in recommended oil up to the top dipstick mark (bottom edge of oil filler neck). Do not overfill.

6.8 Check the fuel level

⚠ Danger

Fire hazard!

When working on the fuel system do not use open fire, do not smoke, do not spill any fuel.

Do not refuel in closed rooms.

Shut down the engine.

A leaking fuel tank can cause an explosion. Ensure tight fit of the fuel tank cover, if necessary replace immediately.

⚠ Danger

Health hazard!

Do not inhale any fuel fumes.

⚠ Caution

Contaminated fuel can cause malfunction or even damage of the engine.

Fill in fuel through the screen filter.

For quality and quantity of fuel refer to the "table of fuels and lubricants".

♻ Environment

Catch running out fuel, do not let it seep into the ground.

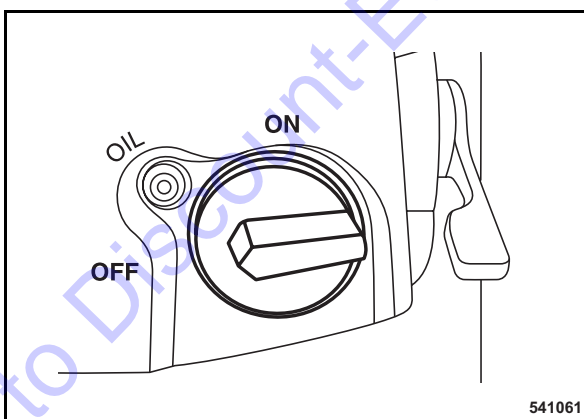

Fig. 34

- Set the engine stop switch (Fig. 34) to position "OFF" (fuel valve closed).

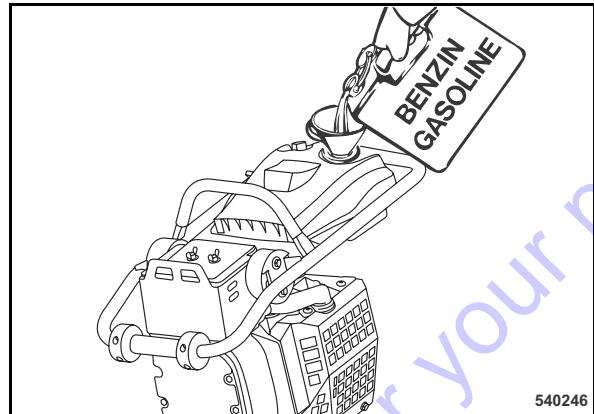

Fig. 35

- Clean the area around the filler cover, unscrew the filler cover (Fig. 35).
- Fill in fuel through a funnel with screen.
- Close the tank again.

6.9 Change the engine oil

⚠ Danger

Danger of scalding when draining off hot engine oil.

⚠ Caution

Park the machine on level ground.

Drain the engine oil only when the engine is warm.

Check the engine oil level with highest care, to avoid over or underfilling of the engine. Underfilling or overfilling can damage the engine.

The engine cannot be started if the engine oil level is too low.

For quality and quantity of oil refer to the "table of fuels and lubricants".

♻ Environment

Catch running out old oil, do not let it seep into the ground and dispose off environmentally.

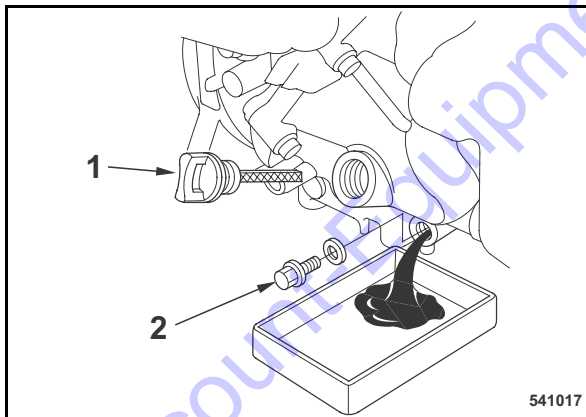

Fig. 36

- Clean the area around oil dipstick (1) (Fig. 36) and drain plug (2).
- Unscrew the oil dipstick .
- Unscrew the oil drain plug , let the old oil run out and catch it.
- Clean the drain plug and screw it back in with a new seal ring.
- Fill in fresh engine oil through the oil filler opening .

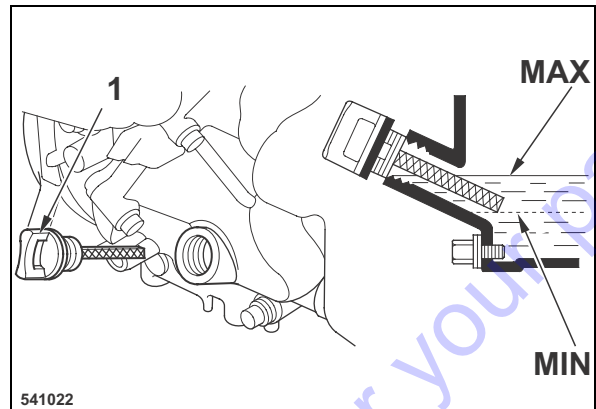

Fig. 37

- The oil level must reach the bottom edge of the filler bore (Fig. 37), top up if necessary.
- Push the oil dipstick (1) back in.
- Perform a test run, inspect the drain plug for leaks and check the oil level.

6.10 Cleaning, checking the spark plug, replacing if necessary

⚠ Danger

Danger of burning!

Let the engine cool down for approx. 15 minutes before unscrewing the spark plug.

⚠ Caution

In case of excessive combustion residues or burned off electrodes replace the spark plug.

Do not use spark plugs with incorrect heat value. An incorrect spark plug can cause damage to the engine.

Recommended spark plugs:

NGK: CR5HSB

Denso: U16FSR-UB

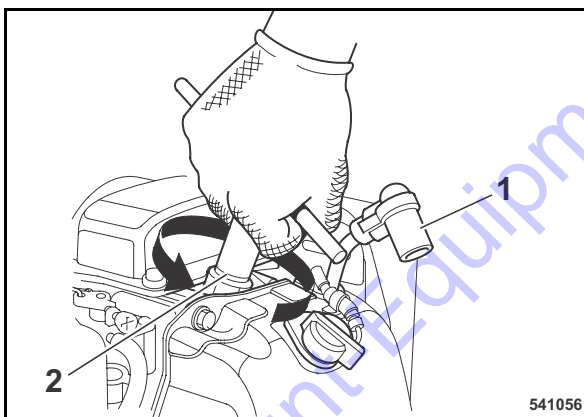

Fig. 38

- Pull off the spark plug socket (1) (Fig. 38).
- Unscrew the spark plug using a 5/8 inch spark plug spanner.

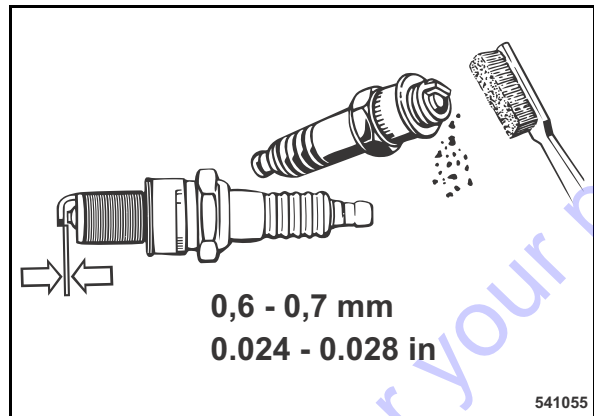

Fig. 39

- Check the spark plug (Fig. 39) visually and clean it if necessary.
- Check the electrode gap with a feeler gauge, if necessary adjust the gap to 0.6 - 0.7 mm (0.024 - 0,028 in).
- Turn the spark plug carefully in by hand.
- Once the sealing surface of the new spark plug is in contact tighten for another 1/2 turn with the spark plug spanner.
- Once the sealing surface of the used spark plug is in contact tighten for another 1/8 to 1/4 turn with the spark plug spanner.
- Press the spark plug socket back on.

6.11 Check the tamper foot

Check the oil level

⚠ Caution

Stand the tamper on level ground for a short while, so that all oil can run into the housing.

For quality of oil refer to the "table of fuels and lubricants".

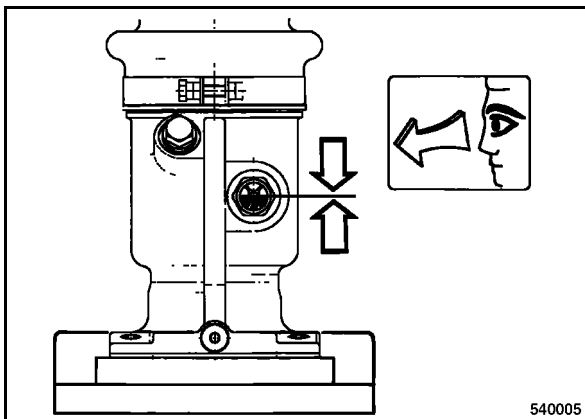

Fig. 40

- Clean the sight glass (Fig. 40).
- Check the oil level.
- The oil must be visible in the inspection glass, top up if necessary.

Check the concertina wall

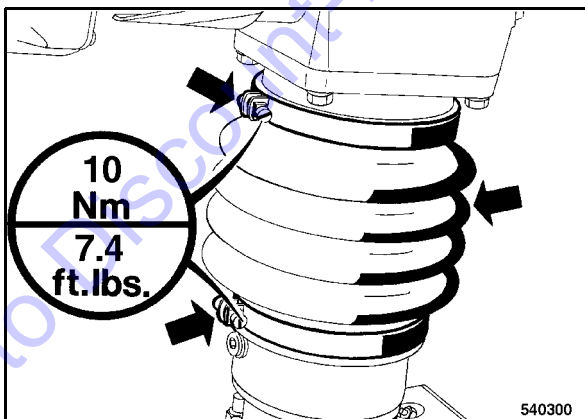

Fig. 41

- Check concertina wall for condition, damage and tight fit.

- Check hose clamps for tight fit (Fig. 41).

Retighten the screws in the tamper foot plate

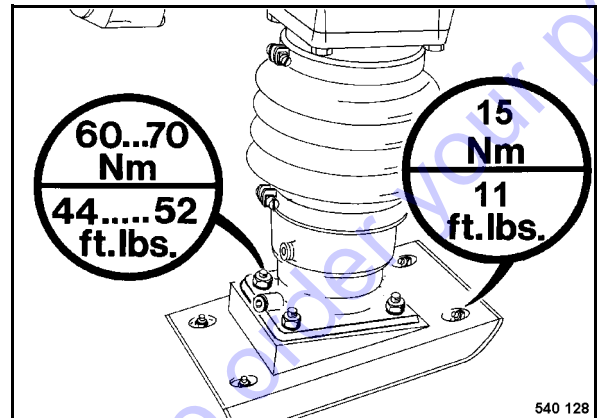

Fig. 42

- Retighten the screws (Fig. 42).

6.12 Check, adjust the valve clearance

⚠ Caution

We recommend to have this work carried out by trained personnel or our after sales service.

Check and adjust only when the engine is cold (approx. 20 °C (68 °F)).

Valve clearance:

Intake valve (IN) = 0.15 mm (0.006 in)

Exhaust valve (EX) = 0.20 mm (0.008 in)

- Shut down the engine.

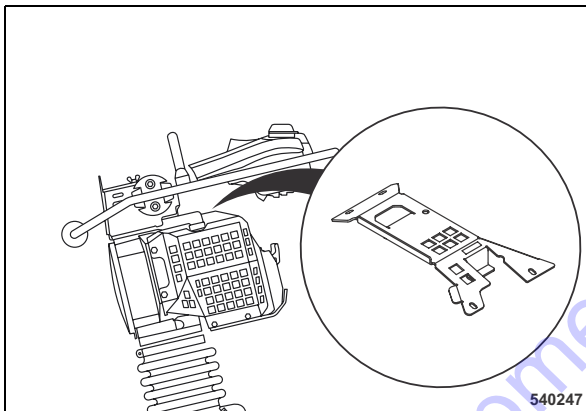

Fig. 43

- Remove the top engine cover (Fig. 43).

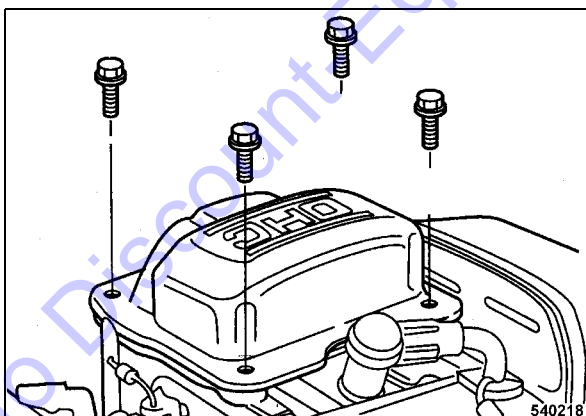

Fig. 44

- Unscrew the fastening screws for the cylinder head cover (Fig. 44).

⚠ Caution

Do not apply force to remove the cylinder head cover.

Replace the cylinder head cover if it is dented.

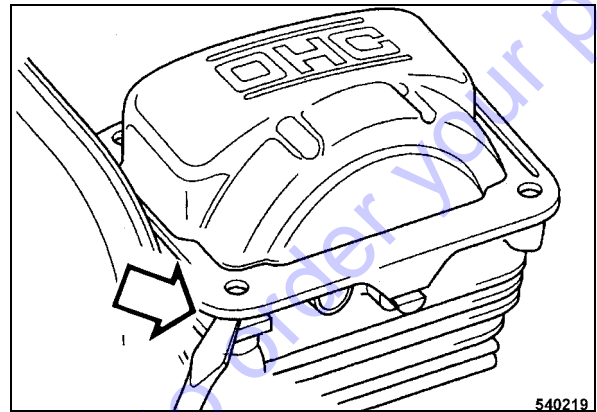

Fig. 45

- Insert the screw driver into the recess (Fig. 45) and take the cylinder head cover carefully off.

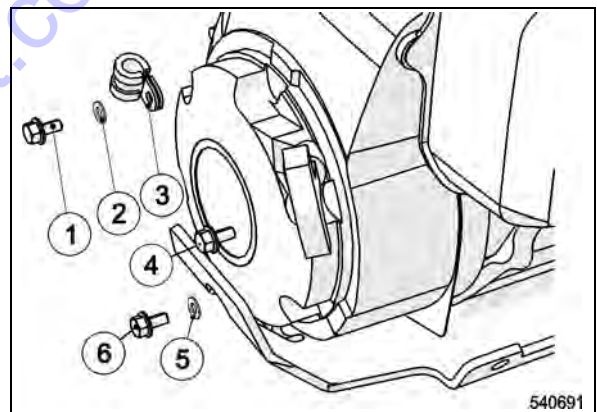

Fig. 46

⚠ Caution

Do not mix up the recoil starter fastening screws by mistake!

- Unscrew the fastening screws (1), (4) and (6) (Fig. 46) and take off the recoil starter.

Maintenance every year

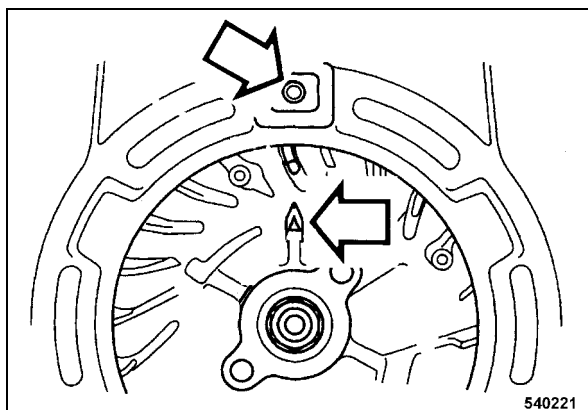

Fig. 47

- Align the alignment mark on the flywheel rib (Fig. 47) with the top bore in the fan cover .

i Note

The piston is in top dead centre of the compression stroke.

However, if the exhaust valve is open when aligning the marks, the flywheel must be turned further by 360°.

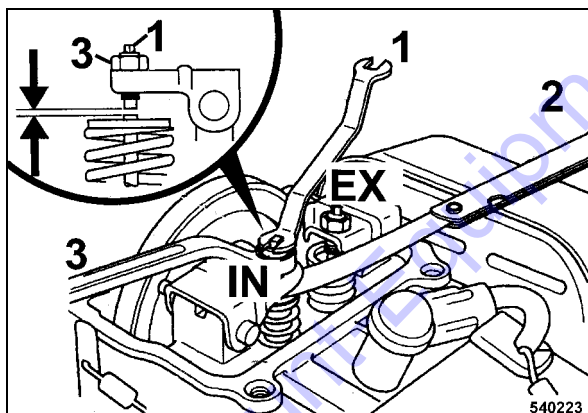

Fig. 48

- Measure the valve clearance with a feeler gauge (2) (Fig. 48).
- To adjust the valve hold the valve adjustment screw (1) and loosen locking nut (3).
- Turn the valve adjustment screw in or out, as required.
- Retighten the locking nut with a tightening torque of 7.5 Nm (5.5 ft.lbs).

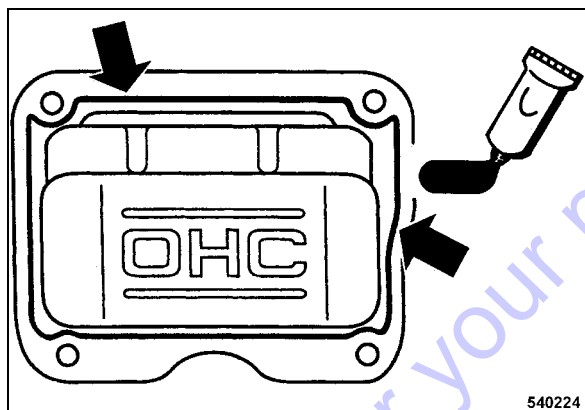

Fig. 49

- Clean the sealing faces on cylinder head cover and cylinder block.
- Apply a bead of liquid gasket (Three Bond 1207B or similar) with a diameter of approx. 1.5 to 2 mm (0.06 to 0.08 in) to the inside of the cylinder head cover (Fig. 49).

i Note

Attach the cylinder head cover within the next 10 minutes.

- Place the cylinder head cover on the cylinder block and tighten the fastening screws.

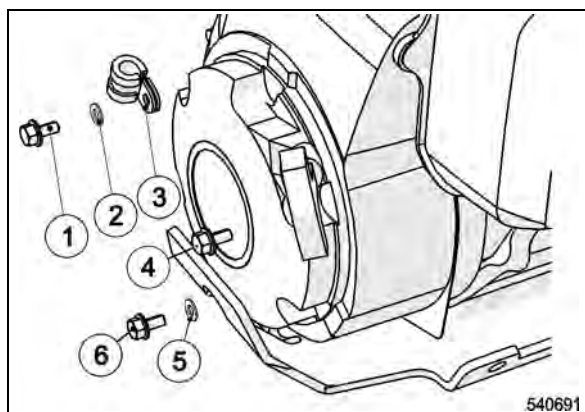

Fig. 50

⚠ Caution

Do not mix up the recoil starter fastening screws by mistake!

Mount the recoil starter to the engine housing:

- Insert the screw M6x12 (1) (Fig. 50) with washer (2) and clamp (3) into the recoil starter.

- Insert the screw M6x16 (6) with washer (5) and engine guard holder into the recoil starter.
- Insert screw M6x8 (4) into the recoil starter.
- Tighten screws (1), (4) and (6).

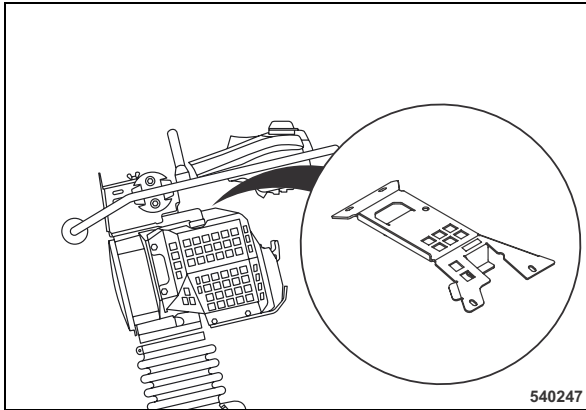

Fig. 51

- Reassemble the top engine cover (Fig. 51).

⚠ Caution

Wait another 20 minutes before starting the engine.

6.13 Replace the fuel filter

⚠ Danger

Fire hazard!

When working on the fuel system do not use open fire, do not smoke. Do not spill any fuel. Shut down the engine.

⚠ Danger

Health hazard!

Do not inhale any fuel fumes.

♻ Environment

Catch running out fuel, do not let it seep into the ground.

Dispose of the used fuel filter environmentally.

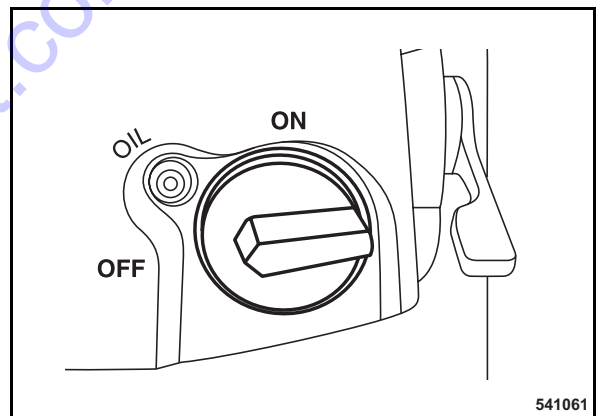

Fig. 52

- Set the engine stop switch (Fig. 52) to position "OFF" (fuel valve closed).

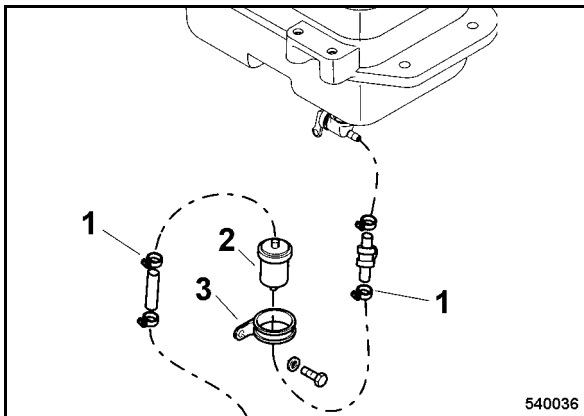

Fig. 53

- Loosen hose clamp (1) (Fig. 53) on the fuel filter and pull off the fuel hoses.
- Loosen the clamping screws (3) and take off the fuel filter (2).
- Install the new fuel filter and observe the flow direction (arrow).
- Fasten the clamp.
- Fasten the fuel hoses to the fuel filter with hose clamps.

6.14 Cleaning the fuel screen

▲ Danger

Fire hazard! Health hazard!

When working on the fuel system do not use open fire, do not smoke, do not spill any fuel. Clean the fuel screen filter only when the engine is cold.

▲ Danger

Health hazard!

Do not inhale any fuel fumes.

♻ Environment

Catch running out fuel, do not let it seep into the ground.

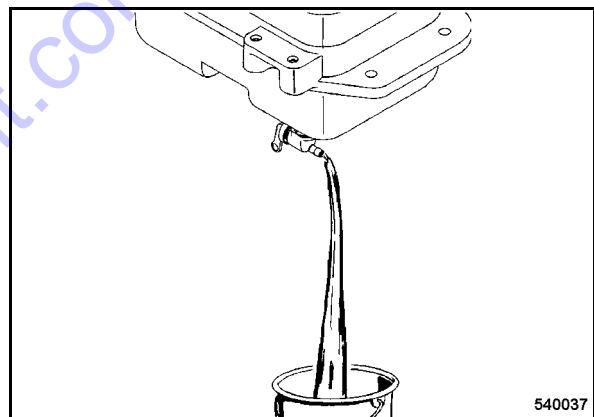

Fig. 54

- Disconnect fuel hose (Fig. 54) from fuel cock. Open the fuel cock, drain off fuel.

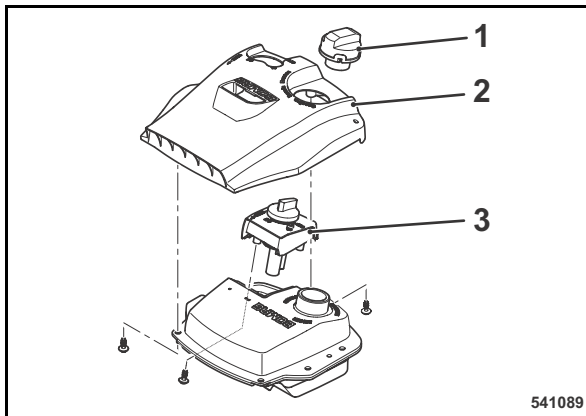

Fig. 55

- Clean the area around the tank cover, unscrew the tank cover (1) (Fig. 55).
- Unscrew 3 fastening screw from the cover (2) and take off the cover.
- Unscrew 3 fastening screws for the engine stop switch and take off the engine stop switch.

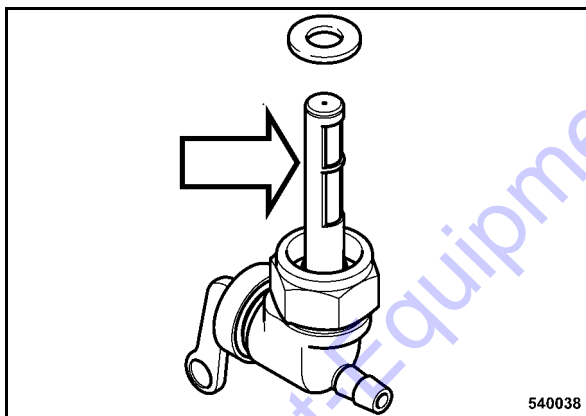

Fig. 56

- Unscrew the fuel valve (Fig. 56).
- Clean the screen grid.
- Check the condition of the screen grid (holes), replace the fuel cock if necessary.
- Screw the fuel cock back in with a new seal.
- Install the engine stop switch again. Retighten the fastening screws with a tightening torque of 10 Nm (7.4 ft.lbs).
- Reassemble the cover. Retighten the fastening screws with a tightening torque of 3 Nm (2.2 ft.lbs).
- Fasten the fuel hose to the fuel valve.

- Close the tank again.

6.15 Check, adjust the engine speed

⚠ Danger

Exhaust gases are highly dangerous!

Always ensure an adequate supply of fresh air when starting and operating in closed rooms and trenches!

⚠ Danger

Danger of accident!

Examine the starter rope of the recoil starter for chafing before starting, replace if necessary. A damaged rope can break and cause injuries during starting.

Always hold on to the machine.

Keep your feet away from the tamper plate, because the vibration starts immediately.

Always keep an eye on a running machine.

⚠ Danger

Loss of hearing!

Wear your personal noise protection means (ear defenders) before starting operation.

Checking the engine speed

Idle speed: 1850 to 2000 min⁻¹.

Maximum speed: 3850 to 4200 min⁻¹.

i Note

Before checking the engine speeds you should change the air filter and check the engine oil level.

- Start the engine.

i Note

Run the tamper on ground that can be compacted.

Run the engine for approx. 15 minutes to warm up.

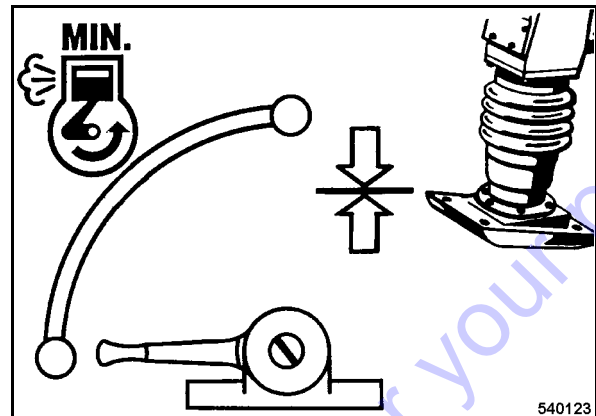

Fig. 57

- To read the idle speed set the throttle lever to position MIN (Fig. 57).

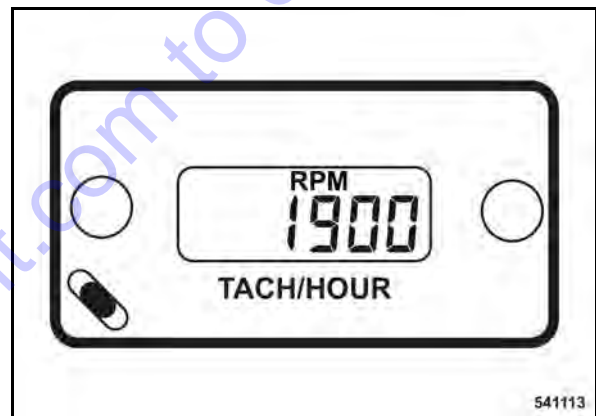

Fig. 58

- After approx. 30 to 40 seconds read the idle speed from the existing engine rpm-meter (Fig. 58).

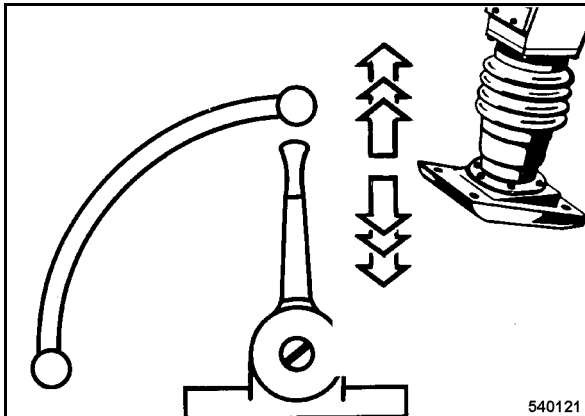

Fig. 59

- To read the maximum speed set the throttle lever to position MAX (Fig. 59).
- After approx. 30 to 40 seconds read the idle speed from the existing engine rpm-meter (Fig. 58).

Adjusting the engine speed

- Shut down the engine.

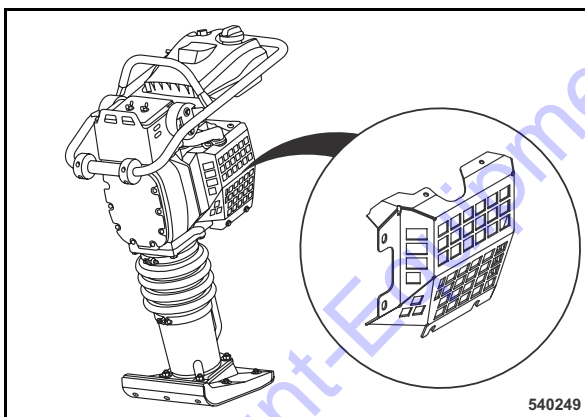

Fig. 60

- Remove the protection grid on the left hand side of the engine ((Fig. 60)).

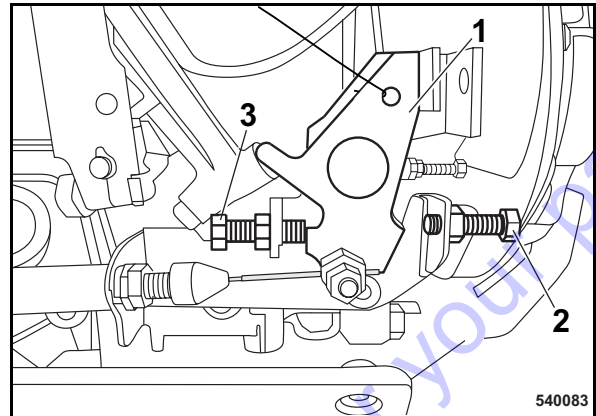

Fig. 61

- Adjust the idle speed using the rear stop screw (2) on the engine speed control lever (1) (Fig. 61).
- Adjust the maximum speed by the front stop screw (3).
- Secure the stop screws (2, 3).
- Assemble the protection grid on the left hand side of the engine.

i Note

Adjust the throttle cable, if this should be necessary.

6.16 Replacing the starter rope

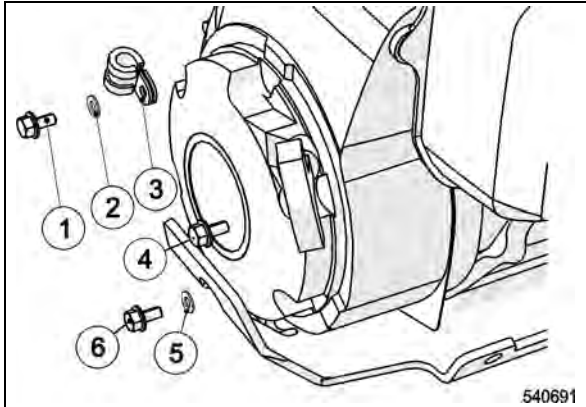

Fig. 62

⚠ Caution

Do not mix up the recoil starter fastening screws by mistake!

- Unscrew the fastening screws (1), (4) and (6) (Fig. 62) and take off the recoil starter.

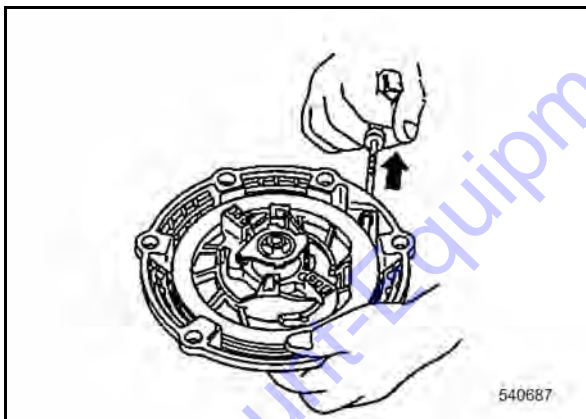

Fig. 63

- Pull the starter rope with the starter handle out completely (Fig. 63).

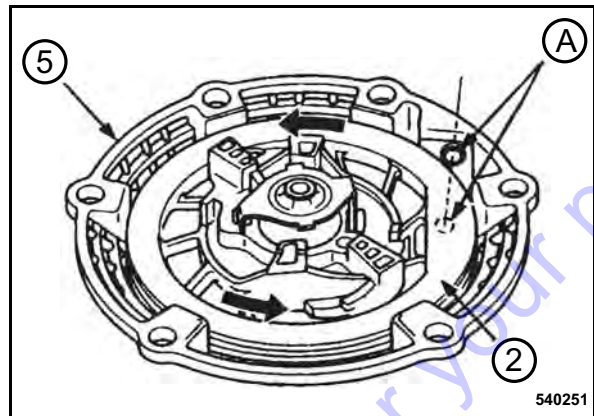

Fig. 64

If the starter rope has been torn or the coil has re-coiled completely:

- Before assembling the rope turn the coil (2) (Fig. 64) 5 revolutions in anti-clockwise direction and align the rope openings in coil and housing (5) to each other (A).

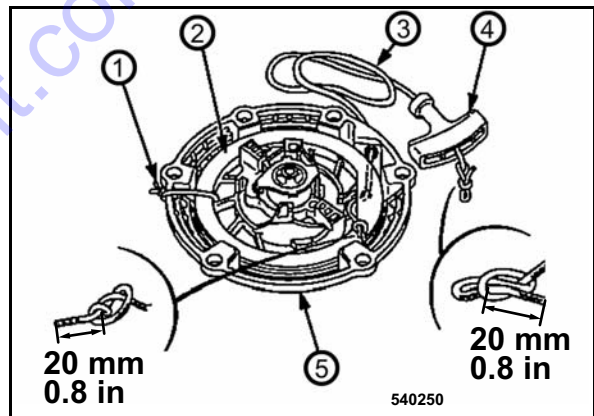

Fig. 65

- Secure the coil (2) (Fig. 65) against winding up. For this purpose fix coil and housing (5) with a cable strap (1).
- Loosen the knots at both ends of the starter rope and remove the old starter rope.
- Thread in the new starter rope (3) and fix it with knots on both ends.

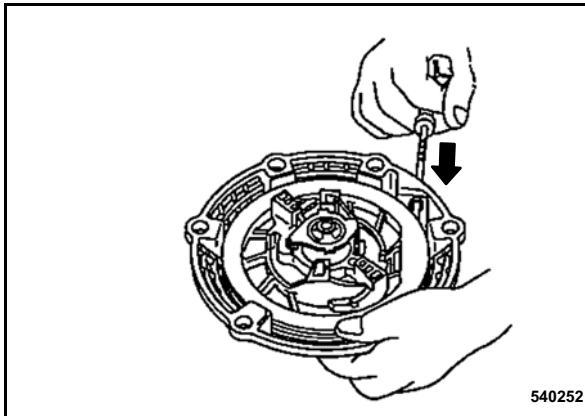

Fig. 66

⚠ Danger

Danger of injury!

Do not let the starter handle hit back, but guide it back slowly.

- Release the coil again and guide the starter handle slowly back to initial position (Fig. 66).
- Test function and light movement of the recoil starter by pulling the starter handle.

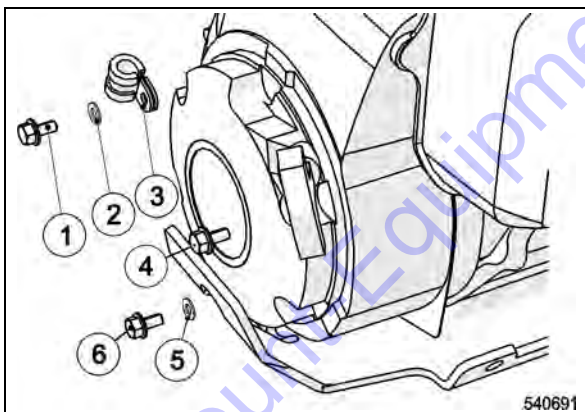

Fig. 67

⚠ Caution

Do not mix up the recoil starter fastening screws by mistake!

Mount the recoil starter to the engine housing:

- Insert the screw M6x12 (1) (Fig. 67) with washer (2) and clamp (3) into the recoil starter.
- Insert the screw M6x16 (6) with washer (5) and engine guard holder into the recoil starter.

- Insert screw M6x8 (4) into the recoil starter.
- Tighten screws (1), (4) and (6).

6.17 Oil change in tamper foot

⚠ Caution

Ensure strict cleanliness.

Change the oil at operating temperature.

For quality and quantity of oil refer to the "table of fuels and lubricants".

♻ Environment

Catch running out old oil, do not let it seep into the ground and dispose off environmentally.

- Tip the tamper backwards.

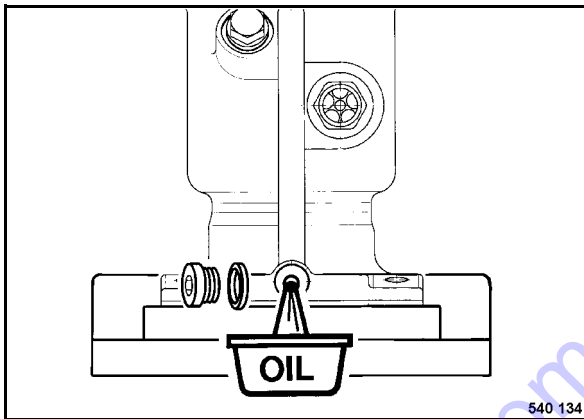

Fig. 68

- Clean and unscrew the oil drain plug (Fig. 68), let the old oil run out and catch it.
- Check the seal on the drain plug, replace if necessary.
- Turn the drain plug in and tighten it.

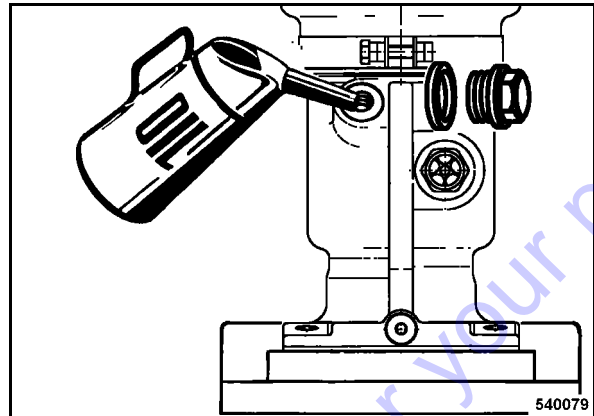

Fig. 69

- Stand the tamper on its foot and secure it against tipping over.
- Clean the filler plug (Fig. 69) and unscrew it.
- Fill in new oil.
- Screw the filler plug back in with a new seal ring.

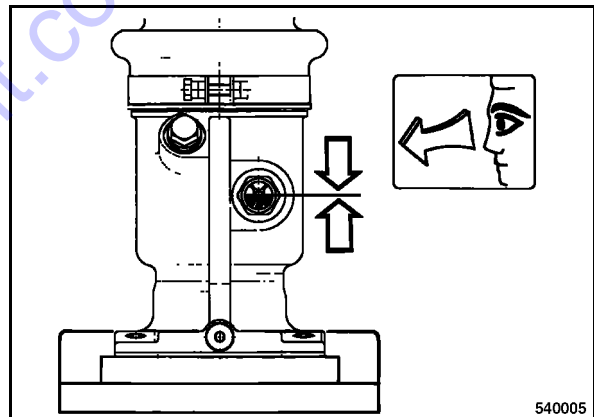

Fig. 70

- Clean the inspection glass (Fig. 70) and check the oil level.
- The oil must be visible in the inspection glass, if necessary fill in oil accordingly.

6.18 Check, clean the air filter, replace if necessary

⚠ Caution

Do not run the engine without air filter.

Do not continue to use a damaged air filter. If in doubt use a new air filter.

Contamination of the air filter depends mainly on the proportion of dust in the intake air, if necessary clean every day.

In case of wet or sticky contamination replace the air filter.

Replace the air filter after several times cleaning, but at the latest after one year.

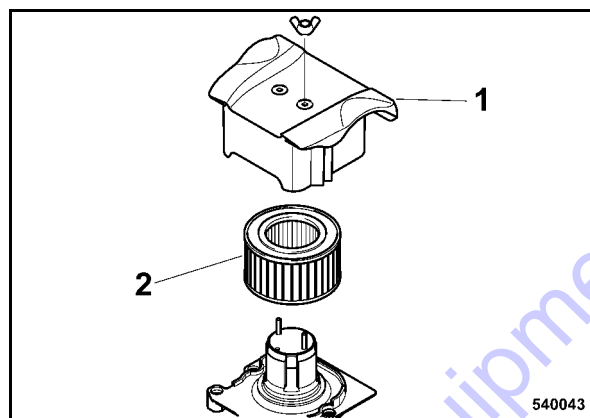

Fig. 71

- Remove cover (1) (Fig. 71), carefully take out the air filter (2).

⚠ Caution

Make sure that no dirt falls into the air intake channel.

⚠ Danger

Danger of injury!

Always wear protective clothes (goggles, gloves) when working with compressed air.

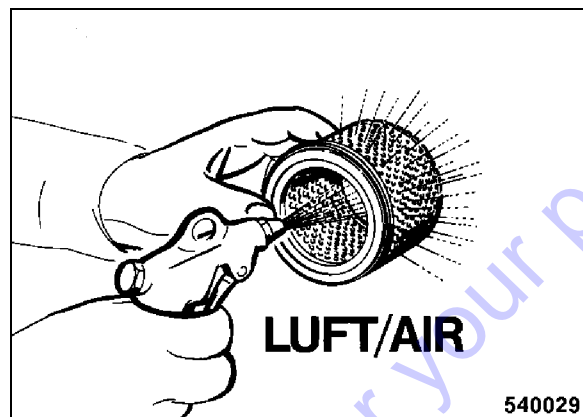

Fig. 72

- In case of dry fine dust blow out the filter cartridge carefully from inside to outside with dry, clean compressed air (Fig. 72) (max. 6 bar (87 psi)).

⚠ Caution

Before installation check seals and air filter for damage, replace if necessary.

- Insert the air filter (2) (Fig. 71) and close the air filter cover.

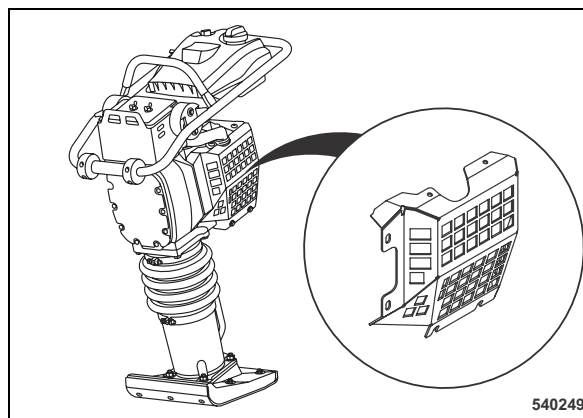

Fig. 73

- Remove the protection grid on the left hand side of the engine (Fig. 73).

As required

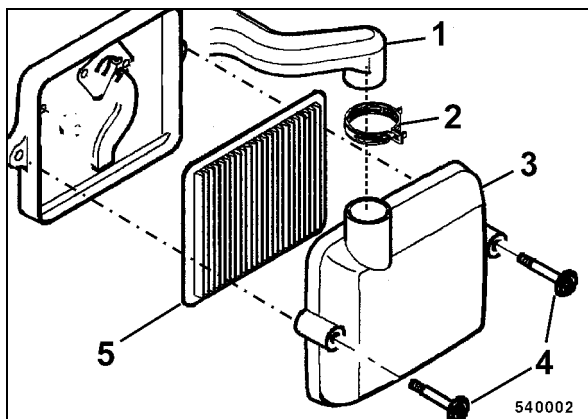

Fig. 74

- Loosen hose clamp (2) (Fig. 74) and pull the air supply hose (1) off the air filter housing.
- Unscrew two fastening screws (4) and remove cover (3) from the air filter housing.
- Pull the air filter (5) out of the housing.
- Wipe the inside of the air filter housing only with a clean cloth.

Caution

Make sure that no dirt falls into the air intake channel.

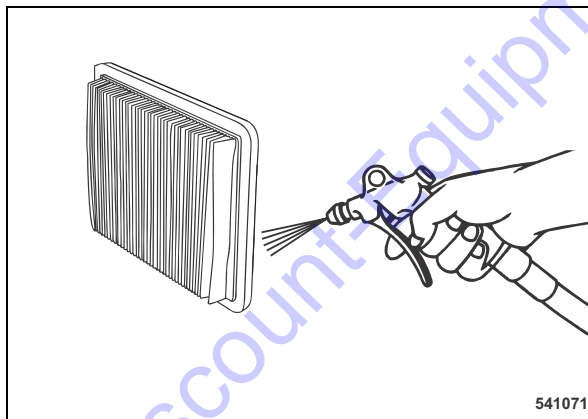

Fig. 75

- In case of dry fine dust blow out the air filter carefully from inside to outside with dry, clean compressed air (Fig. 75) (max. 2 bar (29 psi)).
- In case of excessive contamination or damage replace the air filter.

Caution

Before installation check seals and air filter for damage, replace if necessary.

- Assemble the air filter (5) (Fig. 74) and tighten the cover (3).
- Connect the air guide hose (1) to the air filter housing and tighten the hose clamp (2).
- Assemble the protection grid on the left hand side of the engine.

7 Trouble shooting

7.1 General notes

Please observe strictly the safety regulations in the corresponding section of these operating and maintenance instructions.

Malfunctions are frequently caused by incorrect operation of the machine or insufficient maintenance. Whenever a fault occurs you should therefore thoroughly read these instruction on correct operation and maintenance.

If you cannot locate the cause of a fault or rectify it yourself by following the trouble shooting chart, you should contact our customer service department.

Go to Discount-Equipment.com to order your parts

7.2 Engine problems

Fault	Possible cause	Remedy
Engine does not start	Fuel tank empty	Check the fuel level, top up if necessary.
	Fuel system clogged	Clean the fuel screen in the tank Replacing the fuel filter Clean the fuel screen in the carburettor
	Fuel nozzle clogged	Clean the fuel nozzle
	No ignition spark	Clean the spark plug, replace if necessary
	Engine oil level too low	Check the engine oil level, correct if necessary
Engine does not crank when operating the recoil starter	Set the engine stop switch to position "OFF"	Set the engine stop switch to position "ON"
	Engine stop switch defective	Replace the engine stop switch
	No fuel in carburettor	Check the fuel supply
Starter rope of recoil starter does not return to initial position	Recoil starter defective	Replace the recoil starter
	Spring broken	Replace the recoil starter
Engine stops frequently in short intervals	Recoil starter dirty	Clean the recoil starter
	Spring broken	Replace the recoil starter
Engine does not run with full speed	Fuel system clogged	Clean the fuel screen in the tank Replacing the fuel filter Clean the fuel screen in the carburettor
Engine does not run with full speed	Throttle cable defective	Replacing the throttle cable
	Throttle cable incorrectly adjusted	Adjust the throttle cable
	Air filter clogged	Clean the air filter, replace if necessary
	Too high engine oil level	Check the engine oil level, if necessary drain off engine oil to the "MAX" mark (Clean the air intake manifold)
	Exhaust blocked	Clean the exhaust
	Engine defective	Have examined by a specialist
	Carburettor defective	Have examined by a specialist
Engine runs with high speed, but no vibration	Centrifugal clutch defective	Replacing the centrifugal clutch
	Mechanical defect	Have repaired by our customer service.

8 Disposal

8.1 Final shut-down of machine

If the machine can no longer be used and needs to be finally shut down you must carry out the following work and have the machine disassembled by an approved specialist workshop.

Environment

Catch all fuels and lubricants, do not let them seep into the ground and dispose of in compliance with legal regulations.

- Empty the fuel tank.
- Drain lubrication oil from engine and tamper foot.

Danger

Danger of explosion!

Parts that previously contained combustible fluids must not be cut with a cutting torch.

PARTS FINDER

**Search Website
by Part Number**



**Search Manual
Library For Parts
Manual & Lookup Part
Numbers – Purchase
or Request Quote**

**Can't Find Part or
Manual? Request Help
by Manufacturer,
Model & Description**

Discount-Equipment.com is your online resource for quality parts & equipment.

Florida: **561-964-4949** Outside Florida TOLL FREE: **877-690-3101**

Need parts?

Click on this link: <http://www.discount-equipment.com/category/5443-parts/> and choose one of the options to help get the right parts and equipment you are looking for. Please have the machine model and serial number available in order to help us get you the correct parts. If you don't find the part on the website or on one of the online manuals, please fill out the request form and one of our experienced staff members will get back to you with a quote for the right part that your machine needs.

We sell worldwide for the brands: Genie, Terex, JLG, MultiQuip, Mikasa, Essick, Whiteman, Mayco, Toro Stone, Diamond Products, Generac Magnum, Airman, Haulotte, Barreto, Power Blanket, Nifty Lift, Atlas Copco, Chicago Pneumatic, Allmand, Miller Curber, Skyjack, Lull, Skytrak, Tsurumi, Husquvarna Target, Stow, Wacker, Sakai, Mi-T-M, Sullair, Basic, Dynapac, MBW, Weber, Bartell, Bennar Newman, Haulotte, Ditch Runner, Menegotti, Morrison, Contec, Buddy, Crown, Edco, Wyco, Bomag, Laymor, EZ Trench, Bil-Jax, F.S. Curtis, Gehl Pavers, Heli, Honda, ICS/PowerGrit, IHI, Partner, Imer, Clipper, MMD, Koshin, Rice, CH&E, General Equipment, Amida, Coleman, NAC, Gradall, Square Shooter, Kent, Stanley, Tamco, Toku, Hatz, Kohler, Robin, Wisconsin, Northrock, Oztec, Toker TK, Rol-Air, APT, Wylie, Ingersoll Rand / Doosan, Innovatech, Con X, Ammann, Mecalac, Makinex, Smith Surface Prep, Small Line, Wanco, Yanmar