



# SERVICE/PARTS MANUAL

MODELS: 655PM, 755PM, 855PM



## CHAMPION® PLASTER MORTAR MIXER

A 100% employee-owned American manufacturer

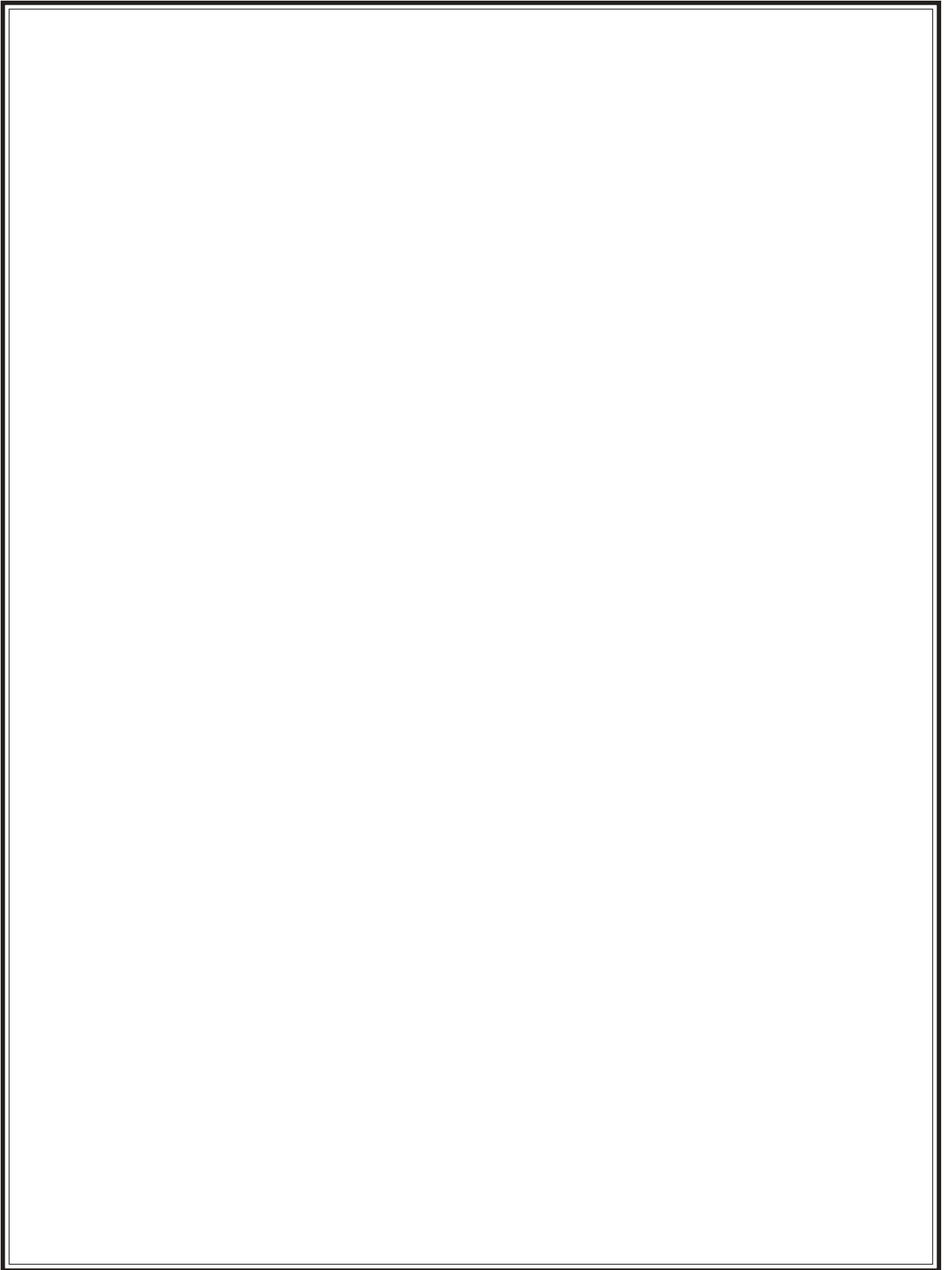

# Table of Contents

655PM, 755PM, 855PM

TABLE OF CONTENTS .....	3-4
USER INFORMATION .....	5
LIMITED WARRANTY .....	6
TECHNICAL DATA .....	7-12
655PM, 755PM, 855PM Specifications .....	7
Machine Sound and Vibration Measurements .....	8
Hardware .....	9
Torque Chart - Imperial .....	10
Torque Chart - Metric .....	11
Location and Use of Controls .....	12
HEALTH & SAFETY .....	13-16
Safety Training .....	13
Safety Precautions .....	14-16
MAINTENANCE.....	16-24
Maintenance Tasks .....	16
Wheel Bearing Lubrication/Wheel Bearing Adjustment/Torque Chart/Towing.....	17
Towing .....	18
Bull Gear Assembly .....	19
Bearing and Seal Installation .....	20
Trailer Lights Option .....	21
Electric Wiring .....	22
Lubrication Schedule .....	23

# Table of Contents

655PM, 755PM, 855PM

DRAWINGS with PART NUMBER BREAKDOWNS .....	25-51
Frame and Drum Assembly .....	26-29
Paddle Assembly .....	30-31
Hand Clutch Assembly .....	32-33
Spiral Blades Assembly .....	34-35
Gas Engine Drive Train .....	36-39
Electric Motor Drive Train .....	40-41
Optional Spring Axle Assembly .....	42-43
Standard Axle Assembly .....	44-45
Trailer Light Assembly .....	46-47
Decal Identification .....	48-49
CALIFORNIA PROPOSITION 65 .....	IBC

# User Information

# Foreword/Service Information

These instructions include:

- Safety regulations
- Operating instructions
- Maintenance instructions

**These instructions have been prepared for operation on the construction site and for the maintenance engineer.**

These instructions are intended to simplify operation of the machine and to avoid malfunctions through improper operation.

Observing the maintenance instructions will increase the reliability and service life of the machine when used on the construction site and reduce repair costs and down-times.

**Always keep these instructions at the place of use of the machine.**

**Only operate the machine as instructed and follow these instructions.**

**Observe the safety regulations as well as the guidelines of the civil engineering trade association. Observe safety rules for the operation of equipment and the pertinent regulations for the prevention of accidents.**

Stone Construction Equipment, Inc. is not liable for the function of the machine when used in an improper manner and for other than the intended purpose.

Operating errors, improper maintenance and the use of incorrect operating materials are not covered by the warranty.

The above information does not extend the warranty and liability conditions of business of Stone Construction Equipment, Inc.

1. Machine Type: \_\_\_\_\_  
Machine S/N: \_\_\_\_\_
2. Engine Type: \_\_\_\_\_  
Engine S/N: \_\_\_\_\_
3. VIN: \_\_\_\_\_
4. Purchase Date: \_\_\_\_\_
5. Dealer/Distributor Information:  
Name: \_\_\_\_\_  
Address: \_\_\_\_\_  
\_\_\_\_\_  
Phone #: \_\_\_\_\_  
Fax #: \_\_\_\_\_
6. Battery  
Manufacturer: \_\_\_\_\_  
Battery Type: \_\_\_\_\_  
Battery S/N: \_\_\_\_\_

**Location of above information:**

1. Information on S/N tag.
2. Information on engine tag.
3. Information on S/N tag - if applicable.
4. Date you purchased machine.
5. Dealer machine was purchased from.
6. Information on battery and battery warranty card.

Stone Construction Equipment, Inc.  
P.O. Box 150, Honeoye, New York 14471  
Phone: (800) 888-9926  
Fax: (716) 229-2363

# Limited Warranty

The Manufacturer warrants that products manufactured shall be free from defects in material and workmanship that develop under normal use for a period of 90 days for concrete vibrators and electric pumps, one year for Rhino®, Bulldog®, Wolfpac Rollers™, trowels, Stompers®, saws, forward plates, engine powered pumps, and 6 months for all other products from the date of shipment. The foregoing shall be the exclusive remedy of the buyer and the exclusive liability of the Manufacturer. Our warranty excludes normal replaceable wear items, i.e. gaskets, wear plates, seals, O-rings, V-belts, drive chains, clutches, etc. Any equipment, part or product which is furnished by the Manufacturer but manufactured by another, bears only the warranty given by such other manufacturer. (The Manufacturer extends the warranty period to "Lifetime" for the drum bearings and seals for the mortar mixers, and agrees to furnish, free of charge, the bearings and seals only upon receipt of the defective parts. The warranty is two years for eccentric bearings on the forward plate compactors, mortar and plaster mixer drums, trowel gearboxes and five years on the Bulldog trench roller eccentric bearings.) A Warranty Evaluation Form must accompany all defective parts. Warranty is voided by product abuse, alterations, and use of equipment in applications for which it was not intended, use of non-manufacturer parts, or failure to follow documented service instructions. The foregoing warranty is exclusive of all other warranties whether written or oral, expressed or implied. No warranty of merchantability or fitness for a particular purpose shall apply. The agents, dealer and employees of Manufacturer are not authorized to make modification to this warranty, or additional warranties binding on Manufacturer. Therefore, additional statements, whether oral or written, do not constitute warranty and should not be relied upon.

The Manufacturer's sole responsibility for any breach of the foregoing provision of this contract, with respect to any product or part not conforming to the Warranty or the description herein contained, is at its option (a) to repair, replace or refund such product or parts upon the prepaid return thereof to location designated specifically by the Manufacturer. Product returns not shipped prepaid or on an economical transportation basis will be refused (b) as an alternative to the foregoing modes of settlement - the Manufacturer's dealer to repair defective units with reimbursement for expenses, except labor, and be reviewed with the Manufacturer prior to repair. A Warranty Evaluation Form must accompany all warranty claims.

Except as set forth hereinabove and without limitation of the above, there are no warranties or other affirmations which extends beyond the description of the products and the fact hereof, or as to operational efficiency, product reliability or maintainability or compatibility with products furnished by others. In no event whether as a result of breach of contract or warranty or alleged negligence, shall the Manufacturer be liable for special or consequential damages including but not limited to: Loss of profits or revenues, loss of use of the product or any associated product, cost of capital, cost of substitute products, facilities or services or claims of customers.

No claim will be allowed for products lost or damaged in transit. Such claims should be filed with the carrier within fifteen days.

Effective April 1, 1998.



Stone Construction Equipment, Inc.  
32 East Main Street, P.O. Box 150  
Honeoye, NY 14471-0150

Phone: 1-800-888-9926 • 1-716-229-5141

Fax: 1-716-229-2363

www.stone-equip.com • e-mail: sceney@mcimail.com

# Technical Data

## 655PM, 755PM, 855PM – Specifications

MODEL	655PM	755PM	855PM
Origin	U.S.A.	U.S.A.	U.S.A.
<b>Dimensions</b> Operating Wt. lbs/Kg	550 / 250	565 / 257	605 / 275
Batch Capacity (Bags)	1 1/2 - 2 bags	2 - 2 1/2 bags	2 1/2 - 3 bags
Batch Capacity cu. ft. / cu. m.	6 / .17	7 / .20	8 / .23
Total Volume cu. ft. / cu. m.	6.9 / .20	8.1 / .23	9.0 / .25
L x W x H in. / cm	64 x 34 x 54 / 163 x 86 x 137	68 x 34 x 54 / 173 x 86 x 137	76 x 34 x 54 / 193 x 86 x 137
<b>Operating System</b> Engine	5 hp B&S / 3.7 kw 5.5 hp Honda / 4.10 kw 6 hp Robin / 4.5 kw 8 hp B&S / 6.0 kw 8 hp B&S I/P / 6.0 kw 8.5 hp Robin / 6.3 kw 8 hp B&S / 6.0 kw 8 hp Honda / 6.0 kw 1 1/2 hp / 1.1 kw Electric	6 hp Robin / 4.5 kw 8 hp B&S / 6.0 kw 8 hp B&S I/P / 6.0 kw 8.5 hp Robin / 6.3 kw 8 hp B&S / 6.0 kw 8 hp Honda / 6.0 kw 1 1/2 hp / 1.1 kw Electric	8 hp B&S / 6.0 kw 8 hp B&S I/P / 6.0 kw 8.5 hp Robin / 6.3 kw 8 hp B&S / 6.0 kw 8 hp Honda / 6.0 kw 10 hp B&S I/C / 7.5 kw 2 hp / 1.5 kw Electric
Drive & Clutch	V-Belt to Gears Front Post Hand Clutch	V-Belt to Gears Front Post Hand Clutch	V-Belt to Gears Front Post Hand Clutch
<b>Standard Features</b> Drum Wrap in. / mm	11 ga. .120 / 3.05	11 ga. .120 / 3.05	11 ga. .120 / 3.05
Drum End in. / mm	7 ga. .179 / 4.55	7 ga. .179 / 4.55	7 ga. .179 / 4.55
Pour Lip in. / mm	7 ga. .179 / 4.55	7 ga. .179 / 4.55	7 ga. .179 / 4.55
Drum Lock in. / mm	automatic (patented)	automatic (patented)	automatic (patented)
Paddles: Number	4	4	4
Mixing Action	Simple figure 8	Simple figure 8	Simple figure 8
Paddle Shaft	1 1/2" / 38.1 mm round	1 1/2" / 38.1 mm round	1 1/2" / 38.1 mm round
Frame/Axle: Tow Pole	Post Gussett, pintle, pin or ball hitch	Post Gussett, pintle, pin or ball hitch	Post Gussett, pintle, pin or ball hitch
Axle - extendible	34" - 46" / 86 - 117 cm	34" - 46" / 86 - 117 cm	34" - 46" / 86 - 117 cm
Tires	4.8 x 12 (high speed)	4.80 x 12 (high speed)	B78 x 13 (high speed)
Cowl:	16 galv., stainless steel hinge, diamond shaped expanded steel vent panels	16 galv., stainless steel hinge, diamond shaped expanded steel vent. panels	16 galv., stainless steel hinge, diamond shaped expanded steel vent. panels
<b>Other Features:</b> Bag Splitter	standard	standard	standard
Safety Guard	lift away, heavy-duty	lift away, heavy-duty	lift away, heavy-duty
Guard Lifter	standard (patented)	standard (patented)	standard (patented)
Safety Chain	standard	standard	standard
<b>Warranty:</b> Warranty Machine	6 months	6 months	6 months
Warranty Drum Bearing	lifetime on patented quadruple bearings and seals	lifetime on patented quadruple bearings and seals	lifetime on patented quadruple bearings and seals
Drum Warranty	2 years	2 years	2 years
<b>Options:</b>	spiral blades	spiral blades 13 in. / 33 cm tire spring axle	spiral blades plastic drums spring axle

# Technical Data

## Machine Sound and Vibration Measurements

### Sound and Vibration Measurements

Sound Pressure Values as measured are per the following:	
Noise 1	Model/Configuration
Sound Pressure	655PM 8hp Honda
Tow pole end	92dBA
Cowl end right side (exhaust)	98dBA
Cowl end back of unit	98dBA
Cowl end left side	94dBA
Sound Pressure measurements were taken with Simpson model 886-2 type 2 meter, calibrated 2/21/97	
Acceleration measurements were taken with Quest Tech model VI-100 meter, calibrated 4/17/96	
Sound and vibration measurements obtained with machine operating at maximum.	
Test date was 7/29/98 with test conditions at 23 degrees Celsius	

\\mktg\stone1\netaldus\pm5\enr\bonnie\bln\sound\_pm.doc



# Technical Data

# Hardware

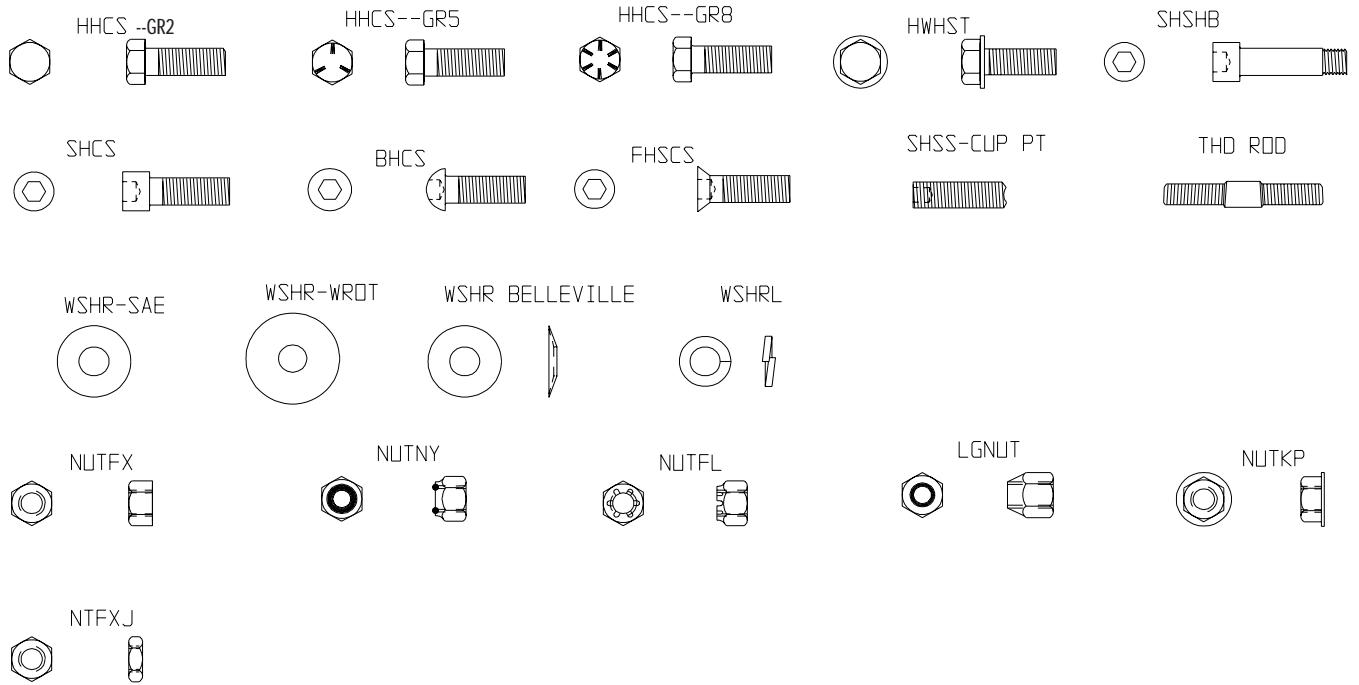

# Technical Data

## Torque Chart - Imperial

### SAE GRADE 5 Coarse Thread

SIZE	PLATED	
1/4 – 20 (.250)	6 ft. lbs.	8 Nm
5/16 – 18 (.3125)	13 ft. lbs.	18 Nm
3/8 – 16 (.375)	23 ft. lbs.	31 Nm
7/16 – 14 (.4375)	37 ft. lbs.	50 Nm
1/2 – 13 (.500)	57 ft. lbs.	77 Nm
9/16 – 12 (.5625)	82 ft. lbs.	111 Nm
5/8 – 11 (.625)	112 ft. lbs.	152 Nm
3/4 – 10 (.750)	200 ft. lbs.	271 Nm
7/8 – 9 (.875)	322 ft. lbs.	436.5 Nm
1 – 8 (1.000)	483 ft. lbs.	655 Nm

### SAE GRADE 8 Coarse Thread

SIZE	PLATED	
1/4 – 20 (.250)	9 ft. lbs.	12 Nm
5/16 – 18 (.3125)	18 ft. lbs.	24 Nm
3/8 – 16 (.375)	33 ft. lbs.	45 Nm
7/16 – 14 (.4375)	52 ft. lbs.	70 Nm
1/2 – 13 (.500)	80 ft. lbs.	108 Nm
9/16 – 12 (.5625)	115 ft. lbs.	156 Nm
5/8 – 11 (.625)	159 ft. lbs.	215 Nm
3/4 – 10 (.750)	282 ft. lbs.	382 Nm
7/8 – 9 (.875)	454 ft. lbs.	615 Nm
1 – 8 (1.000)	682 ft. lbs.	925 Nm

### SAE GRADE 5 Fine Thread

SIZE	PLATED	
1/4 – 28 (.250)	7 ft. lbs.	10Nm
5/16 – 24 (.3125)	14 ft. lbs.	19 Nm
3/8 – 24 (.375)	26 ft. lbs.	35 Nm
7/16 – 20 (.4375)	41 ft. lbs.	56 Nm
1/2 – 20 (.500)	64 ft. lbs.	87 Nm
9/16 – 18 (.5625)	91 ft. lbs.	123 Nm
5/8 – 18 (.625)	128 ft. lbs.	173 Nm
3/4 – 16 (.750)	223 ft. lbs.	302 Nm
7/8 – 14 (.875)	355 ft. lbs.	481 Nm
1 – 12 (1.000)	529 ft. lbs.	717 Nm
1 – 14 (1.000)	541 ft. lbs.	733 Nm

### SAE GRADE 8 Fine Thread

SIZE	PLATED	
1/4 – 28 (.250)	10 ft. lbs.	14Nm
5/16 – 24 (.3125)	20 ft. lbs.	27 Nm
3/8 – 24 (.375)	37 ft. lbs.	50 Nm
7/16 – 20 (.4375)	58 ft. lbs.	79 Nm
1/2 – 20 (.500)	90 ft. lbs.	122 Nm
9/16 – 18 (.5625)	129 ft. lbs.	175 Nm
5/8 – 18 (.625)	180 ft. lbs.	244 Nm
3/4 – 16 (.750)	315 ft. lbs.	427 Nm
7/8 – 9 (.875)	501 ft. lbs.	679 Nm
1 – 12 (1.000)	746 ft. lbs.	1011 Nm
1 – 14 (1.000)	764 ft. lbs.	1036 Nm

# Technical Data

## Torque Chart - Metric

### Property Class 8.8

ZINC-PLATED

SIZE	Coarse Thread		Fine Thread	
	Nm	ft. lbs.	Nm	ft. lbs.
M6	9.9	7	10	7
M8	24	18	25	18
M10	48	35	49	36
M12	83	61	88	65
M14	132	97	140	103
M16	200	148	210	155
M20	390	288	425	313
M24	675	498	720	531

### Property Class 10.9

ZINC-PLATED

SIZE	Coarse Thread		Fine Thread	
	Nm	ft. lbs.	Nm	ft. lbs.
M6	14	10	14	10
M8	34	25	35	26
M10	67	49	68	50
M12	117	86	125	92
M14	185	136	192	142
M16	285	210	295	218
M20	550	406	600	443
M24	950	701	1000	738

### Property Class 12.9

ZINC-PLATED

SIZE	Coarse Thread		Fine Thread	
	Nm	ft. lbs.	Nm	ft. lbs.
M6	16.5	12	16.5	12
M8	40	30	42	31
M10	81	60	82	60
M12	140	103	150	111
M14	220	162	235	173
M16	340	251	350	258
M20	660	487	720	531
M24	1140	841	1200	885

Conversion Factor: 1 ft. lb. = 1.3558 Nm

# Technical Data

## Location and Use of Controls

Before operating this unit, it is important to familiarize yourself, and any other personnel who will be using it, with the location and proper use of the controls to insure safe and efficient operation.

- A. Always make sure that the drum latch is in the lock position (down) before starting up machine. With engine running, turn clutch lever to the right to turn paddles or to the left to stop.



- B. To dump mix from drum, stop paddles, move drum latch up and pull dump handle down. Always use caution when dumping mix.



- C. Always grease drum seals as recommended in the maintenance chart. The grease purges dirt--prolonging bearing life.



- D. Always keep drum and paddles clean. Never run machine with hardened mix or foreign objects in drum--doing so damages paddles and/or engine.



### **SAFETY**

These machines are designed to carry out the function of mixing material of the non-cohesive, bituminous and granular varieties.

If used correctly, they will provide an effective and safe means of mixing and meet the appropriate performance standards.

It is essential that the operator of the machine is adequately trained in its safe operation, be authorized to operate it, and have sufficient knowledge of the machine to ensure that it is in full working order, before being put to use.

# Health & Safety

## Safety Precautions



- Before using this equipment, study the entire Owner's Manual to become familiar with its operation. Do not allow untrained or unauthorized personnel, especially children, to operate this equipment. Use only factory authorized parts for service.



- When warning decals are destroyed or missing, contact the Manufacturer immediately at 1-800-888-9926 for replacement. For the safety of yourself and others, it is imperative that the following rules are observed. Failure to do so may result in serious injury or death.



- This notation appears before warnings in this manual. It means that the following steps must be carried out to avoid the possibility of personal injury or death. These warnings are intended to help the technician avoid potential hazards encountered in normal service procedures. We strongly recommend the reader take advantage of the information provided to prevent personal injury or injury to others.



### **Warning - Loose Hardware**

- With power off, daily check for loose hardware. Immediately inform your supervisor to have it corrected--Do Not Run the Mixer.



### **Warning-Handling Fuel**

- Transport and handle fuel only when contained in approved safety containers.
- Do not smoke when refueling the mixer or during any other fuel handling operation.
- Do not refuel the mixer with the unit running or while hot.
- If fuel is spilled during refueling, wipe it off the engine immediately and discard the rag in a safe place.
- Do not operate the equipment if fuel or oil leaks exist – repair immediately.
- Never operate this equipment in an explosive atmosphere.

# Health & Safety

## Safety Precautions



### Warning-Operating

- Never perform any work on the mixer while it is running.
- Before working on the mixer, stop the engine and unplug/disconnect the spark plug wire(s) to prevent accidental starting. If electric, unplug motor.
- Keep cowl closed during operation.
- Keep hands, clothing and jewelry away from all moving parts.
- Keep all guards in place, including drum guards.
- Never stick your hands or any solid object into the drum while it is in operation.



### Warning-Hot Surfaces

- Avoid contact with hot exhaust system and engines.
- Allow engine to cool before performing any repairs or service.



### Warning-Ventilation

- Never operate any gas powered mixer in a poorly ventilated or enclosed area.
- Avoid prolonged breathing of exhaust gases.



### Warning-Extension Cords

- Always use the proper size grounded extension cord, conforming to the National Electric Code and Local Ordinances.
- Inspect all extension and electrical cords for cuts, frayed wire and broken connectors before use. Do not use cords if not in good condition.
- Do not route extension cords through standing water.
- Do not operate the mixer in standing water.
- When cleaning the mixer, never spray water over the motor.



# Health & Safety

## Safety Precautions



### Warning-Eye Protection

- Always wear splash goggles when operating mixer.



### Warning-Towing

- Warning: Do not tow the mixer with the drum in the dump position. Mixer may become unstable and tip over when hitting a curb, pothole, or other obstruction.



- Warning: Always properly attach safety chains before mixer is towed. Maximum towing speed 65 m.p.h. (105 km/hr). Reduce speed according to highway conditions.



- Never leave mixer unattended while running.
- Mix only Mortar, Plaster, Terrazzo, Fireproofing and Grout.
- Do Not operate machine if rocks, stones, ice or frozen materials are in mix and/or in drum of mixer. The machine could jam, causing damage to the equipment or injury to the operator.



### IMPORTANT

***THE PERSON ATTEMPTING ANY OF THE  
FOLLOWING MAINTENANCE TASKS, MUST BE  
AUTHORIZED TO DO SO AND HAVE READ AND  
UNDERSTOOD ALL SECTIONS WITHIN THIS  
MANUAL***

# Maintenance

## Wheel Bearing Lubrication/Wheel Bearing Adjustment/Hardware/Towing

**WHEEL BEARING LUBRICATION**--Fill wheel hub with grease to inside diameter of outer races and also fill hub grease cap. Never use grease heavier than 265 A.S.T.M. penetration (No. 2 grade). Grease bearing cone by machine or by hand method. Force grease between rollers, cone and cage. (If Ball Bearing Hub: force grease between balls.) It is not recommended that a pressure grease fitting be installed on the hub.

**WHEEL BEARING ADJUSTMENT**--Tighten the adjusting nut with a 12" wrench, at the same time turn the wheel in both directions, until there is a slight bind to be sure all bearing surfaces are in contact. Then back off adjusting nut 1/6 to 1/4 turn or to the nearest locking hole or sufficiently to allow the wheel to rotate freely within limits of 0.001" to 0.010" end play. Lock nut at this position.

**HARDWARE**--Periodically inspect all hardware on the mixer and engine / motor. Loose hardware can contribute to early component failure and poor performance.

**NOTE:** Some hardware is used to retain parts that have to move freely for correct operation of this unit. These items include the guard lifter and drum guard. The hardware for these items should be snug enough to prevent excessive play, yet loose enough to allow the parts to pivot freely.

**TOWING**--Before attempting to tow this mixer, check the state and local laws that apply to your intended route and check the following:

1. Hitch attached to the towing vehicle securely.
2. Tow pole fully extended and bolted to mixer securely.
3. Safety chain hooked up properly (see illustration below or decal on mixer front post).

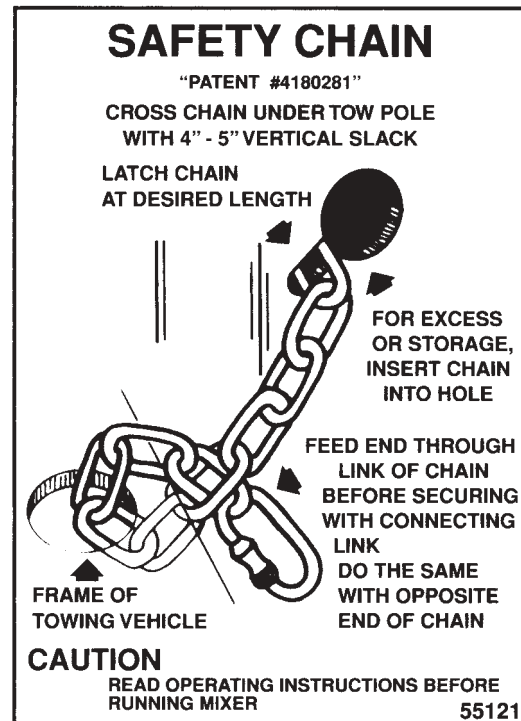

4. Drum in the mixing position and drum latch engaged, clutch lever in the up position.
5. Lug nuts and axle mount nuts tight.

6. On extendible axles, axle extended to full width and adjustment bolts tight.

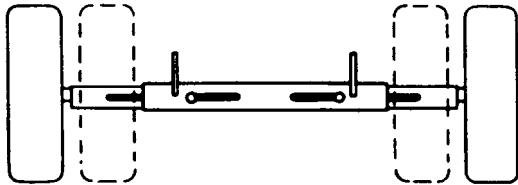

7. On spring axles - spring mounting hardware tight, main springs and snubber springs not cracked or broken.
8. Tires in good shape and at proper inflation, for maximum safety and load capacity tires should be inflated to the following pressures:

Tire size 4.80 x 12 @ 60 P.S.I.

Tire size 6.50 x 13 @ 32 P.S.I.

Refer to FRAME AND DRUM ASSEMBLY, STANDARD AXLE ASSEMBLY and SPRING AXLE ASSEMBLY sections of this manual for parts identification and location.

# Maintenance

## Bull Gear Assembly

### Bull Gear Assembly

1. Align Bull Gear key way opposite to gear mesh.
2. Adjust pinion for tooth alignment and engagement using .010" feeler gage.
3. Tighten all four (4) pillow block bolts before removing feeler gage.

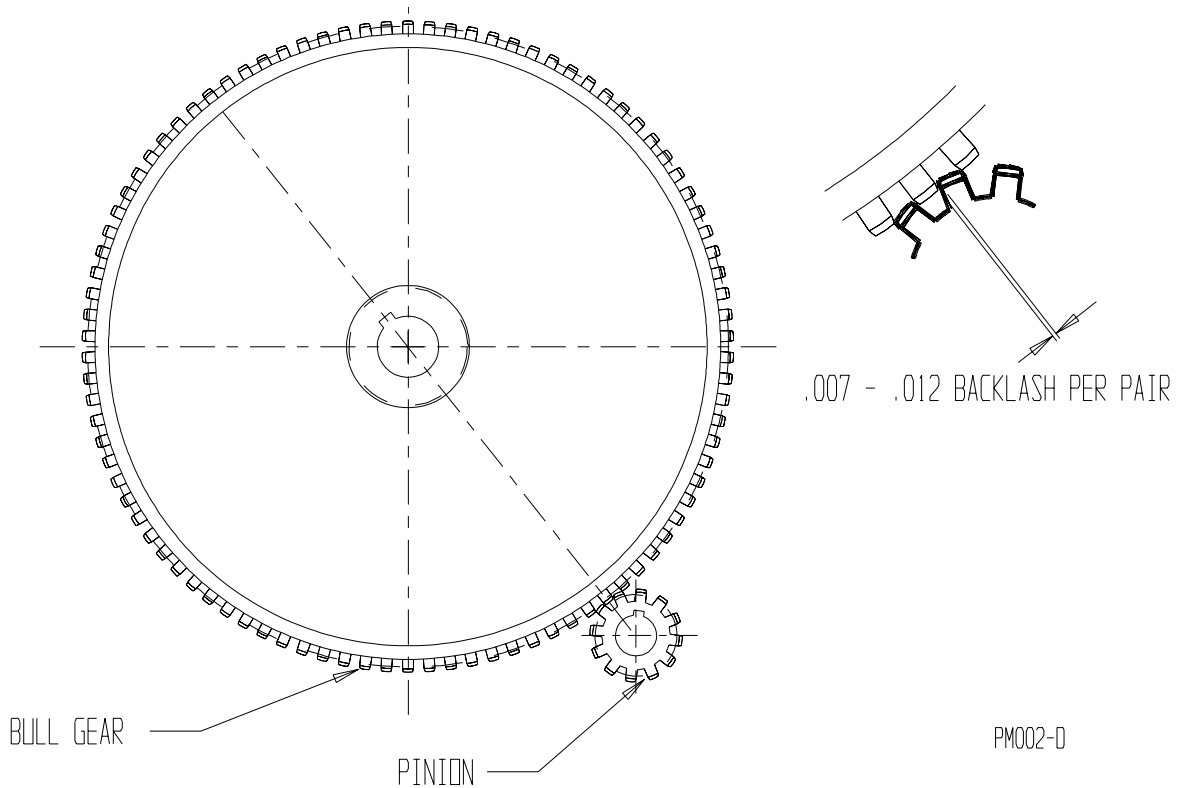

# Maintenance

## Bearing & Seal Installation

**Instructions for Seal & Bearing Assembly Kits  
P/N's 23430 & 23431  
STONE® Mortar Mixers  
465PM, 645PM, 655PM, 755PM, and 855PM**

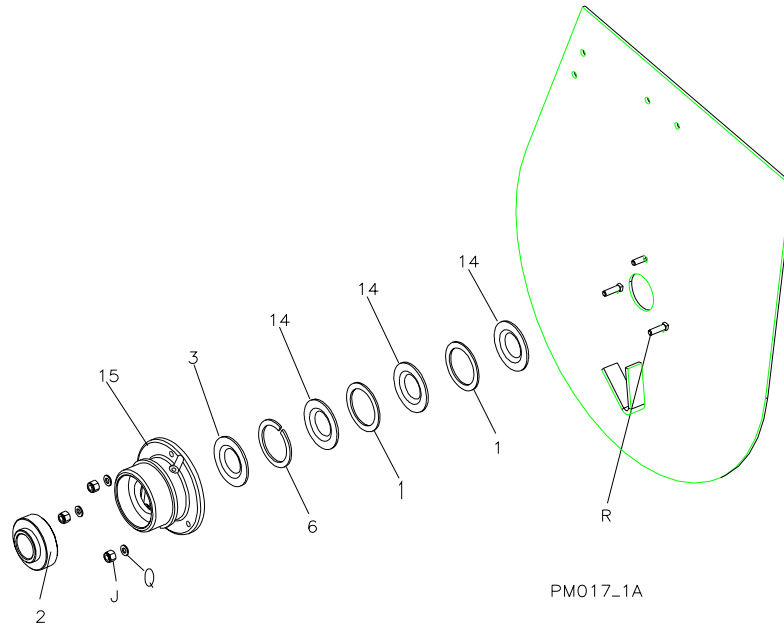

ITEM	P/N	DESCRIPTION	QUANTITY
1	24017	Washer	2
3	24022	Seal Drum Shaft	1
6	25881	Washer Split	1
2	32003	Bearing	1
14	32324	Seal Drum Yellow	3

1. Disassemble drum from frame and remove. Unscrew end bolts from paddle shaft and remove spacers and bull gear.
2. Attach a three-jaw puller to ring on housing, center puller on paddle shaft and remove housing and bearing.
3. Remove worn components and clean shaft and housing as needed.
4. Assemble seals and spacers over paddle shaft, flush with drum end using soapy water mixture as lubricant.
5. Make sure seals are assembled tight up to drum end; inner lip of seals curve inwards towards drum end as illustrated.
6. Insert bearing into housing and slide over shaft and seals as illustrated.
7. Tighten housing evenly to drum end so as not to pinch seals.
8. Reassemble spacer, bull gear (if applicable), washer and bolt to paddle shaft and repeat steps 4-7 on opposite end and reassemble drum to frame.

# Maintenance

## Trailer Lights Option

### Trailer Lights Option--

Before towing this mixer, check that the trailer lights are in proper working condition.



# Maintenance

# Electric Wiring

2 HP ELECTRIC WIRING / 1 PHASE  
 STANDARD WIRING 115 VOLT 24 AMP.  
 FOR 230 VOLT 12 AMP. ROTATE \* DUAL  
 VOLTAGE BOX 180 DEGREE, USE PROPER PLUG

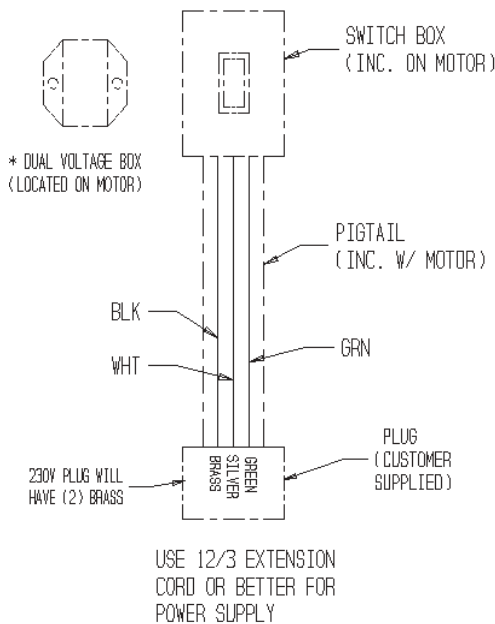

P/N 30168 MOTOR 2HP 115V/230V 1PH  
 MOTOR MFG: BALDOR  
 SPEC NO: 36F283-379

1-1/2 HP ELECTRIC WIRING / 1 PHASE  
 STANDARD WIRING 115 VOLT 18 AMP.  
 FOR 230 VOLT 9.5 AMP. ROTATE \* DUAL  
 VOLTAGE BOX 180 DEGREE, USE PROPER PLUG

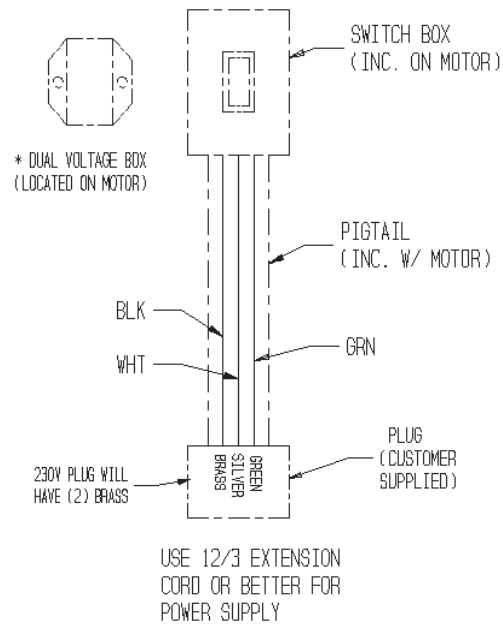

P/N 30167 MOTOR 1-1/2 HP 115V/230V 1PH  
 MOTOR MFG: BALDOR  
 SPEC NO: 36F283-378

# Maintenance

# Lubrication Schedule

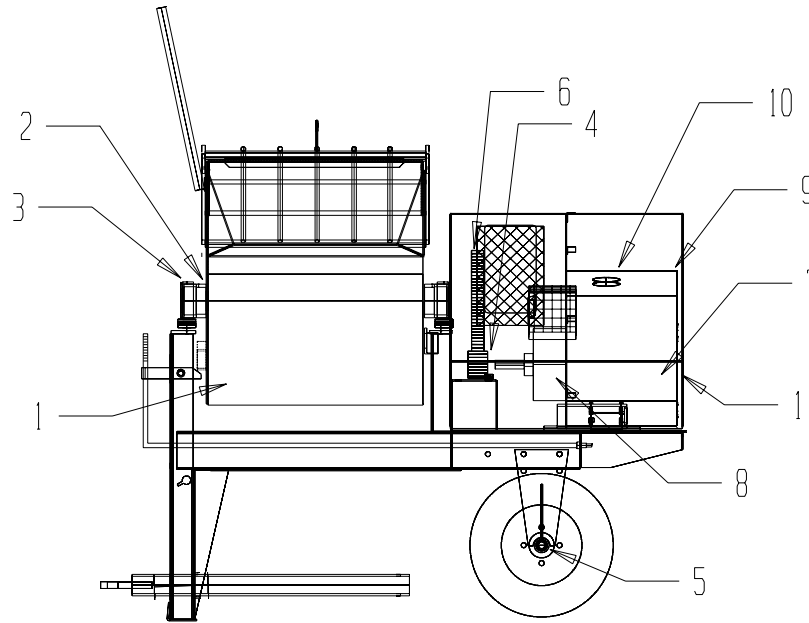

MIXER MAINTENANCE REFER TO MIXER OWNER'S MANUAL PROVIDED PRIOR TO OPERATING OR SERVICING EQUIPMENT	EVERY 5 HOURS OR DAILY	25 HOURS OR EVERY WEEK	50 HOURS OR EVERY MONTH	100 HOURS OR EVERY YEAR
1. MIXER: CLEAN MIXER INSIDE & OUT/REMOVE ALL BUILD UP	CLEAN			
2. DRUM SEALS: GREASE FITTINGS W/ LITHIUM BASE GREASE		GREASE		
3. TRUNNIONS: GREASE FITTINGS W/ LITHIUM BASE GREASE		GREASE		
4. PILLOW BLOCK BEARINGS: W/ LITHIUM BASE GREASE		GREASE		
5. WHEEL HUBS: REPACK EVERY YEAR W/ WHEEL BRG GREASE				EVERY YEAR
6. BULL GEAR: LIGHTLY GREASE EVERY 250 HRS				
<b>ENGINE MAINTENANCE</b> REFER TO ENGINE OWNER'S MANUAL PROVIDED PRIOR TO OPERATING OR SERVICING EQUIPMENT				
7. OIL LEVEL: 40F-110F SAE 30W SE,SF,SG	CHECK		CHANGE *	
BELOW 40F SAE 10W-30 SE,SF,SG	CHECK		CHANGE *	
8. REDUCTION OIL: SAE 30W SE,SF,SG				CHANGE
9. AIR FILTER: PRE-CLEANER WASH IN SOAP & WATER/APPLY OIL ELEMENT CLEAN BY TAPPING		CLEAN **		REPLACE
		CLEAN **		REPLACE
10. SPARK PLUG: CLEAN OR REPLACE			CLEAN	REPLACE
11. COOLING SYS & AIR SCREEN				CLEAN

\* CHANGE OIL AFTER FIRST 5 HOURS, THEN EVERY 50 HOURS  
CHANGE OIL EVERY 25 HOURS UNDER HEAVY LOADS OR HIGH TEMPERATURES  
\*\* CLEAN/CHANGE AIR FILTER MORE OFTEN UNDER DUSTY CONDITIONS

SAFETY 1ST DISCONNECT SPARK PLUG OR ELECTRIC CORD BEFORE SERVICING  
DANGER DO NOT REFUEL WHEN ENGINE IS HOT OR SMOKE WHEN REFUELING  
AVOID PROLONGED BREATHING OF EXHAUST GASES PM004-A



# Drawings and Part Number Breakdowns

Frame and Drum Assembly .....	26-29
Paddle Assembly .....	30-31
Hand Clutch Assembly .....	32-33
Spiral Blades Assembly .....	34-35
Gas Engine Drive Train .....	36-39
Electric Motor Drive Train .....	40-41
Optional Spring Axle Assembly .....	42-43
Standard Axle Assembly .....	44-45
Trailer Light Assembly .....	46-47
Decal Identification .....	48-49

# Part Numbers

# Frame and Drum Assembly

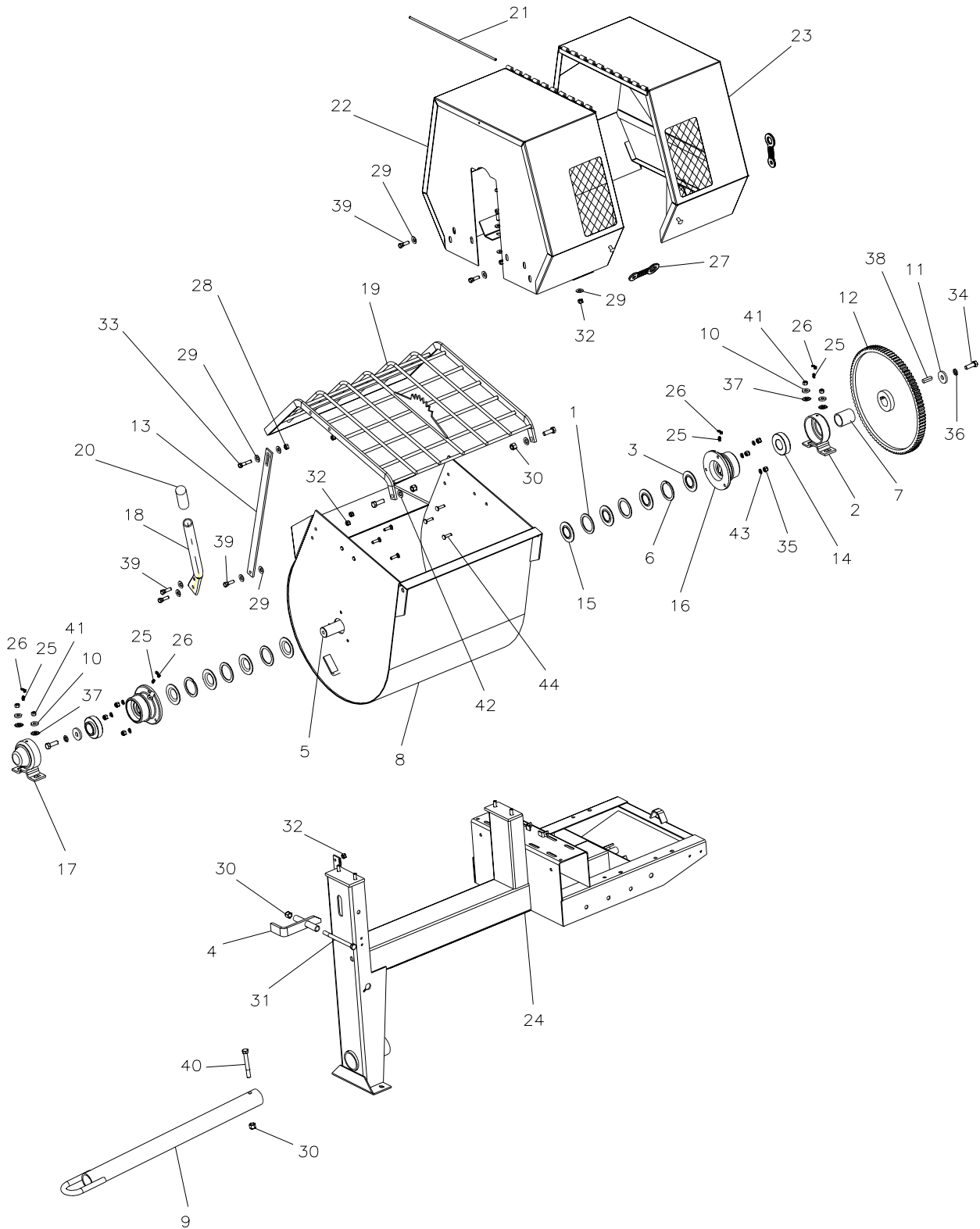

PM012\_1F.dxf

# Part Numbers

## Frame and Drum Assembly

Item	Part No.	Description	Qty.
1	24017	WSHR 2- 15/16 OD x 2-1/4 ID	4
2	24021-2	Weld Trunnion PM EE	1
3	24022	Seal Drum Shaft	2
4	24027-2	Weld Latch Drum	1
5	22336	Kit Paddle Shaft 655PM	1
5b	22337	Kit Paddle Shaft 755PM	1
5c	22338	Kit Paddle Shaft855PM	1
6	25881	Washer Split	2
7	25909	Spacer Shaft EE MdPM	1
8	25934-2	Weld Drum 655PM	1
8b	25922-2	Weld Drum 755PM	1
8c	25943-2	Weld Drum 855PM	1
9	26096-2	Tow Pole	1
10	26325	WSHR .375 ID x 1.00 OD x .187 ZN	4
11	26326	WSHR 9/16 x 1 3/4 x 1/4	2
12	23120	Kit Bull Gear	1
13	28920-2	Lifter Guard	1
14	32003	Bearing	2
15	32324	Seal Drum Yellow	6
16	32326	Housing Bearing Machined	2
17	36574-2	Weld Trunnion Capped TPE	1
18	23179	Handle Dump	1
19	23237	Kit Guard 655PM	1
19b	23238	Kit Guard 755PM	1
19c	23239	Kit Guard 855PM	1
20	44359	Grip Handle Plain	1
21	44368	Pin Hinge 19.50 inches	1
22	44382-2	Cowl Stry MdPM	1
23	44383-2	Cowl Mvbl MdPM/CM	1
24	44386-2	Frame 655PM	1
24b	44387-2	Frame 755PM	1
24c	44388-2	Frame 855PM	1
25	46042	Fitting Grease 1/4 - 28 ZN	4
26	47001	Cap Plug Blue	4
27	47182	Latch Rubber Cowl	3

NOTE: ^ Not Shown

# Part Numbers

# Frame and Drum Assembly

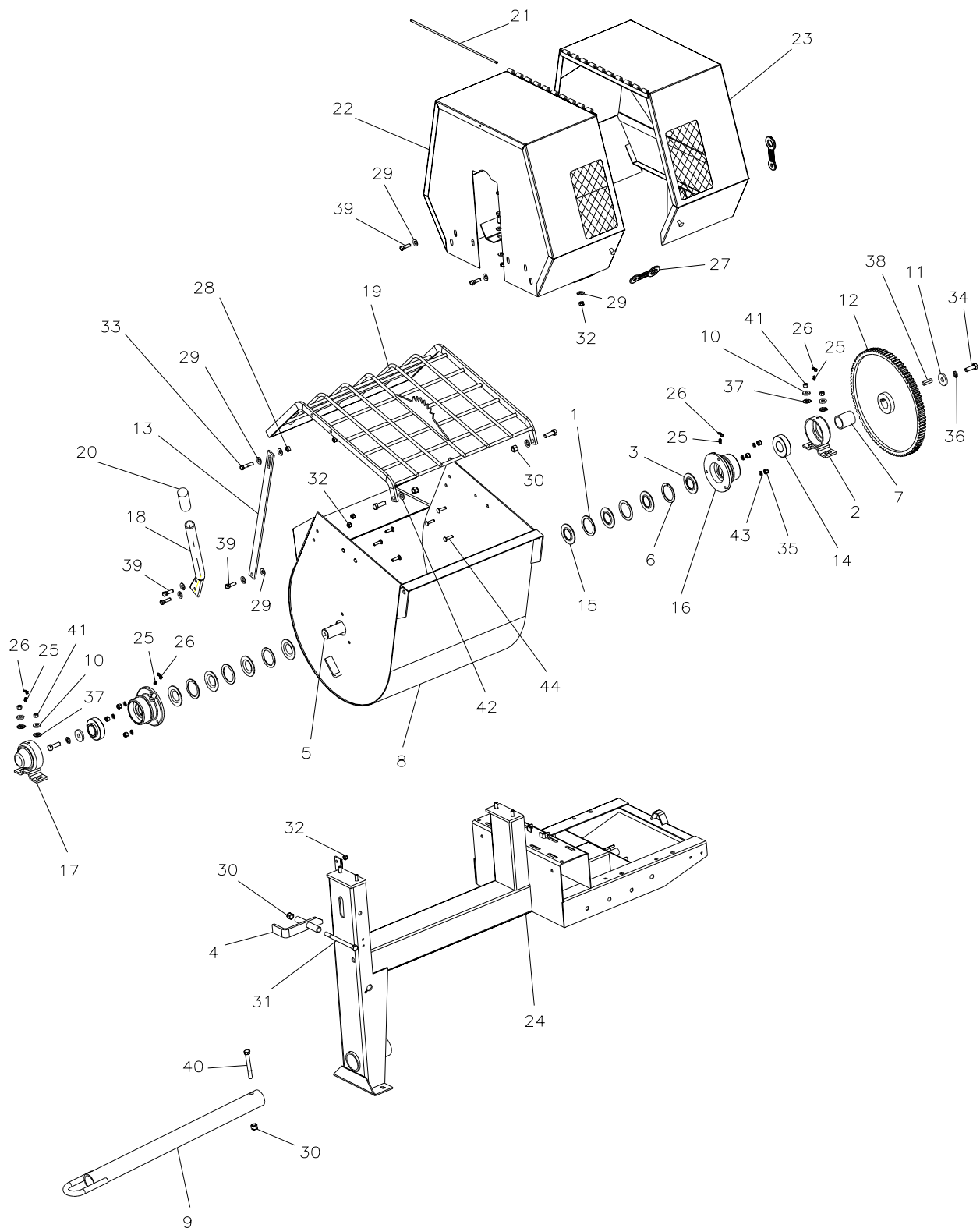

PM012\_1F.dxf

# Part Numbers

## Frame and Drum Assembly

Item	Part No.	Description	Qty.
28	80042	NUTFX 3/8 - 16 ZN	1
29	80043	WSHR WROT 3/8 ZN	18
30	80051	NUTNY 1/2 - 13 ZN	4
31	80052	HHCS 1/2 - 13 x 6 1/2 ZN	1
32	80056	NUTNY 3/8 - 16 ZN	10
33	80072	HHCS 3/8 - 16 x 1-3/4 Gr 5 ZN	1
34	80075	HHCS 1/2 - 13 x 1-1/2 Gr 5 ZN	4
35	80114	NUTNY 5/16 - 18 ZN	6
36	80117	WSHRL 1/2 Med Split ZN	2
37	80119	WSHRLT 3/8 Int/Ext ZN	4
38	80121	Key Sq 3/8 x 1.50 Hard Pln	1
39	80145	HHCS 3/8 - 16 x 1- 14 Gr 5 ZN	9
40	80197	HHCS 1/2 - 13 x 4 GR 8 ZN	1
41	80326	NUTFL 3/8 - 16 1/2 Height	4
42	80343	WSHR SAE 1/2 ZN	2
43	80495	WSHR SAE 5/16 ZN	6
44	81064	CRBLT 5/16 - 18 x 1-1/4	6
^	23221	Kit Cowl Moveable (Includes Items 10, 19, 21 & Decals)	1
^	23193	Kit Cowl Full (Includes Items 10, 19, 20, 21& Decals)	1
^	23431	Kit Bearing Seal (Includes Items 1, 3, 6, 13, 14 (2 sets))	1
^	23430	Kit Seal Spacer (Includes 1, 3, 6, 14 (2 sets))	1
^	21655	Kit Safety Chain	1

Note: ^ Not Shown

# Part Numbers

# Paddle Assembly

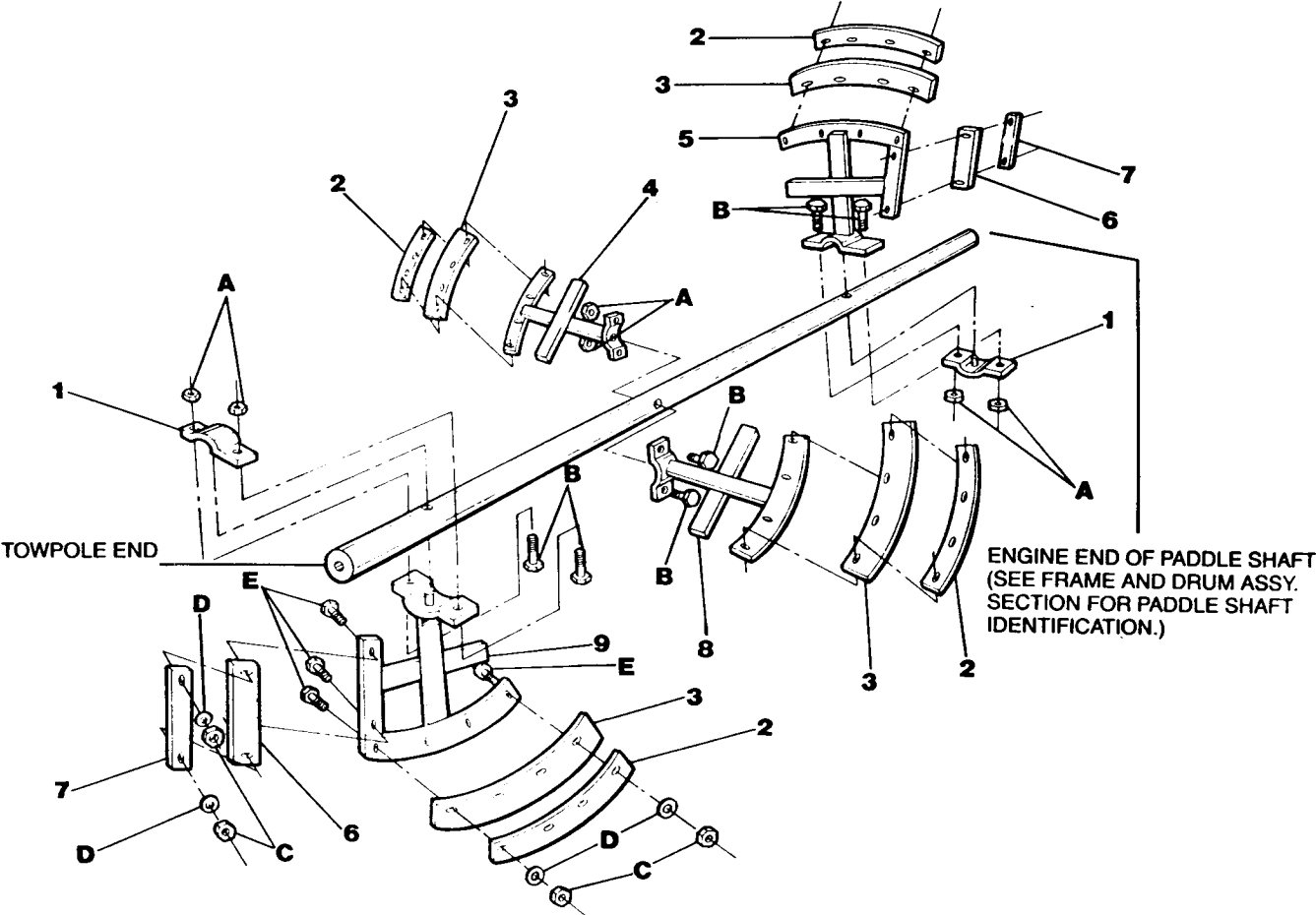

# Part Numbers

## Paddle Assembly

Item	Part No.	Description	Qty.
1	24107-2	Clamp Paddle Weld (655PM, 755PM)	2
1b	24107-2	Clamp Paddle Weld (855PM)	4
2	24104-2	Back Bar Long	4
3	24106	Blade Rubber Long (Optional Steel Blades Available)	4
4	24221-2	Paddle EEC	1
5	24222-2	Paddle EE Weld	1
6	24033	Blade Rubber Short (Optional Steel Blades Available)	2
7	24031-2	Back Bar Short	2
8	24220-2	Paddle TPEC	1
9	24219-2	Paddle TE	1
9b	24109	Blade Steel Long	4
9c	24073	Blade Steel Short	2
A	80051	NUTNY 1/2 - 13 ZN (655PM, 755PM)	6
A2	80051	NUTNY 1/2 - 13 ZN (855PM)	8
B	80089	HHCS 1/2 - 13 X 1-3/4 ZN (655PM, 755PM)	6
B2	80089	HHCS 1/2 - 13 X 1-3/4 ZN (855PM)	8
C	80042	NUTFX 3/8 - 16 ZN	22
D	80043	WSHR 3/8 WROT ZN	22
E	80041	CRBLT 3/8 - 16 X 1-1/4 ZN	22
<b>Blade and Paddle Sets</b>			
^	21047	Set Rubber Blades ( Includes 4-P/N 24106 and 2-P/N 24033)	1
^	23086	Kit Paddle Blades Hardware (Includes Hardware Set C,D & E)	1
^	21065	Set Steel Blades (Includes 4-P/N 24109 and 2-P/N 24073)	1
^	21048	Set Back Bar (Includes 4-P/N 24104-2 and 2-P/N 24031-2)	1
^	21199	Paddle Assembly  (Includes 1-P/N 24219-2, 1-P/N 24220-2, 1-P/N 24221-2, 1-P/N 24222-2, 1-P/N 24031-2, 2-P/N 24033, 4-24104-2, 4-24106, 4-P/N 24107-2))	1
<b>Drum Paddle Assembly (includes drum, paddles and standard blades)</b>			
^	23181	Drum Paddle Assy 655PM	1
^	23182	Drum Paddle Assy 755PM	1
^	23183	Drum Paddle Assy 855PM	1

# Part Numbers

# Hand Clutch Assembly

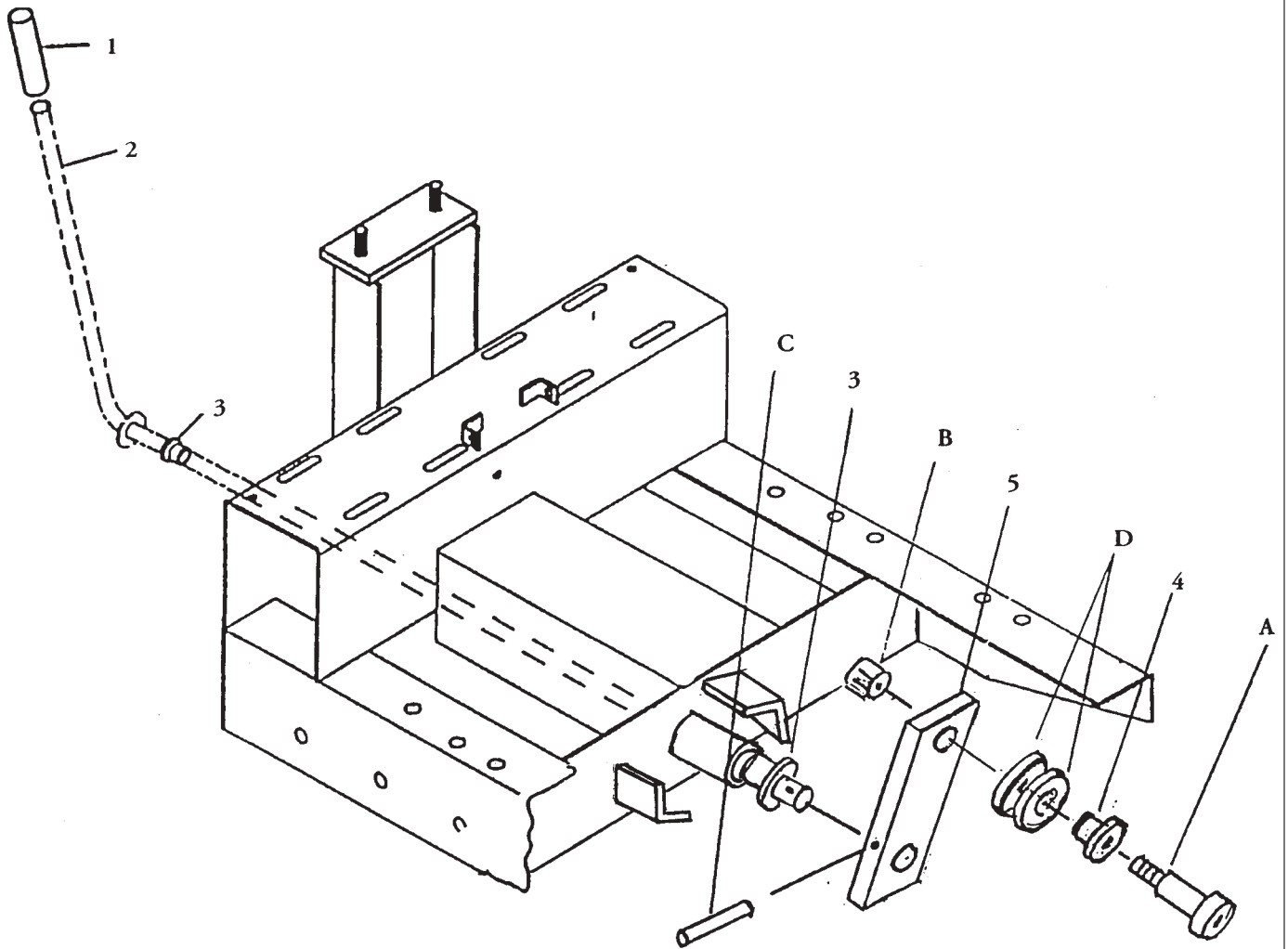

clutch.tif



# Part Numbers

## Hand Clutch Assembly

Item	Part No.	Description	Qty.
1	34687	Grip Handle 0.62	1
2	39568-2	Lever Clutch Hand 655PM	1
2b	39569-2	Lever Clutch Hand 755PM	1
2c	39570-2	Lever Clutch Hand 855PM	1
3	32116	Bushing Flange Nylon 0.62	2
4	32099	Bushing Flange Nylon 0.50	1
5	39446-2	Link Clutch	1
A	80957	SHSHB 1/2 X 1 BLK	1
B	80056	NUTNY 3/8 - 16 ZN	1
C	80775	PINSP 1/4 X 1-1/4 ZN	1
D	26326	WSHR 1-3/4 X 9/16 X1/4	2

# Part Numbers

# Spiral Blades Assembly

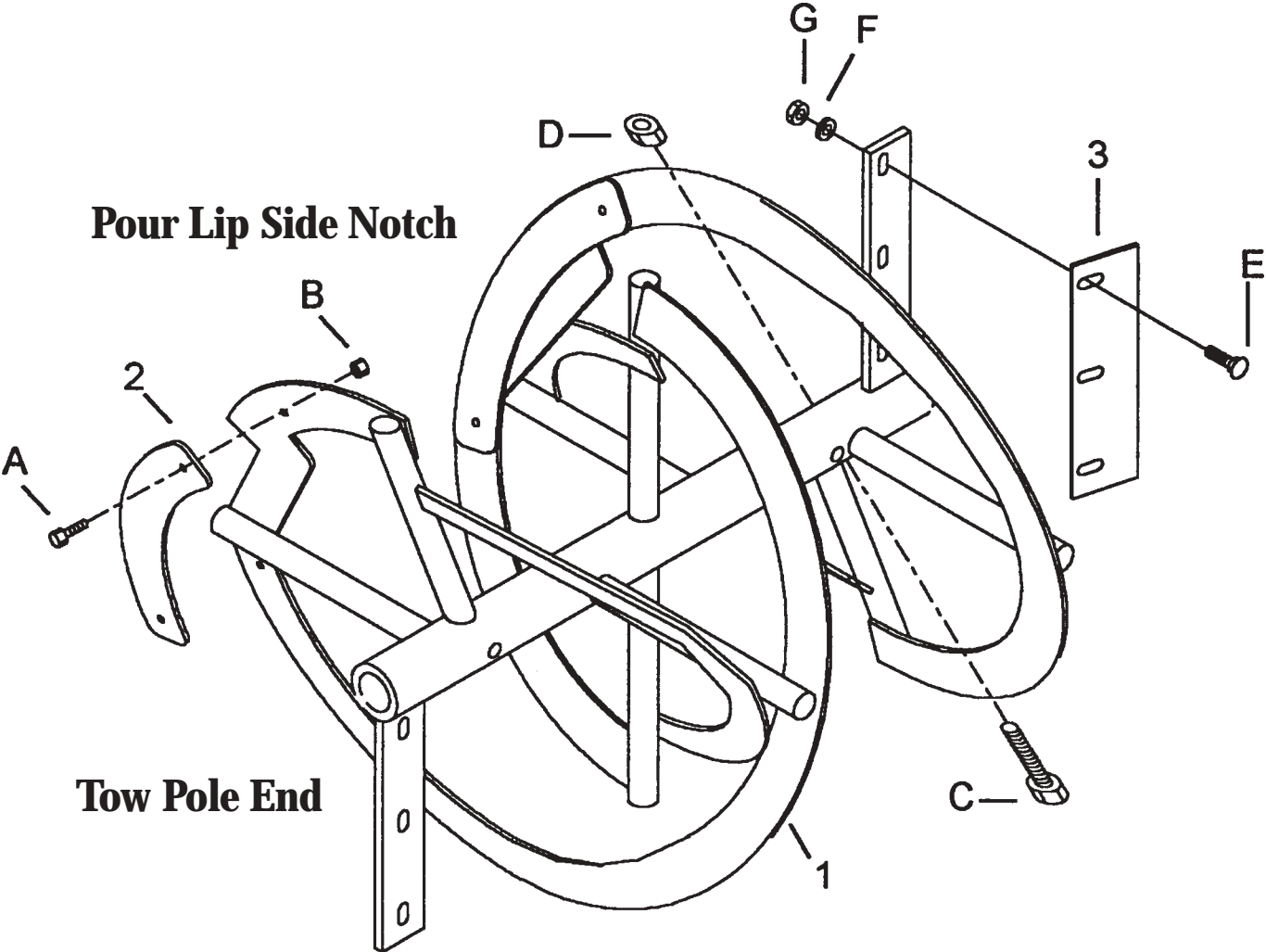

spirabl.tif

# Part Numbers

## Spiral Blades Assembly

Item	Part No.	Description	Qty.
1	42764-2	Spiral Blades--Fillers Included 655PM	1
1b	42755-2	Spiral Blades--Fillers Included 755PM	1
1c	42765-2	Spiral Blades--Fillers Included 855PM	1
2	42801-2	Filler Spiral	2
3	24108-2	Blade End	2
A	80159	HHCS 5/16-18 x 3/4 GR2 ZN	4
B	80114	NUTNY 5/16-18 ZN	4
C	80405	HHCS 1/2-13 x 2-3/4 GR5 ZN	2
D	80051	NUTNY 1/2-13 ZN	2
E	80041	CRBLT 3/8-16 x 1-1/4 ZN	6
F	80043	WSHR 3/8 WROT ZN	6
G	80042	NUTFX 3/8-16 ZN	6

# Part Numbers

# Gas Engine Drive Train

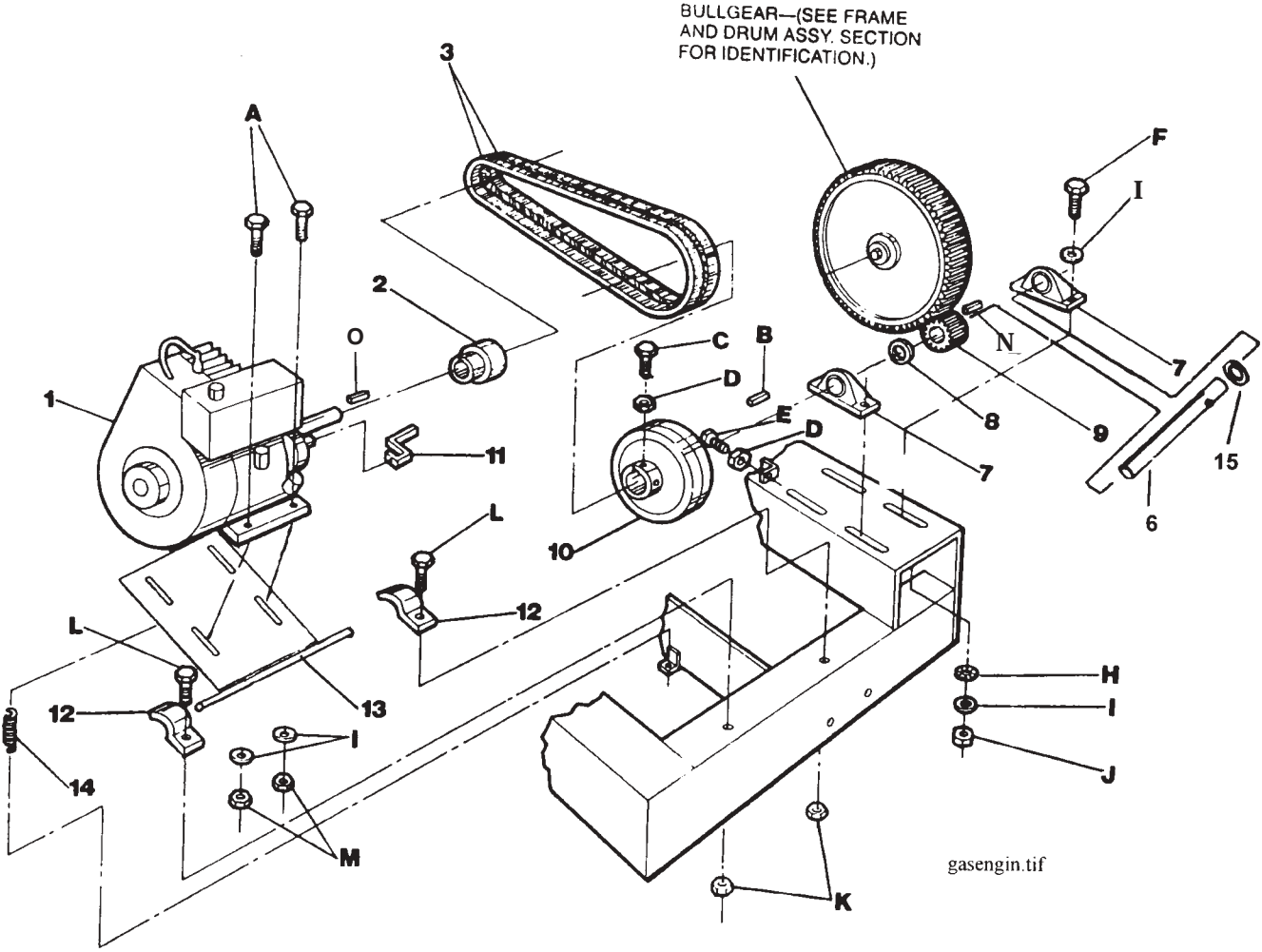

# Part Numbers

## Gas Engine Drive Train

Item	Part No.	Description	Qty.
1	30025	Engine 5hp B&S	1
1b	31213	Engine 5.5hp Honda	1
1c	30596	Engine 6hp Robin	1
1d	30155	Engine 8hp Honda	1
1e	30398	Engine 8hp B&S Kool Bore 6:1Modified	1
1f	30597	Engine 8.5hp Robin	1
1g	30399	Engine 8hp B&S I/P Modified	1
1h	42999	Engine 10hp B&S I/P Modified	1
2	38664	Sheave 4.25 x 3/4 (5 B&S, 5.5 Honda, 6 Robin)	1
2b	38449	Sheave 4.25 x 1 (8H, 8 B&S&I/P, 8.5R,10B&S I/P)	1
2c	34521	Sheave 2AK44 x 3/4 Spiral Blade (5 B&S, 5.5 Honda, 6 Robin)	1
2d	34051	Sheave 2AK44 x 1 Spiral Blade (8.5 R, 8 H, 8 B&S, 8&10B&S I/P)	1
3	34052	V-Belt A-32	2
3b	34617	V-Belt A-28 (Spiral Blade)	2
6	22509	Shaft Assembly	1
7	32208	Pillow Block	2
8	24622	Washer Pinion	2
9	23121	Kit Pinion Gear	1
10	38450	Sheave 8 in	1
10b	35278	Sheave 2AK61 x 1 (Sheave)	1
11	26199-2	Belt Guide (8.5 Robin assembled on opposite side as illustrated)	1
12	27575-2	Bracket Motor Base	2
13	39565-2	Motor Base (5 B&S, 5.5 Honda, 6 Robin)	1
13b	39557-2	Motor Base (8 Honda, 8 B&S, 8 B&S I/P)	1
13c	39443-2	Motor Base ( 8.5 Robin,10 B&S I/P)	1
14	34849	Spring Motor Base	1
15	38122	Washer Retainer Pin	1

Note: Complete Pinion Gas Assembly 21471 (includes Pinion, Shaft and Bearings)

# Part Numbers

# Gas Engine Drive Train

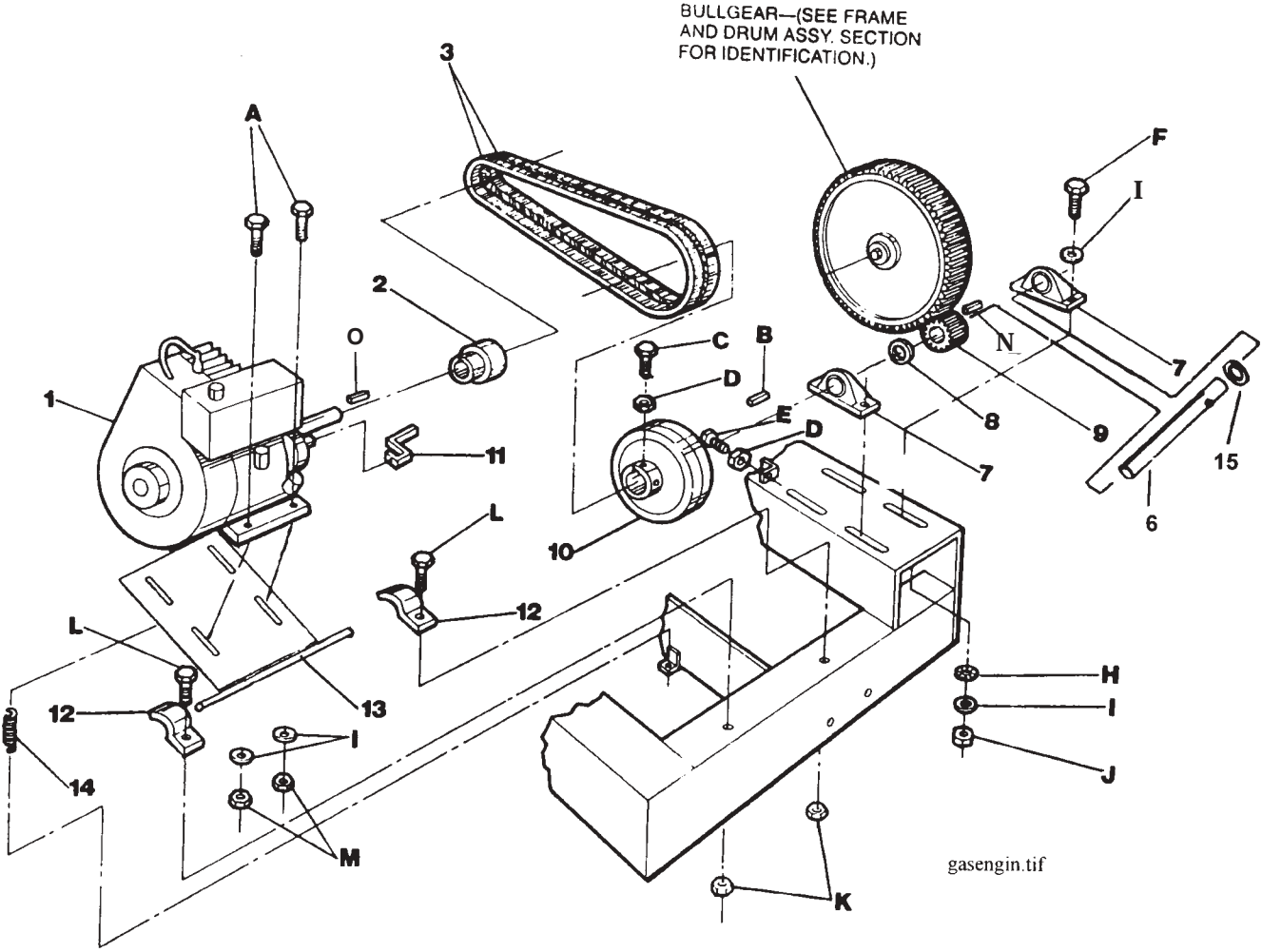

# Part Numbers

## Gas Engine Drive Train

Item	Part No.	Description	Qty.
A	80475	HHCS 5/16 - 18 X 1-3/4 (5 B&S, 5.5 Honda, 6 Robin)	4
A2	80169	HHCS 5/16 - 18 X 2 (8 B&S, 8B&S I/P)	4
A3	80178	HHCS 3/8 - 16 X 2 (8 Honda, 8.5 Robin)	4
A4	80072	HHCS 3/8 - 16 X 1-3/4 (10 B&S I/P)	4
B	80100	KEY, 1/4 X 1	1
C	80258	SQHSS, 5/16 - 18 X 3/4	1
D	80244	NUTFXJ 5/16 - 18	2
E	80164	HHTB 5/16 - 18 X 1-1/2	1
F	80072	HHCS 3/18 - 16 X 1-3/4	4
H	80119	WSHRLT, 3/8 INT/EXT	4
I	26325	WSHR MTR BASE	12
J	80056	NUTNY 3/8 - 16	4
K	80051	NUTNY 1/2 - 13	2
L	80075	HHCS 1/2 - 13 X 1-1/2	2
M	80114	NUTNY 5/16 - 18 (5 B&S, 5.5 Honda, 6 Robin, 8 B&S, 8 B&S I/P)	4
M2	80056	NUTNY 3/8 - 16 (8 Honda, 8.5 Robin & 11 B&S I/P)	4
N	80061	Key Sq 1/4 x 1-1/2	1
O	80060	Key Sq 3/16 x 1 (5.5 B&S, 5 Honda, 6 Robin)	1
O2	80100	Key Sq 1/4 x 1 (8 B&S, 8 B&S IP, 8 Honda, 8.5 Robin, 10 B&S IP)	1

# Part Numbers

# Electric Motor Drive Train

BULLGEAR—(SEE FRAME  
AND DRUM ASSY. SECTION  
FOR IDENTIFICATION.)

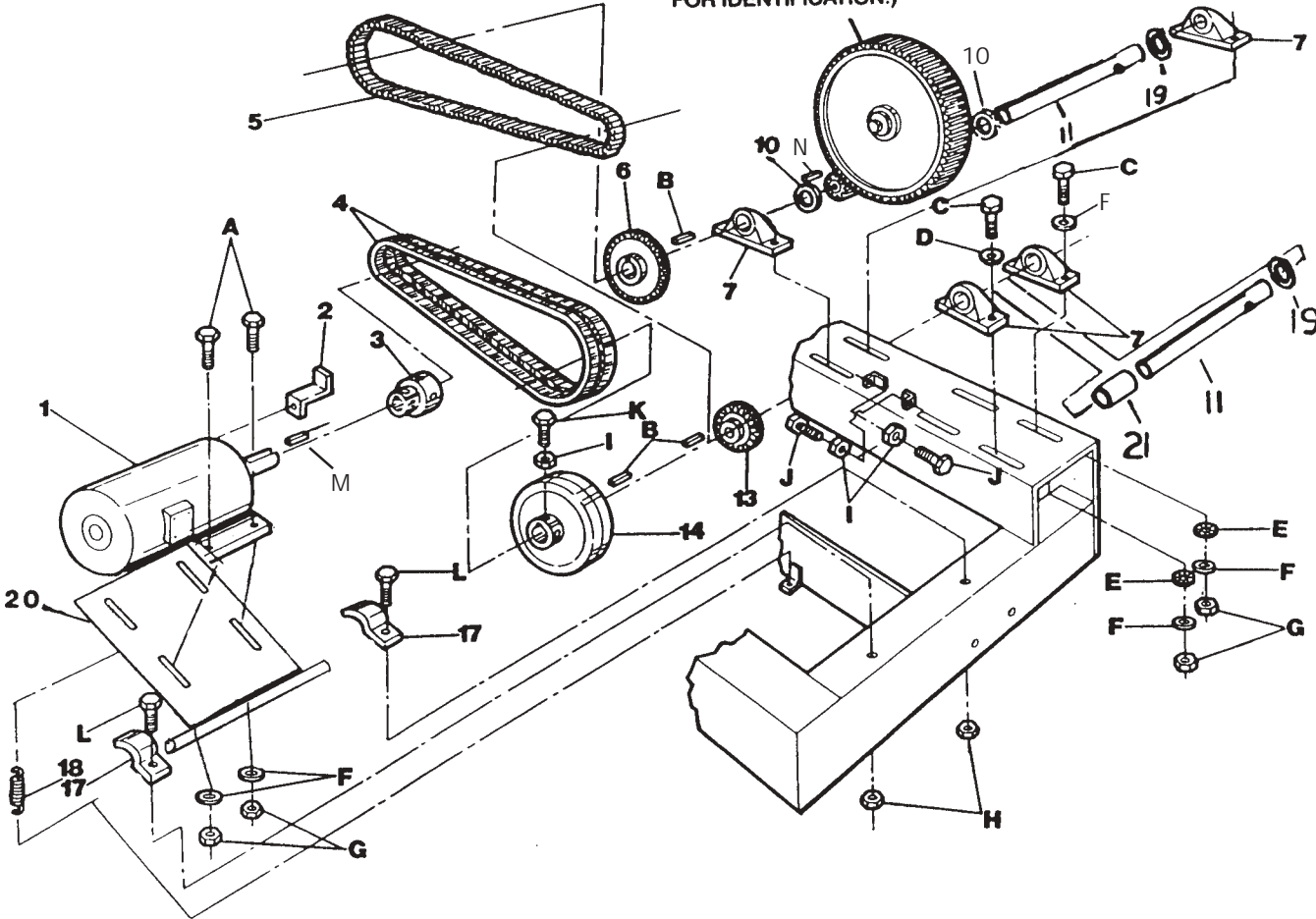

elecmoto.tif



# Part Numbers

## Electric Motor Drive Train

Item	Part No.	Description	Qty.
1	30167	Motor Electric 1.5 hp	1
1b	30168	Motor Electric 2 hp	1
2	42446-2	Belt Guide	1
3	38666	Sheave, 2-1/2 X 7/8	1
3b	34983	Sheave 2AK 30 X 7/8 (Spiral Blade)	1
4	34617	V-Belt A28	2
4b	34159	V-Belt A-30 (Spiral Blade)	2
5	21184	Chain Assembly	1
6	34127	Sprocket 50B 24 X 1	1
7	32208	Pillow Block	4
10	24622	Washer Pinion	4
11	22509	Shaft Assembly	2
13	34126	Sprocket 50B 14 X 1	1
14	38450	Sheave 8 IN.	1
14b	34056	Sheave 2AK 84 X 1 (Spiral Blade)	1
17	27575-2	Bracket Motor Base	2
18	34849	Spring Motor Base	1
19	38122	Washer Retainer Pin	1
20	39567-2	Motor Base	1
21	42966	Spacer Pillow Block	1
22	28826	Threaded Rod	1
A	80145	HHCS 3/8 - 16 X 1-1/4 ZN	4
B	80100	KEY 1/4 X 1	3
C	80072	HHCS 3/8 - 16 X 1-3/4 ZN	8
E	80119	WSHRLT 3/8 INT / EXT ZN	8
F	26325	WSHR 0.375 ID X 10 OD X 0.187 ZN	20
G	80056	NUTNY 3/8 - 16 ZN	12
H	80051	NUTNY 1/2 - 13 ZN	2
I	80244	NTFXJ 5/16 - 18 ZN	3
J	80164	HHTB 5/16 - 18 X 1-1/2 ZN	2
K	80258	SQHSS 5/16 - 18 X 3/4 ZN	1
L	80075	HHCS 1/2 - 13 X 1-1/2 ZN	2
M	80060	Key 3/16 Square	1
N	80061	Key Sq 1/4 x 1-1/2	1

Note: Complete Pinion Assembly 22850 (includes Pinion, Shaft and Bearings) /  
Complete Idler Assembly 21300 (includes Spacer, Shaft and Bearings)

# Part Numbers

# Optional Spring Axle Assembly

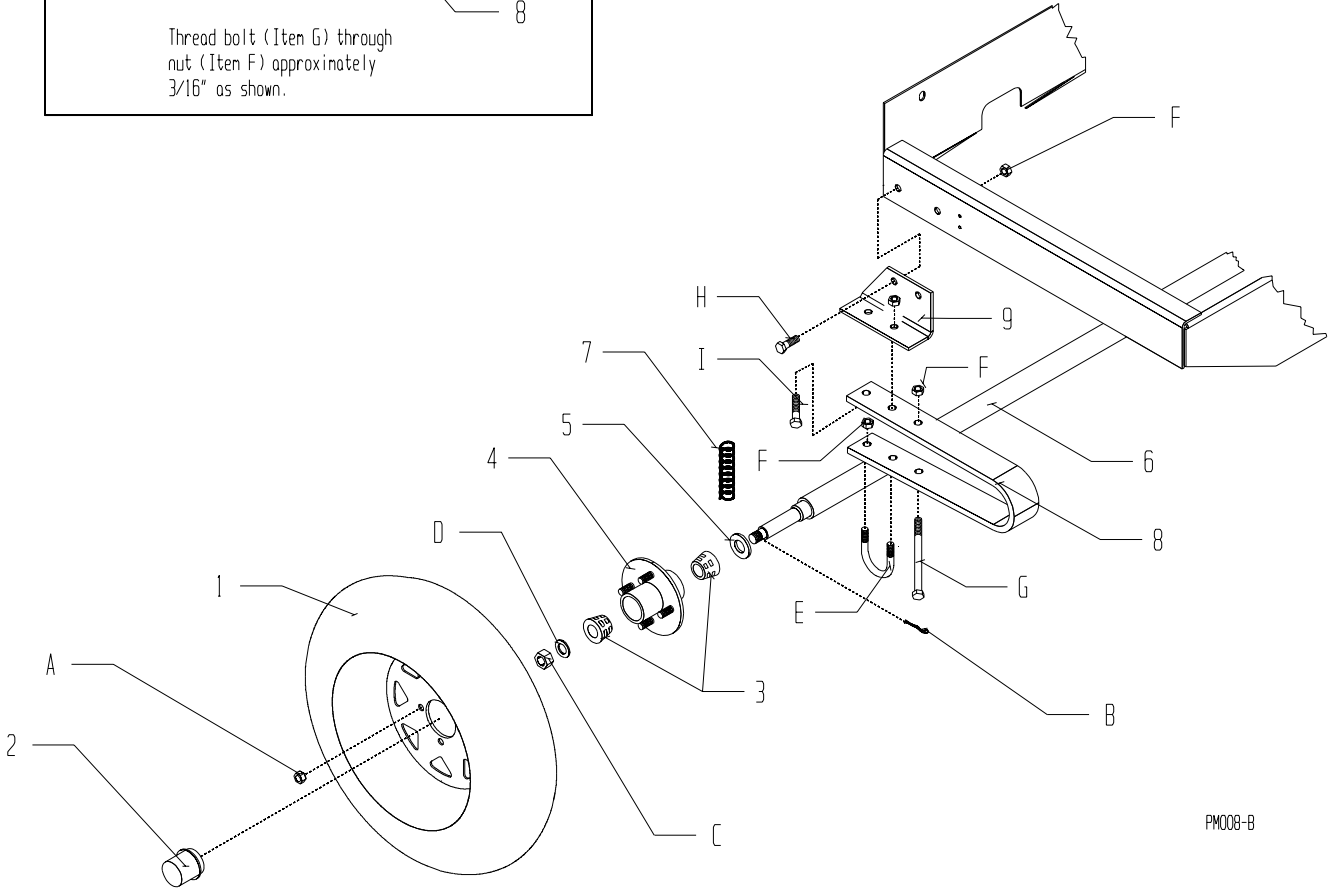
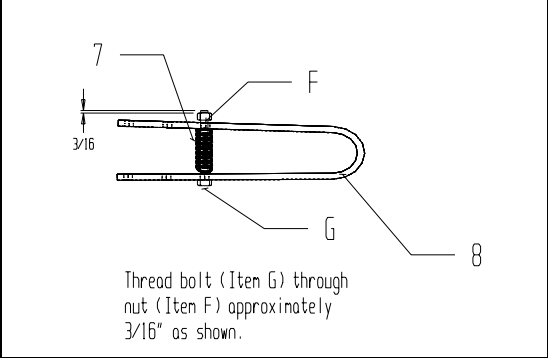

PM008-B

# Part Numbers

## Optional Spring Axle Assembly

Item	Part No.	Description	Qty.
1	32306	Tire and Rim 4.80 X 12 655PM, 755PM	2
1b	32307	Tire and Rim 6.50 X 13 855PM	2
2	34573	Dust Cap	2
3	32051	Bearing Cone	4
4	34501	Hub	2
5	32052	Seal Wheel Hub	2
6	21512-2	Axle Spring Option (655PM, 755PM)	1
6b	21460-2	Axle Spring 56" (855PM)	1
7	34972	Coil Spring	2
8	26971-2	Spring	2
9	26948-2	Bracket Spring Tall (655PM, 755PM)	2
9b	26950-2	Bracket Spring Short (855PM)	2
10^	22162	Axle Assembly 655PM, 755PM (Includes 2,3,4,5,6,C,D)	1
10b^	22037	Axle Assembly 855PM (Includes 2,3,4,5,6,C,D)	1
A	80045	LGNUT 1/2-20 ZN	8
B	80315	PINCT 3/16 X 2 ZN	2
C	80054	NUTFX 3/4-16 ZN	2
D	80344	WSHR 3/4-16 ZN	2
E	26195	U-BOLT	2
F	80051	NUTNY 1/2-13 ZN	16
G	80052	HHCS 1/2-13 X 6-1/2	2
H	80104	HHCS 1/2-13 X 1-1/4	4
I	80089	HHCS 1/2-13 X 1-3/4	4

NOTE:^Not Shown

# Part Numbers

## Standard Axle Assembly

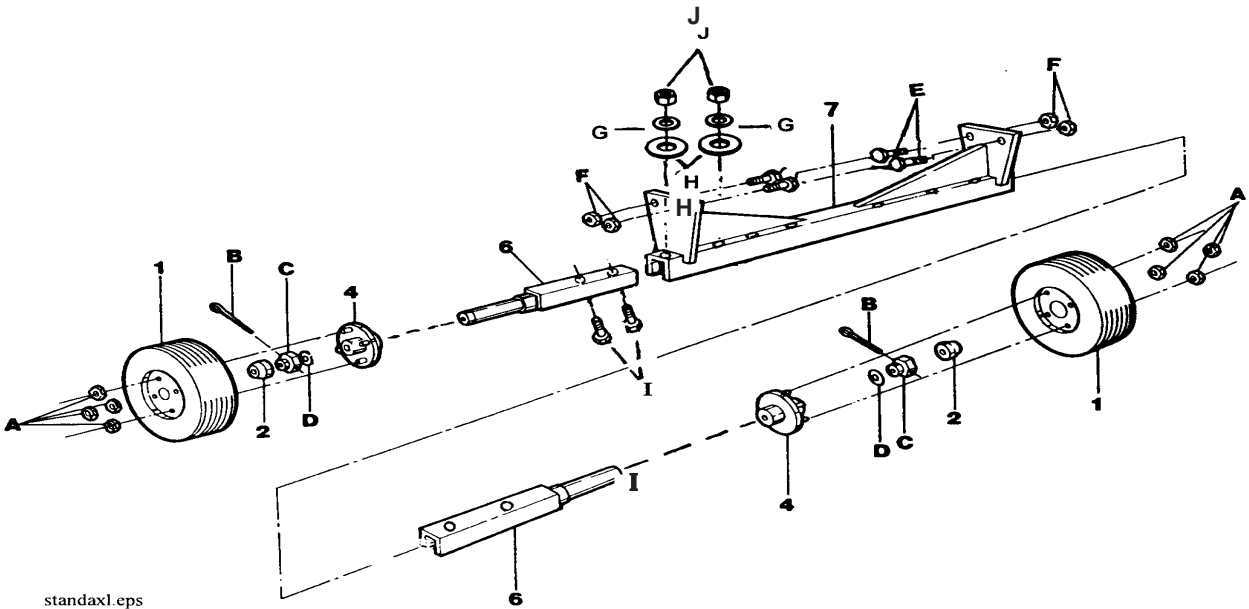

standax1.eps

See **MAINTENANCE** section for proper wheel assembly and **TECHNICAL DATA** section for

See **MAINTENANCE AND LUBRICATION** section for proper wheel assembly and torque specs.

# Part Numbers

## Standard Axle Assembly

Item	Part No.	Description	Qty.
1	32306	Tire and Rim 4.80 X 12 655PM, 755PM	2
1b	32307	Tire and Rim 78 X 13 855PM	2
2	34573	Dust Cap	2
4	34501	Hub 4-Bolt with Tapered Bearing	2
6	22512-2	Half Axle Weld	2
7	22511-2	Axle Support Weld	1
8	21497-2	Axle Assy Complete (Includes 2,4,6,7)	1
A	80045	LGNUT 1/2-20	8
B	80316	PINCT 1/8 X 1-1/2	2
C	80054	NUTSFX 3/4-16	2
D	80344	WSHR 3/4-16	2
E	80075	HHCS 1/2-13 X 1-1/2	4
F	80051	NUTNY 1/2-13	4
G	80117	WSHR 1/2 MED SPLIT	4
H	80118	WSHR 1/2 WROT	4
I	80536	HHCS 1/2-20 X 1-3/4	4
J	80485	NUTNY 1/2-20	4

# Part Numbers

# Trailer Lights

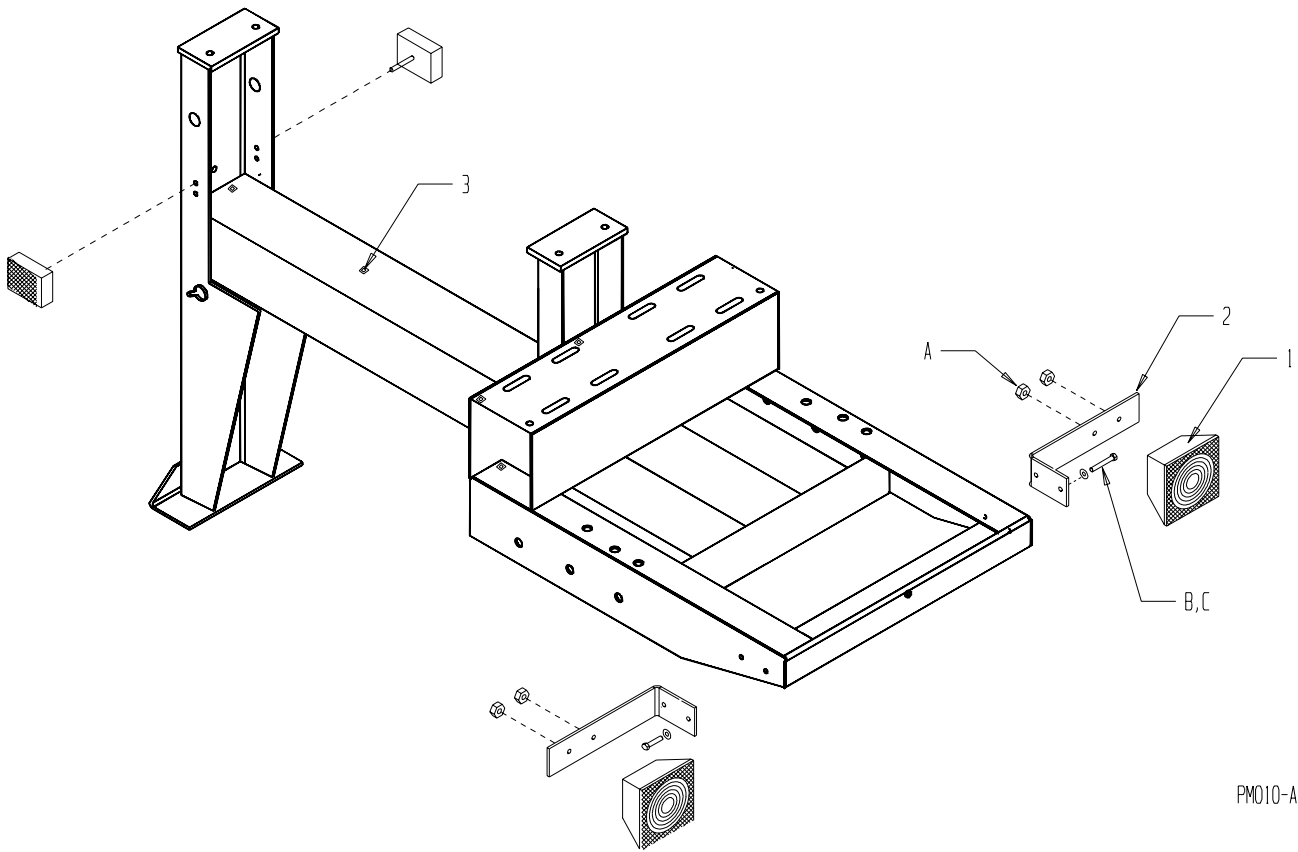

# Part Numbers

## Trailer Lights

Item	Part No.	Description	Qty.
1^	36002	Trailer Lights	1
2	36003	Bracket Trailer Lights	2
3	48329	Tie Holder	10
4^	32087	Bushing Nylon 5/16 ID x 3/8 OD	1
5^	47303	Tie Tyton 4 inch Black	10
6^	48278	Term Fem .25 F-insul 14-16 gage	4
7^	48285	Term Male .25 F-insul 14-16 gage	4
8^	36001	Kit Trailer Lights (Includes 1,2,3,4,5,6,7,A,B,C)	1
A	80236	NUTKP 1/4 - 20 ZN	10
B	80347	WSHR 1/4 WROT ZN PL	4
C	80354	HHCS 1/4-20 x 1.00 ZN	4

# Part Numbers

# Decal Identification

**WARNING**



Do not run machine with cover open.

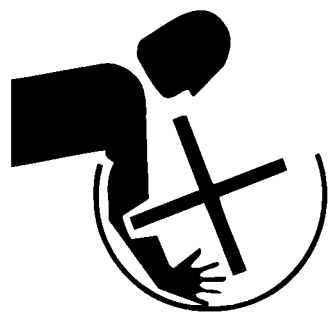

**WARNING**

Shut off machine to service or clean.

55010

**WARNING**

Always stop engine when cleaning or adjusting machine. If electric motor pull plug.

**CAUTION**



**FOR YOUR SAFETY**

- Read owner's service manual before operating or servicing this machine.
- Always keep unauthorized, inexperienced, untrained people away from this machine.
- Rotating and moving parts will cause injury if contacted. Make sure guards and safety devices are in place before this machine is operated.
- Make sure engine is shut down and spark plug wire disconnected before servicing the machine or approaching the moving parts- if electric motor, disconnect plug.
- Never leave machine unattended when operating. Always stop engine or motor before adding fuel or oil.

**NOTICE**

Contact the manufacturer immediately at 1-800-888-9926 if safety or hazard decals or owner's manual are missing from this equipment.



**DANGER**

**GASOLINE**  
Stop engine and extinguish all flames and smoking materials before refueling. Use a safety can.

**SAFETY CHAIN**

"PATENT #4180281"  
CROSS CHAIN UNDER TOW POLE WITH 4" - 5" VERTICAL SLACK  
LATCH CHAIN AT DESIRED LENGTH

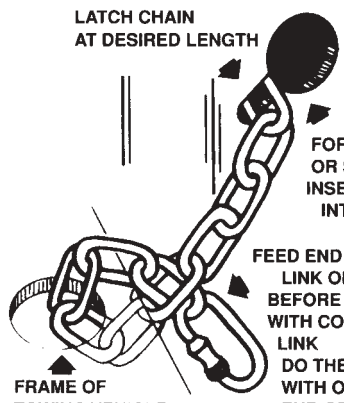

FOR EXCESS OR STORAGE, INSERT CHAIN INTO HOLE

FEED END THROUGH LINK OF CHAIN BEFORE SECURING WITH CONNECTING LINK  
DO THE SAME WITH OPPOSITE END OF CHAIN

FRAME OF TOWING VEHICLE

**CAUTION**  
READ OPERATING INSTRUCTIONS BEFORE RUNNING MIXER

55121



# Part Numbers

## Decal Identification

Item	Part No.	Description	Qty.
1^	55388	Kit Decals 655PM, 755PM, 855PM <i>Includes:</i>	1
2	55010	Decal Warning Shut Off	1
3	55011	Decal Warning Cover	1
4	55127	Decal Warning Stop Engine	1
5	55128	Decal Danger Gasoline	1
6	55156	Decal Notice Missing Decals	1
7	55046	Decal Safety Instructions	1
8^	55402	Kit Decals Std Features, Grease, Safety <i>Includes:</i>	1
9	55121	Decal Caution Safety Chain	1
10^	55119^	Decal Stone Features 7x9	1
11^	55007^	Decal Grease Weekly Blue	1
12^	55417^	Decal Engine Idle	1

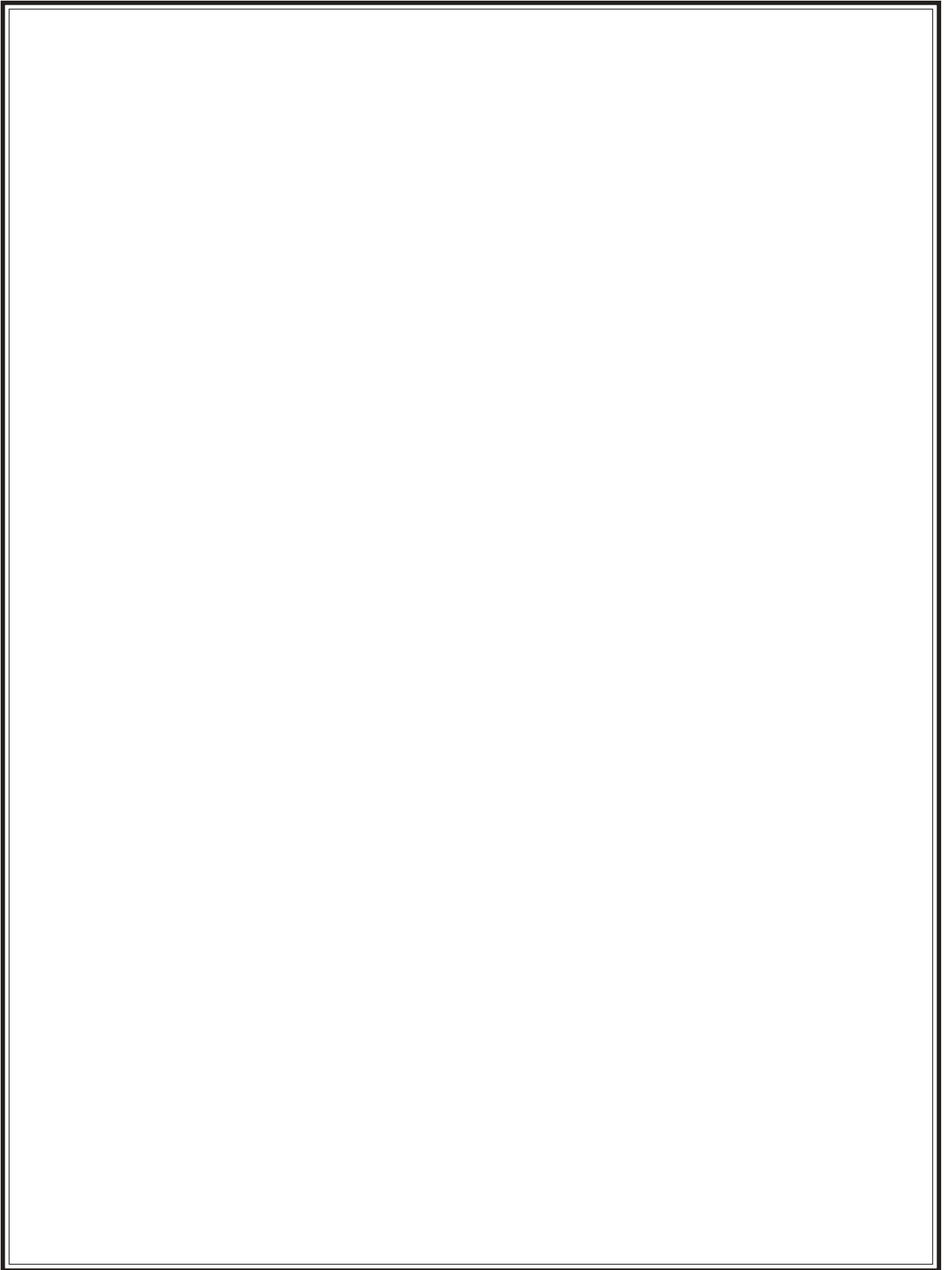

**CALIFORNIA PROPOSITION 65 WARNING: Engine exhaust from this product contains chemicals known to the State of California to cause cancer, birth defects, or other reproductive harm.**



*Bred Tough. Born to Work.  
The Way It Ought To Be.*

Stone Construction Equipment, Inc.  
P.O. Box 150, Honeoye, New York 14471  
Phone: (800) 888-9926  
Fax: 716-229-2363  
e-mail: [sceny@mcimail.com](mailto:sceny@mcimail.com)  
www: [stone-equip.com](http://stone-equip.com)

A 100% employee-owned American manufacturer

© 1987 Stone Construction Equipment, Inc.  
Printed in U.S.A.