

Broce Broom

PARTS MANUAL



MODEL
MK-1



Serial Numbers
500002 thru 500011

Revision Date: 11/04/2004

THE  LEADER

**Discount
Equipment**

www.discount-equipment.com

PARTS FINDER

**Search Website
by Part Number**



**Search Manual
Library For Parts
Manual & Lookup Part
Numbers – Purchase
or Request Quote**

**Can't Find Part or
Manual? Request Help
by Manufacturer,
Model & Description**

Discount-Equipment.com is your online resource for quality parts & equipment.

Florida: **561-964-4949** Outside Florida TOLL FREE: **877-690-3101**

Need parts?

Click on this link: <http://www.discount-equipment.com/category/5443-parts/> and choose one of the options to help get the right parts and equipment you are looking for. Please have the machine model and serial number available in order to help us get you the correct parts. If you don't find the part on the website or on one of the online manuals, please fill out the request form and one of our experienced staff members will get back to you with a quote for the right part that your machine needs.

We sell worldwide for the brands: Genie, Terex, JLG, MultiQuip, Mikasa, Essick, Whiteman, Mayco, Toro Stone, Diamond Products, Generac Magnum, Airman, Haulotte, Barreto, Power Blanket, Nifty Lift, Atlas Copco, Chicago Pneumatic, Allmand, Miller Curber, Skyjack, Lull, Skytrak, Tsurumi, Husquvarna Target, Stow, Wacker, Sakai, Mi-T-M, Sullair, Basic, Dynapac, MBW, Weber, Bartell, Bennar Newman, Haulotte, Ditch Runner, Menegotti, Morrison, Contec, Buddy, Crown, Edco, Wyco, Bomag, Laymor, EZ Trench, Bil-Jax, F.S. Curtis, Gehl Pavers, Heli, Honda, ICS/PowerGrit, IHI, Partner, Imer, Clipper, MMD, Koshin, Rice, CH&E, General Equipment, Amida, Coleman, NAC, Gradall, Square Shooter, Kent, Stanley, Tamco, Toku, Hatz, Kohler, Robin, Wisconsin, Northrock, Oztec, Toker TK, Rol-Air, APT, Wylie, Ingersoll Rand / Doosan, Innovatech, Con X, Ammann, Mecalac, Makinex, Smith Surface Prep, Small Line, Wanco, Yanmar

TABLE OF CONTENTS

Belt Conveyor Pages	1-8
Top End View	1
Top Left Side View	1
Middle Left Side View	2
Lower Left Side View	2
Bottom Left Side View	3
Top Right Side View	4
Belt Cleaner View	4
Bottom Right Side View	5
Lift Cylinder Mount View	6
Lift Cross Tube View	7
Leveling Cylinder View	7
Pivot Cylinder View	8
 Slat Conveyor Pages.....	 9-11
Left Side View.....	9
Right Side View	10
Drive Side View	11
 Screw Conveyor Pages.....	 12-14
Left Side View.....	12
Center View	13
Outer Left Side View.....	14
 Frame Attached Components	 15-38
Left Side – Below Cab View	15
Right Side – Broom Core View	16
Core Motor View	17
Middle Left Side View	18
Fuel/Hydraulic Tank View	19
Rear Left Side View	20
Rear Drive View.....	21
Pressure Manifold View	22
Steering Pump View	23
Steering Cylinder View	24
Bolster Assembly	25
Brake Control Assembly	26
Front Axle Assembly.....	27-28
Front Brake Assembly	29-30
M-46 Hydrostat View	31
M-45 Piston Pump View	32
PVG Valve View	33
Hydraulic Tank View.....	34

TABLE OF CONTENTS (Cont.)

Frame Attached Components (Cont.)	15-40
Case Drain Manifold View	35
Core Lift Cylinder & Lift Lock Solenoid	36
Gear Box Assembly	37-38
Water Spray System.....	39-40
Cab Components and Electrical	41-60
Cab Assembly	41-42
TM Cab Front View.....	43
Seat & Suspension Components.....	44
Broom/Conveyor Control Box.....	45
Transmission Control Box	46
Hydrostatic Control Assembly.....	47
Dash/Steering Assembly	48
Gauges & Senders	49-50
Windshield Wipers & Washer	51-51
Misc. Switchers, Fuses, Etc.....	53-54
Lights & Horns.....	55-56
Heater/Defroster System.....	57-58
Air conditioner System.....	59-60
Engines & Related Parts	62-66
3054B Cat Engine and Related Parts.....	62-63
3054C Cat Engine and Related Parts.....	64-65
Hydraulic Diagrams	67-69
Parts Index	72-74
Notes	75

BELT CONVEYOR - TOP END VIEW

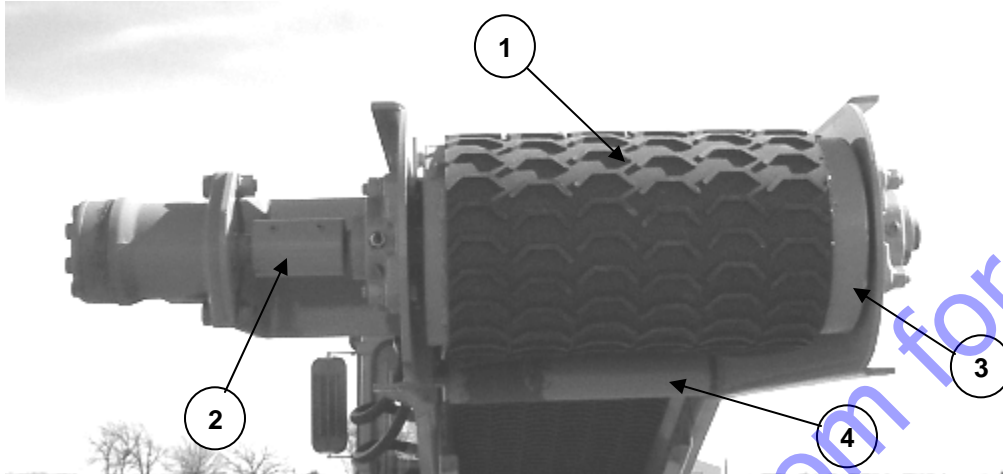

ITEM	PART NUMBER	DESCRIPTION	QUANTITY
1	320617	Conveyor Belting, 12" x 33' 4"	1
2	205076	Conveyor Drive Coupling	1
3	320601	Head Pulley w/ Shaft	1
4	320622	Return Rollers	4

BELT CONVEYOR - TOP LEFT SIDE

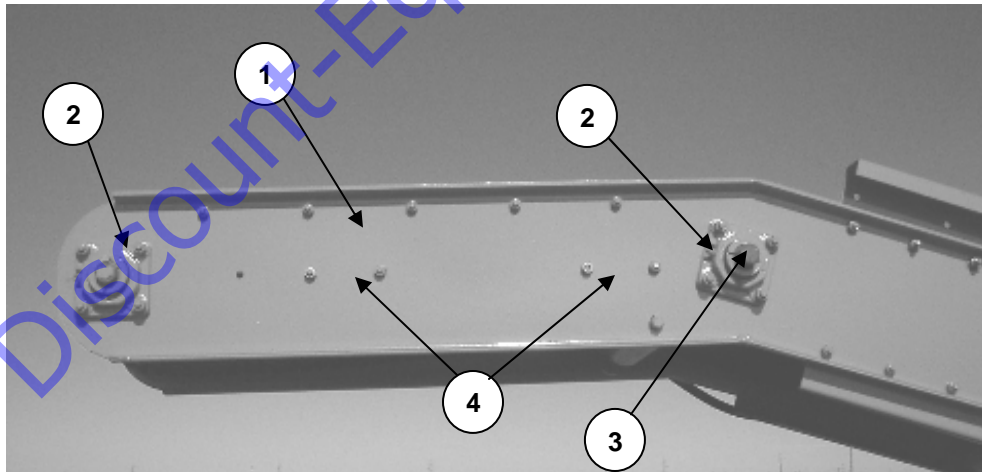

ITEM	PART NUMBER	DESCRIPTION	QUANTITY
1	205084	LH Upper Side Frame, 17.5°	1
2	320600	Head and Center Conveyor Bearings	4
3	320602	Center Wing Pulley w/ Shaft	1
4	205082	Conveyor Cross Member	2

BELT CONVEYOR – MIDDLE LEFT SIDE

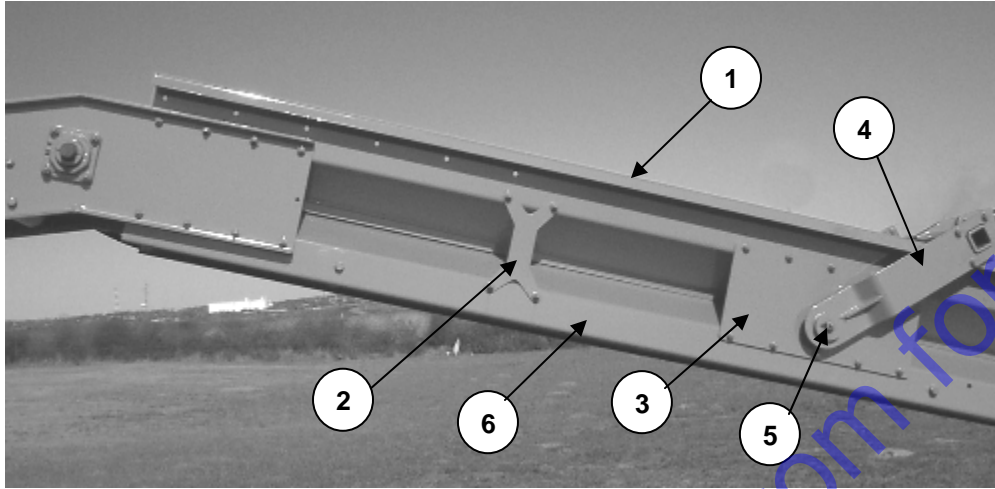

ITEM	PART NUMBER	DESCRIPTION	QUANTITY
1	205061	Upper Side Sheet	2
2	205060	Side Gusset	4
3	855066	Center Side Plate w/ bushing	2
4	855067	Lift Side Bracket	2
5	205086	1/2" x 1" Cap Screw w/ Zerk, LH & RH	2
6	205063	Return Sheet	1

BELT CONVEYOR – LOWER LEFT SIDE

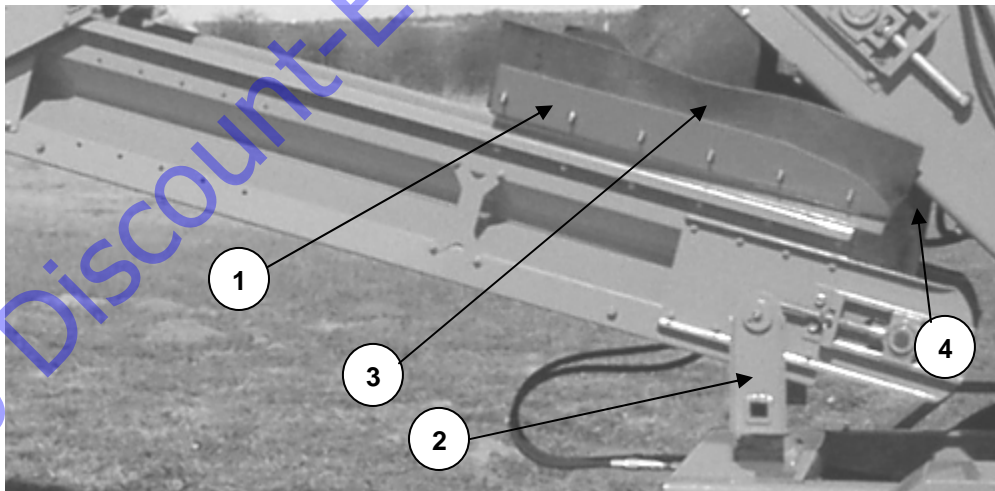

ITEM	PART NUMBER	DESCRIPTION	QUANTITY
1	205062	Lower Deflector, LH	1
2	855050	Belt Conveyor Cross Tube w/ Left Side Support Bracket	1
3	205229	Belt Conveyor Wing Rubber	2
4	205230	Lower Belt Conveyor Rubber	1

BELT CONVEYOR – BOTTOM LEFT SIDE

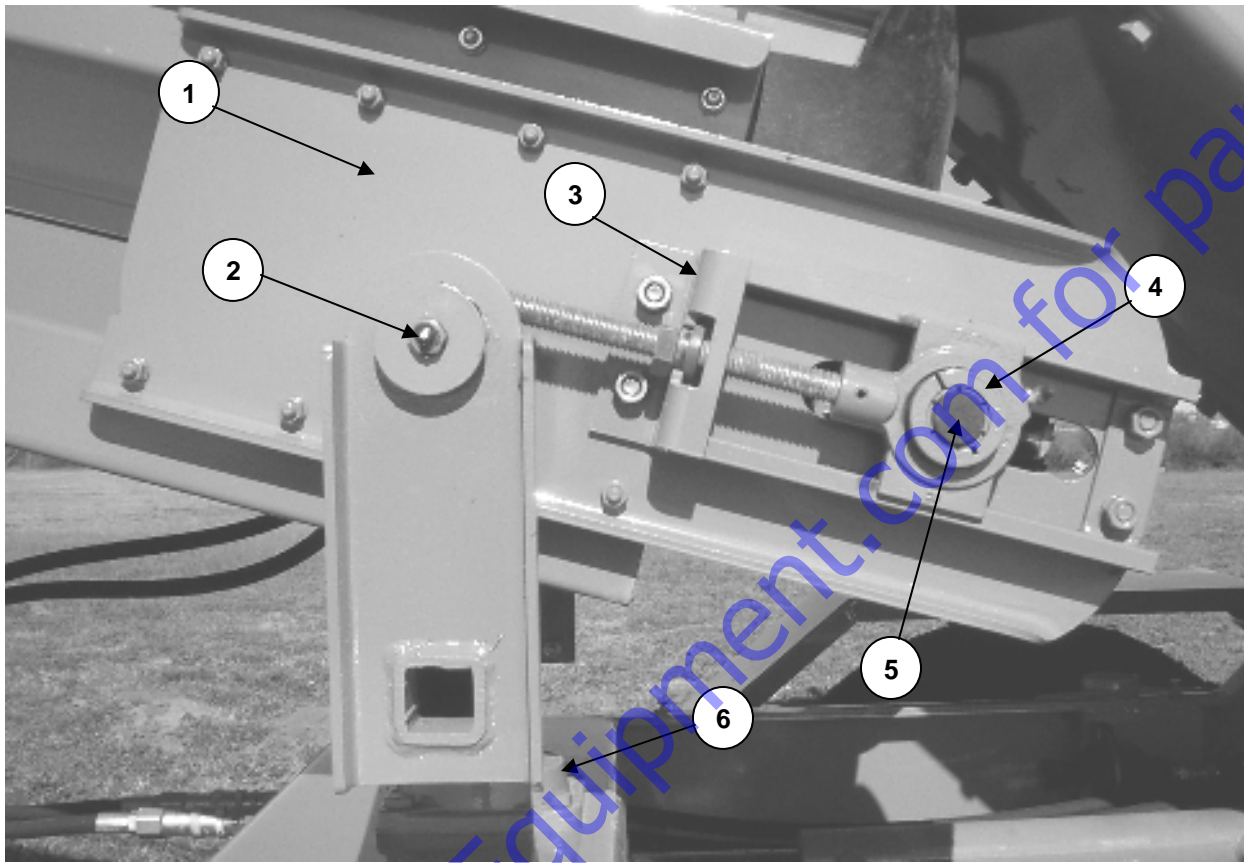

ITEM	PART NUMBER	DESCRIPTION	QUANTITY
1	855077	Take-Up Side Plate – Lower, LH	1
2	205086	1/2" x 1" Cap Screw w/ Zerk, LH & RH	2
3	320604	Lower Take-up Frame	2
4	320605	Lower Take-up Bearing	2
5	320603	Wing Pulley w/ Shaft	1
6	320611	Swing Bearing, Top and Bottom	2

BELT CONVEYOR - TOP RIGHT SIDE

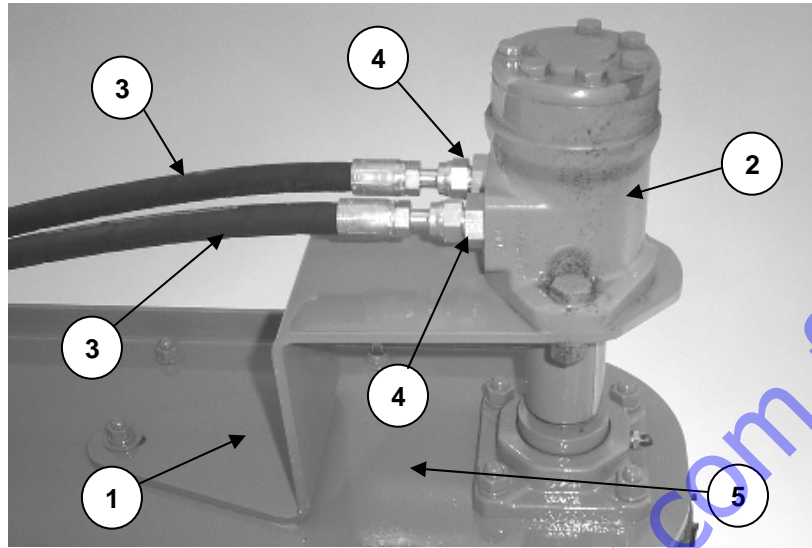

ITEM	PART NUMBER	DESCRIPTION	QUANTITY
1	205078	Conveyor Hydraulic Motor Mount	1
2	325008	Belt Conveyor Motor	1
3	N/A	Hydraulic Hose Assembly, 52" – 1AA8MR6 & 1AA6FR6	2
4	N/A	Hydraulic Adapter Fitting – FF1852T0610S	2
5	205083	RH Upper Side Frame, 17.5°	1

BELT CONVEYOR – BELT CLEANER

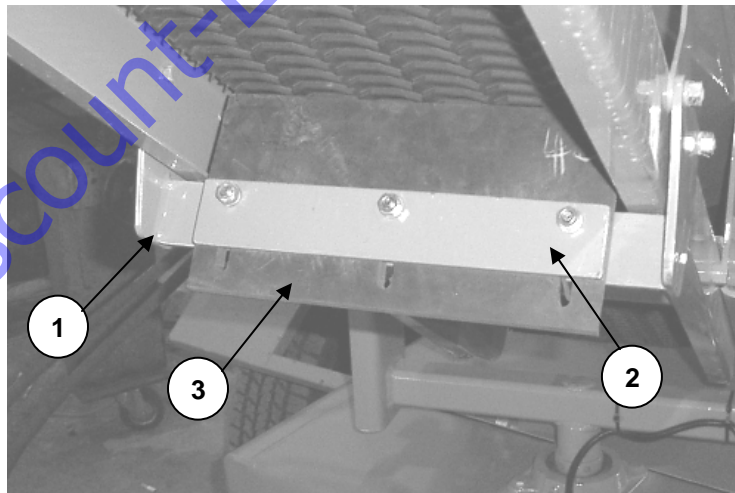

ITEM	PART NUMBER	DESCRIPTION	QUANTITY
1	855233	Belt Conveyor Cross Member	1
2	205235	Belt Conveyor Cleaner Blade Retainer	1
3	205232	Belt Conveyor Cleaner Blade	1

BELT CONVEYOR – BOTTOM RIGHT SIDE

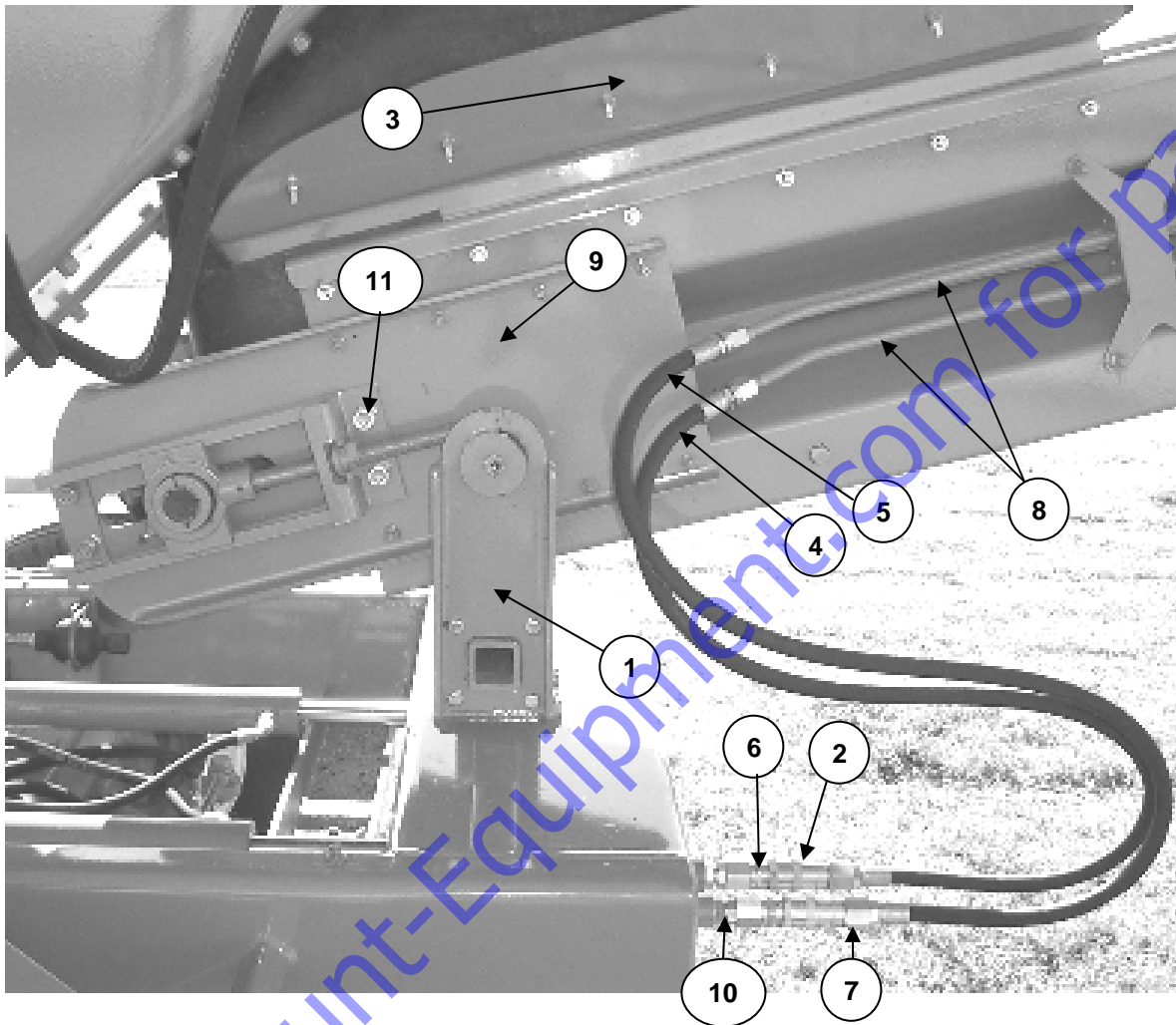

ITEM	PART NUMBER	DESCRIPTION	QUANTITY
1	855052	Right Side Support Bracket w/ Bushing	1
2	N/A	Quick Coupler – Female FD49-1005-08-06	2
3	205064	Lower Deflector, RH	1
4	N/A	Hydraulic Hose Assembly, 46" – 1AA8MB6 & 1AA8MR6	1
5	N/A	Hydraulic Hose Assembly, 44" – 1AA8MB6 & 1AA8MR6	1
6	N/A	Quick Coupler – Male FD49-1004-08-06	2
7	N/A	Hydraulic Adapter, 3474-08-08	2
8	N/A	Steel Hydraulic Line – 114"	2
9	855088	Take Up Side Plate - Lower, RH	1
10	N/A	Hydraulic Fitting	2
11	320604	Rear Belt Conveyor Cross Member	1

BELT CONVEYOR – LIFT CYLINDER MOUNT

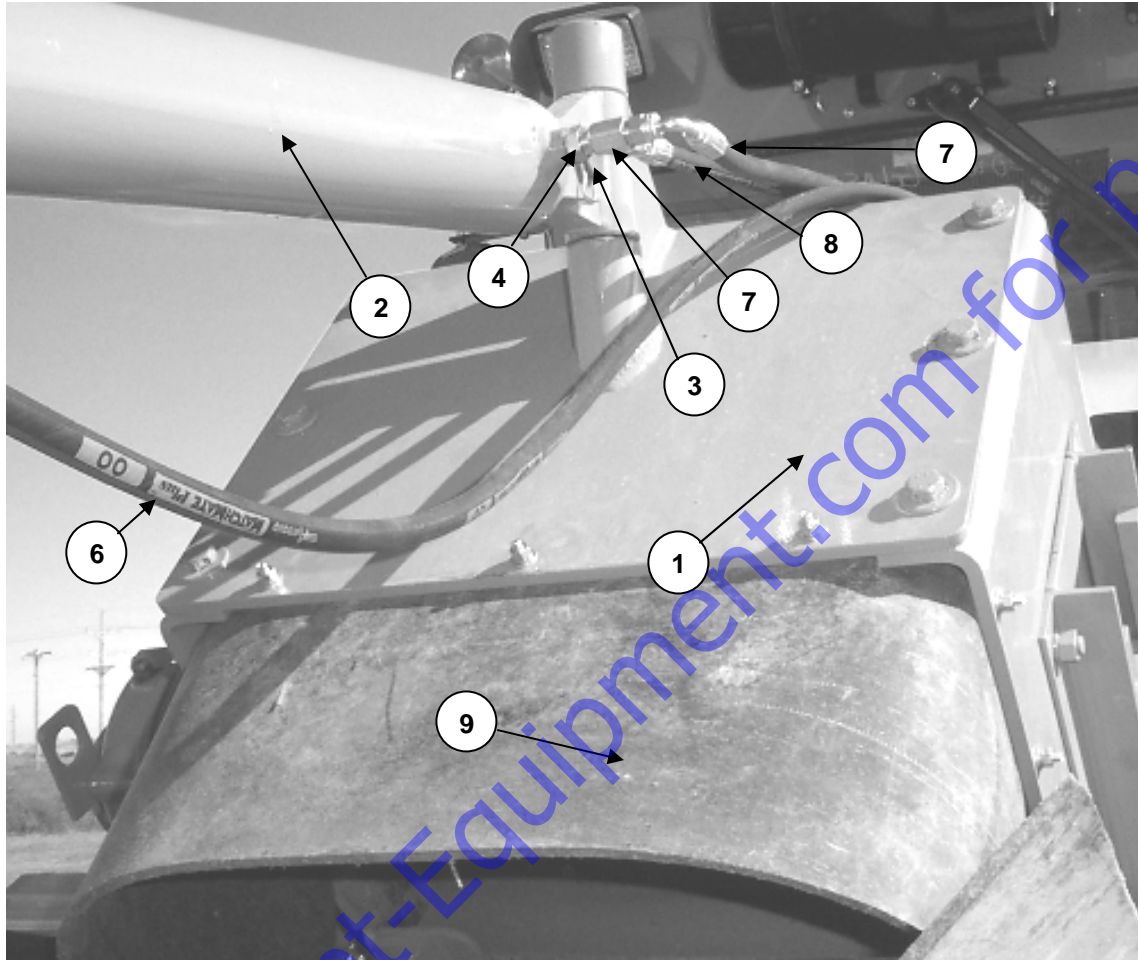

ITEM	PART NUMBER	DESCRIPTION	QUANTITY
1	855030	Bottom Lift Support w/ Bushings & Shaft	1
2	325012	Belt Conveyor Lift Cylinder, 3" x 29 5/8"	1
3	205079	Cylinder Pin	1
4	N/A	Hydraulic Fitting, FF1868T0406S	2
5	N/A	Hydraulic Hose Assembly, 115" – 1AA4FR4 & 1AA6FRB4	1
6	N/A	Hydraulic Hose Assembly, 84" – 1AA4FR4 (2)	1
7	N/A	Hydraulic Adapter Tee, FF1865T0406S	1
8	N/A	Hydraulic Hose Assembly, 52" – 1AA4FRB4 (2)	1
9	205231	Slat Conveyor Discharge Deflector (Rubber)	1

BELT CONVEYOR – LIFT CROSS TUBE

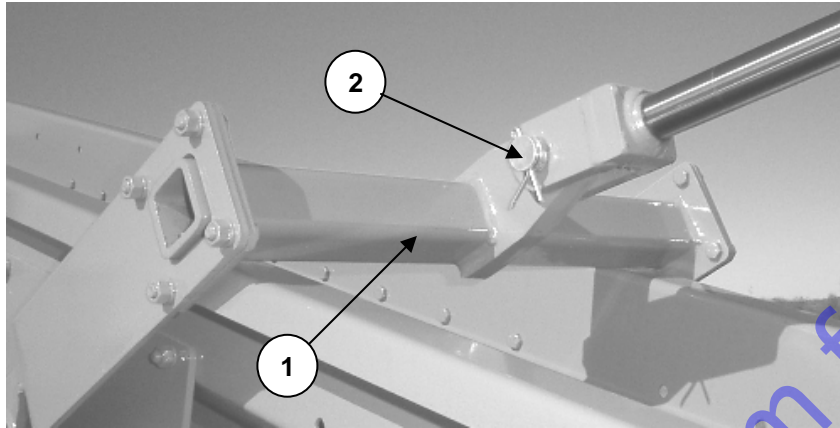

ITEM	PART NUMBER	DESCRIPTION	QUANTITY
1	855068	Belt Conveyor Lift Cylinder Cross Tube	1
2	205079	Cylinder Pin	1

LEVELING CYLINDER VIEW

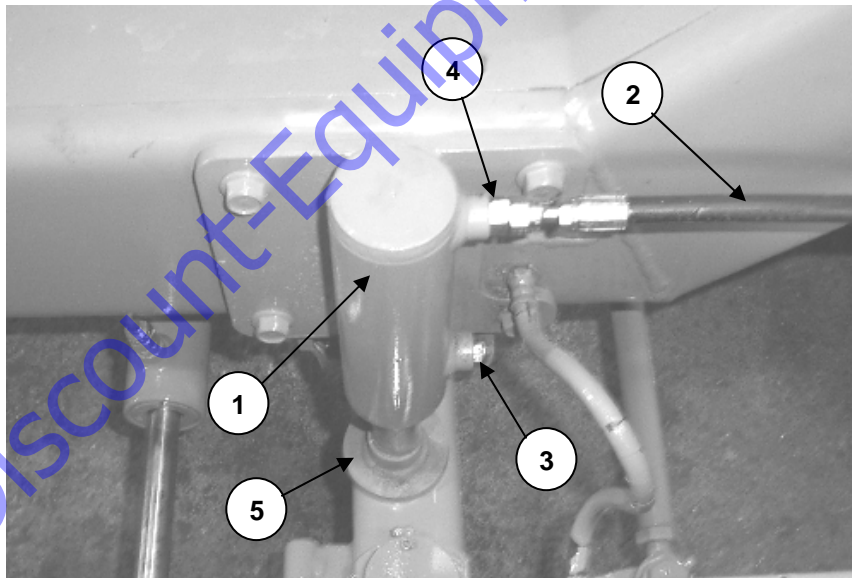

ITEM	PART NUMBER	DESCRIPTION	QUANTITY
1	855089	Leveling Cylinder Assembly w/ Mount Plate, LH	1
	855090	Leveling Cylinder Assembly w/ Mount Plate, RH	1
2	N/A	Hydraulic Hose Assembly, 21" – 1AA4FR4 & 1AA6FR4	2
3	N/A	Vent, BV-SAE-6	2
4	N/A	Hydraulic Fitting, FF1852T0406S	2
5	855092	Leveling Cylinder Foot	2

BELT CONVEYOR – PIVOT CYLINDER VIEW

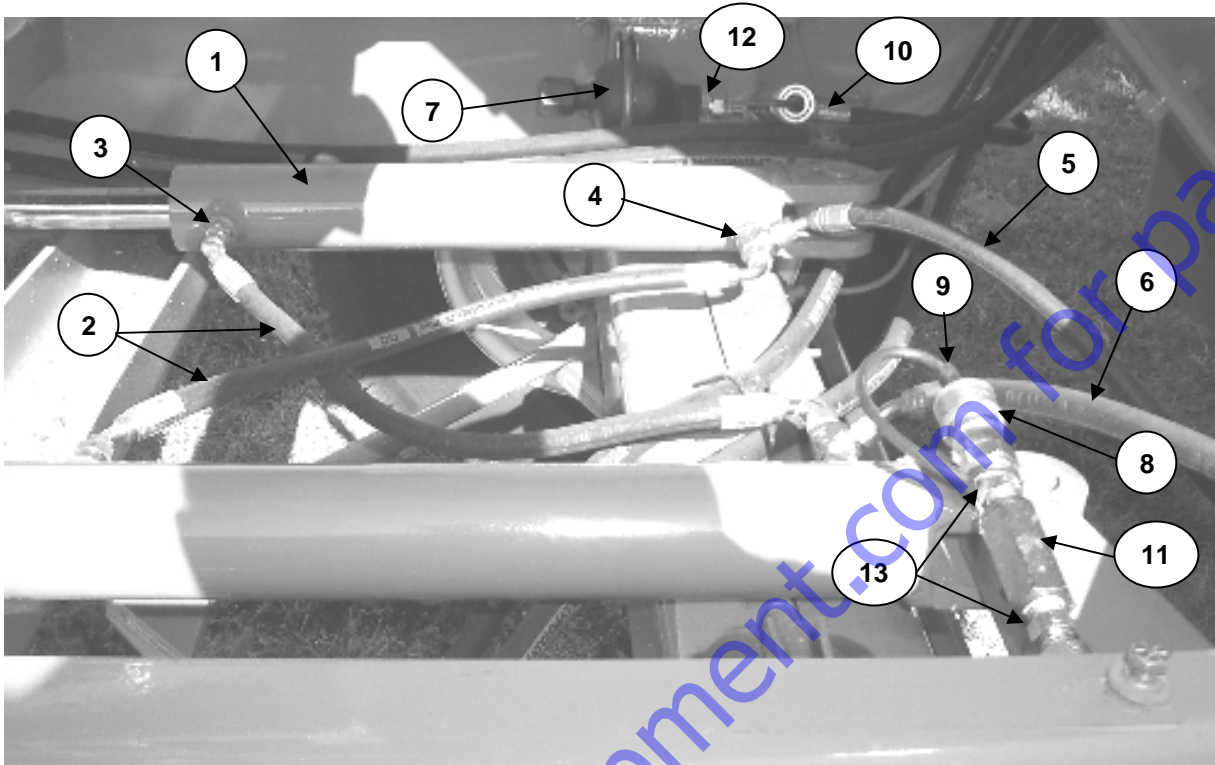

ITEM	PART NUMBER	DESCRIPTION	QUANTITY
1	325013	Swing Cylinder, 2" x 12"	2
2	N/A	Hydraulic Hose Assembly, 16" – 1AA4FRA4 & 1AA4FRB4	2
3	N/A	Hydraulic Fitting, FF1852T0406S	2
4	N/A	Hydraulic Fitting, FF1865T0406S	2
5	N/A	Hydraulic Hose Assembly, 92" – 1AA4FRA4 & 1AA6FRC4	1
6	N/A	Hydraulic Hose Assembly, 80" – 1AA4FRA4 & 1AA6FRB4	1
7	N/A	Accumulator	2
8	N/A	Female Quick Coupler, 5601-4-4S	2
9	N/A	Plug, 5659-4	2
10	N/A	CAT Tee, 8T2352	2
11	N/A	Check Valve, C20S-1/4"	2
12	N/A	Hydraulic Adapter, FF1852T0606S	2
13	N/A	Nipples, 2083-4-4S	4

SLAT CONVEYOR – LEFT SIDE VIEW

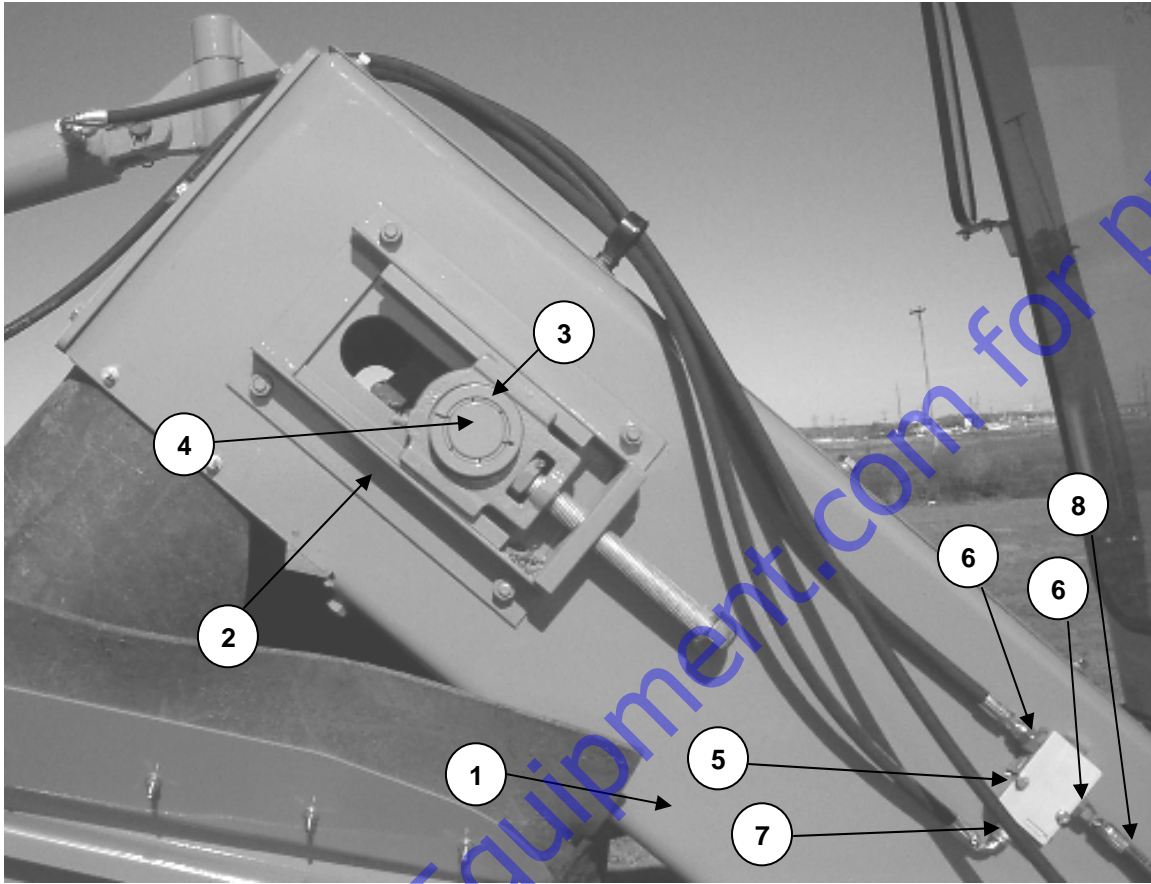

ITEM	PART NUMBER	DESCRIPTION	QUANTITY
1	205020	Slat Conveyor Side, LH	1
2	320606	Slat Conveyor Take-up Frame	2
3	320607	Slat Conveyor Take-up Bearing	2
4	205025	Slat Conveyor Head Shaft	1
5	325011	Load Holding Valve	1
6	N/A	Hydraulic Adapter, FF1852T0408S	2
7	N/A	Hydraulic Adapter, FF1852T0404S	1
8	N/A	Hydraulic Hose Assembly, 61" – 1AA4FR4 & 1AA6FRC4	1

SLAT CONVEYOR – RIGHT SIDE VIEW

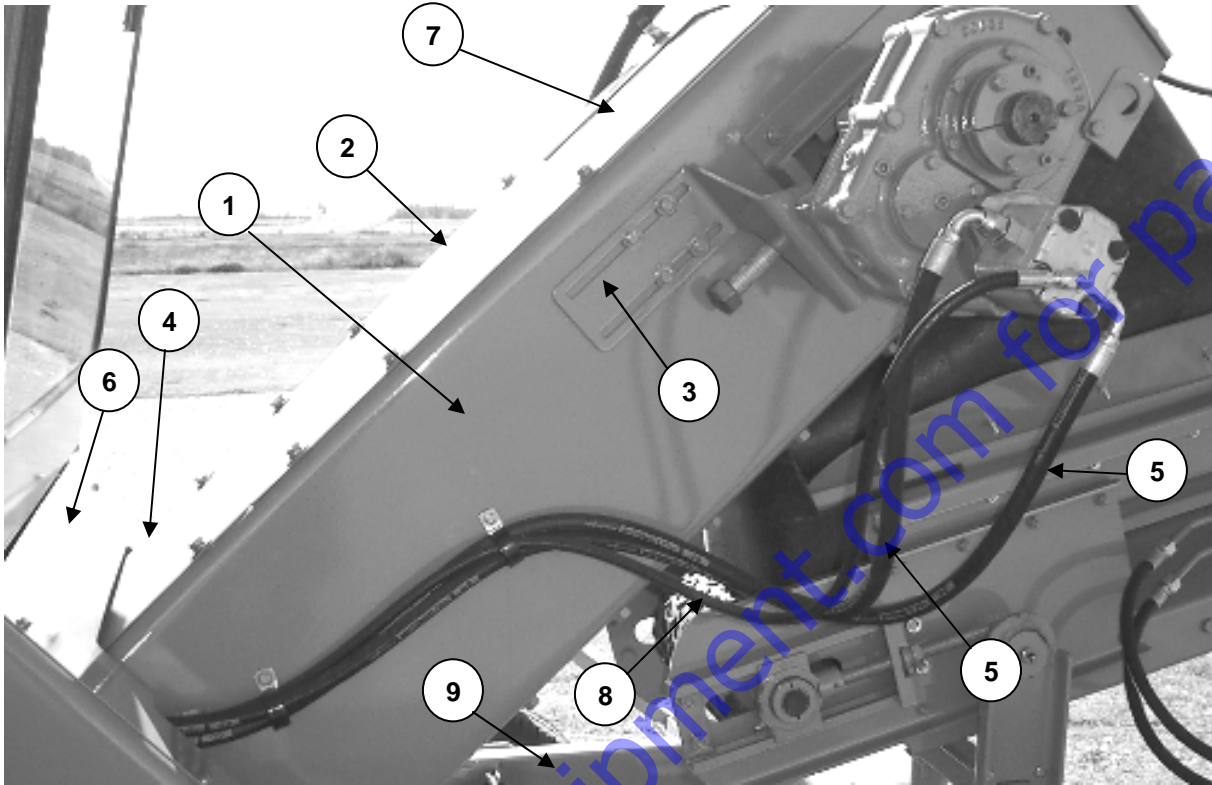

ITEM	PART NUMBER	DESCRIPTION	QUANTITY
1	205019	Slat Conveyor Side, RH	1
2	205031	Slat Conveyor Top Cover, Upper	1
3	205039	Speed Reducer Bracket	1
4	205032	Slat Conveyor Top Cover, Lower	1
5	N/A	Hydraulic Hose Assembly, 121" – 1AA8FRB8 (2)	2
6	205098	Front Frame Cover, Top	1
7	205040	Slat Conveyor Window	1
8	N/A	Hydraulic Hose Assembly, 190" – 1AA4FR4 & 1AA6FRC4	1
9	205099	Front Frame Cover, Bottom	1

SLAT CONVEYOR – DRIVE SIDE VIEW

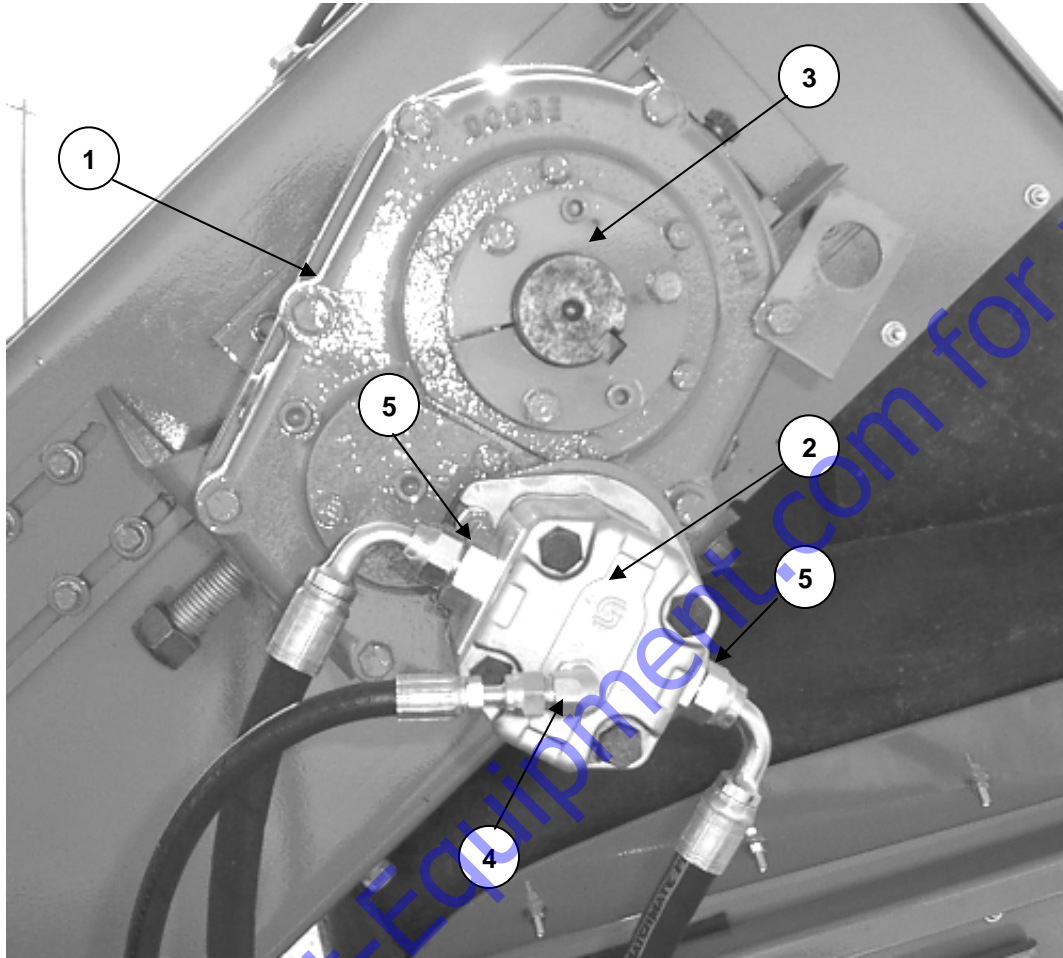

ITEM	PART NUMBER	DESCRIPTION	QUANTITY
1	320615	Dodge Speed Reducer	1
2	325007	Slat Conveyor Motor	1
3	320616	Speed Reducer Shaft Adapters, Set of 2	1
4	N/A	Hydraulic Adapter, FF1868T0406S	1
5	N/A	Hydraulic Adapter, FF1852T0810S	2

SCREW CONVEYOR - LEFT SIDE VIEW

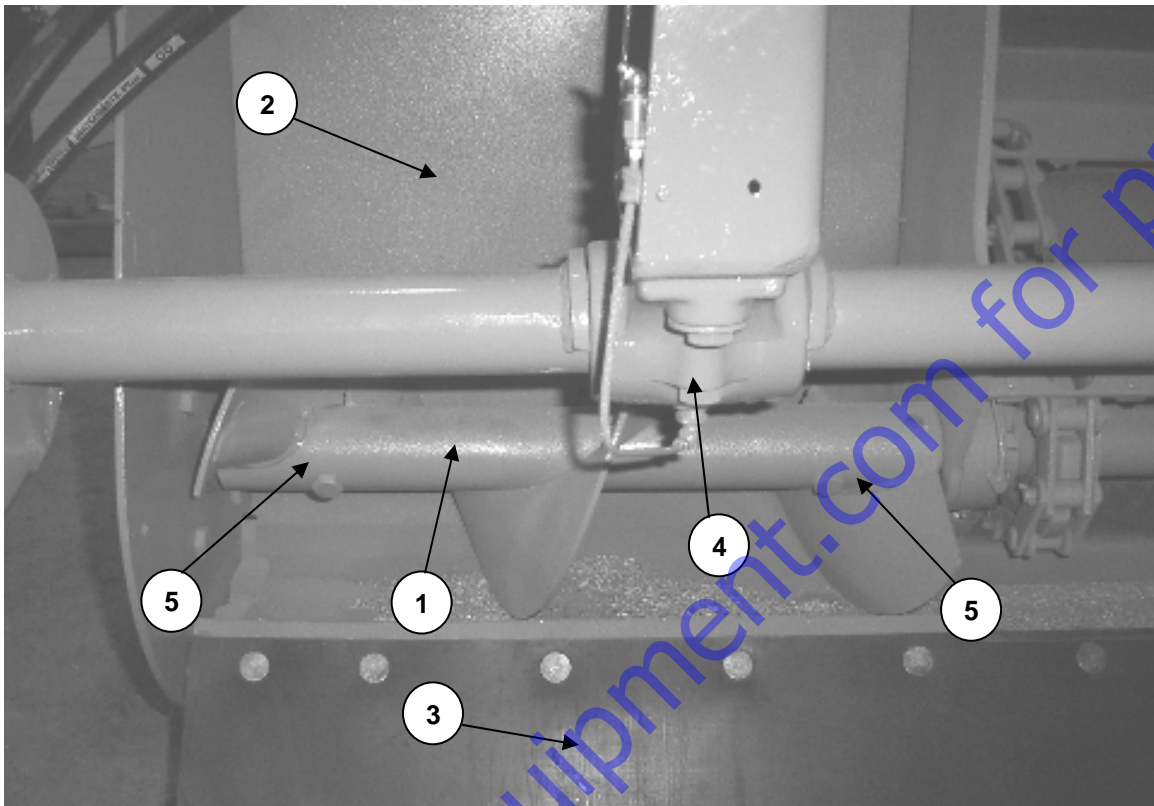

ITEM	PART NUMBER	DESCRIPTION	QUANTITY
1	320618	Screw Conveyor, 25" – RH	1
	320619	Screw Conveyor, 25" – LH (Not Shown)	1
2	855018	Screw Conveyor Box, LH	1
	855017	Screw Conveyor Box, RH (Not Shown)	1
3	205227	Rock Shield, 14" x 7'	1
4	320609	Core Frame Support Bearing, LH & RH	2
5	320625	Auger Wedge Cutout (2 LH & 2 RH)	4

SCREW CONVEYOR – CENTER VIEW

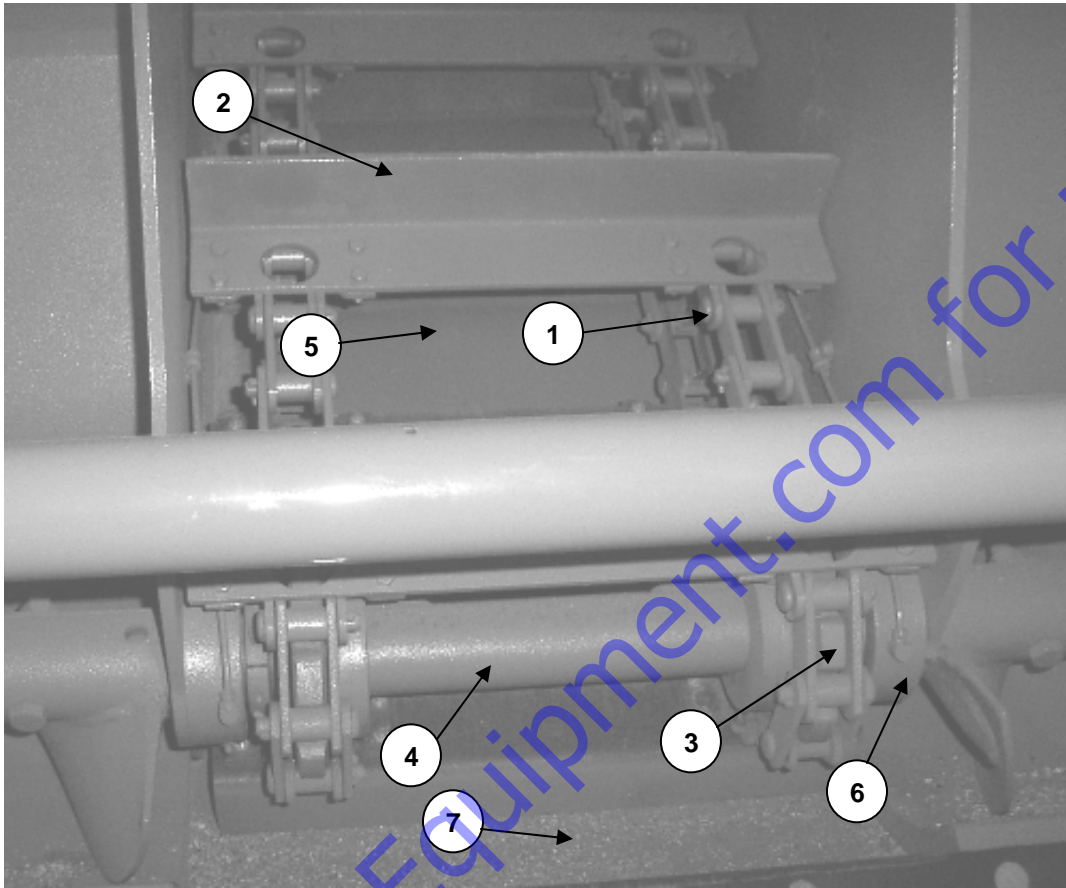

ITEM	PART NUMBER	DESCRIPTION	QUANTITY
1	320621	Slat Conveyor Chain	2
2	205029	Slat	16
3	320620	Sprockets	4
4	205024	Center Conveyor Shaft	1
5	205028	Slat Conveyor Floor	1
6	320608	Lower Slat Conveyor Bearing	2
7	855021	Slat Conveyor Floor Connector Assembly	1

SCREW CONVEYOR – LEFT OUTER VIEW

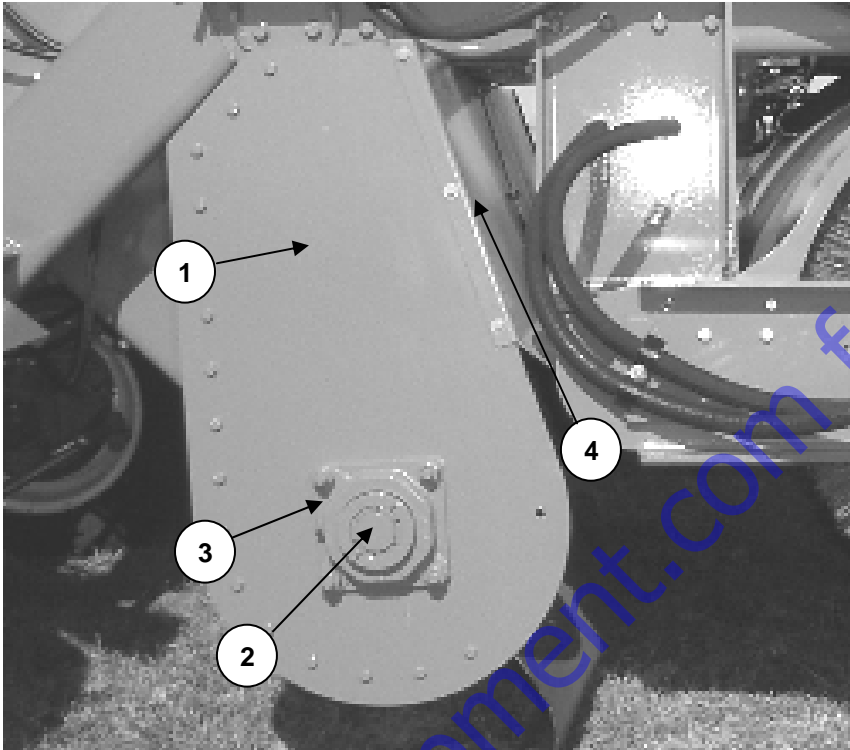

ITEM	PART NUMBER	DESCRIPTION	QUANTITY
1	205016	Auger Conveyor End Plate, LH & RH	2
2	205023	Outboard Screw Conveyor Stub Shaft, LH & RH	2
3	320613	Outboard Auger Bearings	2
4	855141	Dust Shield, LH	1
	855140	Dust Shield, RH (Not Shown)	1

LEFT SIDE VIEW – BELOW CAB

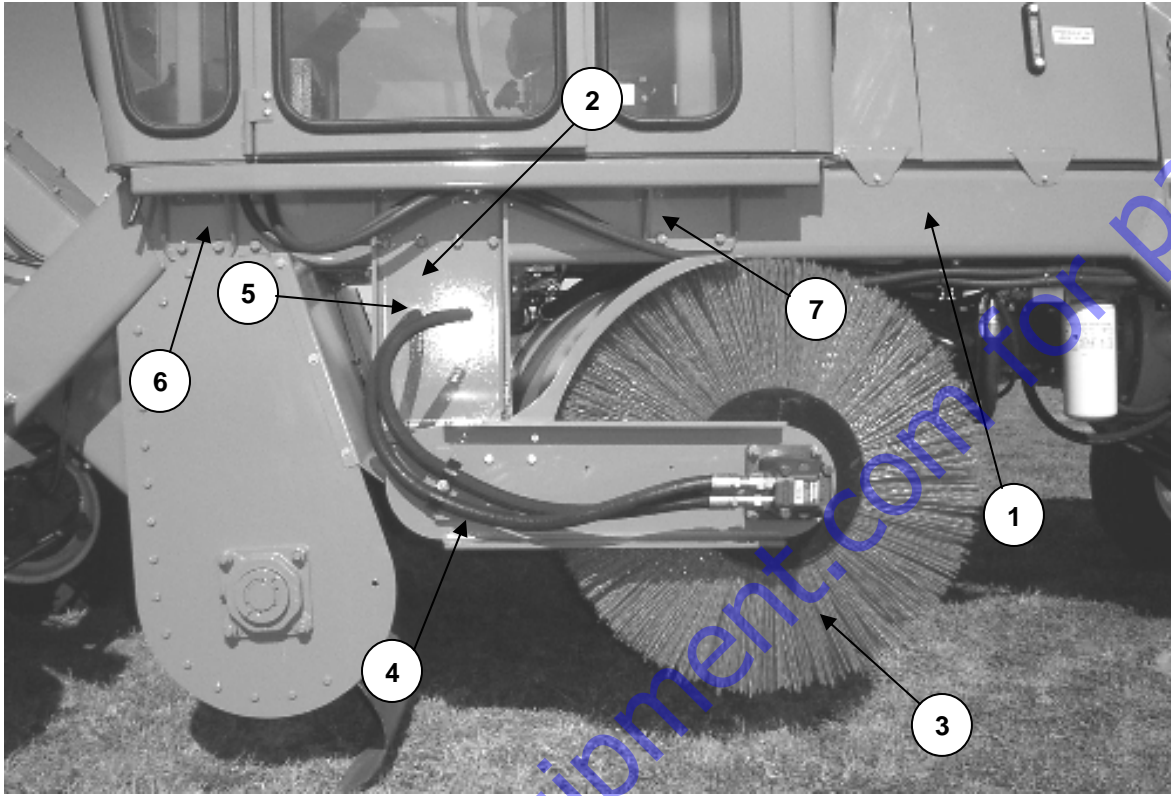

ITEM	PART NUMBER	DESCRIPTION	QUANTITY
1	855001	Frame Assembly	1
2	205000	Brush Support Bracket	2
3	RW-500	8' Set, Poly Wafers w/ Spacers	1
	RW-502	8' Set, Half Poly & Half Wire Wafers w/ Spacers	1
4	N/A	Hydraulic Hose Assembly, 46" – 1AA12FR12	2
5	N/A	Hydraulic Fitting, FF1944T1212S	2
6	205161	Front ROPS Attaching Bracket, LH	1
	205160	Front ROPS Attaching Bracket, RH	1
7	205162	Rear ROPS Attaching Bracket	2

RIGHT SIDE VIEW – BROOM CORE

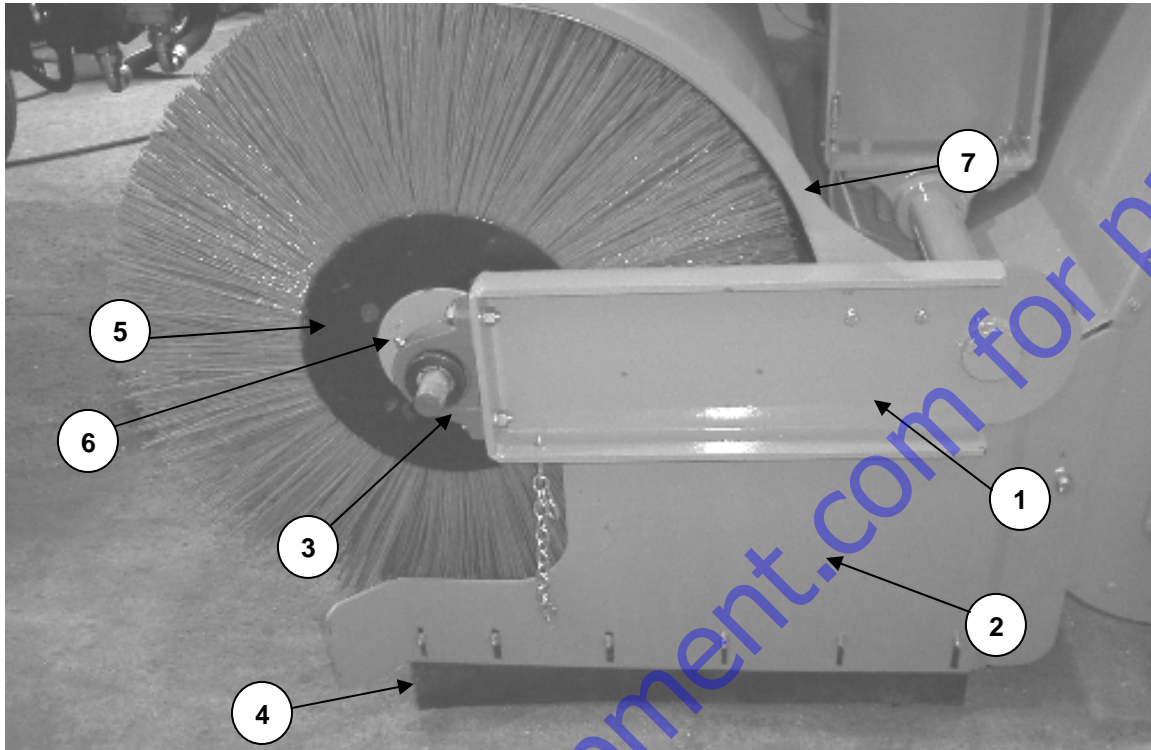

ITEM	PART NUMBER	DESCRIPTION	QUANTITY
1	855004	Core Frame Assembly	1
2	205043 205044	Brush End Gate, RH Brush End Gate, LH	1 1
3	320610	Core Support Bearing, RH	1
4	205228	Core Side Sheet Rubber	2
5	203010	End Plate	2
6	855011	Core Idle Assembly	1
7	855037	Core Cover Assembly	1

CORE MOTOR VIEW

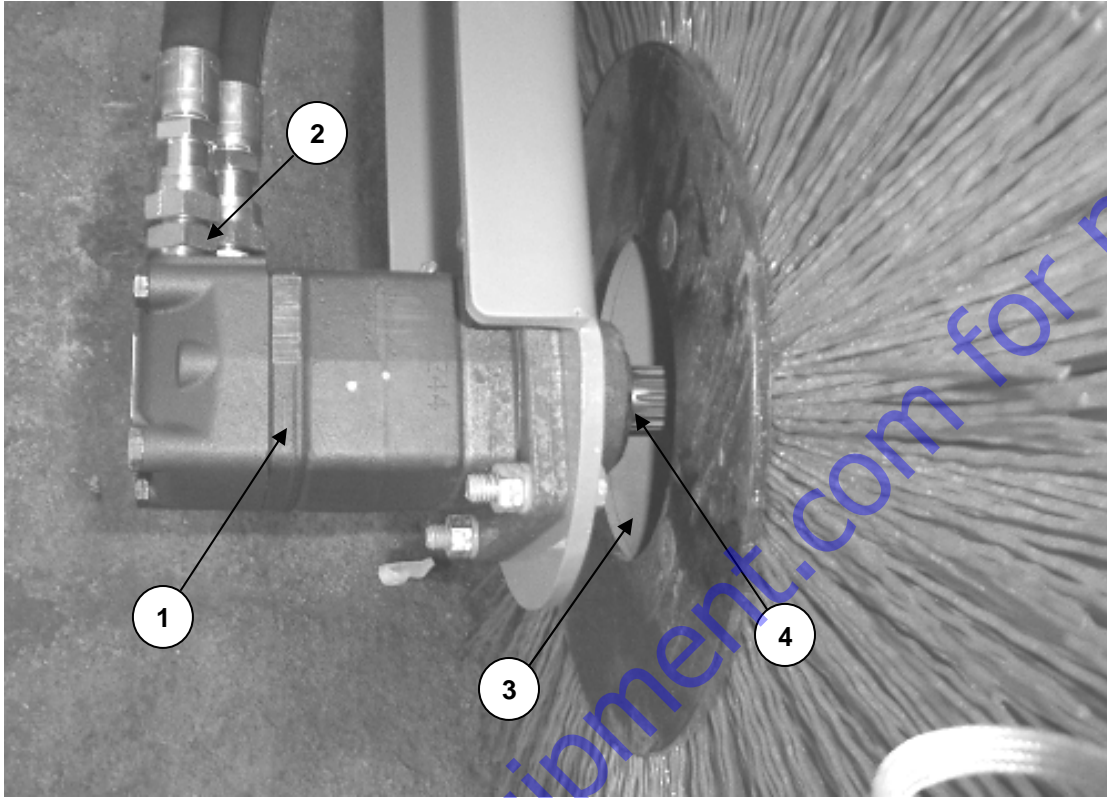

ITEM	PART NUMBER	DESCRIPTION	QUANTITY
1	325010	Core Motor OMSW 400	1
2	N/A	Hydraulic Fitting, FF1852T1210S	2
3	855005	Core Assembly	1
4	855010	Core Drive Assembly (Splined Hub)	1

MIDDLE LEFT SIDE VIEW

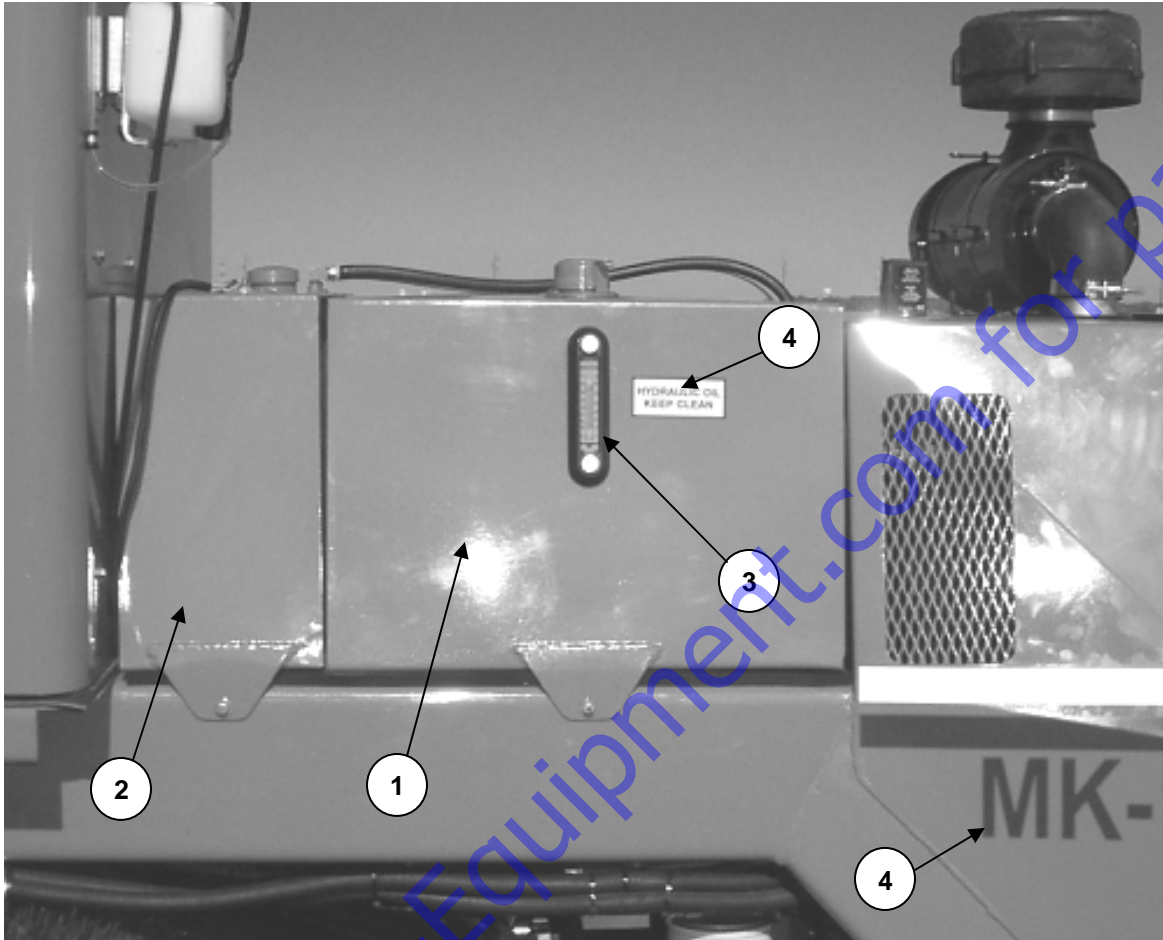

ITEM	PART NUMBER	DESCRIPTION	QUANTITY
1	855153	Hydraulic Tank Assembly	1
2	855158	Fuel Tank Assembly	1
3	305505	Sight Glass	1
4	311665	Decal Kit	1

NOTE: Decal Kit includes all exterior decals including safety stickers. Decals may be ordered separately. Request individual decals when ordering.

FUEL/HYDRAULIC TANK TOP VIEW

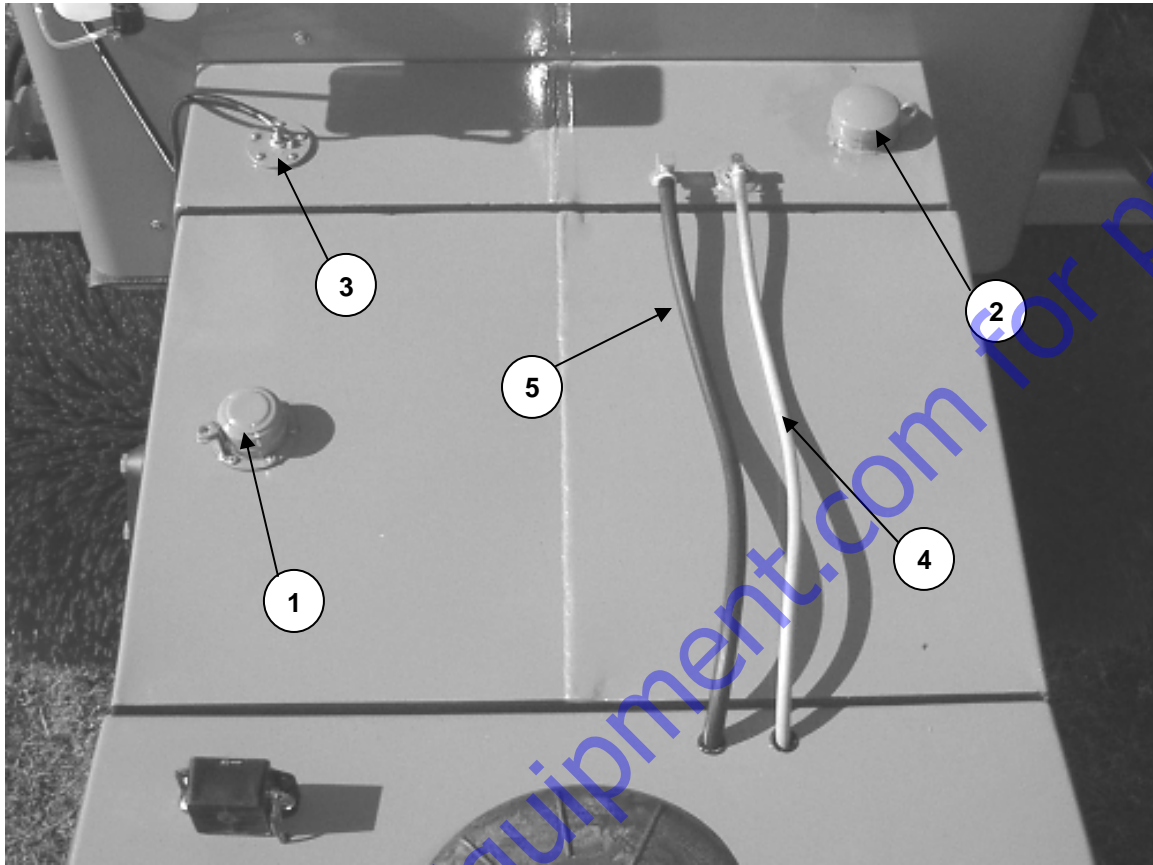

ITEM	PART NUMBER	DESCRIPTION	QUANTITY
1	T-703-BA	Hydraulic Cap	1
2	T-702-B	Fuel Cap	1
3	344175	Fuel Gauge Assembly	1
4	304172	3/8" Fuel Hose, 48"	1
5	304172	3/8" Fuel Hose, 60"	1

REAR LEFT SIDE VIEW

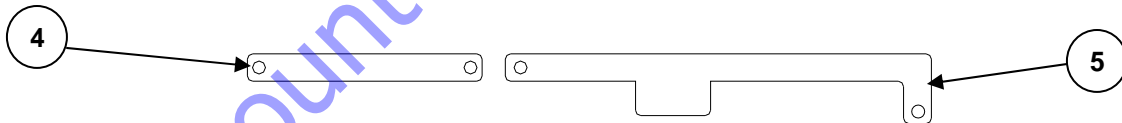
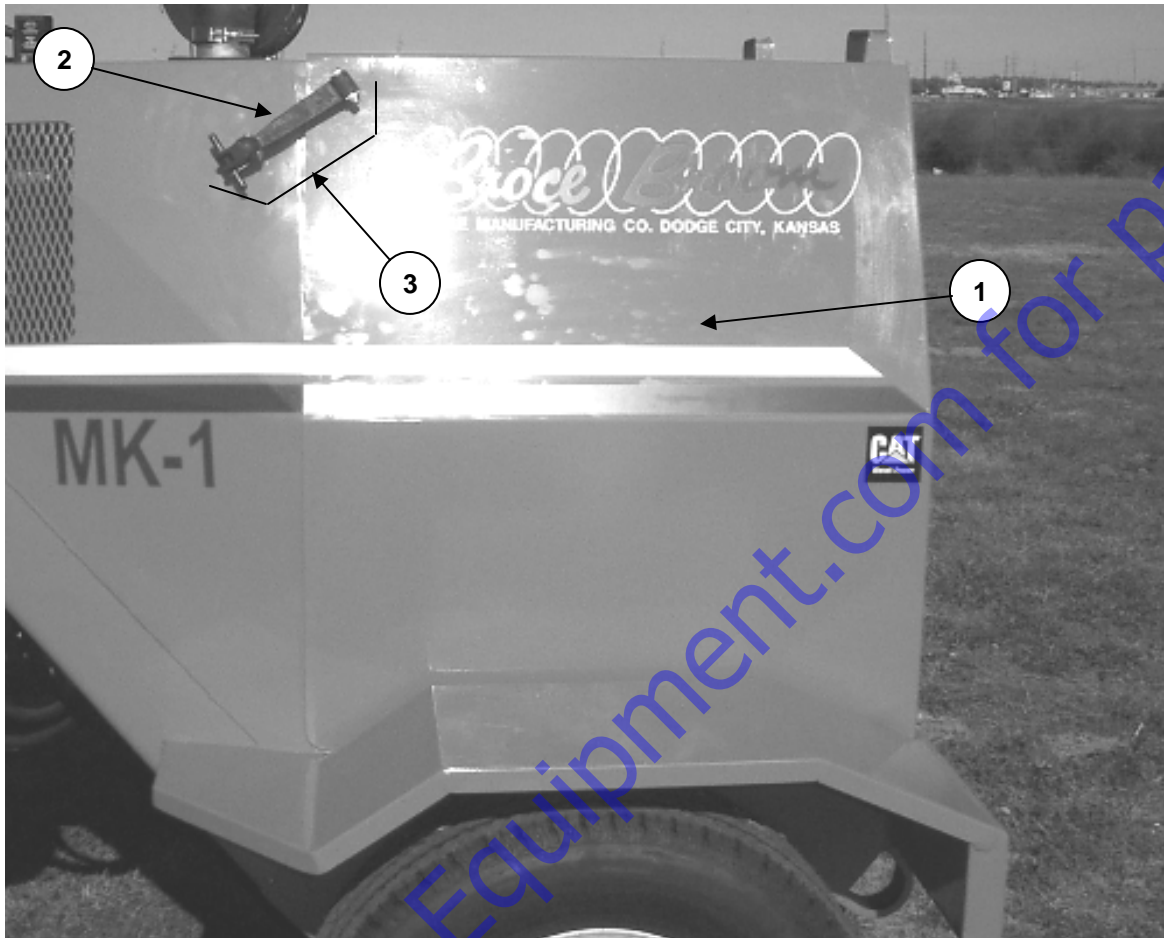

ITEM	PART NUMBER	DESCRIPTION	QUANTITY
1	855215	Hood Assembly	1
2	VF-803-R	Hood Catch (Rubber Strap Only)	2
3	VF-319-RA	Catch Assembly (Complete)	2
4	205221	Front Hood Retract Support Linkage	2
5	203274	Rear Hood Retract Support Linkage	2
NS	VF-317-B	Hinge, Set of 2	1

REAR DRIVE VIEW

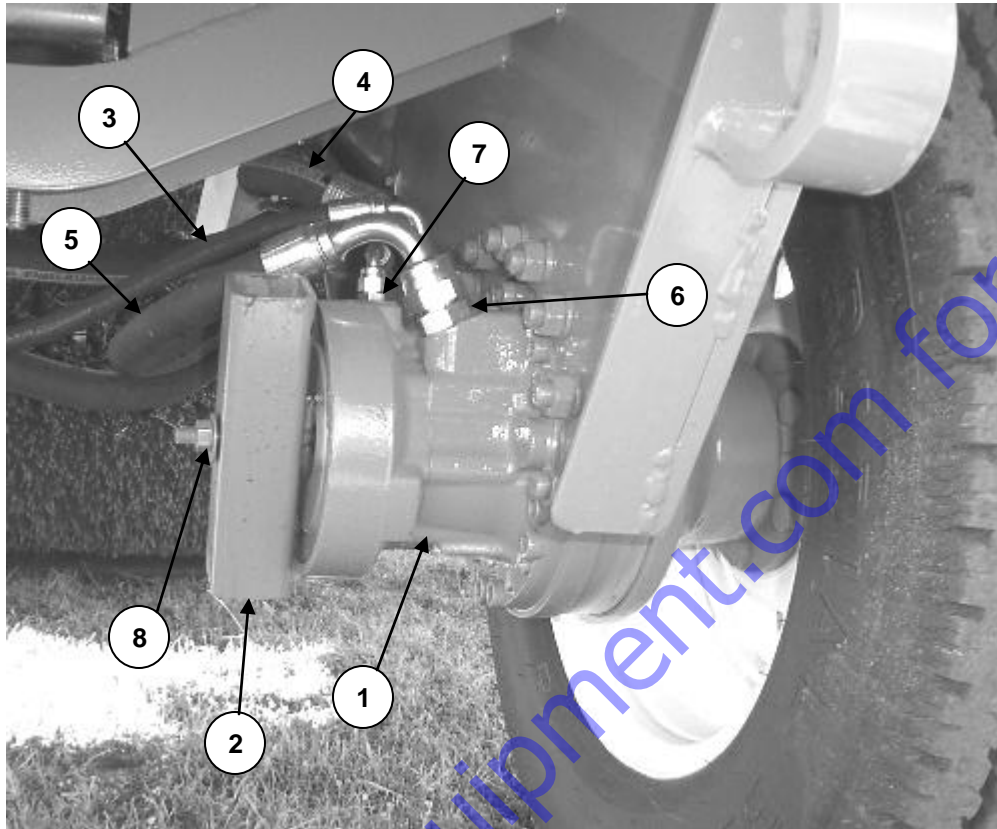

ITEM	PART NUMBER	DESCRIPTION	QUANTITY
1	325002 325001	Poclain 34ci Motor with parking brake, LH and RH Poclain 34ci Motor, no brake S/N 500001-500050, LH only	2 1
2	K00024	Brake Release, 2" x 2" Square Tube, RH Only	1
3	N/A	Hydraulic Hose Assy., 68" – 1AA6FRA6 & 1AA6FRC6, RH Hydraulic Hose Assy., 25" – 1AA6FRA6 & 1AA6FRC6, LH	1 1
4	N/A	Hydraulic Hose Assy., 10.5" – 1BA12FRA12 (2) (R-Port, RH) Hydraulic Hose Assy., 50" – 1BA12FRA12 (2) (R Port, LH)	1 1
5	N/A	Hydraulic Hose Assy., 19" – 1BA12FRA12 & 1BA12FRB12 (L-Port, RH) Hydraulic Hose Assy., 46.5" – 1BA12FRA12 (R-Port, LH)	1 1
6	N/A	Hydraulic Fitting, FF1852T1212S (2 per Side, L & R-Port)	4
7	N/A	Hydraulic Fitting,	2
8	Included in Item 2	Brake Release, 12mm x 110 mm Stud	1

Note: Picture shows RH Rear Drive Motor with brake release assembly attached. Brake release, Items #2 & #8, are to be used only to release Drive Motor Brake if needed. Items must be removed for normal operation.

PRESSURE MANIFOLD VIEW

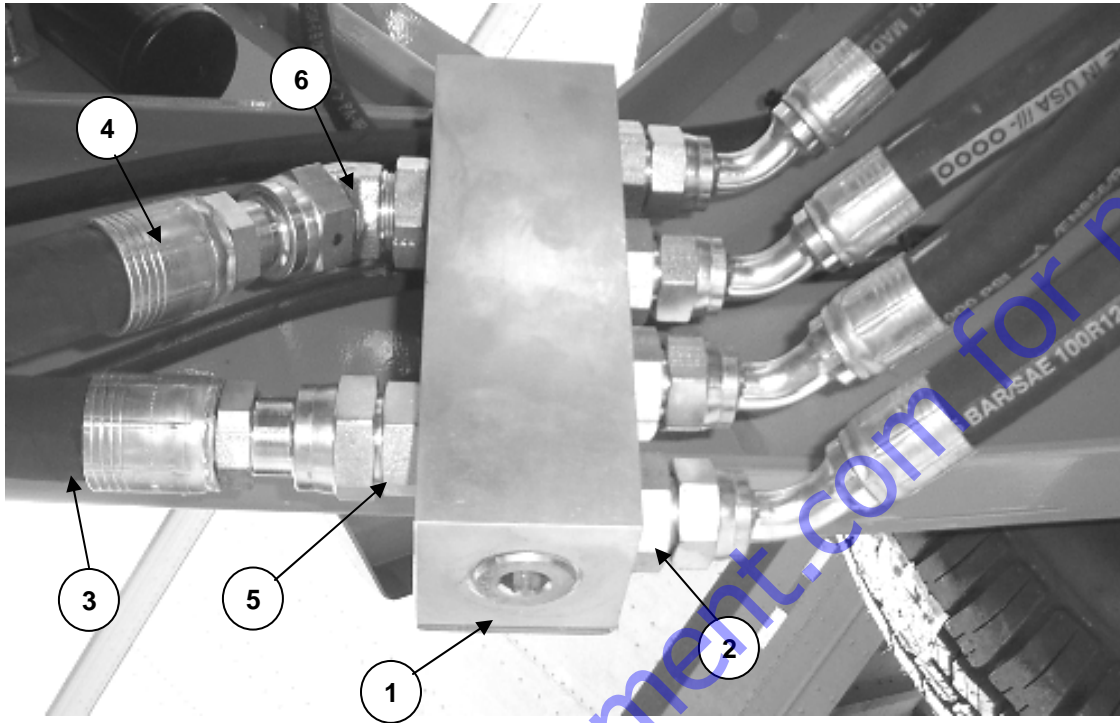

ITEM	PART NUMBER	DESCRIPTION	QUANTITY
1	325017	Pressure Manifold	1
2	NA	Hydraulic Fitting, FF1852T1216S	4
3	NA	Hydraulic Hose Assy., 27" – 1BA16FR16 & 1BA16FRB16	1
4	NA	Hydraulic Hose Assy., 28" – 1BA16FR16 & 1BA16FRB16	1
5	NA	Hydraulic Fitting, FF1852T1616S	1
6	NA	Hydraulic Fitting, FF2068T1616S	1

STEERING MOTOR VIEW

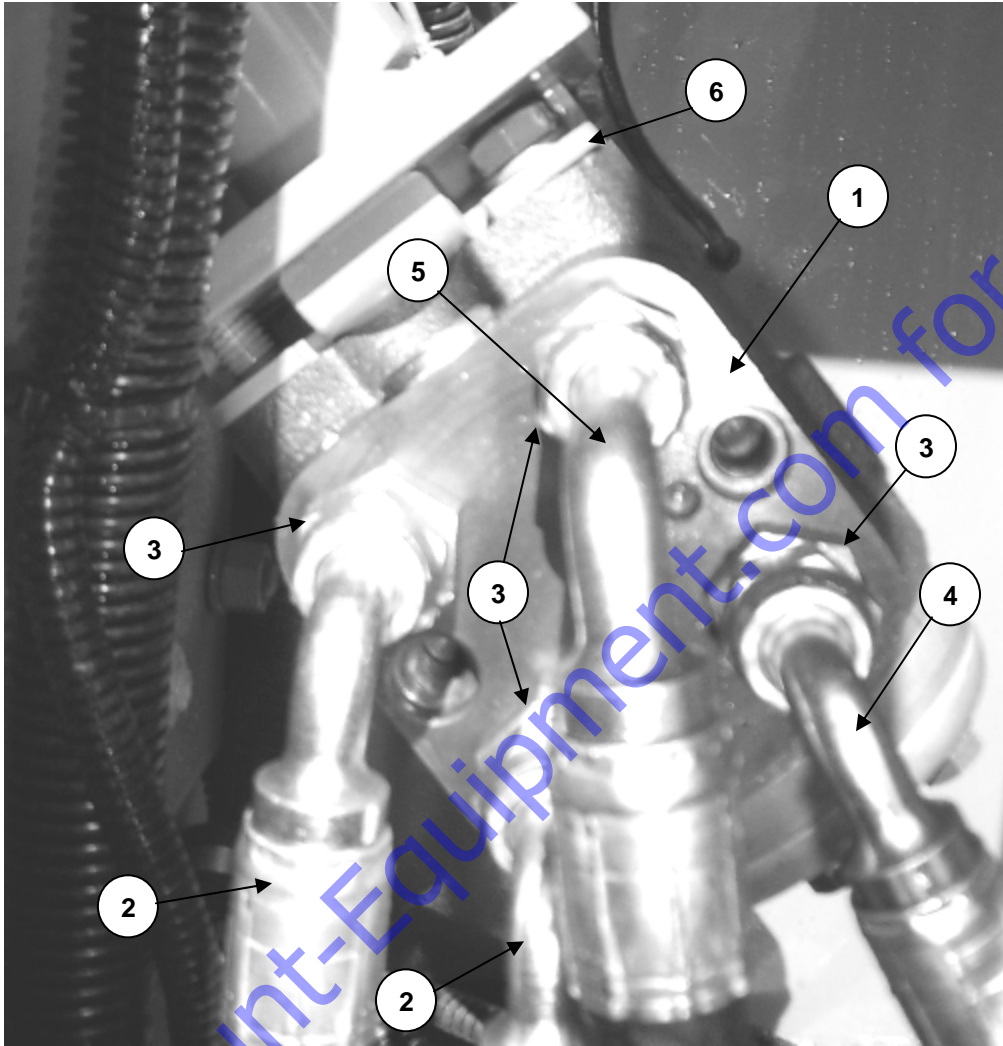

ITEM	PART NUMBER	DESCRIPTION	QUANTITY
1	325009	Steering Motor	1
2	NA	Hydraulic Hose Assembly, 20" – 1AA6FR6 & 1AA6FRB6	2
3	NA	Hydraulic Fitting, FF1852T0608S	4
4	NA	Hydraulic Hose Assembly, 18" – 1AA6FR6 & 1AA6FRB6	1
5	NA	Hydraulic Hose Assembly, 12" – 1AA6FRB6 & 1AA6FRC6	1
6	203250	Power Steering Unit Mount	1

STEERING CYLINDER VIEW

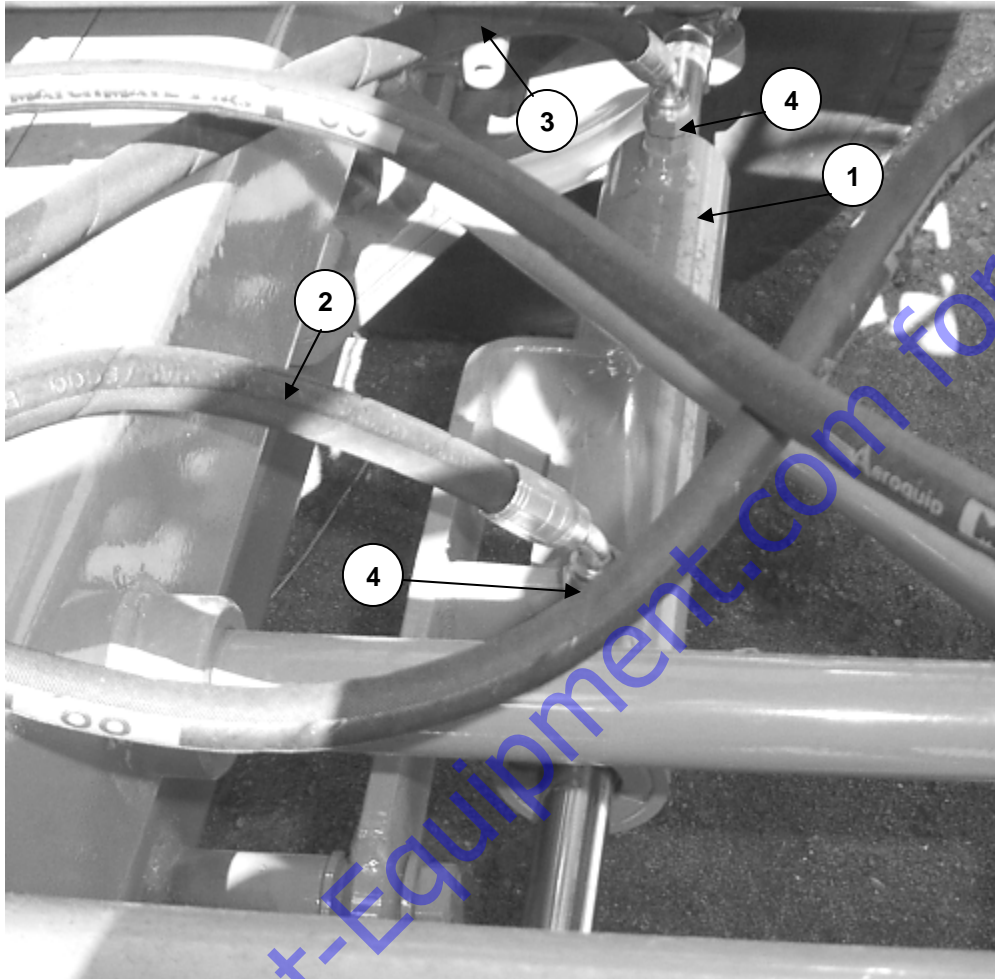

ITEM	PART NUMBER	DESCRIPTION	QUANTITY
1	See Front Axle View	Steering Cylinder	1
2	NA	Hydraulic Hose Assembly, 66" – 1AA6FRA6 & 1AA6FRB6	1
3	NA	Hydraulic Hose Assembly, 74" – 1AA6FRA6 & 1AA6FRB6	1
4	NA	Hydraulic Fitting, FF1852T0606S	2

BOLSTER ASSEMBLY

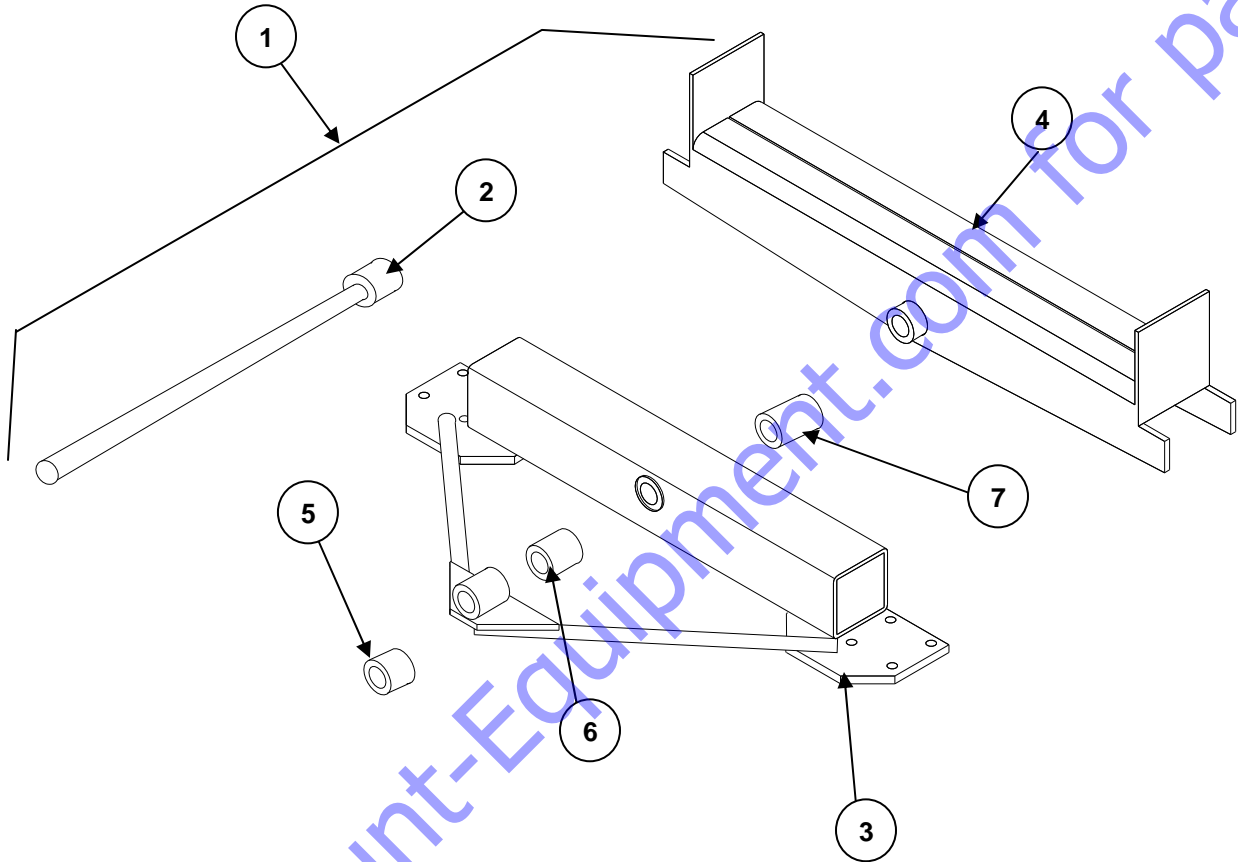

ITEM	PART NUMBER	DESCRIPTION	QUANTITY
1	752002	Bolster Assembly, Complete	1
2	203002	Bolster Pin	1
3	852002	Bolster A-Frame Assembly	1
4	852003	Bolster Support	1
5	309507	Oil Light Bushing, 1 1/4" x 1 1/2" x 1 1/2"	1
6	309505	Oil Light Bushing, 1 1/4" x 1 1/2" x 2"	1
7	309506	Oil Light Bushing, 1 1/4" x 1 1/2" x 2 1/4"	1

BRAKE CONTROL ASSEMBLY

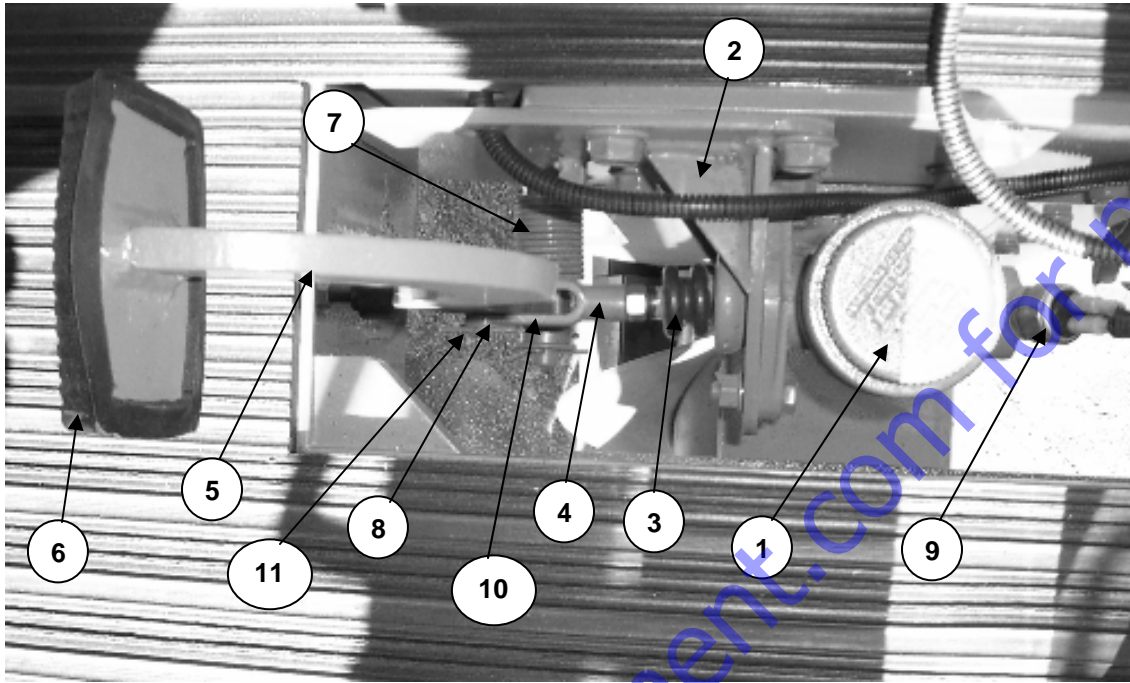

ITEM	PART NUMBER	DESCRIPTION	QUANTITY
1	B-240-R	Master Cylinder	1
2	855188	Master Cylinder Mount	1
3	B-284	Rubber Boot	1
4	401216	Push Rod	1
5	855191	Brake Pedal	1
6	B-241-R	Brake Pedal Pad	1
7	344460	Tension Spring	1
8	205197	Pedal Bushing	2
9	BLS-15	Brake Light Switch	1
10	B-27084A	Clevis	1
11	HC-229-R	Clevis Pin	1

4W BROOM FRONT AXLE ASSEMBLY

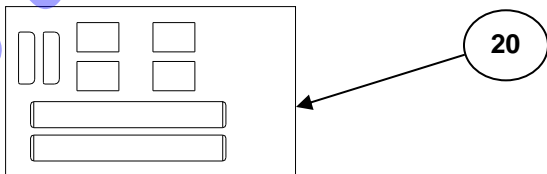
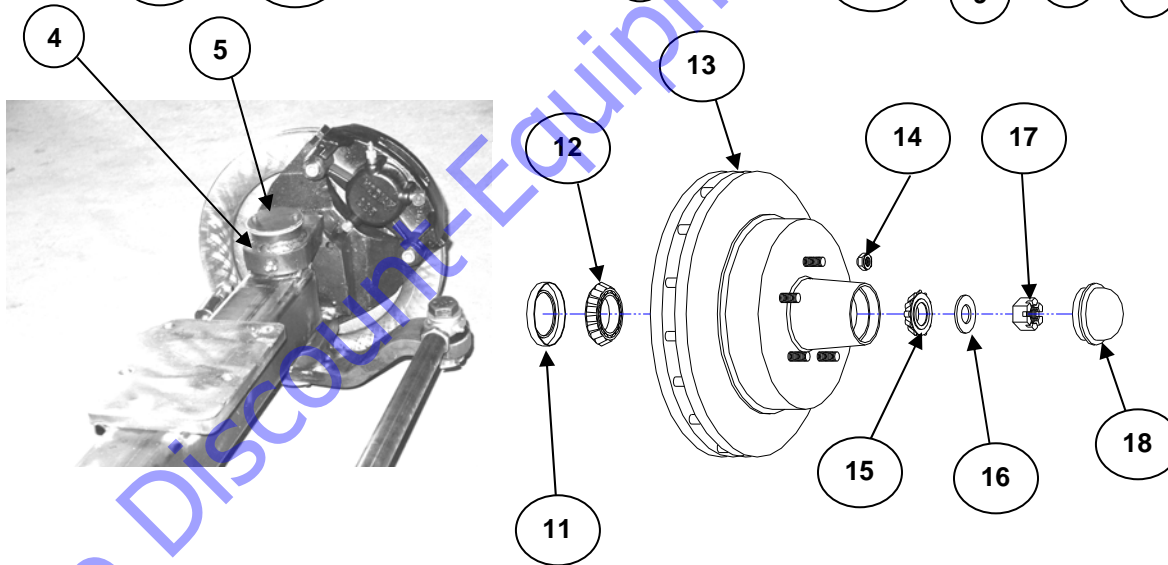
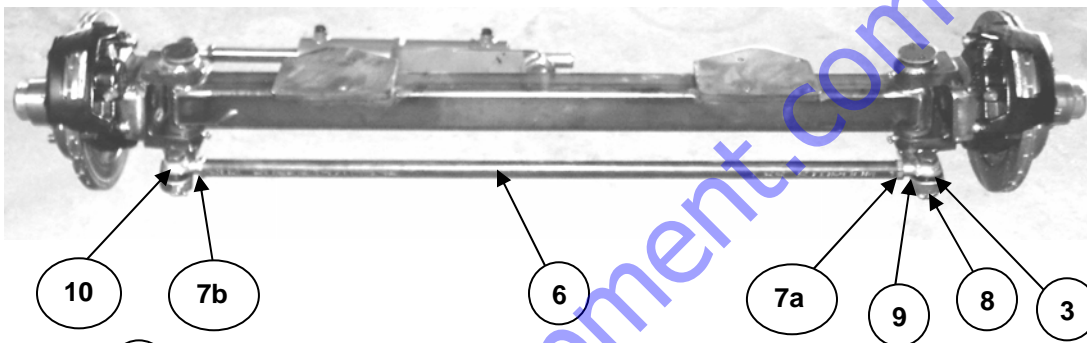
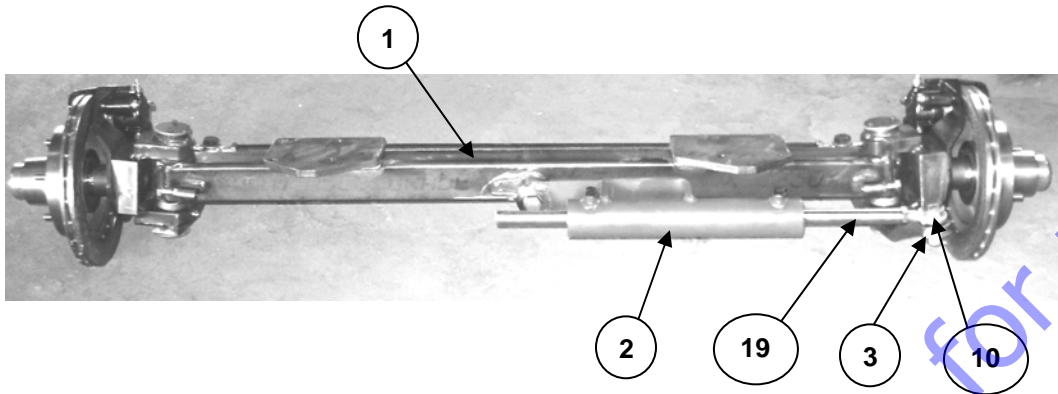

4W BROOM FRONT AXLE ASSEMBLY

ITEM	PART NUMBER	DESCRIPTION	QUANTITY
1	752501	Front Axle Assembly, 6 Lug x 5 1/2	1
2	203526	Steering Cylinder Assembly	1
3	203552	Thrust Bearing	1
4	852507	Knuckle w/ Spindle, LH	1
	852506	Knuckle w/ Spindle, RH	1
5	203512	King Pin Cap	2
6	203514	Tie Rod Tube	1
7a	400126A	Jam Nut, RH Thread	1
7b	BF4471	Jam Nut, LH Thread	1
8	203520	Tie Rod End, RH Thread	1
9	203523	Lock Nut	2
10	203521	Tie Rod End, LH Thread	1
	203520	Tie Rod End, RH Thread	1
11	203551	Seal	2
12	BF4461X	Inner Bearing Kit	2
13	203543	Hub Assembly, 5 Lug x 5 1/2	2
	203544	Hub Assembly, 6 Lug x 5 1/2	2
14	69957B	Lug Nut	10
15	752547	Outer Bearing Kit	2
16	400195	Washer	2
17	203549	Lock Nut	2
18	203550	Hub Cap	2
19	400126	Jam Nut, RH Thread	1
20	203509	King Pin Kit	1
NS	203553	Steering Cylinder Seal Kit	1
NS	304039	Wheel – 6 Lug	1

5200-6000 LB FRONT BRAKE ASSEMBLY

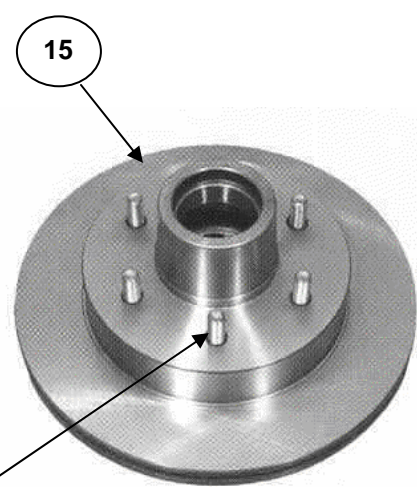
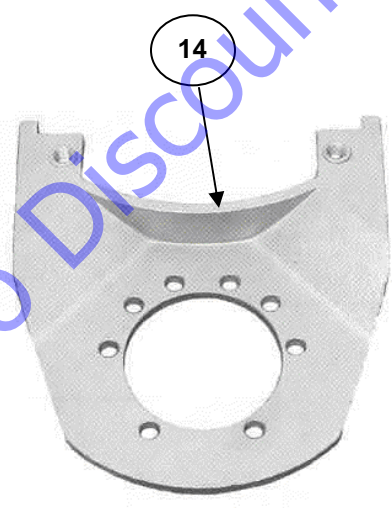
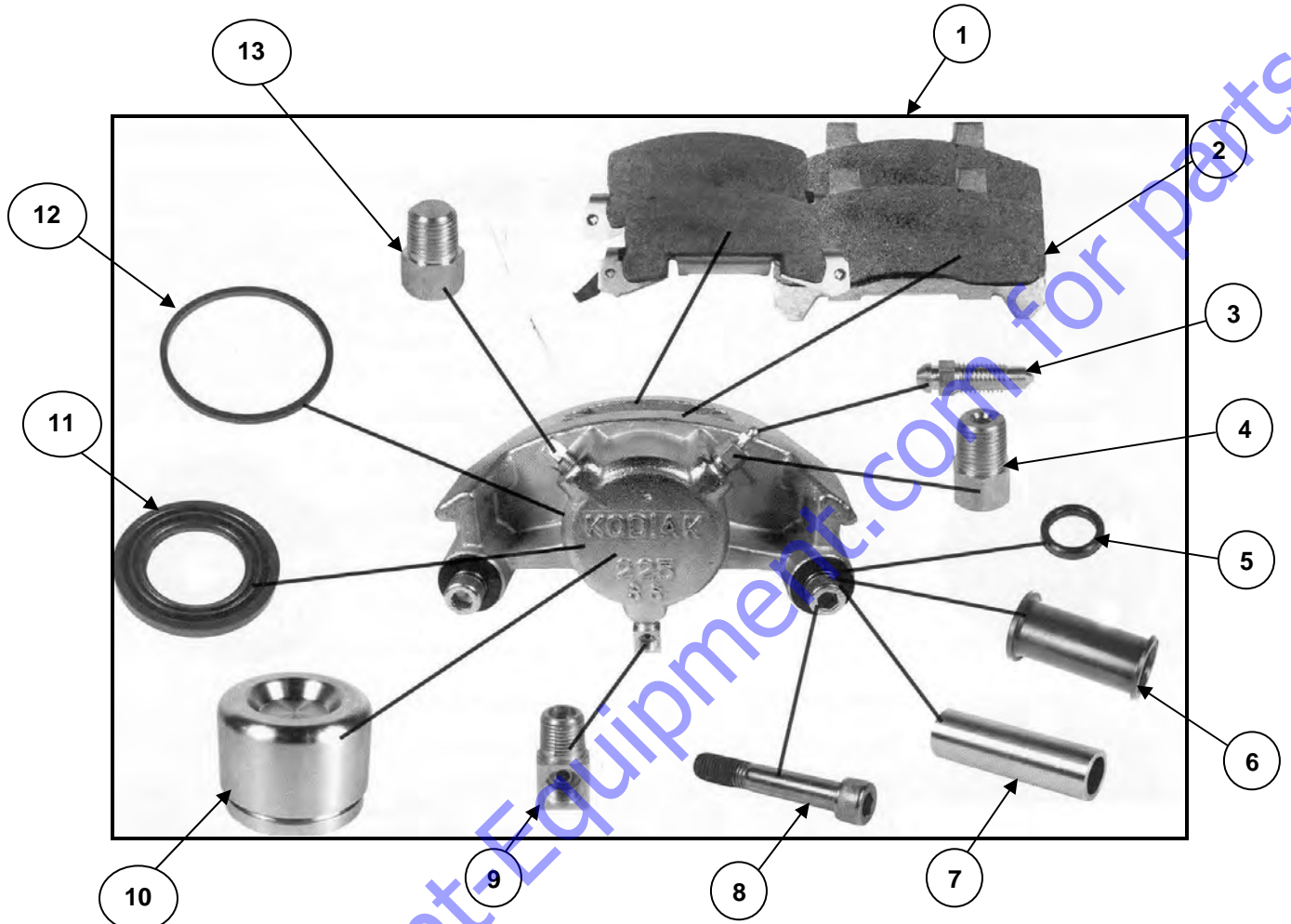

5200-6000 LB FRONT BRAKE ASSEMBLY

ITEM	PART NUMBER	DESCRIPTION	QUANTITY
1	203554	Complete Caliper Assembly w/ Pads	1
2	203530	Friction Pads, Organic	1
3	203531	Brass Bleed Screw, 1/4" – 28	1
4	203532	Brass Bleed Screw Adapter, 1/8"	1
5	203533	Guide Bolt Sleeve O-Ring	1
6	203534	Guide Bolt Rubber Sleeve	1
7	203535	Guide Bolt Stainless Steel Sleeve	1
8	203536	Guide Bolt (M11 x 1.5) w/ Thread Locker	1
9	203537	90° 1/8" NPT to 3/16" F.I.F.	1
10	203538	Caliper Piston, 2 1/4" Stainless Steel	1
11	203539	Rubber Dust Boot	1
12	203540	Piston Rubber Seal	1
13	203541	1/8" NPT Brass Plug	1
14	203542	Caliper Mounting Bracket	1
15	203543	12" Integral Rotor w/ Hub, 5 Lug x 5 1/2	1
	203544	12" Integral Rotor w/ Hub, 6 Lug x 5 1/2	1
16	203555	Wheel Stud	5 or 6
NS	FA-306-R	Brake Hose	2

M-46 HYDROSTAT VIEW

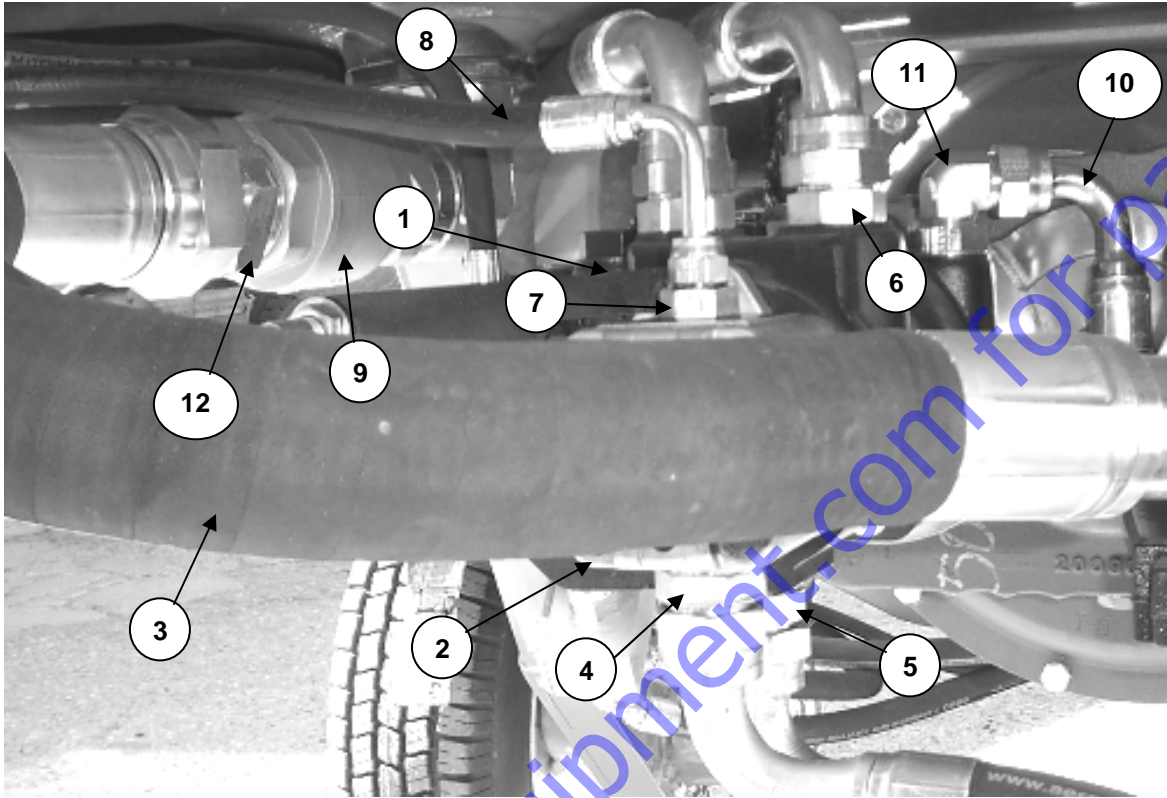

ITEM	PART NUMBER	DESCRIPTION	QUANTITY
1	325003	M-46 Hydrostat	1
2	325005	Steering Pump	1
3	N/A	Hydraulic Hose Assy., 25" – 1GA32FJ32 & 1 G32FLA32	1
4	N/A	Hydraulic Fitting, FF1852T1612S	1
5	N/A	Hydraulic Fitting, FF1852T1616S	1
6	N/A	Hydraulic Fitting, FF1852T1216S	2
7	N/A	Hydraulic Fitting, FF1852T0610S	1
8	N/A	Hydraulic Hose Assy., 76" – 1AA6FRB6 & 1AA6FRC6	1
9	N/A	2" Ball Valve	1
10	N/A	Hydraulic Hose Assy., 28" – 1AA12FRB12 (2)	1
11	N/A	Hydraulic Fitting, FF1868T1212S	1
12	N/A	Hydraulic Fitting, 2021-32-32	1

M-45 PISTON PUMP VIEW

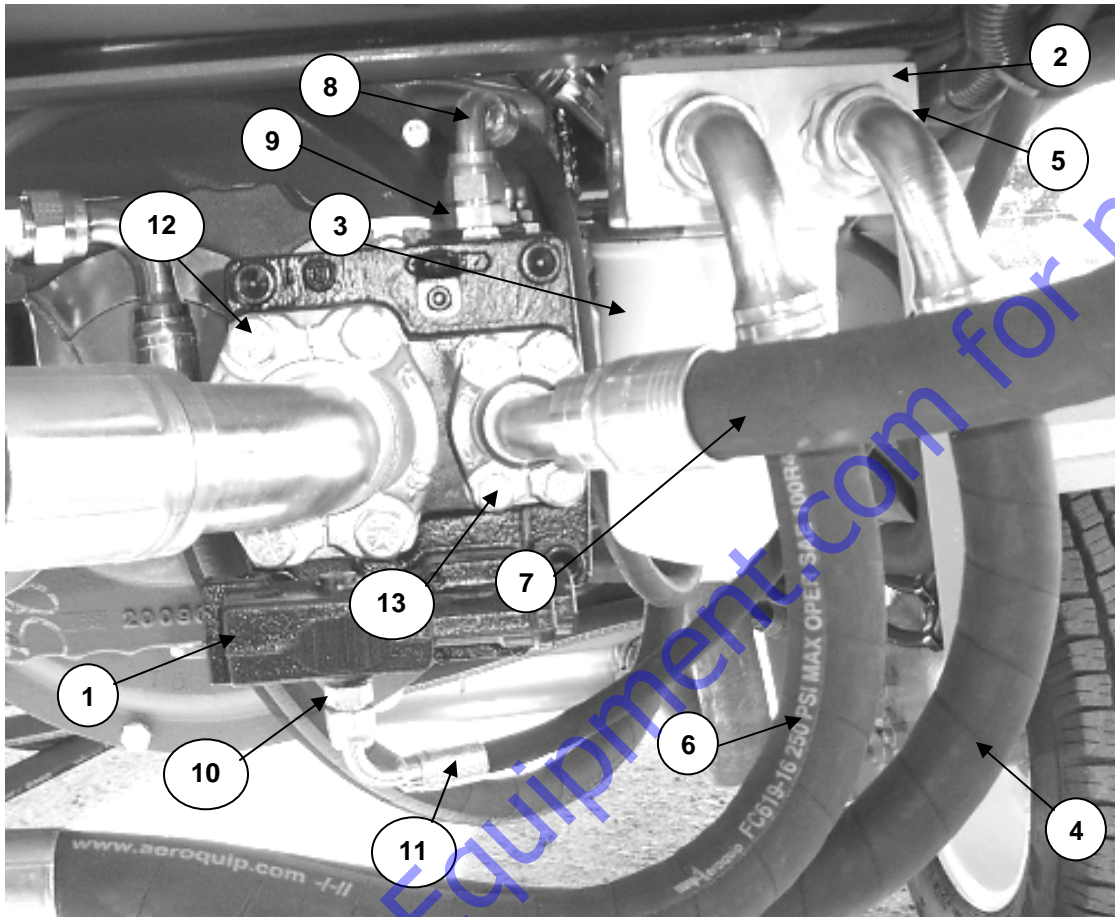

ITEM	PART NUMBER	DESCRIPTION	QUANTITY
1	325004	M-45 Piston Pump, 75cc	1
2	325015	Suction Manifold	1
3	325020	Hydraulic Oil Filter	2
4	N/A	Hydraulic Hose Assy., 22" – 1GA16FRB16 (2)	1
5	N/A	Hydraulic Fitting, FF1852T1616S	2
6	N/A	Hydraulic Hose Assy., 19" – 1GA16FRB16	1
7	N/A	Hydraulic Hose Assy., 48.5" – 1BA16FRB16 & 1B16FLA16	1
8	N/A	Hydraulic Hose Assy., 27" – 1AA8FRB8 (2)	1
9	N/A	Hydraulic Fitting, FF1852T0810S	1
10	N/A	Hydraulic Fitting, FF1852T0404S	1
11	N/A	Hydraulic Hose Assy., 76" – 1AA4FRB4 & 1AA4FRC4	1
12	N/A	Flange Kit, FF593-449-74446-32	1
13	N/A	Flange Kit, FF593-449-74446-16	1

PVG VALVE VIEW

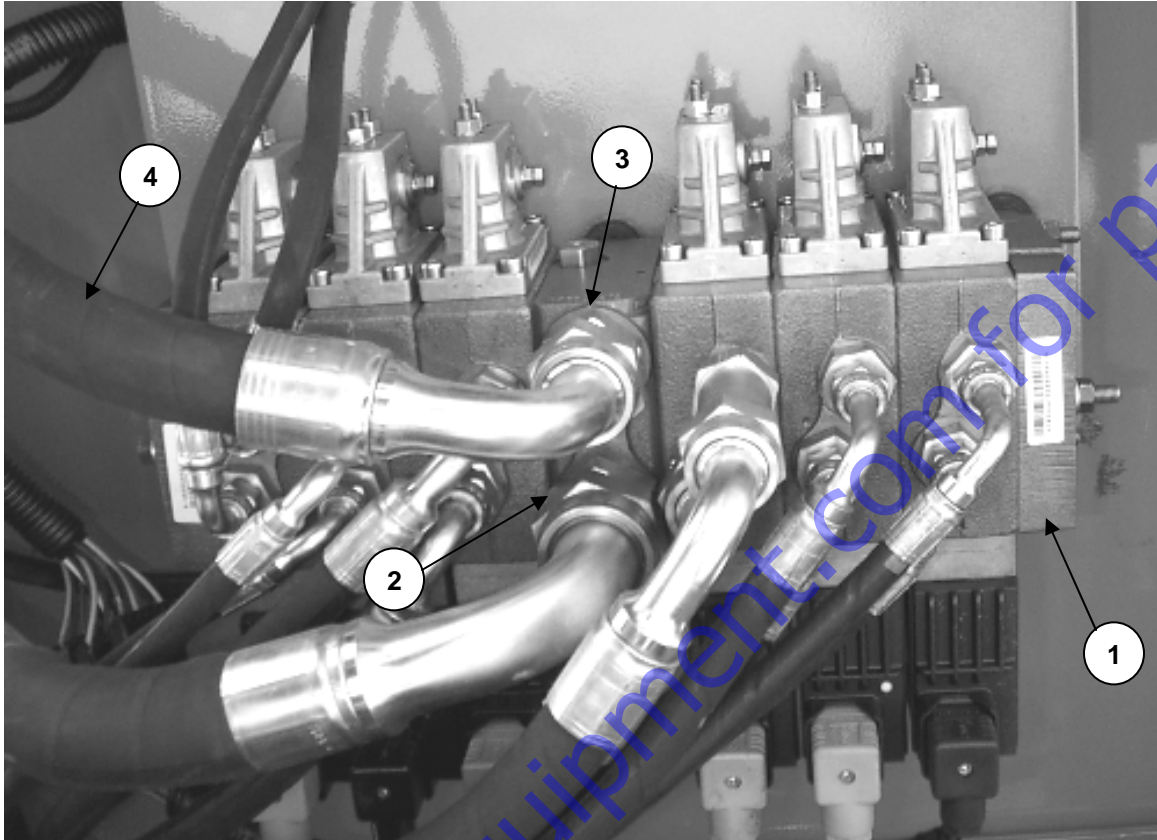

ITEM	PART NUMBER	DESCRIPTION	QUANTITY
1	325006	PVG32/6 Control Valve	1
2	N/A	Hydraulic Fitting, FF1852T1616S	1
3	N/A	Hydraulic Fitting, FF1852T2016S	1
4	N/A	Hydraulic Hose Assy., 7.5" – 1GA20FR20 & 1GA20FRB20	1

HYDRAULIC TANK VIEW

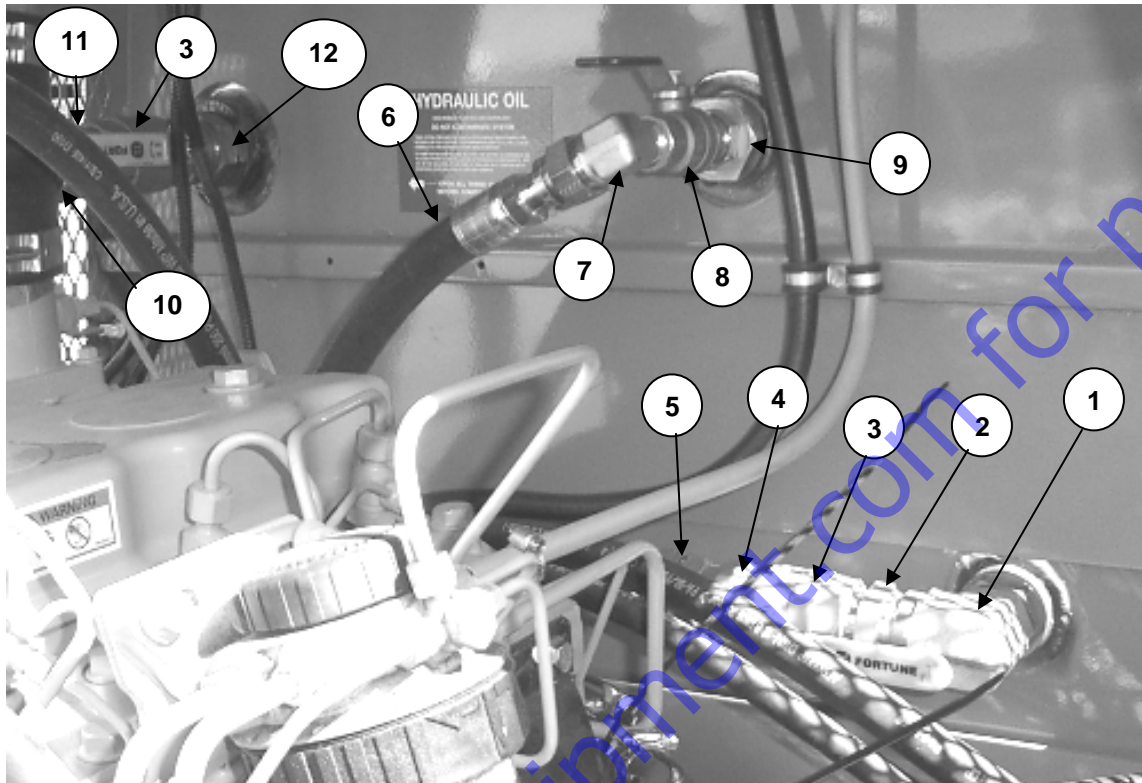

ITEM	PART NUMBER	DESCRIPTION	QUANTITY
1	N/A	Hydraulic Fitting – Elbow, 6805-20-20FG	1
2	N/A	Hydraulic Fitting, 2083-20-20S	1
3	306538	1 1/4" Ball Valve – 1/4 Turn Valve	1
4	N/A	Hydraulic Fitting, FF2031T2020S	1
5	N/A	Hydraulic Hose Assy., 12"–1GA20FR20 & 1GA20FRB20	1
6	N/A	Hydraulic Hose Assy., 65" – 1AA12FR12 (2)	1
7	N/A	Hydraulic Fitting, FF2032T1212S	1
8	306535	3/4" Ball Valve	1
9	N/A	Hydraulic Adapter Fitting, 6401-12-12	1
10	N/A	Hydraulic Hose Assy., 26" – 1GA20FR20 & 1GA20FRA20	1
11	N/A	Hydraulic Adapter Fitting, FF2031T2020S	1
12	N/A	Hydraulic Adapter Fitting, 6401-20-20	1

CASE DRAIN MANIFOLD VIEW

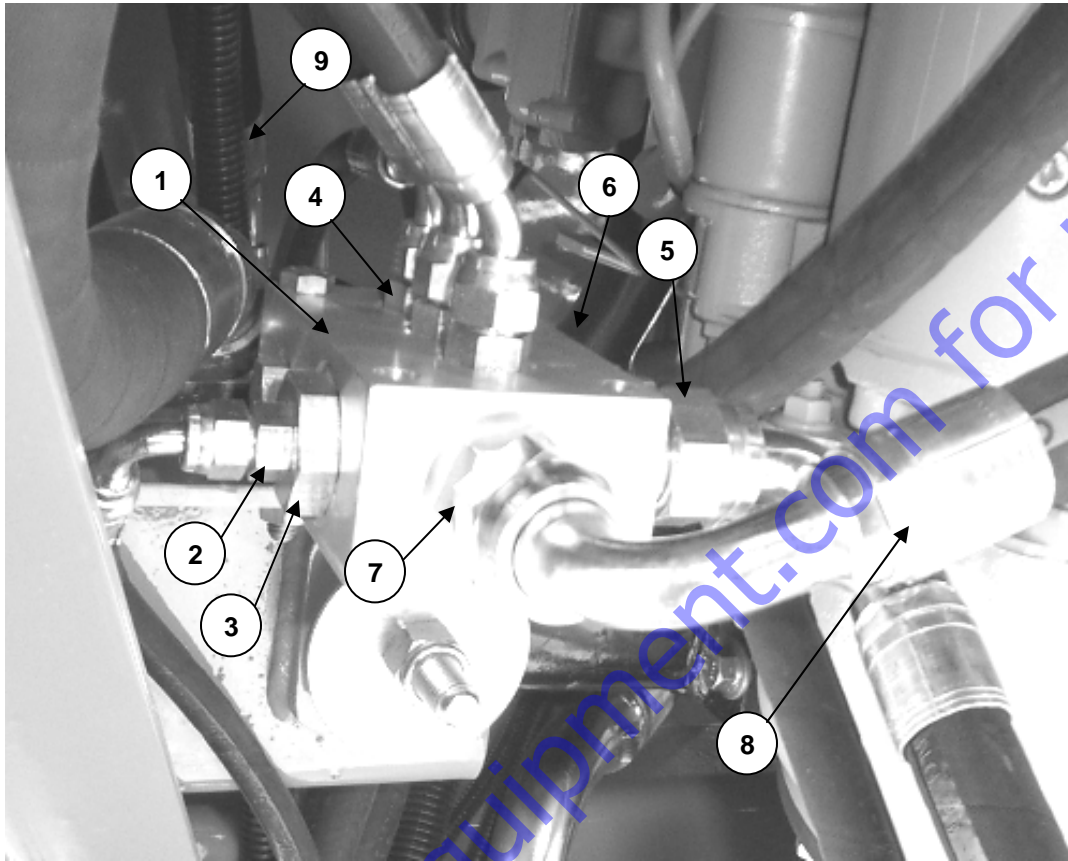

ITEM	PART NUMBER	DESCRIPTION	QUANTITY
1	325016	Case Drain Manifold	1
2	N/A	Hydraulic Adapter, FF1852T0406S	1
3	N/A	Hydraulic Bushing, FF1010-1206S	1
4	N/A	Hydraulic Fitting, FF1852T0606S	3
5	N/A	Hydraulic Fitting, FF1852T1212S	1
6	N/A	Hydraulic Fitting (Port 7), FF1852T0812S	1
7	N/A	Hydraulic Fitting, FF1852T1212S (3054B Cat Engine Only)	1
7	N/A	Hydraulic Fitting, FF1868T1212S (3054C Cat Engine Only)	1
8	N/A	Hydraulic Hose Assy., 40" – 1AA12FR12 & 1AA12FRB12	1
9	N/A	Hydraulic Hose Assy., 93" – 1AA6FRA6 & 1AA6FRB6 Hydraulic Fitting (Port 5), FF1852T0612S	1 1

CORE LIFT CYLINDER VIEW

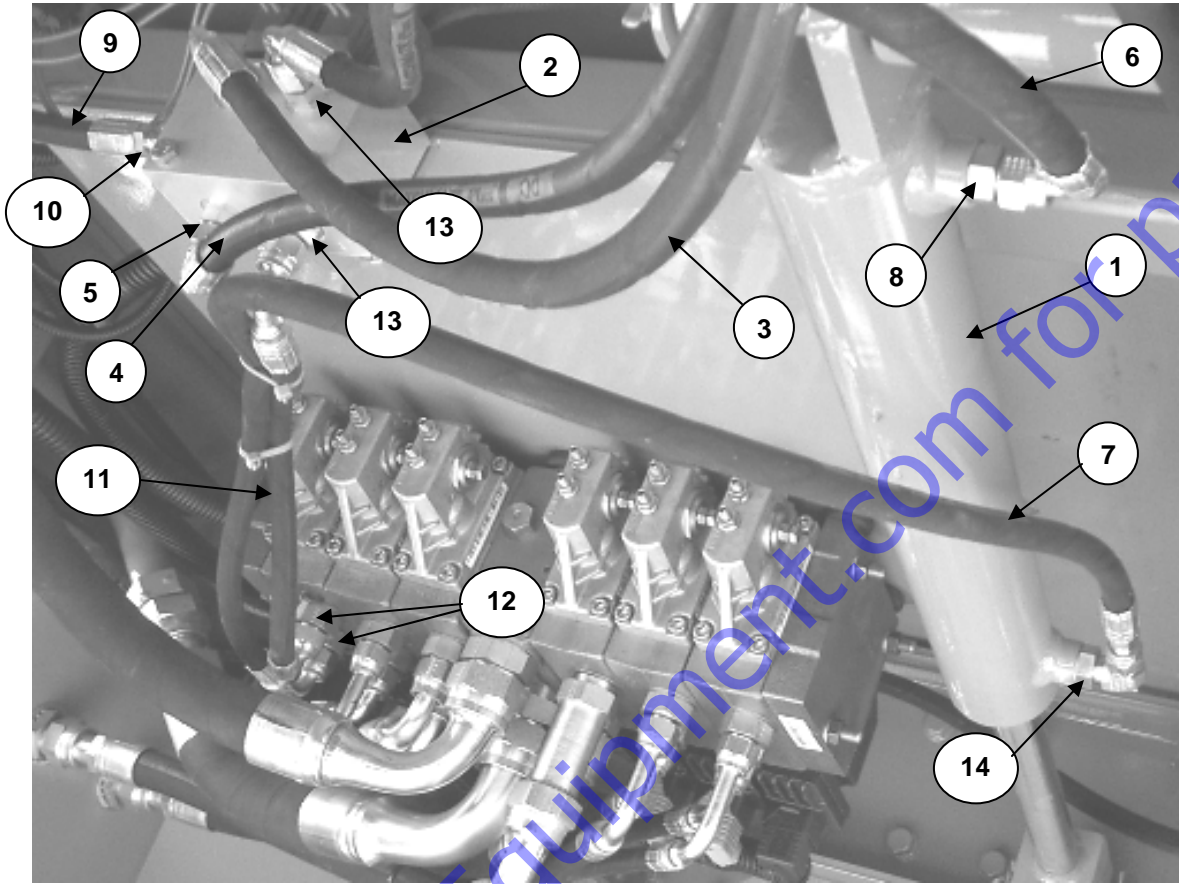

ITEM	PART NUMBER	DESCRIPTION	QUANTITY
1	325014	Core Lift Cylinder, 2" x 12"	1
2	325019	Dual Locking Valve – Lift Lock Solenoid	1
3	N/A	Hydraulic Hose Assy., 43" – 1AA4FR4 & 1AA4FRB4	1
4	N/A	Hydraulic Hose Assy., 88" – 1AA4FRB4	1
5	N/A	Hydraulic Fitting, FF1852T0406S	1
6	N/A	Hydraulic Hose Assy., 20" – 1AA4FRB4 (2)	1
7	N/A	Hydraulic Hose Assy., 39.5" – 1AA4FR4 & 1AA6FRB4	1
8	N/A	Hydraulic Fitting, FF1852T0406S	1
9	N/A	Hydraulic Hose Assy., 63" – 1AA4FR4 & 1AA4FRB4	1
10	N/A	Hydraulic Fitting, FF1852T0406S	1
11	N/A	Hydraulic Hose Assy., 14" – 1AA4FRB4 & 1AA6FRB4	1
12	N/A	Hydraulic Fitting, FF1852T0610S	2
13	N/A	Hydraulic Fitting, FF1852T0406S	1
14	N/A	Hydraulic Fitting, FF1868T0406S	1

GEAR BOX ASSEMBLY

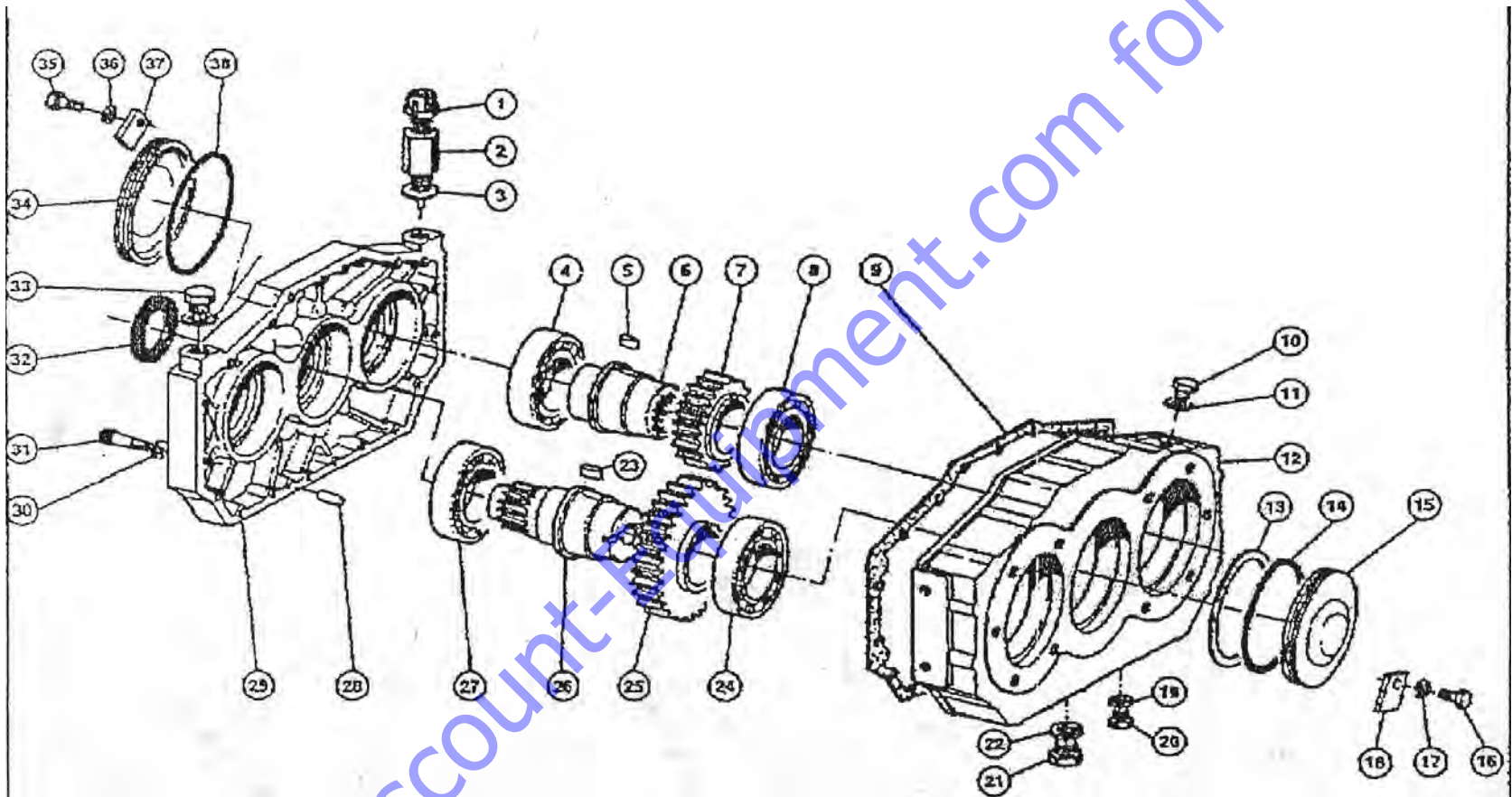

Go to Discount-www.discount-assembly.com for parts

GEAR BOX ASSEMBLY

ITEM	PART NUMBER	DESCRIPTION	QUANTITY
1	2070106	Oil Gauge	1
4	4605257	Ball Bearing	2
5	4620054	Key	2
6	2021180	Driven Shaft	2
7	2061243	Gear	2
8	4605257	Ball Bearing	2
9	4574013	Silicone Sealant Tube	1
12	2009044	Housing	1
13	2013240	Shim	X
14	4598030	O-Ring	1
15	2010119	Plate	1
21	4588040	Plug	1
22	4609020	Washer	1
23	4620054	Key	1
24	4605257	Ball Bearing	1
25	2061243	Gear	1
26	2021179	Main Shaft	1
27	4605257	Ball Bearing	1
28	4614014	Pin	1
29	2010117	Cover	1
30	4611108	Washer	19
31	4615227	Screw	19
32	4597165	Oil Seal	1
33	4588040	Plug	1
39	4609020	Washer	1

WATER SPRAY SYSTEM

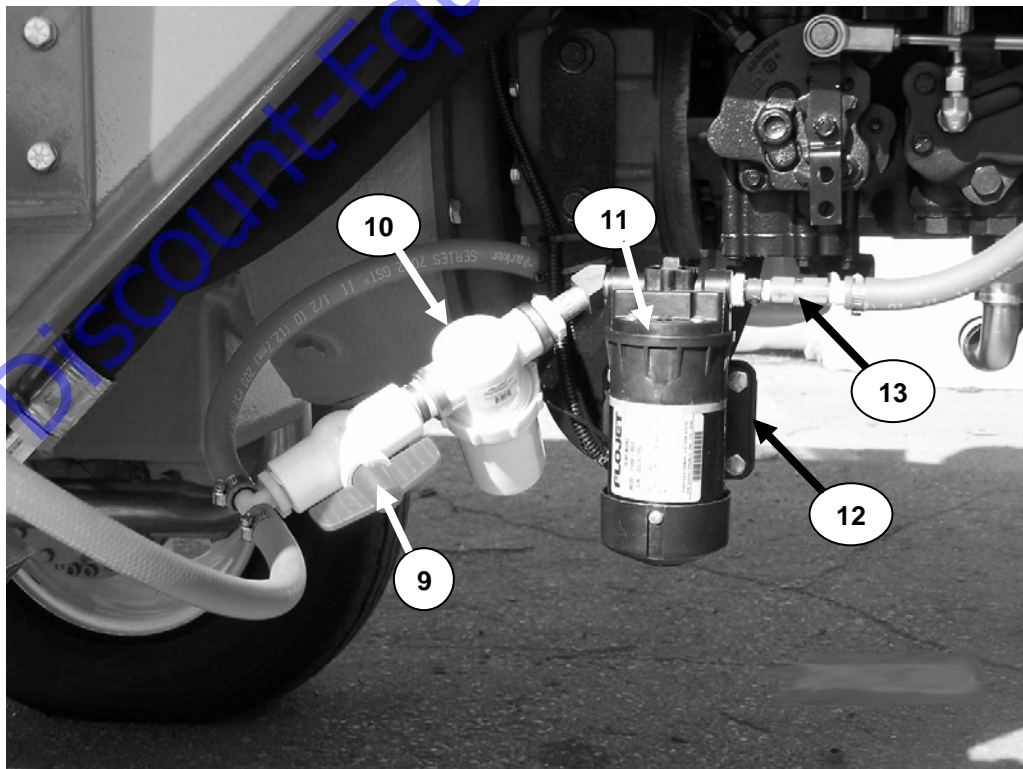
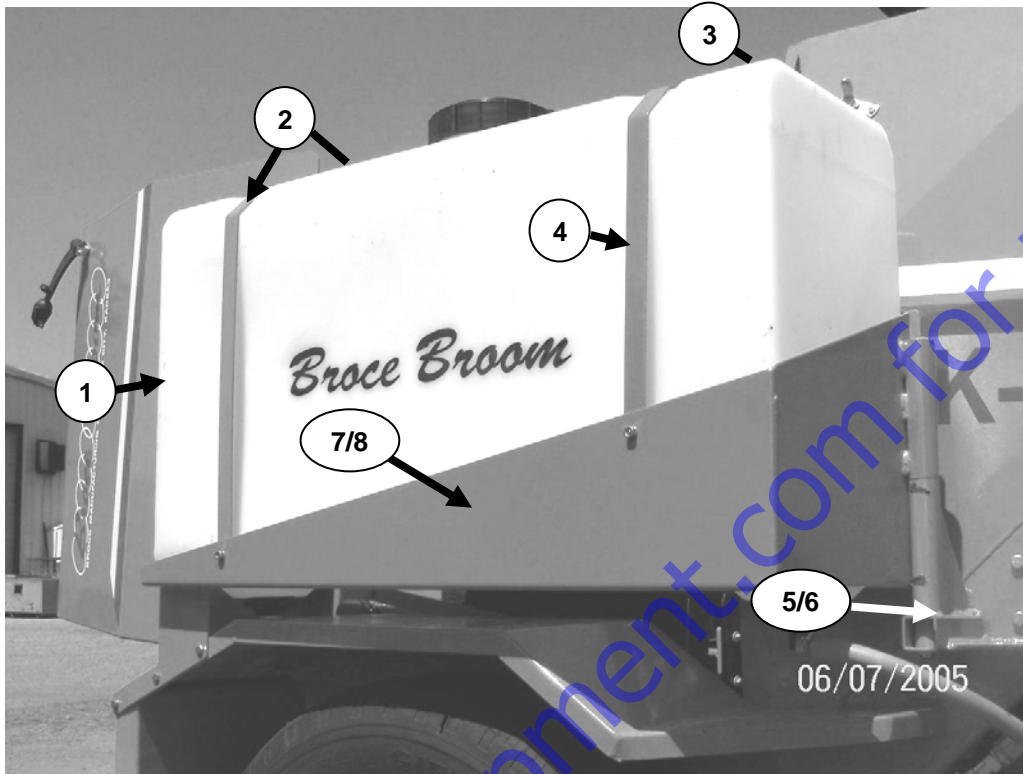

WATER SPRAY SYSTEM

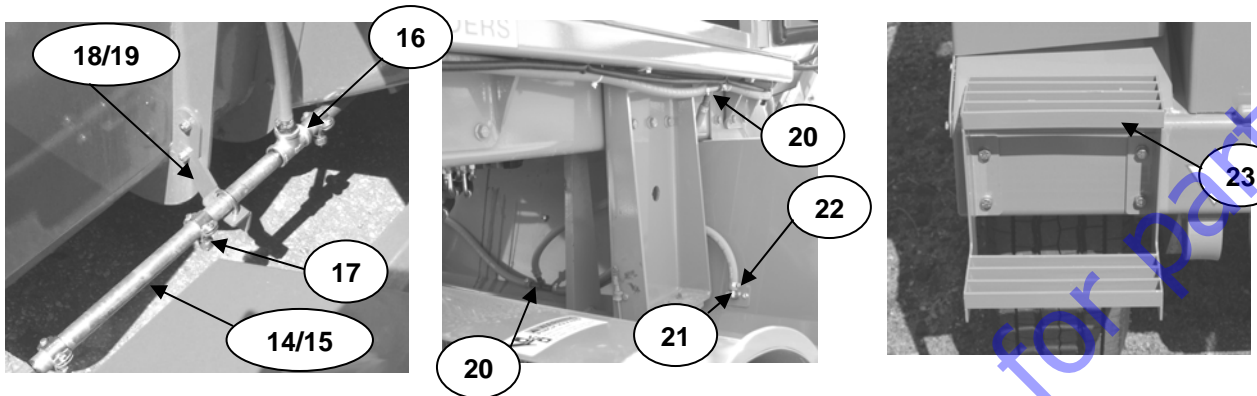

ITEM	PART NUMBER	DESCRIPTION	QUANTITY
1	344178	Water Tank	2
2	205254	Tank Strap Rear	4
3	205255	Tank Strap Front Inside	2
4	205253	Tank Strap Front Outside	2
5	855251	Frame Bracket Assembly RH	1
6	855252	Frame Bracket Assembly LH	1
7	855249	Tank Basket Assembly RH	1
8	855250	Tank Basket Assembly LH	1
9	344254	Ball Valve	1
10	WS-148	Inline Strainer, Complete	1
NS	1700-0044	Strainer Gasket	1
NS	3800-0025	Strainer Screen	1
NS	3351-0005	Strainer Cup	1
11	302402	Pump	1
12	205262	Pump Mounting Bracket	1
13	WS-178	Check Valve	1
14	205247	Spray Bar RH	1
15	205248	Spray Bar LH	1
16	306125	T-Fitting	1
17	WS-155	Nozzle Assembly	9
NS	WS-158	Nozzle Screen	9
NS	TP8002	Nozzle Spray Tip	9
NS	1458	Nozzle Cap	9
18	205245	Bracket RH	1
19	205246	Bracket LH	1
20	306901	Barb Tee 1/2"	2
21	306925	Brass Nozzle Housing	2
22	345007	Fitting, Hose Barb to 1/2 FNPT 90 Deg	2
23	855270	Water System Step	2

CAB ASSEMBLY

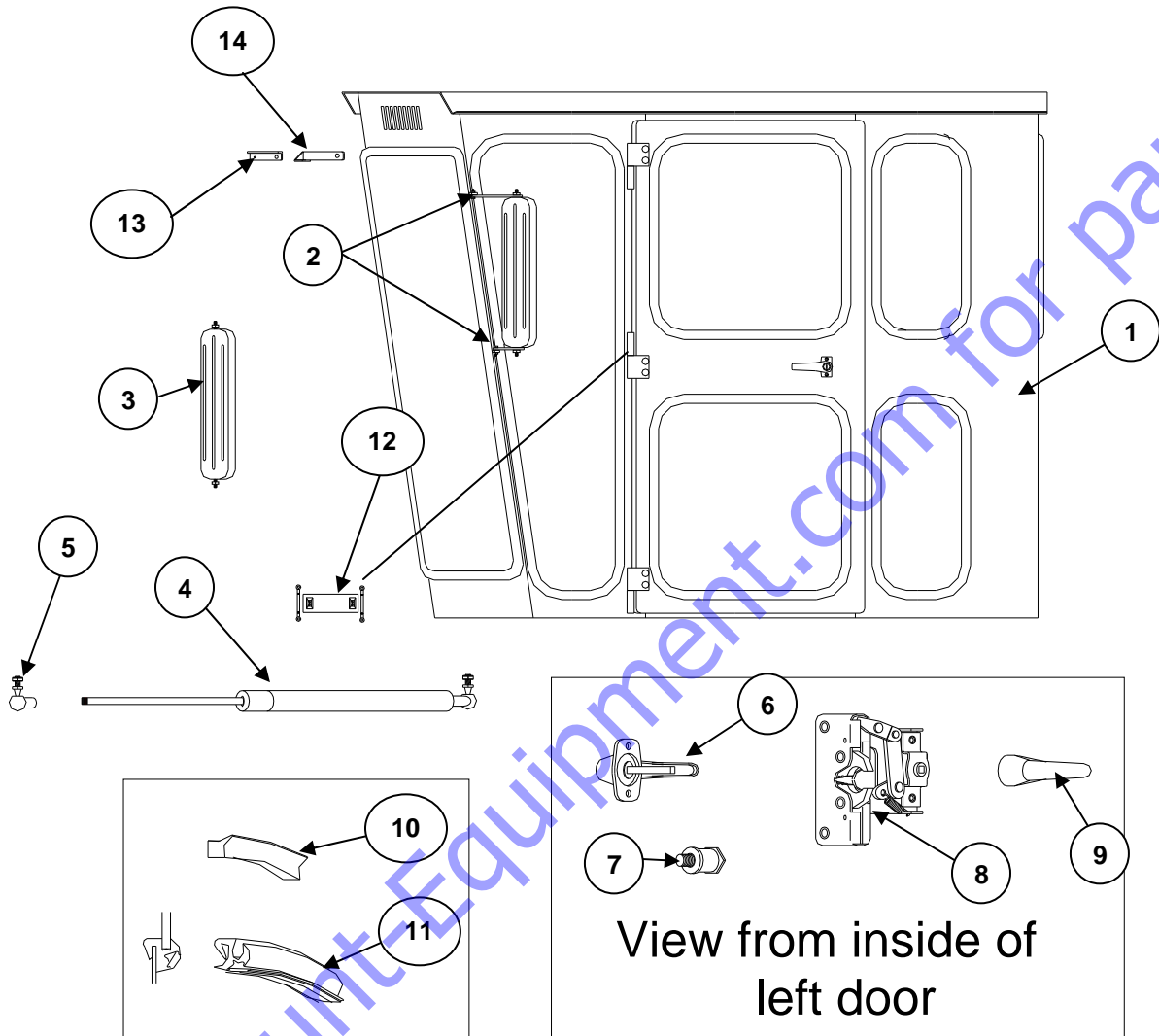

Go to DiscountEquipment.com for parts

CAB ASSEMBLY

ITEM	PART NUMBER	DESCRIPTION	QUANTITY
1	P-315-B	Cab Assembly, Complete	1
	P-344-K	Cab Keys, Sold as a Pair	1
2	202116	Mirror Bracket, 2 per side	4
3	P-353-R	West Coast Style Mirror, 1 per side	2
4	P-352-B	Strut, 1 per side	2
5	P-352-BA	Ball & Socket Assembly	2
6	P-344-R	Outside Door Handle	2
7	P-320-B	Striker Assembly	2
8	P-342-BL	Latch Assembly, LH	1
	P-342-BR	Latch Assembly, RH	1
9	P-354-B	Inside Door Handle	2
10	304082	Door Seal, 14' per door required	1
11	P-325-R	Offset Rubber Molding, As required	1
	P-316-R	Floor Mat, 5' x 4' Blank	1
12	K00002	Door Tether Strap, Inside (1 per side)	2
13	203268	Light Bracket Extension, LH	1
	203271	Light Bracket Extension, RH	1
14	203267	Light Bracket – Cab Mount, LH	1
	203272	Light Bracket – Cab Mount, RH	1

Note: Items 10 & 11 are sold by the foot. Floor mat is a “Cut to Fit” item.

CAB – FRONT VIEW

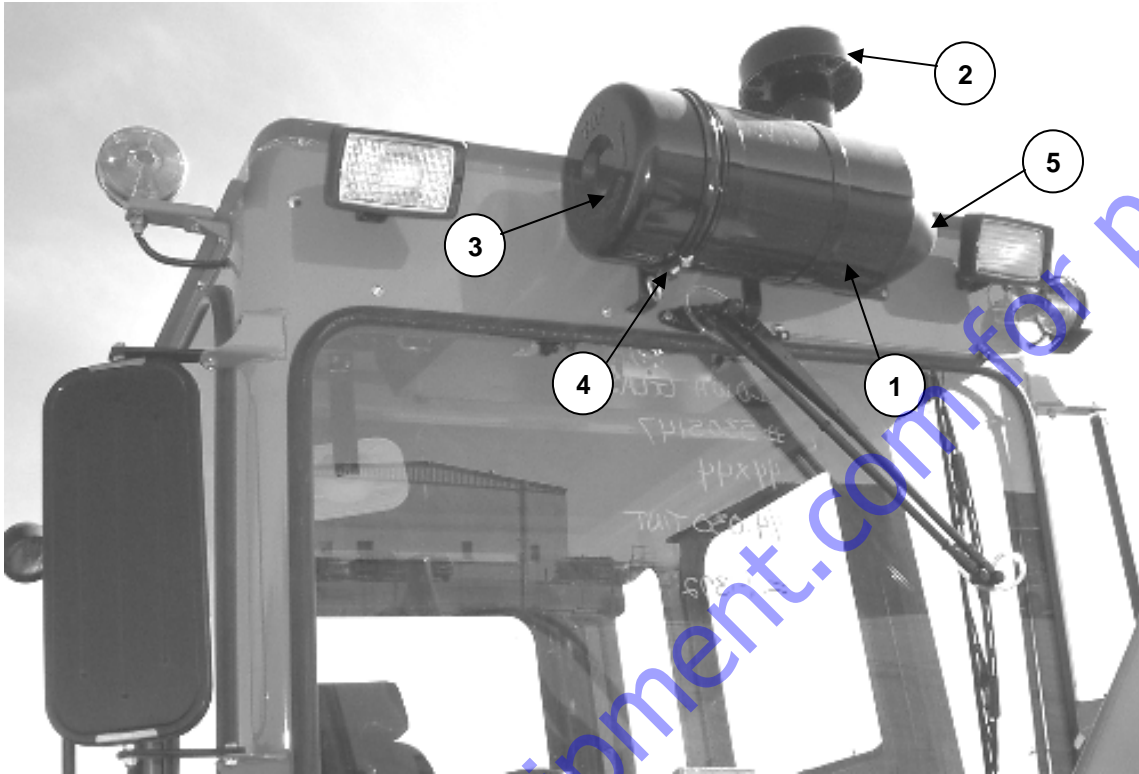

ITEM	PART NUMBER	DESCRIPTION	QUANTITY
1	AC-708-R	Air Cleaner Assembly	1
2	AC-785-R	Bonnet	1
3	P10-3113	End Cap	1
4	P00-3951	Clamp	1
5	110-20027	Flex Hose	1
NS	P10-2114	Vent	1
NS	AC-709-R	Filter	1

SEAT AND SUSPENSION COMPONENTS

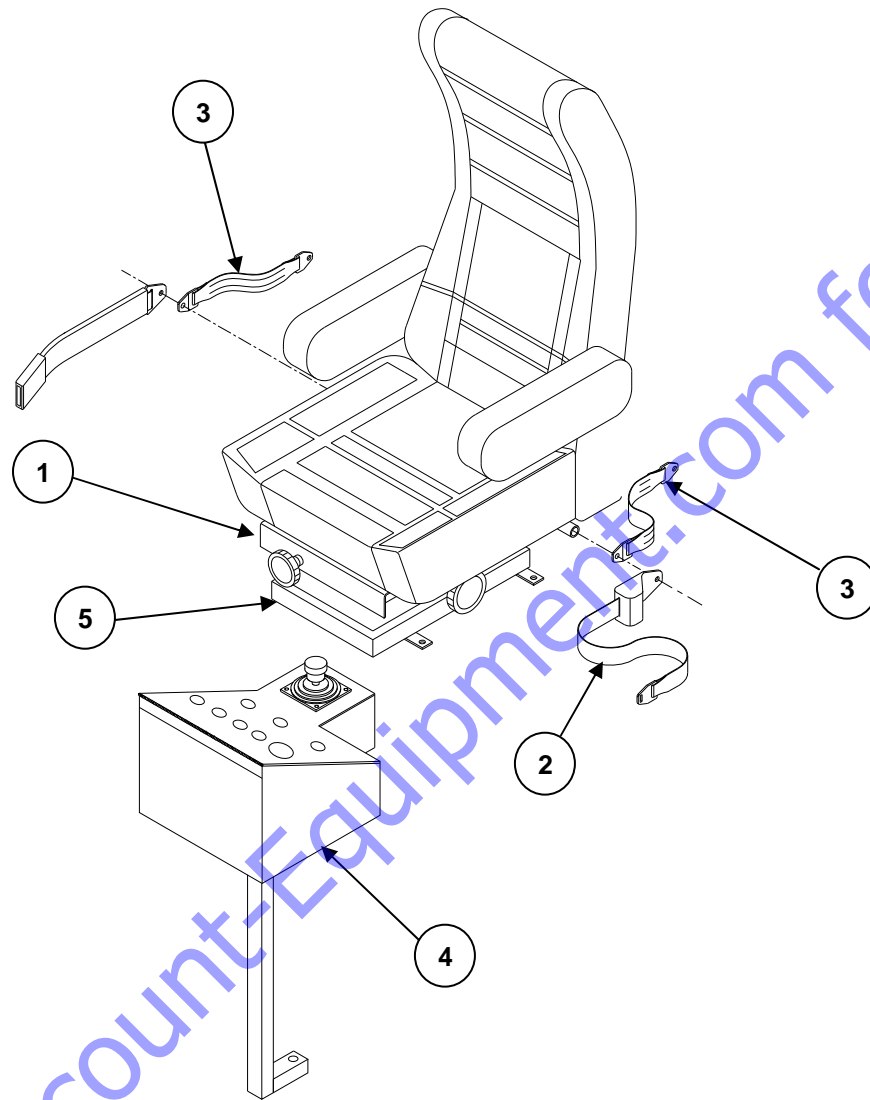

ITEM	PART NUMBER	DESCRIPTION	QUANTITY
1	BS-1050	Seat	1
2	C-211-R	Retractable Seat Belt (Shown)	1
	C-211-SH	Retractable Seat Belt w/ Shoulder Harness (Not Shown)	1
3	C-211-RT	Tether Strap Set (for use w/ Suspension Seat)	1
4	855182	Control Box Assembly	1
5	BS-1054	Suspension Assembly	1

BROOM/CONVEYOR CONTROL BOX

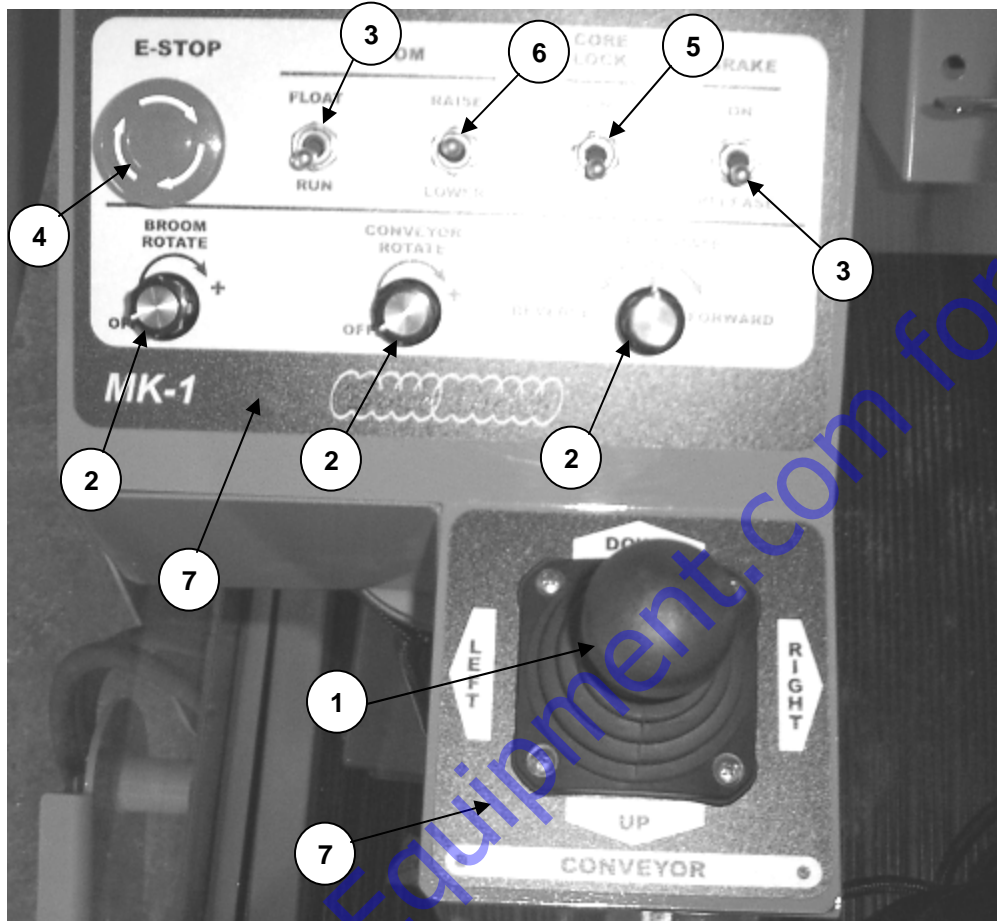

ITEM	PART NUMBER	DESCRIPTION	QUANTITY
1	307432	Conveyor Joystick Control	1
2	307417	Broom, Conveyor, & Auger Speed Pot Control	3
3	307416	Broom Float/Run & Emergency Brake Switches	2
4	307427	Emergency Stop Switch	1
5	307071	Core Lock On/Off Switch	1
6	307415	Broom Raise/Lower	1
7	311165	Control Panel Decals (Set of 2)	1

TRANSMISSION CONTROL BOX

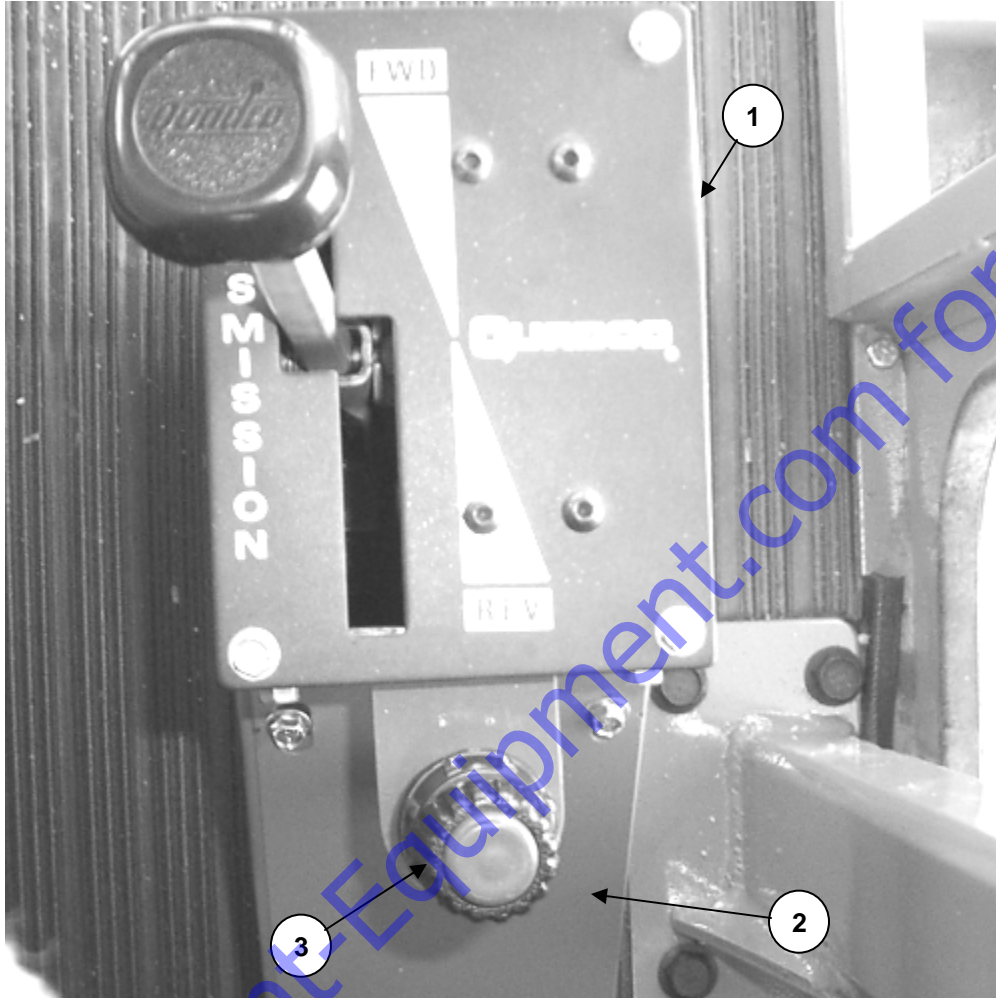

ITEM	PART NUMBER	DESCRIPTION	QUANTITY
1	855171	Transmission Hand Control Box	1
2	855172	Hand Control Box Cover	1
3	309456	Throttle Cable	1

HYDROSTATIC CONTROL ASSEMBLIES

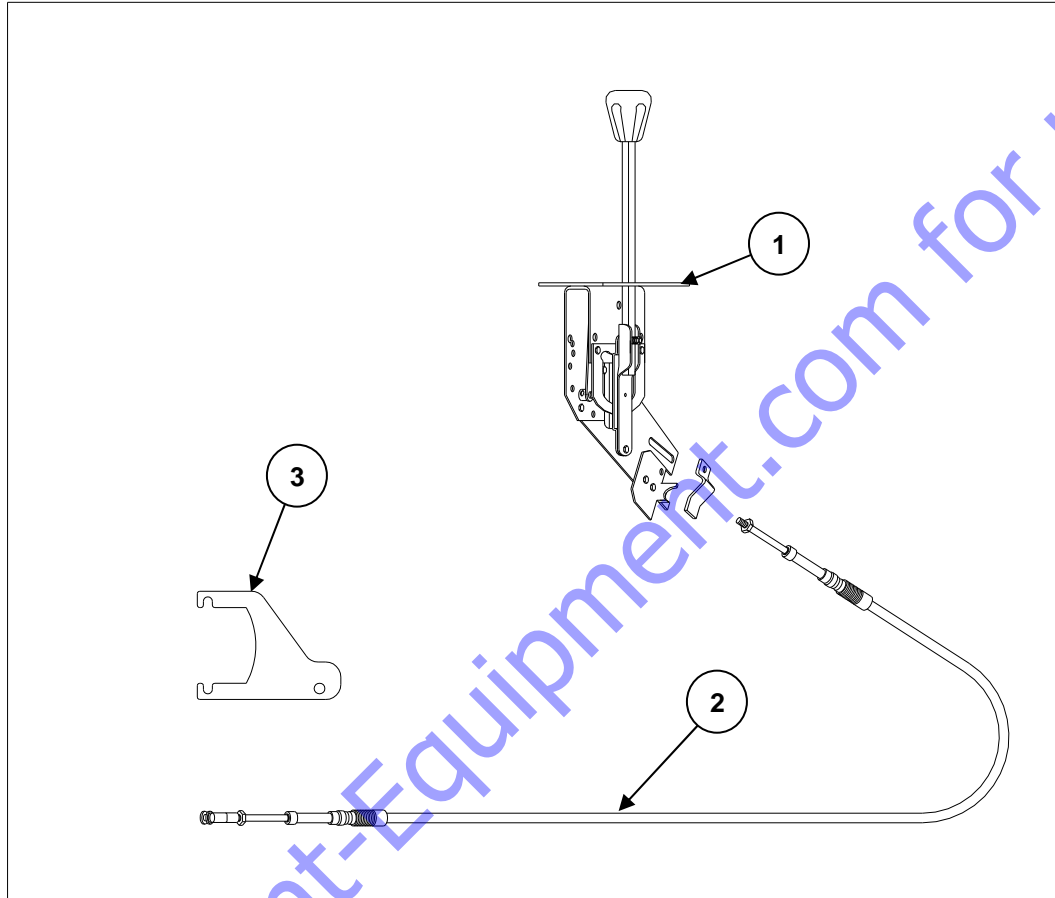

ITEM	PART NUMBER	DESCRIPTION	QUANTITY
1	403035	Hand Control Kit	1
2	309470	Hand Control Cable	1
3	205175	Bracket	1

DASH/STEERING ASSEMBLY

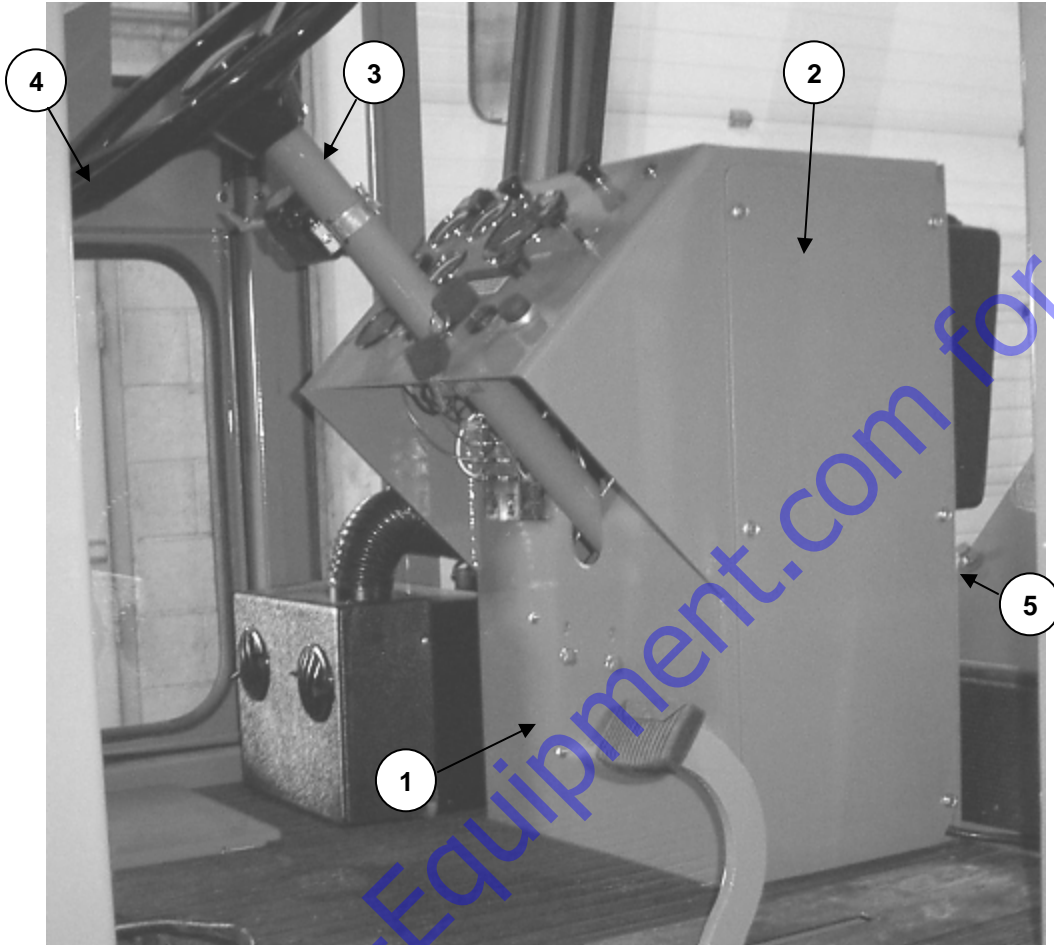

ITEM	PART NUMBER	DESCRIPTION	QUANTITY
1	855168	Dash Housing	1
2	205169	Dash Side Cover	1
3	305945	Steering Column	1
4	S-253-R	Steering Wheel Assembly	1
5	001665	Dash Back Cover	1

GAUGES AND SENDERS

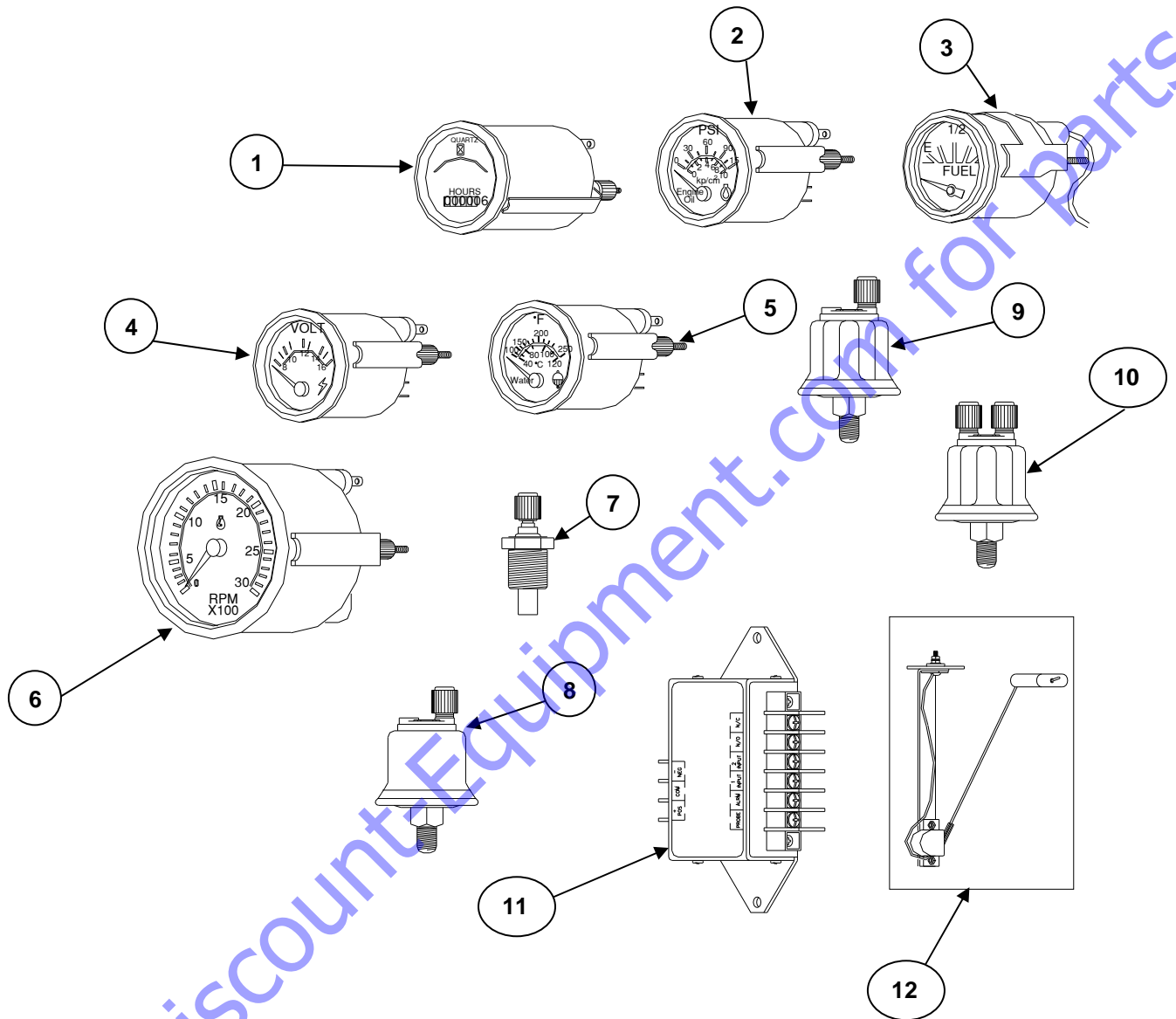

Go to DiscountEquipment.com for parts

GAUGES AND SENDERS

ITEM	PART NUMBER	DESCRIPTION	QUANTITY
1	I-222-HO	Hour Meter	1
2	I-221-R	Oil Pressure Gauge	1
3	I-223-R	Fuel Gauge	1
4	I-220-V	Voltmeter	1
5	I-219-R	Temperature Gauge (Engine)	1
6	I-222-B	Tachometer	1
7	307084	Temperature Sender, CAT 3054C	1
	307088	Temperature Sender, CAT 3054B	1
8	76502	Hour Meter Sending Unit	1
9	IS-221-R	Oil Pressure Sender	1
10	IS-221-WC	Pressure Sender w/ Contact Note: Use w/ warning or shutdown system	1
11	W117	Murphy Switch, Engine shutdown system	1
12	344175	Fuel Sender	1
NS	IS-219-WC	Warning Shutdown Water Sender	1

WINDSHIELD WIPERS & WASHER

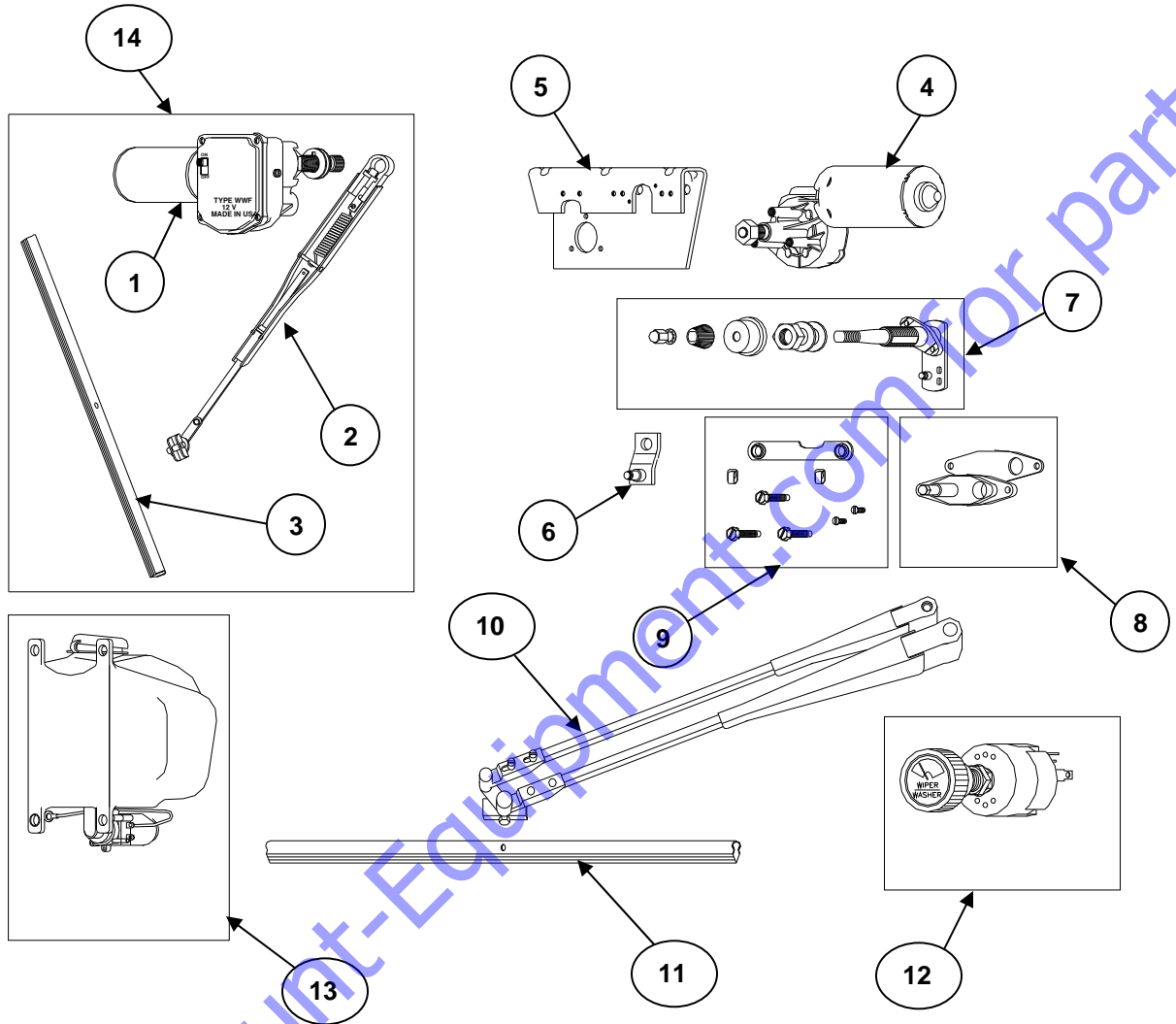

WINDSHIELD WIPERS & WASHER

ITEM	PART NUMBER	DESCRIPTION	QUANTITY
1	1-182-54MO	Wiper Motor	1
2	LE581022-1	Drive Arm	1
3	2-615-2218 2-615-2214	18" Blade (Canopy Windshield) 14" Blade (Rear)	1
4	2-615-15	Wiper Motor	1
5	BK721005	Wiper Motor Mount	1
6	2-615-19	Wiper Drive Arm (Tapered Motor Shaft)	1
7	2-615-60	Wiper Shaft & Arm Assembly	1
8	2-615-17	Pantograph Adapter & Gasket	1
9	721014	Link & Bolt Kit (Includes Bolts, Washers, & Clips)	1
10	2-615-24	Pantograph Drive Arm	1
11	2-615-2226	26" Blade	1
12	2-686-67	Two Speed Wiper Switch	1
13	66-01 66-01A	Washer Pump & Reservoir Washer Kit (Includes Tubing & Hardware)	1 1
14	1-182-54 1-182-54R	Wiper Kit – Canopy Windshield (Motor, Blade, Arm) Wiper Kit – Rear (Motor, Blade, Arm)	1 1

MISC. SWITCHES, FUSES, ETC.

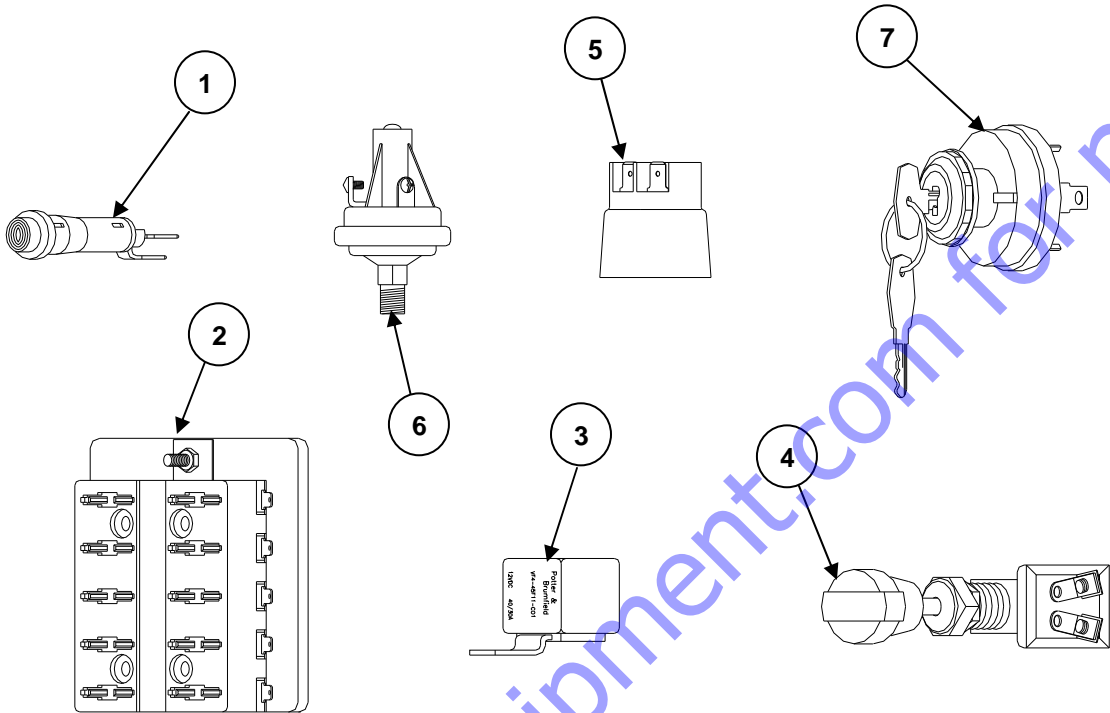

Go to Discount-Equipment.com for parts

MISC. SWITCHES, FUSES, ETC.

ITEM	PART NUMBER	DESCRIPTION	QUANTITY
1	PBL-12	Warning Light	1
2	46050-12	Fuse Block (12 Fuse Capacity)	1
	46050-10	Fuse Block (10 Fuse Capacity)	1
3	WH4411201	Relay – Air Conditioning Shutoff	1
4	23836	Universal Accessory Switch	1
5	X770050	Air Restrictor Sender (Air Cleaner Ind.)	1
6	76052	Pressure Switch (Air Conditioner Shutoff)	1
7	307044	Ignition Switch	1
	307045	Key (Pair)	1
NS	307235	Push Button Switch for Preheat	1

Go to Discount-Equipment.com for parts

LIGHTS – HORNS

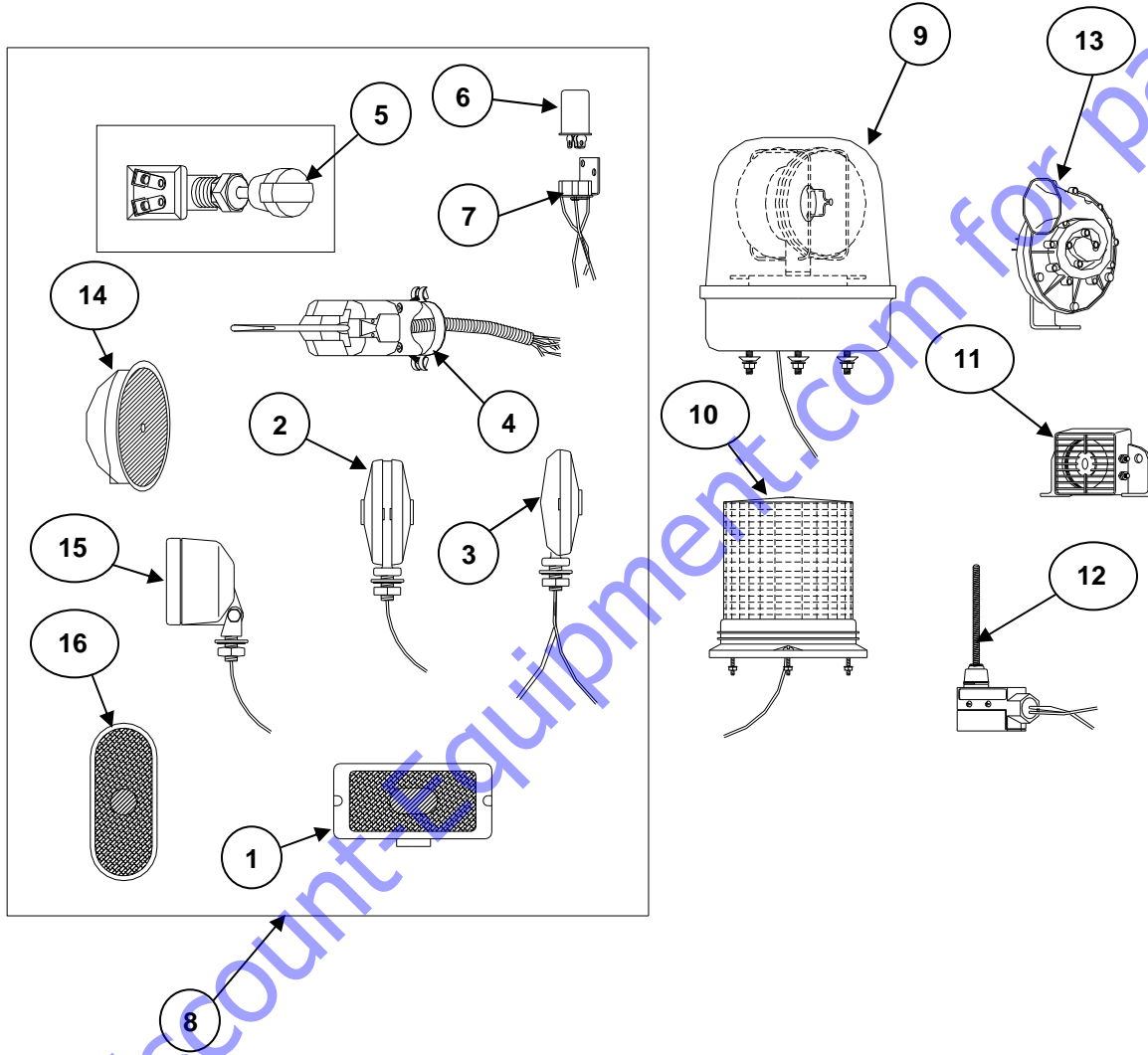

LIGHTS - HORNS

ITEM	PART NUMBER	DESCRIPTION	QUANTITY
1	9-50004-SBA	Driving Light	A/R
2	4-75001	Turn Signal	2
3	6-70001	Stop/Turn Signal	2
4	16-35800	Turn Signal Switch	1
5	23836	Universal Accessory Switch	1
6	550	Flasher	1
7	550FH	Flasher Socket	1
8	LG-100-SBA	Light Group Kit w/ 950004-SBA Driving Lights	See Note
9	7-40004	Amber Beacon	A/R
10	3614A	Amber Strobe Light	A/R
11	RH-250	Reverse Alarm	1
12	LDA-50-1R	Reverse Alarm Switch	1
13	4-302	Traffic Horn	1
14	307031	Flush Mount Tail/Brake Lights	2
15	108-00-132	Work Light	A/R
16	307228	Back Up Light	2

Note: Light Group Kit, Part Number LG-100-SBA, contains all signals, switches, lights, and wiring harness required for field installation.

HEATER/DEFROSTER SYSTEM

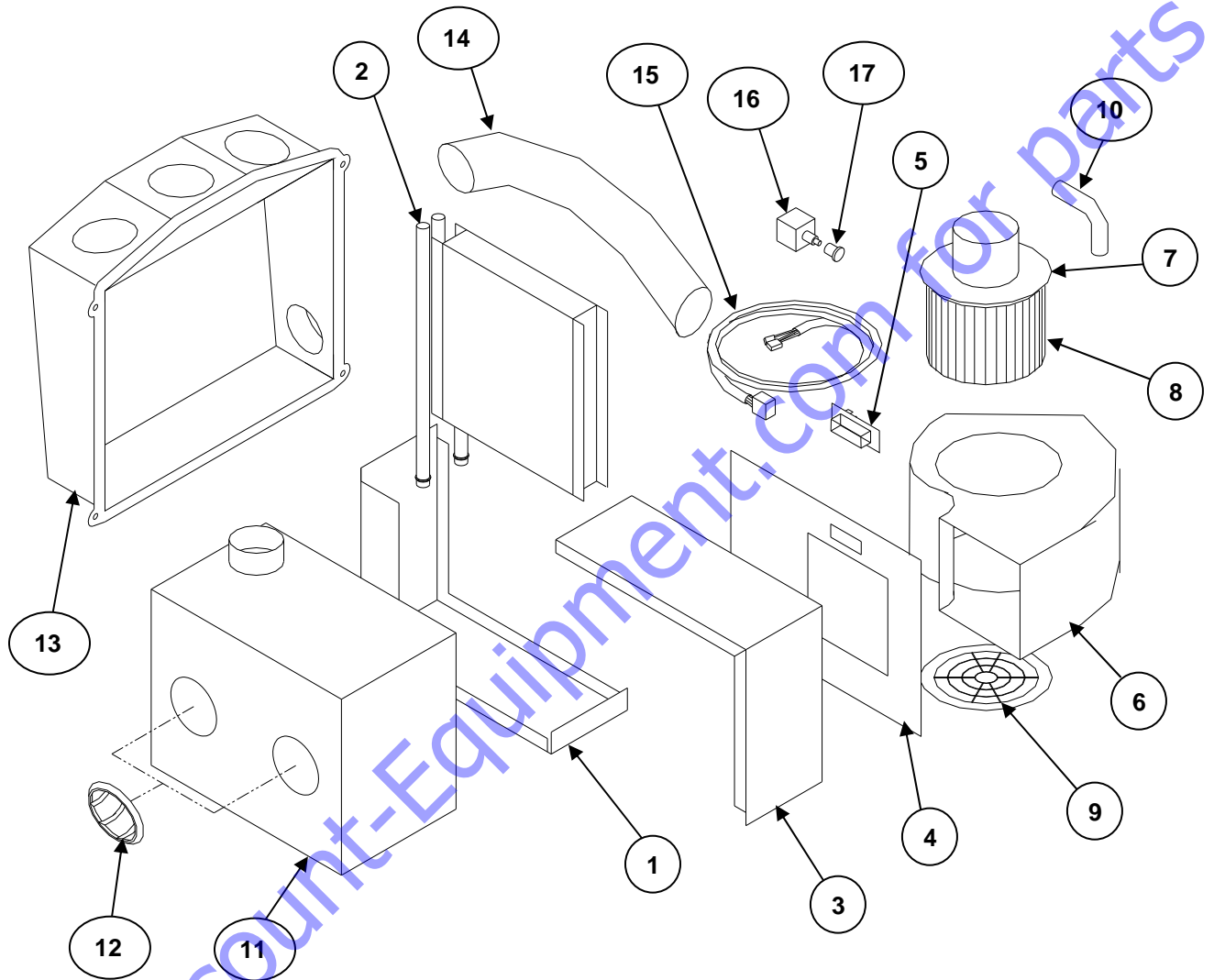

HEATER/DEFROSTER SYSTEM

ITEM	PART NUMBER	DESCRIPTION	QUANTITY
1	403153	Case, Bottom/Side	1
2	403154	Coil	1
3	403155	Cast, Top/Side	1
4	403156	Panel, Blower	1
5	403157	Resistor, 3-Speed	1
6	403158	Housing, Blower	1
7	403159	Motor, CCW	1
8	403160	Wheel, Blower	1
9	403161	Ring, Venturi	1
10	403162	Hose, Vent Motor Blower	1
11	Call	Plenum, Heater	1
12	403164	Louver, 3" Round	1
13	403193	Plenum, Defrost	1
14	403166	Hose – Flex, Wire, Metal, 2.5" Dia.	1
15	403167	Wire Harness – Heater	1
16	403168	Switch, 4 Position Rot.	1
17	403169	Knob – Rotary Switch	1
KIT	Call	Heater/Defroster Kit, CAT 3054B & 3054C	1

AIR CONDITIONING SYSTEM

Features:

- 255 CFM
- Heavy Duty Powder Coated Finish all steel case.
- Low Profile for maximum headroom.
- Filtered, recirculated air.

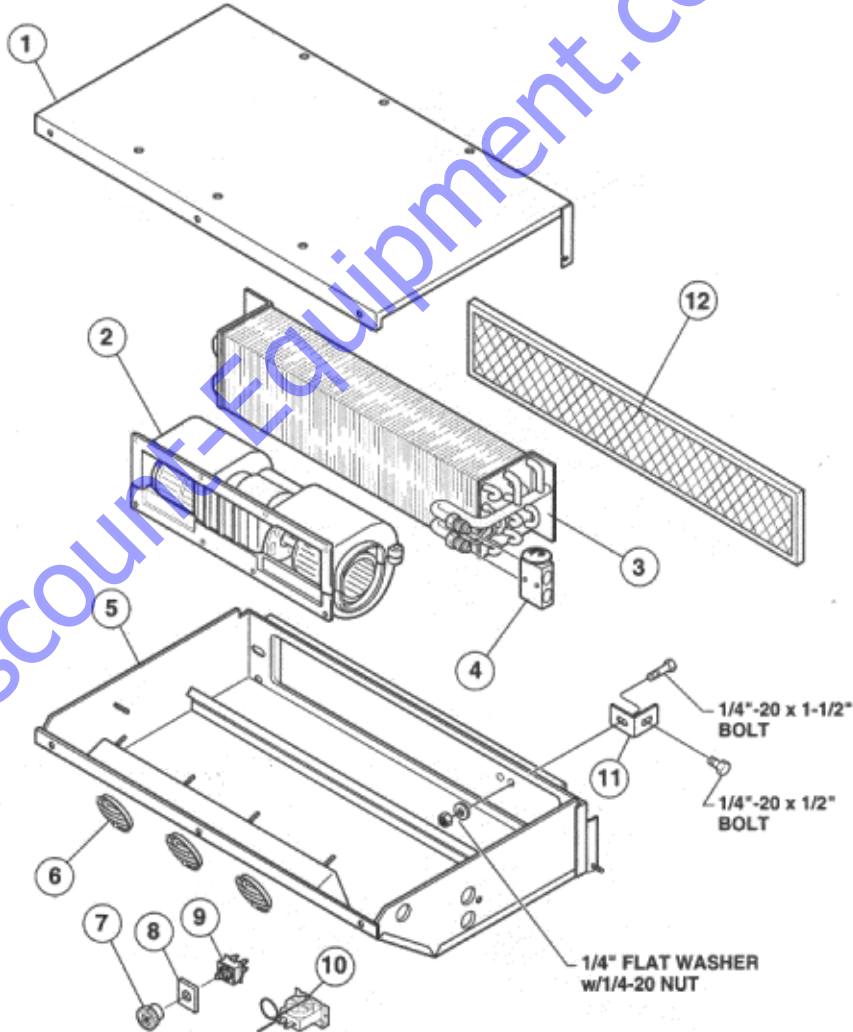
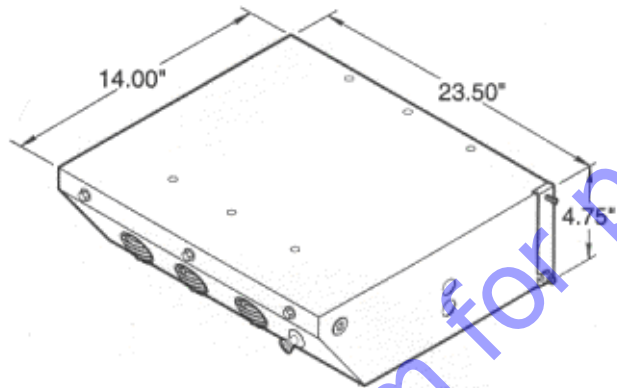

AIR CONDITIONING SYSTEM

ITEM	PART NUMBER	DESCRIPTION	QUANTITY
1	403184	Cover, Evaporator	1
2	403180	Blower Assembly	1
3	403175	Coil, Evaporator	1
4	403174	Valve, Exp., Block, R134a	1
5	403183	Housing, Evaporator	1
6	403164	Louver, 3" Round	1
7	403177	Knob, Fan	1
8	403181	Decal, Fan	1
9	403173	Switch, Rotary	1
10	403176	Thermostat	1
11	403187	Bracket, Mounting, Exp. Valve	1
12	403178	Filter	1
NS	403182	TSTAT Knob	1
NS	403185	Binary Switch	1

Go to Discount-Equipment.com for parts

ENGINES AND RELATED PARTS

Go to Discount-Equipment.com for parts

3054B ENGINE AND RELATED PARTS

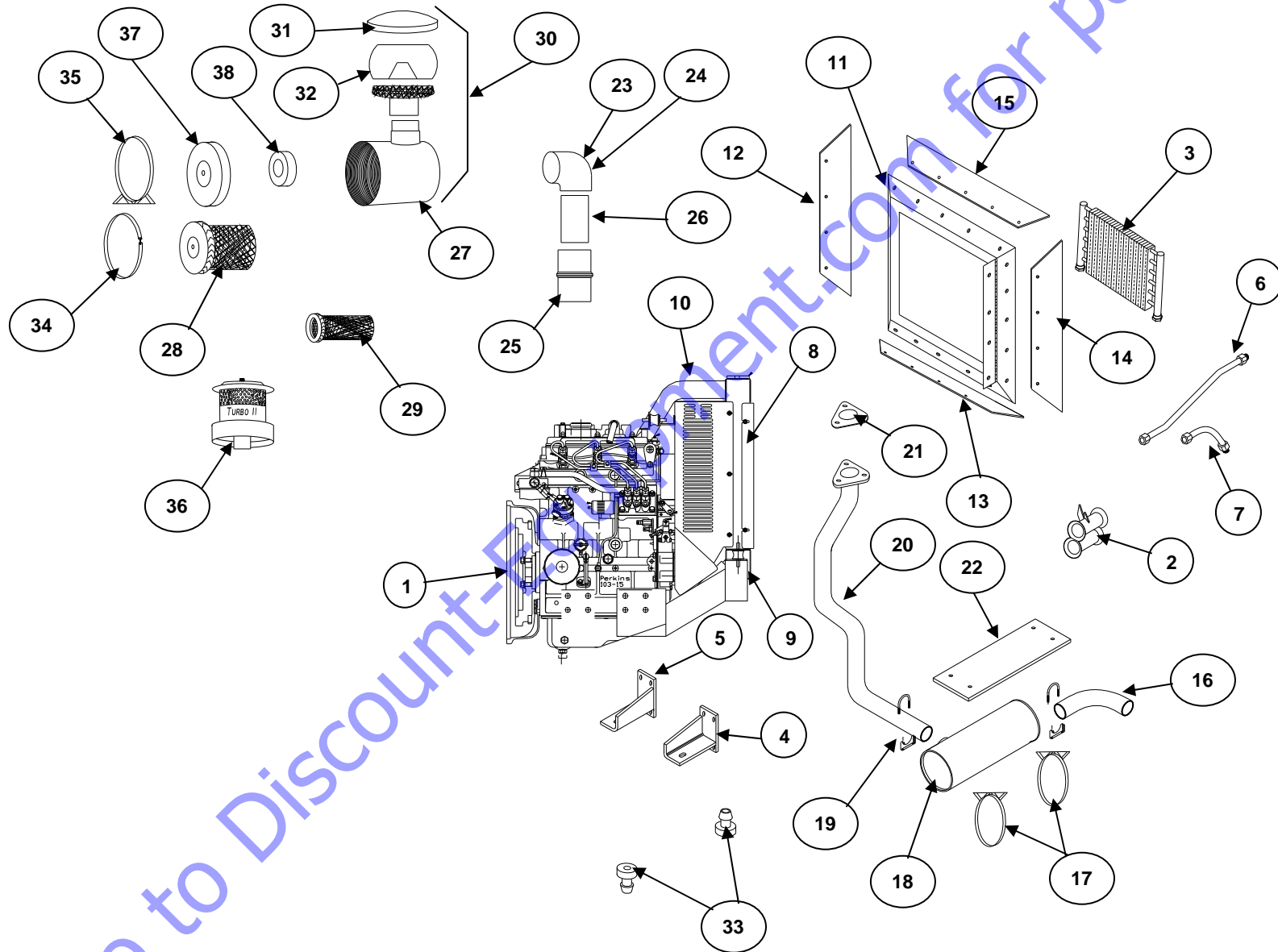

Go to Discount-Parts.com for parts

3054B ENGINE AND RELATED PARTS

ITEM	PART NUMBER	DESCRIPTION	QUANTITY
1	344062	CAT 3054B Diesel Engine	1
2	852045	Oil Cooler Sleeve	1
3	305766	Oil Cooler	1
4	852043	Right Rear Motor Mount (front of broom)	1
5	852042	Left Rear Motor Mount (front of broom)	1
6	852051	Oil Cooler Tube, 23 1/2"	1
7	852052	Oil Cooler Tube, 6 1/2"	1
8	163-1934	Radiator Assembly	1
9	344506	Lower Radiator Hose	1
10	344505	Upper Radiator Hose	1
11	852075	Oil Cooler Mount	1
12	203193	Right Side Oil Cooler Seal	1
13	203190	Lower Seal (Rubber)	1
14	203192	Left Side Oil Cooler Seal	1
15	203191	Upper Seal (Rubber)	1
16	344040	Tail Pipe	1
17	203123	Muffler Clamp	2
18	JE-705-B	Muffler	1
19	JE-758-B	Head Pipe Clamp	2
20	853605	Exhaust Pipe	1
21	344031	Exhaust Gasket	1
22	203105	Exhaust Heat Shield	1
23	AC-760-R	Rubber Elbow, 3" x 3"	2
24	AC-760-B	Rubber, 3.5" x 3"	1
25	304061	Rubber Hump Hose, 3" x 3"	1
26	AC-763-R	Connecting Tube, Short	1
27	DE-770-R	Air Cleaner (Dual Element)	1
28	P182059	Service Element	1
29	P119410	Safety Element	1
30	PC-710-B	Precleaner, 4"	1
31	PC-765-R	Precleaner, Top	1
32	PC-711-R	Precleaner Bowl	1
33	304095	Engine Isolator Kit	4
34	P003951	Clamp	1
35	AC-764-R	Strap	2
36	TT-771-R	Turbo II Precleaner	1
37	P103113	Cup	1
38	P102980	Air Cleaner Baffle	1
NS	344507	CAT Fan	1
NS	344504	Fan Belt	1
NS	304027	Compressor Belt, A/C Only	1
NS	344079	Fuel Filter	1
NS	344078	Oil Filter	1

3054C ENGINE AND RELATED PARTS

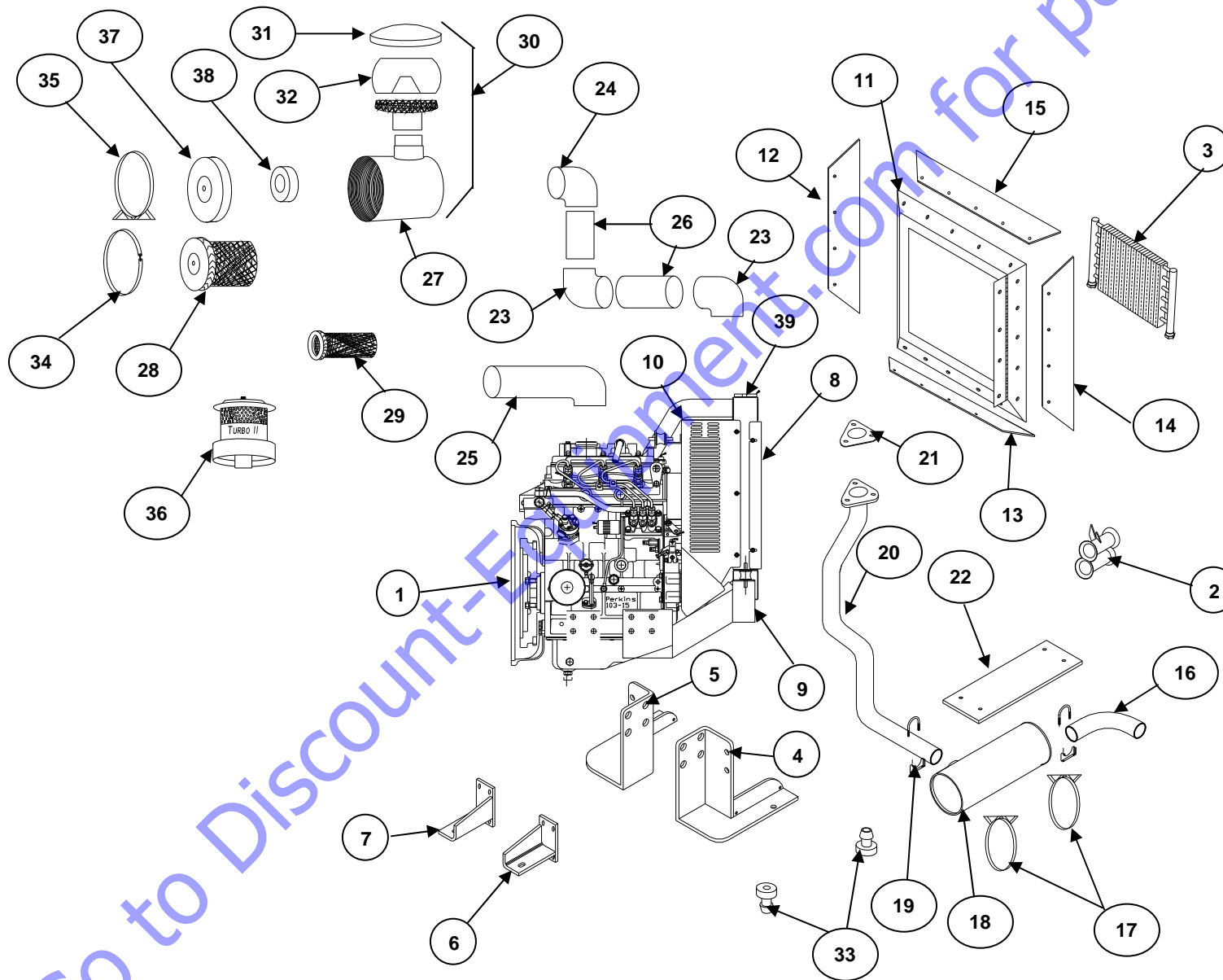

Go to Discount-Element.com for parts

3054C ENGINE AND RELATED PARTS

ITEM	PART NUMBER	DESCRIPTION	QUANTITY
1	344062	CAT 3054C Diesel Engine	1
2	852045	Oil Cooler Hose Guide Sleeve	1
3	305767	Oil Cooler	1
4	203600	Right Front Motor Mount	1
5	203601	Left Front Motor Mount	1
6	852042	Right Rear Motor Mount	1
7	852043	Left Rear Motor Mount	1
8	344508	Radiator Assembly	1
9	344511	Lower Radiator Hose	1
10	344510	Upper Radiator Hose	1
11	853606	Oil Cooler Mount	1
12	203187	Right Side Oil Cooler Seal	1
13	203188	Lower Seal (Rubber)	1
14	203186	Left Side Oil Cooler Seal	1
15	203189	Upper Seal (Rubber)	1
16	344010	Tail Pipe	1
17	203123	Muffler Clamp	2
18	JE-705-B	Muffler	1
19	JE-758-B	Head Pipe Clamp	2
20	853605	Exhaust Pipe	1
21	344031	Exhaust Gasket	1
22	203105	Exhaust Heat Shield	1
23	AC-760-R	Rubber Elbow, 3" x 3"	2
24	AC-760-B	Rubber Elbow, 3.5" x 3"	1
25	304195	Heater Hose	1
26	202152	Connecting Tube, Short	2
27	DE-770-R	Air Cleaner (Dual Element)	1
28	P182059	Service Element	1
29	P119410	Safety Element	1
30	PC-710-B	Precleaner, 4"	1
31	PC-765-R	Precleaner, Top	1
32	PC-711-R	Precleaner Bowl	1
33	304095	Engine Isolator Kit	4
34	P003951	Clamp	1
35	AC-764-R	Strap	2
36	TT-771-R	Turbo II Precleaner	1
37	P103113	Cup	1
38	P102980	Air Cleaner Baffle	1
39	344509	Radiator Cap	1
NS	101-3770	CAT Fan	1
NS	5M8155	Fan Belt	1
NS	304196	Compressor Belt, A/C Only	1
NS	344079	Fuel Filter	1
NS	344078	Oil Filter	1

Go to Discount-Equipment.com for parts

HYDRAULIC DIAGRAMS

Go to Discount-Equipment.com for parts

HYDRAULIC VALVE DIAGRAM

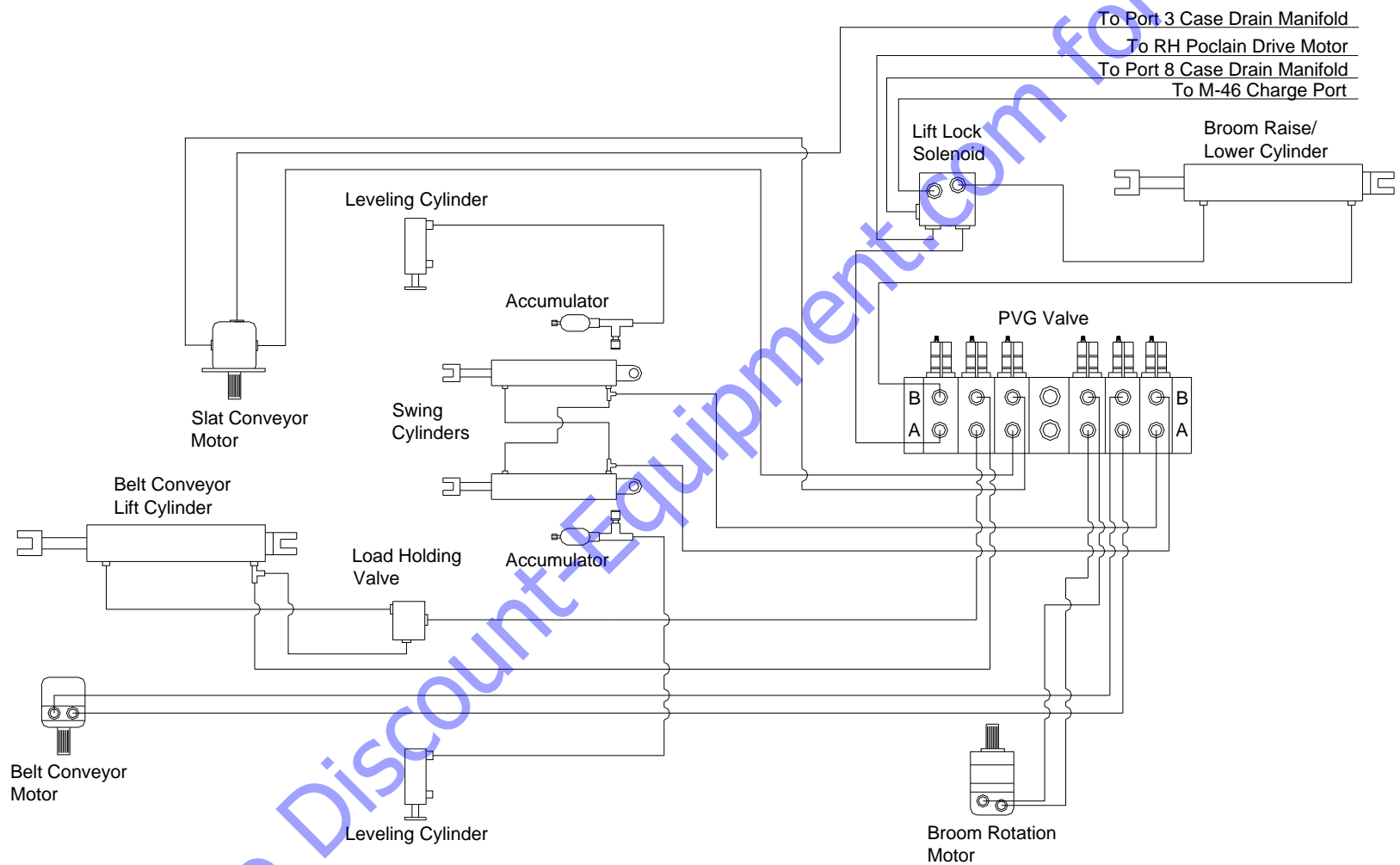

Go to DiscountEquipment.com for parts

HYDRAULIC DIAGRAM

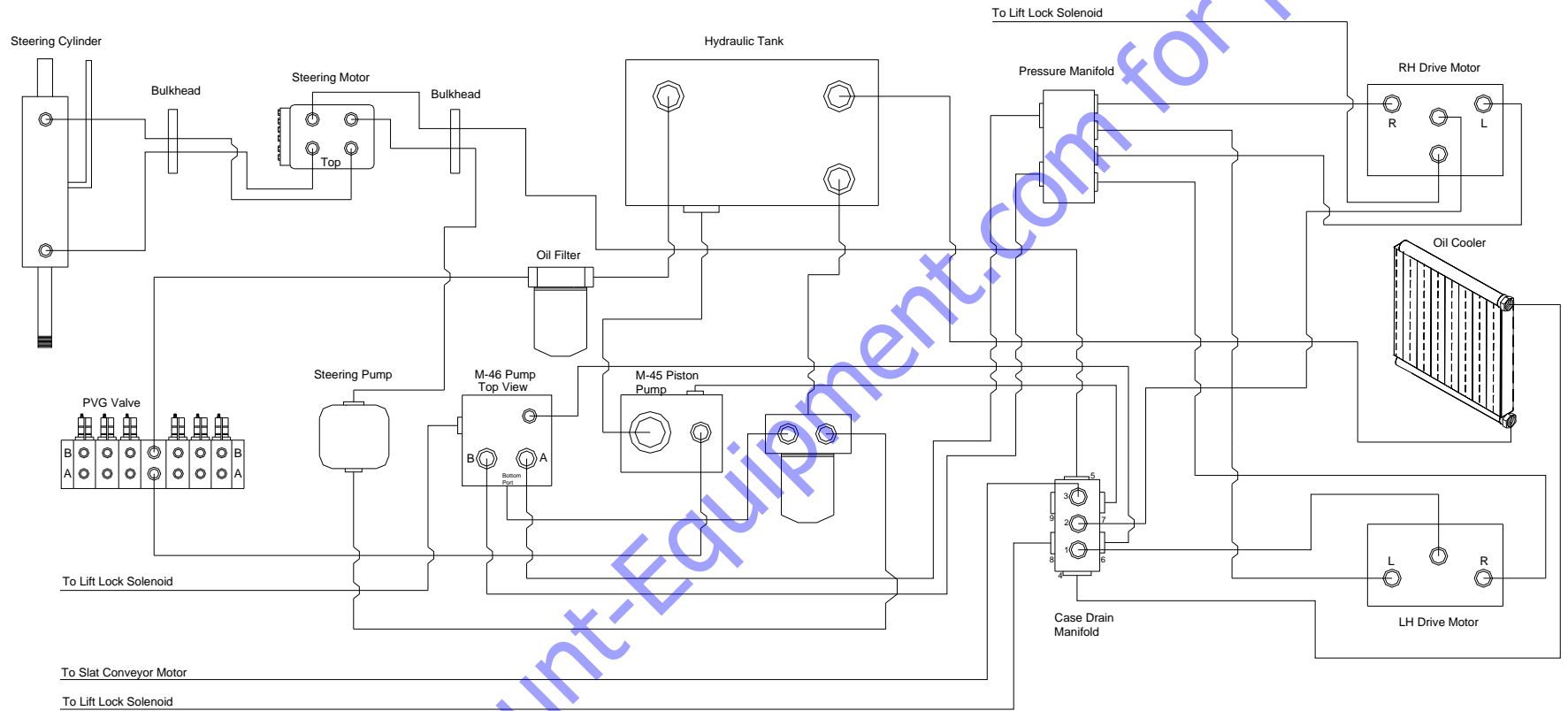

Go to Discount-Equipment.com for parts

Go to Discount-Equipment.com for parts

PARTS INDEX

Go to Discount-Equipment.com for parts

A

Air Conditioning	57-58
Air Conditioning Air Cleaner	41
Air Cleaner – Engine	62, 64
Air Conditioner Compressor Belt	62, 64

B

Belt Conveyor Parts	1-8
Bearings	1, 3
Belt Cleaner	4
Conveyor Belting	1
Conveyor Frame Parts	1-8
Drive Motor	4
Head Pulley	1
Leveling Cylinder	7
Lift Cylinder	6
Lift Cylinder Cross Tube	7
Pivot Cylinders	8
Return Rollers	1
Rubber Deflectors	2, 4, 6
Take-Up Side Plate	3, 5
Wing Pulley	1

Bolster Assembly	25
Brake Control Assembly	26
Brake Light Switch	26
Brake Pedal	26
Broom, Conveyor Controls	43
Brush End Gage	16
Brush Wafers	15
Brush Support Bracket	15

C

Cab Assembly	39-40
Case Drain Manifold	35
CAT Fan	62, 64
Control Box Assembly	42
Conveyor Joystick Control	43
Core Assembly	17
Core Cover Assembly	16
Core Drive Assembly	17
Core Drive Motor	17
Core Frame Assembly	16
Core End Plate	16
Core Frame Support Bearing	12
Core Idle Assembly	16
Core Lift Cylinder	36
Core Side Sheet Rubber	16
Core Support Bearing	16

D, E

Dash Housing	46
Dash Side Cover	46
Decal Kit	18
Doors	39-40
Door Handle	39-40
Dual Locking Valve	36
Engines	61-64
CAT 3054B Engine	61-62
CAT 3054C Engine	63-64
Exhaust System	62, 64

F

Fan Belt	62, 64
Filter, Hydraulic	32
Floor Mat	40
Frame Assembly	15
Front Axle Assembly	27-28
Front Brake Assembly	29-30
Fuel Cap	19
Fuel Gauge Assembly	19
Fuel Hose	19
Fuel Tank Assembly	18
Fuses	51-52

G, H, I, J

Gauges	47-48
Gear Box Assembly	37-38
Heater/Defroster	55-56
Hood Assembly	20
Hood Catch	20
Hood Hinge	20
Hood Linkage	20
Horns	53-54
Hub Assembly	27-28
Hub Cap	27-28
Hydraulic Cap	19
Hydraulic Diagrams	66, 67
Hydraulic Oil Filter	32
Hydraulic Tank Assembly	18
Hydrostat – M-46	31
Hydrostat Control Assembly	45

K, L, M

Lights	53-54
Lug Nut	27-28
Master Cylinder	26
Mirrors	39-40
Motor Mounts	62, 64
Muffler	62, 64

N, O

Oil Cooler	62, 64
Oil Cooler Mount	62, 64
Oil Cooler Seals	62, 64

P, Q

Pressure Manifold	22
Piston Pump, M-45.....	32
PVG Valve.....	33

R

Radiator Assembly	62, 64
Radiator Hoses	62, 64
Rear Drive Motor.....	21
ROPS Brackets	15

S

Screw Conveyor Parts	12-14
Bearings	13, 14
Frame Parts	12-14
Rock Shield	12
Screw Conveyor	12
Screw Conveyor Box.....	12

Seat and Suspension Assembly	42
Seat Belts	42
Seat Base Extension.....	42
Sender Units	47-48

Slat Conveyor Parts	9-11, 13
Bearings	9, 13
Drive Motor.....	11
Frame Parts	9, 10, 13
Head Shaft	9
Load Holding Valve	9
Slat	13
Slat Conveyor Chain	13
Slat Conveyor Frame Parts.....	9-11
Speed Reducer	11
Speed Reducer Bracket.....	10
Speed Reducer Shaft Adapters	11
Sprockets	13
Take Up Frame	9

Steering Column	46
Steering Cylinder.....	27-28
Steering Cylinder Seal Kit	28
Steering Motor.....	23
Steering Motor Mount.....	23

Steering Pump	31
Steering Wheel	46
Suction Manifold	32
Switches.....	51-52

T

Tail Pipe	62, 64
Tie Rod	27-28
Throttle Cable	44
Transmission Control Box.....	44

U-Z

Wheel – 5 or 6 Lug.....	28
Windshield Washer Parts	49-50
Windshield Wiper Parts	49-50

INSTRUCTION MANUAL

DODGE® GRIP-TIGHT ADAPTER MOUNT BALL BEARINGS

⚠ WARNING

To ensure that drive is not unexpectedly started, turn off, lock out, and tag power source before proceeding. Failure to observe these precautions could result in bodily injury.

Shaft & Mounting Surface Inspection

Shaft should be smooth, straight, & within commercial tolerances (Table 1). Remove burrs & align mounting surfaces within 2 degrees.

Assemble Adapter & Bearing

1) If the locknut is loose from the bearing, FIRST place locknut into bearing inner ring groove, THEN insert adapter into bearing bore until it rests against the locknut. Rotate locknut clockwise to engage adapter sleeve.



Pillow Blocks & Tapped Base Housings

NOTE: For Tapped Base (TB) housings drill mounting holes with 1/16" minimum bolt clearance to assist with proper installation.

2) During installation it is best practice is to remove all of the weight from the bearing via slings or jacks. However, if it is difficult to remove all weight then insure the dead weight on the bearing during installation does not exceed the values listed in Table 2.

Series	Maximum Dead Load Per Bearing (lbs)
203-206	60
207-210	65
211-214	70
215-218	75

3) Slide the unit into position onto the shaft. If the unit will not slip onto the shaft, turn locknut counter-clockwise to expand adapter sleeve.

4) Wearing gloves, rotate locknut clockwise, by hand, as tight as possible until adapter sleeve grips and does not spin on the shaft or move axially. If needed, tap on locknut outer diameter while turning locknut to assist with this step. Scribe the line on the locknut above the adapter sleeve slot.

5) Lock bearing to shaft by rotating locknut, with a spanner wrench or brass bar & hammer, clockwise by amount shown in Table 3. NOTE: The use of air chisels is not recommended.

6) Center housing & mounting bolts over mounting holes & tighten bolts to proper torque (Table 4). Tighten locknut setscrew until 3/32" Allen key bends (25 in-lbs).

7) Repeat above steps for mounting 2nd housing. Do not tighten mounting bolts on 2nd housing until second bearing has been completely locked to the shaft. Bolts must fit freely between housing & mounting surface. If the mounting bolts do not fit freely, loosen mounting bolts on both housings & center both units. If the bolts still will not fit freely, remove one unit from the shaft, reposition housing, & reinstall.

Shaft Size (in)	Commercial Shaft Tolerances (in)
Up to 1 1/2"	+0.000" / - 0.002"
1 5/8" - 2 1/2"	+0.000" / - 0.003"
2 11/16" - 3 7/16"	+0.000" / - 0.004"

Series	Shaft Size GT (Normal Duty)	Shaft Size GTM (Medium Duty)	Locknut Rotation
203 - 204	1/2" - 3/4" 17 - 20 mm	---	1/2 Turn
205 - 210	7/8" - 1 3/4" 25 - 45 mm	3/4" - 1 1/2" 20 - 40 mm	2/3 Turn
211 - 218	1 15/16" - 2 15/16" 50 - 75 mm	1 11/16" - 3 1/2" 45 - 85 mm	1 Turn

Metal Housings		Non-Metallic Polymer Housing			
All Housing Types		Pillow Block, 2 & 4 Bolt Flange, Flange Bracket		Tapped Base	
Bolt Size (in)	Dry Torque (in lbs)	Bolt Size (in)	Dry Torque (18-8 Stainless) (in lbs)	Bolt Size (in)	Dry Torque (18-8 Stainless) (in lbs)
3/8	240	3/8	225	3/8	175
7/16	384	7/16	350	7/16	350
1/2	600	1/2	500	1/2	400
5/8	1200	9/16	650		
3/4	2100	5/8	1000		
7/8	2040				



⚠ WARNING

Because of the possible danger to person(s) or property from accidents which may result from the improper use of products, it is important that the correct procedure be followed. Products must be used in accordance with the engineering information specified in the catalog. Proper installation, maintenance, and operating procedures must be observed. The instructions in the instruction manuals must be followed. Inspections should be made as necessary to ensure safe operation under prevailing conditions. Proper guards and other suitable safety devices or procedures as may be desirable or as may be specified in safety codes should be provided, and are neither provided by Baldor Electric Company nor are the responsibility of Baldor Electric Company. This unit and its associated equipment must be installed, adjusted, and maintained by qualified personnel who are familiar with the construction and operation of all equipment in the system and potential hazards involved. When risk to persons or property may be involved, a holding device or shear bars must be an integral part of the driven equipment.

All Flange Housings

WARNING: Special attention to the installation procedure for flange bearings is necessary to maintain the proper internal clearance & achieve maximum life. The installation of the first flange differs from the installation of the second flange.

(See step 1 **Assemble Adapter & Bearing** page 1)

2) During installation it is best practice is to remove all of the weight from the bearing via slings or jacks. However, if it is difficult to remove all weight then insure the dead weight on the bearing during installation does not exceed the values listed in Table 2.

3) Slide the FIRST unit into position onto the shaft. If the bearing will not slip onto the shaft or more axially, turn locknut counter clockwise to expand adapter sleeve.

4) (Using gloves) rotate locknut clockwise by hand until it is tight & adapter sleeve grips & does not spin on the shaft. This is the starting point. Scribe a line on the locknut above the adapter sleeve slot.

(If needed, tap on locknut outer diameter while turning locknut to assist with this step.)

5) Lock bearing to shaft by rotating locknut, with a spanner wrench or brass bar & hammer, clockwise by amount shown in Table 2.
NOTE: The use of air chisels is not recommended.

6) Tighten locknut setscrew until 3/32" Allen key bends (or 25 in-lbs). Tighten housing bolts to proper torque (Table 3).

7) Slide the **SECOND** flange onto the shaft and hand tighten as in step 4 but leave 1/16" minimum gap between the flange housing & the mounting surface. See picture to the right.

8) It is important to note that the 1/16" minimum gap between the flange housing and the mounting surface must be maintained while getting the bearing hand tight to the shaft. Wearing gloves, rotate the locknut clockwise, by hand, until adapter sleeve grips and does not spin or move axially on the shaft. If needed, tap on the locknut outer diameter while turning the locknut to assist with this step. At this point you should have difficulty in rotating the locknut by hand and you should not be able to move the bearing axially along the shaft by hand. If the bearing can be moved axially along the shaft by hand then continue rotating the nut gradually until it grips the shaft. Scribe a line on the locknut above the adapter sleeve slot.

9) Insert housing bolts & pull the housing flush with mounting surface by alternately tightening the bolts to the proper torque (Table 4).

10) Lock bearing to shaft by rotating locknut, with a spanner wrench or drift pin & hammer, clockwise by amount shown in Table 3. Tighten locknut setscrew until 3/32" Allen key bends (25 in-lbs).

11) Rotate the shaft by hand, no binding or excessive drag should be felt. If excessive drag is felt, loosen the second bearing & reinstall starting at step 8.

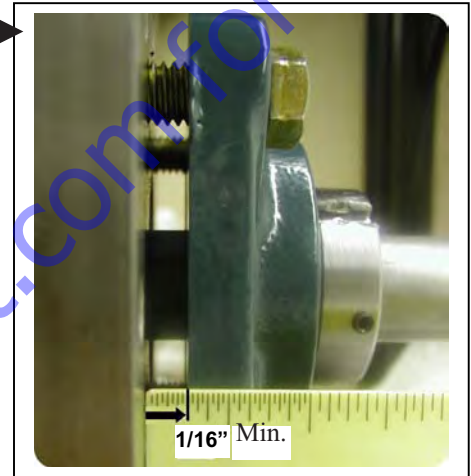

Dismounting All Units

1) Remove all weight from the bearing via slings or jacks & secure the shaft from rotation.

2) **LOOSEN THE HOUSING MOUNTING BOLTS & COMPLETELY REMOVE SETSCREW IN THE LOCKNUT.**

3) Rotate locknut counter clockwise with spanner wrench or drift pin & hammer until bearing is free.

Lubrication: (Use compatible Lithium base NGLI #2 grease & see Table 5)

The Dodge Grip-Tight bearing has been greased from the factory & is shaft ready. When re-lubricating slowly add grease until fresh grease is seen purging past the seal. In the higher speed ranges, excess grease may cause temporary bearing overheating. The amount of grease a bearing will take for a specific high speed application is best determined by experience. When establishing a re-lubrication schedule, note that a small amount of grease at frequent intervals is preferred to a large amount of grease at infrequent intervals. Lubrication recommendations are intended for standard products applied in general operating conditions. For modified products, high temperature applications, and other anomalous applications contact product engineering at 864-284-5700

Table 5 - Suggested Lubrication Intervals in Weeks

Hours Run Per Day	RPM							
	1 to 250 RPM	251 to 500 RPM	501 to 750 RPM	751 to 1000 RPM	1001 to 1500 RPM	1501 to 2000 RPM	2001 to 2500 RPM	2500 to Max RPM
8	12	12	10	7	5	4	3	3
16	12	7	5	4	2	2	1	1
24	10	5	3	2	1	1	1	1

www.baldor.com www.ptplace.com www.dodge-pt.com www.reliance.com



Baldor Electric Company Headquarters

P.O. Box 2400, Fort Smith, AR 72902-2400 U.S.A., Ph: (1) 479.648.5792, Fax (1) 479.648.5792, International Fax (1) 479.648.5895

Baldor - DODGE/Reliance

6040 Ponders Court, Greenville, SC 29615-4617 U.S.A., Ph: (1) 864.297.4800, FAX: (1) 864.281.2433

5/07 Copyright © 2007 Baldor Electric Company All Rights Reserved. Printed in USA.

This material is not intended to provide operational instructions. Appropriate instruction manuals and precautions should be studied prior to installation, operation or maintenance of equipment.



IM499312

PARTS FINDER

**Search Website
by Part Number**



**Search Manual
Library For Parts
Manual & Lookup Part
Numbers – Purchase
or Request Quote**

**Can't Find Part or
Manual? Request Help
by Manufacturer,
Model & Description**

Discount-Equipment.com is your online resource for quality parts & equipment.

Florida: **561-964-4949** Outside Florida TOLL FREE: **877-690-3101**

Need parts?

Click on this link: <http://www.discount-equipment.com/category/5443-parts/> and choose one of the options to help get the right parts and equipment you are looking for. Please have the machine model and serial number available in order to help us get you the correct parts. If you don't find the part on the website or on one of the online manuals, please fill out the request form and one of our experienced staff members will get back to you with a quote for the right part that your machine needs.

We sell worldwide for the brands: Genie, Terex, JLG, MultiQuip, Mikasa, Essick, Whiteman, Mayco, Toro Stone, Diamond Products, Generac Magnum, Airman, Haulotte, Barreto, Power Blanket, Nifty Lift, Atlas Copco, Chicago Pneumatic, Allmand, Miller Curber, Skyjack, Lull, Skytrak, Tsurumi, Husquvarna Target, Stow, Wacker, Sakai, Mi-T-M, Sullair, Basic, Dynapac, MBW, Weber, Bartell, Bennar Newman, Haulotte, Ditch Runner, Menegotti, Morrison, Contec, Buddy, Crown, Edco, Wyco, Bomag, Laymor, EZ Trench, Bil-Jax, F.S. Curtis, Gehl Pavers, Heli, Honda, ICS/PowerGrit, IHI, Partner, Imer, Clipper, MMD, Koshin, Rice, CH&E, General Equipment, Amida, Coleman, NAC, Gradall, Square Shooter, Kent, Stanley, Tamco, Toku, Hatz, Kohler, Robin, Wisconsin, Northrock, Oztec, Toker TK, Rol-Air, APT, Wylie, Ingersoll Rand / Doosan, Innovatech, Con X, Ammann, Mecalac, Makinex, Smith Surface Prep, Small Line, Wanco, Yanmar