

THE
BARRETO
MODEL 3104CMS
CHIPPER MULCHER SHREDDER
OPERATOR'S MANUAL

3104CMS INTENDED USE

The BARRETO 3104 Chipper Mulcher Shredder (CMS) is designed to chip, shred, and mulch wood, leaves, grass and other such plant materials. The chipper can handle tree limbs up to 4 inches in diameter while the mulcher hopper can handle leafy branches up to 1 inch in diameter and other such soft but bulky plant material.

OPERATOR TRAINING / INSTRUCTIONS

Everyone who operates a CMS or assists the CMS operator needs to know the following aspects of machine operation before operating the CMS. They are important and must be a part of operator training.

Rental companies need to understand and be able to explain and demonstrate all of the machine operations to each rental customer including.

- **KNOW AND UNDERSTAND ALL SAFETY POINTS AND CONSIDERATIONS**
- Check that all guards/covers and safety decals are in place
 - If an engine driven component is exposed or accessible a guard is missing.
- Know how to properly connect the CMS to a towing vehicle
- Know the towing position of the: swivel jack or stand; chipper hopper and rear flap
- Know the operating position of the: swivel jack or stand, chipper hopper and rear flap
- Understand the CMS capabilities and intended use
- Know how to start and stop the engine
- Know how to engage and disengage the clutch
- Understand how to prevent clogs
- Know how to properly lock the chipper disk / mulcher rotor
- Know how to safely clear clogs from the chipper and mulcher hoppers

CMS OWNER CONTACT INFORMATION

THIS CMS BELONGS TO: _____

PHONE NUMBER: _____

PARTS FINDER

**Search Website
by Part Number**



**Search Manual
Library For Parts
Manual & Lookup Part
Numbers – Purchase
or Request Quote**

Search Manuals

Enter your information to help us find the right parts manual for your machine.

* Brand:

* Model:

* Serial:

* Part Number:

SEARCH

**Can't Find Part or
Manual? Request Help
by Manufacturer,
Model & Description**

Parts Order Form

Please fill in the following information to help us find the right part for your machine.

Manufacturer:	<input type="text"/>
Model:	<input type="text"/>
Description:	<input type="text"/>
Part Number:	<input type="text"/>
Quantity:	<input type="text"/>
Notes:	<input type="text"/>

Submit

Discount-Equipment.com is your online resource for quality parts & equipment.

Florida: **561-964-4949** Outside Florida TOLL FREE: **877-690-3101**

Need parts?

Click on this link: <http://www.discount-equipment.com/category/5443-parts/> and choose one of the options to help get the right parts and equipment you are looking for. Please have the machine model and serial number available in order to help us get you the correct parts. If you don't find the part on the website or on one of the online manuals, please fill out the request form and one of our experienced staff members will get back to you with a quote for the right part that your machine needs.

We sell worldwide for the brands: Genie, Terex, JLG, MultiQuip, Mikasa, Essick, Whiteman, Mayco, Toro Stone, Diamond Products, Generac Magnum, Airman, Haulotte, Barreto, Power Blanket, Nifty Lift, Atlas Copco, Chicago Pneumatic, Allmand, Miller Curber, Skyjack, Lull, Skytrak, Tsurumi, Husquvarna Target, Stow, Wacker, Sakai, Mi-T-M, Sullair, Basic, Dynapac, MBW, Weber, Bartell, Bennar Newman, Haulotte, Ditch Runner, Menegotti, Morrison, Contec, Buddy, Crown, Edco, Wyco, Bomag, Laymor, EZ Trench, Bil-Jax, F.S. Curtis, Gehl Pavers, Heli, Honda, ICS/PowerGrit, IHI, Partner, Imer, Clipper, MMD, Koshin, Rice, CH&E, General Equipment, Amida, Coleman, NAC, Gradall, Square Shooter, Kent, Stanley, Tamco, Toku, Hatz, Kohler, Robin, Wisconsin, Northrock, Oztec, Toker TK, Rol-Air, APT, Wylie, Ingersoll Rand / Doosan, Innovatech, Con X, Ammann, Mecalac, Makinex, Smith Surface Prep, Small Line, Wanco, Yanmar

TABLE OF CONTENTS

3104CMS INTENDED USE.....	1
OPERATOR TRAINING / INSTRUCTIONS.....	1
TABLE OF CONTENTS	2
SAFETY MESSAGES	2
SAFETY INSTRUCTIONS OVERVIEW.....	3
BATTERY SAFETY INSTRUCTIONS.....	5
TOWING INSTRUCTIONS	6
OPERATORS WORKING AREA.....	8
SETTING UP THE CMS	8
STARTING AND STOPPING THE ENGINE.....	9
ENGAGING AND DISENGAGING THE CLUTCH.....	9
FEEDING MATERIAL	10
CLEARING DEBRIS CLOGS FROM THE CMS	11
LOCKOUT PROCEDURE	11
LUBRICATION / GREASE REQUIREMENTS	13
CMS OPERATORS TROUBLE SHOOTING GUIDE.....	14

SAFETY MESSAGES

This section covers the method used to announce safety messages. Safety messages appear as appropriate in this manual and on decals affixed to the machine where a hazard may occur if procedure or instructions are not followed correctly and completely.



This is the ISO general warning sign; it has been adapted for black and white printing.
Standard No.: 7010:2011

It is used in conjunction with the following signal words to communicate a hazard.

From: ISO 3861-2:2004











- **DANGER:** Indicates an imminently hazardous situation which, if not avoided, will result in death or serious injury.
- **WARNING:** Indicates a potentially hazardous situation which, if not avoided, could result in death or serious injury.
- **CAUTION:** Indicates a potentially hazardous situation which, if not avoided, could result in minor or moderate injury.

Study ALL decals on the CMS before operating the CMS.

ALWAYS USE COMMON SENSE AND THINK SAFETY FIRST!

SAFETY INSTRUCTIONS OVERVIEW

READ ALL SAFETY AND OPERATING INSTRUCTIONS BEFORE OPERATING!
ANYONE ASSISTING CMS OPERATION IS ALSO CONSIDERED AN OPERATOR.
FOLLOW ALL SAFETY INSTRUCTIONS WHILE OPERATING!
MAKE SURE OTHERS FOLLOW THEM TOO!

-  **DANGER:** Stay clear of moving parts. Belts, chipper blades, mulching hammers and other moving parts can cut off fingers, arms, legs and other body parts. Contact with moving parts while the machine is operating will cause death or serious injury.
-  **DANGER:** Never reach into the CMS, while running or capable of running. Reaching into the CMS will result in death or serious injury.
-  **DANGER:** Only operate outdoors and avoid breathing engine exhaust fumes. Engine exhaust contains carbon monoxide gas which is toxic. Breathing it can cause unconsciousness and death.
-  **DANGER:** Never permit anyone to ride on the CMS while towing. The CMS is NOT intended to carry passengers; carrying passengers on the CMS will result in death or serious injury.
-  **DANGER:** Never operate the CMS with any guards, flaps or screens removed. If a moving part is readily accessible a guard is not present and must be installed before operating.
-  **DANGER:** Do not leave the CMS unattended with the engine running or the key accessible. Always turn off the engine and remove the key when not using the CMS.
-  **DANGER:** Do not operate the CMS under the influence of: alcohol; illicit drugs; prescription drugs that warn against driving or operating machinery, or any substance that will impair judgment or physical coordination.
-  **DANGER:** Never permit a minor (under 18) to operate the CMS. Never permit anyone with a mental or physical impairment that will adversely affect safe CMS operation to operate the CMS.
-  **WARNING:** Wear appropriate personal protective equipment, safety glasses, ear plugs hard hat, gloves, and boots. DO NOT wear loose clothing, jewelry, long hair or anything that may get caught in a moving part.
-  **WARNING:** Do not stand or step on the CMS. There is no place on the CMS for someone to stand or step. Standing or stepping on the CMS will put you in close proximity to dangerous moving parts and extremely hot engine components.
-  **WARNING:** Stay clear of the back of the CMS while in operation. High speed debris exits the back of the CMS.

SAFETY INSTRUCTIONS OVERVIEW CONTINUED



WARNING: Operate the CMS on level ground and use tire chocks. If operating on a grade is unavoidable, connect the CMS to a towing vehicle, chock the CMS and towing vehicle tires, engage the towing vehicle parking brake and position the towing vehicle to prevent a runaway. Do not leave the CMS unattended with the engine running.



WARNING: Park and store the CMS on level ground, use tire chocks to prevent the CMS from rolling. The CMS is not equipped with brakes and may roll on an incline.

We recommend having a fire extinguisher capable of extinguishing class A, B & C fires in the operating area.



WARNING: Do not operate the CMS near flames or sparks. Fuel, fuel fumes and plant debris can catch fire.



WARNING: Do not operate the CMS near any source of flammable dust or vapor. Sparks from the engine can cause a fire or explosion in a flammable atmosphere.



WARNING: Shut off engine and allow it to cool before refueling. Sparks and heat from the engine may ignite fuel.

Keep others away from the CMS while operating. Select job sites free from bystanders. If the job site is near a road or a pedestrian pathway and cannot be moved, warn and divert both motorized and pedestrian traffic. As appropriate and legal, use traffic flag personnel, signs, cones and lighting devices to ensure safety. Diverting traffic and working in congested public areas may require permits or other such legal considerations. It is your responsibility to know and follow all laws applicable to where you are working.

IF AT ANY POINT AND FOR ANY REASON, YOU DO NOT FEEL CONFIDENT ABOUT OPERATING THE CMS OR RECOGNIZE THAT YOU CANNOT SAFELY OPERATE THE CMS, STOP IMMEDIATELY. IF CONFIDENT TO DO SO, DISENGAGE THE CLUTCH AND TURN OFF THE ENGINE. CONTACT THE CMS OWNER.

Emergency & Medical Contacts:

USA & CANADA: Emergency dial: **911**

USA & CANADA: American Association of Poison Control Centers: **1-800-222-1222**

Outside the USA & Canada (Please fill in the appropriate number)

National Emergency number: _____

Poison Control Center: _____

Other: _____

BATTERY SAFETY INSTRUCTIONS

Only trained and qualified personnel should perform maintenance or repairs of the CMS or the battery. With the exception of following the greasing/lubrication requirements and checking/adding engine oil, maintenance is the responsibility of the owner and should not be performed by the operator.



WARNING: The battery contains sulfuric acid that can cause blindness and severe burns. Avoid contact with eyes, skin and clothing.



WARNING: Battery fumes are flammable and explosive. Avoid exposing the battery to sparks and flames. Sparks can be created near the battery when handling battery cables or jumper cables.



WARNING: The battery, posts, terminals, and related accessories contain lead and lead compounds, chemicals known to the State of California to cause cancer and reproductive harm.



WARNING: Wear appropriate personal protective equipment when handling the battery. Shield entire face, especially your eyes, wear rubber gloves and a rubber apron to reduce the risk of acid burns. Battery caps must be tightly in place if the battery has removable caps.

First Aid Measures from Material Safety Data Sheet, for sulfuric acid: ScienceLab.com

- **Eye Contact:** Check for and remove contact lenses. Immediately flush eyes with plenty of water for at least 15 minutes. Cold water may be used. Get medical attention immediately.
- **Skin Contact:** Immediately flush skin with plenty of water for 15 minutes while removing contaminated clothing and shoes. Cover irritated skin with an emollient. Cold water may be used. Wash clothing before reuse. Thoroughly clean shoes before reuse. Get medical attention immediately.
- **Serious Skin Contact:** Wash with a disinfectant soap and cover the contaminated skin with an anti-bacterial cream. Seek immediate medical attention.
- **Inhalation:** If inhaled, remove to fresh air. If not breathing give artificial respiration. If breathing is difficult, give oxygen. Get medical attention immediately.
- **Serious Inhalation:** Evacuate the victim to a safe area as soon as possible. Loosen tight clothing such as a collar, tie, belt, or waistband. If breathing is difficult, administer oxygen. If the victim is not breathing, perform mouth-to-mouth resuscitation. Seek immediate medical attention



WARNING: It may be hazardous to the person providing aid to give mouth-to-mouth resuscitation when the inhaled material is toxic, infectious or corrosive.

- **Ingestion:** DO NOT induce vomiting unless directed to do so by medical personnel. Never give anything by mouth to an unconscious person. Loosen tight clothing such as a collar, tie, belt or waistband. Get medical attention immediately.
- **Serious ingestion:** Not available. Get medical attention immediately.

Emergency & Medical Contacts:

USA & CANADA: Emergency dial **911**

USA & CANADA: American Association of Poison Control Centers: **1-800-222-1222**

Outside the USA & Canada (Please fill in the appropriate number)

National Emergency number: _____

Poison Control Center: _____

Other: _____

TOWING INSTRUCTIONS

While towing the CMS obey all traffic laws and never exceed 45mph (75km/h). The towing vehicle and the CMS must be in legal, road worthy condition which may include registration. Refer to and check the following list before towing.

NOTICE: Move the fuel shutoff lever to the closed position after stopping the engine, especially before towing. Failure to do so could cause fuel to leak into the cylinder and crankcase. Resulting damage will not be covered under warranty.

- Inspect all towing points: hitch/coupler; hitch ball; safety chains and safety chain attachment points on towing vehicle and CMS tongue. Replace any damaged components before towing.
- Inspect CMS tires for damage and check tire pressure. See tire side wall for correct tire pressure.
- The towing vehicle must be rated to tow trailers in excess of 1500 pounds with a tongue weight in excess of 180 pounds.
- The towing vehicle must be equipped with a hitch ball between 1-7/8" to 2". The hitch ball must be in good condition and be securely fastened to the towing vehicle.
- The towing vehicle must have 2 points, one on either side of the hitch ball to attach the safety chain.
- The safety chain must be securely fastened to the CMS tongue.
- If equipped with lights, connect the wiring adapter on the CMS to the plug on the towing vehicle. Make sure that all lights, on both vehicles work. If NOT equipped with lights do not tow at night or other low light conditions.
- Securely fasten the coupler to the hitch ball by tightening the coupler nut.
- Cross the safety chains under the tongue and secure them to the towing vehicle in such a way as to prevent accidentally coming off. Crossing the safety chain helps prevent the tongue from dropping to the ground should the hitch come off.
- DO NOT LET THE CHAINS TOUCH THE GROUND OR BE DRAWN TOO TIGHT. Allow only enough slack to permit proper turning of the towing vehicle. Slack in the safety chain should be reduced until the tongue cannot hit the ground should the coupler come loose.
- The swivel jack or stand must be parallel with the tongue and pinned in place.
- The chipper hopper must be in the upright position and pinned in place.
- The rear flap must be pinned inside of the side plates.
- After towing for a few blocks stop and check that all connection points are securely connected.
- While towing exercise extreme caution, allow extra space between vehicles and expect longer stopping distance.
- Local laws vary. It is your responsibility to know and obey all laws on the road.

SEE FIGURE: TOWING SETUP on the next page.

TOWING SETUP

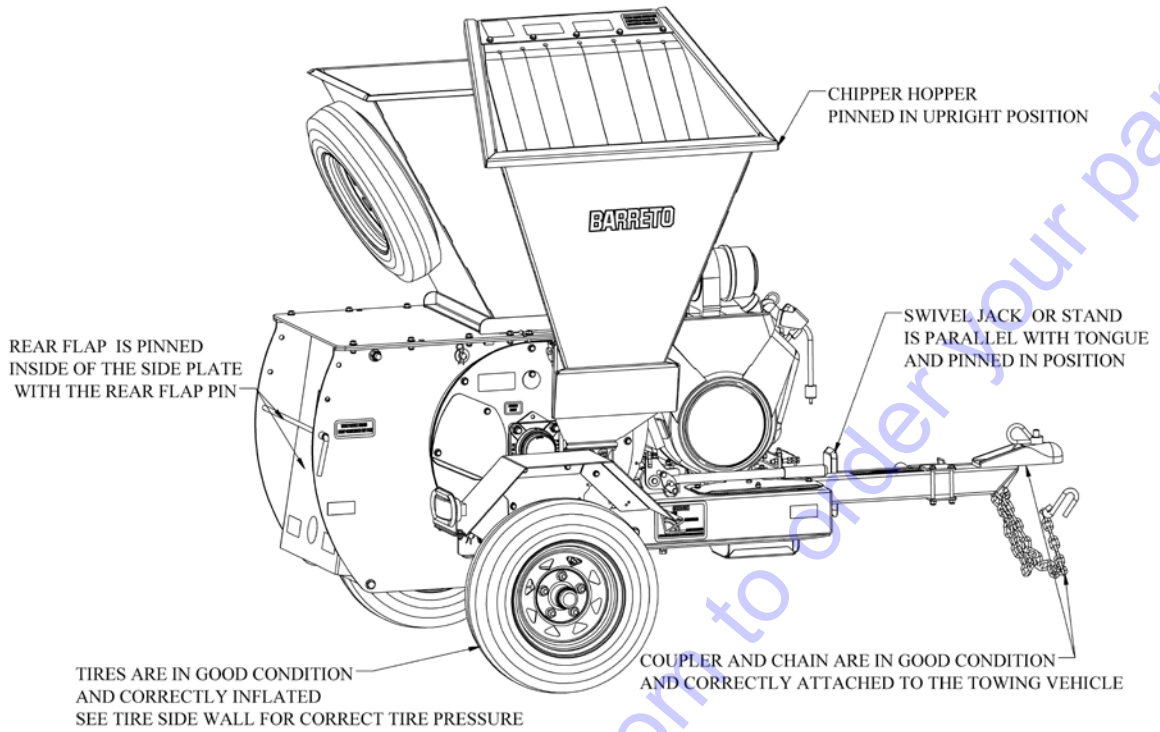

CMS MAJOR OPERATING COMPONENTS

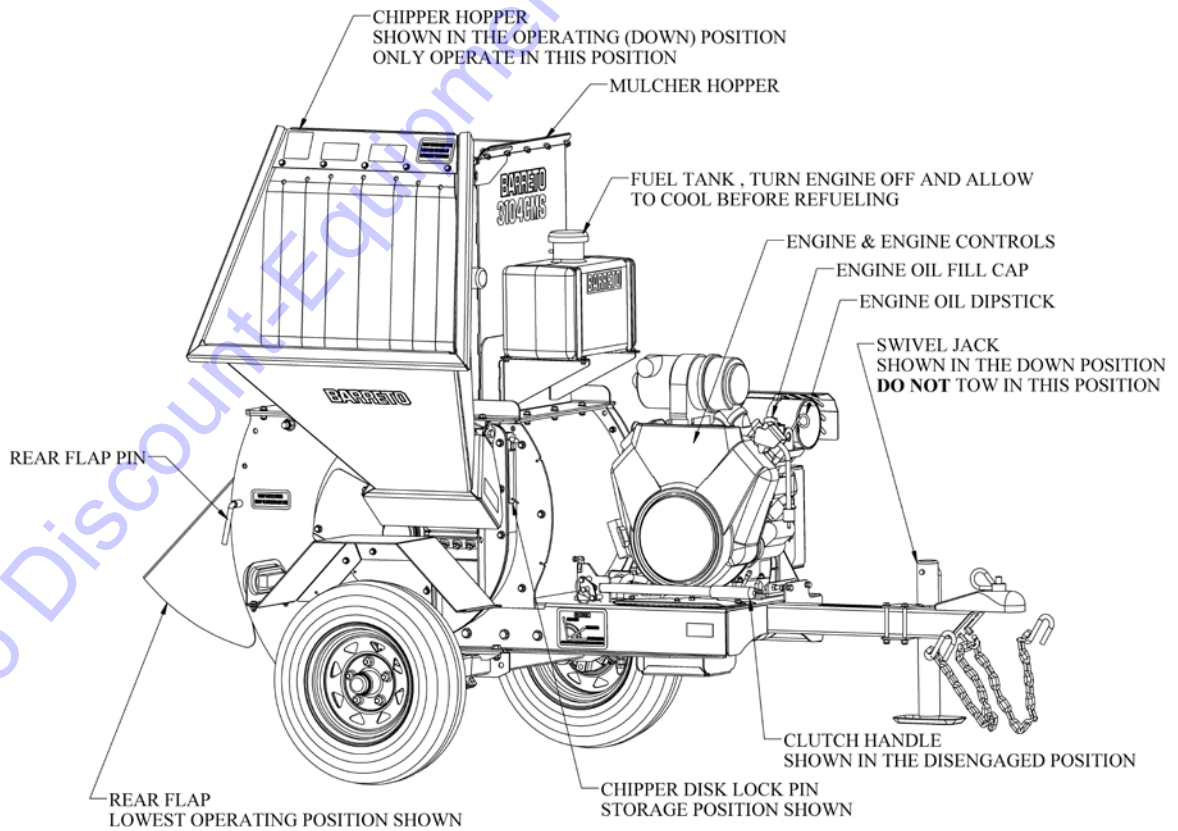

OPERATORS WORKING AREA

 **WARNING:** Stay clear of the areas, marked STAY CLEAR on the diagram below, while the CMS is running. Death or serious injury may occur.

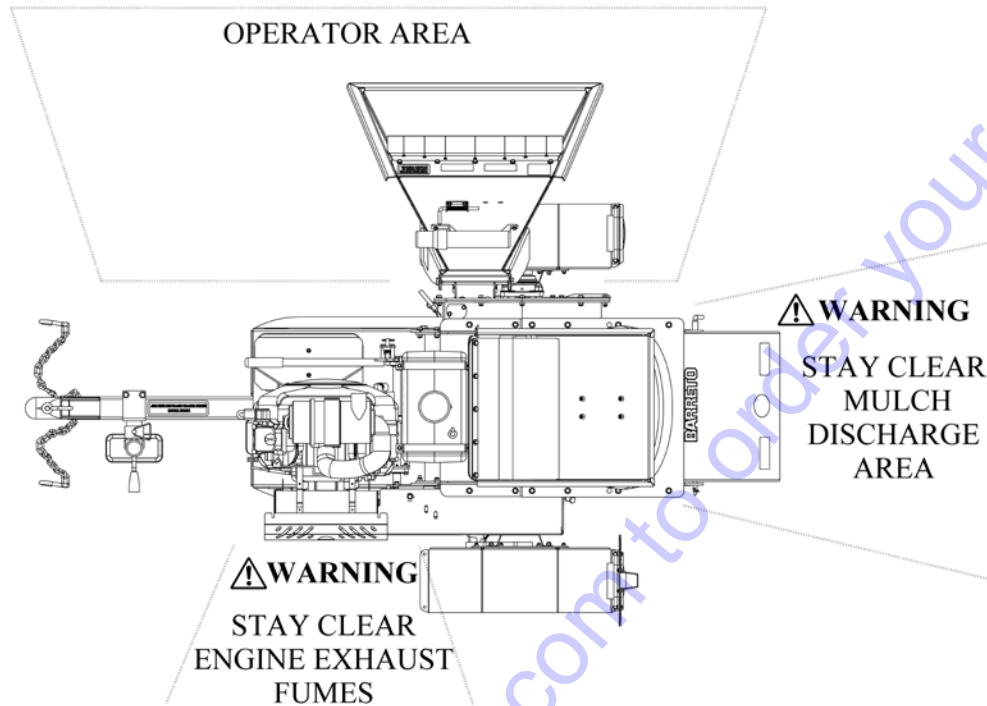

SETTING UP THE CMS

Pull the pin behind the chipper hopper (the chute on the side) and allow the chipper hopper to lower into its lowest position. The chipper hopper should lower under its own weight. It may need a slight nudge to get it started, just put a hand on it to prevent it from slamming.

 **WARNING:** Do not operate the CMS with the chipper hopper in its upright / transport position.

 **WARNING:** Do not put your fingers between the chipper hopper and the interior funnel while lowering the chipper hopper. They will get pinched.

Remove the rear flap pin, hold the rear flap up to the desired position and reinsert the rear flap pin so that the rear flap rests on the rear flap pin. Replace the cotter pin after inserting the rear flap pin. Assistance may be required.

If operating the CMS free standing without a towing vehicle, use the swivel jack to support the tongue and hold the CMS level. Use tire chocks to prevent the CMS from rolling.

If operating on a grade, chock the tires to prevent the CMS from rolling. The CMS may be left connected to a towing vehicle or operated free standing.

SEE FIGURE: CMS MAJOR OPERATING COMPONENTS on the previous page.

STARTING AND STOPPING THE ENGINE

Check engine oil:

The engine manufacturer, Vanguard™, recommends that the engine oil be checked daily, prior to use and after every 8 hours of use. Keep the engine oil level at FULL. Do not overfill.

Use the ENGINE OIL DIPSTICK shown in the diagram above to check the engine oil level.

1. Engine must be off and on level surface, clean around oil fill and dipstick.
2. Remove dipstick and wipe clean with a cloth.
3. Push dipstick all the way back in and remove to check oil level.
4. If oil is needed add slowly, using full synthetic 5w30 or 10w30 motor oil. Please notify the owner what kind of oil was added and how much when the CMS is returned.
5. Fill to FULL line on dipstick.(If needed)
6. Replace dipstick firmly.

Starting the engine:

Make sure the clutch is in the disengaged (DOWN) position before attempting to start the engine.

1. Open fuel shut-off valve
2. Move choke control to CHOKE or START
3. Move throttle to FAST
4. Push Rocker switch to ON or RUN (IF EQUIPPED)
5. Insert key and turn to START
6. Allow engine to warm up.
7. Slowly adjust the choke toward RUN position. Wait until engine runs smoothly before each choke adjustment.

Stopping the engine:

1. Disengage clutch: See “Disengaging the clutch” below.
2. Move throttle to slow.
3. Allow the chipper / mulcher to come to a complete stop.
4. Turn key to OFF. Remove key and store out of reach of children.
5. Close fuel shut-off valve.

NOTICE: Failure close the fuel shut-off valve may damage the engine and void the engine warranty.

ENGAGING AND DISENGAGING THE CLUTCH

Engaging the clutch: Without an intermediate clutch stop.

1. Adjust the engine throttle to about $\frac{3}{4}$ throttle.
2. Slowly rotate the clutch handle up. At about 35 degrees, you will notice an increase in pressure.
3. Hold the clutch lever just below where you feel the increase in pressure until the chipper / mulcher matches the engine speed.
4. Continue to rotate the clutch until the built in spring pressure holds it in its engaged position.
5. Increase throttle to full before feeding material.

Engaging the clutch: If equipped with an intermediate clutch stop.

1. Adjust the engine throttle to about $\frac{3}{4}$ throttle.
2. Slowly rotate the clutch handle up. At about 35 degrees, you will hit the intermediate clutch stop.
3. Hold the clutch against the clutch stop until the chipper / mulcher matches the engine speed.
4. Pull the pin at the bottom of the clutch and continue to rotate the clutch until the built in spring pressure holds it in its engaged position.
5. Increase throttle to full before feeding material.

Disengaging the clutch:

1. Pull / rotate the clutch down until the built in spring pressure holds it in the disengaged position.
2. Decrease engine throttle to slow.

FEEDING MATERIAL

To prevent the CMS from clogging:

- DO allow the chipper a moment to get back up to speed between feeding cycles.
- DO run the engine at full throttle.

- DO NOT feed material that is too large for the CMS into either hopper.
- DO NOT feed both hoppers simultaneously.

Feeding the chipper:

Feed the chipper hopper with tree limbs and branches up to 4 inches thick. Feed large leafy branches so that the leaves will be the last part in the chipper. Normally the branch will get stuck before the large leafy section enters the hopper.

With the large leafy section hanging out of the chipper hopper, remove it, without reaching into the chipper hopper. Allow a moment for the chipper to get back up to working speed and feed the soft leafy section into the mulcher hopper.

Feeding the mulcher:

Feed leafy sections into the mulcher hopper. The mulcher hopper will take sticks and branches 1 inch in diameter or less.



CAUTION: Release material over the mulcher hopper and allow it to fall into the mulcher hopper. Do not try to hold on to material as you feed it into the mulcher hopper.

NOTICE: ONLY PUT WOOD AND PLANT MATERIALS IN THE CMS, OTHER MATERIALS WILL DAMAGE THE MACHINE.

Remove mulch from behind the CMS:

As you chip shred and mulch, mulch will accumulate behind the CMS. When the pile nears the screen: disengage the clutch and stop the engine. Roll the CMS forward or shovel the debris away from the screen. The CMS can then be restarted and work can continue.

CLEARING DEBRIS CLOGS FROM THE CMS



DANGER: Never reach into the CMS, while running or capable of running. Reaching into the CMS will result in death or serious injury. The CMS must be rendered inoperable to reduce the chance of injury before attempting to clear mulcher clogs.

Chipper hopper clogs: A branch has become stuck in the chipper hopper:

If the branch is extending outside of the chipper hopper:

DO NOT reach into the chipper hopper. Grab the branch and remove or reposition it as necessary. If the largest branches on it are 1 inch or less in diameter it can and should be removed and tossed into the mulcher hopper. The CMS can be left running.

If the branch is inside the chipper hopper:

A longer branch or piece of wood may be used to attempt to remove or reposition the stuck branch.

If unable to remove the stuck branch with a longer branch or piece of wood:

Disengage the clutch, turn off the engine, remove the key and wait for the rotor to stop.

See procedures: Disengaging the clutch and Stopping the engine.

Remove the rear flap pin and use the handle side of the rear flap pin to remove the stuck branch. Once removed return the rear flap and the rear flap pin to their operating position, secure with the cotter pin

NOTICE: The engine must be off and the rotor must be completely stopped before putting something that is not plant material into the chipper hopper or the machine will be damaged.

Mulcher hopper clogs:

Before mulcher hopper clogs may be cleared the CMS lockout procedure must be followed.

LOCKOUT PROCEDURE

Lockout procedure: To render the CMS inoperable.

- 1. DISCONNECT THE BATTERY.**
- 2. REMOVE THE KEY.**
- 3. LOCK THE CHIPPER DISK.**

1. Disconnect the battery: See: BATTERY SAFETY INSTRUCTIONS first,

Disconnect the negative battery cable where the cable connects to the CMS chassis prevent the cable from touching any part of the engine or chassis. Then disconnect the negative cable from the battery. Store the cable where only the person performing the maintenance has access to the cable. (When reconnecting connect, the battery first, chassis second)



WARNING: The battery contains sulfuric acid that can cause blindness and severe burns. Avoid contact with eyes, skin and clothing. Read the section: BATTERY SAFETY INSTRUCTIONS, in this manual.

2. Remove the key:

Attempt to start the engine with the key after disconnecting the battery. This should ensure that any residual power in the system is drained. Turn the key to off and remove the key. Store the key where only the person performing the maintenance has access to the key.

3. Lock the chipper disk:

Loosen the bolt holding the chipper disk lock cover, swing the cover up and snug the bolt down. The chipper disk lock pin is stored behind and to the right of the chipper hopper. Insert the chipper disk lock pin into the lock hole and through the hole in the chipper disk. If needed, use the disk lock pin to turn the chipper disk until it can be inserted into the chipper disk. The disk can be turned in either direction. **Clog may prevent the chipper disk from turning, lock the disk as soon as possible.**



WARNING: DO NOT use your fingers, hands or any other body part to turn the chipper disk. The chipper is heavy and has sharp blades.

If the mulcher hopper clogs:

1. **Quickly disengage the clutch.** See procedures: Disengaging the clutch
2. **Stop the engine.** See procedure: Stopping the engine
3. **Follow the LOCKOUT PROCEDURE to render the CMS inoperable:**

If the clog is preventing the disk from turning: proceed to the next step, come back and insert the chipper disk lock pin as soon as possible.

4. Access the mulcher rotor:

- Raise the rear flap to its highest position and use the rear flap pin to hold it in this position.
- Remove the top screen pin and rotate the screen down.
- If the disk lock pin is not in place attempt to rotate the mulcher rotor with the top screen pin or a branch, do not reach inside the mulcher.



CAUTION: Parts inside and around the mulcher may be sharp or have sharp edges. Be careful to not cut yourself while clearing clogs or during assembly / disassembly.

5. Remove debris from around the mulcher rotor:

Tip: To get the mulcher rotor to rotate backwards, push on the bottom of the rotor with the top screen pin, which can unbind the initial clog.

- Remove **ALL** debris from inside the mulcher rotor compartment. Do not reach into the rotor compartment. Use the top screen pin or other branches to clear debris.
- Check that the mulcher rotor rotates freely and easily for at least 2 full turns.

6. Put the CMS back together:

- Raise the screen and re-insert the top screen pin, secure with cotter pin.
- Lower the rear flap and rear flap pin, secure with cotter pin.
- Remove disk lock pin from chipper disk and return to holder, secure with cotter pin.
- Return the disk lock cover back to its operating position and tighten the retaining bolt.

Double-check that everyone is clear of the machine and all components are back in their operating position, and then follow the procedure **STARTING THE ENGINE**.

CLEARING MULCHER CLOGS

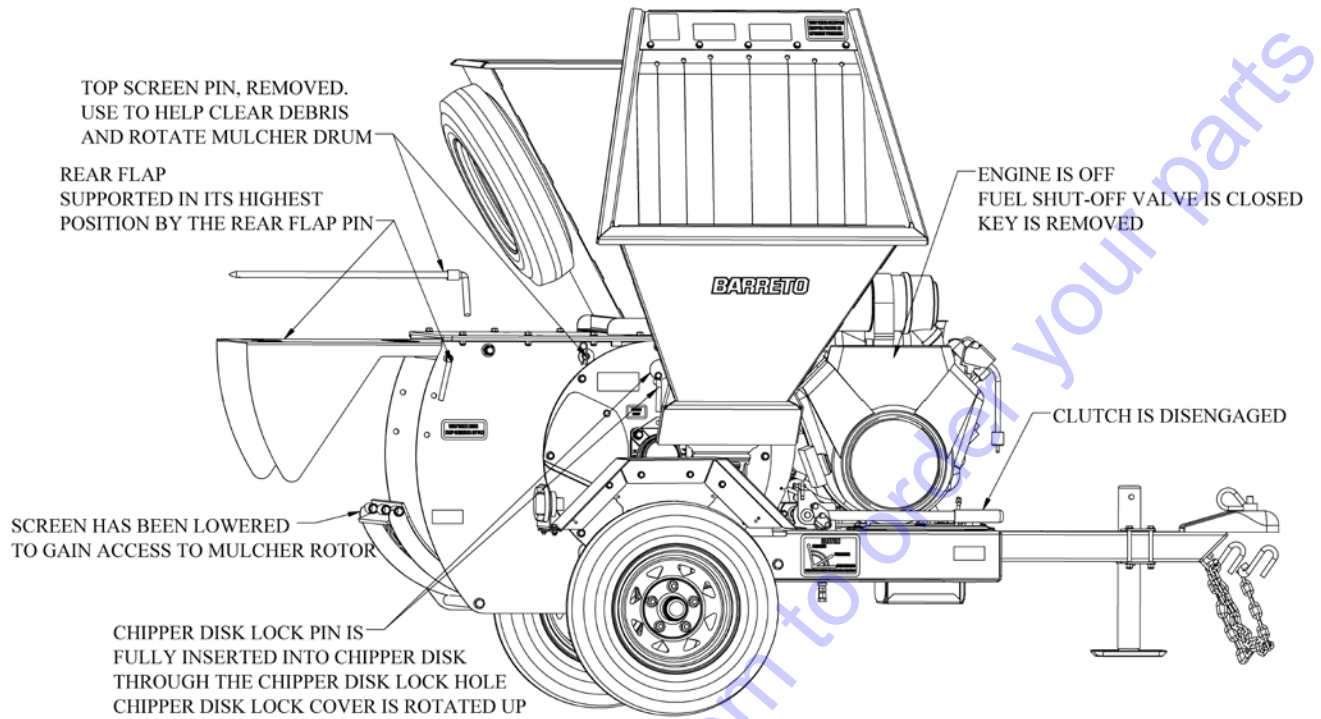

LUBRICATION / GREASE REQUIREMENTS

Grease at the intervals indicated in the following illustration of grease points. Wipe away excess grease, KEEP GREASE OFF OF BELTS.

3104CMS GREASE POINTS

- 1&2: DRUM BEARING GREASE DAILY OR EVERY 6 HOURS OF USE
 - 3&4: CLUTCH PULLEY GREASE WEEKLY OR EVERY 25 HOURS OF USE
- WIPE AWAY EXCESS GREASE, KEEP GREASE OFF OF BELTS

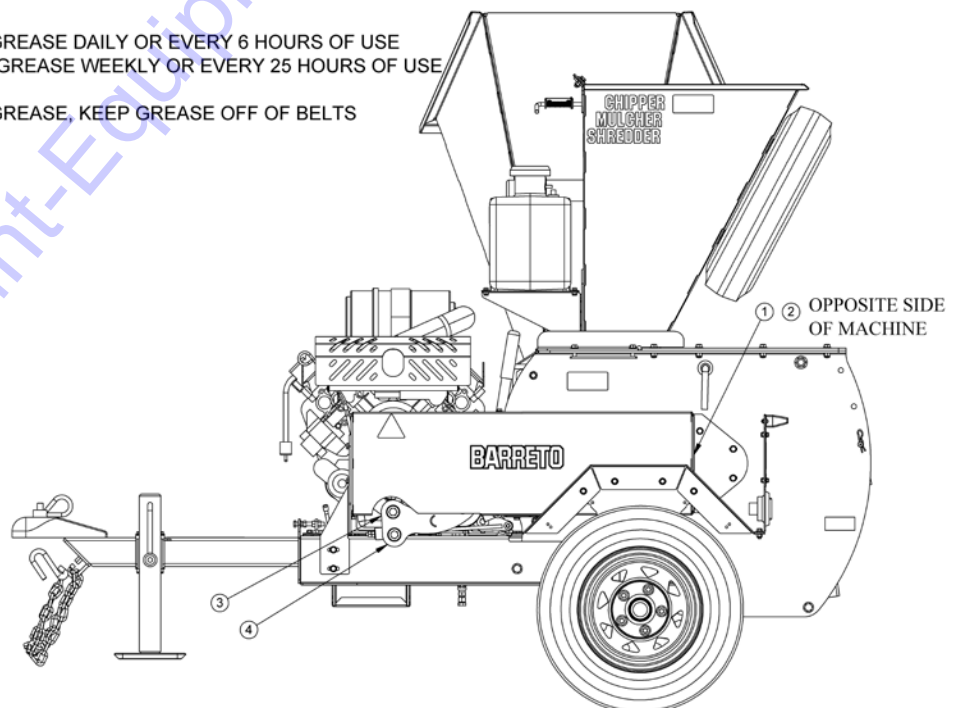

CMS OPERATORS TROUBLE SHOOTING GUIDE



WARNING: Always use extreme care when troubleshooting or making adjustments on the CMS. Stop engine, close fuel shut-off valve, and remove key before disassembling any component.

Engine dies when clutch is engaged:

1. Engine RPM / throttle too low: Increase engine throttle
2. Clutch engaged too quickly: Engage clutch slower, See CLUTCH ENGAGEMENT
3. Debris stuck in chipper or mulcher drum. See CLEARING DEBRIS CLOGS

Engine back fires when clutch is disengaged:

1. Clutch pulley not moving correctly: Grease the clutch pulley, See Lubrication requirements.
2. Engine not positioned correctly: *For 2 & 3 Inform the owner or see Owner's manual section:*
3. Clutch pins not positioned correctly: *BELT INSTALLATION / REPLACEMENT*

CMS stalls as soon as material is fed:

1. **Engine & Rotor stalls / stops:** Run engine at full throttle
2. **Rotor stops, engine runs:** Make sure that you have the clutch engaged, adjust the nut at the bottom of the clutch lever. Taking the nut out further will increase belt tension.

Issues and solutions covered here assume that the CMS operator is not the owner and only covers in field solutions. If other problems arise or your problem is not resolved contact the owner or refer to your owner's manual.

PARTS FINDER

**Search Website
by Part Number**



**Search Manual
Library For Parts
Manual & Lookup Part
Numbers – Purchase
or Request Quote**

Search Manuals

Enter your information to help us find the right part for your machine.

* Brand:

* Model:

* Serial:

* Part Number:

SEARCH

**Can't Find Part or
Manual? Request Help
by Manufacturer,
Model & Description**

Parts Order Form

Please fill in the following information to help us find the right part for your machine.

Manufacturer:	<input type="text"/>
Model:	<input type="text"/>
Description:	<input type="text"/>
Part Number:	<input type="text"/>
Quantity:	<input type="text"/>
Notes:	<input type="text"/>

Submit

Discount-Equipment.com is your online resource for quality parts & equipment.

Florida: **561-964-4949** Outside Florida TOLL FREE: **877-690-3101**

Need parts?

Click on this link: <http://www.discount-equipment.com/category/5443-parts/> and choose one of the options to help get the right parts and equipment you are looking for. Please have the machine model and serial number available in order to help us get you the correct parts. If you don't find the part on the website or on one of the online manuals, please fill out the request form and one of our experienced staff members will get back to you with a quote for the right part that your machine needs.

We sell worldwide for the brands: Genie, Terex, JLG, MultiQuip, Mikasa, Essick, Whiteman, Mayco, Toro Stone, Diamond Products, Generac Magnum, Airman, Haulotte, Barreto, Power Blanket, Nifty Lift, Atlas Copco, Chicago Pneumatic, Allmand, Miller Curber, Skyjack, Lull, Skytrak, Tsurumi, Husquvarna Target, Stow, Wacker, Sakai, Mi-T-M, Sullair, Basic, Dynapac, MBW, Weber, Bartell, Bennar Newman, Haulotte, Ditch Runner, Menegotti, Morrison, Contec, Buddy, Crown, Edco, Wyco, Bomag, Laymor, EZ Trench, Bil-Jax, F.S. Curtis, Gehl Pavers, Heli, Honda, ICS/PowerGrit, IHI, Partner, Imer, Clipper, MMD, Koshin, Rice, CH&E, General Equipment, Amida, Coleman, NAC, Gradall, Square Shooter, Kent, Stanley, Tamco, Toku, Hatz, Kohler, Robin, Wisconsin, Northrock, Oztec, Toker TK, Rol-Air, APT, Wylie, Ingersoll Rand / Doosan, Innovatech, Con X, Ammann, Mecalac, Makinex, Smith Surface Prep, Small Line, Wanco, Yanmar