

フレーム (1)
FRAME (1)

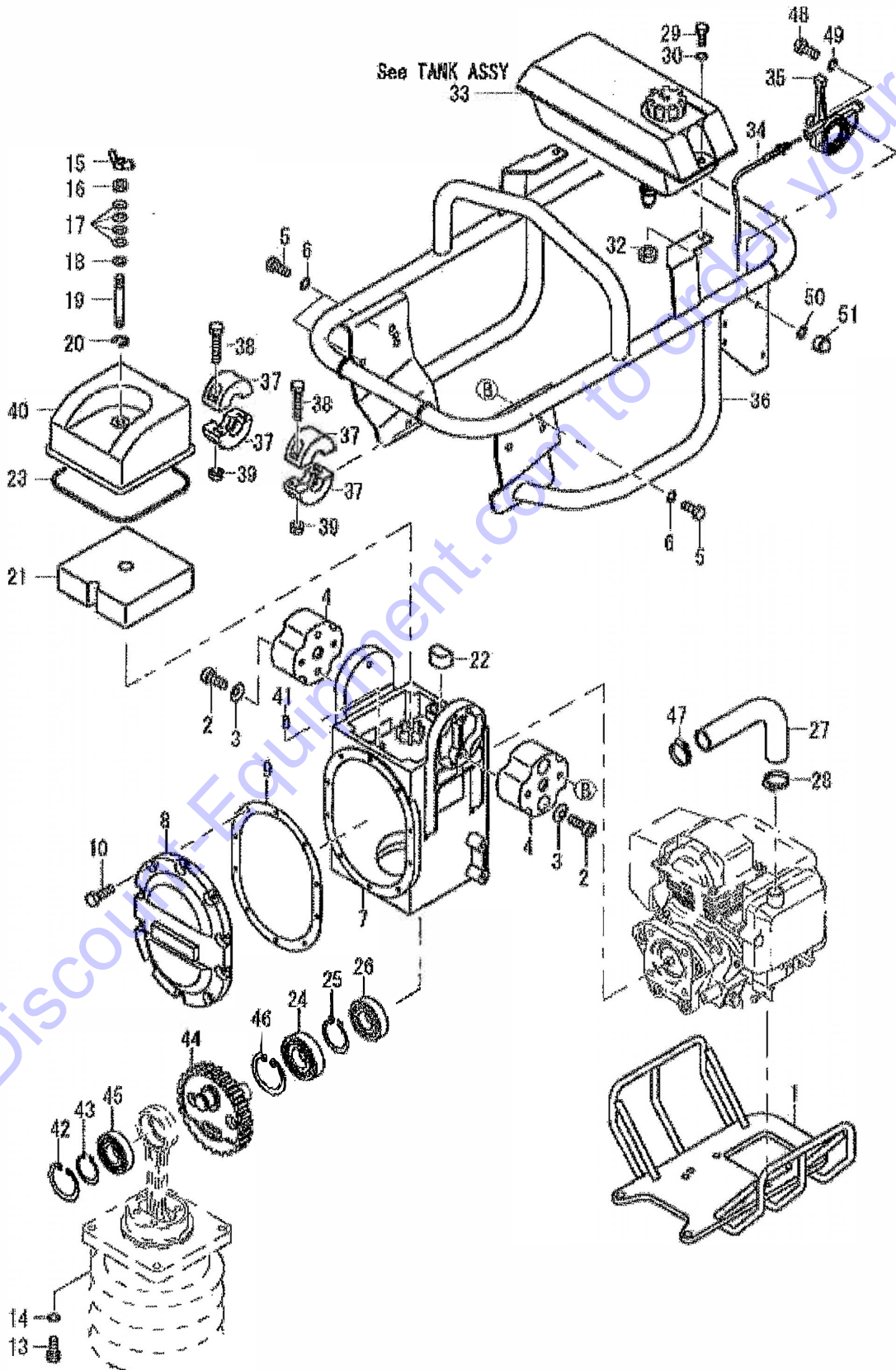

No.	PartsName	PartsNo.	Q t y	Remark
1	GUARD	1466-47061-1	1	
2	BOLT	1472-12062-0	4	
3	CONICAL SPRING WASHER	2172-08012-1	4	
4	DAMPER	1467-47029-0	2	
5	BOLT	1472-12100-0	4	
6	SPRING WASHER	2171-08020-0	4	
7	CASE	1466-47098-3	1	
8	COVER	1466-47151-0	1	
9	PACKING	1466-47056-0	1	
10	BOLT	3100-00153-0	10	
13	BOLT	2100-10040-1	2	
14	SPRING WASHER	2171-10025-0	2	
15	NUT	1466-47078-0	1	
16	NUT	1466-47077-0	1	
17	CONED DISC SPRING	2461-10001-0	4	
18	WASHER	2170-10020-0	1	
19	BOLT	1466-47073-0	1	
20	E-RETAINING RING	2194-00708-2	1	
21	FILTER	1466-47045-0	1	
22	FILTER	1466-47048-0	1	
23	PACKING	1466-47102-0	1	
24	BALL BEARING	2501-06207-0	1	
25	C-RETAINING RING	2194-03515-0	1	
26	BALL BEARING	2501-06305-0	1	
27	HOSE	1466-47029-0	1	
28	CLAMP	4712-40000-0	1	
29	BOLT	1472-12062-0	2	
30	WASHER	2170-08020-1	2	
32	NUT	3120-00109-0	2	
33	TANK ASSY	0466-47017-0	1	
34	CABLE	1466-47103-0	1	
35	LEVER ASSY	0466-47002-1	1	
36	HANDLE	1467-47039-0	1	
37	ROLLER	1462-47064-0	4	
38	BOLT	4712-99000-0	4	
39	NUT	4713-00000-0	4	
40	CASE	1466-47027-0	1	
41	SPRING PIN	2150-06014-0	1	

42	C-RETAINING RING	2194-05220-1	1
43	C-RETAINING RING	2194-02512-0	1
44	GEAR	1468-47028-0	1
45	BALL BEARING	2501-06205-0	1
46	C-RETAINING RING	2194-07225-1	1
47	CLAMP	3291-01037-0	1
48	BOLT	2100-06020-1	2
49	WASHER	2170-06016-0	2
50	SPRING WASHER	2171-06015-0	2
51	NUT	1466-47075-0	2

Go to Discount-Equipment.com to order your parts

フレーム (2) FRAME (2)

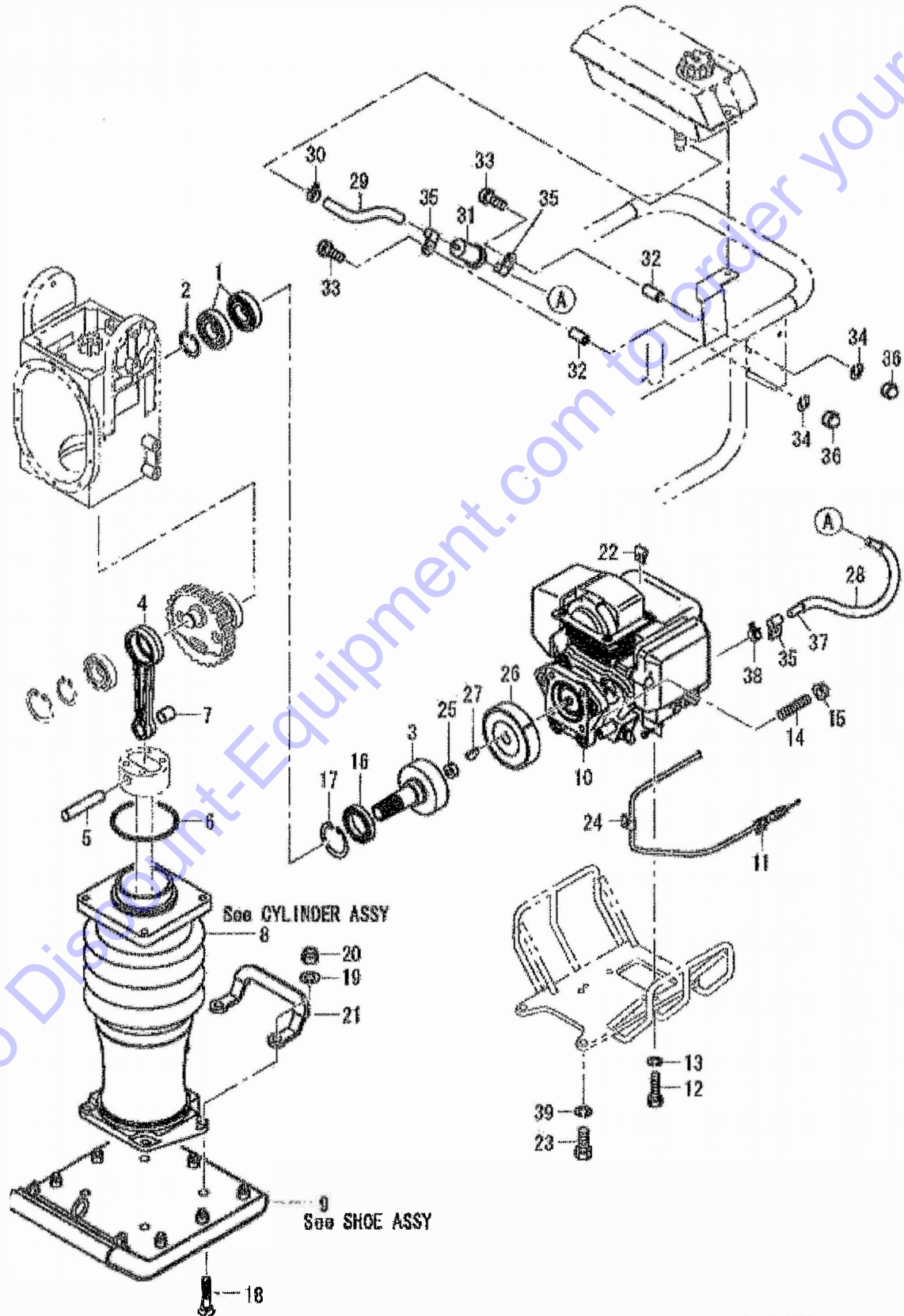

No.	PartsName	PartsNo.	Qty	Remark
1	BALL BEARING	2501-06206-0	2	
2	C-RETAINING RING	2194-03015-0	1	
3	PINION	1468-47007-0	1	
4	CONROD	1466-47034-0	1	
5	PIN	1466-47040-0	1	
6	O-RING	2630-01105-1	1	
7	BUSH	1579-47100-0	1	
8	CYLINDER ASSY	0467-47009-1	1	
9	SHOE ASSY	0467-47001-0	1	
10	ENGINE	4032-05000-3	1	GX100
11	CLAMP	1462-47083-0	1	
12	BOLT	2100-08030-1	4	
13	SPRING WASHER	2171-08020-0	4	
14	BOLT	4031-37001-0	4	
15	NUT	3120-00109-0	4	
16	OIL SEAL	2600-02386-0	1	
17	C-RETAINING RING	2194-06220-1	1	
18	BOLT	1462-47032-1	4	
19	SPRING WASHER	2171-12030-0	4	
20	NUT	1579-47290-0	4	
21	HOOK	1466-47096-0	1	
22	CLAMP	1570-47137-0	1	
23	BOLT	2100-10050-1	2	
24	CLAMP	3416-02034-0	1	
25	NUT	2121-12100-0	1	
26	CLUTCH	4413-93000-1	1	
27	KEY	1755-47611-0	1	
28	TUBE	1466-47100-0	1	
29	HOSE ASSY	1467-47041-1	1	
30	CLAMP	1466-47143-0	1	
31	FILTER	1469-47072-0	1	
32	PIPE	1469-47080-0	2	
33	BOLT	2100-06035-1	2	
34	SPRING WASHER	2171-06015-0	2	
35	CLAMP	1467-47043-0	3	
36	NUT	1466-47075-0	2	
37	HOSE	1467-47044-1	1	
38	CLAMP	1466-47143-0	1	

シリンダASSY CYLINDER ASSY

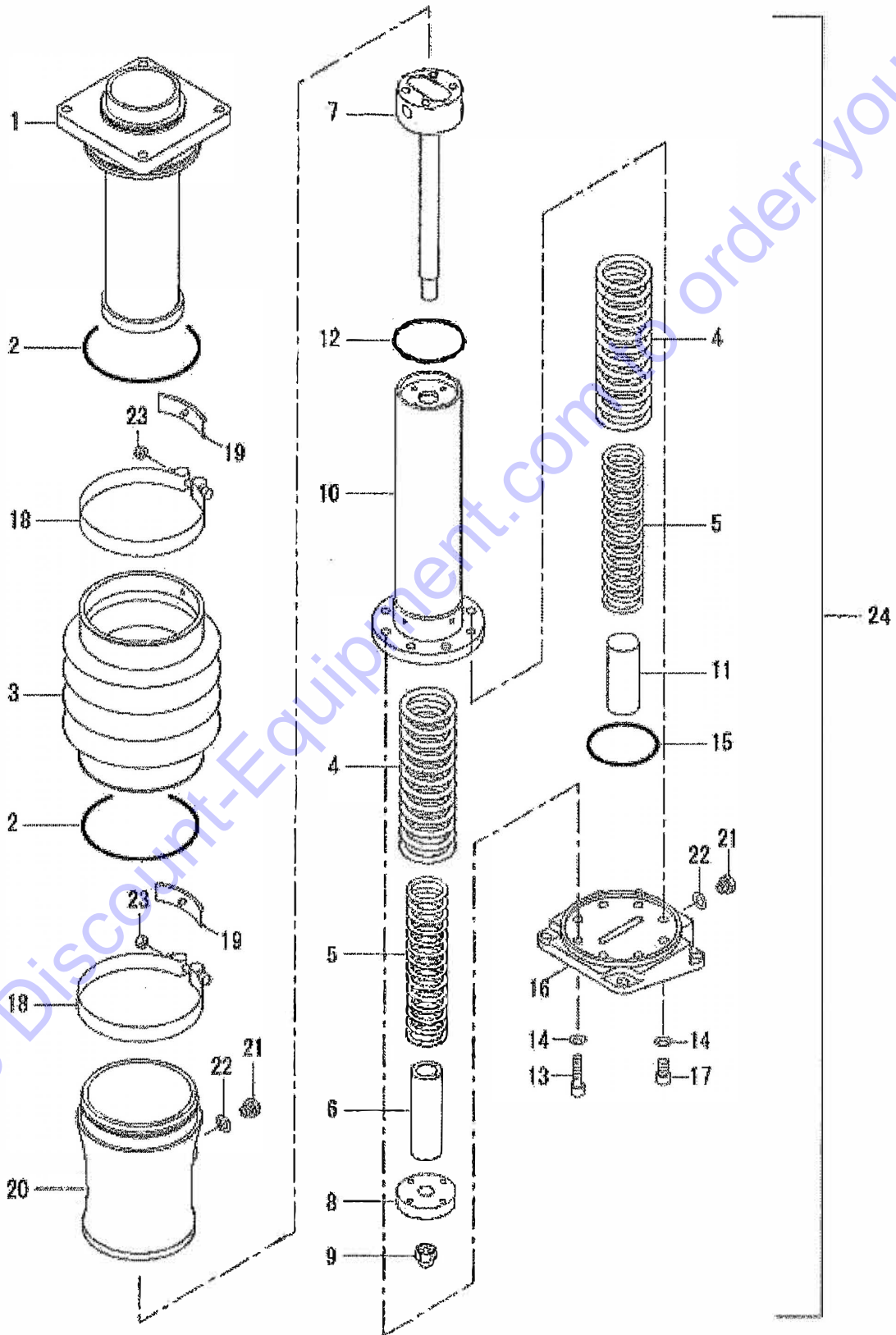

Go to Discount-Equipment.com to order your parts

No.	PartsName	PartsNo.	Q t y	Remark
1	CYLINDER	1466-47099-0	1	
2	O-RING	2630-01140-1	2	
3	BELLOWS	1466-47150-0	1	
4	SPRING	1466-47008-0	2	
5	SPRING	1468-47001-0	2	
6	STOPPER	1466-47003-0	1	
7	PISTON	1466-47035-0	1	
8	SLIDER	1466-47039-0	1	
9	NUT	1466-47006-0	1	
10	CYLINDER	1466-47177-0	1	
11	STOPPER	1466-47004-0	1	
12	O-RING	2630-01090-1	1	
13	BOLT	2107-10040-3	4	
14	CONICAL WASHER	2172-10015-1	8	
15	O-RING	2630-01085-1	1	
16	ADAPTER	1467-47023-0	1	
17	BOLT	2107-10020-3	4	
18	CLAMP	1466-47042-0	2	
19	PAD	1466-47046-0	2	
20	OIL PAN	1466-47176-0	1	
21	PLUG	1590-47024-0	2	
22	PACKING	1466-47062-0	2	
23	NUT	2120-08065-0	2	
24	CYLINDER ASSY	0467-47009-1	1	INC.1-23

Go to Discount-Equipment.com to order your parts

シューASSY

SHOE ASSY

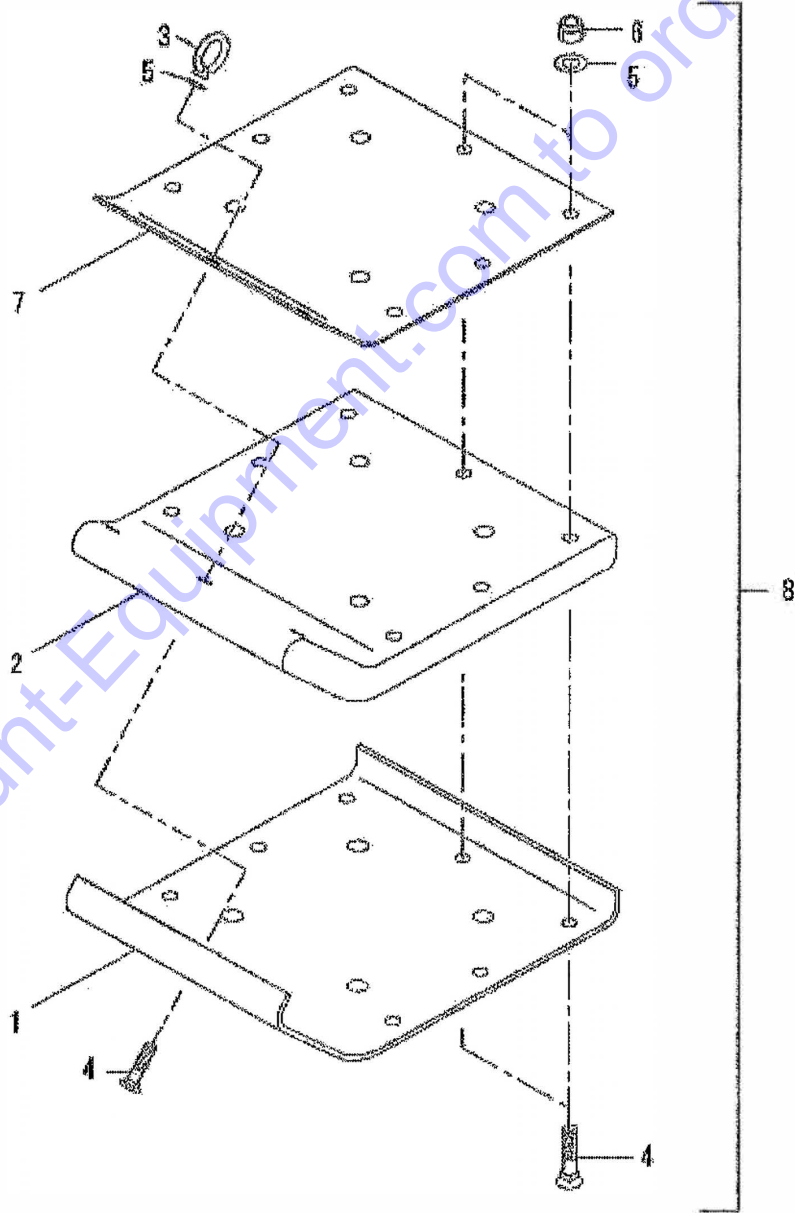

No.	PartsName	PartsNo.	Q t y	Remark
1	PLATE	1467-47008-0	1	A/S(CF.8)
2	SHOE	1467-47009-0	1	A/S(CF.8)
3	EYE NUT	3120-41008-0	1	
4	BOLT	1578-47516-0	10	
5	SPRING WASHER	2171-10025-0	10	
6	NUT	1579-47320-0	9	
7	PLATE	1467-47010-0	1	A/S(CF.8)
8	SHOE ASSY	0467-47001-0	1	INC.1-7

Go to Discount-Equipment.com to order your parts

タンク ASS'Y
TANK ASS'Y

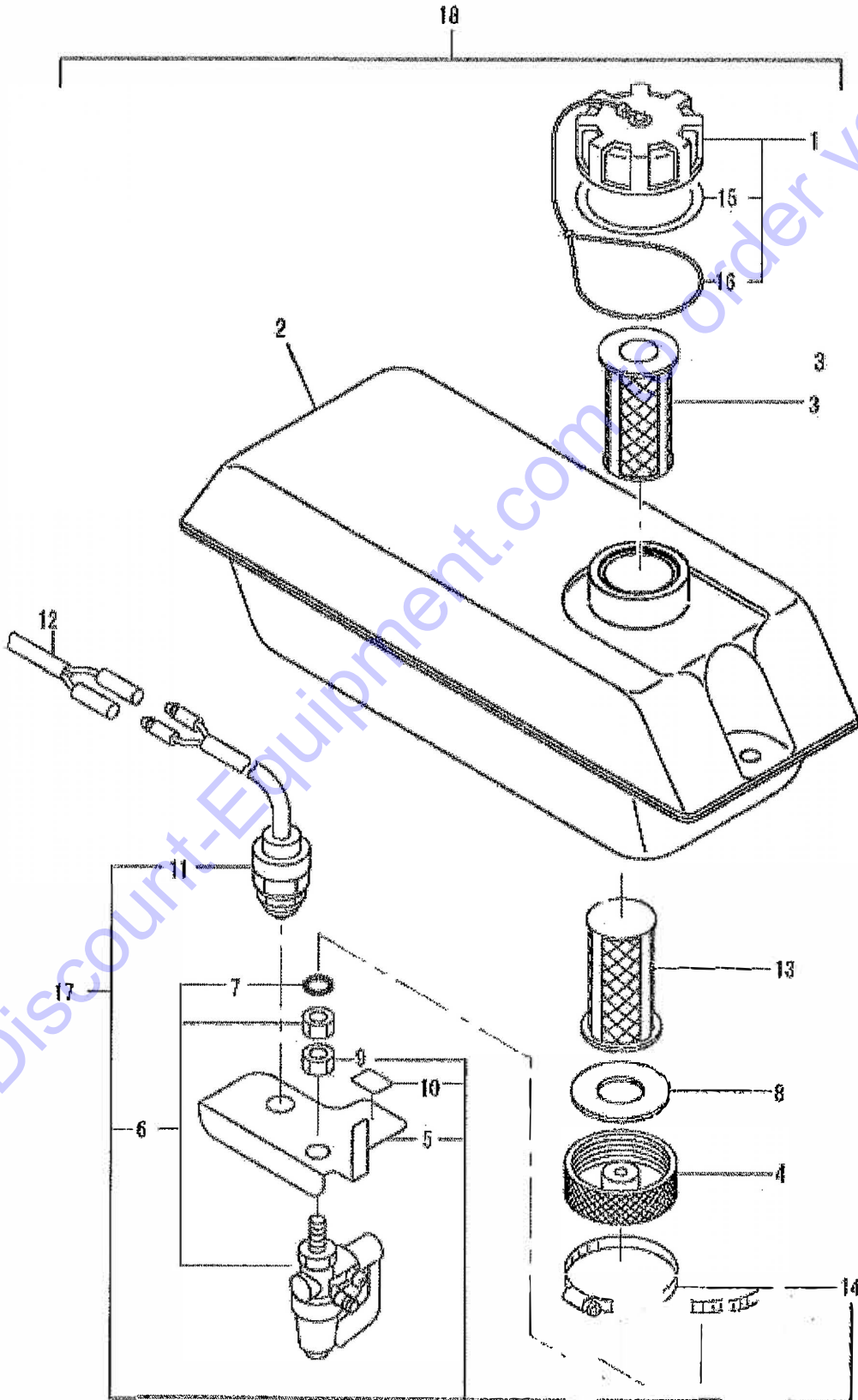

Go to Discount-Equipment.com to order your parts

No.	PartsName	PartsNo.	Q t y	Remark
1	CAP	4190-09006-7	1	INC.15 16
2	TANK	4718-21000-0	1	
3	STRAINER	4707-20000-1	1	
4	CAP	1466-47125-0	1	
5	BRACKET	1466-47168-0	1	
6	COCK	4707-18000-5	1	INC.7
7	O-RING	2631-03007-0	1	
8	PACKING	4707-19000-4	1	
9	NUT	1462-47114-0	1	
10	DICAL	1466-47169-0	1	
11	SWITCH	4911-98000-0	1	
12	HARNESS	1463-47069-0	1	
13	STRAINER	4715-07000-0	1	
14	CLAMP	3291-02036-0	1	
15	PACKING	4190-09009-0	1	
16	STRAP	4190-09010-0	1	
17	SWITCH ASSY	0466-47016-0	1	INC.5-7 9-11 14
18	TANK ASSY	0466-47017-0	1	INC.1-14

Go to Discount-Equipment.com to order your parts

レバー ASSY
LEVER ASSY

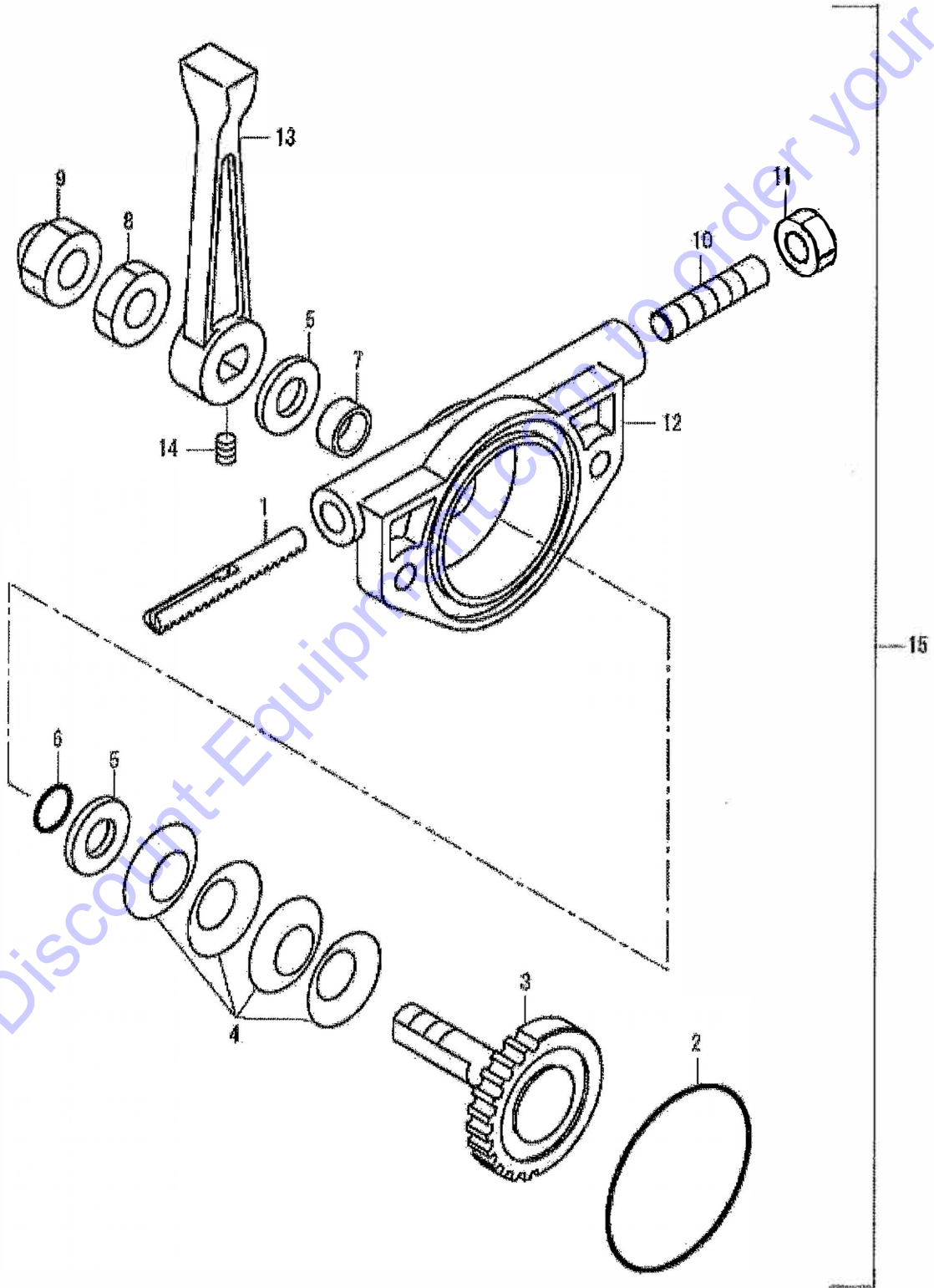

Go to Discount-Equipment.com to order your parts

No.	PartsName	PartsNo.	Q t y	Remark
1	RACK	1466-47033-0	1	N/S
2	O-RING	2630-01045-1	1	
3	PINION	1466-47032-0	1	N/S
4	CONED DISC SPRING	2461-10001-0	4	
5	WASHER	2170-10020-0	2	
6	O-RING	2630-01010-0	1	
7	BUSH	2580-10008-1	1	
8	NUT	1466-47077-0	1	
9	NUT	1466-47076-0	1	
10	SET SCREW	2180-08020-0	1	
11	NUT	2120-08065-0	1	
12	CASE	1466-47030-0	1	N/S
13	LEVER	1466-47162-0	1	
14	SET SCREW	2180-06006-0	1	
15	LEVER ASSY	0466-47002-1	1	INC.1-14

Go to Discount-Equipment.com to order your parts

PARTS FINDER

**Search Website
by Part Number**



**Search Manual
Library For Parts
Manual & Lookup Part
Numbers – Purchase
or Request Quote**

Search Manuals

Enter your information to help us find the right parts manual for your machine.

* Brand:

* Model:

* Serial:

* Part Number:

SEARCH

**Can't Find Part or
Manual? Request Help
by Manufacturer,
Model & Description**

Parts Order Form

Please fill in the following information to help us find the right part for your machine.

Manufacturer:	<input type="text"/>
Model:	<input type="text"/>
Description:	<input type="text"/>
Part Number:	<input type="text"/>
Quantity:	<input type="text"/>
Notes:	<input type="text"/>

Submit

Discount-Equipment.com is your online resource for quality parts & equipment.

Florida: **561-964-4949** Outside Florida TOLL FREE: **877-690-3101**

Need parts?

Click on this link: <http://www.discount-equipment.com/category/5443-parts/> and choose one of the options to help get the right parts and equipment you are looking for. Please have the machine model and serial number available in order to help us get you the correct parts. If you don't find the part on the website or on one of the online manuals, please fill out the request form and one of our experienced staff members will get back to you with a quote for the right part that your machine needs.

We sell worldwide for the brands: Genie, Terex, JLG, MultiQuip, Mikasa, Essick, Whiteman, Mayco, Toro Stone, Diamond Products, Generac Magnum, Airman, Haulotte, Barreto, Power Blanket, Nifty Lift, Atlas Copco, Chicago Pneumatic, Allmand, Miller Curber, Skyjack, Lull, Skytrak, Tsurumi, Husquvarna Target, Stow, Wacker, Sakai, Mi-T-M, Sullair, Basic, Dynapac, MBW, Weber, Bartell, Bennar Newman, Haulotte, Ditch Runner, Menegotti, Morrison, Contec, Buddy, Crown, Edco, Wyco, Bomag, Laymor, EZ Trench, Bil-Jax, F.S. Curtis, Gehl Pavers, Heli, Honda, ICS/PowerGrit, IHI, Partner, Imer, Clipper, MMD, Koshin, Rice, CH&E, General Equipment, Amida, Coleman, NAC, Gradall, Square Shooter, Kent, Stanley, Tamco, Toku, Hatz, Kohler, Robin, Wisconsin, Northrock, Oztec, Toker TK, Rol-Air, APT, Wylie, Ingersoll Rand / Doosan, Innovatech, Con X, Ammann, Mecalac, Makinex, Smith Surface Prep, Small Line, Wanco, Yanmar