



MASONRY SAW

BSM1402

OWNER'S MANUAL





Discount-Equipment.com

REV.	DATE	DESCRIPTION	APPROVED BY:

SAFETY PRECAUTIONS



DANGER
EXPLOSION HAZARD

Never operate the machine in an explosive atmosphere, near combustible materials or airborne dust, or in areas if inadequate ventilation.



CAUTION
ROTATING HAZARD

Never place hands or fingers inside safety guard or near rotating blade. Serious injury will result from contact with rotating blade.



CAUTION
MOVING PARTS

Before starting the machine, ensure that all guards and safety devices are in place and functioning properly.



ATTENTION
READ OWNER'S MANUAL

Read and understand owner's manual before using this machine. Failure to follow operating instructions could result in serious injury or death.

TABLE OF CONTENTS

WARRANTY INFORMATION	4
SAFETY INFORMATION	5
FEATURES	7
SPECIFICATIONS	7
HEALTH WARNING	8
UNPACKING	8
SET UP	9
SAW STAND FOLDABLE LEGS	9
ASSEMBLY AND OPERATION	10
BLADE INSTALLATION	10
WATER PUMP INSTALLATION	10
WHEEL INSTALLATION	11
USING THE CUTTING TABLE	11
PERFORMING STRAIGHT CUTS	12
PERFORMING DIAGONAL CUTS	12
PERFORMING MITER CUTS	12
SETTING THE CUTTING DEPTH	13
CLEANING THE WATER TRAY	13
TRANSPORTING THE SAW	13
PROPER BLADE USE	14
CARE AND MAINTENANCE	15
GENERAL RULES	15
CLEANING	15
PROLONGED PERIOD OF NON-USE	16
EXTREME TEMPERATURE	16
WATER PUMP MAINTENANCE	16
BELT REPLACEMENT	17
REALIGNMENT	18
LEVELING ADJUSTMENT	20
ELECTRICAL SPECIFICATIONS	21
EXTENSION CORD CHART	22
ELECTRICAL WIRING DIAGRAM	22
TROUBLESHOOTING	23



WARRANTY INFORMATION

All products sold by Bartell Morrison Inc. and Bartell Morrison (USA) LLC (the Company) are warranted against defects in materials and/or workmanship for a period of 12 months; excluding the normal wear on wearing components and components covered by a separate original manufacturer's warranty. The warranty is to the original end user purchaser provided that certain conditions have been met.

Conditions:

1. The equipment serial number has been registered with the Company or its approved dealers, distributors, and representatives or agents.
2. The equipment has been operated in an appropriate manner by qualified individuals.
3. The equipment has been properly maintained as per the instructions included in the Owner's Manual.
4. All claims for warranty must be filed on proper forms and include the serial number of the equipment along with proof of purchase.

Any evidence of failure to meet these conditions may result in a denial of the warranty claim.

Consideration of warranty claims will be at the sole discretion of the Company, or its authorized dealers, distributors, representatives or agents.

The Company may, at its discretion, request that the equipment to be considered for warranty be returned at the owner's expense to an authorized repair facility for inspection.

Under this warranty, we may, at our discretion, replace the defective portion of the equipment and a reasonable (as determined by the Company) amount of labour to conduct the repair or replacement.

Under no circumstances shall the Company be liable for any additional or exceptional costs beyond the cost to repair or replace the defective portion of the equipment. The Company shall not be held accountable for; costs associated with travel to inspect or repair defective equipment, cost for transporting equipment at any facility other than one authorized by the Company or ancillary damage caused by or as a result of defective equipment.

Under no circumstances shall equipment be returned to the Company or its authorized dealers, distributors, representatives, or agents without the approval of the Company as evidence by a Returned Goods Number. To obtain a Returned Goods Number contact the factory or your authorized dealer, distributor, representative or agent.

This warranty is for the sole benefit of the original end user purchaser and is not transferrable to any other company or person.

SAFETY INFORMATION

Before using this equipment, study the entire owner's manual to become familiar with its operation. Do not allow untrained or unauthorized personnel, especially children, to operate this equipment. Use only factory authorized parts for service.

- A.** Saw blade should be inspected daily for excessive wear, core cracks and arbor damage. Replace any blade that shows signs of damage.
- B.** To mount the blade, clean the arbor and outer flanges, and tighten the nut securely.
- C.** DO NOT place any portion of your body in line with the blade while it is rotating.
- D.** Wet cutting blades MUST be used with water.
- E.** To reduce the risk of electrical shock, we recommend the use of GFCI and to refer servicing to a qualified professional.
- F.** Before operating the saw, along with studying the owner's manual, be sure to wear proper safety gear, such as hearing protection, safety glasses, and dust mask. A hard hat is also recommended.



- G.** Never use the machine improperly or work in an unsafe manner.
- H.** Maintain alertness while operating the machine. Failure to maintain attention, by the operator, may lead to serious injury.
- I.** Keep work area clean.
- J.** Before you start working, familiarize yourself with the work site and its surroundings. Take notice of circumstances which may impede work or traffic, observe soil conditions (good bearing or not) and take measures to ensure safety (e.g. the shielding of roadworks from public traffic).
- K.** Take measures to ensure that the machine is in a safe and trouble-free condition prior to usage. Use the machine only when all protective devices (i.e. guards, noise absorbers, emergency-off devices) are in place and in working order.
- L.** A visual check of the machine must be made at least once a shift to ensure that visible damages or faults are recognized. Any changes (including changes in the performance or

behavior of the machine) must be reported to the supervisor. If necessary, stop the machine at once and secure it.

- M.** In the case of a malfunction, stop the machine immediately and secure it. Fix the problem as soon as possible.
- N.** To stop and start the machine follow the operating instructions and observe any indicator lights.
- O.** Keep out of reach of children. Before operating machine, be sure the activated machine will be of no danger to anyone.
- P.** Be sure to connect the plug to a properly grounded receptacle to reduce the risk of electric shock.
- Q.** Wear proper apparel. Do not wear loose clothing or accessories. Keep hair and body parts away from openings and moving parts.
- R.** If cord/plug is damaged do not operate.
- S.** Make sure power switch is in **off** position before plugging in power cord to prevent any accidental activation.
- T.** When machine is plugged in do not leave it unattended. Unplug prior to servicing, when changing accessories, and when not in use.
- U.** Never carry machine by cord. Do not pull cord to unplug. Keep cord away from heat, sharp edges and oil.
- V.** Do not operate the machine when you are tired or while under the influence of drugs, alcohol or any medication.
- W.** Never operate this unit when flammable materials or vapors are present. Electrical devices produce sparks or arcs which can cause a fire or explosion.
- X.** When using an extension cord, make sure it is in good condition and heavy enough to carry the current drawn by the machine. Refer to the extension cord table in the **Electrical Specifications** section for the correct gauge depending on the desired cord length and the machine's horse power and voltage.

FEATURES

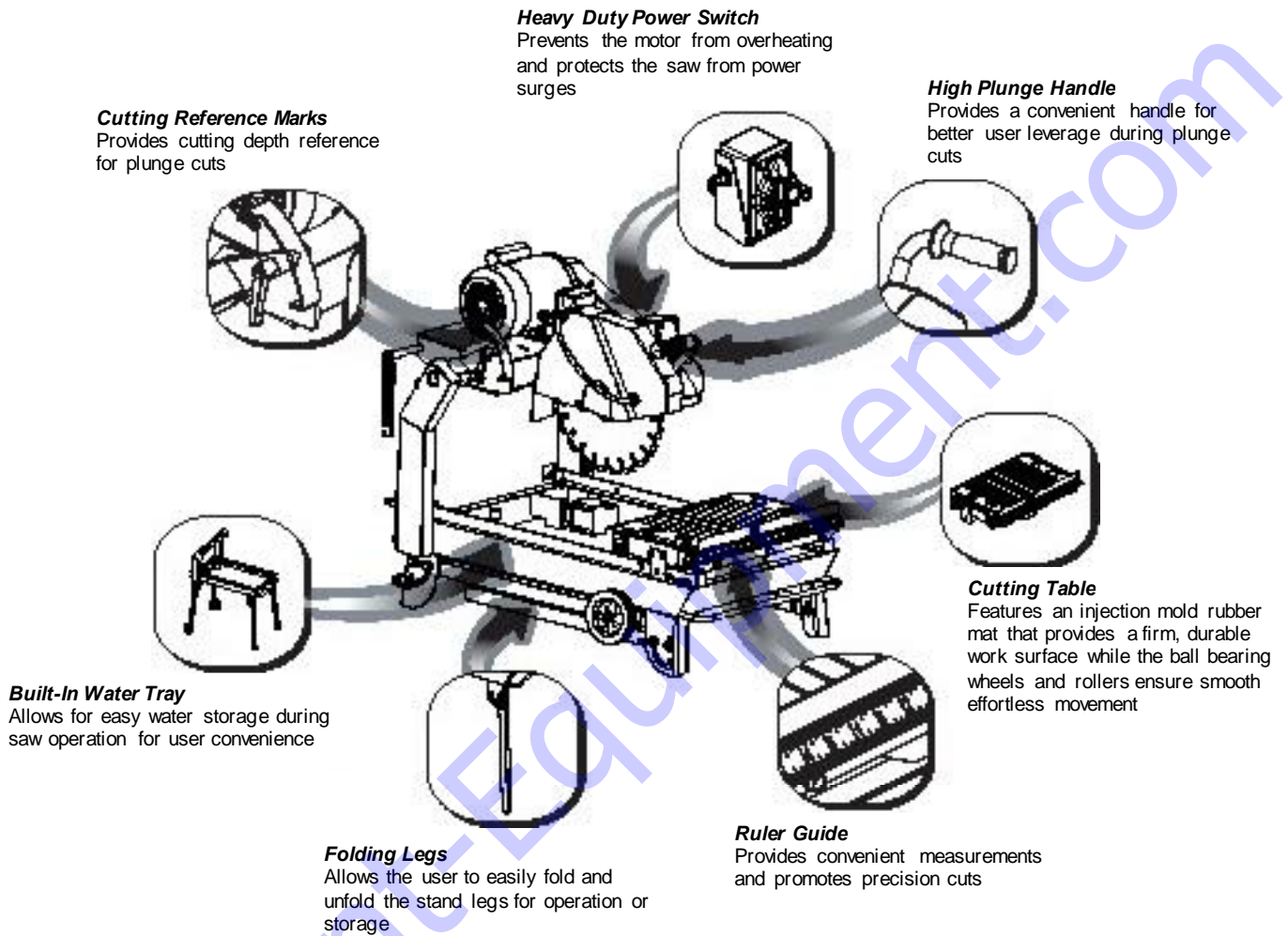

SPECIFICATIONS

Motor	Max. Blade Capacity	Cutting Depth	Weight	Dimensions
2 HP, 115-120 V, 60 Hz, 3420 RPM	14+	4-1/2+	207 lbs	Length: 40.5+ Width: 23.2+ Height: 31.7+



HEALTH WARNING

Some dust created by power sanding, sawing, grinding, drilling, and other construction activities contain chemicals known to cause cancer, birth defects or other reproductive harm. Some examples of these chemicals are:

- ~ Lead from lead-based paints,
- ~ Crystalline silica from bricks, cement and other masonry products, and
- ~ Arsenic and chromium from chemically-treated lumber.

Your risk from these exposures varies, depending on how often you do this type of work. To reduce your exposure to these chemicals: Work in a well-ventilated area, and work with approved safety equipment, such as those dust masks that are specially designed to filter out microscopic particles.

UNPACKING

Open the package and carefully lift the saw and place it on a flat, level working area. Be sure that you have the following items before you discard the package:

- ~ Saw
- ~ Manual
- ~ Water pump
- ~ Universal wrench
- ~ Rip guide
- ~ Miter block
- ~ Overflow drain plug
- ~ Wheel Set
- ~ Bucket

SET UP

Saw Stand Foldable Legs

1. To deploy the foldable legs, unscrew the wing bolts located at the corner of the frame of the leg to be deployed. Only unscrew the wing bolts far enough so that the leg is movable. Do not remove the wing bolts.
2. Starting at the rear lift the saw and pull the leg towards the rear. Be mindful that the leg will rotate downwards once it is free of the horizontal portion of the slot.
3. Once the leg is in the vertical position, make sure it slides into the vertical portion of the slot (figure 1). Hand tighten the wing bolt. Repeat for the other rear leg.
4. Now slide in the safety pins hanging from the rear of the saw into the available hole below the wing bolt (figure 2).
5. Lift the front of the saw and pull the front foldable leg down. Be mindful that the leg will swing down rapidly after it is pulled down a certain degree.

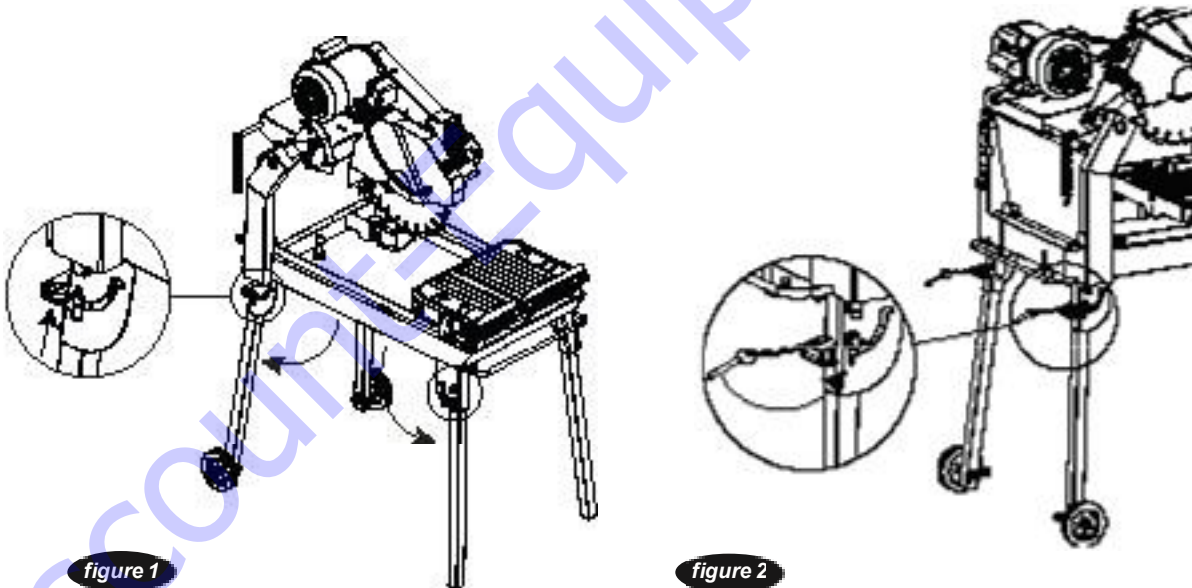

Note: If the saw is too heavy to handle on your own ask for assistance. Failure to do so can result in bodily injury!

ASSEMBLY AND OPERATION

Blade Installation

1. Open the blade nut door found on the blade guard by rotating it. Using the supplied wrench, loosen the nut.
2. Remove the nut and the outer flange.
3. Install a new blade. Make sure the blade rotation arrow coincides with the rotation direction of the blade shaft.
4. Reattach the outer flange and blade nut.
5. Using the same wrench tighten the blade nut and close the blade nut door.

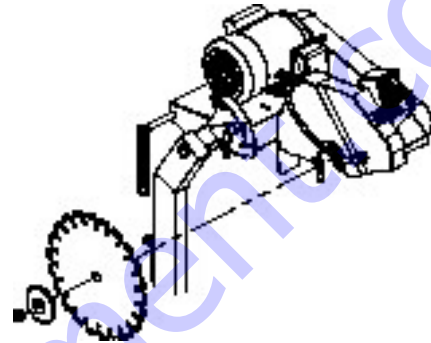

figure 3

Water Pump Installation

1. Hang the optional water bucket on the hook found at the rear center of the saw frame.
2. Place the water pump inside the water bucket (figure 4).
3. If no water bucket is available, place the water pump inside the water tray behind the splash guard (figure 5).

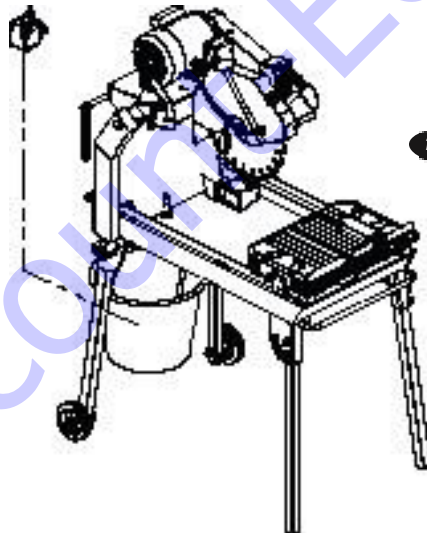

figure 4

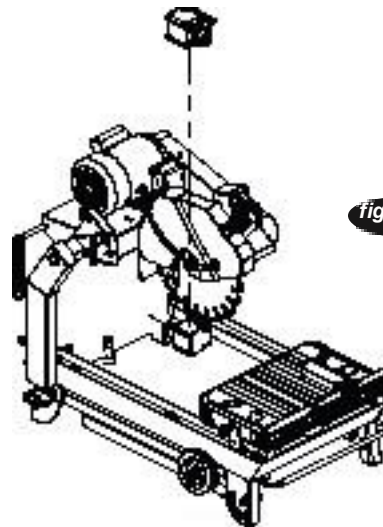

figure 5

⚠ WARNING:

*Disconnect the pump before attempting to handle the pump.
Never operate pump without water in the tray.*

Wheel Installation

1. Wheel assembly can be installed on the frame or the rear folding legs (see figure 6).
2. To remove the wheel assembly, slide the spring pin out of its current slot and pull the wheel out. Put it in the desired location and reinsert the pin. The pin should be inserted all the way in and always in the inner slot, when given a choice

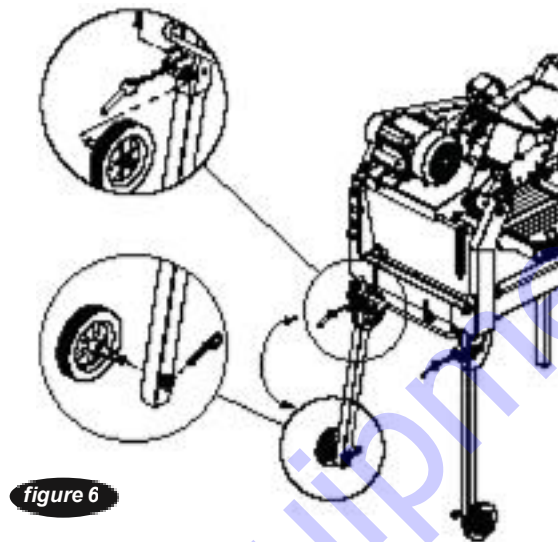

figure 6

Using the Cutting Table

- “ The ruler guide has inches marked along the top to allow convenient measurements and to promote precision cuts (figure 7).

The wide cutting table spans an area of 19+x 12+, providing a large work area to efficiently handle large materials.

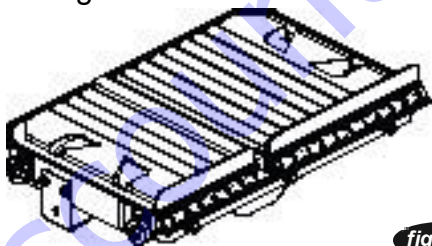

figure 7

- “ The cutting table is covered by a rubber mat that provides a firm, durable work surface.
- “ The masonry rip guide should be used together with the cutting table to ensure precision while making cuts.

Performing Straight Cuts

1. Set the rip guide at the desired location on the ruler guide and tighten the threaded knob. Make sure the rip guide is firmly tightened to avoid slippage.
2. After the rip guide is positioned for the desired cut, place the material being cut flat against the side of the rip guide and the ruler guide.
3. Now you are ready to make your cut.
4. Thicker material may need to be cut, flipped over, and cut again to complete separation.

Performing Diagonal Cuts

The masonry rip guide is designed to secure the material in a variety of angles during the cut for improved accuracy.

1. Adjust the rip guide to the desired cutting angle.
2. Set the rip guide at the desired location on the ruler guide and tighten the threaded knob. Make sure the rip guide is firmly tightened to avoid slippage.
3. After the rip guide is positioned for the desired cut, place the material being cut appropriately on the cutting table.
4. Now you are ready to make your cut.
5. Thicker material may need to be cut, flipped over, and cut again to complete separation.

Performing Miter Cuts

1. Place the lip of the miter block on the ruler guide with the threaded knob facing you.
2. Position the miter block such that the material's edge can lay all the way inside the vertical channel of the cutting table. One flat face of the material should lay flush against the miter block. Tighten the threaded knob to secure the miter.
3. Place material onto miter block and you are ready to cut

Setting the cutting Depth

Blade Diameter	Cutting Depth
10+	2+
12+	3 +
14+	4½+

WARNING:

Setting the blade too low may damage the cutting table and if set too high, the blade may grab the material being cut, possibly causing injury to the operator and the saw.

The recommended cutting depth is ¼+below the cutting table surface. To adjust the cutting depth, loosen the cutting depth control knob and set the cutting head such that the lowest point of the blade is ¼+below the table surface.

Cleaning the Water Tray

1. Remove the drain plug and water pump. Drain any water left inside the water tray.
2. Wash water tray to remove sludge buildup.
3. Wipe down water tray until clean.

Transporting the Saw

1. Ensure that the water tray is empty and dry.
2. Unplug the power cord and store it in the water tray.
3. Secure the cutting table in the middle of the saw using the quick release pin anchored on the left post.

PROPER BLADE USE

	Dos	Don'ts
Wet Cut Blades	<ul style="list-style-type: none"> " Inspect blades daily for cracks or uneven wear. " Always use appropriate blade for material being cut. " Inspect arbor shaft for uneven wear before mounting blade. " Always use blades with the correct arbor shaft size. " Ensure that blade is mounted in the correct direction. " Use proper safety equipment when operating the saw . " Always have a continuous flow of water on both sides of blade. " Secure the blade to the arbor with a wrench. 	<ul style="list-style-type: none"> " Do not operate the saw without safety guards in position. " Do not operate the saw with blades larger than 14". " Do not cut dry with blades marked "Use Wet". " Do not exceed manufacturer's recommended maximum RPM. " Do not force blade into material. Let blade cut at its own speed.
Dry Cut Blades	<ul style="list-style-type: none"> " In addition to the following, always follow wet recommendations. " Use appropriate blade for material being cut. " Inspect segment blades for segment cracking or loss. " Do not use damaged blades. " Use proper safety equipment when operating the saw . 	<ul style="list-style-type: none"> " In addition to the following, always follow wet recommendations. " Do not make long cuts with dry blades. Allow them to air cool. " Do not use the edge or side of blade to cut or grind. " Do not attempt to cut a radius or curve. " Do not cut too deep or too fast into the material. " Do not cut any material not recommended by blade manufacturer.

CARE and MAINTENANCE

⚠ WARNING:

For your safety, before performing any maintenance on the saw turn OFF the power switch and UNPLUG the power cord.

General Rules

- ~ Always clean the machine before performing any maintenance/repair.
- ~ Before performing any cleaning/maintenance/repair, the machine must be switched off with the main power switch.

Steps to Follow When Cleaning:

- ~ Please do not use aggressive cleaners (i.e. containing solvents). Do not use high-pressure water jets, aggressive detergents or solutions and liquids with a temperature exceeding 86°F! Use a fluff-free cloth only.
- ~ Use a cloth which may be lightly moistened only for removing dust and dirt. Hard packed dirt can be removed with a soft brush.
- ~ For the sake of safety, no water/cleaning liquid/vapor may penetrate into the electric motor, connectors/plugs, switches, etc. Therefore, cover all apertures, holes in the housing, connectors or plugs, etc. or seal them with adhesive tape!
- ~ Use a soft, low-pressure water jet and a brush to rinse dirt and incrustations away. Be particularly careful when near hazardous parts of the machine (e.g. switch, motor). Clean the motor and switches only by wiping with a moist cloth.
- ~ Do not rinse the bearings of the drive elements to prevent them from running dry. The ball bearings of the machine are permanently lubricated.
- ~ After cleaning, remove all covers and adhesive tape! All screws/nuts which you may have loosened must be tightened again!
- ~ After wet cleaning, try the machine on a power outlet which is equipped with a power breaker (i.e. fault current circuit breaker). If the fault current circuit breaker cuts the power supply, the machine must be inspected by an authorized dealer prior to use!

Cleaning

After every use of the machine:

- ~ Remove dirty water from container.
- ~ Remove dirt and mud from the bottom of the container.

- ~ Rinse the immersion pump with fresh water to prevent the water pump from clogging with residual dirt.

After wet cleaning and before using the machine again:

- ~ Connect the machine to an electric power outlet equipped with a GFCI safety power breaker. If the safety power breaker cuts off the electrical power supply, do not try to operate the machine but have it checked by an authorized dealer first.

Prolonged Period of Non-use

Before not using the machine for a prolonged period of time:

- ~ Clean and lubricate all movable parts. However, do not grease the guide rails.

After not using the machine for a prolonged period of time:

- ~ Check that the stand is safely fixed.
- ~ Check that all screw joints and nuts are fixed.
- ~ Check that the cutting table is seated properly on the guide rails and that it moves easily along the entire length of the rails.
- ~ With the saw blade removed, switch on the motor for an instant and switch it off again. If the motor does not run, have the machine inspected by a qualified electrician.
- ~ Check that the immersion pump works properly. Turn on the cooling water tap and switch the machine on. If the pump does not give any water or only a little, switch the machine off at once. Clean the pump, or replace if necessary.

Extreme Temperature

Ambient temperature below 32° F (Winter):

- ~ To prevent the water in the pump and cooling system from freezing, remove the water after using the machine or when there will be a long break. Make sure that the cooling system is entirely drained so that there is no water left inside the pump and water hose!

Water Pump Maintenance

When the machine has not been used for a long period of time, hard packed dirt may begin to build up inside the pump and block the pump wheel. If the machine is activated with the immersion pump blocked, the electric motor of the pump will be damaged within a few minutes! Please follow the steps listed below to clean the pump before operating the saw:

1. Remove the immersion pump from the water container.
2. Clean the immersion pump.
3. Loosen the screws of the pump lid.

4. Take the lid off the pump. Be careful not to damage or lose the gasket underneath.
5. Clean the pump lid.
6. Remove all dirt and incrustations from the pump wheel.
7. Check whether the pump wheel can be easily turned.
8. Then reassemble the immersion pump correctly and check whether it works properly.

Belt Replacement

1. Unplug the saw before proceeding any further.
2. Loosen and remove the four bolts located above and below the belt guard and then remove the belt guard (figure 8).
3. Remove the shield under the cutting head to access the four nuts locking the four motor bolts in place.
4. Loosen the four nuts located under the cutting head, near the base of the motor.
5. Use a wrench to turn the socket hex bolt located at the rear of the cutting head. Turn wrench to move the motor forward, thus providing some slack in the belt.
6. The motor shaft should be parallel with the blade shaft. If it is not, the two belts will have different tensions. This will cause the motor/belt to create a sound while operating.
7. Remove existing belt and replace with a new belt.

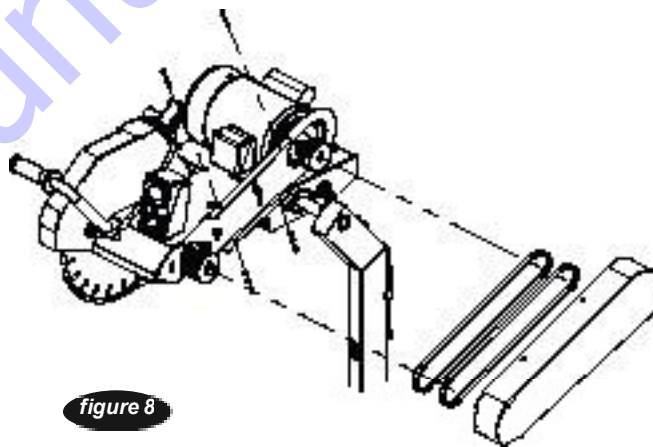

Realignment

Method 1:

This procedure deals with the most common source of misalignment that occurs when the guide rails are not parallel with the blade.

1. Set the cutting depth such that the blade passes through the table, not over.
2. Place a straight edge (i.e. carpenter's square) on the cutting table as shown in figure 9.
3. Loosen the left guide rail by loosening the fasteners found at the ends of the rail (figure 9). The left rail should be slightly loose, so there is not too much play during adjustments.

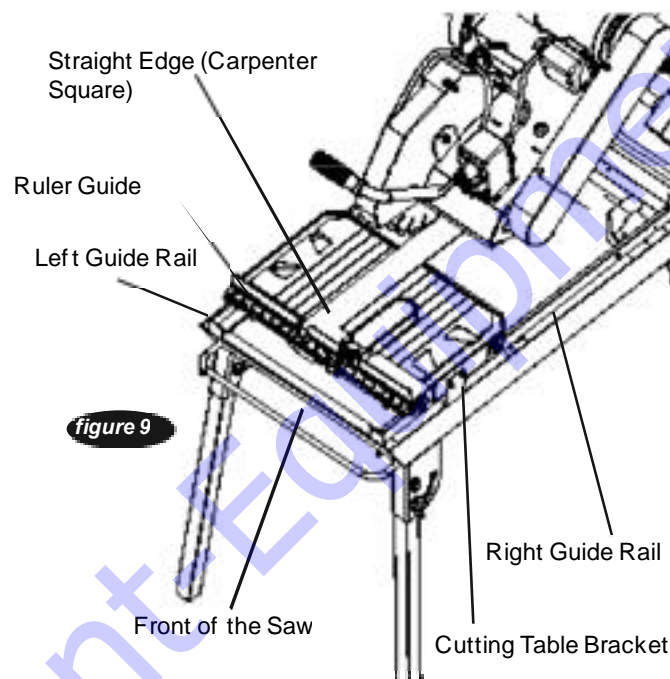

4. Make sure the short portion of the straight edge is placed flush against the ruler guide. Adjust the left guide rail so that the front and rear edges of the blade touch the straight edge, although a tolerance of 0.2mm between the front and rear edges is allowed. Perform this adjustment along the entire length of the straight edge.
5. Position the table as close to the user as possible. Place the straight edge flush against the ruler guide and blade. Without holding onto the straight edge, gently move the table towards the rear of the saw and then back. Observe any gaps that may appear between the straight edge and blade or between the straight edge and ruler guide. A gap exceeding the allowed tolerance means that the table is not moving parallel to the blade; hence, further adjustments as outlined in step 4 will be required. However, if scenario A or B described below occurs, other adjustments may be required instead.

A. If the straight edge only touches the blade when the table is positioned midway along the rail or at the ends of the rail, then the rail may be deformed (i.e. bowed) (figure 10). Perform test cuts to determine if the rail should be replaced. Typically, a bowing displacement of up to 0.5mm will not affect cutting accuracy.



Figure10

B. If the straight edge touches both edges of the blade initially, but shifts apart as the table travels along the rail, proceed to method 2 below.

6. Tighten the fasteners at both ends of the left rail. Make sure the right guide rail is always near the middle of the right rollers on the cutting table. If that is not the case adjust the right guide roller.

If alignment has been achieved do not proceed to method 2.

Method 2:

This procedure corrects another source of misalignment that occurs when the table's orientation is not parallel with the guide rails.

1. Loosen the cutting table bracket on both the left and right side of the cutting table.
2. If the table shifts to the right as it travels away from the user, a shim needs to be added to the guide roller furthest from the ruler guide. On the other hand, if the table shifts to the left, a shim needs to be added to the guide roller closest to the ruler guide.
3. To add the shim(s), lift the table from the guide rails. Turn the table over and set it on the guide rails. Remove the appropriate guide roller to insert a shim between the roller and the table, then reattach (figure 11). Depending on the severity of the shift, more than one shim may be required.

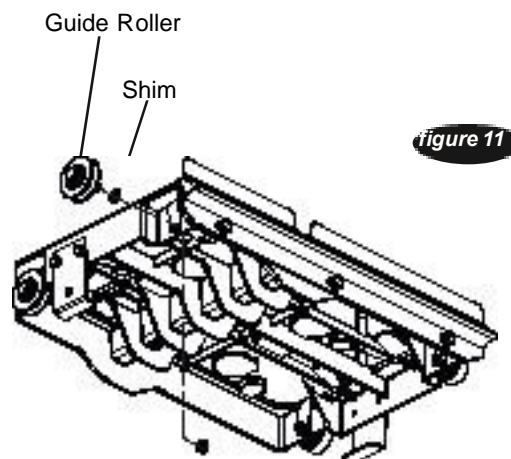

figure 11

4. After adding shim(s), mount the table back onto the guide rails. Realign the table to the blade using **Method 1**. Check to see if any shifting persists. A shift tolerance of 0.5mm is allowed. A shift in excess of that will require further adjustment. repeat step 3.

Leveling Adjustment

This procedure levels the table so that it is perpendicular to the blade and flush against the rails.

1. Loosen the cutting table brackets (figure 12).

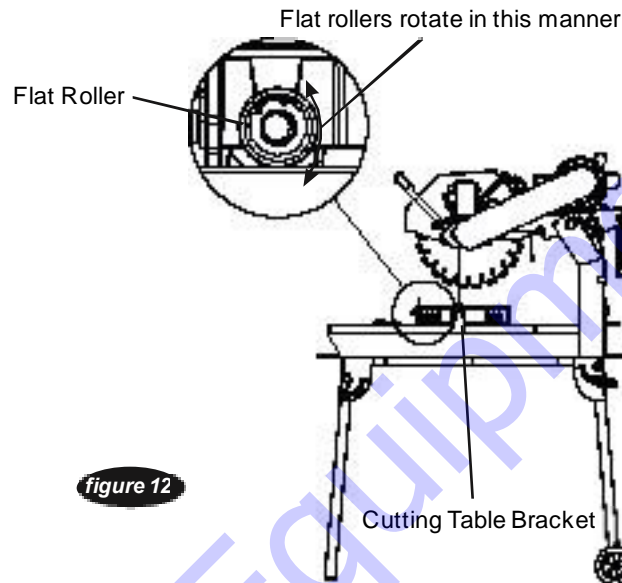

2. Hold the table against the guide rails. If the table is not level, locate which flat roller has a gap between the roller and rail.
3. After deciding which guide roller to adjust, lift the cutting table from the guide rails, turn it over and set it on top of the rails. Remove the inner nut for both guide rollers that need to be adjusted.
4. So the guide roller can be adjusted, slightly loosen the rollers bolt. Turn the table back over and mount it to the rails.
5. Using a wrench turn the guide roller towards the rail until the table is level.
6. After the table is level, place a rafter square on the table and slide it towards the blade (figure 13).

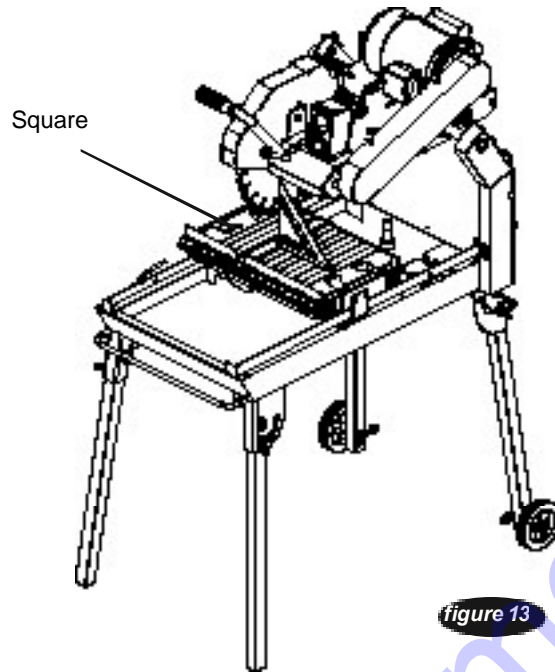

7. The square face closest to the blade should be parallel to the blade. If it is not, raise/lower both flat rollers until it is level.
8. The table should now be level and square with the blade. If it is not repeat previous steps 2 thru 7.
9. Mount the table to the guide rails and remember to reattach and tighten all hardware.

ELECTRICAL SPECIFICATIONS

	BSM 1402
Power	2 HP
Volts	115-120V
Amps	18.3A
Motor RPM	3420 RPM
Cycle	60 Hz
Phase	1

RECOMMENDATIONS

- ~ It is recommended that a 20 amp circuit be used while operating this saw. This will prevent any loss of power or interruption.
- ~ Always plug saw as close as possible to the power source while operating. This will allow you to receive optimum electricity.

Extension Cord Chart

⚠ WARNING:
To avoid permanent motor damage, you must use the correct extension cord. Never use more than one extension at a time. Follow the chart below for proper size.

Wire Gauge	Length of Cord
No. 12	25'
No. 10	50'
No. 8	75'

Electrical Wiring Diagram

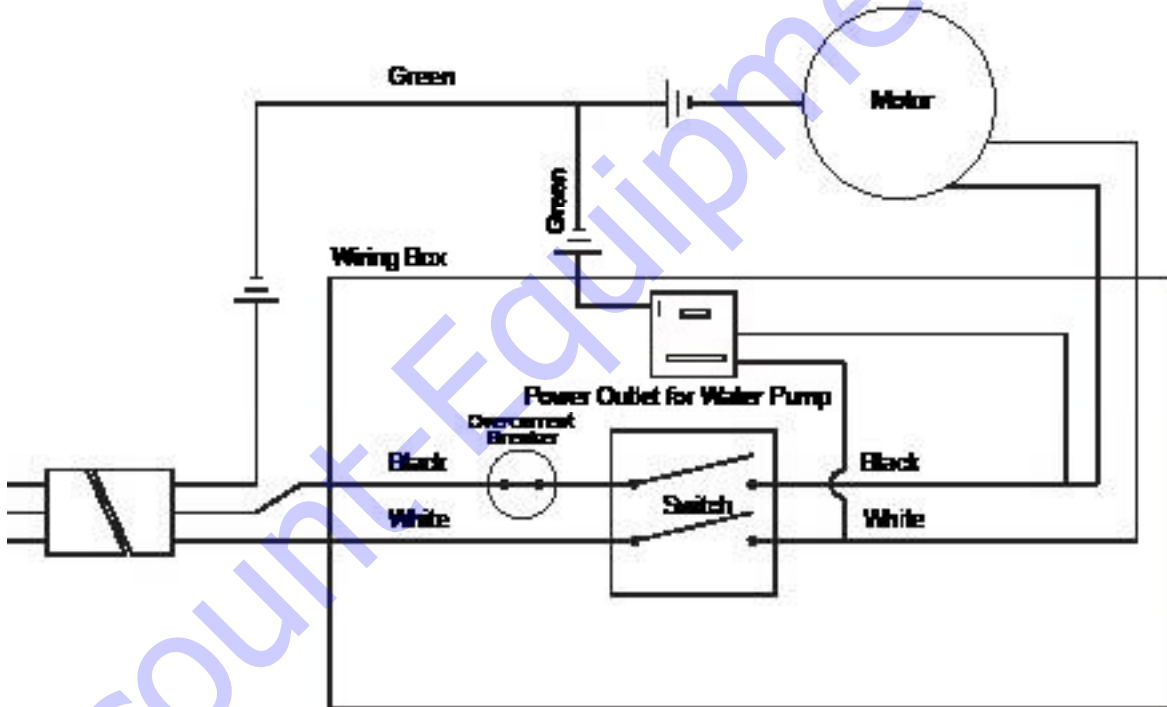

TROUBLESHOOTING

Problem	Possible Cause	Solution
Machine does not run when switched on	Power cord not properly fixed/plugged in	Check that the machine is properly connected to the power supply
	Power cord defective	Have the power cord checked, replace if necessary
	Main power switch defective	Have the main power switch checked and replace if necessary by a qualified electrician
	Loose electrical connection inside the electric system	Have the whole electric system of the machine checked by a qualified electrician
	Motor defective	Have the motor checked and replaced if necessary by a qualified technician
Motor stops (power cut out)	Too much pressure exerted while cutting	Exert less pressure when cutting
	Incorrect specification for saw blade	Use a saw blade which corresponds to the material being cut
	Saw has a defective electric system	Have the electric system of the saw checked by a qualified technician
Poor machine performance, little power	Power cord/extension cable too long or cable still wound up inside cable drum	Use a power cord/extension cable of the rated length, use a cable drum with cable fully extended
	Power network is insufficient	Observe the electrical ratings of the machine and connect it only to a power network which complies with these ratings

	Drive motor no longer runs at rated speed (RPM)	Have the motor checked by a qualified electrician and have it replaced if necessary
--	-------------------------------------------------	-------------------------------------------------------------------------------------

Problem	Possible Cause	Solution
Insufficient flow of cooling water or no cooling water at all	The pump draws air	Fill the container with water
	Filter clogged	Clean the filter of the pump
	Pump wheel of the immersion pump blocked by dirt	Disassemble the immersion pump and clean
Irregular run of the saw blade	Poor tension in the blade material	Return the saw blade to the manufacturer
Saw blade wobbles when running	Saw blade is damaged or bent	Have the saw blade aligned / flattened
		Clean the receiving flange
		Solder the diamond segments of the old blade onto another saw blade or use a new blade
	Flange of the saw blade is damaged	Replace the saw blade flange
	Shaft of the motor is bent	Replace the electric motor
Diamond segment becomes loose	Overheating of the saw blade; cooling water not sufficient	Have the diamond segment soldered on the blade again; ensure optimum flow of cooling water
Excessive wear	Wrong type of saw blade	Use harder saw blades

	Shaft of motor causes wobbling	Have bearings of the motor or the motor replaced
	Overheating	Ensure optimum flow of cooling water
Cracks in or near the diamond segment	Saw blade too hard	Use a softer blade
	Fixed flange is worn out	Replace the fixed flange
	Motor shaft bearing	Replace the bearing of the motor shaft

Problem	Possible Cause	Solution
Saw blade is blunt	Saw blade type is unsuitable for the material being cut	Use appropriate type of saw blade
	Saw blade type is unsuitable for the machine performance	
	Saw blade too hard	
	Diamond segments are blunt	Sharpen the diamond saw blade
Appearance of cut is not optimal	Poor tension in the blade material	Return the saw blade to the manufacturer
	Too much load placed on the saw blade	Use a suitable saw blade
	Diamond segments are blunt	Sharpen the saw blade
The center hole in the saw blade has become wider due to wear	The saw blade has slipped on the motor shaft when running	The arbor of the saw blade must be fitted with an appropriate adaptor ring

		Check the receiving flange and have it replaced if necessary
Saw blade shows blooming colors	Saw blade overheating due to a lack of cooling water	Ensure an optimum flow of cooling water
	Lateral friction when cutting	The material feed is too high; proceed more slowly
Grinding marks on the saw blade	Material is not being fed parallel to the saw blade	Ensure that the direction of feed is absolutely parallel to the saw blade
		Adjust the roller table or have it adjusted
	Poor tension in the blade material	Have the saw blade tensioned
	Too much load on the saw blade	The material feed is too high, proceed more slowly

Discount-Equipment.com