



WALK-BEHIND TROWELS

**B424 – B430 – BC436 – BC446 – B436 – B446 – MEGA-T B446
OWNER'S MANUAL**



www.Discount-Equipment.com

SAFETY PRECAUTIONS



DANGER

EXPLOSION HAZARD

Never operate the machine in an explosive atmosphere, near combustible materials, or where ventilation does not clear exhaust fumes.



WARNING

BURN HAZARD

Never come into contact with the engine or muffler when engine is operating or shortly after it is turned off. Serious burns may occur.



CAUTION

ROTATING HAZARD

Never place hands or feet inside safety guard rings. Serious injury will result from contact with rotating blades.



CAUTION

MOVING PARTS

Before starting the machine, ensure that all guards and safety devices are in place and functioning properly.



ATTENTION

READ OWNER'S MANUAL

Read and understand owner's manual before using this machine. Failure to follow operating instructions could result in serious injury or death.

Personal Protective Equipment (PPE)



Hearing Protection

Wear earplugs or ear muffs to protect hearing from potentially damaging noise levels



Eye Protection

Wear eye protection to protect eyes from blowing dust, splattering concrete, and other foreign objects



Safety Footwear

Wear safety footwear to protect feet from falling objects, compression and punctures or cuts from surrounding and below



Hand Protection

Protect exposed skin surfaces when working with fresh concrete to avoid skin irritation or chemical burns

TABLE OF CONTENTS

QUALITY ASSURANCE/ MACHINE BREAK IN	5
WALK-BEHIND TROWEL WARRANTY	6
ROUTINE SERVICE INTERVALS	7
ROUTINE SERVICE INTERVALS	8
OPERATING SAFETY PRECAUTIONS	9
SAFETY PRECAUTIONS	9
ASSEMBLY INSTRUCTIONS (B424, B430 EDGER)	10
ASSEMBLY INSTRUCTIONS (BC436, BC446, B436, B446, MEGA-T)	10
OPERATION INSTRUCTIONS	13
OPERATION (FLOATING)	13
OPERATION (FINISHING)	13
STARTING PROCEDURE: WARM CLIMATE	14
STARTING PROCEDURE: COLD CLIMATE	14
STOPPING PROCEDURE	14
LUBRICATION	14
STORAGE	15
MAINTENANCE	15
FOLDING HANDLE	16
TRANSPORTING	17
TROWEL ARM ADJUSTMENT FIXTURE	18
ADJUSTMENT PROCEDURE	18
TROWEL ARM ADJUSTMENT SCREW	19
TROUBLESHOOTING	20
TECHNICAL INFORMATION	22
B424 EDGER & B430 EDGER	22
B436 & B446 WALK-BEHIND TROWEL	22
DECLARATION OF CONFORMITY	23

QUALITY ASSURANCE/ MACHINE BREAK IN

The Bartell Walk-Behind Power Trowel is the product of extensive engineering development designed to give long life and unmatched performance. The Walk-Behind Power Trowels are Shipped Partially Assembled, and only require filling with fuel and a brief check of lubricant levels in preparation for operation.

You can help ensure that your Power Trowel will perform at top levels by observing a simple routing on first use. Consider that your new Power Trowel is like a new car. Just as you would break in a new car to the road or any new machine to the job, you should start gradually and build up to full use. Learn what your machine can do and how it will respond. Refer to the engine manufacturer's manual for run-in times. Full throttle and control may be used after this time period, as allowed by material. This will serve to further break in the machine on your specific application, as well as provide you with additional practice using the machine.

We thank you for the confidence you have placed in us by purchasing a Bartell Walk-Behind Trowel and wish you many years of satisfied use.

WALK-BEHIND TROWEL WARRANTY

All products sold by Bartell Morrison Inc. and Bartell Morrison (USA) LLC (the “Company”) are warranted against defects in materials and/or workmanship; excluding normal wear on wearing components and components covered by a separate original manufacturer’s warranty, for a period of 12 months (BC436, BC446) or 36 months (B424, B430, B436, B446, B446 Mega-T) from the date of sale to the original end user purchaser provided that certain conditions have been met.

Conditions

1. The equipment serial number has been registered with the Company or its approved dealers, distributors, representatives or agents.
 2. The equipment has been operated in an appropriate manner by qualified individuals.
 3. The equipment has been properly maintained as per the instructions included in the Owner’s Manual.
 4. All claims for warranty must be filed on proper forms and include the serial number of the equipment along with proof of purchase.
- Any evidence of failure to meet these conditions may result in a denial of the warranty claim.

Consideration of warranty claims will be at the sole discretion of the Company, or its authorized dealers, distributors, representatives or agents.

The Company may, at its discretion, request that the equipment to be considered for warranty be returned at the owner’s expense to an authorized repair facility for inspection.

Under this warranty we may, at our discretion, repair or replace a part or the whole of the defective component or equipment.

Our Warranty coverage is limited to the cost to repair or replace the defective portion of the equipment and a reasonable (as determined by the Company) amount of labour to conduct the repair or replacement. Under no circumstances shall the Company be liable for any additional or exceptional costs beyond the cost to repair or replace the defective portion of the equipment. The Company shall not be held accountable for; costs associated with travel to inspect or repair defective equipment, costs for transporting defective equipment to or from an authorized repair facility, costs incurred to repair or replace the defective equipment at any facility other than one authorized by the Company or ancillary damage caused by or as a result of the defective equipment.

Under no circumstances shall equipment be returned to the Company or its authorized dealers, distributors, representatives or agents without the approval of the Company as evidenced by a Returned Goods Number. To obtain a Returned Goods Number contact the factory or your authorized dealer, distributor, representative or agent.

This warranty is for the sole benefit of the original end user purchaser and is not transferable to any other company or person.

ROUTINE SERVICE INTERVALS

Routine Service Intervals		Each Use	After 1.5 months or 50	Each 3 months or 100 hrs	Each 6 months or 200 hrs	Each 9 months or 300 hrs	Each 12 months or 400 hrs
General Inspection:							
Guards	Check	0	0	0	0	0	0
Warning stickers	Check	0	0	0	0	0	0
Test run:	Check operation		0	0	0	0	0
Controls:							
Safety switch operation	Check	0	0	0	0	0	0
Pitch control	Check	0	0	0	0	0	0
	Lubricate		0	0	0	0	0
Drive Train:							
Clutch / Pulley	Check	0	0	0	0	0	0
Spider plate assembly	Check	0	0	0	0	0	0
	Grease (B436/446)	0	0	0	0	0	0
	Lubricate (B424/430)		0	0	0	0	0
V-Belt	Check	0	0	0	0	0	0
Blades	Check	0	0	0	0	0	0
Gearbox:							
Gearbox oil	Check Level	0					
	Change				0		0
Gearbox breathers	Check operation			0			
Engine:							
Engine oil (2)	Check Level	0					
	Change		0		0		0
Air Cleaner (2)	Check – Clean	0 (1)	0				
	Replace			0	0	0	0

- (1) Service more frequently in dusty areas
- (2) Refer to engine owner's manual for servicing instructions and a detailed maintenance schedule. Some items should be serviced by your servicing dealer, unless you have the proper tools and are mechanically proficient. Refer to the Honda shop manual for service procedures

ROUTINE SERVICE INTERVALS

Due to the nature and environment of use, Power Trowels could be exposed to severe operating conditions. Some general maintenance guidelines will extend the useful life of your trowel.

- The initial service for your power trowel should be performed after 25 hours of use, at which time your mechanic (or authorized repair shop) should complete all of the recommended checks in the schedule above.
- Regular service according to the schedule above will prolong the life of the Power Trowel and prevent expensive repairs.
- Keeping your Power Trowel clean and free from debris is the single most important regular maintenance operation, over and above the checks in the service schedule above, that can be performed. After each use your Power Trowel should be cleaned to remove any dust and debris from the undercarriage and surrounding components. Use of a power washer will make clean up quick and easy, especially if a non-stick coating was applied prior to use.
- In the Service Schedule above, items that should be checked, replaced or adjusted are indicated by “o” in the appropriate column. Not all Power Trowel models include the same features and options and as such not all service operations may have to be performed. For ease of recording place a checkmark (✓) through the “o” when the item is complete. If an item is not required or not completed place an “x” through the “o” in the box.
- All Power Trowels have governed engine speed of 3600 rpm. See engine manufacturer’s manual for exact specifications. Care should be used when making any adjustments to the Power Trowel not to change the governed speed.
- Failure to have your Power Trowel regularly serviced and properly maintained in accordance with the manufacturer’s instructions will lead to premature failure and void the warranty.

OPERATING SAFETY PRECAUTIONS

SAFETY PRECAUTIONS

- Always keep unauthorized, inexperienced, untrained people away from this machine.
- Rotating and moving parts will cause injury if contacted. Make sure guards are in place. Keep hands and feet away from moving parts.
- Fuel the machine only when the engine is stopped, using all necessary safety precautions.
- The engine must always be stopped before attempting any repair or adjustments. Ignition switch should be off.
- Be careful when working around pipes or ducts protruding from the floor or slab edges. If the trowel blades hit such obstacles, damage to the machine or possible operator injury may result.
- When starting the machine, do not exceed 1/3 throttle position. A higher setting may cause the centrifugal clutch to engage and the handle to rotate.
- Be careful not to come in contact with the muffler when the engine is hot, serious burns may result!
- Over time, the blades will form a sharp edge. Be careful when handling the old blades.

DANGER: Never operate the machine in an explosive atmosphere, near combustible materials or where ventilation does not clear exhaust fumes. Repair fuel leaks immediately. Refer to your engine owner's manual for more safety instructions.

ASSEMBLY INSTRUCTIONS (B424, B430 EDGER)

Folding handle version: Your new Bartell Edger Power Trowel has been shipped to you fully assembled. All you need to do is remove the locking pin, unfold the handle and re-insert the locking pin.

Rigid handle version:

Remove any shipping or packing materials. On Euro models, be sure to remove and discard the band securing the safety/stop switch on the handles. This serves only to facilitate shipping and is not intended to be a permanent feature.

When removing the machine from the carton, be careful to use the handles to lift the unit from the carton. NEVER LIFT THE MACHINE BY THE RING OR DISC. Filling the fuel tank and a brief check of lubricant levels in preparation for operation is required.

ASSEMBLY INSTRUCTIONS (BC436, BC446, B436, B446, MEGA-T)

Your new Bartell Walk-Behind Power Trowel has been shipped to you partially assembled. Filling the fuel tank and a brief check of lubricant levels in preparation for operation is required.

IMPORTANT: Before running machine, ensure that engine idles properly and that the safety-switch shuts off the engine.

To complete the assembly for all Bartell Walk-Behind trowels, the following instructions will be helpful.

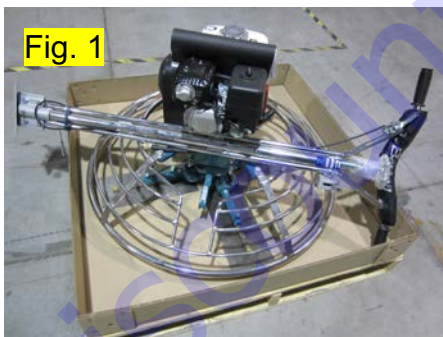

Step 1: Trowel shown with handle separate. (Fig. 1)



Step 2: Lay handle on ring to prepare for assembly. (Fig. 2 and 3)



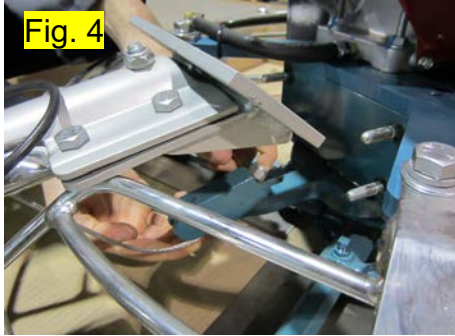

Fig. 4

Step 3: Install pitch control cable to yoke and install locknut loosely (Fig. 4). If needed, turn pitch control knob counter-clockwise until the stop screw is at the lowest position (Fig. 5).



Fig. 5

Step 4: Lift and install handle to position using the supplied four sets of lockwashers and nuts. Do not torque greater than 18ft-lb. At the yoke; tighten the locknut for pitch control cable (Fig. 6). If the cable is too loose or tight, the pitch control range position can be moved by changing the position of the stop screw (Fig. 5). The factory default is the middle position. Turn the pitch control knob completely clockwise and check for maximum pitch possible. This is possible when the clearance between the yoke and underside of the gearbox is enough to pass a business card through.

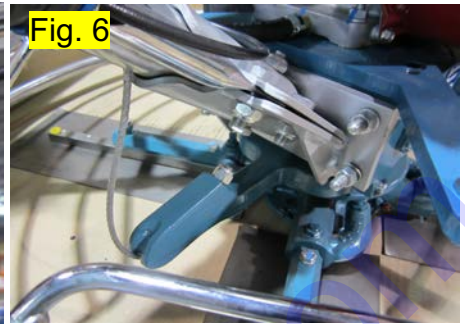

Fig. 6



Fig. 7

Step 5: Unwrap throttle control and engine safety shut-off wires to prepare for their assembly. (Fig. 7 and 8)

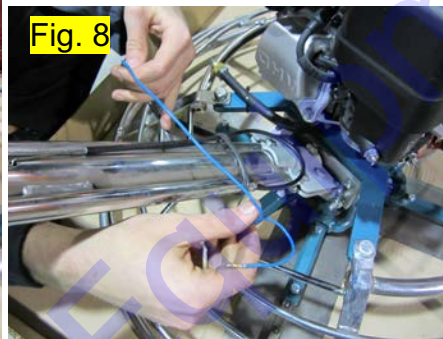

Fig. 8



Fig. 9

Step 6: Remove air filter cover and air filter. (Fig. 9)



Fig. 10

Step 7: Check for free moving engine throttle control lever and loosen pivot nut if necessary (Fig. 10)



Fig. 11

Step 8: Push handle throttle lever all the way forward for idle position (Fig. 11). If necessary, the tension screw can be adjusted for smooth operation while holding throttle position.

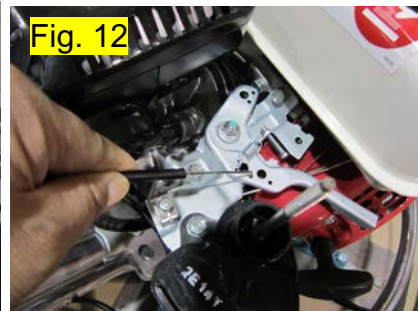
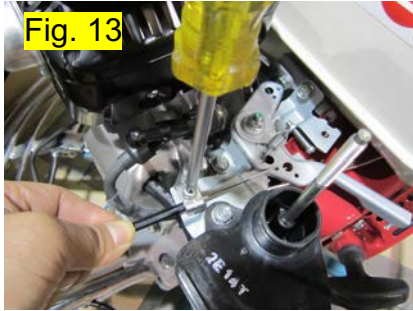
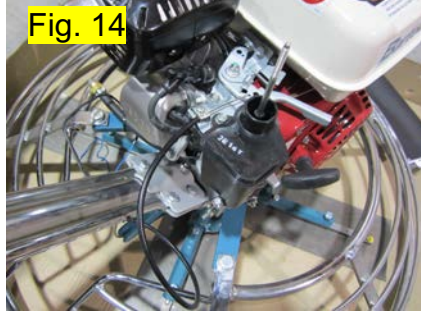

Fig. 12

Step 9: Install the throttle control wire into the throttle control lever. (Fig. 12)



Step 10: Secure the wire to the cable clamp while pushing with slight pressure forward. (Fig. 13)



Step 11: Check operation of throttle control lever. (Fig. 11 and 14)



Step 12: Reinstall air filter and cover (Fig. 15)

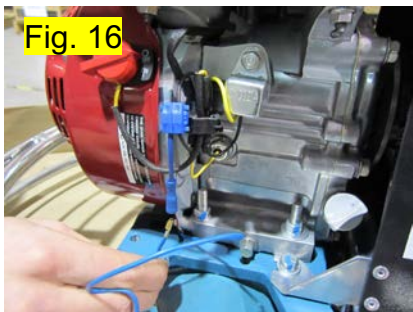

Step 13: Route engine safety shut-off wire around engine and install. There are two types that may be available with the machines. (Fig. 16 and 17)

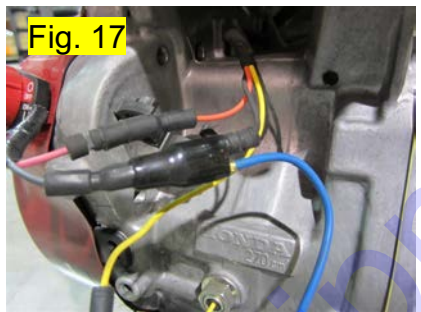

Step 14: Wrap and secure engine safety shut-off wire. (Fig. 18)

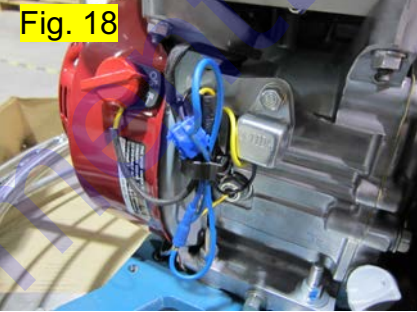

Step 15: Refer to Owner's Manual before operating the trowel.

Discount-Equipment.com

OPERATION INSTRUCTIONS

OPERATION (Floating)

When the slab has set sufficiently firm that the operator's footprint leaves a very slight depression on the surface of the slab, it is ready for the floating operation.

Guiding the machine on the slab is very simple, a slight upward lift of the handle causes the machine to travel to the left. Holding the handle in the neutral position, will slowly cause the machine to spin in one spot. Slight downward pressure on the handle causes the machine to travel to the right. Best results are obtained by covering approximately 4" on each turn. In other words, let the machine move right or left, backwards or forwards, approximately 4" with each revolution of the trowels. To fill a hole or cut down a hump, move the unit back and forth over the problem area.

Under normal operating conditions the machine should cover as much as 1000 sq. ft. in about 15 minutes. It is recommended that a slight tension on the trowel control cable, (but *not* a definite tilt), during the floating operation will cause the machine to operate much smoother. After the floated slab has set sufficiently, it is ready for the finishing operation.

CAUTION: Do not let the machine stand in one spot on the soft cement. Lift from the slab when the floating operation is complete.

OPERATION (Finishing)

When starting the finishing operation, never set the trowels up over 1/4" pitch. This is important. Guiding the machine on the slab is very simple, a slight upward lift of the handle causes the machine to travel to the left. Holding the handle in the neutral position, will slowly cause the machine to spin in one spot. Slight downward pressure on the handle causes the machine to travel to the right. Best results are obtained by covering approximately 4" on each turn. In other words, let the machine move right or left, backwards or forwards, approximately 4" with each revolution of the trowels. To fill a hole or cut down a hump, move the unit back and forth over the problem area.

After the first pass over the slab, the waiting time between operations is determined in the same manner as if you were hand troweling. To repeat; the entire application and action of the troweling machine in regard to getting on the slab, and the correct pitch of the trowels, is determined in the same manner as would be used by a cement finisher when troweling by hand.

STARTING PROCEDURE: WARM CLIMATE

Open fuel valve on gas tank. Set throttle lever to “Fast” idle position, set choke to closed position, start engine. Open choke slightly to prevent flooding. Move to “Open” or “Run” position when engine is warm, increase throttle to maximum operation position (3600 rpm).

STARTING PROCEDURE: COLD CLIMATE

Follow same procedure as above but allow longer warm-up period – 3 to 5 minutes. In cold weather, oil is much heavier to move and requires more time to work its way into the moving parts. If maximum power is not attained, allow further warm-up time. Fill fuel tank with clean gasoline, use safety approved gas containers. DO NOT MIX OIL WITH GASOLINE – USE UNLEADED GAS ONLY.

STOPPING PROCEDURE

1. Throttle engine down
2. Turn off stop switch

LUBRICATION

1. ENGINE OIL

The long life and successful operation of any piece of machinery is dependent on frequent and thorough lubrication. Before using the trowel, always check your engine for oil. Use proper engine oil as recommended in the engine manufacturer's manual. Fill crankcase to levels as recommended.

ENGINE OIL SPECIFICATIONS

All seasons: SAE 10W-30

2. SPIDER PLATE - GREASE

There are 4 (four) grease fittings on the spider plate, each must be greased daily. THE SPIDER PLATE MUST BE GREASED EVERY TIME MACHINE IS USED.

3. SPIDER PLATE – OIL BATH (B424/B430 Edger only)

The trowel arm on the spider plate does not require lubrication to be added every use. However, the oil in the oil bath spider plate should be checked periodically and topped up or changed if necessary.

4. HOW TO CHANGE OIL IN THE OIL BATH SPIDER PLATE (B424/B430 Edger only)

Step 1. First remove the set screw that holds the trowel arm into the spider plate

Step 2. Add oil through the set screw hole. Very little oil is needed.

Step 3. While rotating the trowel arm throughout its pitch direction, pull the trowel arm about half to three quarters of the way out of the spider plate. This should be done about half dozen times. Doing this releases any pressure that may have built up in the chamber that holds the arm and the oil. The pressure will release through the oil grooves and through the vacant bolt hole. Add oil if necessary.

Step 4. Push the trowel arm back into its proper location and re-install the set screw. The trowel arm should move freely.

Step 5. Steps 1 to 4 should be repeated for remaining trowel arms.

NOTE: THE LUBRICATION SYSTEM SHOULD BE CHECKED AT LEAST ONCE PER MONTH TO ENSURE THAT THE UNIT IS FUNCTIONING PROPERLY.

5. GEARBOX (Except B424/B430 Edger)

Check the oil level sight plug on the gearbox daily to ensure the oil is half way on the site glass. Top up with Agma 8 compounded gear oil only. Gearbox capacity 16 oz. to 19 oz. (473ml. To 562ml.) Example: Esso/Exxon Cyclesstic TK680.

6. TO CHANGE GEARBOX OIL (Except B424/B430 Edger)

Place a pan beneath the drain plug to catch the oil. Remove the drain plug and the filler plug from the gearbox. After the oil has drained completely, replace the drain plug and tighten. Fill gearbox through the filler plug with 16 oz. to 19 oz. (473ml to 526ml) of Agma 8 compound gear oil. Replace the filler and tighten.

7. GEARBOX (B424/B430 Edger)

Check for oil leaks around gearbox. If necessary, remove drain plug from back of gearbox to drain and refill with 10.1 oz. (0.3 L) of Shell Tivela Compound A or similar.

STORAGE

The following steps should be taken to prepare your walk-behind trowel for extended storage.

1. Clean the exterior surfaces of the trowel.
2. Close fuel shut off valve.
3. Siphon excess gasoline from tank.
4. Start engine until it stops from lack of fuel. This will use up all the fuel in the carburetor and prevent formation of deposits due to evaporation of fuel.
5. Store the unit in an upright position in a cool, dry, well ventilated area.
6. Refer to the engine manual for more information.

MAINTENANCE

Maintaining your Walk-Behind Power Trowel will ensure long life to the machine and its components.

AIR CLEANER - Keep air filter clean at all times. Refer to engine manual.

LUBRICATION – Check engine oil regularly. Use proper engine oil as recommended. See previous chart. Fill crankcase to levels as recommended in manufacture's engine manual.

SPARK PLUG – Check and clean spark plugs regularly. A fouled or dirty spark plug causes hard starting and poor engine performance. Set spark plug gap to recommended clearance. Refer to engine manual.

BELT TENSION – IMPORTANT! When the engine is switched off, and the machine has stopped, the normal belt play should be loose. This is due to the clutch type. When the machine is running at full throttle, the clutch will close in, which tightens the belt causing the gearbox to engage. When adjusting the belt make sure that the clutch is in alignment with the follower pulley. Secure belt guard. Tighten all engine mount bolts, and tighten lock nuts.

FOLDING HANDLE

FOLDING PROCEDURE

To avoid damage to the folding handle or the pitch cable please follow the instructions below.

1. Turn the fine pitch knob counter clockwise to remove pitch from the blades.
2. Once the blades are flat, keep turning the knob counter clockwise until the stop screw bottoms out in the slot. (see Fig 19)
3. Now that the cable has enough slack, remove the locking screw by turning it counter clockwise and fold the handle slowly. Damage may occur if handle is dropped into folding position.
4. Reinsert the locking screw when the handle is in the folded position, turn the locking screw clockwise to secure in place. (See Fig 20)
5. Your handle is now folded and ready for transportation or storage.

UNFOLDING PROCEDURE

6. Follow the folding procedure but in reverse to return the handle into operating position.

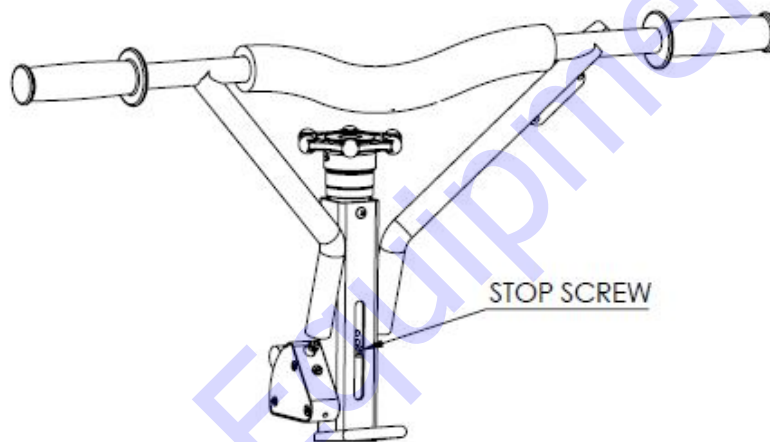

Fig 19

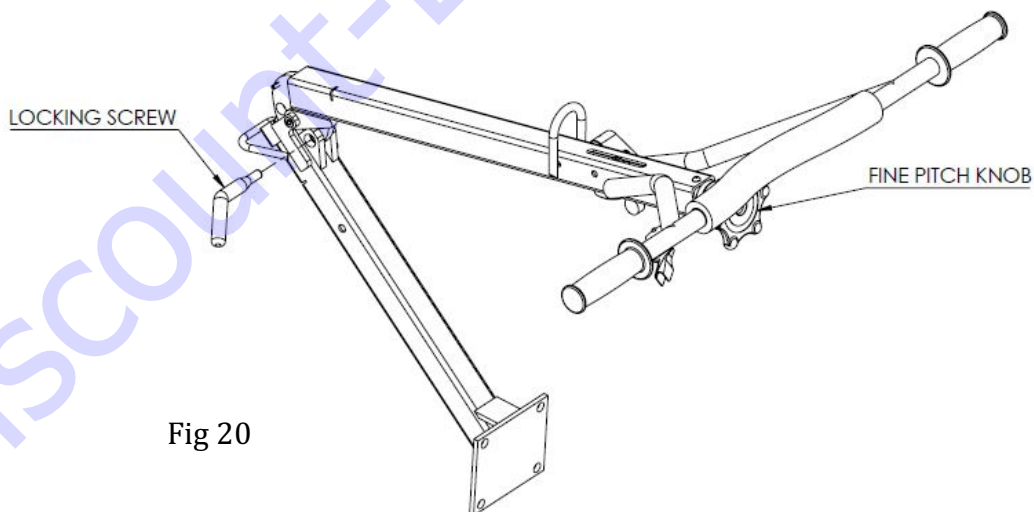

Fig 20

IMPORTANT: IF THERE IS NOT ENOUGH SLACK IN THE PITCH CABLE, THE CABLE WILL GET DAMAGED WHEN FOLDING. MAKE SURE THERE IS AS MUCH SLACK AS POSSIBLE BY TURNING THE PITCH KNOB COUNTER CLOCKWISE COMPLETELY.

TRANSPORTING

When transporting the trowel by human effort (carrying, sliding, etc.), always keep the handle folded (if equipped) and the blades fully un-pitched to prevent damage to the pitch control system.

When lifting from above via a crane, forklift, etc. always use the hoist hook. The hoist hook is an optional feature that can be mounted to the engine or a feature built in to the folding handles.

Recommended Tie Down Points

Edger Trowel w/folding handle – Always make sure handle is folded and lock pin is installed while transporting. The front carry handle and the rear carry handle can be used as tie down points.

Edger Trowel w/rigid handle – The front carry handle and base of the handle can be used as tie down points. Wrap the tie down strap around the base of the handle for best results.

B436 w/folding handle – Always make sure handle is folded and lock pin is installed while transporting. The top ring of the guard ring and the rear carry handle can be used as tie down points.

B436/446 w/rigid handle – Use the top ring of the guard ring as a tie down point. Use 2-4 tie downs space evenly apart for best results

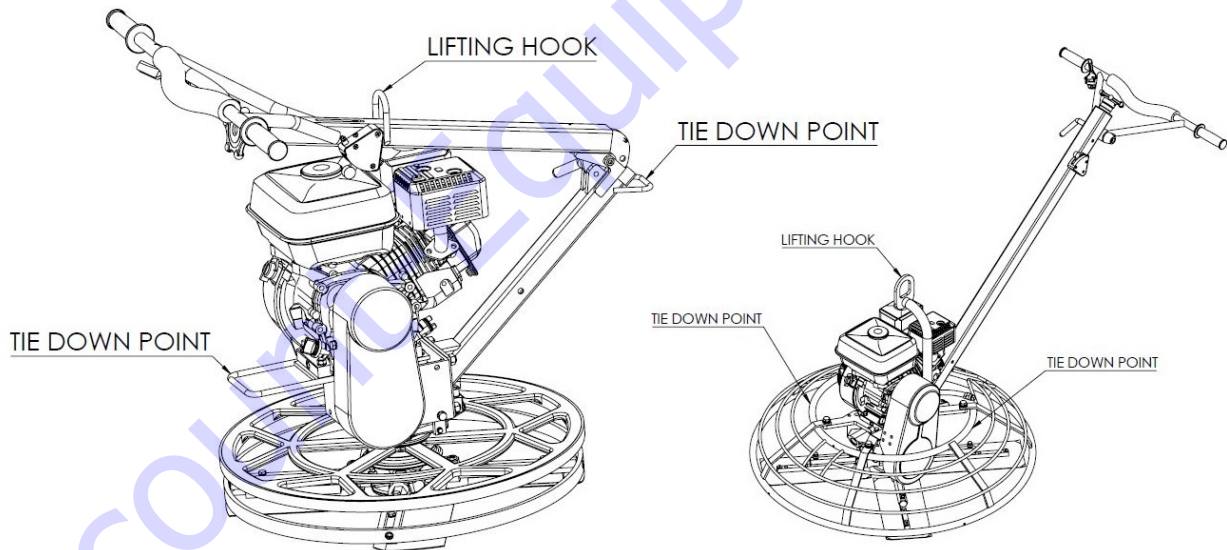

Trowel recommended tie down locations and over head lifting points

EDGER TROWEL CAUTION: Never lift the trowel by the rotating ring; use the hoist hook or handle provided on the trowel.

ALL TROWEL CAUTION: Remove the float disc when lifting machine more than 100cm (40"). The floating disc is loosely secure, so it may fall off.

TROWEL ARM ADJUSTMENT FIXTURE

- PART #20801
Ex: Unit 36" (B436)
- 1) Trowel arm
 - 2) Lift lever
 - 3) Jam nut
 - 4) Set screw
 - 5) Block top
 - 6) Bolt
 - 7) Jam nut
 - 8) Carriage bolt
 - 9) Adjustment bar
 - 10) Bolt

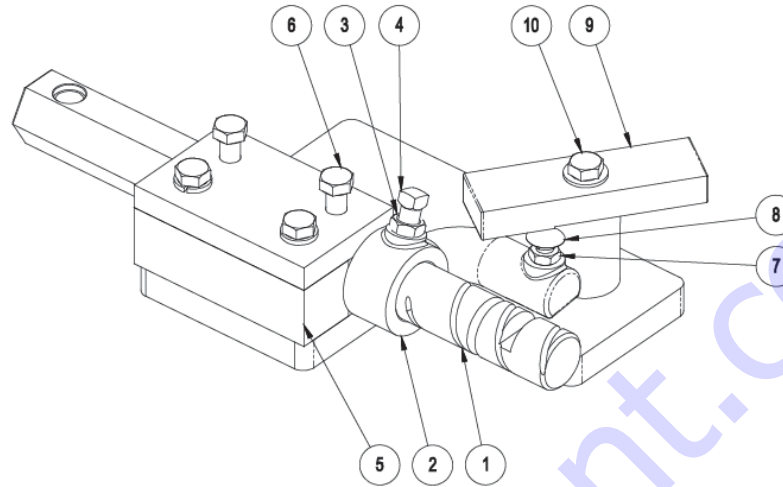

The trowel arm adjustment fixture (20801) is reversible. By rotating the arm clamping fixture and the ring bolt, both left hand and right hand trowel arms may be adjusted. Before attempting adjustment, determine whether the trowel arm is right handed or left handed. When adjusting left hand trowel arms use the side of the fixture marked "L". When adjusting right hand trowels arms use the opposite side. The adjustment bar will be set on "36" for the Walk-behind trowel arm.

ADJUSTMENT PROCEDURE

1. Remove all trowel arm assemblies (1 & 2 arm and attached lift lever) from suspected maladjusted spider plate.
2. Remove lift lever (2) from trowel arm (1) by first loosening jam nut (3) then square head screw (4). If upon inspection (method left to discretion of serviceman) any trowel arm (1) is found to be in a bent condition, it must either be brought back to its original straight condition (method left to the serviceman's discretion) or replaced with new part.
3. Replace lift levers (2) on new or straightened arms (1) by reversing procedure as described above.
4. Place trowel arm assembly (1 and 2) in fixture (5) with lift lever (2) butting up against fixture. Clamp in place with bolts (6).
5. Loosen locknut (7) and screw carriage bolt (8) down to full depth allowable. This will provide for ample clearance to swing precision ground adjustment bar (9) over head of carriage bolt. Adjustment bar (9) is stamped for appropriate size of machine. Swing appropriate side directly over carriage bolt (8) and secure in place with bolt (10).
6. Adjust carriage bolt (8) upwards until contact is made with adjustment bar (9); holding carriage bolt in position with one wrench, tighten locknut (7) to secure in position with second wrench.
7. This same procedure is to be followed with ALL arms from spider plate assembly, and will ensure correct and exact adjustment.

TROWEL ARM ADJUSTMENT SCREW

The trowel arm adjustment screw is to be used for field adjustment of blade level, in the event of a damaged trowel arm, to enable completion of the job. At the end of the job repairs should be made to eliminate the damage. When assembling trowel blades to trowel arms, the adjustment screw should NEVER protrude below the under-side surface of a trowel arm.

If the adjustment screw is not flush with the underside of the trowel arm, then this will cause the power trowel to bounce and vibrate especially at high speed. This will also cause the trowel blades to leave an uneven finish to the concrete due to the blades not being level to one another.

Make certain that the adjusting screw is held firmly in place while tightening the bolt which secures the blade to the trowel arm.

Discount-Equipment.com

TROUBLESHOOTING

WON'T START

- Throttle fully open
- Hand lever wire broken
- No gas
- Dirty gas
- Gas filter plugged
- Gas line plugged
- Hole in gas line
- Gas supply valve turned off
- Dead-man safety switch
- Safety switch wire or connectors not making good contact
- Other engine problems (Refer to engine manual)

STARTS BUT NO HIGH SPEED

- Engine problems
- Throttle cable broken or seized
- Throttle lever and connectors loose or out of adjustment
- Clutch shoes worn

STARTS AT HIGH SPEED, WON'T SLOW DOWN

- Same as above

ENGINE WON'T STOP

- Safety switch, wire or connectors not making good contact

ENGINE STARTS BUT WON'T TURN TROWELS AT ANY SPEED

- Clutch seized
- No weights or broken clutch
- Wrong belt
- Broken or missing key
 - o Clutch
 - o Pulley
 - o Worm gear (countershaft)
 - o Main gear
 - o Spider plate
- Gearbox seized

TROWELS TURN, ENGINE AT IDLE

- Idle too fast
- Belt too tight
- Clutch seized
- Pulley out of alignment

TROWELS BLADES WEARING UNEVENLY

- Spider plate seized
- Arms bent
- Adjusting screws (carriage bolts) incorrectly set

MACHINE JUMPS ON FLOOR

- Concrete hardened on bottom of spider plate
- Trowels unevenly worn
- Spider plate seized
- Spider plate loose
- Trowel arms bent
- Adjusting screws (carriage bolts) incorrectly set use spider plate adjustment jig (pg,13)
- Main shaft bent

PITCH CONTROLS WILL NOT OPERATE BLADES

- Cable broken or out of adjustment
- Slot screw missing (under-side of handle)
- Spider plate seized
- Pressure plate and/or yoke arm broken or badly worn
- Hand crank adjuster malfunctioning

BELT WEARING RAPIDLY

- Belt adjusted improperly
- Pulley out of alignment
- Wrong belt/defective belt
- Clutch sticking
- Gearbox seizing

OIL LEAKS

- Top of gearbox
 - o Engine leaks
 - o Relief valve broken
 - o Too much oil in gearbox
 - o Set screw missing in cover
- Between end cap and gearbox (recoil side)
 - o "O" ring damaged
 - o End cap not tight
- At main shaft or countershaft
 - o Relief valve seized
 - o Shaft and/or seal worn

TROWEL BLADES WILL NOT TURN

- Yoke arm broken
- Key sheared

SPIDER PLATE HARD TO GREASE

- Fittings plugged
- Cement in grease grooves of arms
- Grease fittings too tight

SPECIFICATIONS

Model	Path	Power Source (gas option)	Float Blade Size	Finish Blade Size	Combination Blade Size	Float Pan	Operating Weight
B424 (Edger)	24" (60cm)	Honda GX160	N/A	4.75" x 9" (12cm x 23cm)	N/A	24" (60cm)	Up to 110lbs (50kg)
B430 (Edger)	30" (76cm)	Honda GX160	10" x 30" (25cm x 28cm)	6" x 10.5" (15cm x 26cm)	6" x 10" (15cm x 25cm)	30" (76cm)	Up to 145lbs (66kg)
BC436	36" (91cm)	Honda GX160 Honda GX270	10" x 14" (25cm x 36cm)	6" x 14" (15cm x 36cm)	8" x 14" (20cm x 36cm)	38.5" (98cm)	Up to 195lbs (88kg)
BC446	46" (120cm)	Honda GX270 Honda GX340 Honda GX390	10" x 18" (25cm x 46cm)	6" x 18" (15cm x 46cm)	8" x 18" (20cm x 46cm)	48.5" (123cm)	Up to 255lbs (115kg)
B436	36" (91cm)	Honda GX160 Honda GX270	10" x 14" (25cm x 36cm)	6" x 14" (15cm x 36cm)	8" x 14" (20cm x 36cm)	38.5" (98cm)	Up to 195lbs (88kg)
B446	46" (120cm)	Honda GX270 Honda GX340 Honda GX390	10" x 18" (25cm x 46cm)	6" x 18" (15cm x 46cm)	8" x 18" (20cm x 46cm)	48.5" (123cm)	Up to 255lbs (115kg)
Mega-T B446	46" (120cm)	Honda GX340 Honda GX390	10" x 18" (25cm x 46cm)	6" x 18" (15cm x 46cm)	8" x 18" (20cm x 46cm)	48.5" (123cm)	Up to 285lbs (129kg)

TECHNICAL INFORMATION

B424 Edger & B430 Edger

Blade Speed (RPM) Engine Speed (RPM)	70 min – 125 max 3600
Clutch Type Variable Speed	Centrifugal Yes
Gearbox Oil Gearbox Oil Capacity Engine Fuel Engine Oil Alert Cooling Starting	Shell Tivela Compound A or similar type 10.1 oz. (0.3 L.) Gasoline – Unleaded Yes Air Recoil Starter - Manual
Safety Switch Fuel Capacity (approximately) Running Time (approximately)	Yes GX160: 0.8 Gal. (3.1 L) 2 ½ - 3 hours
Number of Blades	4
Average acoustic power (dB) Average acoustic pressure (dB) Acoustic pressure on operator (dB) Vibration value on the handle (aw)	103.2 88.8 89.1 7.0
Options	Hoist Hook, Folding Handle

B436 & B446 Walk-Behind Trowel

Blade Speed (RPM) Engine Speed (RPM)	120-140; 20-180 (Mega-T) 3600
Clutch Type Variable Speed	Centrifugal; CVT (Mega-T) Yes
Gearbox Oil Gearbox Oil Capacity Engine Fuel Engine Oil Alert Cooling Starting	Agma 8 compounded gear oil 16 oz. (473 ml), 19 oz. (562 ml) Gasoline – Unleaded Yes Air Recoil Starter - Manual
Safety Switch Fuel Capacity Running Time (approximately)	Yes GX160: 0.8 Gal. (3.1 L); GX270: 1.4 Gal (5.3 L); GX340, GX390: 1.6 Gal (6.1 L) 2 ½ - 3 hours
Number of Blades	4
Engine Acoustic Power Lwa (dB) Engine Acoustic Pressure Lpa (Db) Level of Vibration Vibration value on the handle	97-103 82-86 1.1-1.5 7.0 aw
Options	Folding Handle (B436), Easy-Pitch Lever, Hoist Hook

This Page Intentionally Left Blank

Discount-Equipment.com