



# GREEN CONCRETE SAW

SG10

OWNER'S MANUAL







Doc. # OI-B19053  
Orig. Rel. – 12/2017  
Curr Rev. - 00

Discount-Equipment.com

REV.	DATE	DESCRIPTION	APPROVED BY:
00	12/2017	Initial Release of New Format	AN

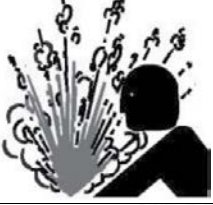
Discount-Equipment.com

**SAFETY PRECAUTIONS**

	<p><b>DANGER</b> <b>EXPLOSION HAZARD</b></p> <p>Never operate the machine in an explosive atmosphere, near combustible materials, or where ventilation does not clear exhaust fumes.</p>
	<p><b>WARNING</b> <b>BURN HAZARD</b></p> <p>Never come into contact with the engine or muffler when engine is operating or shortly after it is turned off. Serious burns may occur.</p>
	<p><b>CAUTION</b> <b>ROTATING HAZARD</b></p> <p>Never place hands or feet inside safety guard rings. Serious injury will result from contact with rotating blades.</p>
	<p><b>CAUTION</b> <b>MOVING PARTS</b></p> <p>Before starting the machine, ensure that all guards and safety devices are in place and functioning properly.</p>
	<p><b>ATTENTION</b> <b>READ OWNER'S MANUAL</b></p> <p>Read and understand owner's manual before using this machine. Failure to follow operating instructions could result in serious injury or death.</p>

Discount-Equipment.com

## TABLE OF CONTENTS

<b>WARRANTY INFORMATION – SG10</b>	<b>5</b>
<b>SAFETY INFORMATION – SG10</b>	<b>6</b>
SAFETY PRECAUTIONS:	6
OPERATING SAFETY	6
OPERATING SAFETY CONTINUED:	7
BLADE SAFETY	9
TRANSPORTATION SAFETY	9
SERVICE SAFETY	10
<b>OPERATION SG10</b>	<b>11</b>
APPLICATION	11
OPERATING PRINCIPLE	11
DELIVERY CHECKS	11
APPLICATION	12
BLADE PLACEMENT	13
OPERATION	14
CONTROLS AND COMPONENTS	15
<b>MAINTENANCE SG10</b>	<b>16</b>
BLADE REMOVAL AND REPLACEMENT	16
BLADE GUARD CHECK	16
V-BELT ALIGNMENT AND TENSIONING	17
<b>TROUBLESHOOTING SG10</b>	<b>18</b>
BLADE TROUBLESHOOTING	18
BLADE TROUBLESHOOTING CONTINUED:	19
ENGINE TROUBLESHOOTING	20
ENGINE TROUBLESHOOTING CONTINUED:	21
<b>TECHNICAL DATA SG10</b>	<b>22</b>
<b>SG10 ASSEMBLY DIAGRAM</b>	<b>ERROR! BOOKMARK NOT DEFINED.</b>
<b>PARTS LIST: SG10</b>	<b>ERROR! BOOKMARK NOT DEFINED.</b>
<b>DECLARATION OF CONFORMITY</b>	<b>24</b>

## **WARRANTY INFORMATION – SG10**

All products sold by Bartell Morrison Inc. and Bartell Morrison (USA) LLC (the “Company”) are warranted against defects in materials and/or workmanship; excluding the normal wear on wearing components covered by a separate original manufacturer’s warranty, for a period of 12 months to the original end user purchaser provided that certain conditions have been met.

Conditions:

1. The equipment serial number has been registered with the Company or its approved dealers, distributors, and representatives or agents.
2. The equipment has been operated in an appropriate manner by qualified individuals.
3. The equipment has been properly maintained as per the instructions included in the Owner’s Manual.
4. All claims for warranty must be filed on proper forms and include the serial number of the equipment along with proof of purchase.

Any evidence of failure to meet these conditions may result in a denial of the warranty claim.

Consideration of warranty claims will be at the sole discretion of the Company, or its authorized dealers, distributors, representatives or agents.

The Company may, at its discretion, request that the equipment to be considered for warranty be returned at the owner’s expense to an authorized repair facility for inspection.

Under this warranty we may, at our discretion, replace the defective portion of the equipment and a reasonable (as determined by the Company) amount of labour to conduct the repair or replacement.

Under no circumstances shall the Company be liable for any additional or exceptional costs beyond the cost to repair or replace the defective portion of the equipment. The Company shall not be held accountable for; costs associated with travel to inspect or repair defective equipment, cost for transporting equipment at any facility other than one authorized by the Company or ancillary damage caused by or as a result of defective equipment.

Under no circumstances shall equipment be returned to the Company or its authorized dealers, distributors, representatives, or agents without the approval of the Company as evidence by a Returned Goods Number. To obtain a Returned Goods Number contact the factory or your authorized dealer, distributor, representative or agent.

This warranty is for the sole benefit of the original end user purchaser and is not transferrable to any other company or person.

## **SAFETY INFORMATION – SG10**

### **Safety Precautions:**

Before using this equipment, study the entire owner's manual to become familiar with its operation. Do not allow untrained or unauthorized personnel, especially children, to operate this equipment. Use only factory authorized parts for service.

This manual contains DANGER, WARNING, CAUTION callouts which must be followed to reduce the possibility of personal injury, damage to the equipment, or improper service.

Obey all safety messages that follow to avoid possible injury or death. DANGER indicates a hazardous situation which, if not avoided, will result in death or serious injury. WARNING indicates a hazardous situation which, if not avoided, could result in death or serious injury. CAUTION indicates a hazardous situation which, if not avoided, could result in minor or moderate injury.

### **Operating Safety**

Failure to follow instructions in this manual may lead to serious injury or even death! This equipment is to be operated by trained and qualified personnel only. This equipment is for industrial use only. The following safety guidelines should always be used when operating this concrete saw:

Do not operate or service this equipment before reading the entire manual. This equipment should not be operated by persons under 18 years of age.

Never operate this equipment without proper protective clothing, shatterproof glasses, steel-toed boots and other protective devices required by the job.

Never operate this equipment when not feeling well due to fatigue, illness or taking medicine.

Never operate this equipment under the influence of drugs or alcohol.

Never use accessories or attachments, which are not recommended by Bartell Morrison for this equipment. Damage to the equipment and/or injury to user may result. The manufacturer does not assume responsibility for any accident due to equipment modifications.

Whenever necessary, replace nameplate, operation and safety decals when they become difficult to read.

Always check the machine for loosened threads or bolts before starting.

Never touch the hot exhaust manifold, muffler or cylinder. Allow these parts to cool before servicing engine or saw.

### **Operating Safety continued:**

Allow the engine to cool before adding fuel or performing service and maintenance functions. Contact with hot components can cause serious burns.

The engine section of this saw requires an adequate free flow of cooling air. Never operate the saw in any enclosed or narrow area where free flow of the air is restricted. If the air flow is restricted it will cause serious damage to the saw or engine and may cause injury to people.

Remember the saw's engine gives off deadly carbon monoxide gas.

Always refuel in a well-ventilated area, away from sparks and open flames.

Always use extreme caution when working with flammable liquids. When refueling, stop the engine and allow it to cool. Do not smoke around or near the machine. Fire or explosion could result from fuel vapors, or if fuel is spilled on a hot engine.

Never operate the saw in an explosive atmosphere or near combustible materials. An explosion or fire could result causing severe bodily harm or even death.

Topping-off to the fuel filler port is dangerous, as it tends to spill. Never use fuel as a cleaning agent.

Always read, understand, and follow procedures in operator's Manual before attempting to operate equipment.

Always be sure to operator is familiar with proper safety precautions and operating techniques before using the saw.

Stop the engine when leaving the saw unattended.

Block the unit when leaving or when using on a slope.

Maintain this equipment in a safe operating condition at all times.

Always stop the engine before service, adding fuel and oil.

Never run engine without air filter. Severe engine damage may occur. Always service air cleaner frequently to prevent carburetor malfunction.

Always store equipment properly when it is not being used. Equipment should be stored in a clean, dry location out of the reach of children.



Never operate this saw in areas that contain combustible material or fumes. Fire and/or explosions may result from errant sparks from the equipment.

Discount-Equipment.com

## **Blade Safety**

Use appropriate steel centered diamond blades manufactured for use on concrete saws.

Always inspect diamond blades before each use. The blade should exhibit no cracks, dings, or flaws in the steel centered core and/or rim. Center (arbor) hole must be undamaged and true. Examine blade flanges for damage, excessive wear and cleanliness before mounting blade. Blade should fit snug on the shaft and against the inside/outside blade flanges.

Ensure that the blade is marked with an operating speed greater than the blade shaft speed of the saw.

Only cut the material that is specified by the diamond blade. Read the specifications of the diamond blade to ensure the proper tool has been matched to the material being cut.

Always keep blade guards in place. Exposure of the diamond blade must not exceed 180 degrees.

Ensure that the diamond blade does not come into contact with ground or surface during transportation. Do not drop the diamond blade on ground or surface.

The engine governor is designed to permit maximum engine speed in a no-load condition. Speeds that exceed this limit may cause the diamond blade to exceed the maximum safe allowable speed.

Ensure that the blade is mounted for proper operating direction.

## **Transportation Safety**

Use the lifting bail and appropriate lifting equipment to ensure the safe movement of the saw.

Do not use the handle bars and/or front pointer as lifting points.

Never tow the saw behind a vehicle.

Ensure that both pointer bars are positioned appropriately to minimize their exposure during transportation.

Safeguard against extreme saw attitudes relative to level. Engines tipped to extreme angles may cause oil to gravitate into the cylinder head making the engine difficult to start.

Never transport the saw with the blade mounted.

## **Service Safety**

Never lubricate components or attempt service on a running machine.

Always allow the machine a proper amount of time to cool before servicing.

Keep the machinery in running condition.

Fix damage to the machine immediately and always replace broken parts.

Dispose of hazardous waste properly. Examples of potentially hazardous waste are used motor oil, fuel and fuel filters.

Do not use food or plastic containers to dispose of hazardous waste.

Discount-Equipment.com

## Operation SG10

### **Application**

This equipment is designed for dry sawing of concrete slabs utilizing diamond blades. The equipment has been engineered for general and industrial flat sawing applications that include: Joint Sawing of Green Concrete, Decorative Sawing in Cured Concrete, Light Demolition Sawing and V Groove Beveling. The simple and compact nature of the machine makes it a perfect sawing tool for one person to operate and transport. The saw combines innovative features, top quality components, and a committed attention to state-of-the-art manufacturing.

### **Operating Principle**

The following instructions were compiled to provide you information on how to obtain long and trouble-free use of the unit. Periodic maintenance of this unit is essential. Read the manual in its entirety and follow the instructions carefully. Failure to do so may injure yourself or a bystander.

#### **Starting Procedure - WARM CLIMATE:**

Open fuel valve on gas tank. Set throttle lever to "Fast" idle position, set choke to closed position, start engine. Open choke slightly to prevent flooding. Move to "Open" or "Run" position when engine is warm, increase throttle.

#### **Starting Procedure - COLD CLIMATE:**

Follow same procedure as above but allow longer warm-up period – 3 to 5 minutes. In cold weather, oil is much heavier to move and requires more time to work its way into the moving parts. If maximum power is not attained, allow further warm-up time. Fill fuel tank with clean gasoline, use safety approved gas containers. **Do not mix oil with gasoline – use unleaded gas only.**

#### **Shutdown Procedure:**

1. Throttle engine down.
2. Depress or turn off stop switch.

#### **Delivery Checks**

Read the operation manual completely—it could save a great deal of unnecessary expense. Read the engine manual supplied.

Check the general condition of the equipment—has it been damaged during delivery? Any damage should be immediately reported to the carrier and a claim registered.

Check engine oil and fuel levels.

Immediately upon taking delivery of your new equipment and before putting it into service:

Recommend lubricants are detailed in the *Maintenance* section.

## **Application**

- Read safety instructions at the beginning of manual.
- Use correct blade for cutting conditions.
- Clean the saw, removing dirt and dust, particularly the engine cooling air inlet, carburetor and air cleaner.
- Check the air filter for dirt and dust. If air filter is dirty, replace air filter with a new one as required.
- Check carburetor for external dirt and dust. Clean with dry compressed air.
- Check fastening nuts and bolts for tightness.
- Set unit up in an open area. Avoid close proximity to structures or other equipment.
- Failure to do so may cause inadvertent injury to operator or other persons in the area.

## Blade Placement

**Blade Guard:** Pivot the blade guard front cover all the way back. The guard tension spring will keep the front cover in position.

**Blade Hex Nut:** Unscrew the blade shaft nut (right side loosens clockwise and tightens counter clockwise while the left side loosens counter-clockwise and tightens clockwise. Do not overtighten the nut when finalizing the assembly.

**Outside Blade Flange (Collar):** Ensure that the outside blade flange is placed flush against the diamond blade. The inside surface of the flange must be free of debris and permit a tight closure on the surface of the blade core.

**Diamond Blade:** Ensure that the proper diamond blade has been selected for the job. Pay close attention to the directional arrows on the blade. The blade's operating directional arrows must point in a "down – cutting" direction to perform correctly. When placing the blade onto the blade shaft, ensure the arbor hole of the blade matches the diameter of the shaft. Inner Flange (Collar) – This flange is fixed upon the blade shaft. The inside surface of the flange must be free of debris and permit a tight closure on the surface of the blade.

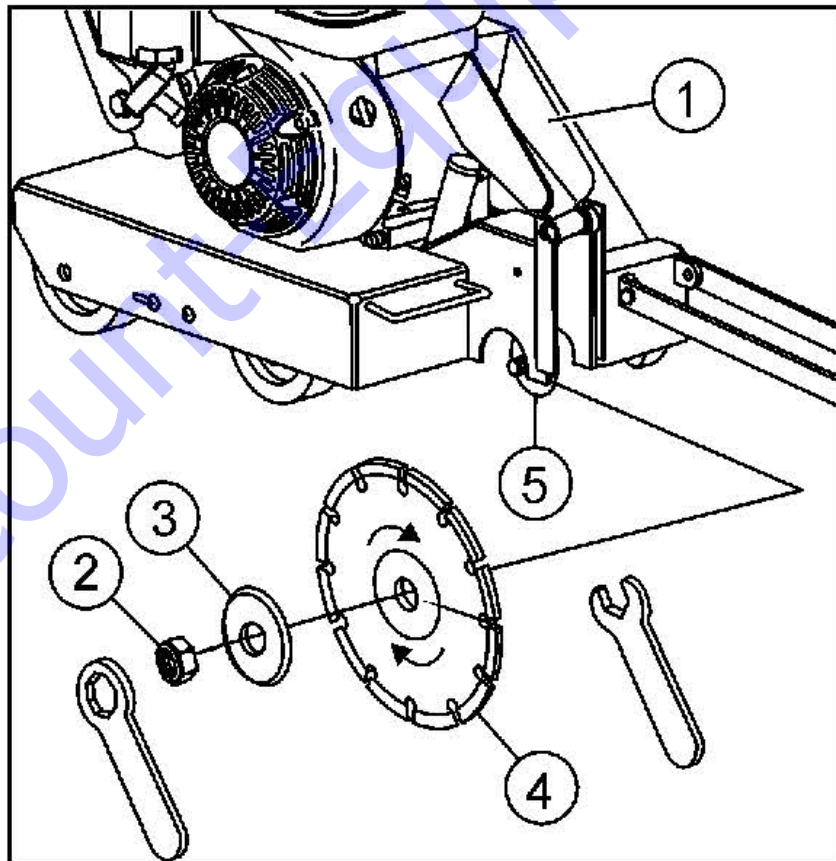

## Operation

1. Ensure the engine Shutdown switch and the engines ON/OFF switch on the engine are both in the OFF position to avoid accidental starting.
2. Place the fuel valve lever to the “ON “Position.
3. Place the engine Shutdown switch and the engine ON/OFF switch on the engine to the “ON Position”.
4. Place the Choke Lever in the “CLOSED” position.
5. Rotate the throttle lever halfway between Fast and Slow for starting. All sawing is done at full throttle. The engine governor speed is factory set to ensure optimum blade operating speeds.
6. Grasp the starter grip and slowly pull it out. The resistant becomes the hardest at a certain position, corresponding to the compression point. Pull the starter grip briskly and smoothly for starting.
7. If the engine has started, slowly return the choke lever to the “OPEN” position. If the engine has not started repeat steps 1 through 5.
8. Before the saw is placed into operation, run the engine for several minutes. Check for fuel leaks, and noises that would associate with a loose guard and/or covers.
9. Rotate the throttle lever toward full throttle.
10. To begin sawing, lower the rotating blade by turning the wheel clockwise and allowing it to cut to the desired depth.
11. When blade has reached full cutting depth, slowly walk behind the saw at a rate that will allow the engine to operate without losing optimum RPM.
12. When the end of the cut has been reached, raise the blade out of the cut by turning the wheel counter clockwise.
13. If cutting is complete, shut the saw down using the following “Shutdown Procedures” (Section 3.2).

## Controls and Components

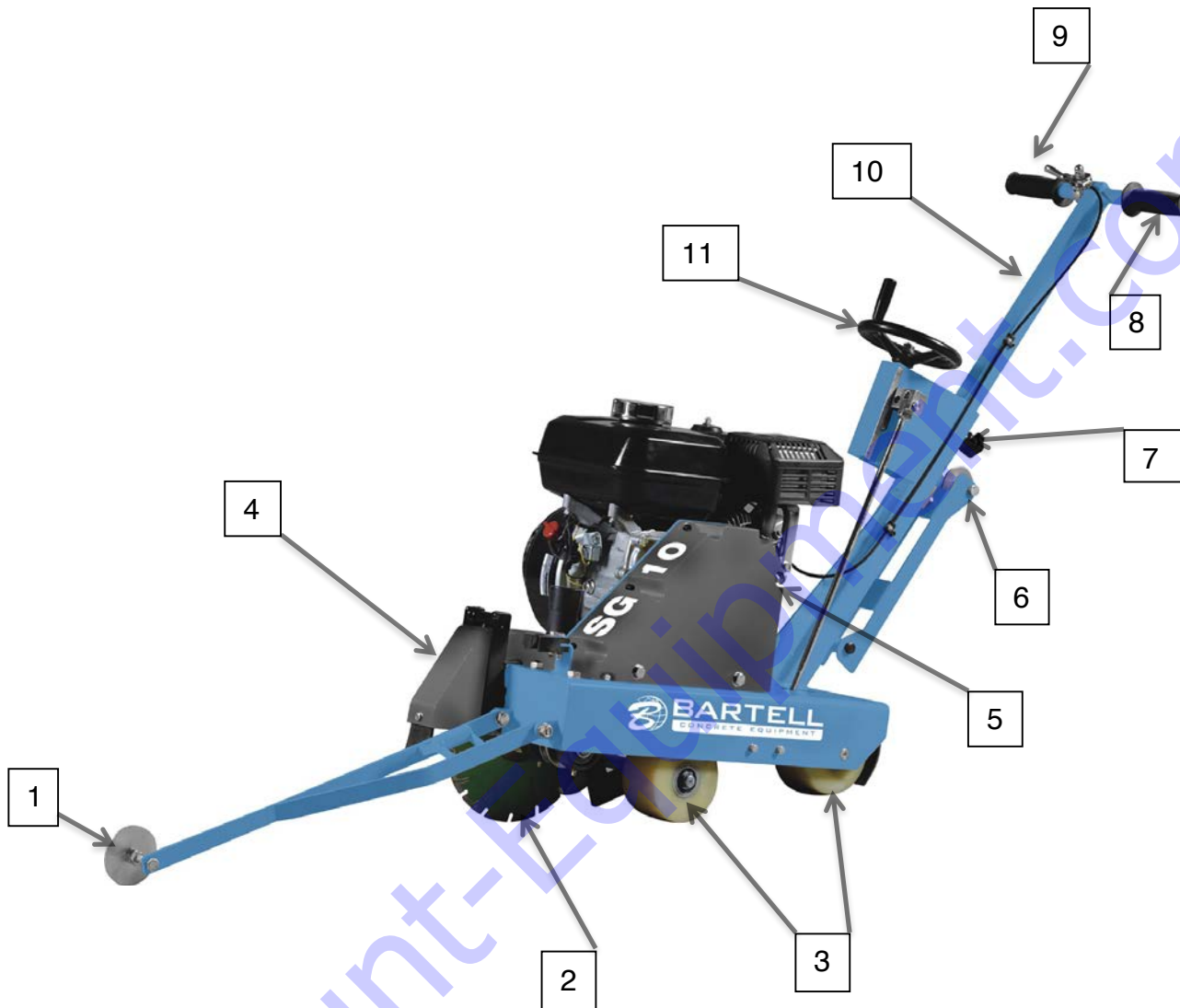

1. Front Guide
2. Diamond Blade
3. Wheels
4. Blade Guard
5. Belt Guard
6. Rear Guide
7. Hand Lock
8. Handle Bar
9. Throttle Lever
10. Adjustable Handle
11. Depth Adjust Wheel



## Maintenance SG10

### **Blade Removal and Replacement**

1. Ensure the Engine Shutdown switch and ON/OFF switch on the engine are turned to the “OFF position”.
2. Place the SG10 Saw on a stable level working surface.
3. Ensure the blade is raised and the raise/lower rod is locked into position.
4. Raise the blade by applying a downward pressure on the handlebars to raise the blade and allow the raise/lower rod to drop into the “raised-position” slot.
5. Lift the blade guard cover to gain access to the diamond blade.
6. Use the provided blade nut and blade shaft locking wrenches to install the diamond blade.
7. While holding the blade shaft with the locking wrench, remove the blade hex nut (clockwise direction) and outer blade flange.
8. Remove the old blade and install a new blade in the same rotational direction as marked on the blade.
9. Reinstall the outer blade flange and hex nut. Tighten the nut firmly (counter-clockwise direction). **Do not overtighten.**

### **Blade Guard Check**

1. Check the following on the “blade guard”: Ensure the capacity of the blade guard matches the diameter of your diamond blade.
2. Check that the guard is bolted firmly upon the saw frame.
3. Check that the spring tensioned front cover of the guard is firmly seated with the rear section of the guard, and there are no gaps. **Never** lift the blade guard while cutting.

## V-Belt Alignment and Tensioning

Remove the bolts that secure the V-belt cover to the saw frame.

Check uniform parallelism of V-belt and pulley (sheaves). Use a straight-edge or machinist's square against both pulleys and adjust both pulleys until equally aligned.

Do not over or under tighten the V-belt. Severe damage can occur to the saw and engine crank shaft if the belt is over-tensioned. A decrease of power to the blade and poor performance will result if the belt is under-tensioned (loose on pulleys).

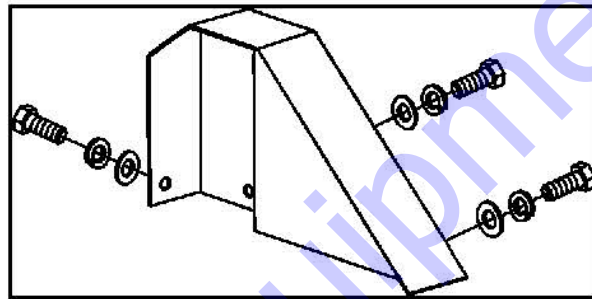

## Troubleshooting SG10

### Blade Troubleshooting

Symptom	Possible Problem	Solution
<b>Blade slows or stops cutting still remains on blade.</b>	Blade too hard for the material being cut?	Consult Dealer for correct blade. Try cutting very soft material (sandstone, silica, brick, cinder block) to "Redress" the blade.
	Engine torque diminished because of loose v-belt?	Tighten and/or replace v-belt
	Insufficient engine power?	Check throttle setting, and engine horsepower.
	Improper direction of rotation?	Check that the blade is properly oriented and rotational arrow points in a "Down- Cutting" direction.
	Blade is slipping on the blade shaft?	Check that the blade & flange pin are properly installed on the blade shaft.
<b>Blade does not cut straight and/or true.</b>	Blade being used on misaligned saw?	Check blade shaft bearings and alignment integrity.
	Blade is excessively hard for the material being cut?	Check specification of the blade with the material being cut. Consult Dealer for information.
	Blade being used at improper RPM?	Ensure a blade surface foot per minute speed (SFPM) is approximately 6,000.
	Blade improperly mounted on arbor shoulders and flanges?	Ensure blade is properly affixed on the blade shaft.
	Excessive force applied to blade while cutting?	Do not force the blade in the cut. Apply a slow and steady pace when sawing.
<b>Blade discoloring, crackling and/or wearing excessively.</b>	Blades too hard for the material being cut?	Consult Dealer for correct blade. Try cutting very soft material (sandstone, silica, brick, cinder block) to "Redress" the blade.
	Blade improperly mounted on arbor shoulders and flanges?	Ensure blade is properly affixed on the blade shaft.

**Blade Troubleshooting continued:**

<p><b>Blade discoloring, crackling and/or wearing excessively.</b></p>	<p>Blade not receiving enough cooling air?</p>	<p>Ensure proper flow &amp; volume of water is provided for wet cutting blades. Ensure sufficient cooling air is circulated about a dry cutting blade.</p>
	<p>Arbor hole out of round?</p>	<p>Ensure blade is properly affixed on the blade shaft.</p>
	<p>Incorrect blade chosen for material being cut?</p>	<p>Check specification of the blade with the material being cut. Consult Dealer or for information.</p>
	<p>Excessive force applied to blade while cutting?</p>	<p>DO NOT force the blade in the cut. Apply a slow and steady pace when sawing.</p>

Discount-Equipment.com

## Engine Troubleshooting

Symptom	Possible Problem	Solution
<b>Difficult to start, “fuel is available, but no SPARK at spark plug”.</b>	Spark plug bridging?	Check gap, insulation or replace spark plug.
	Carbon deposit on spark plug?	Clean or replace spark plug.
	Short circuit due to deficient spark plug insulation?	Check spark plug insulation, replace if worn.
	Improper spark plug gap?	Set to proper gap.
<b>Difficult to start, “fuel is available, and SPARK is present at the spark plug”.</b>	ON/OFF switch is shorted?	Check switch wiring, replace switch.
	Ignition coil defective?	Replace ignition coil.
	Improper spark gap, points dirty?	Set correct spark gap and clean points.
	Condenser insulation worn or short circuiting?	Replace condenser.
	Spark plug wire broken or short circuiting?	Replace defective spark plug wiring.
<b>Difficult to start, “fuel is available, spark is present, and compression is normal”.</b>	ON/OFF switch is shorted?	Check switch wiring, replace switch.
	Ignition coil defective?	Replace ignition coil.
	Improper spark gap, points dirty?	Set correct spark gap and clean points.
	Choke Open?	Close Choke.
<b>Difficult to start, “fuel is available, spark is present, and compression is low”.</b>	Suction/exhaust valve stuck or protruded?	Re-seat valves.
	Piston ring and/or cylinder worn?	Replace piston rings and or piston.
	Cylinder head and/or spark plug not tightened properly?	Torque cylinder head bolts and spark plug.

### Engine Troubleshooting Continued:

<b>Difficult to start, “fuel is available, spark is present, and compression is low”.</b>	Head gasket and/or spark plug gasket damaged?	Replace head and spark plug gaskets.
<b>No fuel present at the carburetor.</b>	Fuel not available in fuel tank?	Fill with correct type of fuel.
	Fuel filter clogged?	Replace fuel filter.
	Fuel tank cap breather hole clogged?	Clean or replace fuel tank cap.
	Air in fuel line?	Bleed fuel line.
<b>“Weak in power” compression is proper and does not misfire.</b>	Air cleaner not clean?	Clean or replace air cleaner.
	Improper level in carburetor?	Check float adjustment.
		Rebuild carburetor.
Defective spark plug?	Clean or replace spark plug.	
<b>Engine overheats.</b>	Wrong fuel type?	Flush fuel system, and replace with correct type of fuel.
	Spark plug heat value improper?	Replace with correct type of spark plug.
<b>Rotational speed fluctuates.</b>	Governor adjusted correctly?	Adjust governor.
	Governor spring defective or missing?	Replace governor spring.
	Fuel flow restricted?	Check entire fuel system for leaks or clogs.
<b>Recoil starter malfunction.</b>	Recoil mechanism clogged with dust and dirt?	Clean recoil assembly with soap and Recoil starter water.
	Spiral spring loose?	Replace spiral spring.

**Technical Data SG10**

Model	SG10K	SG10S
Engine Type	Kholer CH270	Subaru EX21
Power kw (hp)	5.2 (7.0)	5.2 (7.0)
Weight kg (lb)	51 (112)	49 (108)
Cutting depth mm (in)	82.6 (3.25)	
Blade Size mm (in)	254 (10)	
Standard Arbor Size mm (in)	15.88 (0.625)	
Depth Adjustment	Handle Rotation	

Working Size mm:

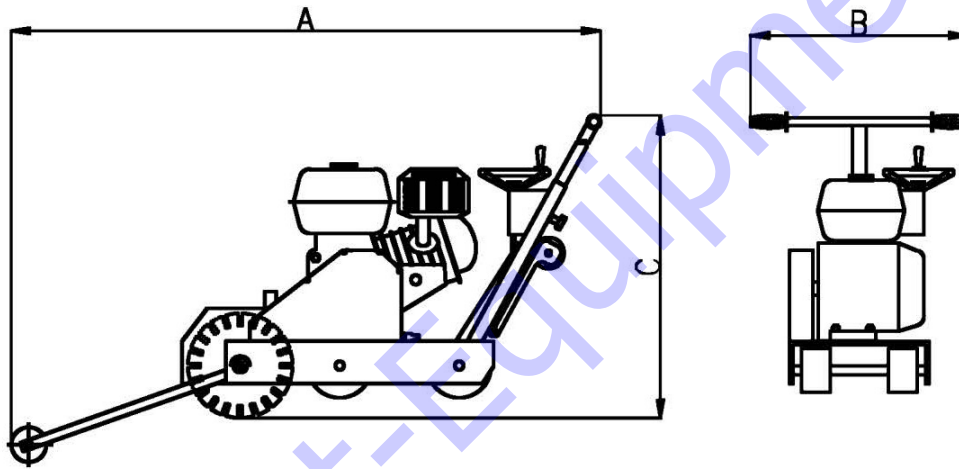

SG10 A=1665 B=340 C=920

Sound Specification (According to 2000/14/EC)	
Measured Power Level	88 dB (A)
Guaranteed Sound Power Level	110 dB (A)

This Page Intentionally Left Blank

Discount-Equipment.com