

BARTELL

CONCRETE EQUIPMENT

INSTRUCTION MANUAL & PARTS BOOK

Vibratory Screed



**Discount
Equipment**

www.Discount-Equipment.com

Doc. # OI-M09201
Current Rev. 07
Revised: 11/2013
Orig. Rel.: 06/2014

PARTS FINDER

**Search Website
by Part Number**



**Search Manual
Library For Parts
Manual & Lookup Part
Numbers – Purchase
or Request Quote**

Search Manuals

Enter your information to search for parts manuals and lookup part numbers.

* Brand:

* Model:

* Serial:

* Part Number:

SEARCH

**Can't Find Part or
Manual? Request Help
by Manufacturer,
Model & Description**

Parts Order Form

Please fill in the following information:

Manufacturer:

Model:

Description:

Quantity:

Part Number:

Part Name:

Part Description:

Part Drawing:

Part Location:

Part Status:

Part Condition:

Part Material:

Part Color:

Part Weight:

Part Dimensions:

Part Notes:

Submit

Discount-Equipment.com is your online resource for quality parts & equipment.





Florida: **561-964-4949** Outside Florida TOLL FREE: **877-690-3101**

Need parts?

Click on this link: <http://www.discount-equipment.com/category/5443-parts/> and choose one of the options to help get the right parts and equipment you are looking for. Please have the machine model and serial number available in order to help us get you the correct parts. If you don't find the part on the website or on one of the online manuals, please fill out the request form and one of our experienced staff members will get back to you with a quote for the right part that your machine needs.

We sell worldwide for the brands: Genie, Terex, JLG, MultiQuip, Mikasa, Essick, Whiteman, Mayco, Toro Stone, Diamond Products, Generac Magnum, Airman, Haulotte, Barreto, Power Blanket, Nifty Lift, Atlas Copco, Chicago Pneumatic, Allmand, Miller Curber, Skyjack, Lull, Skytrak, Tsurumi, Husquvarna Target, Stow, Wacker, Sakai, Mi-T-M, Sullair, Basic, Dynapac, MBW, Weber, Bartell, Bennar Newman, Haulotte, Ditch Runner, Menegotti, Morrison, Contec, Buddy, Crown, Edco, Wyco, Bomag, Laymor, EZ Trench, Bil-Jax, F.S. Curtis, Gehl Pavers, Heli, Honda, ICS/PowerGrit, IHI, Partner, Imer, Clipper, MMD, Koshin, Rice, CH&E, General Equipment, Amida, Coleman, NAC, Gradall, Square Shooter, Kent, Stanley, Tamco, Toku, Hatz, Kohler, Robin, Wisconsin, Northrock, Oztec, Toker TK, Rol-Air, APT, Wylie, Ingersoll Rand / Doosan, Innovatech, Con X, Ammann, Mecalac, Makinex, Smith Surface Prep, Small Line, Wanco, Yanmar

VIBRATORY SCREED INSTRUCTION MANUAL & PARTS BOOK

SAFETY PRECAUTIONS	
	<p> DANGER</p> <p>EXPLOSION HAZARD Never operate the machine in an explosive atmosphere, near combustible materials or where ventilation does not clear exhaust fumes.</p>
	<p>WARNING</p> <p>BURN HAZARD Never come into contact with the engine or muffler when engine is operating or shortly after it is turned off. Serious burns may occur.</p>
	<p> CAUTION</p> <p>MOVING PARTS Before starting the machine ensure that all guards and safety devices are in place and functioning properly.</p>
	<p> ATTENTION</p> <p>READ OWNERS MANUAL Read and understand operator's manual before using this machine. Failure to follow operating instructions could result in serious injury or death.</p>

VIBRATORY SCREED INSTRUCTION MANUAL & PARTS BOOK

TABLE OF CONTENTS

VIBRATORY SCREED WARRANTY	4
MAINTENANCE RECORD	5
SPECIFICATIONS	6
OPERATING TIPS & REMINDERS	7
SCREED ASSEMBLY	8
SCREED ADJUSTMENT	13
VIBRATIONS ADJUSTMENT	15
HAND WINCH ASSEMBLY INSTALLATION	16
END ADAPTOR ASSEMBLY INSTALLATION	18
ASSEMBLY DRAWINGS AND PARTS LIST	20
ENGINE ASSEMBLY	21
5' BASE SECTION	22
10' BASE SECTION	23
2.5' SUBSECTION	25
5' SUBSECTION	26
10' SUBSECTION	27
HYDRAULIC SELF-PROPELLED ASSEMBLY (RH)	28
HYDRAULIC SELF-PROPELLED ASSEMBLY (LH)	29
SELF PROPELLED ASSEMBLY	30
MOTOR ASSEMBLY	31
SELF-PROPELLED / HYDRAULIC ASSEMBLY	32
SELF-PROPELLED / HAND WINCH CABLE ASSEMBLY	33
HYDRAULIC TANK ASSEMBLY	34
SELF-PROPELLED SHAFT ASSEMBLY	35
TURN BUCKLE ASSEMBLY	36
PILLOW BLOCK BEARING ASSEMBLY	37
CAST BEARING ASSEMBLY	38
CONNECTING HARDWARE	39
HAND WINCH ASSEMBLY	40
END ADAPTOR ASSEMBLY	41
COMPANY INFORMATION	43

VIBRATORY SCREED INSTRUCTION MANUAL & PARTS BOOK

SUPER AND STANDARD SCREED WARRANTY

Bartell Morrison Inc. agrees to furnish without charge, F.O.B. our plant, a replacement for any part or portion thereof, comprising the main unit of the MORRISON SCREED, consisting of the drive shaft assembly and the gear case assemblies, save and except drive belts, and power units, and/or bearing or electrical controls which prove upon our examination, to be defective in either material or workmanship within a period of twelve (12) months from date of purchase, provided that notice of such defective part or portion thereof is given to Bartell Morrison Inc. within the twelve month warranty period. No further or other guarantee or warranty expressed or implied in connection with the sale of the MORRISON SCREED is given and our sole liability consists in replacing defective parts or portions thereof. We shall not be responsible for any special, indirect or consequential damages arising in any manner whatsoever. This guarantee is for the sole benefit of the original purchaser as end user. Our responsibility under this guarantee ends in the case the original purchaser transfers ownership of the MORRISON SCREED, makes any changes or adds any parts or devices not of our manufacture to the MORRISON SCREED.

VIBRATORY SCREED INSTRUCTION MANUAL & PARTS BOOK

MAINTENANCE RECORD

PREVENTATIVE MAINTENANCE AND ROUTINE SERVICE PLAN

This MORRISON SCREED has been assembled with care and will provide years of service. Preventative maintenance and routine service are essential to the long life of your Screed. Your dealer is interested in your new machine and has the desire to help you get the most value from it. After reading through this manual thoroughly, you will find that you can do some of the regular maintenance yourself. However, when in need of parts or major service, be sure to see your Bartell Morrison dealer. For your convenience we have provided this space to record relevant data about your MORRISON SCREED. When in need of parts or service be prepared to provide your Screed serial number. Locate the serial number now and record in the space below.

Date Purchased:		Type of Screed:	
Dealer Name:		Model:	
Dealer Phone:		Base Serial Number(s):	

REPLACEMENT PARTS USED				MAINTENANCE LOG	
PART NO.	QUANTITY	COST	DATE	DATE	OPERATION

VIBRATORY SCREED INSTRUCTION MANUAL & PARTS BOOK

MORRISON STANDARD SCREED SPECIFICATIONS

SPECIFICATIONS AND DIMENSIONS:

Height:	13.5"	(342.9mm)
Width:	12.125"	(307.98mm)
Weight: 10' Base Section:	79 lbs.	(35.87kg)
5' Section:	45 lbs.	(20.43kg)
2.5' Section:	23 lbs.	(10.44kg)
10' Section:	78 lbs.	(35.41kg)
Motor w/mount:	53 lbs.	(24.06kg)
Engine:	5.5hp Honda (others available)	
Maximum Recommended Span:	45'	(13.7m)
Average Peak Vibration:	12.830 v.p.m.	
Maximum Compaction Depth:	12"	(304.8mm)

MORRISON SUPER SCREED SPECIFICATIONS

SPECIFICATIONS AND DIMENSIONS:

Height:	19.5"	(495.3mm)
Width:	14.625"	(371.48mm)
Weight: 10' Base Section:	94 lbs.	(42.68kg)
5' Section:	46 lbs.	(20.88kg)
2.5' Section:	23 lbs.	(10.44kg)
10' Section:	91 lbs.	(41.31kg)
Motor w/mount:	70 lbs.	(31.73kg)
Engine:	5.5hp Honda (others available)	
Maximum Recommended Span:	70'	(21.31m)
Average Peak Vibration:	14,000 v.p.m.	
Maximum Compaction Depth:	12"	(304.8mm)

OPERATING TIPS AND REMINDERS

1. Before operating this equipment, read all of the manuals provided.
2. Keep all guards and covers in good repair and installed in the proper places.
3. Always turn off engine before refueling.
4. Keep hands, feet and loose clothing away from the screed shaft, drive belt, and engine clutch.
5. Keep hands, feet and loose clothing away from the cable drums and the drive belt area of the hydraulic self-propelled units.
6. Check the shaft connections each day to make sure that the bolts are secure. Replace any bolts that look worn!
7. Do not sit on the screed as this could cause deflection or possibly damage the unit.
8. The screed is designed to finish off concrete NOT to grade it! Keep excess concrete away from the screed blades during the placing operation. Excessive amounts of concrete could cause deflection or damage to the screed. Concrete should be low enough so that the top of the bolts along the screed blades can be seen.
9. Engine should be shut down whenever forward movement of the screed is stopped. Do not allow the engine to idle for more than 2 minutes as damage to the clutch may occur.

VIBRATORY SCREED INSTRUCTION MANUAL & PARTS BOOK

OPERATOR'S SECTION

In the next few pages you will find the proper procedures for assembly and operation of your screed. Please read and follow these instructions carefully to avoid damage to the screed or possible injury due to improper assembly procedures!

SCREED ASSEMBLY



When shipped, the engine and the motor mount kit are in two separate boxes. Upon opening the boxes, you should find the following: The engine, clutch, clutch guard, engine mounting plate and a bolt bag with the necessary mounting hardware.

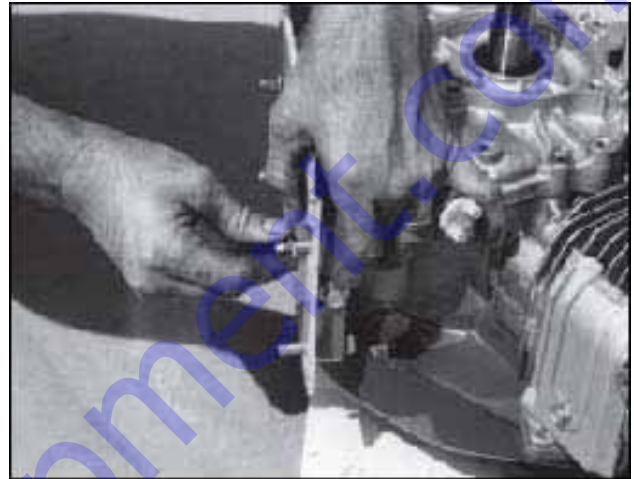

Bolt the engine to the mounting plate. Using the hardware supplied.



Install the clutch on the engine shaft. On a 10 ft base unit, the pulley side is toward the back of the engine (as shown). On a 5 ft base unit, the pulley side is towards the front of the engine.



In the bolt bag you will find a 1/4"x1/4" key. Align the slot in the clutch with the slot in the engine and insert the key.

SCREED ASSEMBLY



Secure the clutch onto the engine shaft using the proper bolt, flat washer, and lock washer plate provided. See page 2 of 'Assembly Drawings and Parts List'.



Attach the clutch guard to the engine mounting plate, hand tighten nut.



The main section of the screed is the base unit, with the drive belt and engine mounting bracket attached. Slip the drive belt over the clutch and bolt to the top of the base unit.



Install the bolts, washers, and nuts through the engine mounting plate, and connect the plate to the screed. Do Not Tighten Bolts!

SCREED ASSEMBLY



The belt can now be adjusted. The proper tension is about 1/2" of give on the belt when moderate pressure is applied to the center of the belt. Tighten the engine mounting bolts.



Position the clutch guard over the clutch, and tighten the bolt.



Begin assembly of the screed sections by removing the packing material. Remove the hardware bag attached to each section carefully so that you do not lose any of the hardware inside. NOTE: Sections connect to the left-hand end of the base unit, as you face the screed, starting with the longest section and proceeding to the shortest one. The only exception will be that the right-hand self-propelled unit will bolt to the right-hand end of the base section.

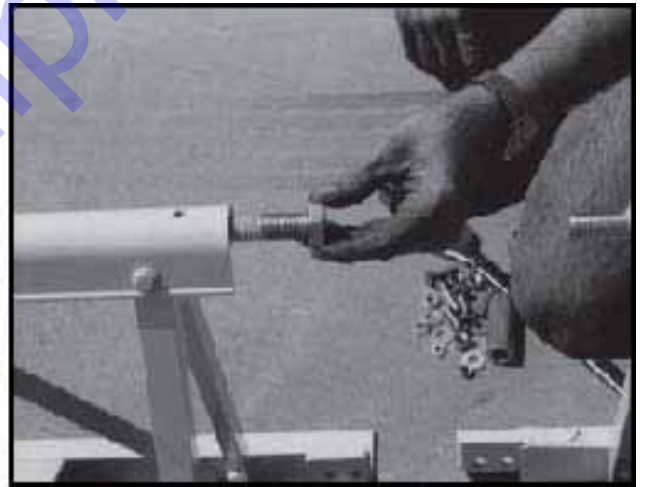

Locate the 3/4" jam nut and install it onto the right -hand threaded rod at the top of the screed.

SCREED ASSEMBLY

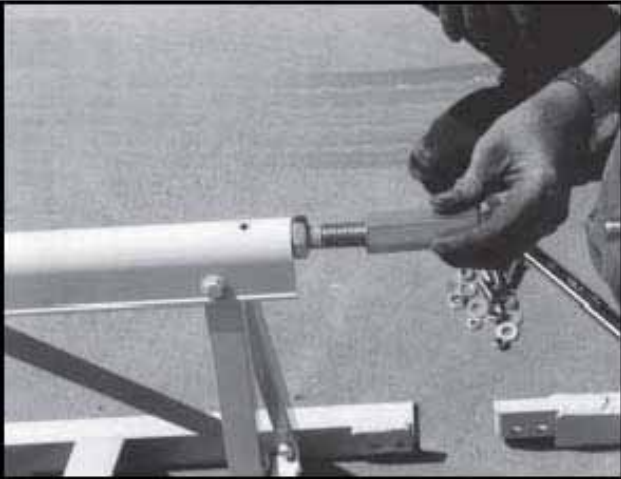

The turnbuckle is the long octagon shaped piece with a left-hand thread at one end and a right-hand thread at the opposite end. Place it on the same right-hand threaded rod as the jam nut, turning it only about one to one and one half turns.



Position the section so that the turnbuckle is aligned with the threaded rod at the top of the section you are joining it with. As the turn-buckle is turned it will begin to draw the two sections together.



Bring the connecting holes into alignment with each other. A drift pin may be helpful here to align the holes for the bolts.

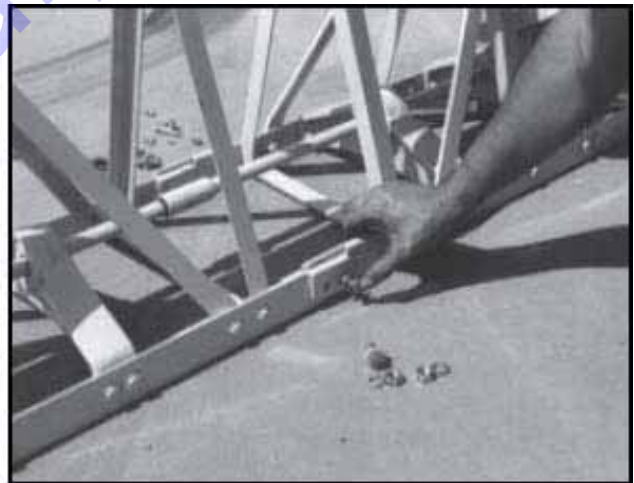

Install the bolts with a flat washer from the outside of the blades, and a lock washer on the inside. After installing all four of the bolts, tighten them securely.

SCREED ASSEMBLY

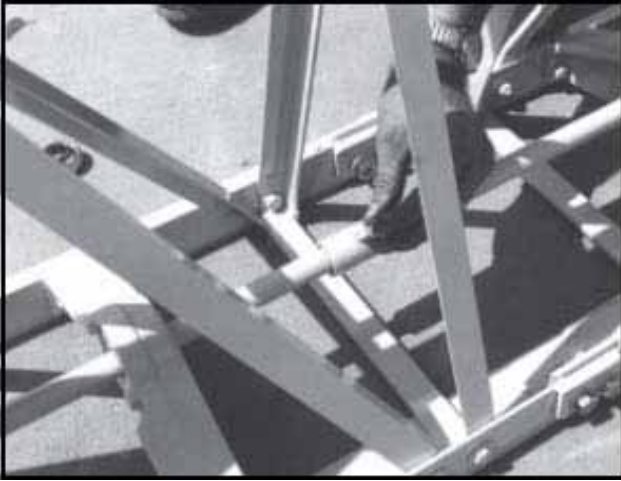

Align the shafts and connect them using the hardware supplied.



When installing the self-propelled units, check the alignment of the shaft pulley to the pump pulley. If alignment is necessary, loosen the set screw, using the allen wrench provided, and slide the shaft pulley so that it aligns with the pump pulley.



Make sure that the key in the pulley is under the pulley completely before tightening the set screw.



Check the pulley and belt alignment, and make sure that the key is fully inserted under the pulley, tighten set screw.

ADJUSTING SCREED

The adjustment of the screed for flatness will take several minutes. This should be done prior to each use or for use in a crown or valley operation. Be certain that the screed is adjusted properly and the jam nuts are tight *before* concrete placement begins.



Once the length of screed you need is assembled, place a 2"x4" under each end, or set the screed onto the forms you are using.



Fasten a string to the form and draw it as tightly as possible about 1" off the back of the screed. Make sure that the string is not in contact with the screed, or any other object that could cause a variance.



Use a guide placed beneath the blades to determine where adjustment is needed. Begin adjusting the turnbuckles along the top of the screed to align the screed with the string. Adjust the screed from the outside sections and work toward the center. Tighten jam nuts. NOTE: This will probably take several times to get a perfectly flat machine.

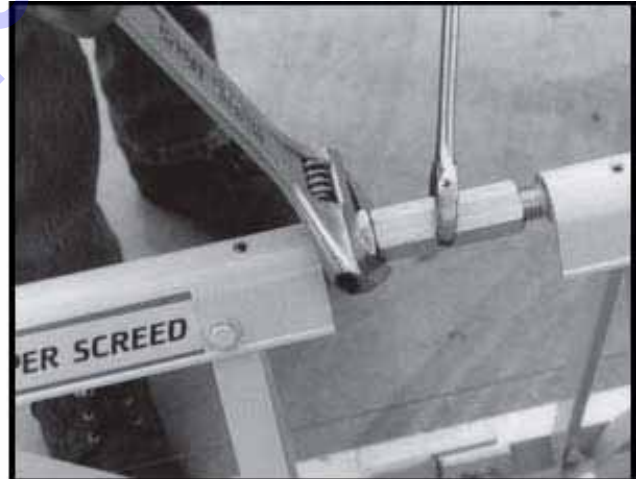

After adjustments are made tighten jam nut securely so that vibration from the screed does not loosen it allowing movement during placing of concrete.

ADJUSTING SCREED

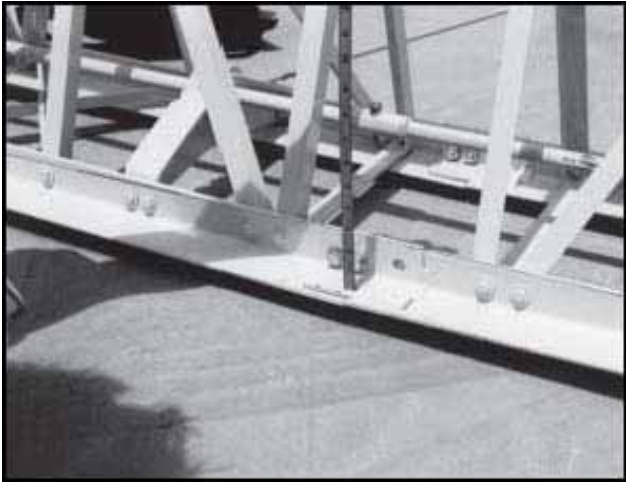

The screed can place concrete in an invert situation of up to 1/4" per foot. Simply locate a turnbuckle where you need the invert and use a ruler and string line to give you the proper measurement. CAUTION: Remember to tighten the jam nut.

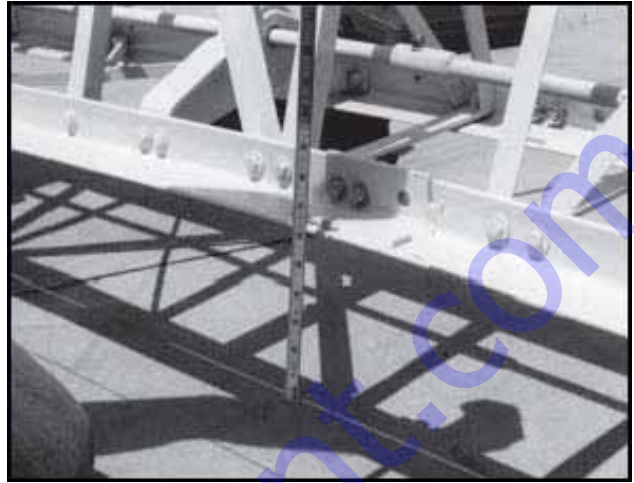

The screed can be used to place concrete in a crowned situation of up to 1/4" per foot, such as street paving. Simply follow the same procedure as in the previous illustration. CAUTION: Remember to tighten the jam nut securely after making adjustments.



To operate the self-propelled units, rotate the drum clutch to a horizontal position to disengage it from the drum. Pull the cable out and attach the hook to a stake or other secure object, in line with the cable drum. Return clutch to the original position.



The speed of travel can be adjusted by turning the needle valve located near the hydraulic tank. Clockwise rotation will increase travel speed, and counter-clockwise rotation will decrease travel speed.

ADJUSTING VIBRATIONS

The vibration frequency of the screed is set at the factory at 12,000 vpm's. Should it become necessary to adjust the vibration, use the instructions below only after consulting your dealer or the factory.



If the screed is not finishing properly, pulling or tearing the concrete, check the engine speeds. The correct RPM setting is 3,450 to 3,600. If the engine RPM's are correct, the screed shaft can be adjusted, within reasonable limits, to increase vibration force.

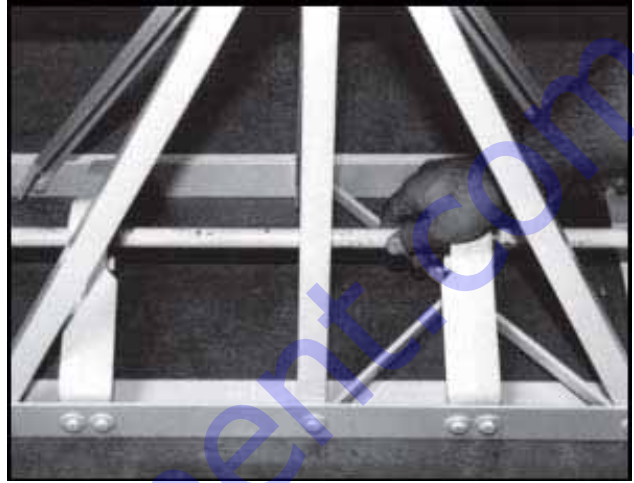

Rotate the screed shaft at the point between the bearing housings where adjustment is needed. You will notice a slight bend in the shaft. Turn the shaft so that the bend is down or away from you.

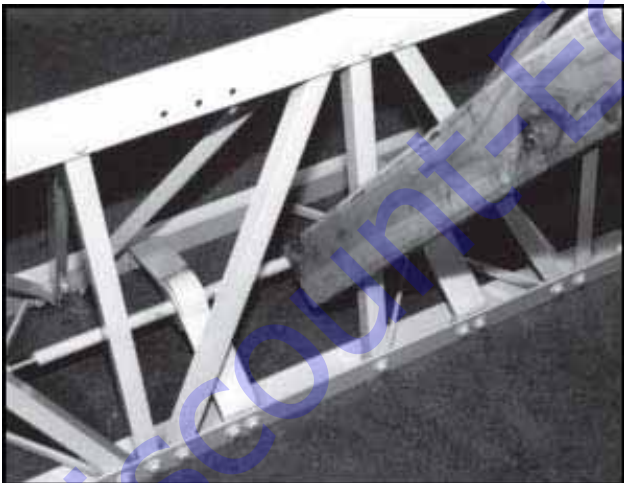

Place a 2x4 against the bend and strike the end with a 6lb. to 8lb. hammer firmly. **NOTE:** The shaft should never be bent over 1/8" or damage to the screed may result. Use extreme caution when bending. Check the shaft before operating the screed.

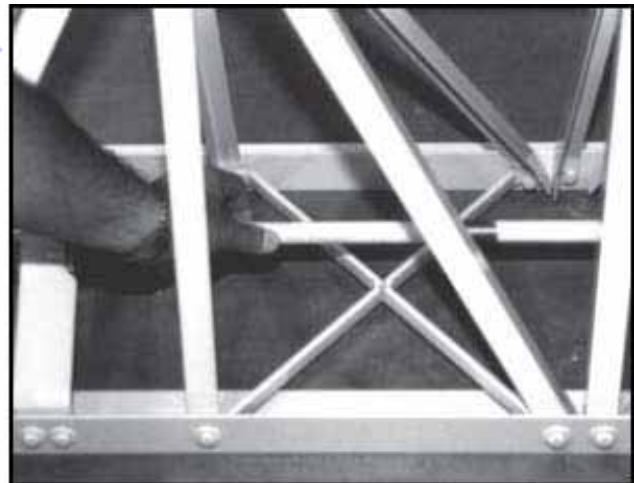

If the screed shaft bent too much you can lessen the bend. Rotate the bend in the shaft towards you and use a 2x4 as described in #3.

INSTALLING HAND WINCH ASSEMBLY

The following instructions will provide complete information for installing the hand winch assembly. Should you need further assistance, contact your dealer or the call factory direct.



Begin installation by removing the last two bolts from the front and rear at one end of the camber top from the section of screed that you will be using.



Place the winch, crank lever out, onto the camber top. Replace the bolts with the longer ones supplied.



On the front blade of the screed, remove the bolts from the angle brace and the cast bearing housing and install the cable pulley bracket, as shown.

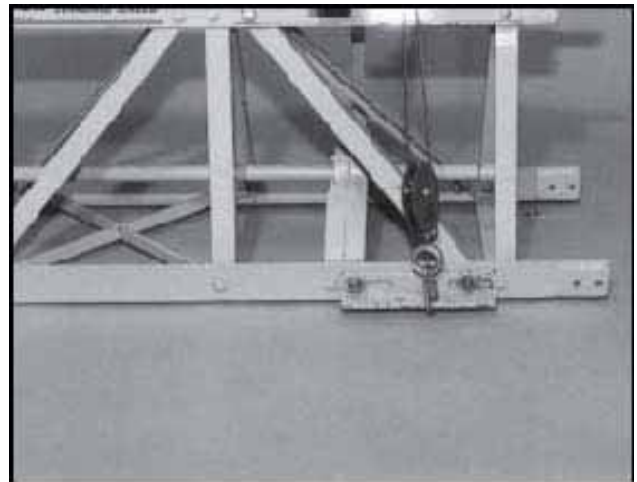

Connect the block pulley bracket to the front blade of the screed. Replace the bolts with the longer ones supplied.

INSTALLING HAND WINCH ASSEMBLY

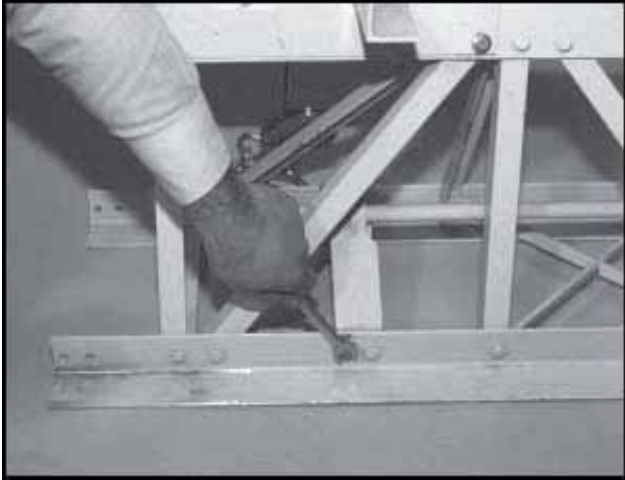

On the rear blade of the screed, remove the bolt from the cast bearing housing nearest the end of the screed.



In the package there is a long brace and a short one. These two bolt together at the twisted end of the long one.

NOTE: Standard Screed dose not require this step.

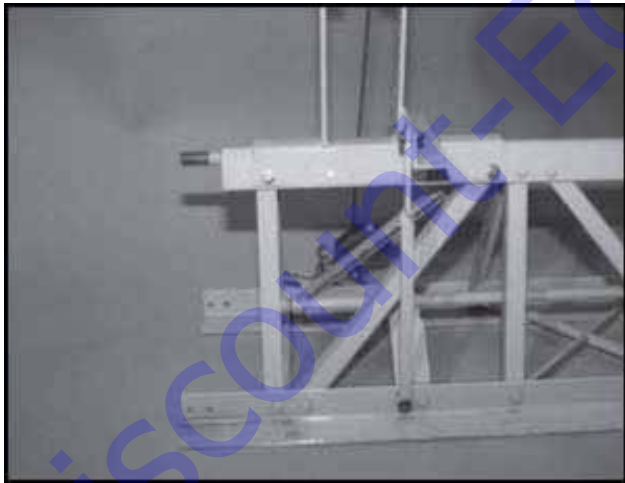

Bolt the brace to the rear of the screed blade and the angle bracket using hardware provided.

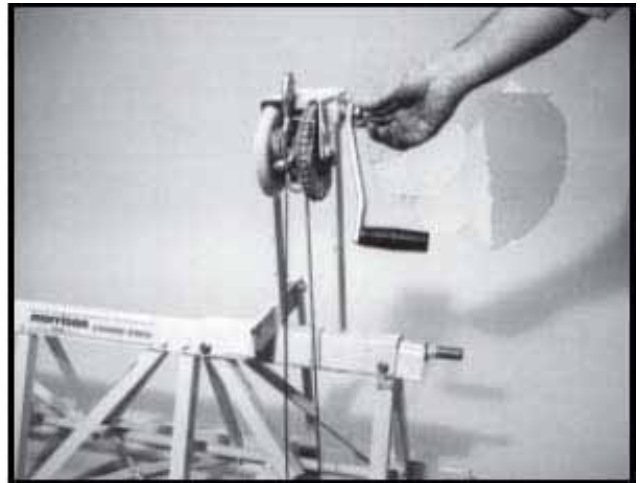

Place the crank handle onto the rod and tighten securely using the locking nut provided. The installation is now complete!

INSTALLING END ADAPTOR ASSEMBLY

The end adaptor installation should take only a few moments using the instructions on the next two pages.

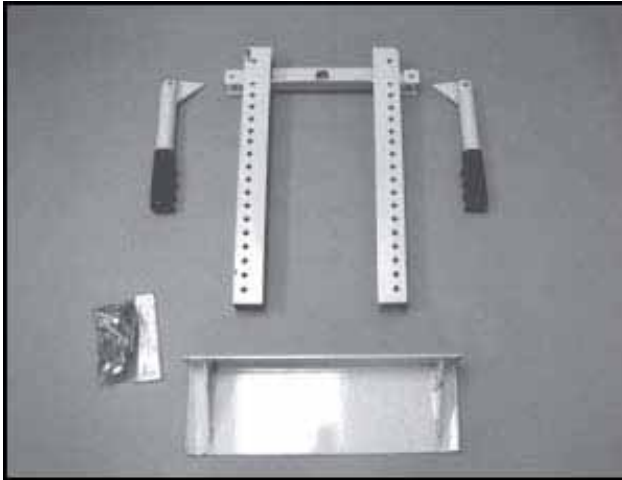

When your end adaptor arrives remove the parts from the box and make sure that you have everything you will need.



Begin installation of the end adaptor assembly by placing the proper jam nut onto the threaded rod at the end of the screed. The threaded rod will be left-hand or right-hand threads, depending on which end of the screed you are working. Both types of nuts are provided in the kit.



Slip the upright into position on the threaded rod and the upright angles on the inside of the screed blades.

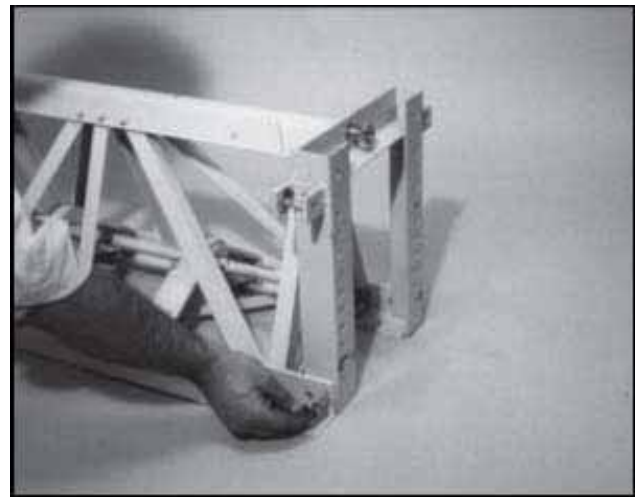

Bolt the upright angles into position using the holes nearest the end of the screed blades.

INSTALLING END ADAPTOR ASSEMBLY

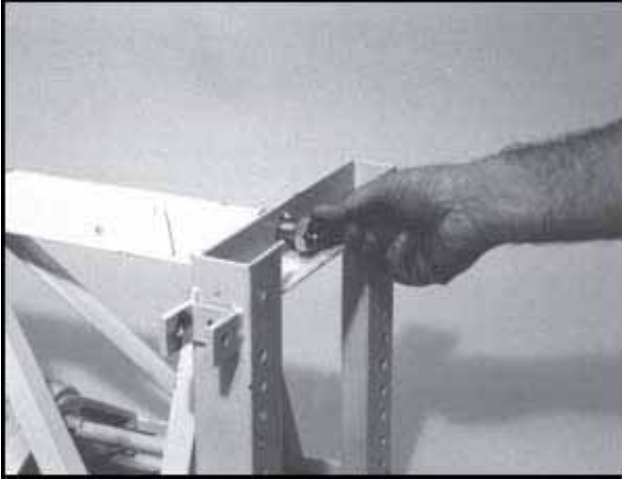

Place a second jam nut on the outer side of the upright. Check to be certain that the upright is vertical before tightening the jam nuts.



Install the rubber grips onto the end adaptor handles, make certain that the grip section is turned properly.



Position the handle into the brackets and bolt securely.

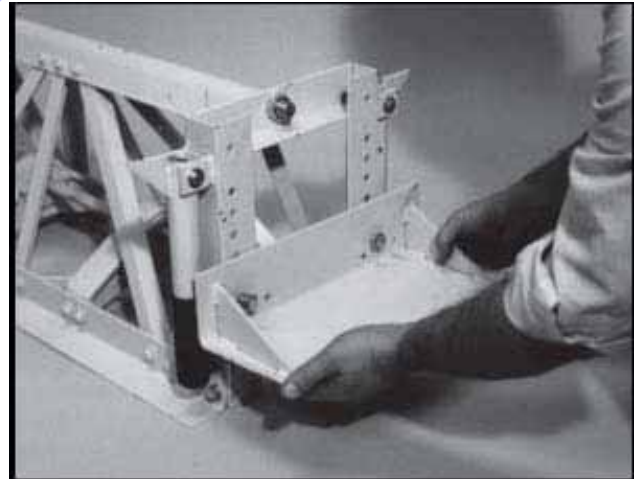

The last step in the end adaptor installation is to position the skid plate at the height that is needed and bolt into position.

ASSEMBLY DRAWINGS AND PARTS LIST



VIBRATORY SCREED INSTRUCTION MANUAL & PARTS BOOK



Model: Screed/Super/Standard
 Title: Engine Assy.

Page: 2

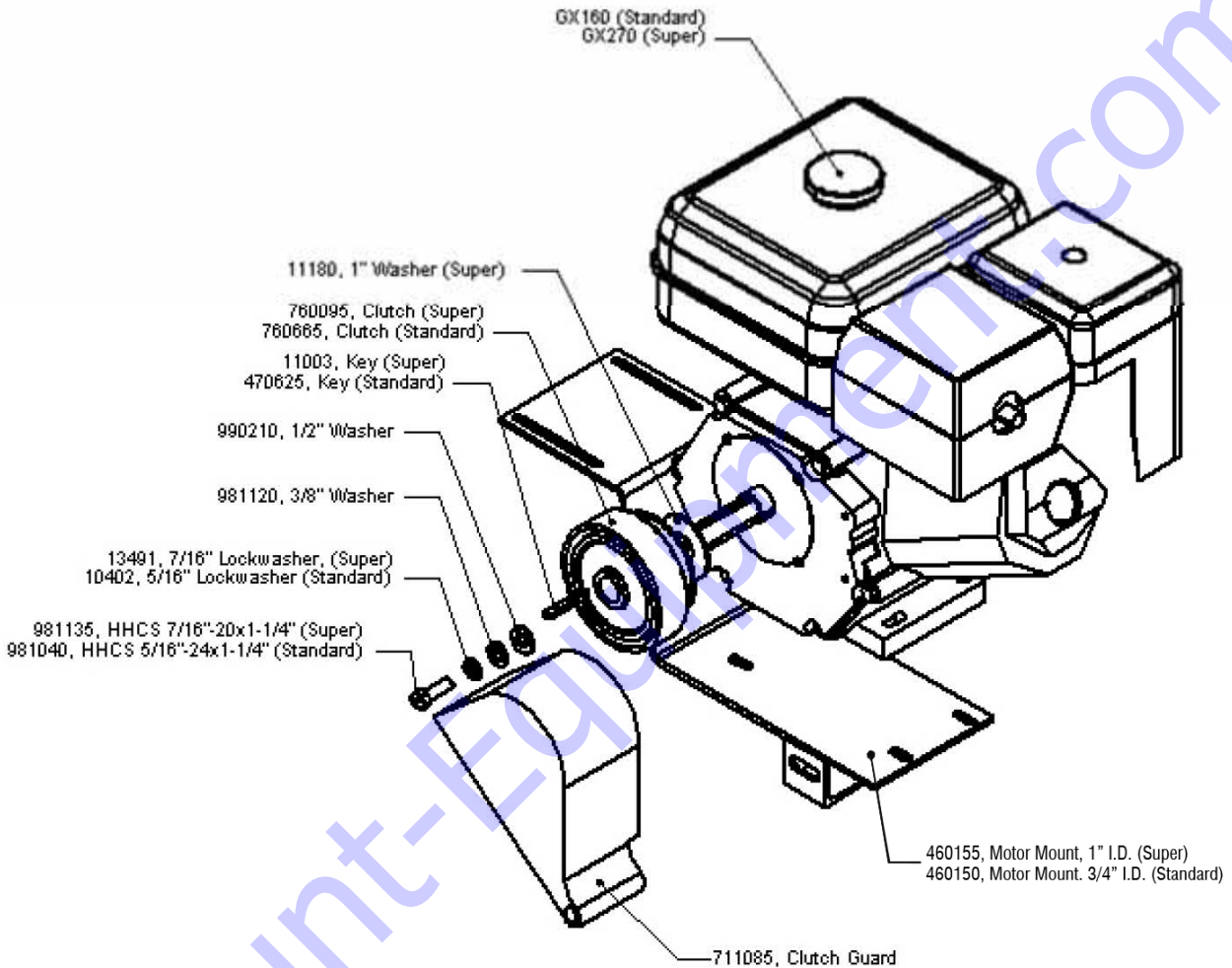

Note: Clutch orientation is shown for the engine assembly on a 10 ft base unit. Clutch orientation on a 5 ft base unit is reversed.

©Amide Industries, Inc. 1997

940130, Motor Fasteners, Std. & Sup.
 940140, Clutch Fasteners, Std. & Sup.

Created: 8-20-97
 By: WW

Revised: a) 11-21-97 d)
 b) 2-4-98 e)
 c) 11-06-13 f)

Document: Screed-P02

VIBRATORY SCREED INSTRUCTION MANUAL & PARTS BOOK



Model: Screed/Super/Standard
 Title: 5' Base Section

Page: 3

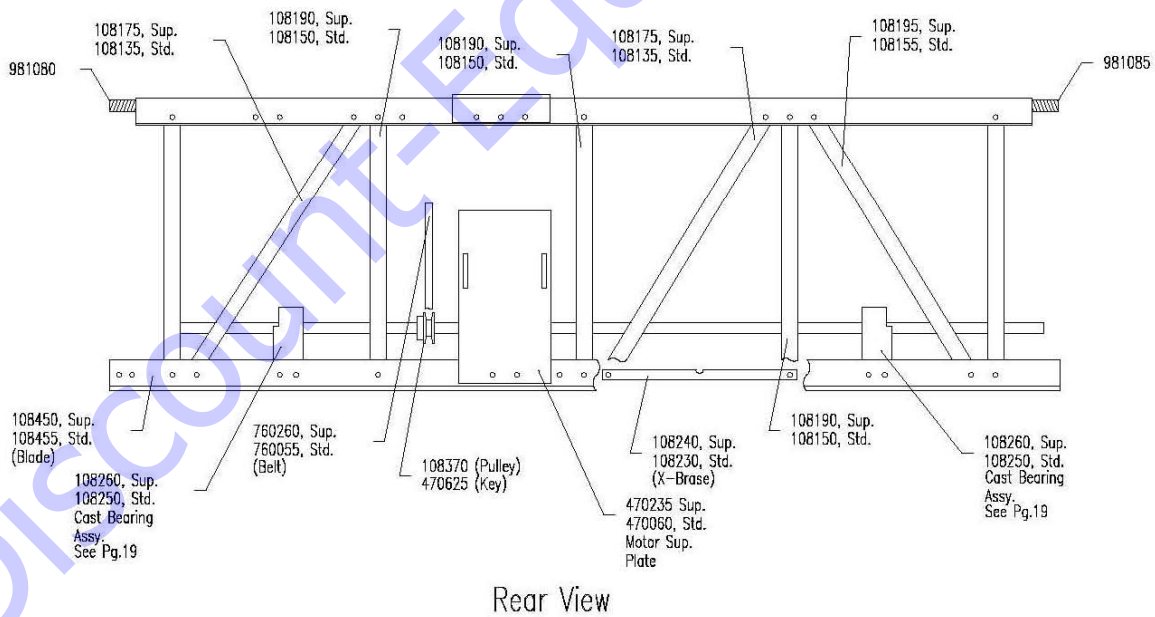
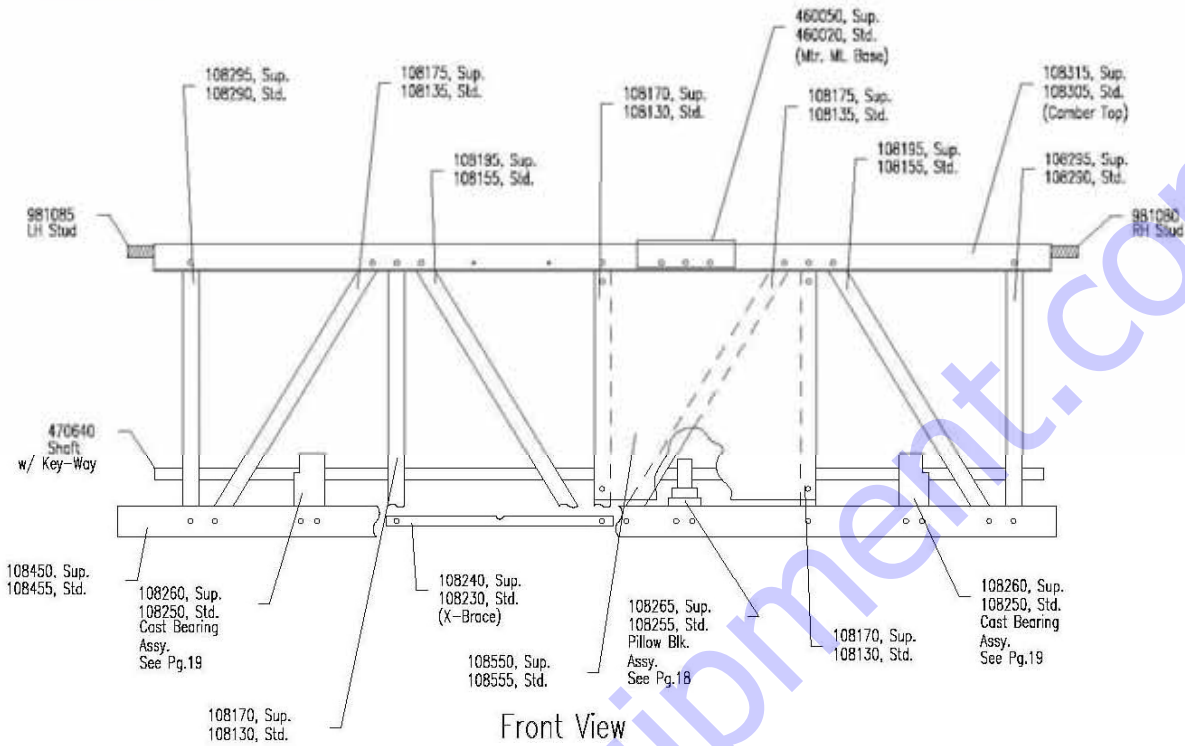

©Amica Industries, Inc. 1997

Created: 8-7-97

By: WW

Revised: a) 11-21-97
 b) 6-3-13
 c)

d)
 e)
 f)

Document: Screed-P03

VIBRATORY SCREED INSTRUCTION MANUAL & PARTS BOOK

	Model:	Screed/Super/Standard	Page:	4
	Title:	10' Base Section		

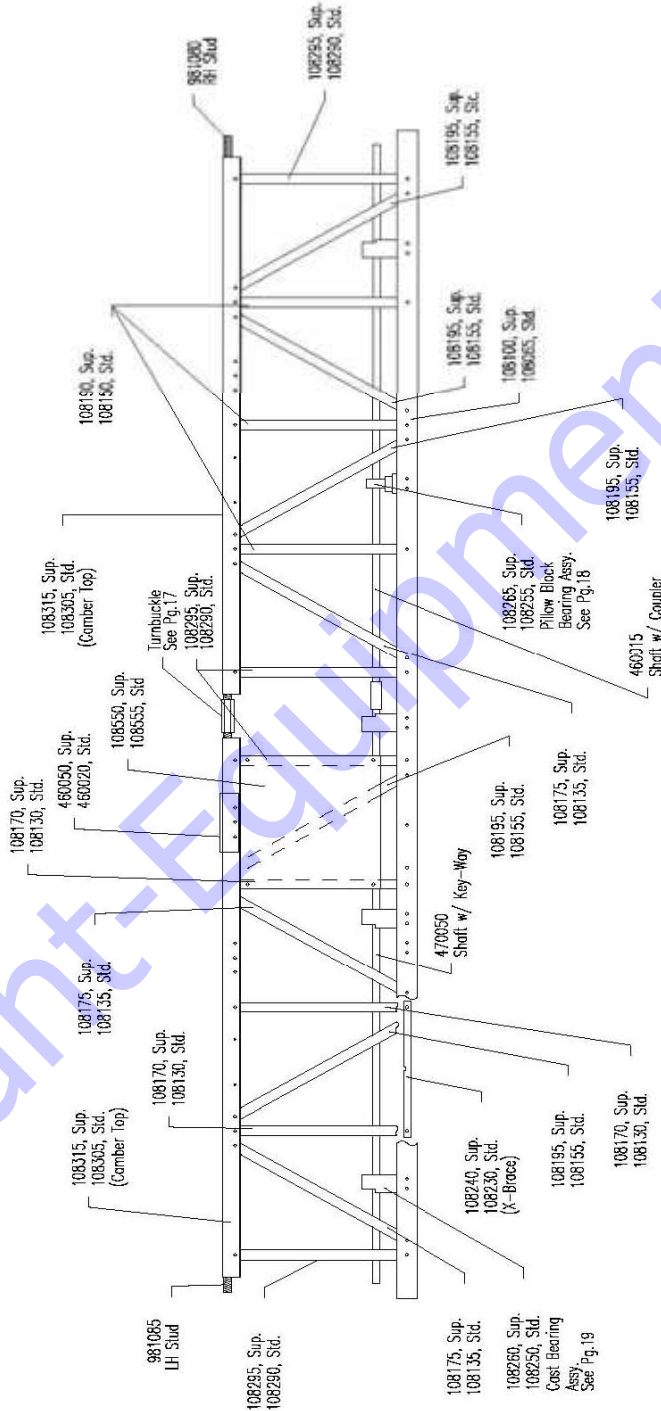

Front View

©Amica Industries, Inc. 1997

Created:	8-7-97	Revised:	a) 11-21-97	d)	Document:	Screed-P04
By:	WW		b) 2-4-98	e)		
			c) 6-3-13	f)		

VIBRATORY SCREED INSTRUCTION MANUAL & PARTS BOOK

	Model:	Screeed/Super/Standard	Page:	5
	Title:	10' Base Section		

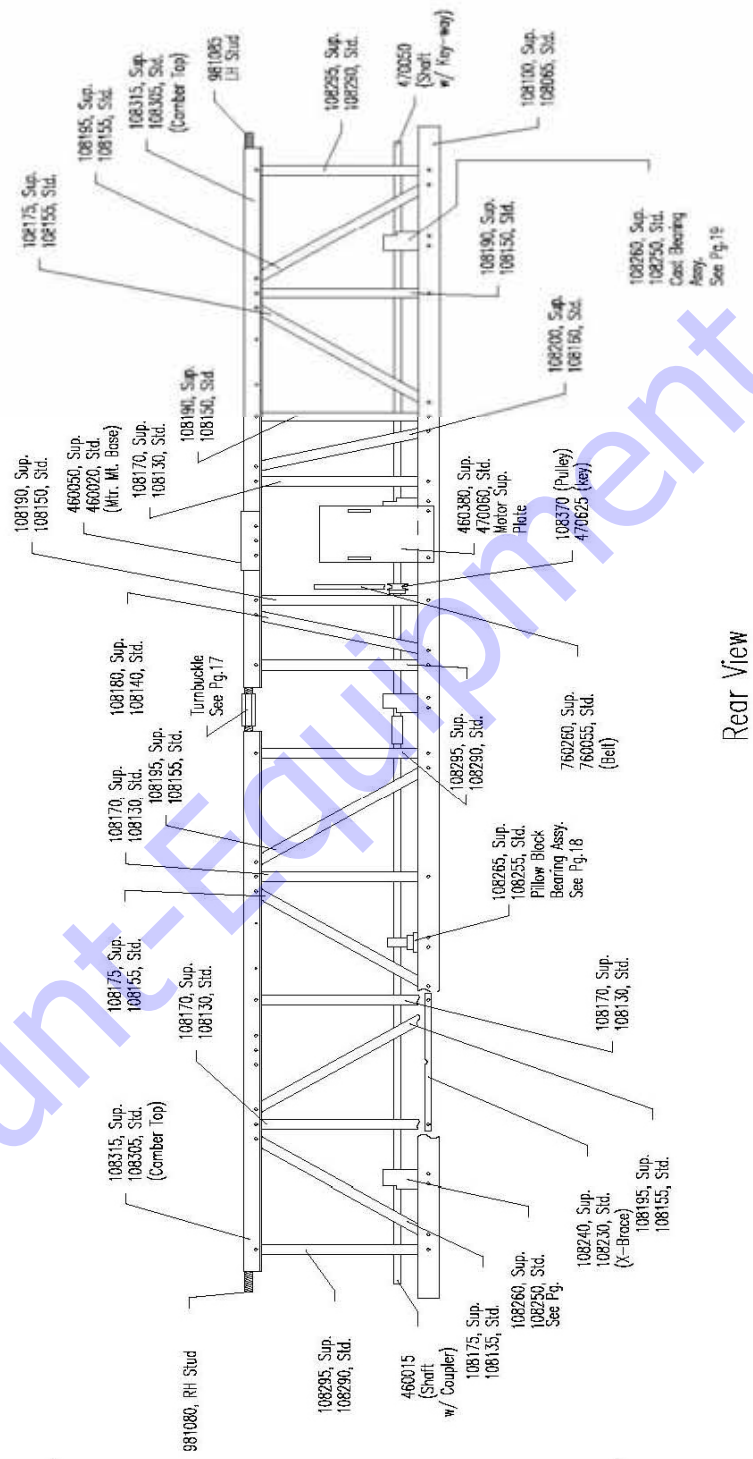

Rear View

©Armid Industries, Inc. 1997

Created:	8-7-97	Revised:	a) 11-21-97 b) 2-4-98 c) 6-3-13	d) e) f)	Document:	Screeed-P05
By:	WW					

VIBRATORY SCREED INSTRUCTION MANUAL & PARTS BOOK



Model: Screed/Super/Standard
 Title: 2.5' Subsection

Page: 6

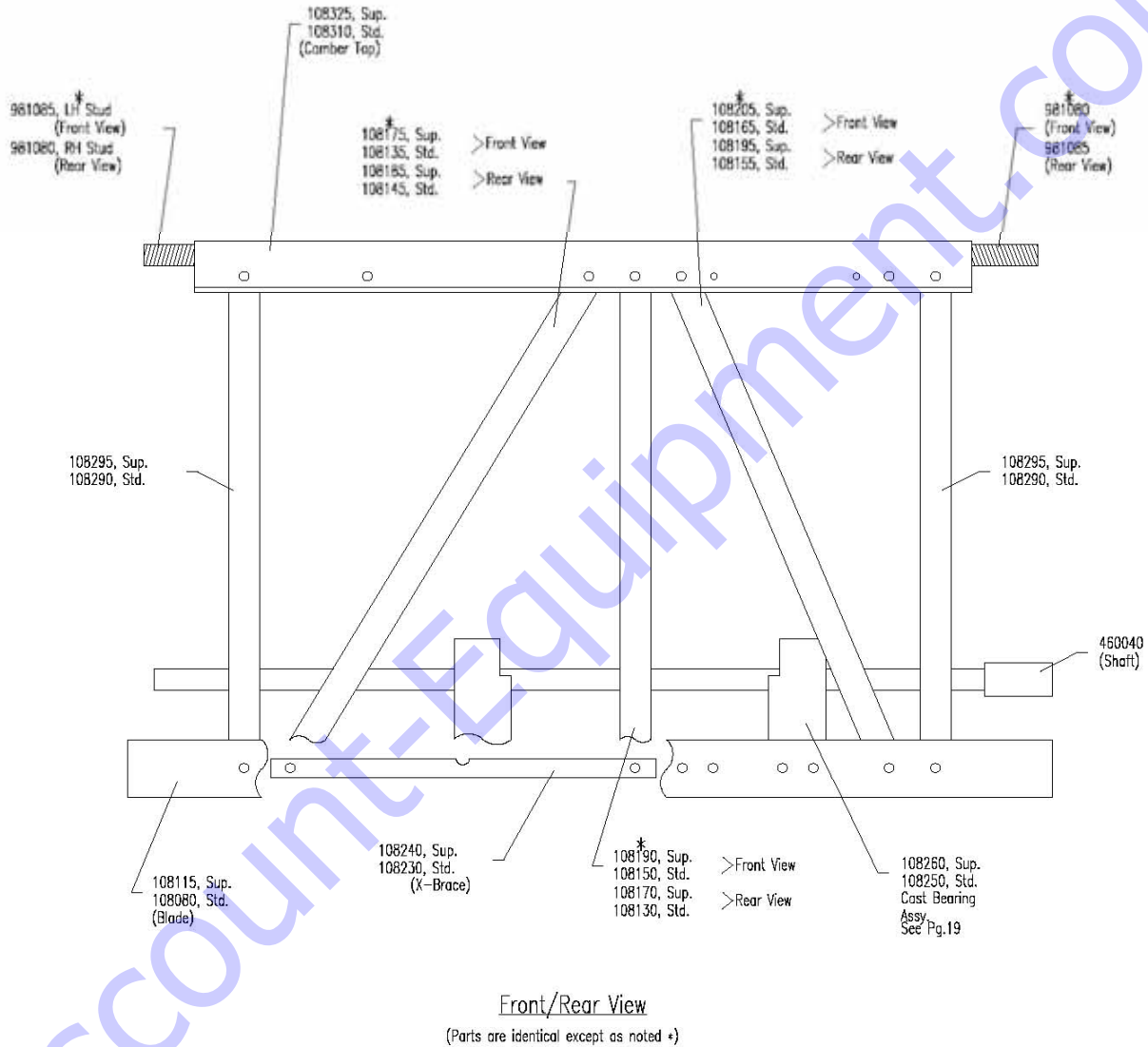

©Amida Industries, Inc. 1997

Created: 8-15-97
 By: WW

Revised: a) 11-21-97 d)
 b) 2-4-97 e)
 c) f)

Document:
 Screed-P06

VIBRATORY SCREED INSTRUCTION MANUAL & PARTS BOOK

	Model: Screed/Super/Standard	Page: 7
	Title: 5' SUBSECTION	

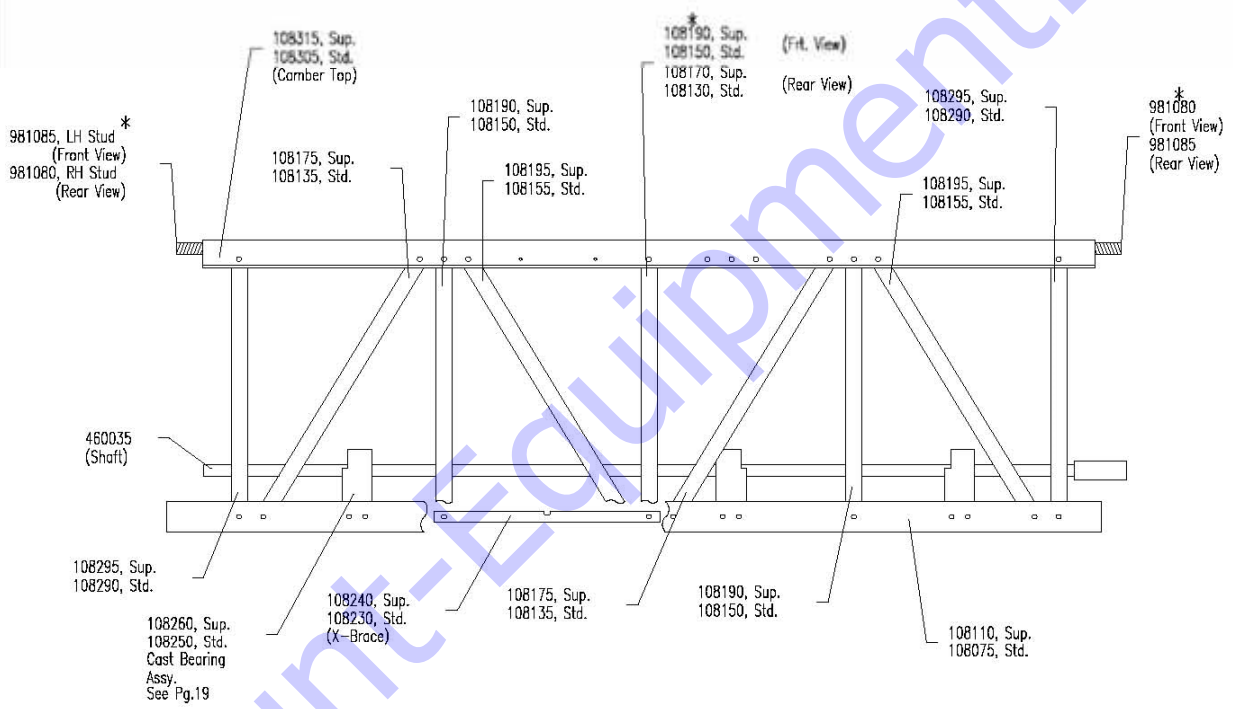

Front/Rear View
 (Parts are identical except as noted *)

Created: 8-11-97	Revised: a) 11-21-97 d)	Document: Screed-P07
By: WW	b) e) c) f)	

VIBRATORY SCREED INSTRUCTION MANUAL & PARTS BOOK

VIBRATORY SCREED INSTRUCTION MANUAL & PARTS BOOK

	Model: Screed/Super/Standard	Page: 8
	Title: 10' SUBSECTION	

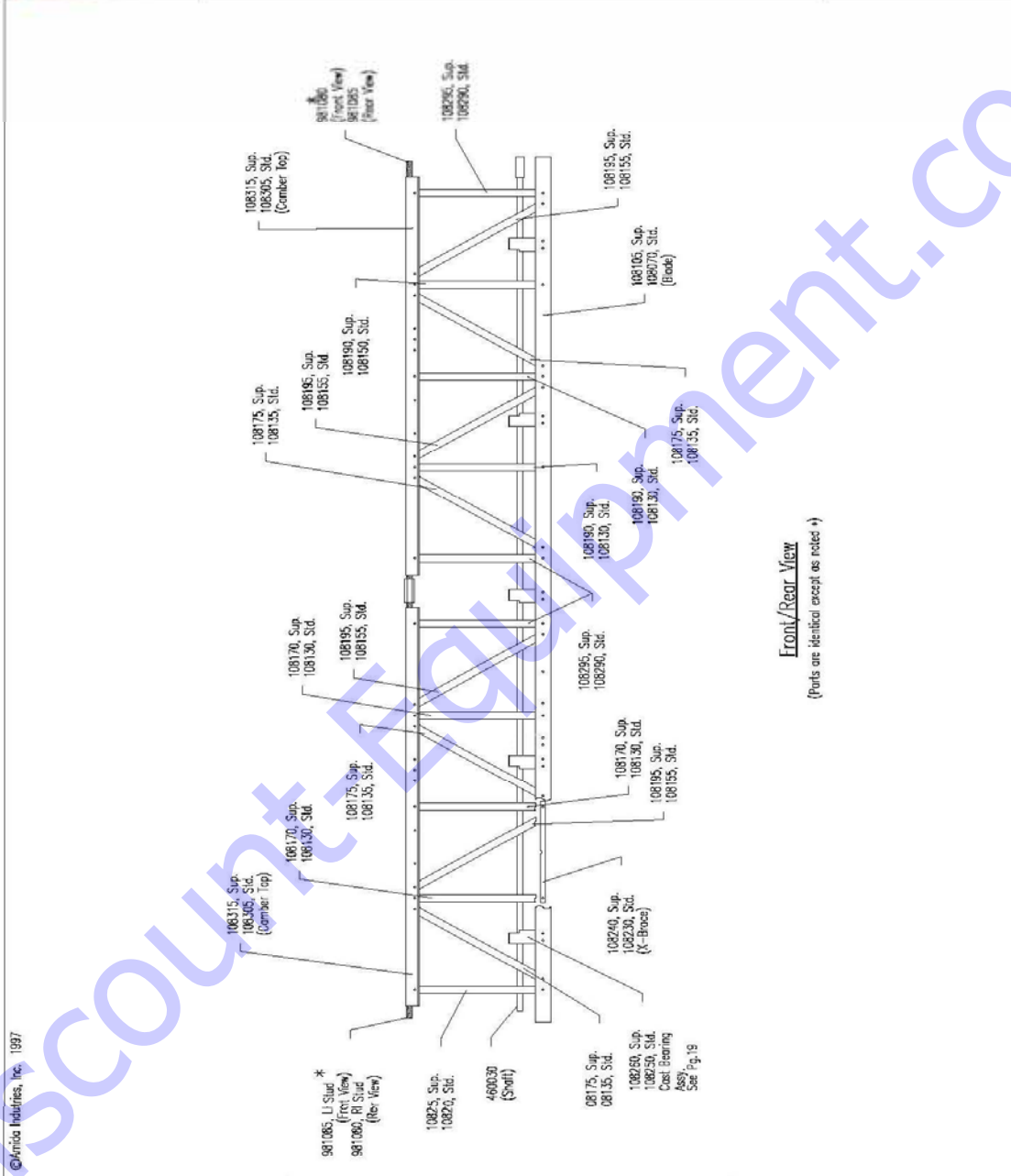

Front/Rear View
 (Parts are identical except as noted →)

Created: 8-11-97	Revised: a) 11-21-97 d) b) 08-27-13 e) c) n	Document: Screed-P08
By: WW		



www.Discount-Equipment.com

Revised: 06/13
 Created: 02/10

Revised: 11/13
 Created: 06/14

VIBRATORY SCREED INSTRUCTION MANUAL & PARTS BOOK

	Model: Screed/Super/Standard	Page: 9
	Title: Hydraulic Self-Propelled Assembly (RH)	

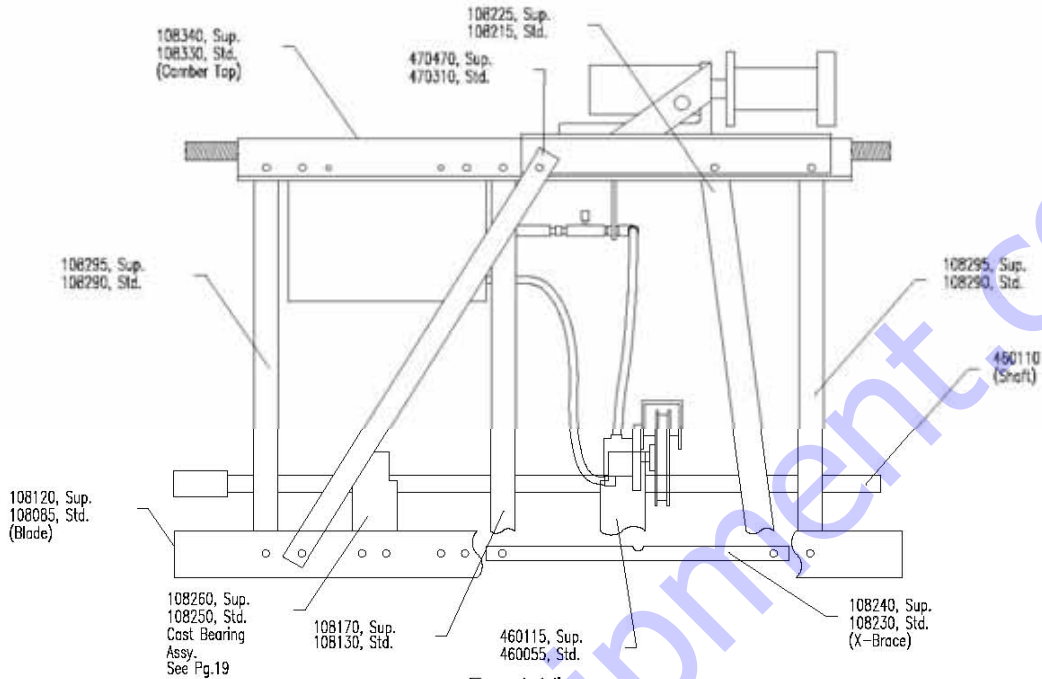

Front View

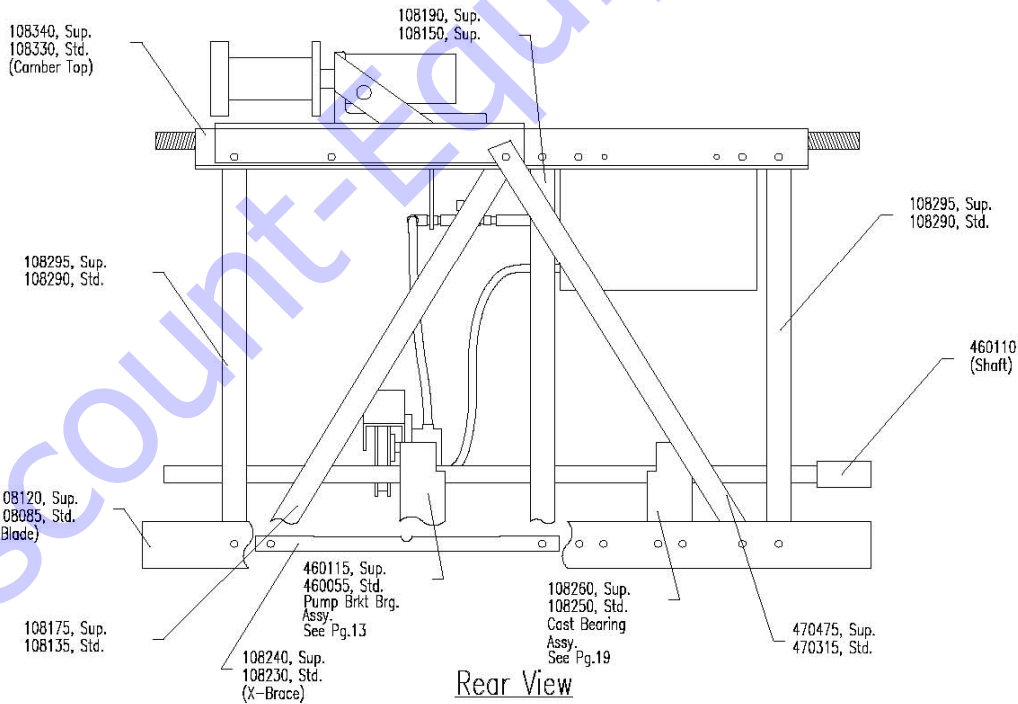

Rear View

©Amida Industries, Inc. 1997

Created: 8-15-97

By: WW

Revised: a) 11-21-97
b) 2-4-98
c)

d)
e)
f)

Document:

Screed-P09

VIBRATORY SCREED INSTRUCTION MANUAL & PARTS BOOK



Model: Screed/Super/Standard
 Title: Hydraulic Self-Propelled Assembly (LH)

Page: 10

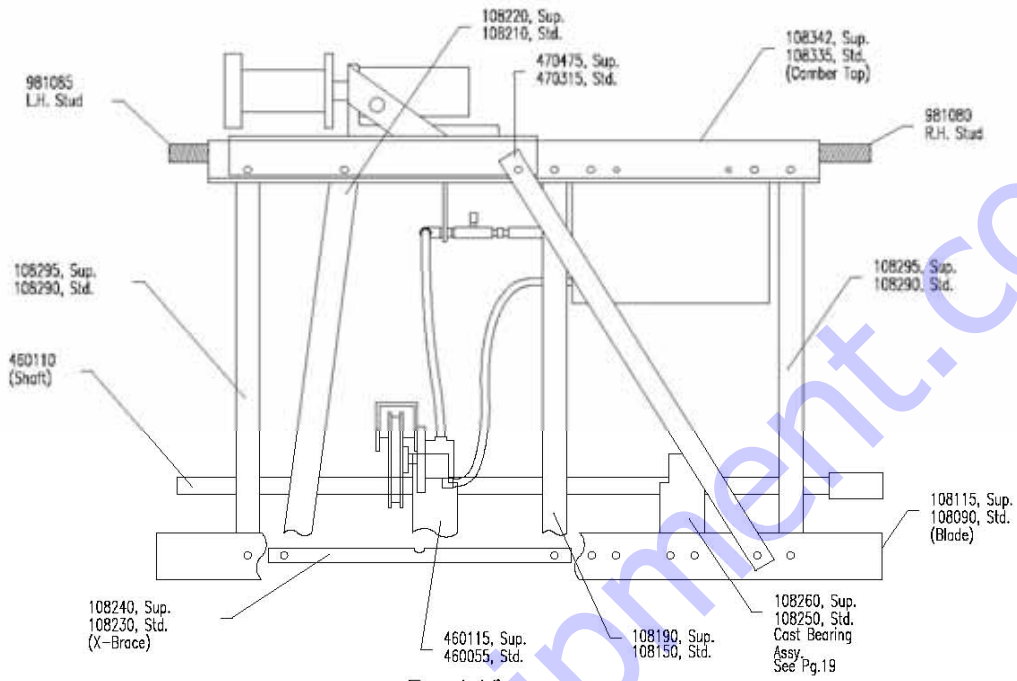

Front View

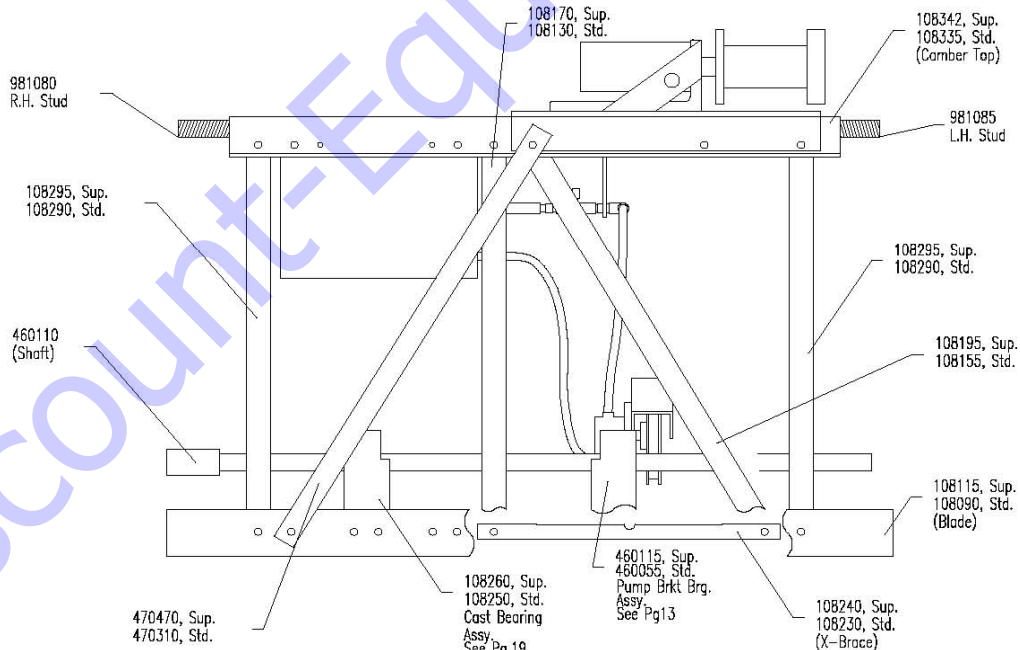

Rear View

©Arnold Industries, Inc. 1997

Created: 8-15-97

By: WW

Revised: a) 11-21-97 d)
 b) 2-4-98 e)
 c) f)

Document: Screed-P10

VIBRATORY SCREED INSTRUCTION MANUAL & PARTS BOOK



Model:	Screed/Super/Standard	Page:	11
Title:	Self-Propelled Assembly		

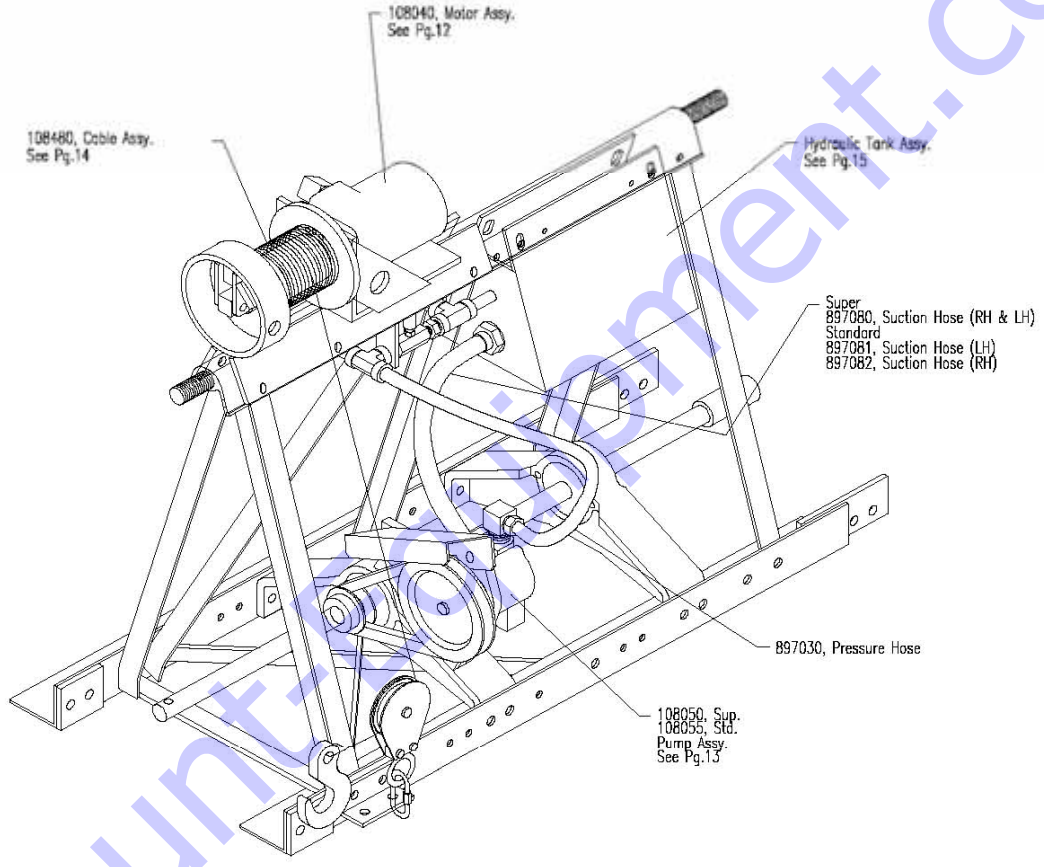

©Armdo Industries, Inc. 1997

Created:	8-15-97
By:	WW

Revised:	a) 11-21-97	d)
	b)	e)
	c)	f)

Document:	Screed-P11
-----------	------------

VIBRATORY SCREED INSTRUCTION MANUAL & PARTS BOOK



Model: Screed/Super/Standard
 Title: Motor Assembly

Page: 12

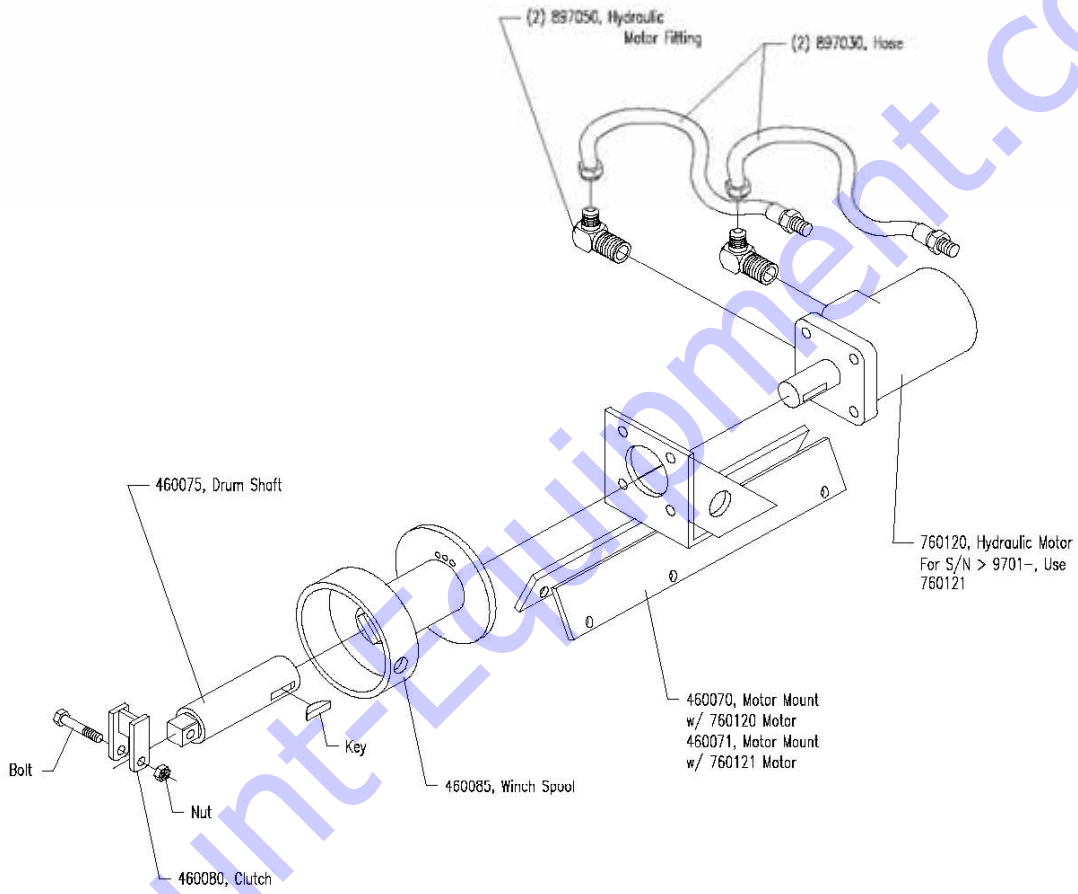

©Amvita Industries, Inc. 1997

Created: 8-15-97
 By: WW

Revised: a) 11-21-97 d)
 b) e)
 c) f)

Document: Screed-P12

VIBRATORY SCREED INSTRUCTION MANUAL & PARTS BOOK



Model: Screed/Super/Standard
 Title: Self-Propelled/Hydraulic Pump Assy.

Page: 13

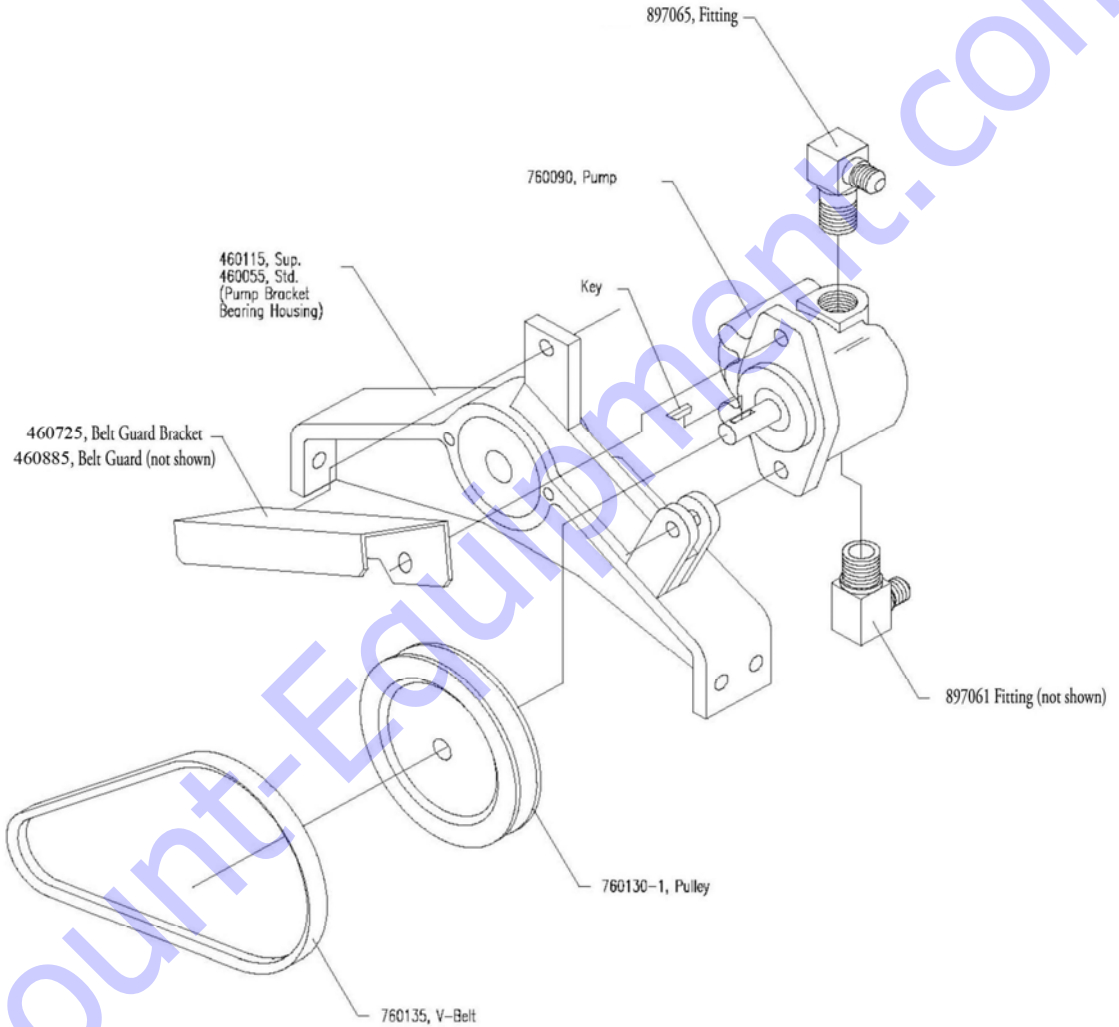

©Amid Industries, Inc. 1997

Created: 8-18-97
 By: WW

Revised: a) d)
 b) e)
 c) f)

Document: Screed-P13

VIBRATORY SCREED INSTRUCTION MANUAL & PARTS BOOK



Model: Screed/Super/Standard
 Title: Self-Propelled/Hand Winch Cable Assy.

Page: 14

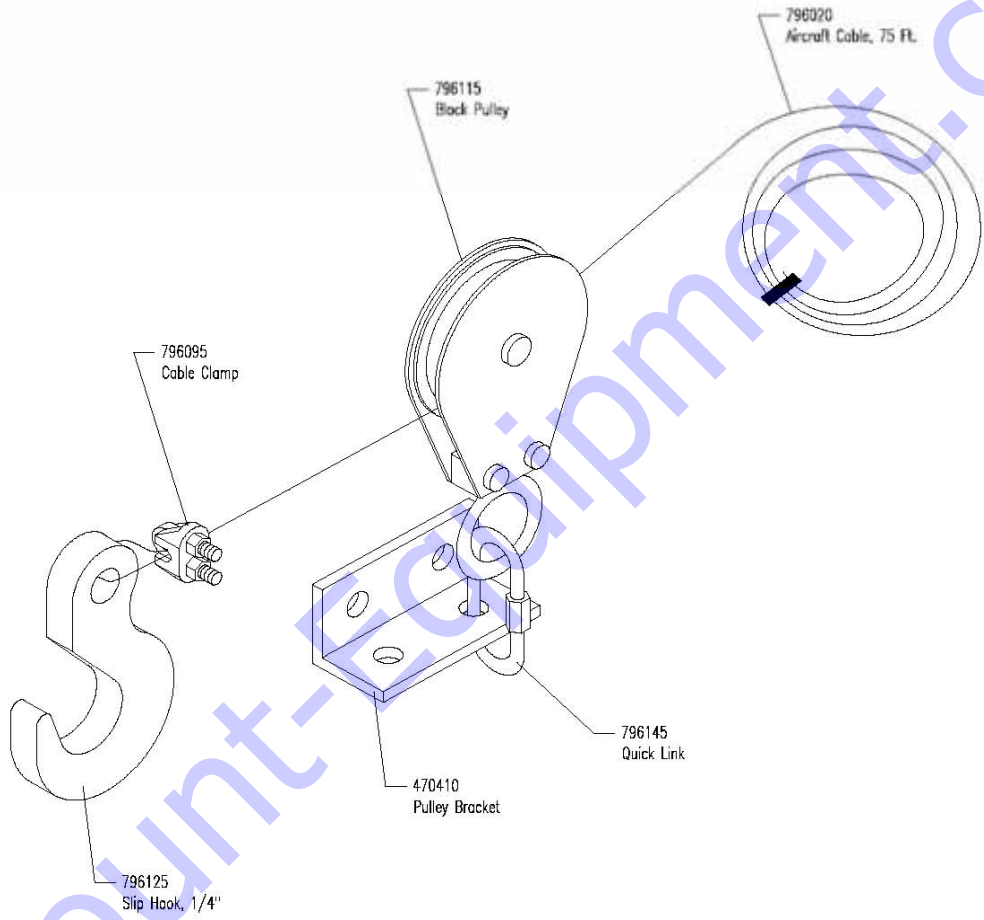

©Arnold Industries, Inc. 1997

Cable Assembly P/N 108480

Created: 8-18-97

By: WW

Revised: a) d)
 b) e)
 c) f)

Document: Screed-P14

VIBRATORY SCREED INSTRUCTION MANUAL & PARTS BOOK

	Model:	Screed/Super/Standard	Page: 15
	Title:	Hydraulic Tank Assembly	

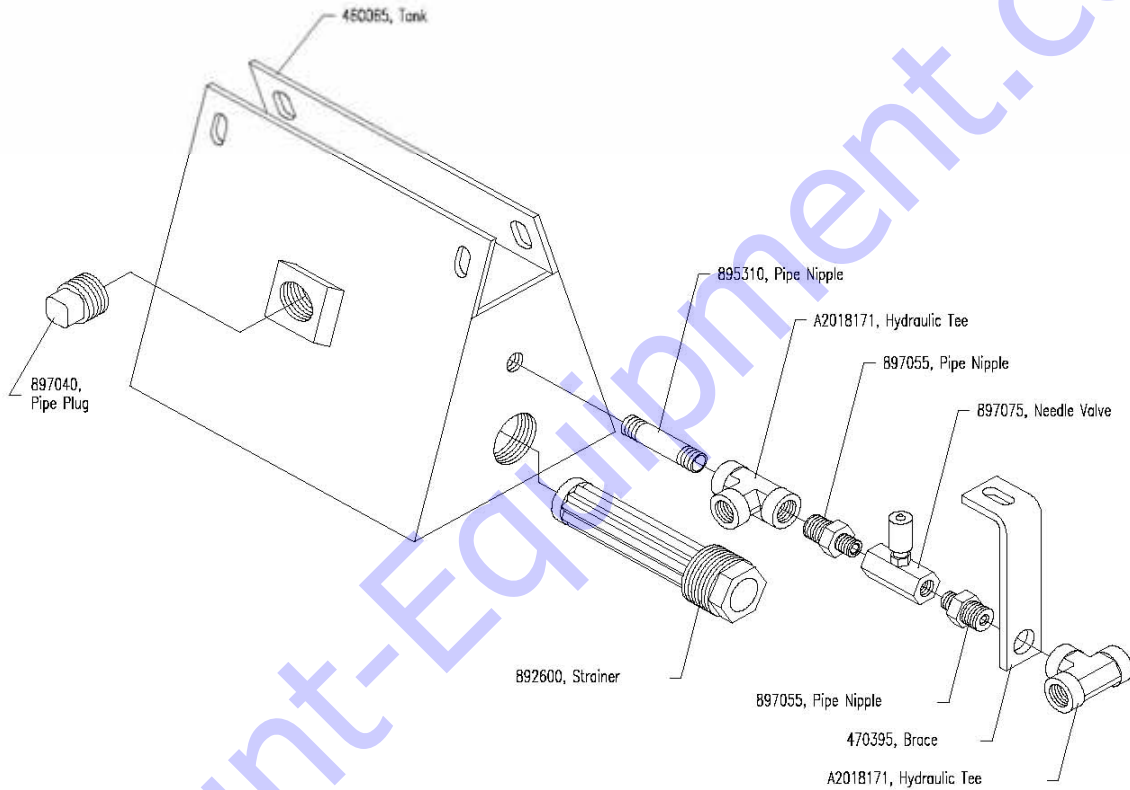

©Amida Industries, Inc. 1997

Created:	8-14-97	Revised:	a)	d)	Document: Screed-P15
By:	WW		b)	e)	
			c)	f)	

VIBRATORY SCREED INSTRUCTION MANUAL & PARTS BOOK



Model:	Screed/Super/Standard
Title:	Self-Propelled Shaft Assy.

Page:	16
-------	----

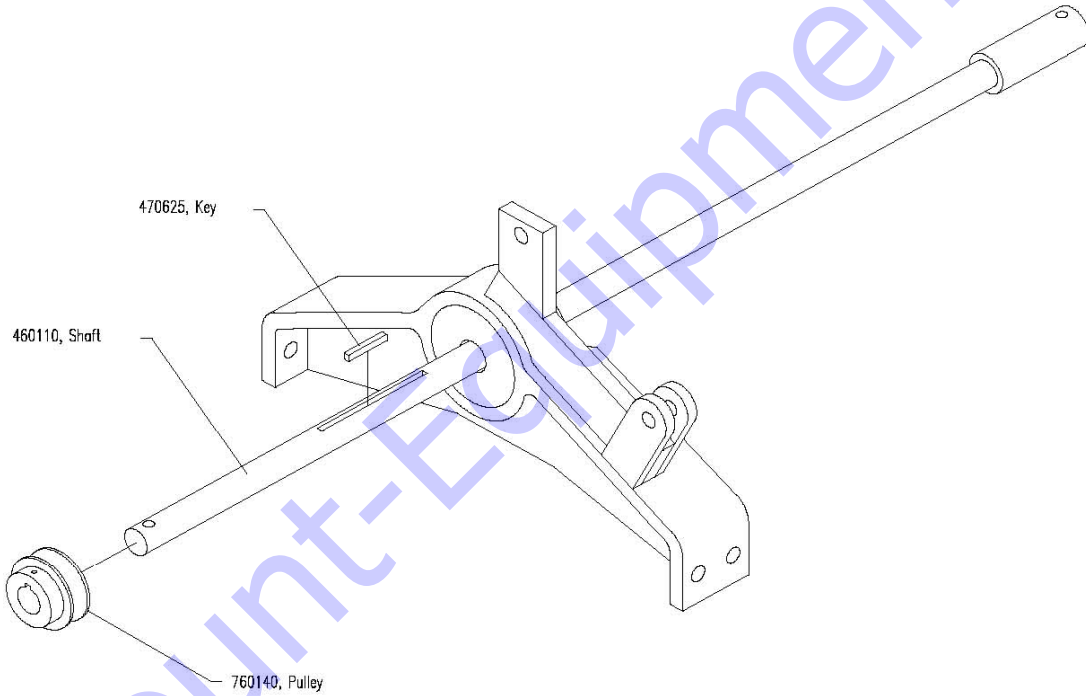

©Amvco Industries, Inc. 1997

Created:	8-20-97	Revised:	a)	d)	Document:
By:	WW		b)	e)	Screed-P16
			c)	f)	

VIBRATORY SCREED INSTRUCTION MANUAL & PARTS BOOK



Model: Screed/Super/Standard
 Title: Turnbuckle Assembly

Page: 17

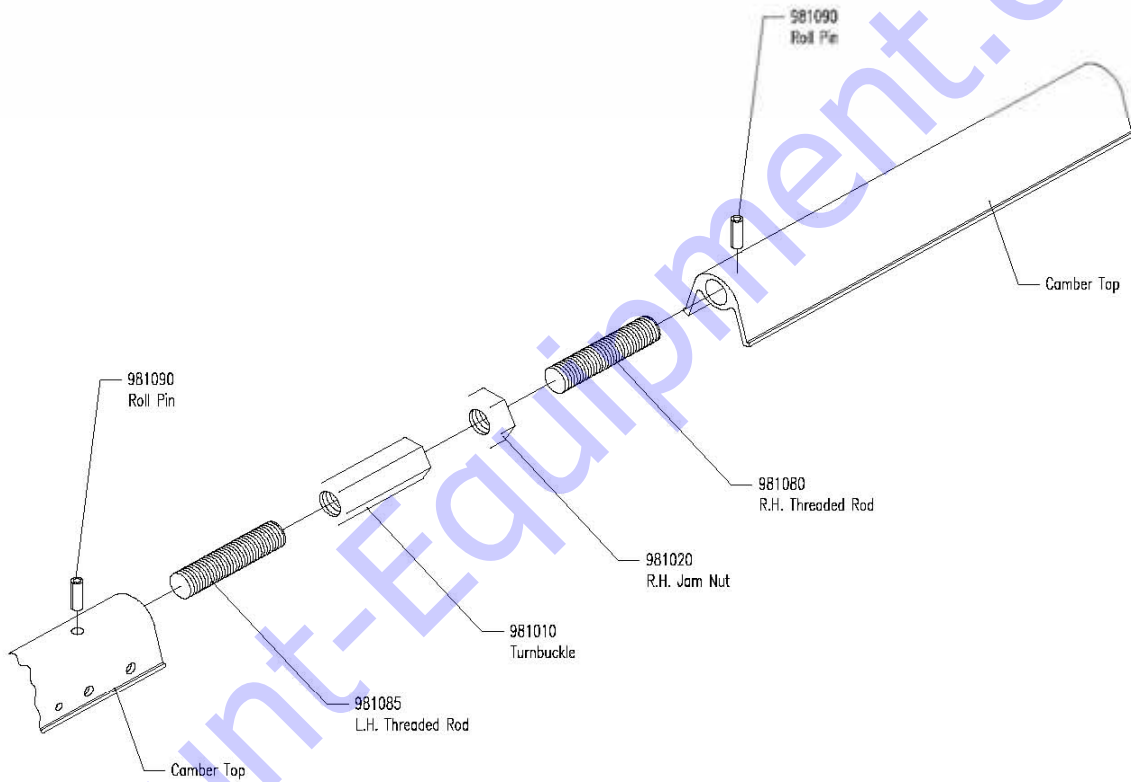

©Amida Industries, Inc. 1997

940260, Turnbuckle Assembly

Created: 8-18-97
 By: WW

Revised: a) 2-4-98 d)
 b) e)
 c) f)

Document: Screed-P17

VIBRATORY SCREED INSTRUCTION MANUAL & PARTS BOOK



Model:	Screed/Super/Standard
Title:	Pillow Block Bearing Assembly

Page: 18

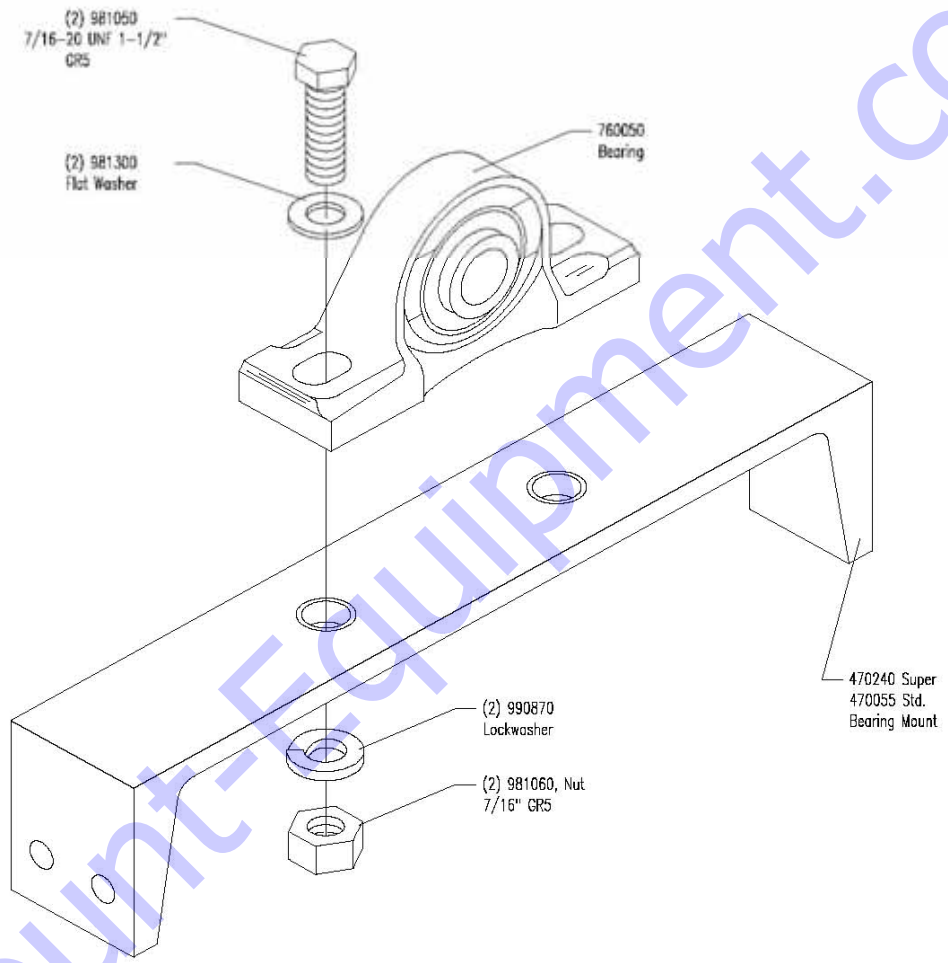

©Amvco Industries, Inc. 1997

108265, Complete Assembly

Created: 8-18-97
By: WW

Revised: a) 11-21-97 d)
b) 2-4-98 e)
c) f)

Document: Screed-P18

VIBRATORY SCREED INSTRUCTION MANUAL & PARTS BOOK



Model: Screed/Super/Standard
 Title: Cast Bearing Assy.

Page: 19

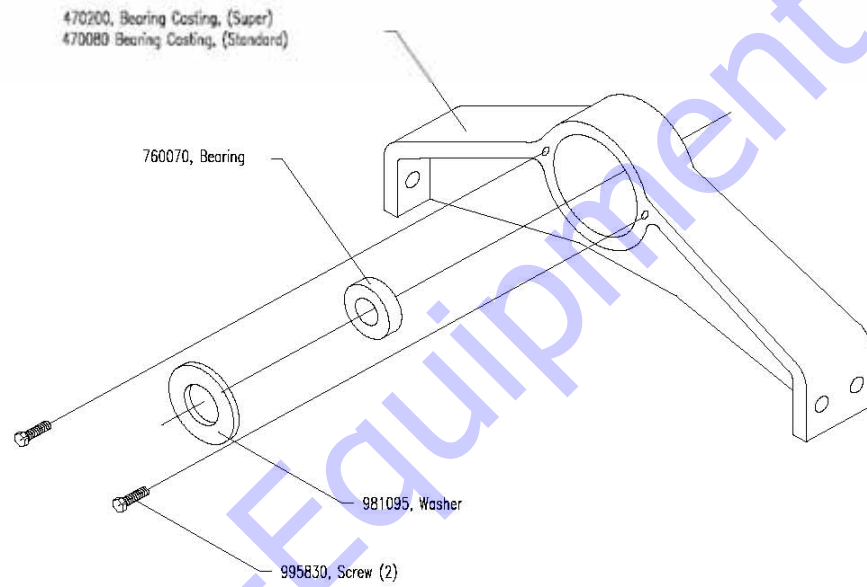

©Amida Industries, Inc. 1997

Created: 8-20-97

By: WW

Revised: a) d)
 b) e)
 c) f)

Document: Screed-P19

VIBRATORY SCREED INSTRUCTION MANUAL & PARTS BOOK



Model: Screed/Super/Standard
 Title: Connecting Hardware

Page: 20

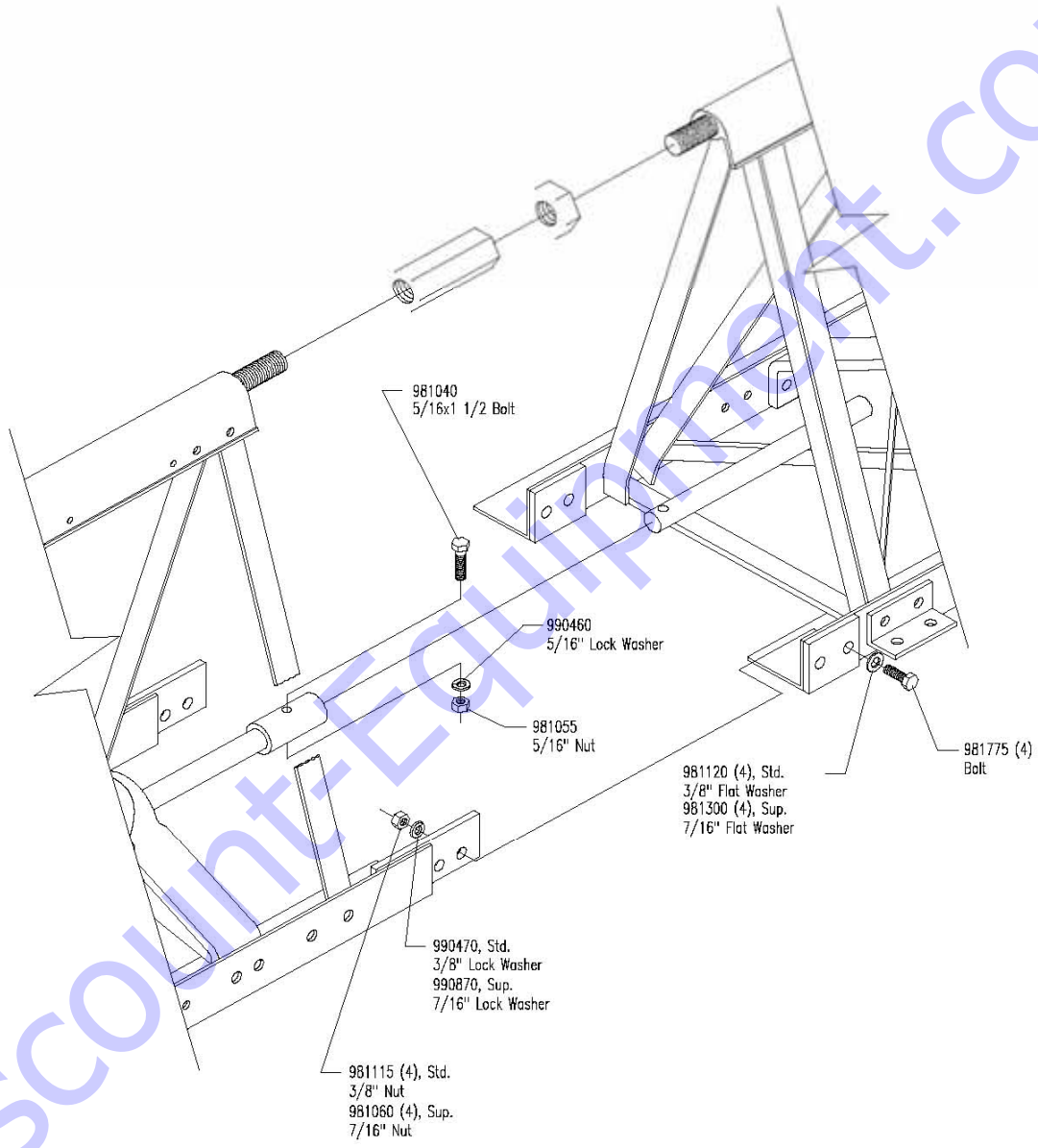

©Amica Industries, Inc. 1997

940220, Sup.
Bolt Bag Kit
940230, Std.
Bolt Bag Kit

Created: 8-18-97
 By: WW

Revised: a) 11-21-97 d)
 b) 2-4-98 e)
 c) f)

Document: Screed-P20

VIBRATORY SCREED INSTRUCTION MANUAL & PARTS BOOK

	Model: Screed/Super/Standard	Page: 21
	Title: Hand Winch Assembly	

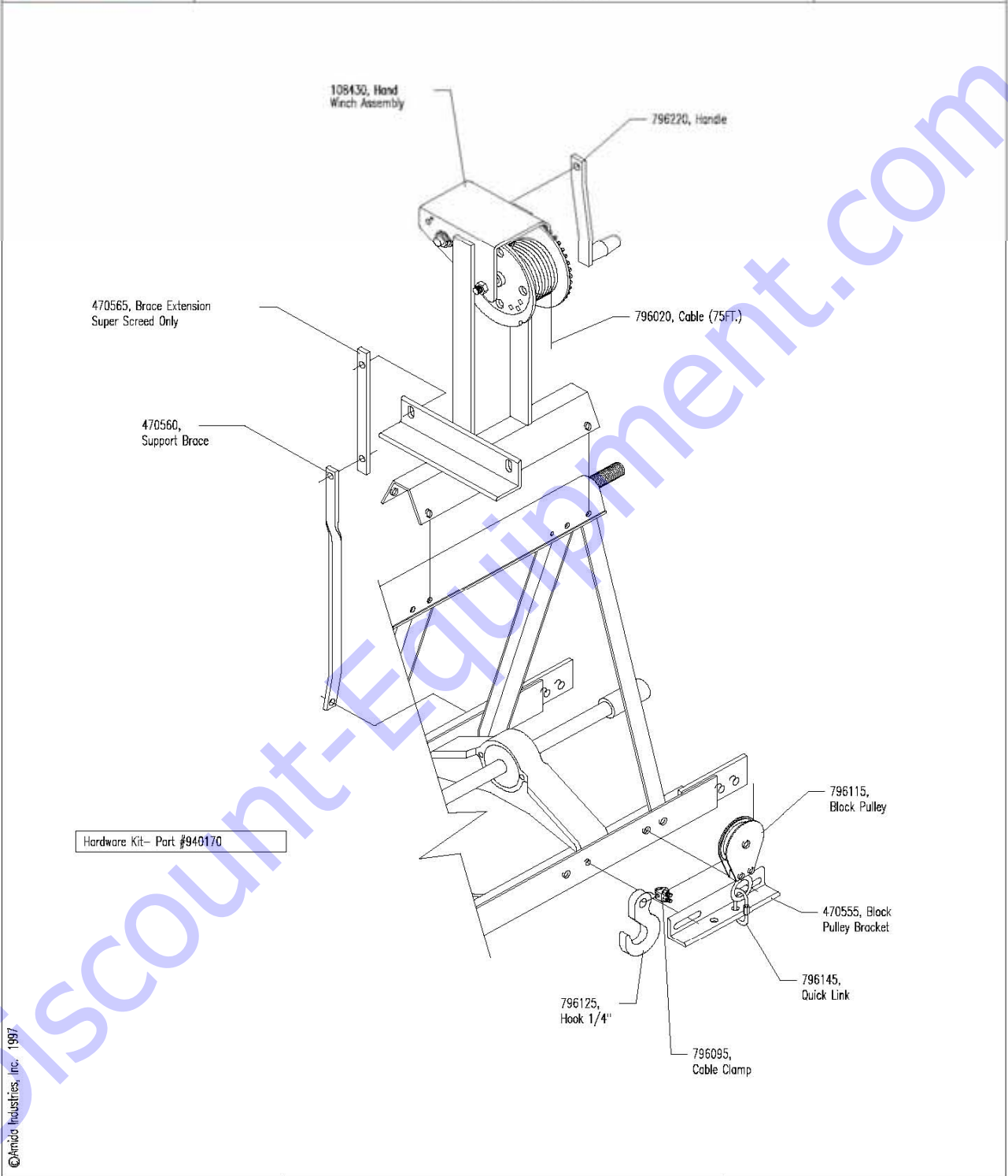

Created: 8-21-97	Revised: a) d)	Document: Screed-P21
By: WW	b) e)	
	c) f)	

©Armed Industries, Inc. 1997

Discount-Equipment.com

VIBRATORY SCREED INSTRUCTION MANUAL & PARTS BOOK

	Model:	Screed/Super/Standard	Page:	22
	Title:	End Adaptor Assy.		

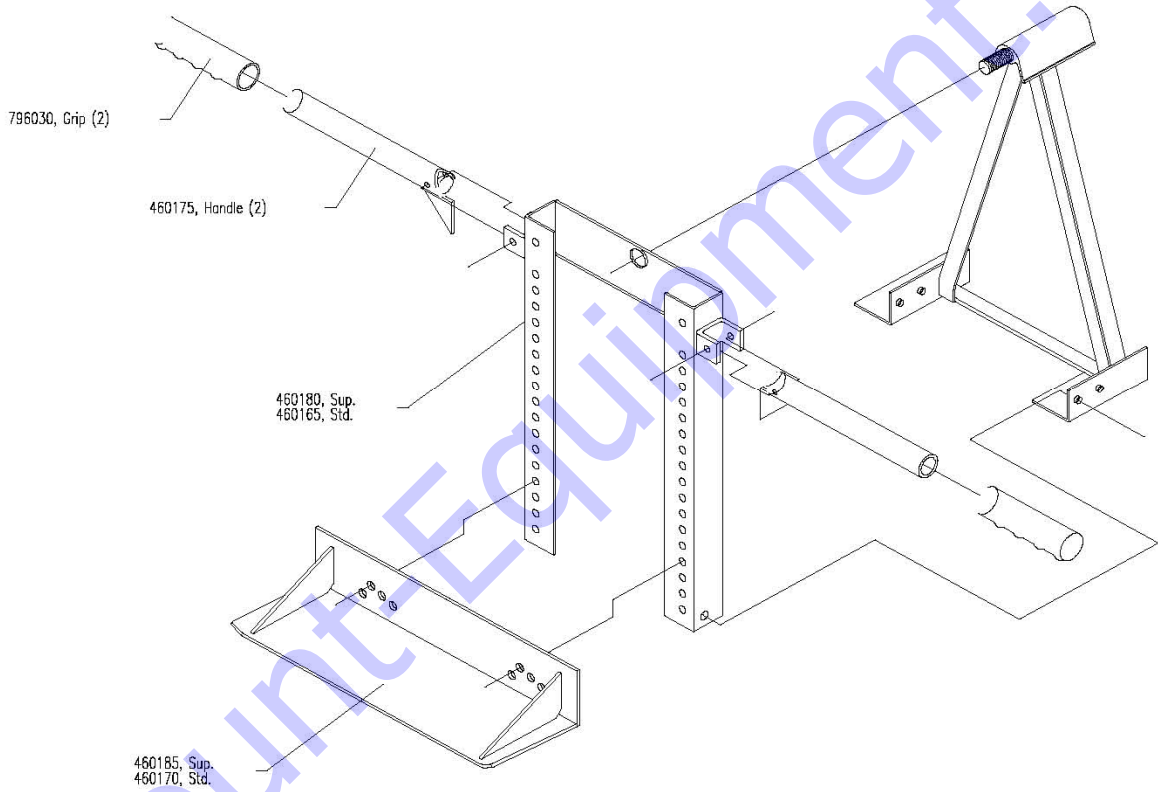

©Amido Industries, Inc. 1997

Created:	8-21-97	Revised:	a)	d)	Document:	Screed-P22
By:	WW		b)	e)		
			c)	f)		

PARTS FINDER

**Search Website
by Part Number**



**Search Manual
Library For Parts
Manual & Lookup Part
Numbers – Purchase
or Request Quote**

**Can't Find Part or
Manual? Request Help
by Manufacturer,
Model & Description**

Discount-Equipment.com is your online resource for quality parts & equipment.

Florida: **561-964-4949** Outside Florida TOLL FREE: **877-690-3101**

Need parts?

Click on this link: <http://www.discount-equipment.com/category/5443-parts/> and choose one of the options to help get the right parts and equipment you are looking for. Please have the machine model and serial number available in order to help us get you the correct parts. If you don't find the part on the website or on one of the online manuals, please fill out the request form and one of our experienced staff members will get back to you with a quote for the right part that your machine needs.

We sell worldwide for the brands: Genie, Terex, JLG, MultiQuip, Mikasa, Essick, Whiteman, Mayco, Toro Stone, Diamond Products, Generac Magnum, Airman, Haulotte, Barreto, Power Blanket, Nifty Lift, Atlas Copco, Chicago Pneumatic, Allmand, Miller Curber, Skyjack, Lull, Skytrak, Tsurumi, Husquvarna Target, Stow, Wacker, Sakai, Mi-T-M, Sullair, Basic, Dynapac, MBW, Weber, Bartell, Bennar Newman, Haulotte, Ditch Runner, Menegotti, Morrison, Contec, Buddy, Crown, Edco, Wyco, Bomag, Laymor, EZ Trench, Bil-Jax, F.S. Curtis, Gehl Pavers, Heli, Honda, ICS/PowerGrit, IHI, Partner, Imer, Clipper, MMD, Koshin, Rice, CH&E, General Equipment, Amida, Coleman, NAC, Gradall, Square Shooter, Kent, Stanley, Tamco, Toku, Hatz, Kohler, Robin, Wisconsin, Northrock, Oztec, Toker TK, Rol-Air, APT, Wylie, Ingersoll Rand / Doosan, Innovatech, Con X, Ammann, Mecalac, Makinex, Smith Surface Prep, Small Line, Wanco, Yanmar