

### ENGINE SYSTEM

- Kubota® D1105-E3BG1-MGM-1
- Diesel fueled
- EPA Tier 4
- 3 cylinder
- 1.12 L displacement
- Liquid cooled
- Power @ 1,800 rpm – HP (kW):
  - Prime: 13.5 (10.07)
  - Standby: 15.4 (11.48)

### Fuel System

- Polyethylene tank – 56.4 gal (213.5 L) usable fuel volume
- Fuel consumption – gal/hr (L/hr):
  - 100% load: 0.814 gph (3.08 Lph)\*
- Exterior fill port diameter: 3.5 in (88.9 mm)
- Fuel filter with replaceable element

### Cooling System

- Air filter: Dry type cartridge

### Lubrication System

- Oil filter: Full flow, spin-on type
- 1,000-hr service interval\*

*\*Results based on engine manufacturer and field test data after 100-hour engine break-in period and may vary based on factors including age and maintenance of equipment, environmental conditions and fuel density. Consult the Owner's Manual for fuel and maintenance recommendations.*

### GENERATOR

- 60 Hz engine/generator
- Marathon Electric® brushless
- Up to 8 kW output
- 120/240 VAC, 50/25 A
- ± 6% capacitor voltage regulation

### CONTROLS

- Engraved, aluminum punched and anodized control panel
- 4-position key activated switch (off, run, glow, start)
- Digital hour meter
- Automatic low oil/high temperature shutdown system



**TO PURCHASE THIS PRODUCT PLEASE CONTACT US**



**Equipment Financing and  
Extended Warranties Available**



**Discount-Equipment.com is your online resource for  
commercial and industrial quality parts and equipment sales.**

**561-964-4949**

**visit us on line @ [www.discount-equipment.com](http://www.discount-equipment.com)**

Select an option below to find your Equipment

**Search by Manufacturer**

**Search by Product Type**

**Request a Quote**

We sell worldwide for the brands: Genie, Terex, JLG, MultiQuip, Mikasa, Essick, Whiteman, Mayco, Toro Stone, Diamond Products, Generac Magnum, Airman, Haulotte, Barreto, Power Blanket, Nifty Lift, Atlas Copco, Chicago Pneumatic, Allmand, Miller Curber, Skyjack, Lull, Skytrak, Tsurumi, Husquvarna Target, Stow, Wacker, Sakai, Mi-T-M, Sullair, Basic, Dynapac, MBW, Weber, Bartell, Bennar Newman, Haulotte, Ditch Runner, Menegotti, Morrison, Contec, Buddy, Crown, Edco, Wyco, Bomag, Laymor, EZ Trench, Bil-Jax, F.S. Curtis, Gehl Pavers, Heli, Honda, ICS/PowerGrit, IHI, Partner, Imer, Clipper, MMD, Koshin, Rice, CH&E, General Equipment, Amida, Coleman, NAC, Gradall, Square Shooter, Kent, Stanley, Tamco, Toku, Hatz, Kohler, Robin, Wisconsin, Northrock, Oztec, Toker TK, Rol-Air, APT, Wylie, Ingersoll Rand / Doosan, Innovatech, Con X, Ammann, Mecalac, Makinex, Smith Surface Prep, Small Line, Wanco, Yanmar

## FLOODLIGHTS

- Four [4] 1,100 watt metal halide
  - Lm/bare bulb: 132,000
  - Lm/fixture: 70,356
  - Total bare bulb lm: 528,000
  - Total fixture lm: 281,424
- Efficiency: 120 LPW
- Coverage: @ 0.5 ft-c: 39,241 ft<sup>2</sup> (3,646 m<sup>2</sup>)
- Oval aluminum reflector
- Tempered glass lens
- Silicone gaskets for moisture and dust protection
- Friction disc mounting for tool less positioning
- Individual floodlight On/Off switches
- Internal cabinet light storage

## ELECTRICAL SYSTEM

- 40A start trip breaker (ensures no-load condition exists at start-up)
- Floodlight circuits with sealed 15A breakers
- Ballast Indicator lights
- Convenience receptacles with individual breakers:
  - (2) 120 VAC 20 Amp GFCI duplex outlets (NEMA 5-20R type)
  - (1) 240 VAC, 30 A, twistlock outlet (NEMA L6-30R type)
- 440CCA CCA wet cell battery

## MAST

- Wind Rating: 65 mph (105 kph)
- Horizontal mast; 30 ft. (9.14 m) maximum extension, 3-section, tubular steel
- Dual winch system located at ergonomic height allowing single person operation
- Urethane guides on all sides of mast tubes
- Industrial black powder coat finish
- Automatic locking system in horizontal position for travel
- 1500 lb. (680 kg) self-breaking electric winch – easily raises mast vertically
- 359° ground-level rotation with locking system
- Coiled mast cord

## ENCLOSURE

- Steel enclosure – 14-gauge
  - UV & fade resistant, high temperature cured, white polyester powder paint
  - 68 dB(A) at 23 ft. (7 m) – prime power
- Stainless steel hinges on doors
- Multi-lingual operating/safety decals
- License plate holder with light
- Manual holder with operating manual
- Equipped with single lifting eye and fork pockets

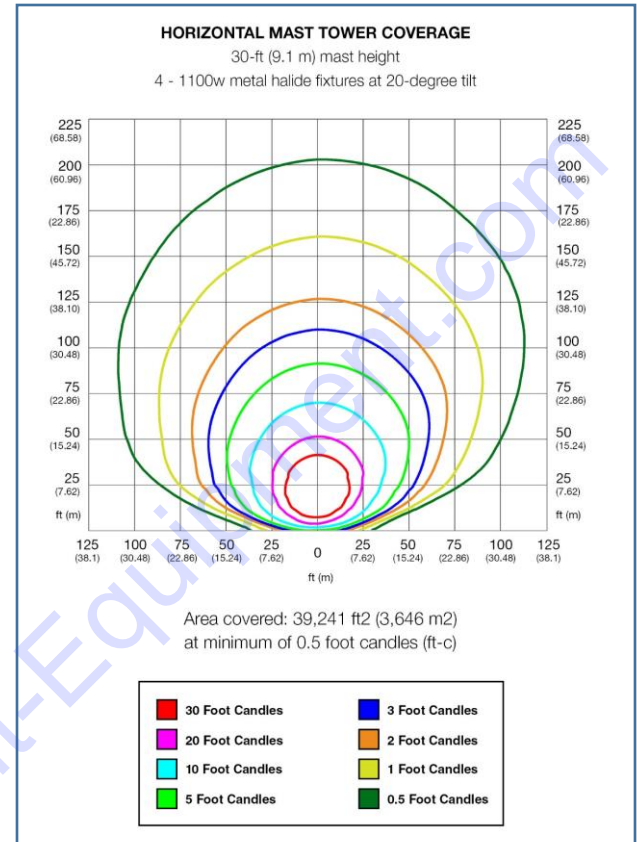

**TRAILER**

- Removable tongue – 48 in. (1219.20 mm) long
- (4) 2000 lb. (907.18 kg) adjustable leveling jacks – 4 point stance
- All jacks transport and lock in horizontal position for storage
- Side outriggers – 151 in. (3.84 m) span
- 7800 lb. (3538 kg) safety chains with spring loaded safety hooks
- Combo hitch: 2 in. (50.8 mm) ball hitch and 2.5 in. (63.5) pintle ring
- Single wall polyethylene fenders
- DOT approved tail, side, brake, and directional lights
  - Recessed rear lights
- 3500 lb. (1588 kg) leaf spring axle
- P205/75R15 – 6 ply
- 68.5 in. (1740 mm) axle span

**WEIGHT**

- Dry weight: 2121 lbs. (963 kg)
- Operating weight: 2524 lbs. (1145 kg)

**DIMENSIONS**

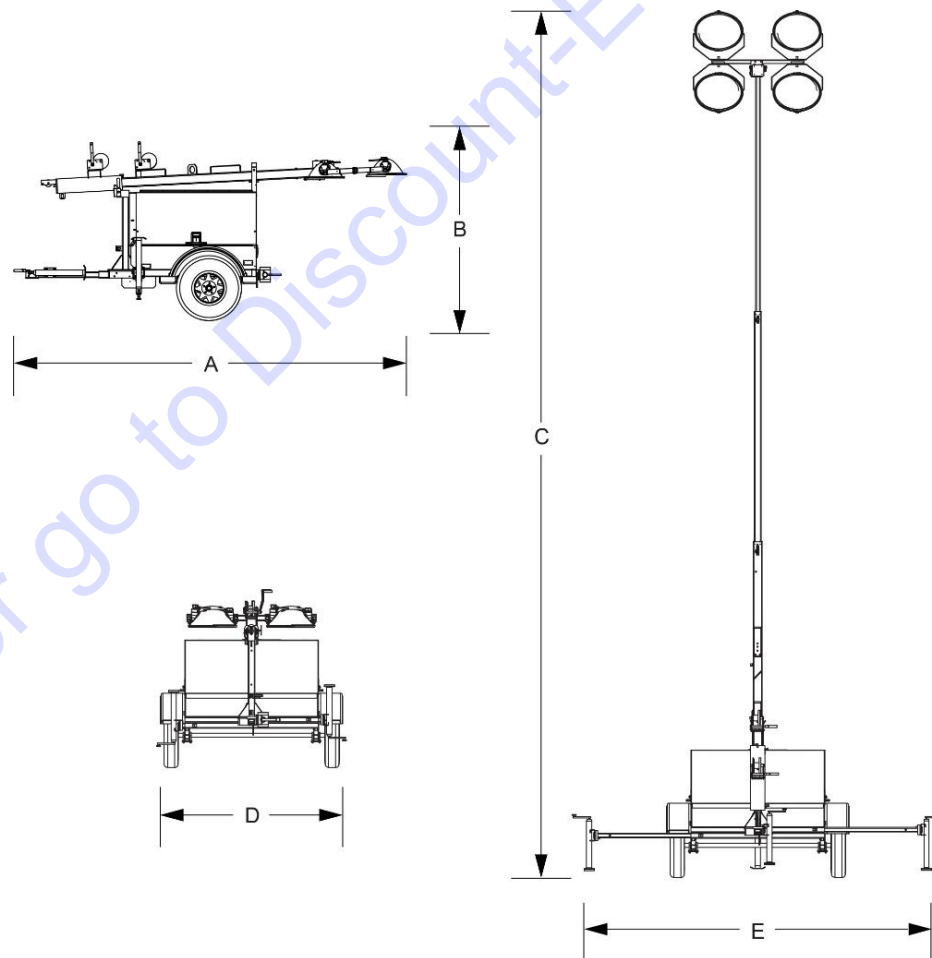

A	B	C	D	E
170 in (4.32 m)	72 in (1.83 m)	30 ft (9.14 m)	79 in (2 m)	151 in (3.56 m)

**OPTIONS**

- Digital Power Zone Controller
- Cold weather package options
- Canadian Package (CAN)
  - 60/40 coolant
  - Radiator hose heater
  - Heated fuel filter
  - 775CCA AGM sealed battery
  - Liquid containment
- Additional options available. Please contact a sales representative or the factory for current options.

**WARRANTY**

- 1 Year / Unlimited Hours
- 2 Years / 2000 Hours

**CERTIFICATIONS**

CSA Certified

To order go to [Discount-Equipment.com](http://Discount-Equipment.com)