

Owner's Manual
Light Tower

MLT4200IF4

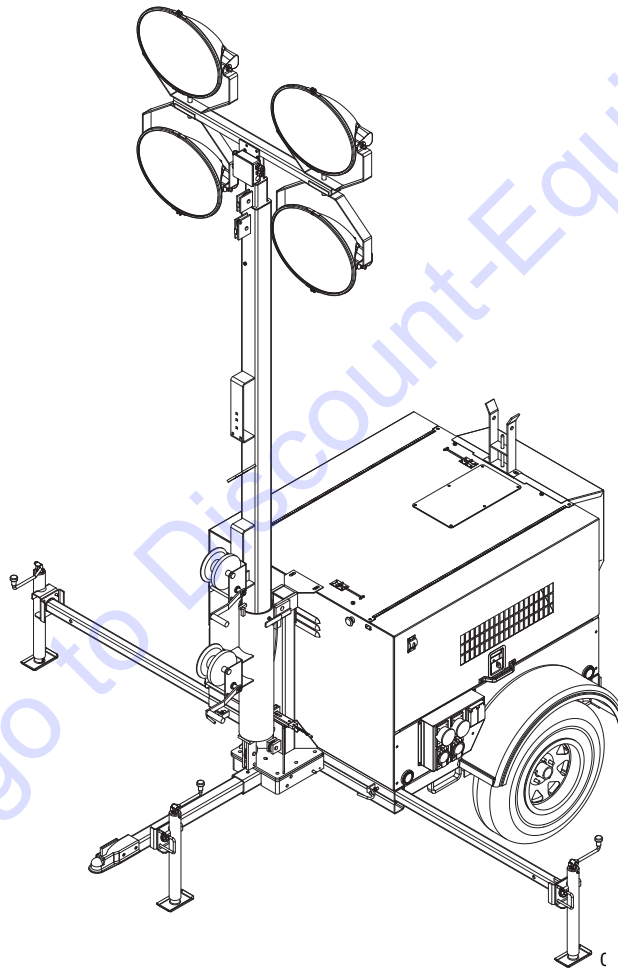

TO PURCHASE THIS PRODUCT PLEASE CONTACT US



**Equipment Financing and
Extended Warranties Available**



**Discount-Equipment.com is your online resource for
commercial and industrial quality parts and equipment sales.**

561-964-4949

visit us on line @ www.discount-equipment.com

Select an option below to find your Equipment

Search by Manufacturer

Search by Product Type

Request a Quote

We sell worldwide for the brands: Genie, Terex, JLG, MultiQuip, Mikasa, Essick, Whiteman, Mayco, Toro Stone, Diamond Products, Generac Magnum, Airman, Haulotte, Barreto, Power Blanket, Nifty Lift, Atlas Copco, Chicago Pneumatic, Allmand, Miller Curber, Skyjack, Lull, Skytrak, Tsurumi, Husquvarna Target, Stow, Wacker, Sakai, Mi-T-M, Sullair, Basic, Dynapac, MBW, Weber, Bartell, Bennar Newman, Haulotte, Ditch Runner, Menegotti, Morrison, Contec, Buddy, Crown, Edco, Wyco, Bomag, Laymor, EZ Trench, Bil-Jax, F.S. Curtis, Gehl Pavers, Heli, Honda, ICS/PowerGrit, IHI, Partner, Imer, Clipper, MMD, Koshin, Rice, CH&E, General Equipment, Amida, Coleman, NAC, Gradall, Square Shooter, Kent, Stanley, Tamco, Toku, Hatz, Kohler, Robin, Wisconsin, Northrock, Oztec, Toker TK, Rol-Air, APT, Wylie, Ingersoll Rand / Doosan, Innovatech, Con X, Ammann, Mecalac, Makinex, Smith Surface Prep, Small Line, Wanco, Yanmar

Use this page to record important information about your Light Tower

Unit Model Number	
Unit Serial Number	
Engine Model Number	
Engine Serial Number	
Generator Model Number	
Generator Serial Number	

Record the information found on your unit data label on this page. See unit serial number location ([Unit Serial Number Locations](#)). The label plate is affixed to the inside partition, to the left of the control panel console.

Engine and generator serial numbers are located on separate data plates affixed to the engine and generator respectively.

When contacting a Generac Mobile Products Authorized Service Dealer (GMP ASD) about parts and service, always supply the complete model number and serial number of the unit.

Operation and Maintenance: Proper maintenance and care of the Light Tower ensures a minimum number of problems and keeps operating expenses at a minimum. It is the operator's responsibility to perform all safety checks, to verify that all maintenance for safe operation is performed promptly, and to have the equipment checked periodically by a Generac Mobile Products Authorized Service Dealer. Normal maintenance, service and replacement of parts are the responsibility of the owner/operator and, as such, are not considered defects in materials or workmanship within the terms of the warranty. Individual operating habits and usage may contribute to the need for additional maintenance or service.

⚠ WARNING

California Proposition 65. Engine exhaust and some of its constituents are known to the state of California to cause cancer, birth defects, and other reproductive harm. (000004)

⚠ WARNING

California Proposition 65. This product contains or emits chemicals known to the state of California to cause cancer, birth defects, and other reproductive harm. (000005)

Table of Contents

Section 1: Safety Rules & General Information

Introduction	1
Read This Manual Thoroughly	1
How to Obtain Service	1
Safety Rules	1
General Hazards	2
Explosion and Fire Hazards	2
Trailer Hazards	2
Electrical Hazards	3
Battery Hazards	3
Fuel Hazards	4
Engine Safety	4
Operating Safety	4
Positioning the Unit	4
Starting the Unit	4
Raising and Lowering the Mast	5
Service Safety	5
Towing Safety	6
Hitch and Coupling	6
Running Lights	6
Wheels and Tires	6
Safe Towing Techniques	6
Reporting Trailer Safety Defects	6
Safety and Operating Decals	7

Section 2: General Information

Specifications	11
Unit Dimensions	12
Unit Serial Number Locations	13
Component Locations	14
Control Panel	15
Power Zone—DLA	16
Controller Features and Functions	16
Operator Screens	17

Section 3: Operation

Light Tower Setup	21
Prestart Checklist	22

Raising the Mast	23
Preparing for Start-Up	24
Select AUTO or MANUAL Mode	24
Configure for Intended Use	24
Emergency Stop Switch	24
Engine Break-In Requirements	24
Manually Starting the Unit	25
Auto (Remote) Starting of the Unit	25
Light Operation	25
Engine Derating	26
Wet Stacking	26
Voltage Regulation	26
Customer Convenience Outlets	26
Remote Start Terminal Block	27
Transfer Switch	27
AUTO Exercise Timer	28
Shutting Down the Unit	29
Automatic Shutdown	29
Lower Radiator Hose Heater (If Equipped)	30
Use and Maintenance	30
Lowering the Mast	30
Removing the Lights for Transportation	30
Towing the Unit	31
Lifting the Unit	32

Section 4: Maintenance

Emissions Information	33
Daily Walk-Around Inspection	33
General Maintenance	33
Preparing for Service	33
Cleaning the Unit	33
Inspecting the Unit	33
Basic Maintenance Schedule	34
Resetting the Maintenance Alarms	35
Winch Use, Operation and Maintenance	35
Prior to Use	35
Operation	35
Maintenance	35

Jack Maintenance36
Trailer Wheel Bearings36

Section 5: Troubleshooting

General Troubleshooting37
Troubleshooting the Lights38

Section 6: Wiring Diagrams

**Mast Junction Box Wiring and Light
Connections39**
AC Wiring40
AC Wiring—Receptacle Panel41
**AC Wiring—Receptacle Panel
Options (1 of 2)42**
**AC Wiring—Receptacle Panel Options
(2 of 2)43**
DC Wiring44
DC Wiring for Optional Equipment45
Trailer Lights Wiring46

Section 1: Safety Rules & General Information

Introduction

Thank you for purchasing a Generac Mobile Products LLC product. This unit has been designed to provide high performance, efficient operation, and years of use when maintained properly.

The information in this manual is accurate based on products produced at the time of publication. The manufacturer reserves the right to make technical updates, corrections, and product revisions at any time without notice.

Read This Manual Thoroughly



WARNING

Consult Manual. Read and understand manual completely before using product. Failure to completely understand manual and product could result in death or serious injury. (000100a)

The owner is responsible for proper maintenance and safe use of the equipment. Comply with regulations the Occupational Safety and Health Administration (OSHA) has established, or with equivalent standards. Also, verify that the unit is applied, used, and maintained in accordance with the manufacturer's instructions and recommendations. Do nothing that might alter safe application/usage and render the unit in noncompliance with the aforementioned codes, standards, laws, and regulations.

Save these instructions for future reference. This manual contains important instructions for the unit that should be followed during setup, operation and maintenance of the unit and battery. ALWAYS supply this manual to any individual that will use this machine.

Safety Rules

The manufacturer cannot anticipate every possible circumstance that might involve a hazard. The warnings in this manual, and on tags and decals affixed to the unit are, therefore, not all inclusive. If using a procedure, work method or operating technique that the manufacturer does not specifically recommend, verify that it is safe for others. Also make sure the procedure, work method or operating technique utilized does not render the equipment unsafe.

Throughout this publication, and on tags and decals affixed to the unit, DANGER, WARNING, CAUTION and NOTE blocks are used to alert personnel to special instructions about a particular operation that may be hazardous if performed incorrectly or carelessly. Observe them carefully. Their definitions are as follows:

DANGER

Indicates a hazardous situation which, if not avoided, will result in death or serious injury.

(000001)

WARNING

Indicates a hazardous situation which, if not avoided, could result in death or serious injury.

(000002)

CAUTION

Indicates a hazardous situation which, if not avoided, could result in minor or moderate injury.

(000003)

NOTE: Notes contain additional information important to a procedure and will be found within the regular text of this manual.

These safety alerts cannot eliminate the hazards that they indicate. Common sense and strict compliance with the special instructions while performing the action or service are essential to preventing accidents.

General Hazards



⚠ DANGER

Asphyxiation. Running engines produce carbon monoxide, a colorless, odorless, poisonous gas. Carbon monoxide, if not avoided, will result in death or serious injury. (000103)



⚠ WARNING

Hearing Loss. Hearing protection is recommended when using this machine. Failure to wear hearing protection could result in permanent hearing loss. (000107)



⚠ WARNING

Moving Parts. Keep clothing, hair, and appendages away from moving parts. Failure to do so could result in death or serious injury. (000111)



⚠ WARNING

Hot Surfaces. When operating machine, do not touch hot surfaces. Keep machine away from combustibles during use. Hot surfaces could result in severe burns or fire. (000108)

⚠ WARNING

Only qualified service personnel may install, operate, and maintain this equipment. Failure to follow proper installation requirements could result in death, serious injury, and damage to equipment or property. (000182)

⚠ WARNING

Risk of injury. Do not operate or service this machine if not fully alert. Fatigue can impair the ability to service this equipment and could result in death or serious injury. (000215)



⚠ WARNING

Risk of burns. Allow engine to cool before draining oil or coolant. Failure to do so could result in death or serious injury. (000139)

Explosion and Fire Hazards



⚠ DANGER

Explosion and Fire. Fuel and vapors are extremely flammable and explosive. Add fuel in a well ventilated area. Keep fire and spark away. Failure to do so will result in death or serious injury. (000105)



⚠ WARNING

Risk of Fire. Unit must be positioned in a manner that prevents combustible material accumulation underneath. Failure to do so could result in death or serious injury. (000147)



⚠ WARNING

Risk of Fire. Hot surfaces could ignite combustibles, resulting in fire. Fire could result in death or serious injury. (000110)

Trailer Hazards

⚠ WARNING

Trailer must be securely coupled to the hitch and the chains correctly attached. Uncoupled or unchained towing could result in death or serious injury. (000233)

⚠ WARNING

Do not operate this unit while transporting. Doing so could result in death or serious injury. (000231)

⚠ WARNING

Crushing hazard. Verify unit is properly secured and on level ground. An unsecured unit can suddenly roll or move, causing death or serious injury. (000234a)

⚠ WARNING

Property or Equipment Damage. Tighten wheel lug nuts after first 50 miles to factory specifications. Failure to do so could result in death, serious injury, property or equipment damage. (000235)

Electrical Hazards



⚠ DANGER

Electrocution. In the event of electrical accident, immediately shut power OFF. Use non-conductive implements to free victim from live conductor. Apply first aid and get medical help. Failure to do so will result in death or serious injury. (000145)



⚠ DANGER

Electrocution. Water contact with a power source, if not avoided, will result in death or serious injury.

(000104)



⚠ DANGER

Electrocution. Contact with bare wires, terminals, and connections while generator is running will result in death or serious injury.

(000144)



⚠ DANGER

Electrocution. Verify electrical system is properly grounded before applying power. Failure to do so will result in death or serious injury.

(000152)



⚠ DANGER

Electrocution. Do not wear jewelry while working on this equipment. Doing so will result in death or serious injury.

(000188)



⚠ DANGER

Electrocution. DO NOT use the unit if electrical cord is cut or worn through. Doing so will result in death or serious injury.

(000263a)

Battery Hazards



⚠ DANGER

Electrocution. Do not wear jewelry while working on this equipment. Doing so will result in death or serious injury.

(000188)



⚠ WARNING

Explosion. Batteries emit explosive gases while charging. Keep fire and spark away. Wear protective gear when working with batteries. Failure to do so could result in death or serious injury.

(000137a)



⚠ WARNING

Explosion. Do not dispose of batteries in a fire. Batteries are explosive. Electrolyte solution can cause burns and blindness. If electrolyte contacts skin or eyes, flush with water and seek immediate medical attention.

(000162)



⚠ WARNING

Risk of burn. Do not open or mutilate batteries. Batteries contain electrolyte solution which can cause burns and blindness. If electrolyte contacts skin or eyes, flush with water and seek immediate medical attention.

(000163a)

⚠ WARNING

Environmental Hazard. Always recycle batteries at an official recycling center in accordance with all local laws and regulations. Failure to do so could result in environmental damage, death or serious injury.

(000228)

Always recycle batteries in accordance with local laws and regulations. Contact your local solid waste collection site or recycling facility to obtain information on local recycling processes. For more information on battery recycling, visit the Battery Council International website at: <http://batteryCouncil.org>

Fuel Hazards



⚠ DANGER

Explosion and fire. Fuel and vapors are extremely flammable and explosive. No leakage of fuel is permitted. Keep fire and spark away. Failure to do so will result in death or serious injury. (000192)



⚠ DANGER

Risk of fire. Allow fuel spills to completely dry before starting engine. Failure to do so will result in death or serious injury. (000174)

- **DO NOT** fill fuel tank near an open flame, while smoking, or while engine is running. **DO NOT** fill tank in an enclosed area with poor ventilation.
- **DO NOT** operate with the fuel tank cap loose or missing.

Engine Safety

Internal combustion engines present special hazards during operation and fueling. Failure to follow the safety guidelines described below could result in severe injury or death. Read and follow all safety alerts described in the engine operator's manual. A copy of this manual was supplied with the unit when it was shipped from the factory.

- **DO NOT** run engine indoors or in an area with poor ventilation. Make sure engine exhaust cannot seep into closed rooms or ventilation equipment.
- **DO NOT** clean air filter with gasoline or other types of low flash point solvents.
- **DO NOT** operate the unit without a functional exhaust system.
- Shut the engine down if any of the following conditions exist during operation:
 - Abnormal change in engine speed.
 - Loss of electrical output.
 - Equipment connected to the unit overheats.
 - Sparking occurs.
 - Engine misfires or there is excessive engine/generator vibration.
 - Protective covers are loose or missing.
 - Ambient air temperature is above 120°F (49°C).

Operating Safety

Positioning the Unit



⚠ DANGER

High Voltage. Verify area above unit is clear of overhead wires and obstructions. Contact with high-voltage power lines will result in death or serious injury. (000260a)



⚠ WARNING

Burn hazard. Never operate lights with a damaged or missing lens cover. Lamps are hot and pressurized while in use. Unprotected lamps can shatter, causing severe injury. (000277)

- The area immediately surrounding the unit should be dry, clean, and free of debris.
- Position and operate the unit on a firm, level surface.
- If the unit is equipped with a frame grounding stud, follow the National Electrical Code (NEC), state, and local regulations when connecting.

Starting the Unit



⚠ DANGER

Electrocution. **DO NOT** use the unit if electrical cord is cut or worn through. Doing so will result in death or serious injury. (000263a)

⚠ WARNING

Equipment damage. Do not attempt to start or operate a unit in need of repair or scheduled maintenance. Doing so could result in serious injury, death, or equipment failure or damage. (000291)

Raising and Lowering the Mast



⚠️ WARNING

Electrocution. Do not set up or operate this unit if severe weather is expected. Lightning strikes can kill or cause severe injury even if you are not touching the unit. (000296)



⚠️ WARNING

> 60 mph Do not set up the unit if high winds are expected. High winds can cause the unit to tip or fall, causing severe injury or machine damage. (000297)

⚠️ WARNING

Personal injury or equipment damage. Do not raise or lower the mast while the unit is operating. Doing so can break the lenses and cause the lamps to shatter. (000279)

⚠️ WARNING

Personal Injury. Stop immediately if the mast hangs up or the winch cable develops slack. Excess slack could cause the mast to collapse, resulting in personal injury or equipment damage. (000265)

⚠️ WARNING

Tipping hazard. Extend the outriggers and level the unit before raising the mast. Keep the outriggers extended while the mast is up. Failure to do so could cause the unit to tip and fall and could result in death or serious injury. (000266)



⚠️ WARNING

Burn hazard. Lamps become extremely hot while in use. Allow 10–15 minutes for cooling before handling or lowering mast. Touching a hot lens or fixture can cause severe burns. (000278)

- Keep area around the unit clear of people while raising and lowering the mast.
- **ALWAYS** lower the mast when not in use.
- The tower extends up to 30 ft (9.14 m). Verify area above trailer is open and clear of overhead wires and obstructions.
- If for any reason any part of mast hangs up or winch cable develops slack while raising or lowering tower, STOP immediately! Contact a Generac Mobile Products Authorized Service Dealer.
- **NEVER** remove safety pin or pull mast locking pin while tower is up.

Service Safety

This unit uses high voltage circuits capable of causing serious injury or death. Only a qualified and licensed electrician should troubleshoot or repair problems occurring in this equipment.

- Before servicing the unit, verify the Control Power switch and circuit breakers are in the OFF (O) position, and the negative (-) terminal on the battery is disconnected. **DO NOT** perform even routine service (oil/filter changes, cleaning, etc.) unless all electrical components are shut down.
- **ALWAYS** use extreme caution when servicing this unit in damp conditions. Do not service the unit if your skin or clothing is wet. Do not allow water to collect around the base of the unit.
- **DO NOT** wash the unit with high pressure hoses, power washers, or steam cleaners. Water may collect in the unit, causing damage to electrical parts.
- Replace all missing and hard to read decals. Decals provide important operating instructions and warn of dangers and hazards.
- Wear heavy leather gloves when handling winch cables. Never let cables slip through bare hands.
- Only use mild soap and water to clean the lens covers. Other chemicals may damage the lens covers.
- Make sure slings, chains, hooks, ramps, jacks and other types of lifting devices are attached securely and have enough weight-bearing capacity to lift or hold the equipment safely. Always remain aware of the position of other people around you when lifting the equipment.

Towing Safety

Towing a trailer requires care. Both the trailer and vehicle must be in good condition and securely fastened to each other to reduce the possibility of an accident. Some states require that large trailers be registered and licensed. Contact your local Department of Transportation office to check on license requirements for your particular unit.

Hitch and Coupling

- Verify the hitch and coupling on the towing vehicle are rated equal to, or greater than, the trailer's Gross Vehicle Weight Rating (GVWR).
- Verify the trailer hitch and the coupling are compatible. Make sure the coupling is securely fastened to the vehicle.
- **DO NOT** tow trailer using defective parts. Inspect the hitch and coupling for wear or damage.
- Connect safety chains in a crossing pattern under the tongue.
- Before towing the trailer, verify the weight of the trailer is equal across all tires. On trailers with adjustable height hitches, adjust the angle of the trailer tongue to keep the trailer as level as possible.

Running Lights

Verify directional and brake lights on the trailer are connected and working properly

Wheels and Tires

- Check trailer tires for wear and proper inflation.
- Verify wheel lug nuts are present and tightened to the specified torque.

Safe Towing Techniques

- Practice turning, stopping and backing up in an area away from heavy traffic prior to transporting the unit.
- Maximum recommended speed for highway towing is 45 mph (72 km/h). Recommended off-road towing speed is 10 mph (16 km/h) or less, depending on terrain.
- When towing, maintain extra space between vehicles and avoid soft shoulders, curbs and sudden lane changes.

Reporting Trailer Safety Defects

If you believe your trailer has a defect which could cause a crash or could cause injury or death, you should immediately inform the National Highway Traffic Safety Administration (NHTSA) in addition to notifying Generac Mobile Products LLC.

If NHTSA receives similar complaints, it may open an investigation; and if it finds that a safety defect exists in a group of vehicles, it may order a recall and remedy campaign. However, NHTSA cannot become involved in an individual problem between you, your dealer, or Generac Mobile Products LLC.

To contact NHTSA, you may either call the Auto Safety Hotline toll-free at 1-888-327-4236 (TTY:1-800-424-9153), go to <http://www.safercar.gov>; or write to:

Administrator
NHTSA
1200 New Jersey Avenue S.E.
Washington, DC 20590

You can also obtain other information about motor vehicle safety from <http://www.safercar.gov>.

Safety and Operating Decals

See [Figure 1-1](#) through [Figure 1-3](#). This unit features numerous safety and operating decals. These decals provide important operating instructions and warn of dangers and hazards. The following diagrams illustrate decal locations and descriptions.

Replace any missing or hard-to-read decals and use care when washing or cleaning the unit.

29	Danger–Diesel Fuel, Asphyxiation, No Open Flames, Consult Manual
30	Ultra Low Sulfur Fuel Only
31	Warning–Radiator Is Hot During Operation
32	Warning–Moving Parts, Hot Surface
33	Warning–Hot Surface

ID	Description
1	Danger–Lower Tower Before Tilting Mast
2	Lift Points
3	Do Not Remove Bolt
4	Crushing Hazard
5	Secure Mast Before Lifting or Towing
6	Tie-Down Point
7	Danger–Electrocution, Consult Manual
8	Warning–Tipping Hazard
9	Instruction–Align Before Tilting Mast Down
10	Danger–Secure Mast
11	Grounding Stud
12	Receptacle Panel Circuit Breaker Locations
13	Warning–Crushing Hazard
14	Warning–Ultraviolet Radiation
15	Warning–High Winds and Electrical Storms
16	Instructions–Set Up
17	Instructions–Starting and Stopping the Generator
18	Warning–Moving Parts and Hot Surface
19	Consult Manual
20	Instruction–Disconnect Battery Before Servicing
21	Remote Start Terminal Locations
22	Danger–High Voltage, Consult Manual
23	Danger–Overhead Power Lines
24	Use Caution When Raising or Lowering Mast
25	Instruction–Towing Instructions
26	Primary Filter
27	Secondary Filter
28	High Voltage

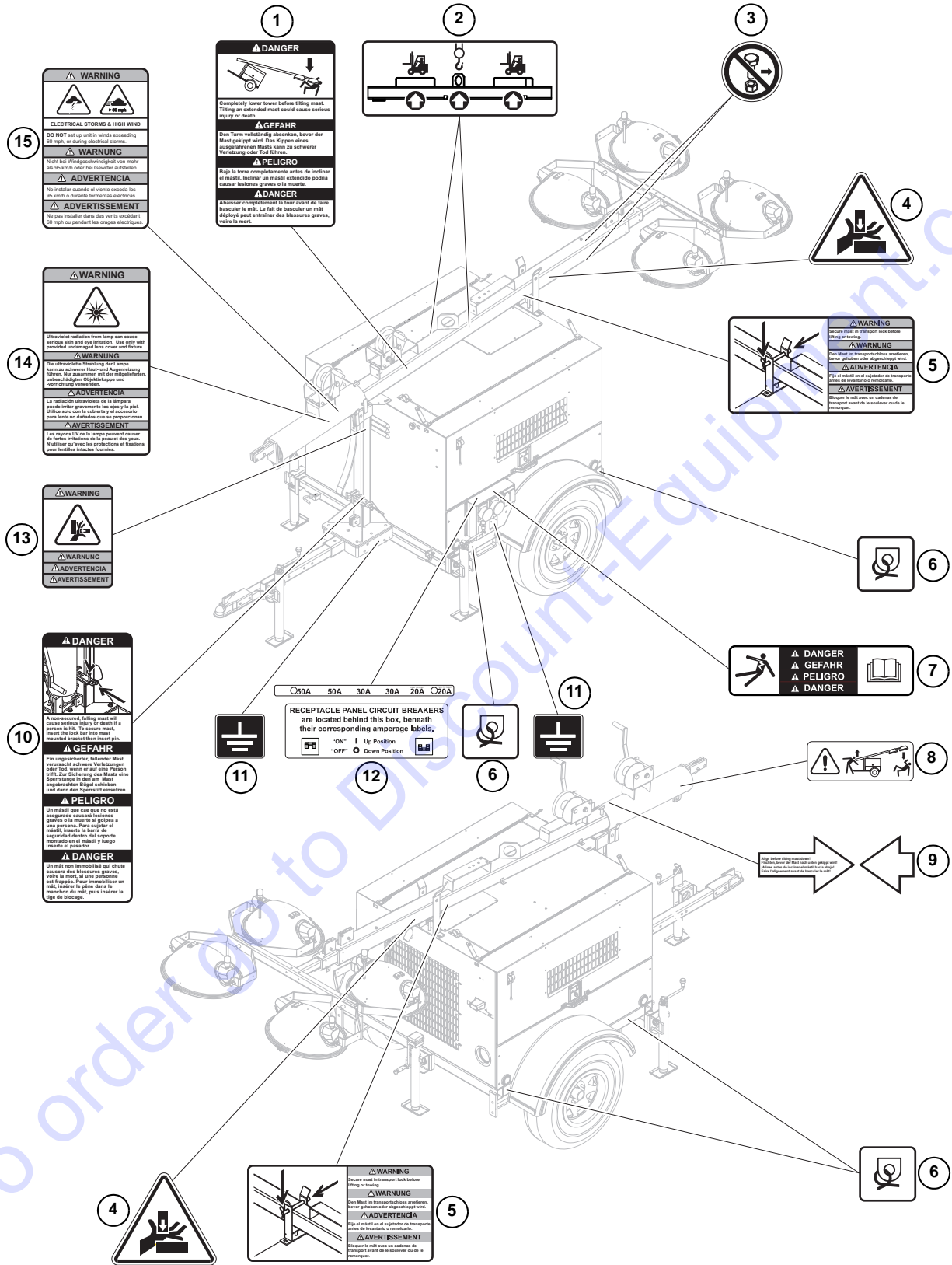

Figure 1-1. Decals - External

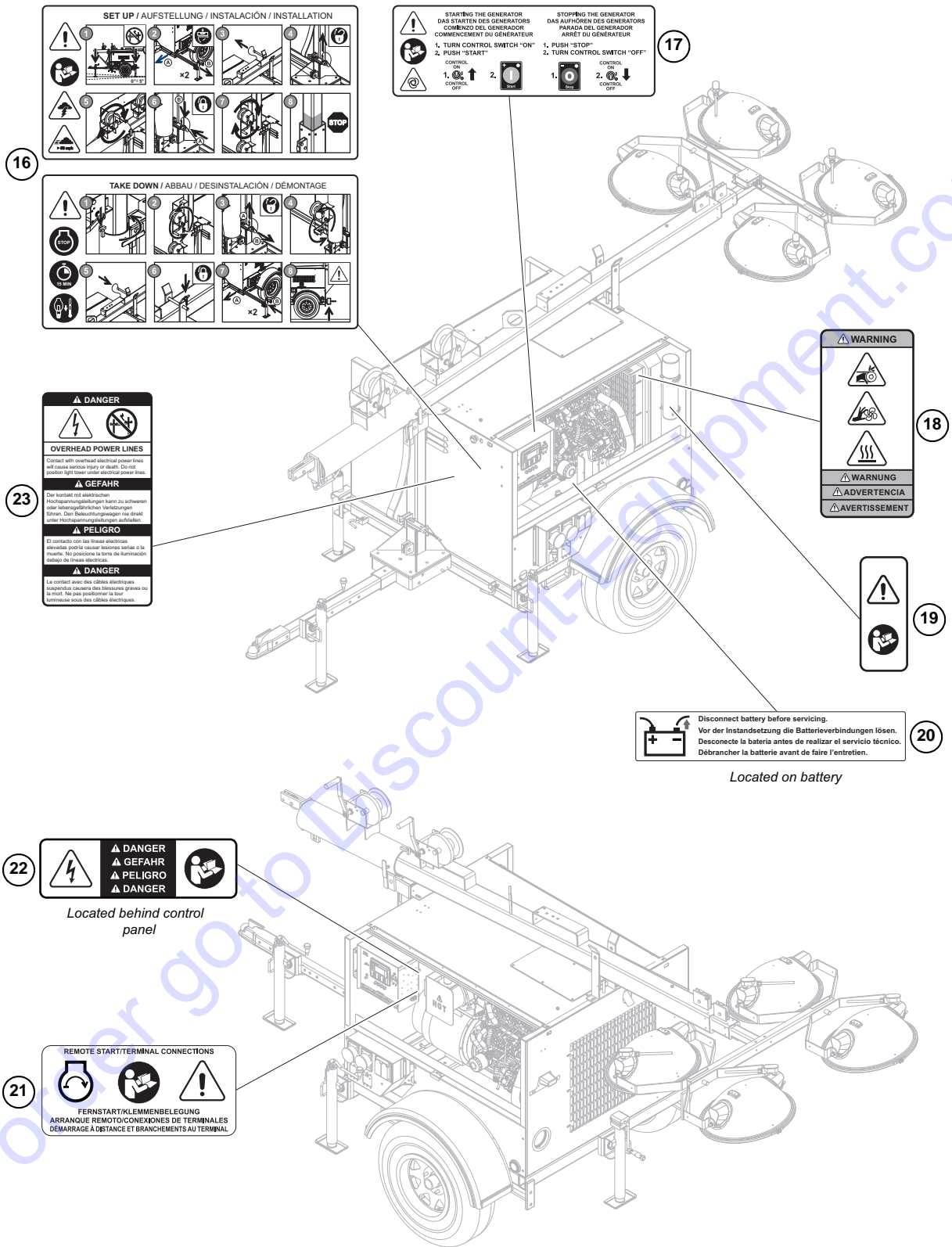

Figure 1-2. Decals - Left Side and Interior

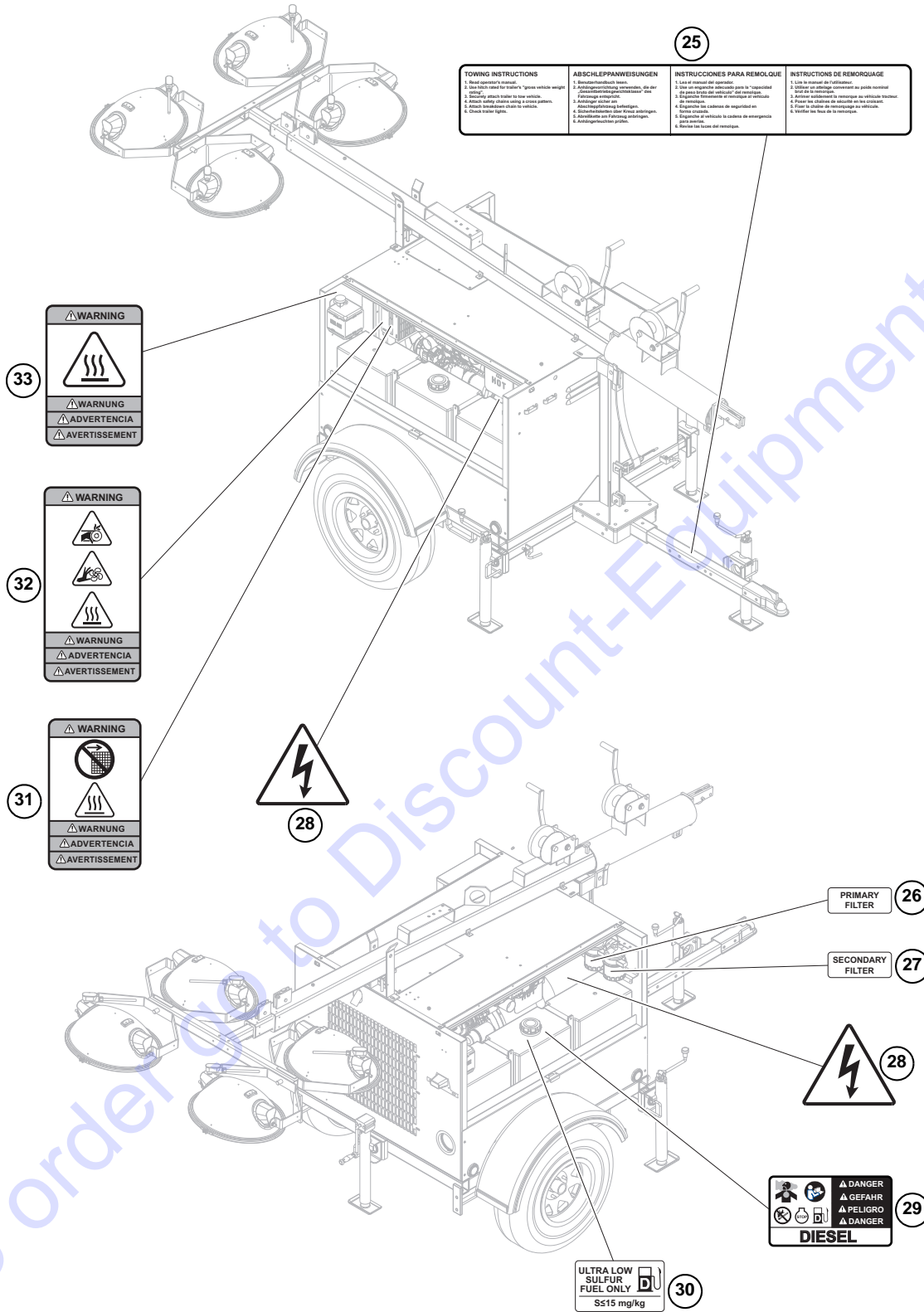

Figure 1-3. Decals - Right Side and Interior

Section 2: General Information

Specifications

DESCRIPTION	UNITS	MLT4200IF4
Engine		
Make/Brand	—	Isuzu
Model	—	4LE2TAGV-03
EPA Tier	—	4F
Horsepower - prime	hp (kW)	36.2 (27.0)
Horsepower - standby	hp (kW)	40.2 (30.0)
Operating Speed	rpm	1800
Displacement	in ³ (L)	133 (2.18)
Cylinders	qty	4
Fuel Consumption—100%	gph (Lph)	2.1 (7.8)
Battery Type—Group Number	—	24
Battery Voltage	quantity per unit	12V (1)
Battery Rating	CCA-hour	720
Generator		
Make/Brand	—	Marathon Electric
Model	—	334CSA3028
Type, Insulation	—	Brushless, H
Output	kW (kVA)	20.0 (20.0)
Output Voltage	volts	120/240, single phase
Output Amperes 120V (240V)	amperes	167 (83)
Frequency Hz	Hertz	60
Power Factor	—	1 (1Ø)
Sound (23ft at prime)	dB (A)	70
Weights		
Dry Weight	lbs (kg)	2105 (955)
Operating Weight	lbs (kg)	2395 (1086)
Capacities		
Fuel Tank Volume	gal (L)	50 (190)
Usable Fuel Volume	gal (L)	50 (190)
Coolant (including engine)	qt (L)	12 (11.3)
Oil (including filter)	qt (L)	8.0 (7.6)
Maximum Run Time	hours	23.8
AC Distribution		
Circuit Breaker Size	amperes	100
Voltage Regulation	—	+/-1%
Voltages Available 1Ø	—	120, 240
Lighting		
Lighting Type	—	Metal Halide
Ballast Type	—	Coil & Core
Lumens	—	440,000-462,000
Coverage	acres (m ²)	5 - 7 (20,234 - 28,328)
Trailer		
Number of Axles		1
Capacity - Axle Rating	lbs (kg)	3000 (1361)
Tire Size	in	15
Hitch—Standard	—	2" Ball
Maximum Tire Pressure	psi	50
<i>Specifications are subject to change without notice.</i>		

Unit Dimensions

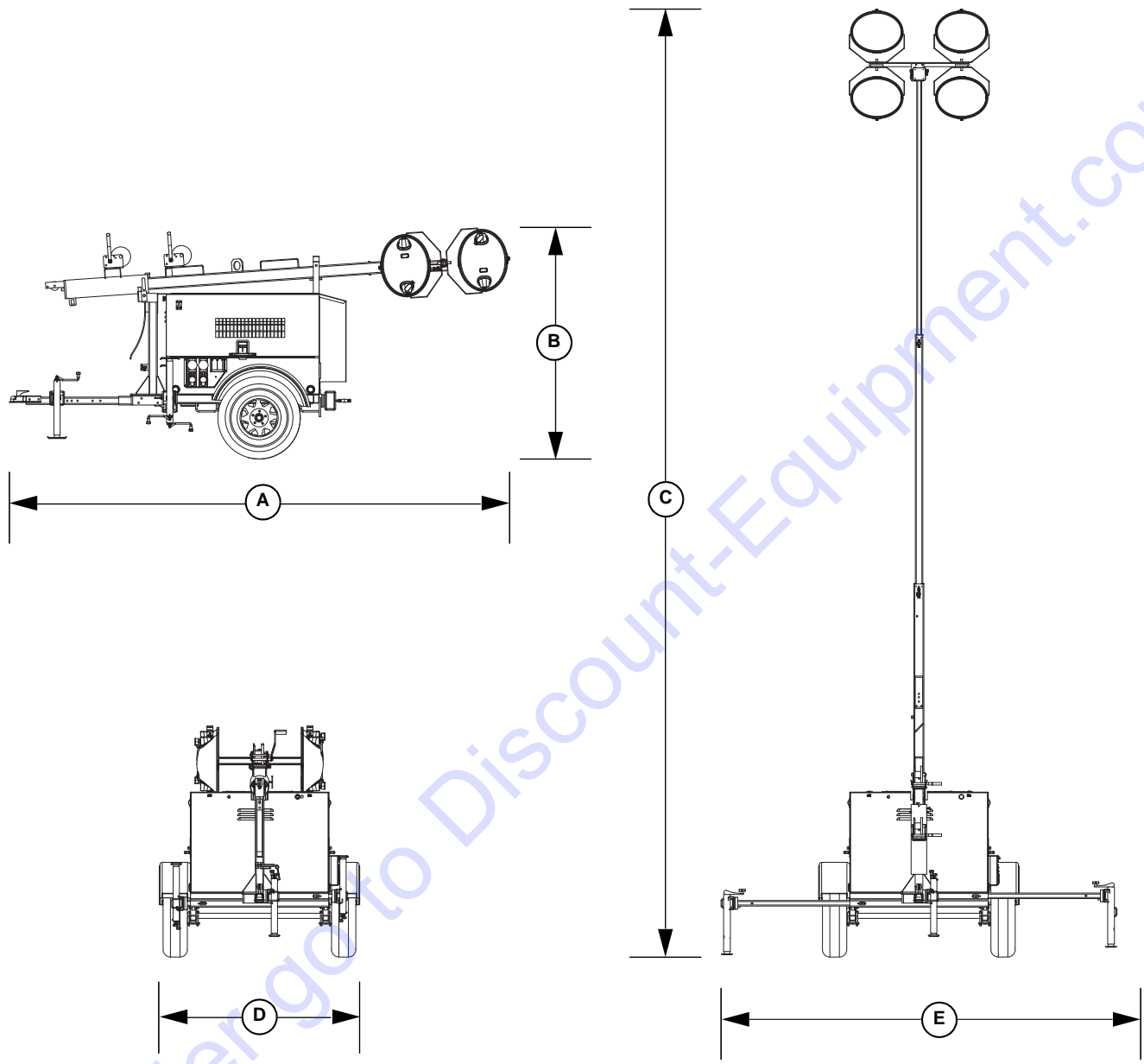

003976

Figure 2-1. Unit Dimensions

	A	B	C	D	E
MLT4200IF4	115 in. (2.92 m)	70 in. (1.78 m)	30 ft (9.14 m)	68 in. (1.73 m)	140 in. (3.56 m)

Specifications are subject to change without notice.

Unit Serial Number Locations

Refer to the illustration to locate the unit ID tag and Vehicle Identification Number (VIN) tag on the unit. Important information, such as the unit serial number, model number, VIN and tire loading information are found on these tags. Record the information from these tags so it is available if the tags are lost or damaged. When ordering parts or requesting assistance, you may be asked to provide this information.

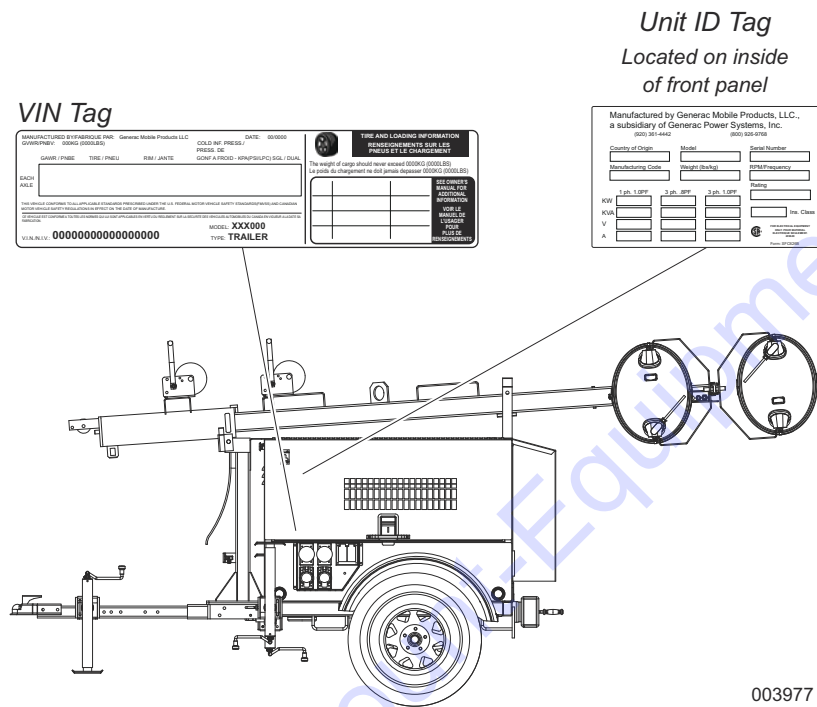

Figure 2-2. Serial Number Locations

Component Locations

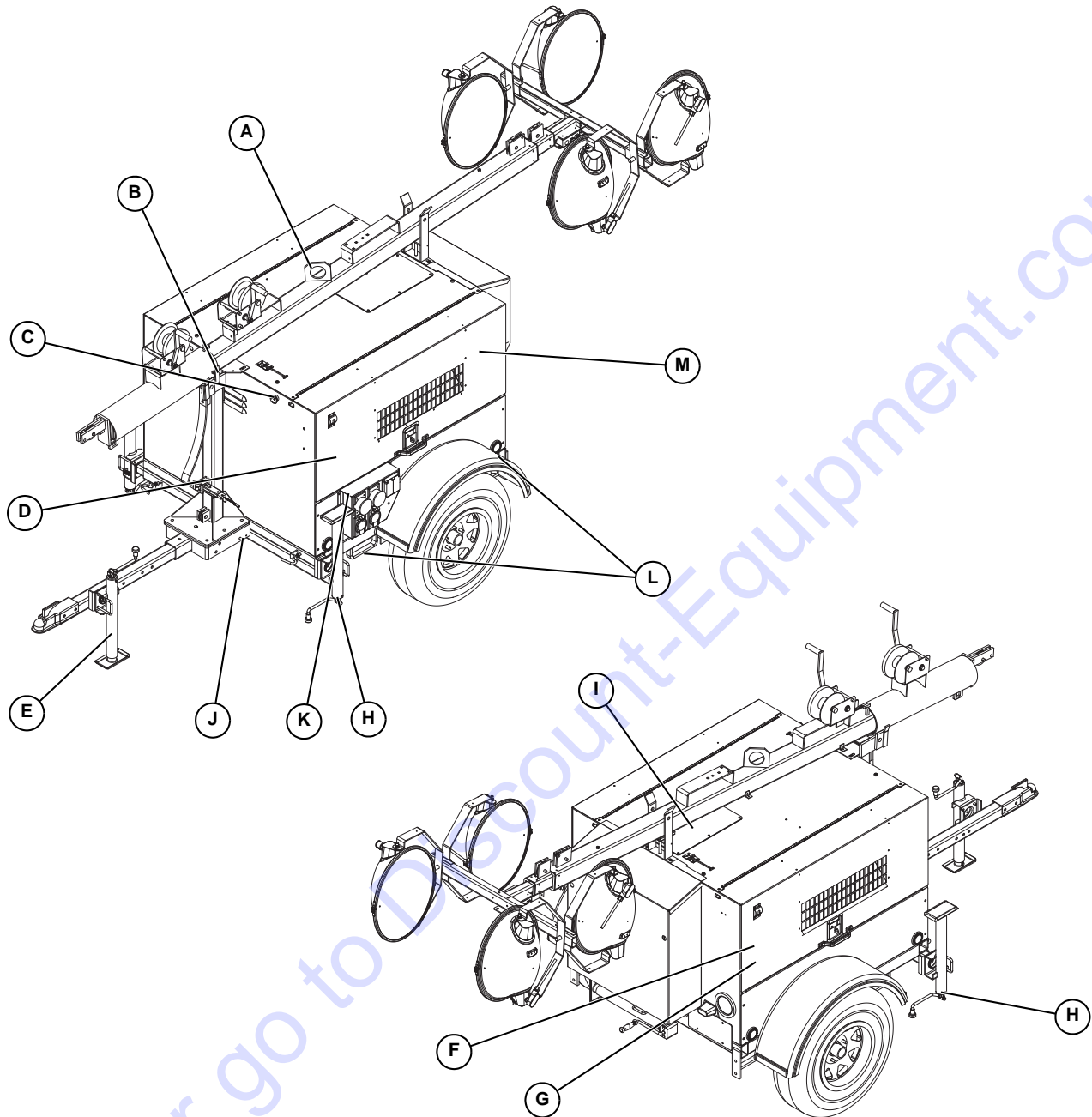

Figure 2-3. Component Locations

003978

- | | | | |
|---|-----------------------|---|-------------------|
| A | Central Lift Point | H | Leveling Jack |
| B | Mast Rotation Knob | I | Radiator Access |
| C | Emergency Stop Switch | J | Grounding Stud |
| D | Control Panel Access | K | Receptacle Panel |
| E | Tongue Jack | L | Fork Lift Pockets |
| F | Engine Access | M | Engine Access |
| G | Fuel Fill Access | | |

Control Panel

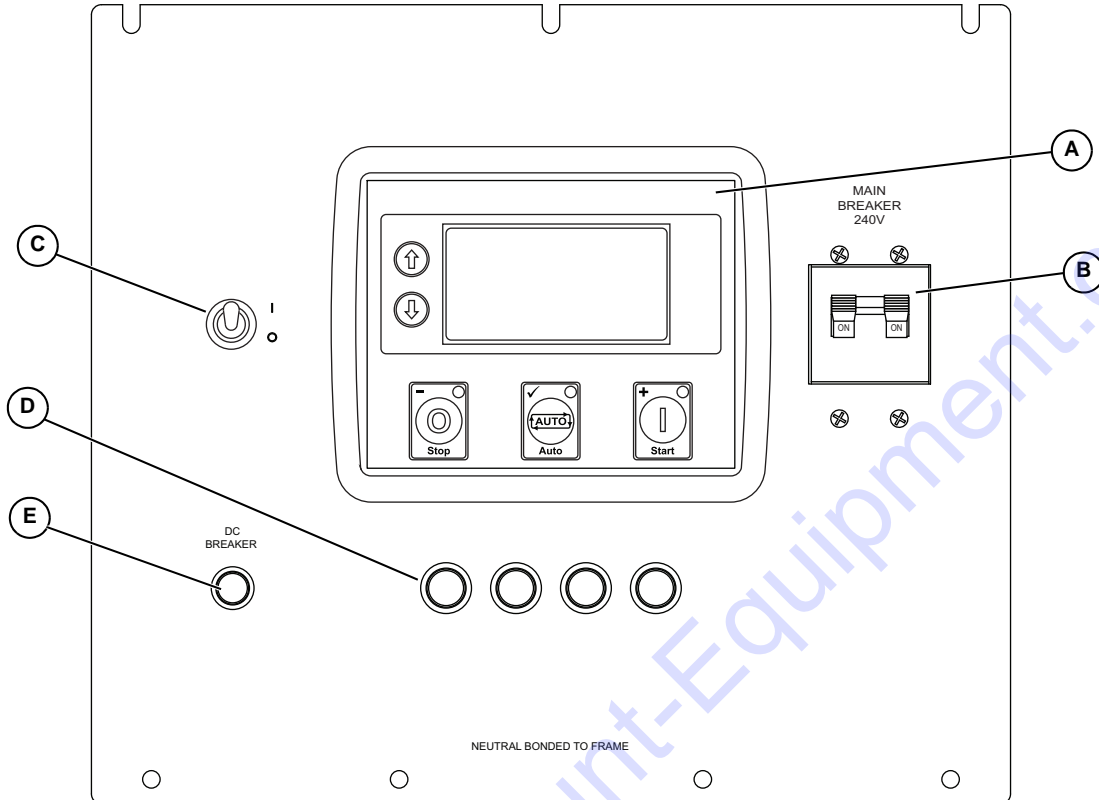

Figure 2-4. Control Panel

- | | | | |
|---|----------------------|---|-----------------------|
| A | Power Zone–DLA | D | AC/Light Breakers (4) |
| B | Main Circuit Breaker | E | DC Breaker |
| C | Control Power Switch | | |

Power Zone–DLA

The Power Zone–DLA is an auto start controller that monitors the unit and indicates operational status and fault conditions. The controller can be programmed to automatically start or stop based on time schedule, fault condition, or load demand.

The controller constantly monitors vital generator and engine functions for a number of preprogrammed alarm and fault conditions. When a fault condition occurs, the

engine will be shut down automatically and the LCD window will show the fault that caused the shutdown. To resume operation, the fault condition must be corrected.

This controller also records a history of unit performance, which may be viewed at any time and will not be lost when the controller is powered down.

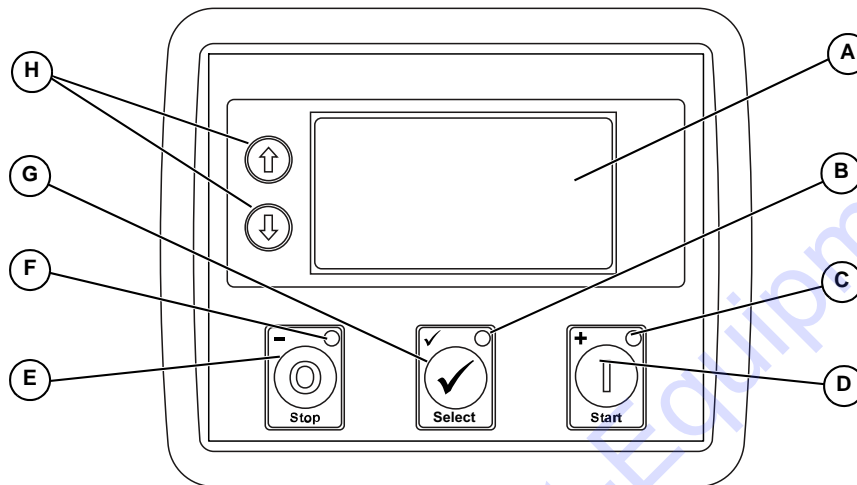

Figure 2-5. Power Zone–DLA Layout

Controller Features and Functions

(A) The Liquid Crystal Display (LCD) Window

This window displays the various operating screens. By viewing these screens, the operator can monitor both the engine and generator status while the unit is running.

(B) Select LED

This LED illuminates when the unit is running in AUTO mode.

(C) Start LED

This LED illuminates when the unit is running in MANUAL mode.

(D) Start Button

This button starts the engine if there are no shutdown errors and the engine is in “ready to start” status.

(E) Stop Button

This button shuts down the unit and puts the controller into STOP mode, whether in MANUAL mode or AUTO mode.

NOTE: To prevent damage to the generator and connected equipment, remove all loads from the generator by opening all circuit breakers (turn to the OFF [O] position) before pressing the stop button.

(F) Stop LED

This LED illuminates when the unit is in STOP mode and flashes when an Electrical Trip and Shutdown Fault has occurred.

(G) Select Button

This button confirms entries chosen in the various edit menus and screens.

(H) Menu Navigation

These buttons (↑, ↓) are used to navigate through the various operator screens.

Operator Screens

See [Figure 2-6](#). The operator screens display the most relevant and critical information an operator will need to properly configure and use the unit. From these six screens, the operator can access information necessary to operate the unit under normal conditions..

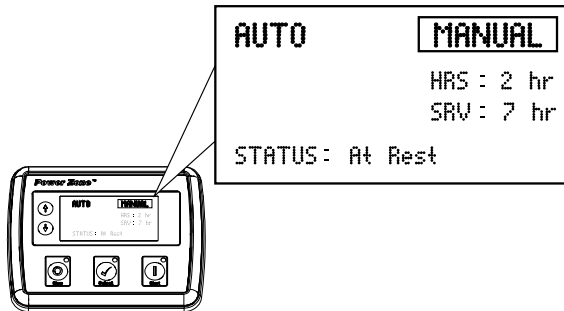

002354

Figure 2-6. Operator Screens Location

Home Screen

See [Figure 2-7](#). The Home screen is the default screen of the controller and displays after the controller is powered up and the unit management software is loaded. It displays the controller mode, total operating hours, hours left until the next service interval, engine operating status, and engine RPM. If the unit is in AUTO mode, the Home screen may also display whether or not the scheduler is enabled.

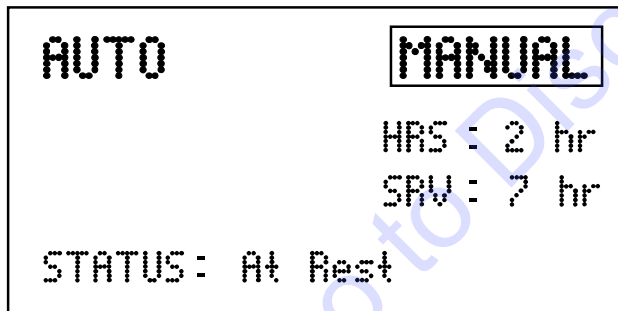

002544

Figure 2-7. Home Screen

Engine Screen

- See [Figure 2-8](#). The Engine screen displays battery voltage, oil pressure, coolant temperature and fuel level.

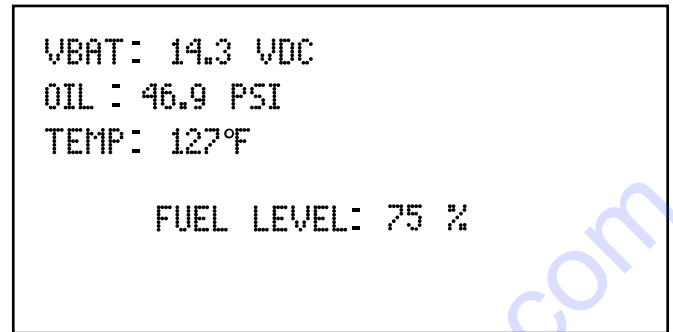

002355

Figure 2-8. Engine Screen

- VBAT: Displays the engine battery voltage. A normal reading is 12-14V on 12 volt systems and 24-26V on 24V systems (with the engine running).
- OIL: Displays engine oil pressure. Normal operating pressure is between 35-80 psi (241-552 kPa).
- TEMP: Displays engine coolant temperature. Normal operating temperature of the unit is between 100-230°F (38-110°C).
- FUEL LEVEL: Displays remaining fuel level as a percentage of usable fuel tank capacity.

Lights Screen

See [Figure 2-9](#). The Lights screen enables the operator to turn the lights on and off. Refer to [Light Operation](#) for more information.

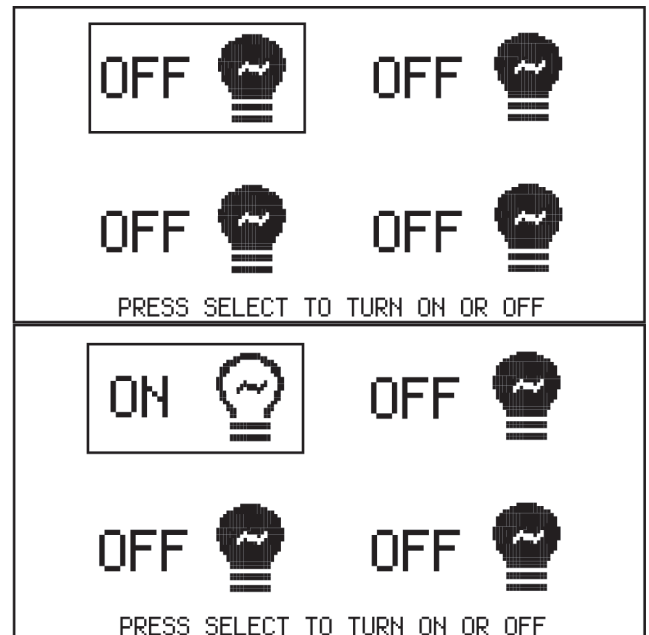

002327

Figure 2-9. Lights Screen

Scheduler Screen

See [Figure 2-10](#). The Scheduler screen enables the operator to program specific times for the lights to turn on and off. Once programmed, the Scheduler will start the engine and illuminate the lights until the designated shutdown time.

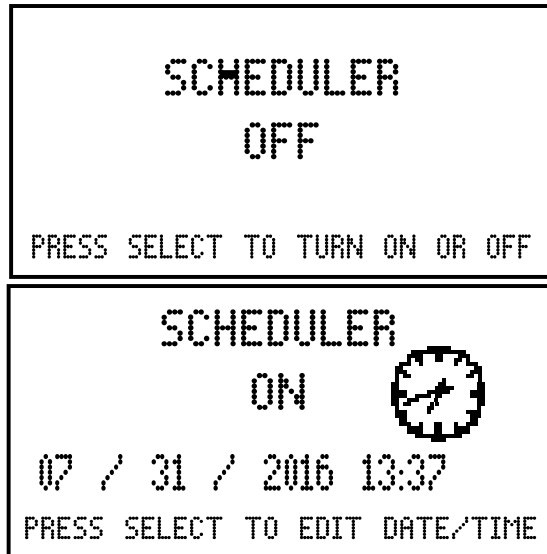

002329

Figure 2-10. Scheduler Screen

NOTE: This feature will only work in AUTO mode.

Maintenance Screens

See [Figure 2-11](#). The information displayed on the maintenance screens can be used to identify, diagnose and troubleshoot unit shutdown conditions and poor unit performance..



003779

Figure 2-11. Maintenance Screens

Icon	Description
	Home screen
	Alarms screen
	Maintenance screen
	Event log screen

Icon	Description
	About screen

To enter the navigation menu, use the following procedure:

1. Press both the ↑ and ↓ buttons simultaneously.
2. To select the required icon, press the ↑ button to cycle right and the ↓ button to cycle left until the desired operator screen section is reached.
3. Once the desired icon is at the top, press the Select (✓) button to enter that operator screen section.

NOTE: Every time the operator screens are entered, the home icon will be located at the top of the screen.

Alarms Screen

See [Figure 2-12](#). The Alarms (⚠) screen displays all the alarms, warnings, and engine Diagnostic Trouble Code (DTC) faults. When an alarm occurs, the controller automatically switches to this screen and remains there until the alarm is cleared. The Stop LED also flashes.

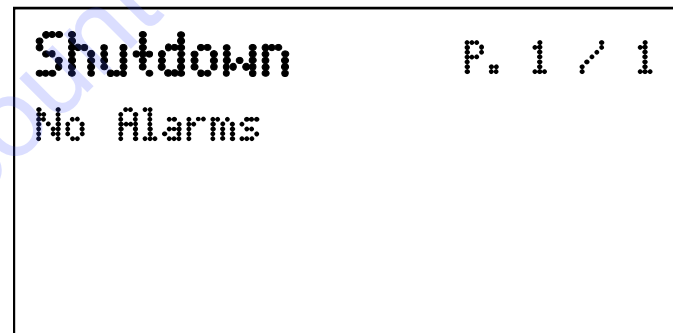

003780

Figure 2-12. Alarms Screen

- **Warnings** are non-critical alarm conditions and do not affect the operation of the generator system. They serve to draw the operator’s attention to an undesirable condition. By default, warning alarms are self-resetting when the fault condition is removed.
- **Electrical trips** stop the generator in a controlled manner. On initiation of the electrical trip condition, the controller de-energizes all the outputs, including the lights, to remove the load from the generator. Once this has occurred, the controller starts the cooling timer and allows the engine to cool off-load before shutting down the engine.
- **Shutdown alarms** stop the generator immediately. On initiation of the shutdown condition, the controller de-energizes all the outputs, including the lights, to remove the load from the generator.

Once this has occurred, the controller shuts the generator set down immediately to prevent further damage.

- **DTC faults** are displayed by the controller.

Table 2-1. Possible DTC Faults

Fault	DTC Description
Check Engine Fault	A fault not recognized by the controller has been detected. Contact the engine manufacturer for support.
Low Oil Pressure	Engine oil pressure has fallen below its configured low oil pressure alarm level.
Underspeed	Engine speed has fallen below its configured underspeed alarm level.
Overspeed	Engine speed has risen above its configured overspeed alarm level.
Low Fuel Level	Engine's fuel level has fallen below its configured low fuel level alarm.
Battery Under/Over Voltage	Engine's DC supply has fallen below or risen above its configured alarm level.

To view the active alarms, repeatedly press the ↑ and ↓ buttons until the LCD window displays the alarm.

Continue to press the ↑ and ↓ buttons to cycle through the alarms.

To exit the alarm screen, press the ↑ and ↓ buttons simultaneously to enter the navigation menu. Once entered, cycle to the desired operator screen.

NOTE: The alarm condition must be corrected before a reset will take place. If the alarm condition remains, it is not possible to reset the unit. The exception to this is the Low Oil Pressure alarm and similar 'active from safety on' alarms, as the oil pressure is low with the engine at rest.

To clear alarms that stop the generator, refer to [Resetting the Maintenance Alarms](#).

NOTE: The LCD backlight is on if the unit has sufficient voltage while the unit is turned on, unless the unit is cranking. In this case, the backlight is turned off.

If the controller is left in STOP mode for a period of inactivity, the controller enters POWER SAVE mode. To 'wake' the controller, press the Stop (O) button.

Maintenance Screen

See [Figure 2-13](#). The Maintenance screen (🔧) displays the maintenance alarms configured into the controller. The three alarms are for servicing the fuel filter, oil filter, and air filter.

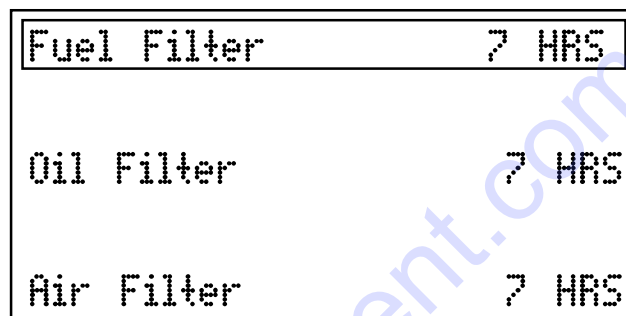

003781

Figure 2-13. Maintenance Screen

Event Log Screen

See [Figure 2-14](#). The controller's event log (📄) displays a list of the last 15 recorded electrical trips or shutdown events and the engine hours at which they occurred. Once the log is full, any subsequent electrical trip or shutdown alarm overwrites the oldest entry in the log. Therefore, the log always contains the most recent shutdown alarms.

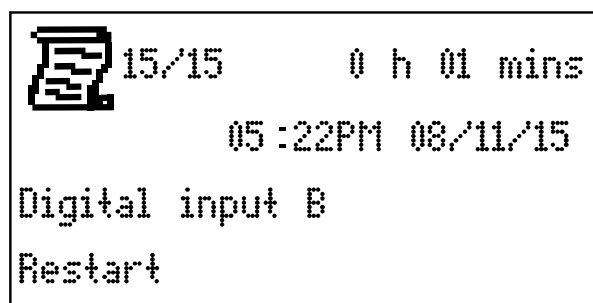

003782

Figure 2-14. Event Log Screen

To view the event log:

1. Press both ↑ and ↓ buttons simultaneously to display the navigation menu.
2. Cycle to the event log section and press the Auto button to enter.
3. Repeatedly press the ↑ or ↓ buttons until the LCD window displays the desired event.

Continuing to press down the ↑ or ↓ buttons will cycle through past alarms. Eventually the most recent alarm will display and the cycle begins again.

To exit the event log, press the ↑ and ↓ buttons simultaneously to enter the navigation menu. Once entered, cycle to the desired operator screen.

About Screen

See [Figure 2-15](#). The About () screen contains information about the controller such as the controller's date and time, the product and USB identification number, and the application and engine version.

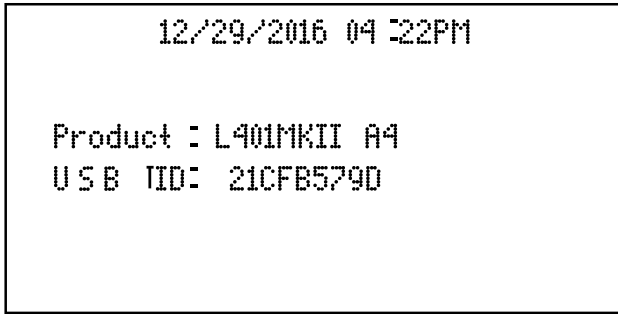

003783

Figure 2-15. About Screen

To order go to Discount-Equipment.com

Section 3: Operation

Light Tower Setup

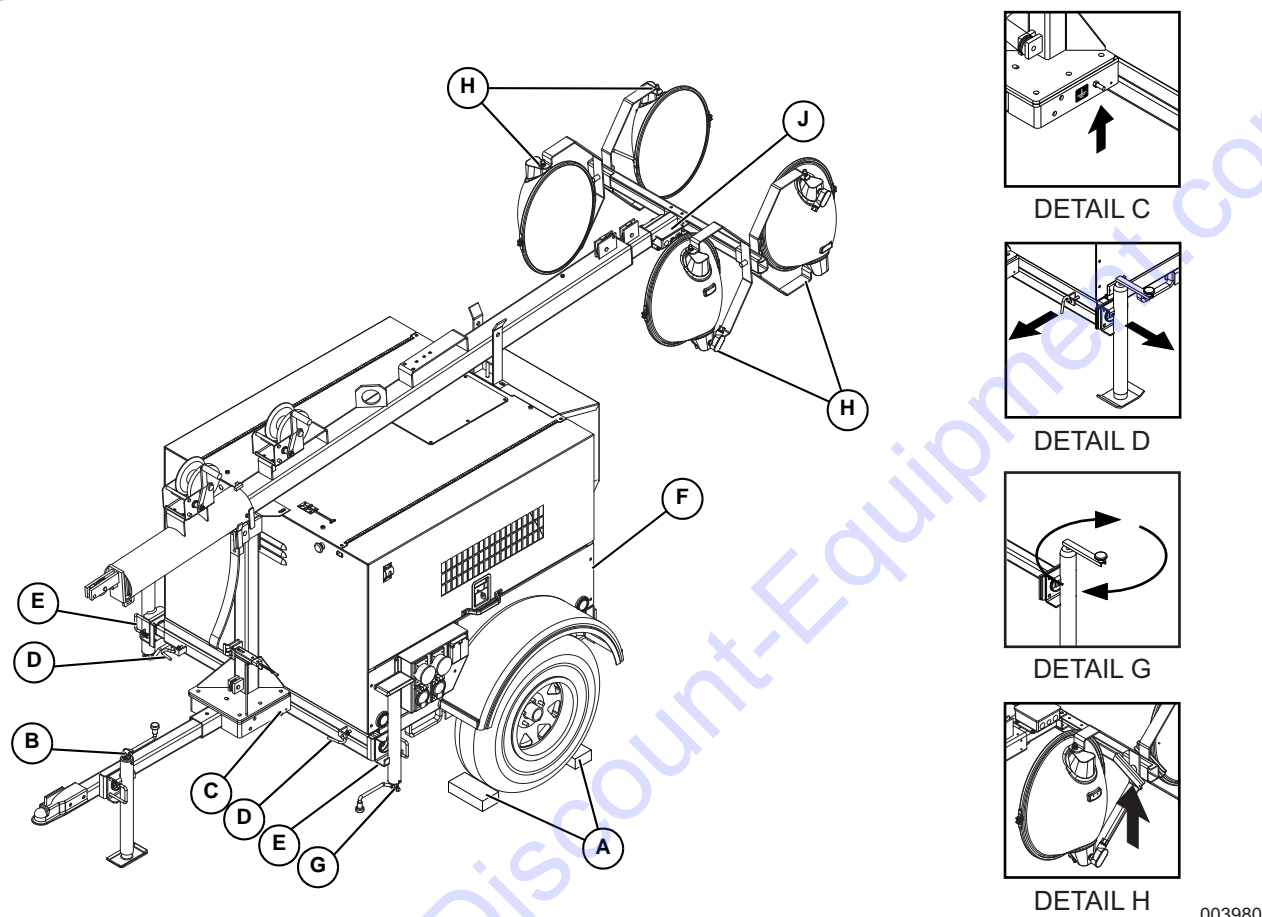

Figure 3-1. Set Up Outriggers and Jacks

003980



⚠ DANGER

High Voltage. Verify area above unit is clear of overhead wires and obstructions. Contact with high-voltage power lines will result in death or serious injury.

(000260a)

1. For maximum light coverage, position the unit at ground level or in a spot higher than the area being illuminated by the lamps.

NOTE: The mast extends up to 30 ft (9.14 m).

2. See **Figure 3-1**. Place the unit on firm ground that is relatively flat, and then block the wheels (A) to keep it from moving. This will make it easier to level the unit.
3. Pull the locking pin (B) on the tongue jack and rotate the jack 90°. Reinstall the locking pin. Turn the jack handle clockwise to raise the trailer tongue off of the towing vehicle.
4. A grounding stud (C) is located on the control box. For grounding requirements, follow the National Electrical Code (NEC), state, and local regulations.
5. Pull the locking pin (D) on the outrigger (E) and pull each outrigger out until the spring loaded locking pin snaps back into place. Pull the locking pin on the outrigger jack and rotate each jack 90° so the jack pad is facing down. Reinstall the locking pin.
6. Pull the locking pin on the rear jack (F) and rotate the jack 90°. Reinstall the locking pin. Rotate the jack handle clockwise to start leveling the trailer (see Detail G). Adjust all four jacks by rotating their handles (G) clockwise until they are firmly in contact with the ground and the trailer is as level as possible.
7. See Detail H. Before raising the mast, it may be necessary to adjust the lamps. The lamps may be adjusted up, down, left or right by simply aiming them in the desired direction.

Prestart Checklist

Before starting the unit, all items in the prestart checklist must be completed. This checklist applies to both manual and remote starting of the unit.



WARNING

Consult Manual. Read and understand manual completely before using product. Failure to completely understand manual and product could result in death or serious injury. (000100a)

- Verify all maintenance procedures are up to date. For more information, refer to **General Maintenance** and **Table 4-1**.
- The unit must be level.
- The unit must be dry. Look for water inside or near the unit; dry if needed.
- For grounding requirements, follow the National Electrical Code (NEC), state, and local regulations.
- Verify the Control Power switch is OFF (O).
- Verify all circuit breakers are OFF (O).
- Inspect all electrical cords; repair or replace any that are cut, worn, or bare.
- Verify all winch cables are in good condition and centered on each pulley. Do not use if cables are kinked or beginning to unravel.
- Check oil, coolant, and fuel levels. For more information, refer to **General Maintenance**.
- Verify battery connections are secure.
- Turn the battery disconnect switch ON, if equipped.
- Check the engine fan belt tension and condition.
- Check the engine fan belt guard.
- Check the engine exhaust system for loose or rusted components.
- Verify all covers are in place and secure.

Raising the Mast

1. Set up and level the unit. See **Light Tower Setup**.

WARNING

Tipping hazard. Extend the outriggers and level the unit before raising the mast. Keep the outriggers extended while the mast is up. Failure to do so could cause the unit to tip and fall and could result in death or serious injury. (000266)



DANGER

Electrocution. DO NOT use the unit if electrical cord is cut or worn through. Doing so will result in death or serious injury. (000263a)

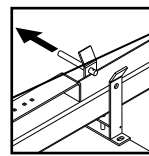

DETAIL A

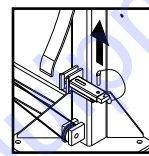

DETAIL C

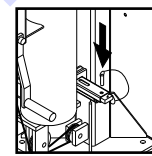

DETAIL E

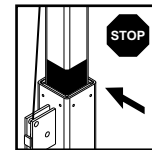

DETAIL G

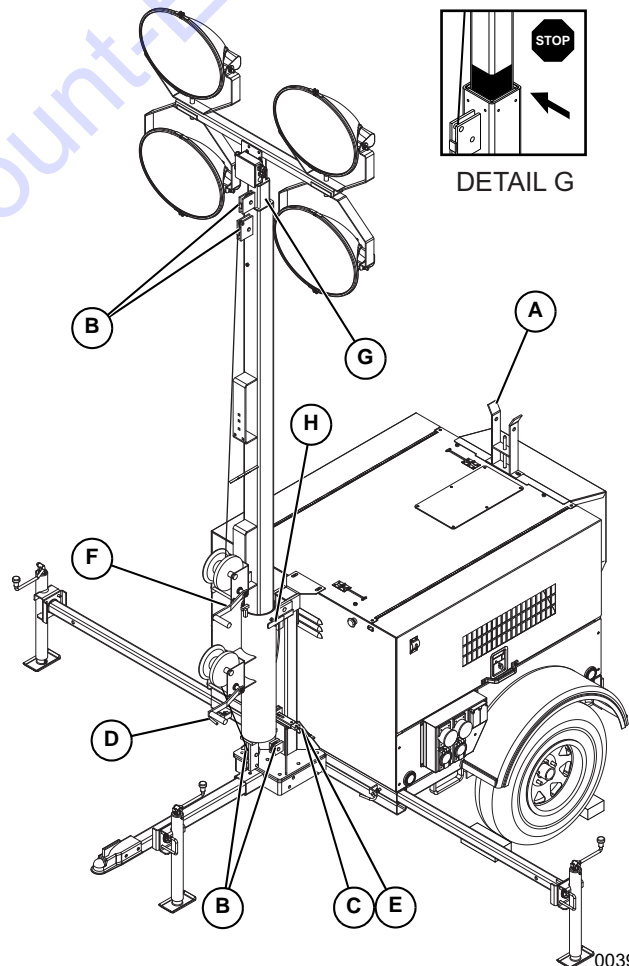

Figure 3-2. Pulley Locations

2. See [Figure 3-2](#). Remove mast cradle locking pin from mast cradle (A).
3. Check the mast cables for excessive wear or damage. Verify the cables are properly centered in each pulley (B). Check the electrical cord for damage.
4. Remove the safety pin from the mast lock bar (C). Using the handle for the lower mast winch (D), raise the mast until it is vertical and the tab on the mast is positioned into the mast lock. The mast lock bar should snap into place automatically. Secure the lock with the safety pin (E).
5. Use the winch (F) to slowly extend the mast, making sure that the coiled electrical cord is extending at the top sections of the mast. STOP extending the mast when the colored mark (G) on the second mast section is visible as seen in Detail G.
6. The mast can be rotated by loosening the locking knob at the bottom of the mast (H). Turn the mast until the lights face in the desired direction and then tighten the mast rotation knob to secure the mast in position.

WARNING

Tipping hazard. Do not extend the mast beyond the colored mark on the second mast section. The unit can become unstable and tip or fall, causing injury.

(000262)

WARNING

Personal Injury. Stop immediately if the mast hangs up or the winch cable develops slack. Excess slack could cause the mast to collapse, resulting in personal injury or equipment damage.

(000265)

IMPORTANT NOTE: Contact a Generac Mobile Products Authorized Service Dealer immediately if the mast hangs up or the winch cable develops slack.

Preparing for Start-Up

NOTE: If the engine was run out of fuel or the fuel tank was drained, it may be necessary to bleed the fuel lines before starting. Refer to the engine manual supplied with the unit.

Select AUTO or MANUAL Mode

See [Figure 3-3](#). Using the arrows on the Power Zone-DLA, select either AUTO or MANUAL on the Home screen.

- AUTO mode is required for programming automatic start and stop times (see [Scheduler Screen](#)), or enabling the “Night Watchman” sensor (see [Scheduler Screen](#).)
- MANUAL mode is used for on-demand control of the lights and convenience outlets.

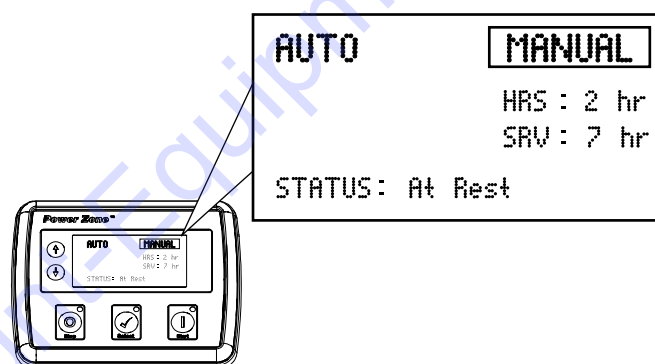

002354

Figure 3-3. Selecting MANUAL or AUTO Mode

Configure for Intended Use

As described in “General Information”, the engine in this unit runs at low speed when the LED lights are operating and no loads are connected to the 120 or 240V convenience outlets. The engine runs at high speed when the LED lights are turned off. Therefore, before starting, determine if auxiliary equipment will be connected to the convenience outlets. Then set up the unit based on the intended use:

LED Lights Only

Turn the 240V outlet breaker OFF. The engine will run at low speed while operating, greatly reducing sound emissions and fuel consumption.

LED Lights and Export Power

Turn the 240V outlet breaker ON and Load Sense OFF. The engine will run at high speed for powering high amperage equipment.

LED Lights and Export Power with Load Sense

Turn the 240V outlet breaker ON and Load Sense ON. The engine will run at high speed when detecting applied load(s) such as hand tools and low amperage equipment.

TO PURCHASE THIS PRODUCT PLEASE CONTACT US



**Equipment Financing and
Extended Warranties Available**



**Discount-Equipment.com is your online resource for
commercial and industrial quality parts and equipment sales.**

561-964-4949

visit us on line @ www.discount-equipment.com

Select an option below to find your Equipment

Search by Manufacturer

Search by Product Type

Request a Quote

We sell worldwide for the brands: Genie, Terex, JLG, MultiQuip, Mikasa, Essick, Whiteman, Mayco, Toro Stone, Diamond Products, Generac Magnum, Airman, Haulotte, Barreto, Power Blanket, Nifty Lift, Atlas Copco, Chicago Pneumatic, Allmand, Miller Curber, Skyjack, Lull, Skytrak, Tsurumi, Husquvarna Target, Stow, Wacker, Sakai, Mi-T-M, Sullair, Basic, Dynapac, MBW, Weber, Bartell, Bennar Newman, Haulotte, Ditch Runner, Menegotti, Morrison, Contec, Buddy, Crown, Edco, Wyco, Bomag, Laymor, EZ Trench, Bil-Jax, F.S. Curtis, Gehl Pavers, Heli, Honda, ICS/PowerGrit, IHI, Partner, Imer, Clipper, MMD, Koshin, Rice, CH&E, General Equipment, Amida, Coleman, NAC, Gradall, Square Shooter, Kent, Stanley, Tamco, Toku, Hatz, Kohler, Robin, Wisconsin, Northrock, Oztec, Toker TK, Rol-Air, APT, Wylie, Ingersoll Rand / Doosan, Innovatech, Con X, Ammann, Mecalac, Makinex, Smith Surface Prep, Small Line, Wanco, Yanmar

Table 3-1 illustrates the four possible combinations of 240V outlet breaker and Load Sense switch positions.

Table 3-1. Engine Speed Selection

		Load Sense Switch	
		ON	OFF
240VAC Outlet Breaker	ON	Load dependent—variable speed*	High speed
	OFF	Low speed	Low speed
*Engine will speed up automatically when more power is drawn from receptacles.			

Emergency Stop Switch

The unit is equipped with one emergency stop switch. For location of the emergency stop switch, refer to **Component Locations**. The red switch is clearly labeled EMERGENCY STOP. The switch can be accessed and activated with all doors closed and locked.

Activate the emergency stop switch by pushing the red button in until it locks down. This will trip the main circuit breaker which will open the contact, disconnecting the load to the connection lugs. This will also open the fuel circuit, shutting down the engine.

The switch will remain closed until it is pulled out.

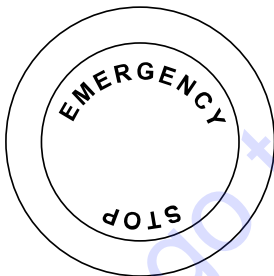

002393

Figure 3-4. Emergency Stop Switch

NOTE: Use the emergency stop switch only when the unit must be shut down immediately. For any other shut down, refer to **Shutting Down the Unit**.

Engine Break-In Requirements

NOTE: The EPA final tier 4 Isuzu engines have an engine break-in duration that will prohibit the unit from providing rated standby power upon factory delivery. The unit is tested at the factory and is initially capable of a prime standby power output. The engine performance will increase to 95% of full rated power during the first 20 hours of loaded operation. The unit will provide full rated

power after the complete engine break-in period of 70 hours of loaded operation.

Operate the engine at heavy loads (60-90% [24-36kW] of rated output maximum) as much as possible during the break-in period. If the engine has spent significant time at idle, constant speed(s) and/or light load or if makeup oil is required, a longer break-in period may be needed. Refer to the engines operator’s manual for a full description of necessary procedures on the addition of oil and extension of the break-in period. For more information on regular maintenance intervals, refer to **Basic Maintenance Guide**.

Manually Starting the Unit

STOP mode is the default start-up setting for all units equipped with the Power Zone—DLA. Use the following procedure to start the generator in MANUAL mode.

1. Verify the 240VAC outlet breaker is switched OFF (O).
2. Switch the main circuit breaker ON (I).
3. When the controller powers up, the Home screen displays on the LCD screen and the Stop LED illuminates to indicate that the controller is in STOP mode. Press the Start button to initiate the startup procedure. Assuming there are no existing engine faults, the engine will start and the Start LED will illuminate.

NOTE: The engine can be started from any screen. It may take a few seconds for the engine to run smoothly and reach its governed operating speed.

4. If the engine does not start after the first cranking attempt, the engine will pause for 15 seconds to allow the starter to cool. The controller backlight will go out. The engine will make two more attempts to start for a total of three crank cycles.
5. If the engine does not start and run within three starting cycles, the LCD screen will display the “Fail to Start” alarm. The starting sequence can be repeated after the starter cools for at least two minutes. Pressing the Stop (O) button will clear the alarm and reset the controller.

Auto (Remote) Starting of the Unit

Auto mode is used when the unit is started from a location other than the control panel by using a transfer switch. Auto (remote start) is the normal setting when the generator is being used as a standby power supply. Before putting the unit in the Auto mode, review the **Prestart Checklist** and **Manually Starting the Unit**. Also following any warnings and information on isolating

the generator with a transfer switch if the unit is to be used as a standby power supply. Then continue with the steps described below:

1. Perform a manual start of the unit at least once to verify that the engine is operating correctly.

NOTE: The lights are automatically disconnected on startup. The main circuit breaker can be left on if no other loads are connected, except for the lights. Any connected external loads must be disconnected by a transfer switch when starting the unit.

2. If a check of the remove start circuit is desired:
 - a. Remove the wires from the remote start terminal block. Press the Auto button. The Auto LED will be lit.
 - b. Attach a jumper wire (minimum 16 gauge) across the two terminals on the remote start terminal block. This applies a ground to the controller to close the starting circuit contacts. The engine should crank, start and run.
 - c. Remove the jumper wire from the remote start terminal block and the engine will stop.
 - d. Reconnect any necessary wires from the remote start switch (transfer switch) to the remote start terminal block.
3. Confirm the unit is in Auto mode. The Auto LED should be lit.
4. Secure the unit by closing and locking all access doors.
5. The unit is now ready for remote starting

Light Operation



WARNING

Burn hazard. Never operate lights with a damaged or missing lens cover. Lamps are hot and pressurized while in use. Unprotected lamps can shatter, causing severe injury.

(000277)



WARNING

Burn hazard. Lamps become extremely hot while in use. Allow 10–15 minutes for cooling before handling or lowering mast. Touching a hot lens or fixture can cause severe burns.

(000278)

See [Figure 3-5](#). The lights are turned on and off using the Power Zone–DLA. To view the light screen, press the ↑ button three times from the Home screen.

NOTE: The lights can only be turned ON and OFF while the unit is running in MANUAL mode. They operate automatically in AUTO mode.

1. Once the engine is up to temperature and running smoothly, switch the main circuit breaker ON (I).

2. To turn the light(s) ON, press the Select (✓) button. To turn the light(s) OFF, press the Select (✓) button.

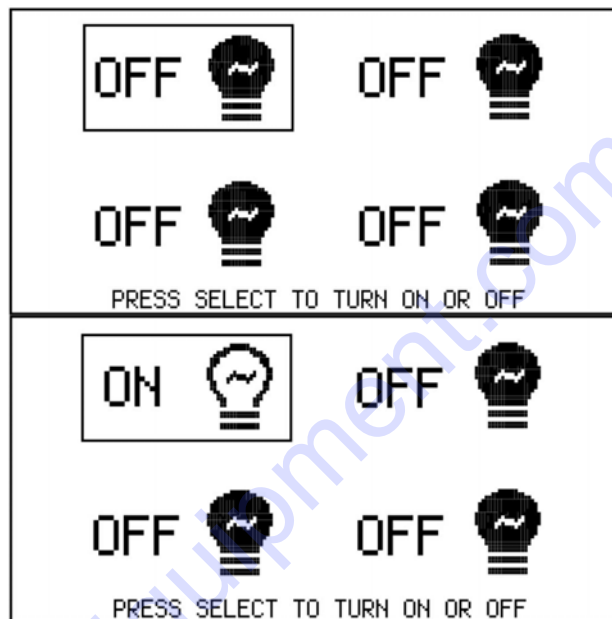

002327

Figure 3-5. Lights Screen

NOTE: The lights require a warm up period of 5-15 minutes before they reach full output. If the lights are shut down, they require a cool down period of approximately 10 minutes before they can be switched on again.

NOTE: The light tower uses four 1000W or 1050W bulbs. When checking or replacing the bulbs, wipe them with a clean cloth to avoid leaving any grease, oil residue, or fingerprints on the glass. Any residue can create a hot spot on the bulb, causing premature bulb failure.

Engine Derating

All units are subject to derating for altitude and temperature. Derating reduces the available power for operating tools and accessories connected to the receptacles. Typical reductions in performance are 2-4% for every 1000 ft (305 m) of elevation and 1% per 10°F (5.6°C) increase in ambient air temperature over 72°F (22°C).

Wet Stacking

The unit is powered by a diesel engine. Diesel engines are subject to “wet stacking” if lightly loaded. Wet stacking occurs when an engine is run at less than 30% of its full load capacity, causing unburned fuel to accumulate in the exhaust system. Wet stacking can be detected by continuous black exhaust when the unit is under a constant load. It can also cause fouling of injectors and buildup on engine valves. Diesel engines

operate properly when applied loads are between 30% and 100% capacity. Appropriate generator sizing is determined by the anticipated load.

If the unit is in a wet stack condition, load the unit heavily for five hours or until the exhaust is clear.

Voltage Regulation

Units are equipped with an electronic voltage regulator. The voltage regulator controls the output of the generator by regulating the current into the exciter field. The regulator has three screwdriver adjustable potentiometers that may be adjusted for voltage, stability and voltage roll-off (U/F). The voltage regulator is adjusted before shipment from the factory. Contact Generac Mobile Products LLC for additional information before attempting to adjust the voltage regulator.

Customer Convenience Outlets

See **Figure 3-6**. The unit is equipped with six convenience outlets for powering accessories or tools from the generator. Power is supplied to the outlets any time the engine is running and the main circuit breaker is switched ON (I). Each outlet has an individual circuit breaker, located behind the outlet panel.

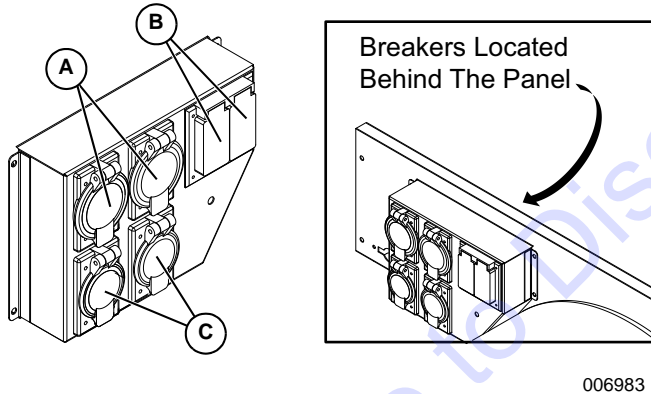

Figure 3-6. Location of Outlets

A	240V/30A Twist-lock
B	120V/20A GFCI
C	240V/50A Twist-lock

See **Figure 3-6**. The circuit breakers are labeled with the corresponding voltage for the receptacle they protect.

With all of the lights OFF, full generator power output is available to the receptacles.

NOTE: All equipment or load panels connected to the generator **MUST** be properly grounded. If these appliances do not have grounded plugs, a ground wire **MUST** be added between the equipment and the grounding stud on the receptacle panel per the National Electrical Code (NEC), state, and local regulations.

Remote Start Terminal Block

See **Figure 3-7**. The remote start terminal block (A) is located near the control panel and provides a connection for installation of a remote start switch which will allow the unit to be started by a remote dry-contact closure switch.

Before entering AUTO mode, verify that the contacts on any remote switch linked to the unit are OPEN. If the contacts on a remote switch are closed, the engine will crank and start when AUTO mode is entered. Attach the switch leads to the two unused terminals on the unit's remote start terminal block. For more information, refer to **Auto (Remote) Starting of the Unit**.

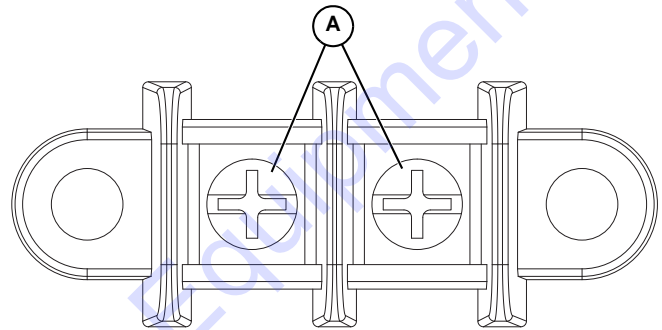

Figure 3-7. Remote Start Terminal Block

Transfer Switch

When the unit is used as a standby power supply, it must be equipped with a transfer switch which isolates it from the utility's distribution system. A transfer switch is designed to transfer electrical loads from the normal power source (utility) to the emergency power source (generator) when normal voltage falls below a prescribed level. The transfer switch automatically returns the load back to the normal source when power is restored back to operating levels.)



WARNING

Phase rotation must be compatible. Incompatible phase rotation could result in equipment damage, death or serious injury.

(000226a)

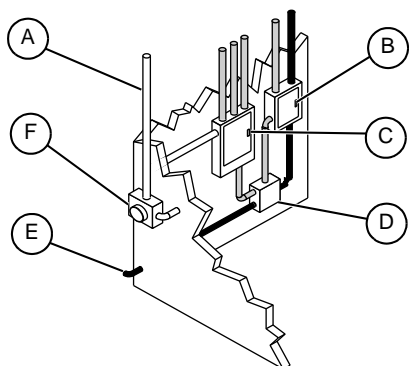

002807

Figure 3-8. Transfer Switch Operation

A	Incoming Utility Power
B	Emergency Distribution Panel (Generator Power)
C	Main Distribution Panel (Utility Power)
D	Transfer Switch
E	Power From Generator
F	Utility Meter
WHITE	Incoming Utility Power
GRAY	Normal Utility Power Circuit
BLACK	Emergency Generator Power Circuit



⚠ DANGER

Electrocution. Never connect this unit to the electrical system of any building unless a licensed electrician has installed an approved transfer switch. Failure to do so will result in death or serious injury. (000150)

Installation of a transfer switch or other type of remote starting device is the responsibility of the user. Installation of such devices must be performed by following all directions supplied by the manufacturer of the switch. If attaching the unit to a power supply normally serviced by a utility company, notify the utility company and check local and state regulations. Familiarize yourself with all instructions and warning labels supplied with the switch.

⚠ WARNING

Only a trained and licensed electrician should perform wiring and connections to unit. Failure to follow proper installation requirements could result in death, serious injury, and damage to equipment or property. (000155)

AUTO Exercise Timer

The controller is capable of starting and stopping the unit automatically, based on a programmable schedule. Units installed in a standby application should be exercised regularly to maintain operating condition and to ensure responsiveness in an emergency situation. Use the following procedures to operate the unit in AUTO mode:

NOTE: The controller must be in AUTO mode to run at the programmed time. Use a trickle or solar battery charger to prevent the controller from draining the battery while in AUTO mode.

1. Push both the STOP/RESET (O) and AUTO buttons simultaneously.
2. Push the ↑ button until the wrench icon is selected. Push the AUTO button to select it and enter the parameters.
3. Adjust the parameter number to enable the desired timer. When the correct parameter number is showing, press the AUTO button to enter it. Press the MANUAL/START (I) button to change it to 1 to enable the timer and press the AUTO button to save it.

NOTE: The ↑ and ↓ buttons will adjust the hundredths place of the parameter number and the MANUAL/START (I) and STOP/RESET (O) buttons will adjust the low digits. Up to eight events can be scheduled at a time.

4. Adjust the parameter number to adjust the time of the desired event and then press the AUTO button to enter it. Press the MANUAL/START (I) and STOP/RESET (O) buttons to change the time. Holding down either button will change the time faster. Press the AUTO button to save the time.
5. Adjust the parameter number to adjust the day of the week and press the AUTO button to enter it. Press the MANUAL/START (I) and STOP/RESET (O) button to change to the desired day and press the AUTO button to save it.

NOTE: Only one day can be chosen per event if parameter 903 is “1” (monthly).

6. Adjust the parameter number to adjust duration of the timer and press the AUTO button to enter it. Press the MANUAL/START (I) or STOP/RESET (O) buttons to change the duration and press the AUTO button to save it.

NOTE: If any of the scheduled time slots are currently active, the controller will begin the starting sequence and start the unit provided there are no shutdown conditions present.

The times for the scheduled timers and events are based on the internal clock for the controller. Use the corresponding parameters to adjust to the correct time of the day and correct date.

This table lists the parameters needed to schedule an event and to adjust the clock within the controller.

NOTE: If parameter 902 is "0", then the auto exercise timer is enabled and if it is "1", then the autolight timer is enabled.

Parameter	Description	Details
Configuration Parameters - Scheduler		
901	Enable Scheduler	On (1), Off (0)
902	Schedule Run On or Off	Load On (1), Off (0)
903	Schedule Period	Weekly (0), Monthly (1)
904	Scheduler (1) Start Time	0:00:00
905	Scheduler (1) Start Day	0 (1=Monday)
906	Scheduler (1) Start Week	1,2,3,4
907	Scheduler (1) Duration	0:00:00
908	Scheduler (2) Start Time	0:00:00
909	Scheduler (2) Start Day	0 (1=Monday)
910	Scheduler (2) Start Week	1,2,3,4
911	Scheduler (2) Duration	0:00:00
912	Scheduler (3) Start Time	0:00:00
913	Scheduler (3) Start Day	0 (1=Monday)
914	Scheduler (3) Start Week	1,2,3,4
915	Scheduler (3) Duration	0:00:00
916	Scheduler (4) Start Time	0:00:00
917	Scheduler (4) Start Day	0 (1=Monday)
918	Scheduler (4) Start Week	1,2,3,4
919	Scheduler (4) Duration	0:00:00
920	Scheduler (5) Start Time	0:00:00
921	Scheduler (5) Start Day	0 (1=Monday)
922	Scheduler (5) Start Week	1,2,3,4
923	Scheduler (5) Duration	0:00:00
924	Scheduler (6) Start Time	0:00:00
925	Scheduler (6) Start Day	0 (1=Monday)
926	Scheduler (6) Start Week	1,2,3,4
927	Scheduler (6) Duration	0:00:00
928	Scheduler (7) Start Time	0:00:00
929	Scheduler (7) Start Day	0 (1=Monday)
930	Scheduler (7) Start Week	1,2,3,4
931	Scheduler (7) Duration	0:00:00
932	Scheduler (8) Start Time	0:00:00

Parameter	Description	Details
933	Scheduler (8) Start Day	0 (1=Monday)
934	Scheduler (8) Start Week	1,2,3,4
935	Scheduler (8) Duration	0:00:00
Configuration Parameters - Time and Date		
1001	Time of Day	0:00:00
1002	Day of Month	1-31
1003	Month of Year	1-12
1004	Year	0-99

Shutting Down the Unit

Check with personnel using power supplied by the unit and let them know the power is going to be turned off. Verify the power shutdown will not create any hazards by accidentally turning off equipment that needs to remain running (pumps, compressors, lights, etc.).

1. Remove all loads from the outlets.
2. Turn the lights OFF using the controller.
3. Switch the outlet breaker OFF (O).
4. Press the Stop (O) button.
5. After the unit shuts down, switch the Control Power switch breaker OFF (O).

NOTE: Disconnect the battery if the unit is to be stored for an extended period. Refer to the engine operator's manual for additional extended storage procedures.

Automatic Shutdown

This unit is equipped with a low oil pressure and high coolant temperature automatic shutdown system. This system will automatically shut off the fuel supply to stop the engine if oil pressure drops too low or the engine exceeds normal operating temperature. Return the Control Power switch to the STOP position to reset the unit after the cause of shutdown has been determined.

NOTE: The unit will turn off the lights at the stop time, but the engine will continue to run for up to five minutes as a cool down. If the stop button is pressed, the unit will immediately stop.

Lower Radiator Hose Heater (If Equipped)

Use and Maintenance

The lower radiator hose heater is designed to prevent engine coolant from freezing in extreme cold weather conditions. While the heater is designed to be operated

overnight if necessary, two to five hours of heating just prior to starting is usually sufficient for proper engine starting.

NOTE: Use the lower radiator hose heater only in its designated location. Improper use can damage the engine.

Perform the following steps when operating a unit equipped with a lower radiator hose heater.

1. Verify the unit is level so as to maintain proper orientation of the heater while it is in operation.
2. Verify the cooling system is full of the proper mixture of water and engine coolant before each heater use.
3. Use only an undamaged, outdoor rated, three-prong grounded 120VAC extension cord with a minimum amperage rating of 10A. Connect the cord to a properly grounded 120VAC, GFCI outlet.
4. Before starting the engine, unplug the extension cord from the power first, then unplug the heater cord set from the extension cord.

Lowering the Mast

1. Shut down the lights and engine. See [Shutting Down the Unit](#). Allow the lights to cool 10-15 minutes before lowering the mast.
2. Loosen the mast rotation knob. Rotate the mast until the white arrows are aligned and the metal stop tabs are touching. Tighten the mast rotation knob.
3. Turn the upper mast winch handle counterclockwise to collapse the mast to its lowest position. verify the electrical cord does not get caught in, or pinched by, the mast while it is being lowered.

WARNING

Personal Injury. Stop immediately if the mast hangs up or the winch cable develops slack. Excess slack could cause the mast to collapse, resulting in personal injury or equipment damage. (000265)

IMPORTANT NOTE: Contact an Generac Mobile Products Authorized Service Dealer immediately if the mast hangs up or the winch cable develops slack.

4. Release the mast lock by pulling the safety pin on the mast lock and pulling the lock bar free. Turn the handle of the lower mast winch counterclockwise until the mast rests in the transport cradle.

NOTE: If the mast lock bar does not pull free, activate the lower winch slightly to relieve pressure on the mast bar.

5. After the mast is completely down, insert the mast cradle locking pin and secure it with the safety pin.
6. If the unit is going to be moved, remove the lights from the mast and stow for transportation. See [Removing the Lights for Transportation](#).

Removing the Lights for Transportation

1. See [Figure 3-9](#). On units equipped with quick disconnect fittings for the lights, disconnect the power cords from the junction box at the top of the mast.
2. Replace the dust caps on the junction box. On other units, remove the junction box cover on the top of the mast and disconnect **ONLY** the mast light wires from the terminal blocks.
3. To release the wires from the terminal blocks, flip the locking levers down and pull out the appropriate wires.
4. Remove the lights by removing the wing nut that holds the light fixture bracket to the cross tube.
5. Attach the lights to the storage brackets (if equipped) located on the mast tube on either side of the central lifting eye.

NOTE: When installing the lights, verify the star washer is in place between the trunnion and T-handle before tightening.

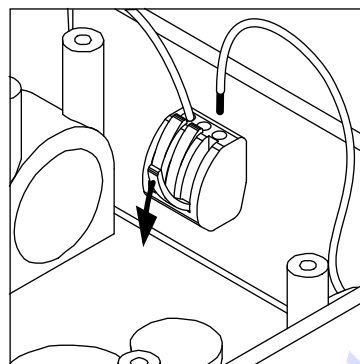

004481

Figure 3-9. Removing Lights

Towing the Unit

Once the engine is shut down and the mast and lights are properly stowed, follow these steps to prepare the unit for towing.

1. Raise the rear jack completely and release the locking pin to rotate it up into the travel position. Verify the locking pin snaps into place.
2. Raise the outrigger jacks completely and release the locking pins to rotate them up into the travel position. Verify the locking pins snap into place. Release the outrigger locking pins and slide the outriggers into the trailer frame until the locking pins snap into place.
3. Use the tongue jack to raise or lower the trailer onto the hitch of the towing vehicle. Lock the hitch coupling and attach the safety chains or cables to the vehicle. Remove the tongue jack locking pin and rotate the jack into the travel position. Replace the locking pin.

NOTE: A film of grease on the coupler will extend coupler life and eliminate squeaking. Wipe the coupler clean and apply fresh grease each time the unit is towed.

4. To ensure proper operation of the jacks, lubricate the grease fittings located on the leveling jacks. Refer to [Jack Maintenance](#). For maintenance interval information, refer to [Table 4-1](#).
5. Connect any trailer wiring to the tow vehicle. Check for proper operation of the directional and brake lights.
6. Verify the cradle locking pin is in place.
7. Verify the enclosure and doors are properly latched.
8. If the unit is going to be driven over rough ground, remove the bulbs from the light fixtures.
9. Check for proper inflation of the trailer tires. For maximum tire pressures, refer to [Specifications](#).
10. See [Figure 3-10](#). Check the wheel lugs. Tighten or replace any lugs that are loose or missing. If a tire has been removed for axle service or replaced,

tighten the lugs, in the order shown, to the following specifications:

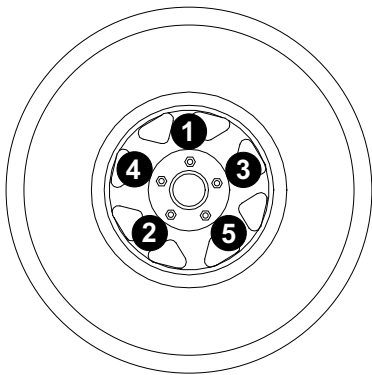

003754

Figure 3-10. Tightening Wheel Lugs

- Start all lug nuts by hand.
- First pass: tighten to 20-25 ft-lbs (27-33 Nm).
- Second pass: tighten to 50-60 ft-lbs (67-81 Nm).
- Third pass: tighten to 90-120 ft-lbs (122-162 Nm).

NOTE: After the first road use, re-torque the lug nuts in sequence.

- Maximum recommended speed for highway towing is 45 mph (72 km/h). Recommended off-road towing speed is not to exceed 10 mph (16 km/h) or less, depending on the terrain.

Lifting the Unit

Follow these steps to prepare the unit for lifting:

- Verify the equipment being used to lift the unit is in good condition and has sufficient capacity. For approximate weights, refer to **Specifications**.
- Verify the cradle locking pin is in place.
- Close and lock all hoods and doors.
- See **Figure 3-11**. Stow the mast and lights in the travel position as shown.
- Always remain aware of people and objects around the unit while preparing, maneuvering, and lifting the unit.
 - When lifting the unit, attach any slings, chains or hooks directly to the central lift point (A).
 - Use the forklift pockets (B) with care. Lift only from the side. Avoid approaching the unit at an angle, as this can permanently damage the forklift pockets, tires, or cabinet. Verify the forklift tines are clear of any obstructions before lifting.

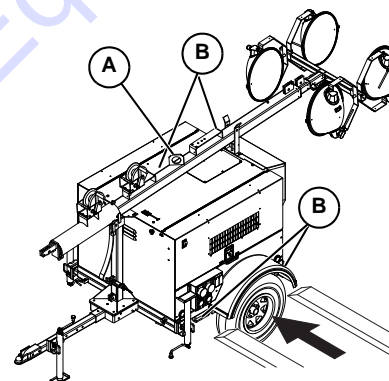

003985

Figure 3-11. Lift Points

This page intentionally left blank.

To order go to Discount-Equipment.com

Section 4: Maintenance

Emissions Information

For warranty information, please refer to the diesel engine manual supplied with this unit.

Daily Walk-Around Inspection

Perform a walk-around inspection of the unit every day before starting the unit. Look for conditions that could hinder performance or safety, such as (but not limited to):

- Oil, coolant and fuel leakage
- Blocked vents
- Loose or missing hardware
- Loose or broken electrical connections.

Inspect the fan belt for cracks, fraying, or stretching. Verify the belt is properly seated in the pulley grooves. Replace the belt according to the manufacturer's recommendations.



Equipment Damage. Failure to perform a daily inspection could result in damage to the unit.

(000306)

General Maintenance

Poorly maintained equipment can become a safety hazard. In order for the equipment to operate safely and properly over a long period of time, periodic maintenance and occasional repairs are necessary. **DO NOT** perform routine service (oil and filter changes, cleaning, etc.) unless all electrical components are shut off.

Regular maintenance will improve performance and extend engine/equipment life. Generac Mobile Products LLC recommends that all maintenance work be performed by a Generac Mobile Products Authorized Service Dealer. Regular maintenance, replacement or repair of the emissions control devices and systems may be performed by any repair shop or person of the owner's choosing. However, to obtain emissions control warranty service free of charge, the work must be performed by a Generac Mobile Products Authorized Service Dealer or authorized Mitsubishi engine dealer depending on the repair. See the emissions warranty.

Preparing for Service

Before servicing the unit, always follow the instructions listed below.

1. If unit is equipped with the Power Zone controller, verify the Control Power switch is OFF. Otherwise, verify the key switch is in the OFF position.

2. Verify the circuit breakers are OFF.
3. Disconnect the negative (-) terminal on the battery.
4. Activate (push in) the emergency stop switch.
5. Attach a "Do Not Start" sign to the control panel. This will notify everyone that the unit is being serviced and will reduce the chance of someone inadvertently trying to start the unit.

Cleaning the Unit

Always clean the Light Tower after each use to remove dust, grease, mud, or spilled fuel or oil. Use soft, clean rags to wipe the cabinet exterior and control panel. Low-pressure compressed air (less than 40 PSI [276 kPa]) can also be used to remove dust and debris from the cabinet interior.

This unit contains sensitive electronic components that can be damaged by high pressure and heat. Therefore:

- Do not wash the unit with a high pressure hose or power washer.
- Do not wash the engine block or fuel tank with a power washer or steam cleaner. Water may enter the cabinet and collect in the generator windings or other electrical parts, causing damage.

Inspecting the Unit

- If the unit is stored outside, check for water inside the cabinet and generator before each use. If wet, dry the unit thoroughly before starting.
- Inspect condition of electrical cords. **DO NOT** use the unit if insulation is cut or worn through.
- Verify winch cables are in good condition and centered on each pulley. **DO NOT** use a cable that is kinked or starting to unravel.
- Verify the safety pins for the mast lock rod and mast lock bar are present and secured with a chain. Check that the spring located in the mast lock bar is not broken or missing. Check the operation of the mast lock bar.
- See [Figure 4-1](#). Verify correct mast cable routing.

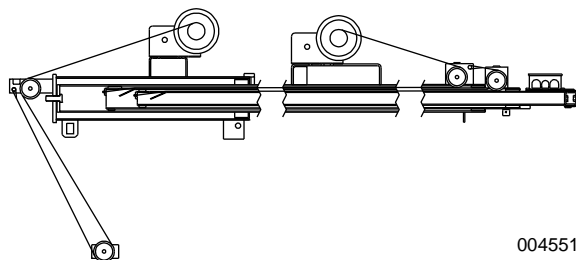

004551

Figure 4-1. Power Mast Cable Routing

- Verify the wheel lugs are present and properly tightened. Refer to **Towing Safety**.
- Check the coolant level daily by inspecting the level in coolant overflow jug located near the radiator. Refer to the engine operator’s manual for coolant recommendations and proper mixture. Normal operating level is between the ‘full’ and ‘add’ markings on the overflow jug.
- **AFTER ENGINE IS STOPPED AND COMPLETELY COOL**, coolant may be added directly to the coolant overflow jug.
- Check the oil level daily. Refer to the engine operator’s manual for the appropriate oil specification. Make sure that the oil is correct for special operating conditions such as a change in season or climate.
 - **DO NOT** start the unit if the engine oil level is below the ADD mark on the dipstick.
 - Normal operating level is in the cross-hatch pattern between the full and add markings on the dipstick.
 - Add oil only if the oil level is below the add mark on the bottom of the cross-hatch pattern on the dipstick. **DO NOT OVERFILL** the crankcase.

- Check the fuel level.
- If the unit is connected to a remote start or transfer switch, verify the remote switch is also off and tagged.

NOTE: If the engine was run out of fuel or the fuel tank was drained, it may be necessary to bleed the fuel lines. Refer to the engine operator’s manual supplied with the unit.

Basic Maintenance Schedule

Refer to the original equipment manufacturer’s operating manual for a complete list of maintenance requirements. Failure to comply with the procedures as described in the engine operator’s manual will nullify the warranty, decrease performance and cause equipment damage or premature equipment failure. Maintenance records may be required to complete a warranty request.

Use the schedule in the following table as a guide for regular maintenance intervals. For additional or replacement copies of the engine operator’s manual, contact a Generac Mobile Products Authorized Service Dealer.

Table 4-1. Basic Maintenance Guide

Item	Daily	250 Hours	500 Hours	1000 Hours
Check Oil Level	◆			
Check Coolant Level	◆			
Check Fuel Level	◆			
Drain Fuel Filter	◆			
Check Tire Pressure	◆			
Inspect Wheel Bearings	◆			
Check All Electrical Connections	◆			
Clean Battery	◆			
Check Fan Belt Tension (replace if necessary)	◆			
Inspect Radiator Fins For Debris; Clean As Required	◆			
Preheating Condition Check	◆			
Check Engine Starting Conditions and Noise Conditions	◆			
Check Exhaust Smoke Condition	◆			
Inspect Light Tower Winch For Proper Operation	◆			
Replace Engine Oil		◆		
Replace Fuel Filter Element		◆		
Clean Water Sedimenter Element		◆		
Electromagnetic Pump Filter Replacement or Cleaning		◆		
Check Fan Belt Tension (replace if necessary)			◆	
Oil Filter Element Replacement			◆	
Replace Air Filter Element			◆	
Lubricate Leveling Jacks			◆	
Replace Heated Fuel Filter (if equipped)				◆
Inspect Engine Starting Battery				◆

Resetting the Maintenance Alarms

The PowerZone–DLA will display a warning message when the unit is due for maintenance or service. The maintenance or service interval is set at 750 hours of engine running time. Once the unit has been serviced, the appropriate maintenance alarm reminder needs to be reset. The following procedure demonstrates how to reset the maintenance alarms:

1. With the unit shut down, switch the main circuit breaker ON (I). After initialization, the controller will toggle automatically to the Home screen.
2. Press \uparrow and \downarrow simultaneously to enter the navigation menu.
3. See Press \uparrow or \downarrow to move \blacktriangleright to the top of the screen. Press \checkmark to enter the Maintenance screen.
4. Press \uparrow or \downarrow to highlight the desired alarm that needs to be reset. Press \checkmark to start reset.
5. Enter the pin 4444. To do this, press \checkmark and then \uparrow or \downarrow to adjust the first number of the maintenance pin. Press \checkmark to continue to the next number.

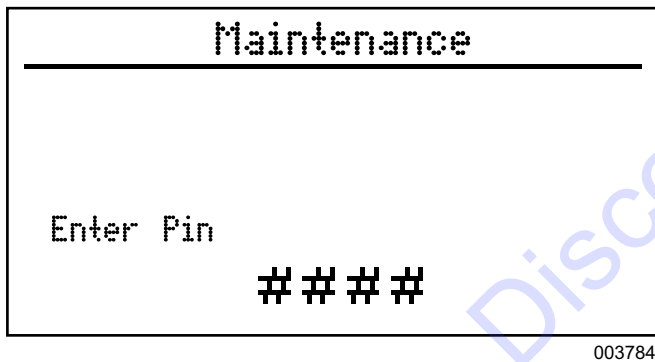

003784

Figure 4-2. Entering Maintenance Pin

Winch Use, Operation and Maintenance

Prior to Use

- Inspect rope or cable and replace if damaged.
- Check mounting hardware and tighten if necessary.
- Gears, ratchet pivot point and shaft bushings must be kept lubricated with a thin film of oil or grease.

Operation

Raising the Lights:

1. The cable must be securely fastened to the object being lifted and to the winch drum.

2. Verify the cable and cable attachments are not damaged. Contact Generac Mobile Products to order a replacement cable if necessary.
3. Referring to the “Lift / Let Down” decal on the winch, turn handle according to the specified direction to lift. The ratchet MUST make a loud clicking sound while winding the cable.

Lowering the Lights:

Referring to the “Lift / Let Down” decal on the winch, turn handle according to the specified direction to lower. No clicking will be heard because the brake system is activated.

Maintenance

The following procedures should be performed at least annually:

1. See **Figure 4-3**. The gears and bushings of the winch must be kept lubricated. Apply a thin film of grease to the gear teeth (B), and oil the bushings as needed (C).
2. The ratchet pawl pivot point must be kept lubricated with a thin oil.

NOTE: Do not get oil or grease on the friction discs (A).

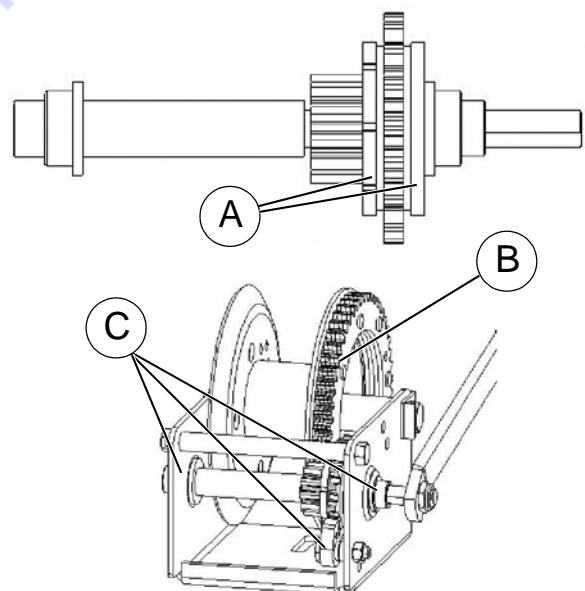

004480

Figure 4-3. Winch Maintenance

Jack Maintenance

The following procedures should be performed at least annually: For side-wind models, the internal gearing and bushings of the jack must be kept lubricated.

- See **Figure 4-4**. Apply a small amount of automotive grease (A) to the internal gearing by removing the jack cover, or if equipped, use a needle nose applicator or standard grease gun on the lubrication point found on the side of the jack near the crank. Rotate the jack handle to distribute the grease evenly.
- A lightweight oil (B) must be applied to the handle unit at both sides of the tube for side-wind models.
- If equipped, the axle bolt and nut assembly of the caster wheel must also be lubricated with the same lightweight oil.
- For top-wind models, apply a lightweight oil to the screw stem.

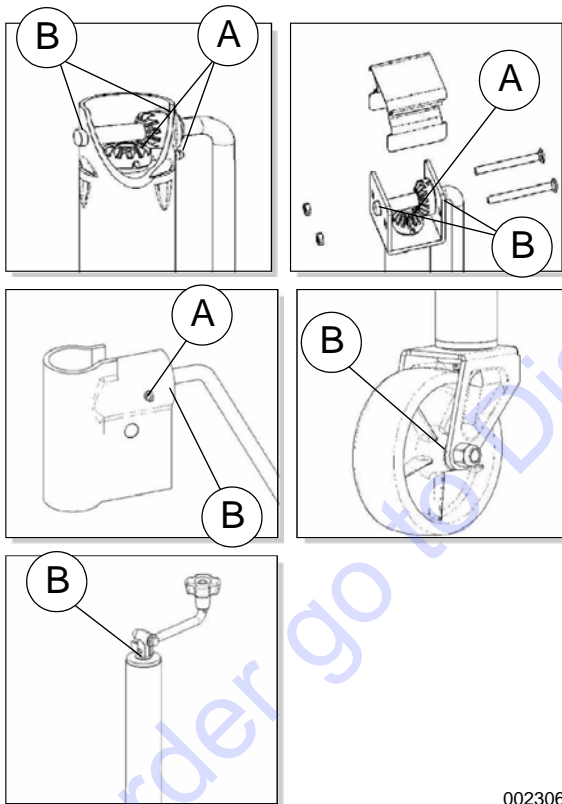

002306

Figure 4-4. Jack Maintenance

Trailer Wheel Bearings

The trailer axles are equipped with a grease zerk fitting to allow lubrication of the wheel bearings without the need to disassemble the axle hub. To lubricate the axle bearings, remove the small rubber plug on the grease cap, attach a standard grease gun fitting to the grease zerk fitting and pump grease into the fitting until new grease is visible around the nozzle of the grease gun. Use only a high quality grease made specifically for lubrication of wheel bearings. Wipe any excess grease from the hub with a clean cloth and replace the rubber plug when finished. The minimum recommended lubrication is every 12 months or 12,000 miles (19,312 km). More frequent lubrication may be required under extremely dusty or damp operating conditions.

Section 5: Troubleshooting

General Troubleshooting



WARNING

Risk of burns. Allow engine to cool before draining oil or coolant. Failure to do so could result in death or serious injury.

(000139)

Some of the more common problems are listed in the table below. This information is intended to be a check or verification that simple causes can be located and fixed. It does not cover all types of problems. Refer to the OEM engine operator's manual for additional troubleshooting information. Procedures that require in-depth knowledge or skills should be referred to a Generac Mobile Products Authorized Dealer.

Problem	Possible Cause	Solution
Unit cranks, but will not start	Fuel level low. Fuel flow obstructed. Fuel solenoid inoperable. Air in fuel system. Restricted air filter. Glow plug(s) inoperable.	Check fuel level in tank. Verify fuel pump operation. Verify fuel solenoid operation. Bleed air from fuel system. Inspect air filter for blockage. Inspect fuel supply hose from tank to fuel filter for cracks and abrasion. Check for gelled fuel in fuel system in cold weather, especially at fuel filter. Refer to OEM engine operator's manual for additional information.
Unit starts, but stumbles and dies	Ambient temperature too low. Intake heater inoperable.	Check if ambient temperature is within unit limits. Check engine air inlet heater functionality.
High coolant temperature shutdown	Low coolant level. Blockage in radiator. Debris on radiator face. broken coolant pump belt. cooling fan inoperable.	Allow engine to cool, then check coolant level in radiator. Add coolant if needed. Inspect radiator surroundings for blockage and remove any foreign matter. Inspect for visible leaks. Verify tension of water pump drive belt. Remove load on generator and restart engine. Verify coolant temperature and shut engine down immediately if it starts to overheat.
Low oil pressure shutdown	Oil level low. Oil pump inoperable.	Check oil level. Add oil if necessary.
Unit stalls when export power is used	Load exceeds unit rating.	Turn outlet breaker ON and load sense switch OFF, confirm generator output is 60hz + or - 2hz. Reapply load.
The lights are flashing	Dusk-to-dawn sensor adjustment needed. Generator frequency too low.	Adjust the dusk-to-dawn sensor to increase or decrease light received. Turn off main breaker. Check if AC frequency is >40hz.

If problems persist, contact Generac Mobile Products at 1-800-926-9768 for assistance.

Troubleshooting the Lights



WARNING

Burn hazard. Lamps become extremely hot while in use. Allow 10–15 minutes for cooling before handling or lowering mast. Touching a hot lens or fixture can cause severe burns.

(000278)

IMPORTANT NOTE: Only a qualified electrician should troubleshoot or repair electrical problems occurring in this equipment. Contact Generac Mobile Products Technical Service at 1-800-926-9768 for assistance if you have any questions, or if problems persist.



WARNING

Electrocution. Potentially lethal voltages are generated by this equipment. Render the equipment safe before attempting repairs or maintenance. Failure to do so could result in death or serious injury.

(000187)

Problem	Possible Cause	Solution
Mast Lights Off, Checking Outside the Control Box	Light fixture is too hot.	Allow light to cool 10-15 minutes before restarting.
	Faulty lamp connection.	Check that the lamp is tight in the socket.
	Lamp broken.	Check for broken arc tube or outer lamp jacket, broken or loose components in lamp envelope, or blackening/deposits inside tube.
	Loose lighting connections.	Check the connections inside the mast junction box and each mast light housing/socket.
	Damaged or loose electrical cord.	Check the mast electrical cord for damage and check the cord connections inside the control box.
Mast Lights Off, Checking Inside the Control Box	Loose lighting connections.	Check the connections inside the control box and inside each ballast box.
	Generator output incorrect.	Check the incoming voltage to the ballast by checking the available voltage on the GFCI receptacle. Incoming voltage should be 120V +/- 5V. If voltage is incorrect, the engine speed may need to be adjusted or generator may require service.
	Low transformer output.	The voltage from the transformer should read approximately 400VAC as the light "strikes" (induces an arc), then drop and slowly rise back up to stabilize at 240-260VAC. On hard wired models, remove the mast junction box cover and insert the wire probes into the connector blocks for the light and ground. If proper voltage is not achieved, perform capacitor check to determine if the capacitor or coil needs to be replaced.
Mast Lights On But the Light Output is Low	Fixture and/or lens is dirty.	Clean reflective surface inside fixture and both inside and outside surface of glass lens. Use mild soap and water to clean lens. Other chemicals may have an adverse effect on the glass.
	Lamp worn due to normal use.	Replace lamp.
	Damaged or loose electrical connections.	Check the mast coil cord, mast junction box and mast light connections.
	Generator output incorrect.	Check the incoming voltage to the ballast. Incoming voltage should be 120V +/-5V. If the voltage is incorrect, the engine speed may need to be adjusted or the generator may require service.
	Low transformer output.	The voltage from the transformer should read approximately 400VAC as the light "strikes" (induces an arc), then drop and slowly rise back up to stabilize at 240-260VAC. On hard wired models, remove the mast junction box cover and insert the wire probes into the connector blocks for the light and ground. If proper voltage is not achieved, perform capacitor check to determine if the capacitor or coil needs to be replaced.
One or more lights do not turn on	Light breaker tripped.	Check light breakers.
	Lights not turned on.	Check electronic control to see if lights are on. Turn lights on.

Section 6: Wiring Diagrams

Mast Junction Box Wiring and Light Connections

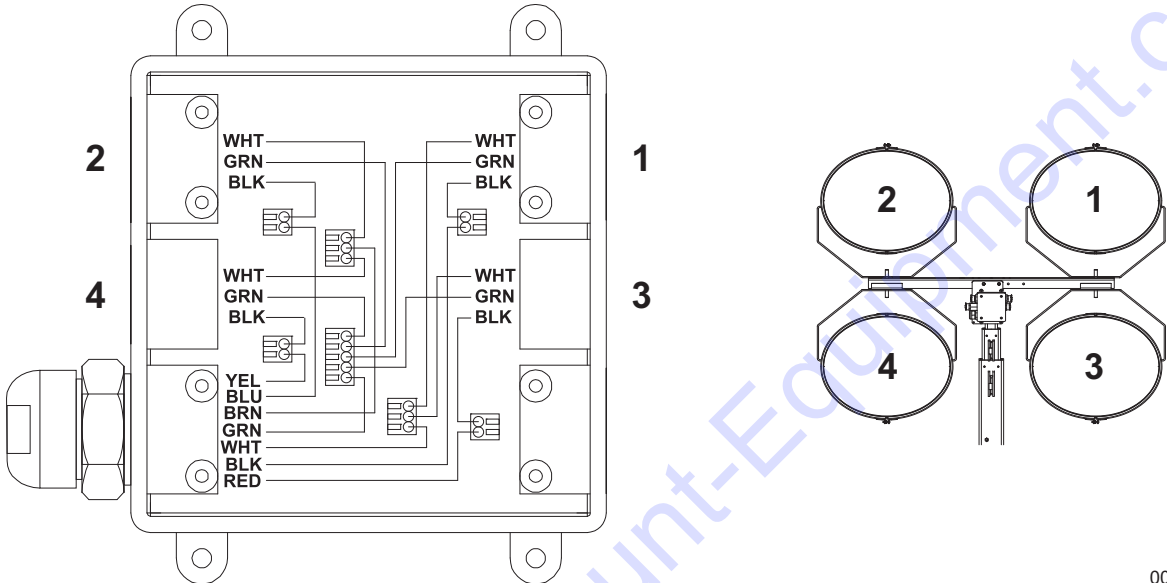

00175

To order go to Discount-Equipment.com

AC Wiring

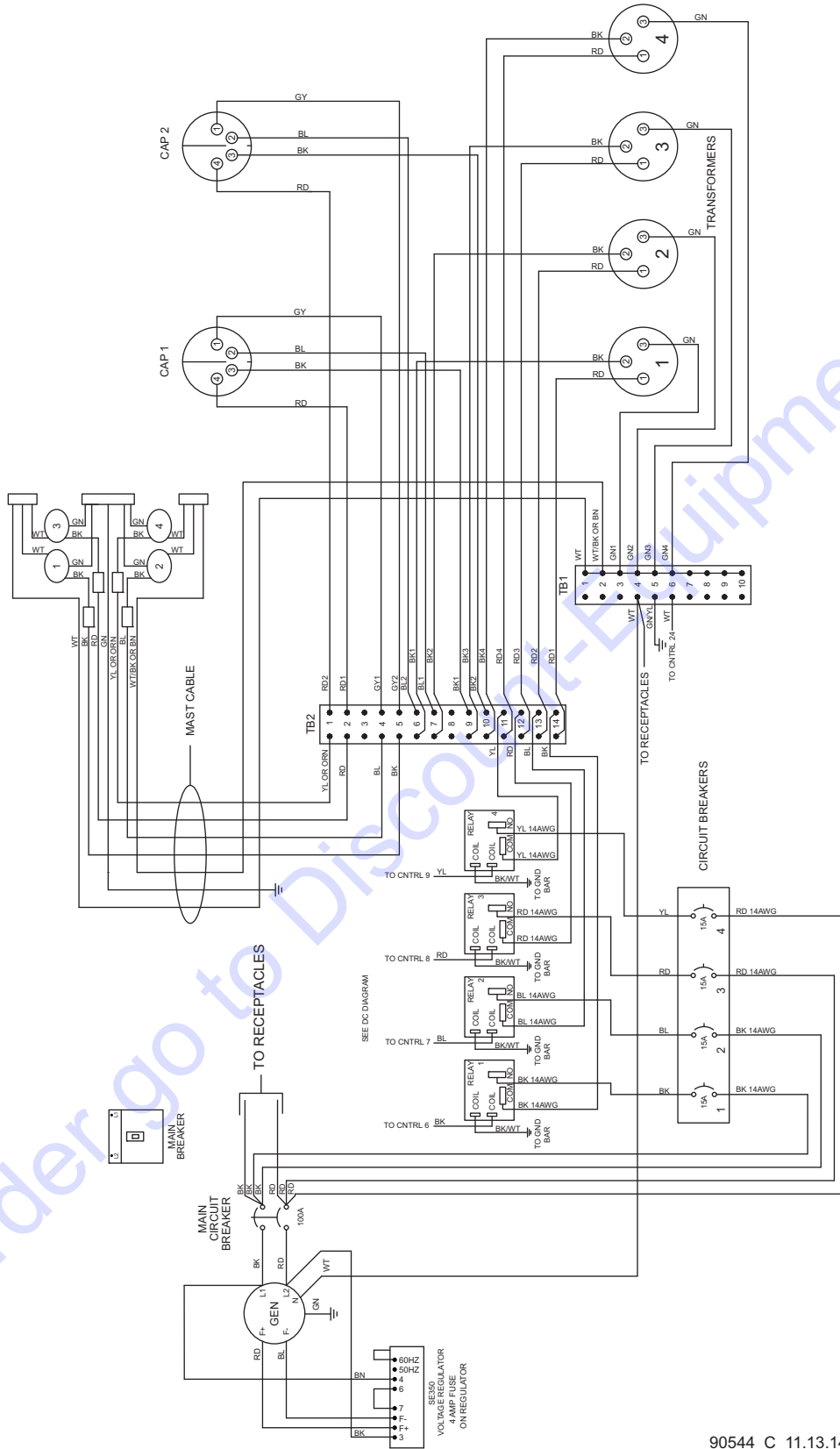

90544_C_11.13.14

AC Wiring—Receptacle Panel

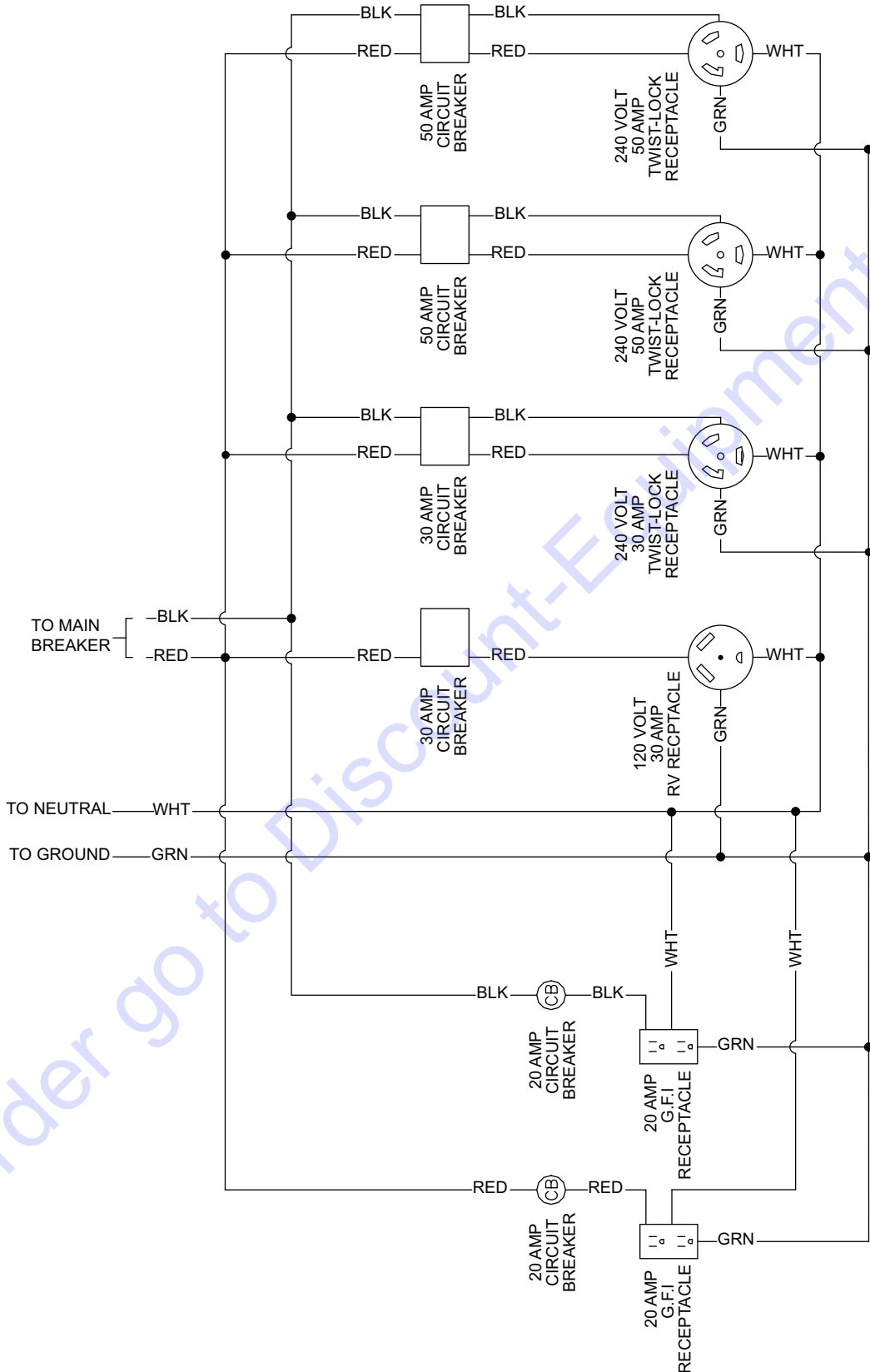

(2x5-20R, 1xTT-30, 1xL14-30R, 2x14-50)

90317_ORG_07.06.11

AC Wiring—Receptacle Panel Options (1 of 2)

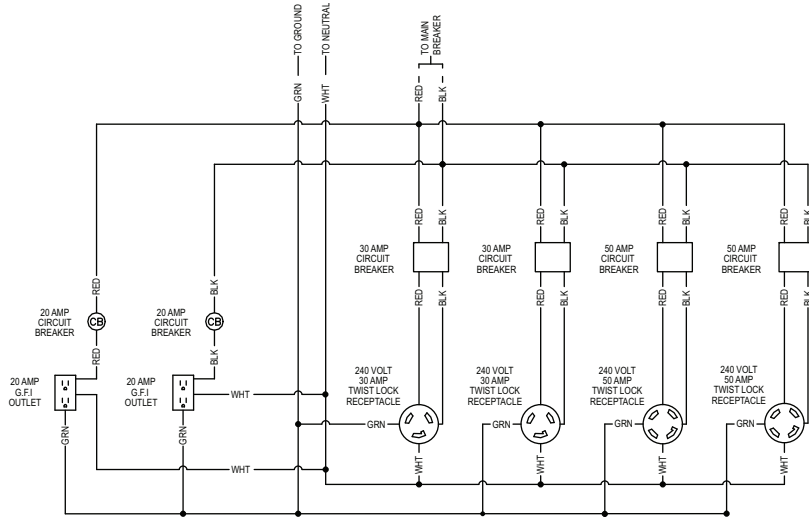

Receptacle Panel (2x5-20R, 2xL6-30R, 2xL14-50)

90315_ORG_10.14.11

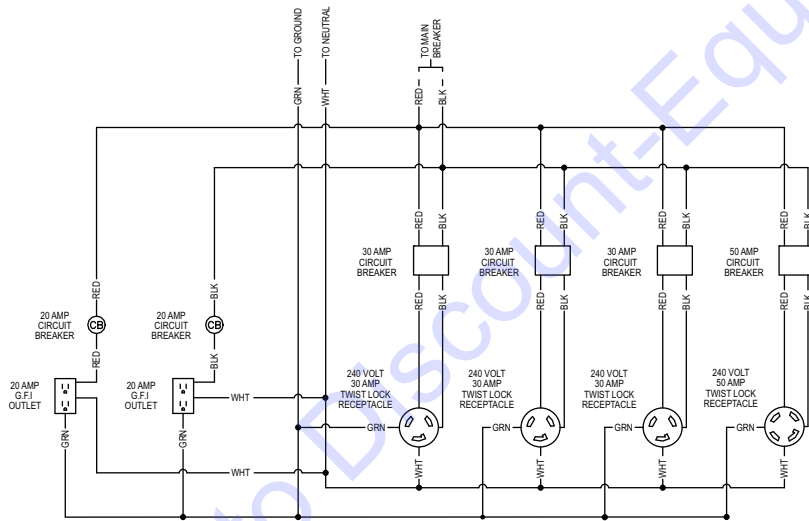

Receptacle Panel (2x5-20R, 3xL6-30R, 1xL14-50)

90318_ORG_07.06.11

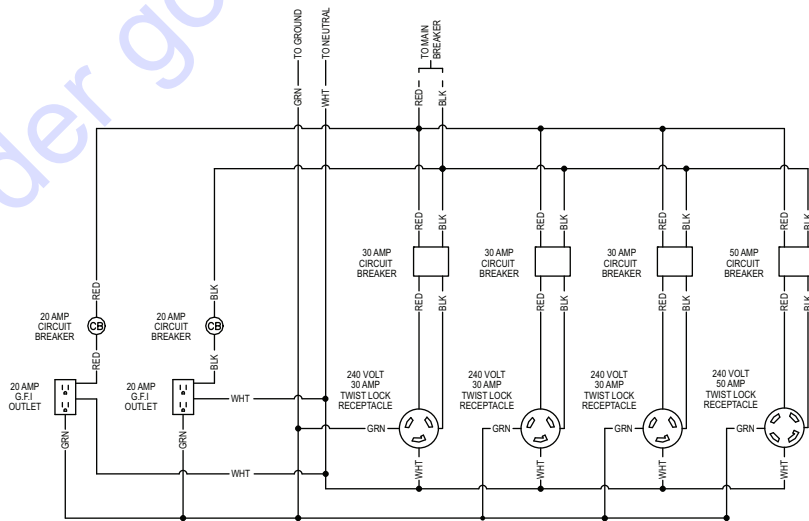

Receptacle Panel (2x5-20R, 3xL6-30R, 1xL14-50)

90318_ORG_07.06.11

AC Wiring—Receptacle Panel Options (2 of 2)

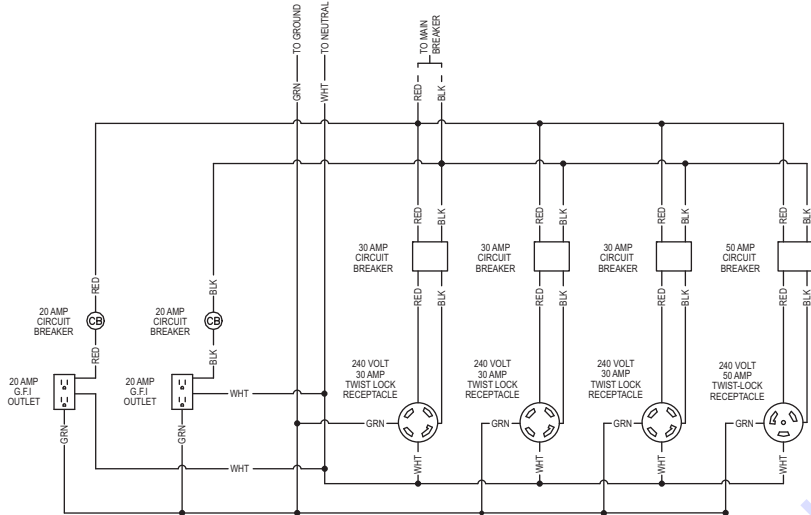

Receptacle Panel (2x5-20R, 3xL14-30R, 1x50A)

90320_ORG_07.06.11

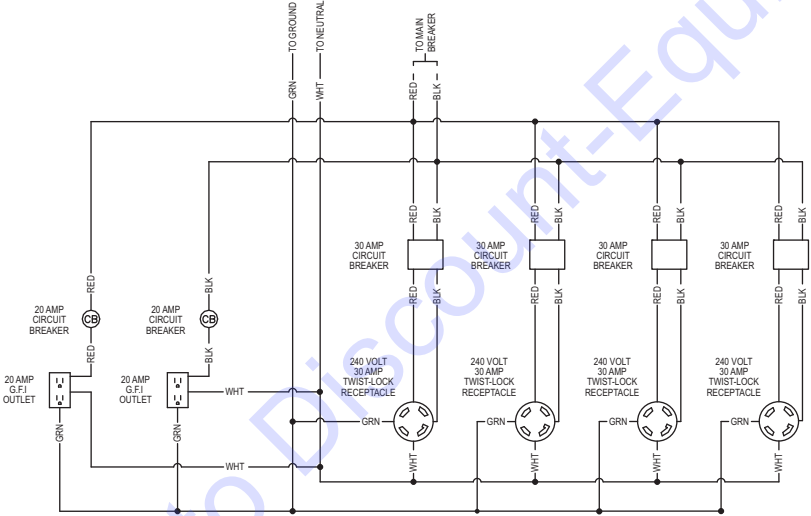

Receptacle Panel (2x5-20R, 4xL14-30R)

90321_ORG_07.06.11

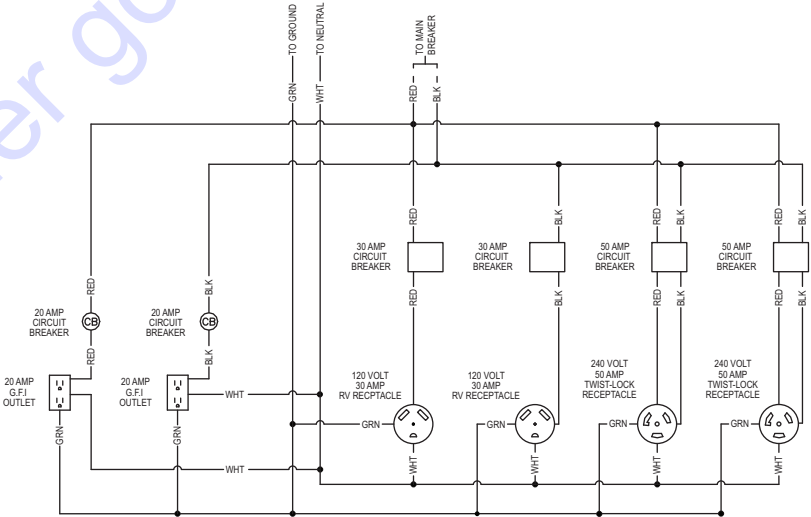

Receptacle Panel (2x5-20R, 2xTT-30, 2x14-50)

90355_ORG_07.06.11

DC Wiring

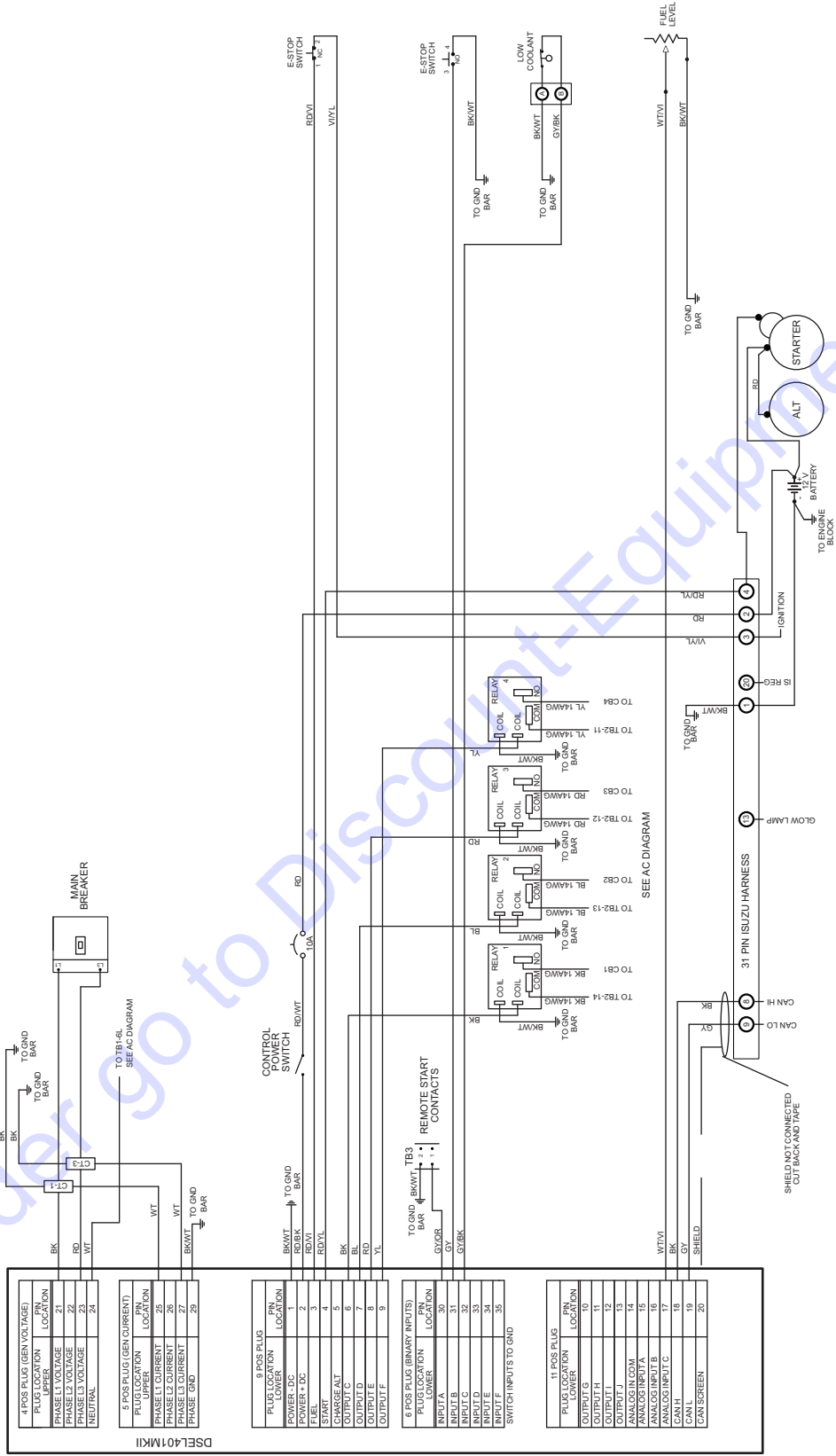

90545_B_11.14.14

DC Wiring for Optional Equipment

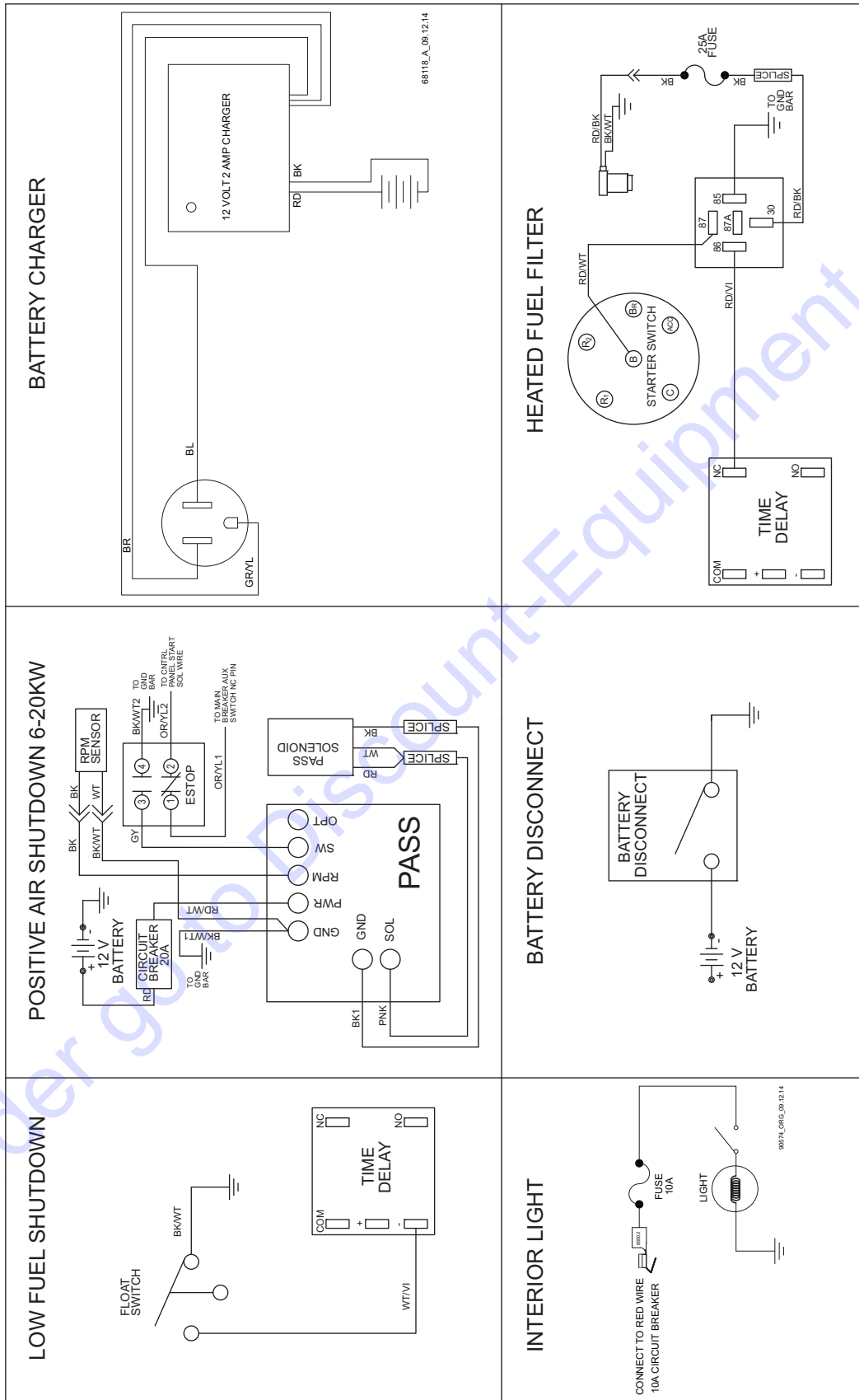

90323_K_06.04.14

Trailer Lights Wiring

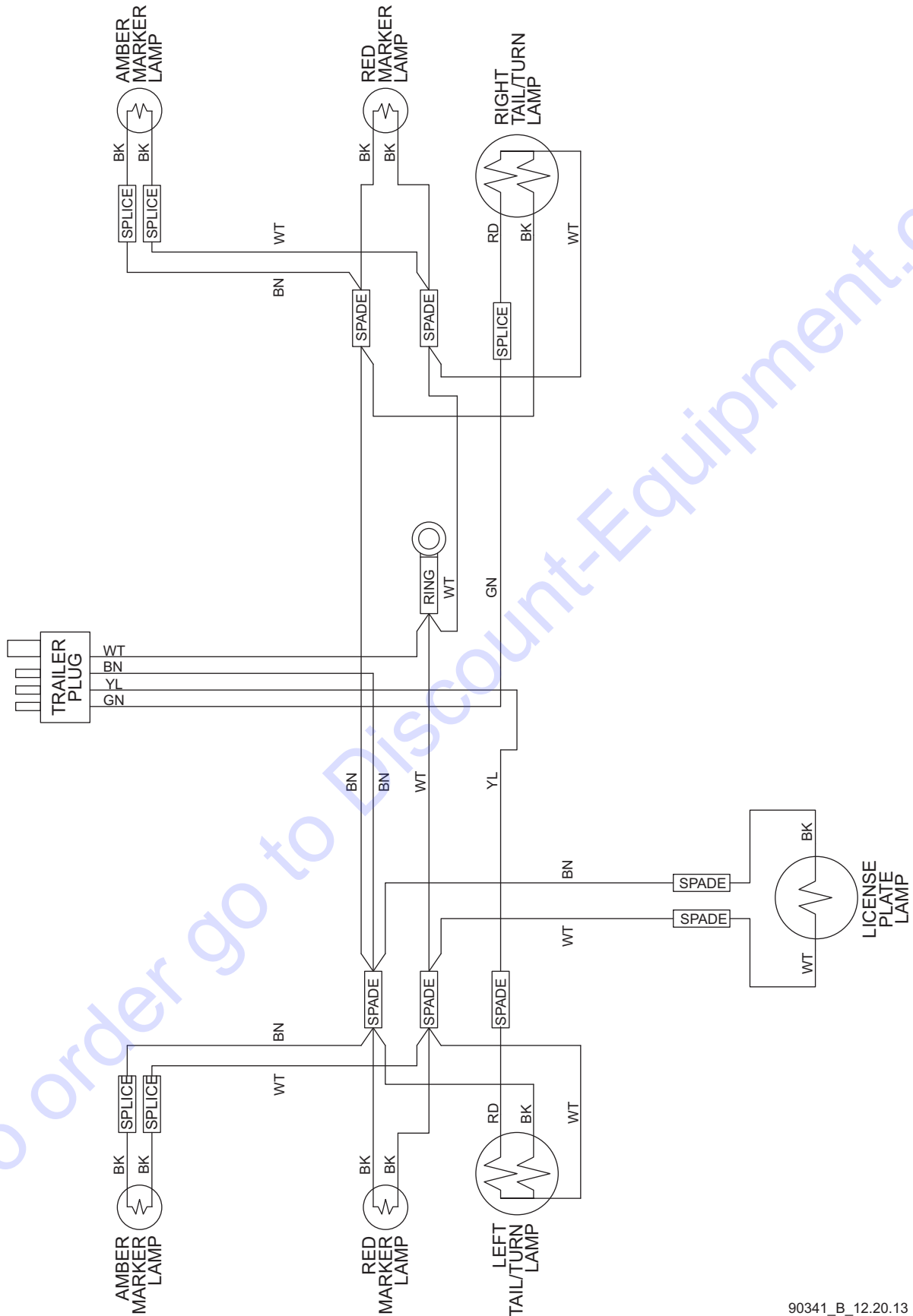

90341_B_12.20.13

This page intentionally left blank.

To order go to DiscountEquipment.com

This page intentionally left blank.

To order go to DiscountEquipment.com

This page intentionally left blank.

To order go to DiscountEquipment.com

To order go to Discount-Equipment.com

To order go to Discount-Equipment.com

Part No. 37096 Rev. B 3/24/17

©2017 Generac Mobile Products

All rights reserved.

Specifications are subject to change without notice.

No reproduction allowed in any form without prior written consent from Generac Mobile Products.

GENERAC[®]

MAGNUM

TO PURCHASE THIS PRODUCT PLEASE CONTACT US



**Equipment Financing and
Extended Warranties Available**



**Discount-Equipment.com is your online resource for
commercial and industrial quality parts and equipment sales.**

561-964-4949

visit us on line @ www.discount-equipment.com

Select an option below to find your Equipment

Search by Manufacturer

Search by Product Type

Request a Quote

We sell worldwide for the brands: Genie, Terex, JLG, MultiQuip, Mikasa, Essick, Whiteman, Mayco, Toro Stone, Diamond Products, Generac Magnum, Airman, Haulotte, Barreto, Power Blanket, Nifty Lift, Atlas Copco, Chicago Pneumatic, Allmand, Miller Curber, Skyjack, Lull, Skytrak, Tsurumi, Husquvarna Target, Stow, Wacker, Sakai, Mi-T-M, Sullair, Basic, Dynapac, MBW, Weber, Bartell, Bennar Newman, Haulotte, Ditch Runner, Menegotti, Morrison, Contec, Buddy, Crown, Edco, Wyco, Bomag, Laymor, EZ Trench, Bil-Jax, F.S. Curtis, Gehl Pavers, Heli, Honda, ICS/PowerGrit, IHI, Partner, Imer, Clipper, MMD, Koshin, Rice, CH&E, General Equipment, Amida, Coleman, NAC, Gradall, Square Shooter, Kent, Stanley, Tamco, Toku, Hatz, Kohler, Robin, Wisconsin, Northrock, Oztec, Toker TK, Rol-Air, APT, Wylie, Ingersoll Rand / Doosan, Innovatech, Con X, Ammann, Mecalac, Makinex, Smith Surface Prep, Small Line, Wanco, Yanmar