

*Owner's Manual*  
*Light Tower*

**MLT4060MV • MLT4060KV • MLT4080KV**

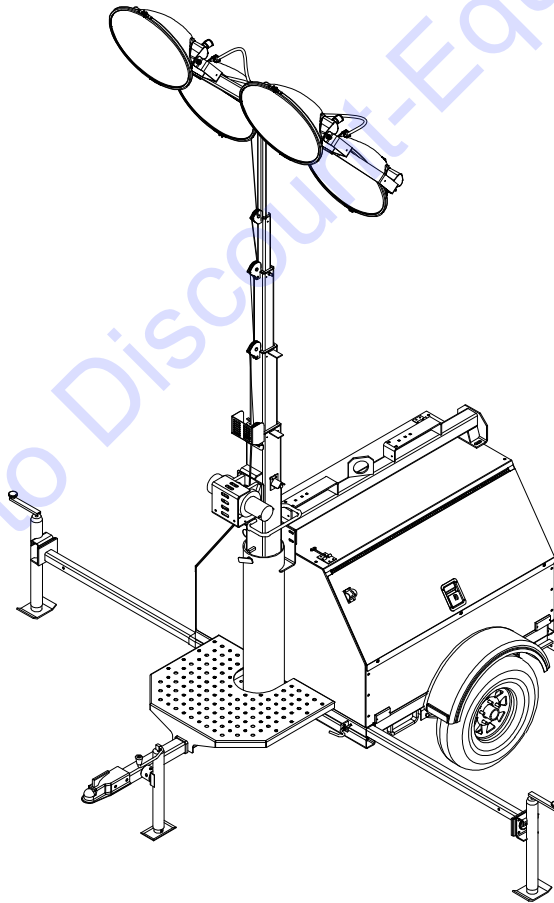

**TO PURCHASE THIS PRODUCT PLEASE CONTACT US**



**Equipment Financing and  
Extended Warranties Available**



**Discount-Equipment.com is your online resource for  
commercial and industrial quality parts and equipment sales.**

**561-964-4949**

**visit us on line @ [www.discount-equipment.com](http://www.discount-equipment.com)**

Select an option below to find your Equipment

**Search by Manufacturer**

**Search by Product Type**

**Request a Quote**

We sell worldwide for the brands: Genie, Terex, JLG, MultiQuip, Mikasa, Essick, Whiteman, Mayco, Toro Stone, Diamond Products, Generac Magnum, Airman, Haulotte, Barreto, Power Blanket, Nifty Lift, Atlas Copco, Chicago Pneumatic, Allmand, Miller Curber, Skyjack, Lull, Skytrak, Tsurumi, Husquvarna Target, Stow, Wacker, Sakai, Mi-T-M, Sullair, Basic, Dynapac, MBW, Weber, Bartell, Bennar Newman, Haulotte, Ditch Runner, Menegotti, Morrison, Contec, Buddy, Crown, Edco, Wyco, Bomag, Laymor, EZ Trench, Bil-Jax, F.S. Curtis, Gehl Pavers, Heli, Honda, ICS/PowerGrit, IHI, Partner, Imer, Clipper, MMD, Koshin, Rice, CH&E, General Equipment, Amida, Coleman, NAC, Gradall, Square Shooter, Kent, Stanley, Tamco, Toku, Hatz, Kohler, Robin, Wisconsin, Northrock, Oztec, Toker TK, Rol-Air, APT, Wylie, Ingersoll Rand / Doosan, Innovatech, Con X, Ammann, Mecalac, Makinex, Smith Surface Prep, Small Line, Wanco, Yanmar

---

## Use this page to record important information about your Light Tower

Unit Model Number	
Unit Serial Number	
Engine Model Number	
Engine Serial Number	
Generator Model Number	
Generator Serial Number	

Record the information found on your unit data label on this page. See unit serial number location ([Unit Serial Number Locations](#)). The label plate is affixed to the inside partition, to the left of the control panel console.

Engine and generator serial numbers are located on separate data plates affixed to the engine and generator respectively.

When contacting an Generac Mobile Products Authorized Service Dealer about parts and service, always supply the complete model number and serial number of the unit.

**Operation and Maintenance:** Proper maintenance and care of the Light Tower ensures a minimum number of problems and keeps operating expenses at a minimum. It is the operator's responsibility to perform all safety checks, to verify that all maintenance for safe operation is performed promptly, and to have the equipment checked periodically by a Generac Mobile Products Authorized Service Dealer. Normal maintenance, service and replacement of parts are the responsibility of the owner or operator and, as such, are not considered defects in materials or workmanship within the terms of the warranty. Individual operating habits and usage may contribute to the need for additional maintenance or service.

---

**⚠ WARNING**

California Proposition 65. Engine exhaust and some of its constituents are known to the state of California to cause cancer, birth defects, and other reproductive harm. (000004)

---

**⚠ WARNING**

California Proposition 65. This product contains or emits chemicals known to the state of California to cause cancer, birth defects, and other reproductive harm. (000005)

---

# Table of Contents

## **Section 1: Introduction and Safety**

<b>Introduction</b> .....	1
Read This Manual Thoroughly .....	1
How to Obtain Service .....	1
<b>Safety Rules</b> .....	1
<b>General Hazards</b> .....	2
<b>Explosion and Fire Hazards</b> .....	2
<b>Trailer Hazards</b> .....	2
<b>Electrical Hazards</b> .....	3
<b>Battery Hazards</b> .....	3
<b>Fuel Hazards</b> .....	4
<b>Engine Safety</b> .....	4
<b>Operating Safety</b> .....	4
Positioning the Unit .....	4
Starting the Unit .....	4
Raising and Lowering the Mast .....	5
<b>Service Safety</b> .....	5
<b>Towing Safety</b> .....	6
Hitch and Coupling .....	6
Running Lights .....	6
Wheels and Tires .....	6
Safe Towing Techniques .....	6
<b>Reporting Trailer Safety Defects</b> .....	6

## **Section 2: General Information**

<b>Specifications</b> .....	7
<b>Unit Dimensions</b> .....	9
<b>Unit Serial Number Locations</b> .....	10
<b>Component Locations</b> .....	11
<b>Control Panel - MLT4060MV, MLT4060KV</b> .....	12
Control Panel Features and Functions .....	13
<b>Control Panel - MLT4080KV</b> .....	14
Control Panel Features and Functions .....	15

## **Section 3: Operation**

<b>Light Tower Setup</b> .....	17
<b>Prestart Checklist</b> .....	18
<b>Raising the Mast</b> .....	18
<b>Starting the Unit</b> .....	19

<b>Automatic Shutdown</b> .....	20
<b>Light Operation</b> .....	20
<b>Voltage Regulation Option</b> .....	21
<b>Auxiliary Outlets</b> .....	21
<b>Wet Stacking</b> .....	21
<b>Engine Derating</b> .....	21
<b>Shutting Down the Unit</b> .....	21
<b>Lowering the Mast</b> .....	22
Lowering the Mast—Manually .....	22
<b>Towing the Unit</b> .....	22
<b>Lifting the Unit</b> .....	23

## **Section 4: Maintenance**

<b>Emissions Information</b> .....	25
<b>Daily Walk-Around Inspection</b> .....	25
<b>General Maintenance</b> .....	25
Preparing for Service .....	25
Cleaning the Unit .....	25
Inspecting the Unit .....	25
<b>Basic Maintenance Schedule</b> .....	26
<b>Winch Use, Operation and Maintenance</b> .....	28
Winch Mechanical Brake .....	28
<b>Optional Lower Radiator Hose Heater Use and Maintenance</b> .....	29
<b>Trailer Wheel Bearings</b> .....	29
<b>Jack Maintenance</b> .....	29

## **Section 5: Troubleshooting**

<b>General Troubleshooting</b> .....	31
<b>Troubleshooting the Lights</b> .....	32

## **Section 6: Wiring Diagrams**

<b>Mast Junction Box Wiring and Light Connections</b> .....	33
<b>AC Wiring Diagram</b> .....	34
<b>DC Wiring Diagram—Mitsubishi</b> .....	35
<b>DC Wiring Diagram—Kubota</b> .....	36
<b>DC Wiring Diagram—Electric Winch</b> .....	37

---

DC Wiring Diagrams for Optional Equipment . 38  
Trailer Lights Wiring ..... 39

**Section 7: Service Log**

To order go to [Discount-Equipment.com](http://Discount-Equipment.com)

# Section 1: Introduction and Safety

## Introduction

Thank you for purchasing a Generac Mobile Products LLC product. This unit has been designed to provide high performance, efficient operation, and years of use when maintained properly.

The information in this manual is accurate based on products produced at the time of publication. The manufacturer reserves the right to make technical updates, corrections, and product revisions at any time without notice.

### Read This Manual Thoroughly



#### **⚠ WARNING**

Consult Manual. Read and understand manual completely before using product. Failure to completely understand manual and product could result in death or serious injury. (000100a)

The owner is responsible for proper maintenance and safe use of the equipment. Comply with regulations the Occupational Safety and Health Administration (OSHA) has established, or with equivalent standards. Also, verify that the unit is applied, used, and maintained in accordance with the manufacturer's instructions and recommendations. Do nothing that might alter safe application/usage and render the unit in noncompliance with the aforementioned codes, standards, laws, and regulations.

Save these instructions for future reference. This manual contains important instructions for the unit that should be followed during setup, operation and maintenance of the unit and battery. ALWAYS supply this manual to any individual that will use this machine.

## Safety Rules

The manufacturer cannot anticipate every possible circumstance that might involve a hazard. The warnings in this manual, and on tags and decals affixed to the unit are, therefore, not all inclusive. If using a procedure, work method or operating technique that the manufacturer does not specifically recommend, verify that it is safe for others. Also make sure the procedure, work method or operating technique utilized does not render the equipment unsafe.

Throughout this publication, and on tags and decals affixed to the unit, DANGER, WARNING, CAUTION and NOTE blocks are used to alert personnel to special instructions about a particular operation that may be hazardous if performed incorrectly or carelessly. Observe them carefully. Their definitions are as follows:

#### **⚠ DANGER**

Indicates a hazardous situation which, if not avoided, will result in death or serious injury.

(000001)

#### **⚠ WARNING**

Indicates a hazardous situation which, if not avoided, could result in death or serious injury.

(000002)

#### **⚠ CAUTION**

Indicates a hazardous situation which, if not avoided, could result in minor or moderate injury.

(000003)

**NOTE:** Notes contain additional information important to a procedure and will be found within the regular text of this manual.

These safety alerts cannot eliminate the hazards that they indicate. Common sense and strict compliance with the special instructions while performing the action or service are essential to preventing accidents.

## General Hazards



**⚠ DANGER**

Asphyxiation. Running engines produce carbon monoxide, a colorless, odorless, poisonous gas. Carbon monoxide, if not avoided, will result in death or serious injury. (000103)



**⚠ WARNING**

Hearing Loss. Hearing protection is recommended when using this machine. Failure to wear hearing protection could result in permanent hearing loss. (000107)



**⚠ WARNING**

Moving Parts. Keep clothing, hair, and appendages away from moving parts. Failure to do so could result in death or serious injury. (000111)



**⚠ WARNING**

Hot Surfaces. When operating machine, do not touch hot surfaces. Keep machine away from combustibles during use. Hot surfaces could result in severe burns or fire. (000108)

**⚠ WARNING**

Risk of injury. Do not operate or service this machine if not fully alert. Fatigue can impair the ability to service this equipment and could result in death or serious injury. (000215)



**⚠ WARNING**

Risk of burns. Allow engine to cool before draining oil or coolant. Failure to do so could result in death or serious injury. (000139)

## Explosion and Fire Hazards



**⚠ DANGER**

Explosion and Fire. Fuel and vapors are extremely flammable and explosive. Add fuel in a well ventilated area. Keep fire and spark away. Failure to do so will result in death or serious injury. (000105)



**⚠ WARNING**

Risk of Fire. Unit must be positioned in a manner that prevents combustible material accumulation underneath. Failure to do so could result in death or serious injury. (000147)



**⚠ WARNING**

Risk of Fire. Hot surfaces could ignite combustibles, resulting in fire. Fire could result in death or serious injury. (000110)

## Trailer Hazards

**⚠ WARNING**

Trailer must be securely coupled to the hitch and the chains correctly attached. Uncoupled or unchained towing could result in death or serious injury. (000233)

**⚠ WARNING**

Do not operate this unit while transporting. Doing so could result in death or serious injury. (000231)

**⚠ WARNING**

Crushing hazard. Verify unit is properly secured and on level ground. An unsecured unit can suddenly roll or move, causing death or serious injury. (000234a)

**⚠ WARNING**

Property or Equipment Damage. Tighten wheel lug nuts after first 50 miles to factory specifications. Failure to do so could result in death, serious injury, property or equipment damage. (000235)

## Electrical Hazards



**⚠ DANGER**

Electrocution. In the event of electrical accident, immediately shut power OFF. Use non-conductive implements to free victim from live conductor. Apply first aid and get medical help. Failure to do so will result in death or serious injury. (000145)



**⚠ DANGER**

Electrocution. Water contact with a power source, if not avoided, will result in death or serious injury.

(000104)



**⚠ DANGER**

Electrocution. Contact with bare wires, terminals, and connections while generator is running will result in death or serious injury.

(000144)



**⚠ DANGER**

Electrocution. Verify electrical system is properly grounded before applying power. Failure to do so will result in death or serious injury.

(000152)



**⚠ DANGER**

Electrocution. Do not wear jewelry while working on this equipment. Doing so will result in death or serious injury.

(000188)



**⚠ DANGER**

Electrocution. DO NOT use the unit if electrical cord is cut or worn through. Doing so will result in death or serious injury.

(000263a)

## Battery Hazards



**⚠ DANGER**

Electrocution. Do not wear jewelry while working on this equipment. Doing so will result in death or serious injury.

(000188)



**⚠ WARNING**

Explosion. Batteries emit explosive gases while charging. Keep fire and spark away. Wear protective gear when working with batteries. Failure to do so could result in death or serious injury.

(000137a)



**⚠ WARNING**

Explosion. Do not dispose of batteries in a fire. Batteries are explosive. Electrolyte solution can cause burns and blindness. If electrolyte contacts skin or eyes, flush with water and seek immediate medical attention.

(000162)



**⚠ WARNING**

Risk of burn. Do not open or mutilate batteries. Batteries contain electrolyte solution which can cause burns and blindness. If electrolyte contacts skin or eyes, flush with water and seek immediate medical attention.

(000163a)

**⚠ WARNING**

Environmental Hazard. Always recycle batteries at an official recycling center in accordance with all local laws and regulations. Failure to do so could result in environmental damage, death or serious injury.

(000228)

Always recycle batteries in accordance with local laws and regulations. Contact your local solid waste collection site or recycling facility to obtain information on local recycling processes. For more information on battery recycling, visit the Battery Council International website at: <http://batteryCouncil.org>



## Fuel Hazards



### ⚠ DANGER

Explosion and fire. Fuel and vapors are extremely flammable and explosive. No leakage of fuel is permitted. Keep fire and spark away. Failure to do so will result in death or serious injury. (000192)



### ⚠ DANGER

Risk of fire. Allow fuel spills to completely dry before starting engine. Failure to do so will result in death or serious injury. (000174)

- **DO NOT** fill fuel tank near an open flame, while smoking, or while engine is running. **DO NOT** fill tank in an enclosed area with poor ventilation.
- **DO NOT** operate with the fuel tank cap loose or missing.

## Engine Safety

Internal combustion engines present special hazards during operation and fueling. Failure to follow the safety guidelines described below could result in severe injury or death. Read and follow all safety alerts described in the engine operator's manual. A copy of this manual was supplied with the unit when it was shipped from the factory.

- **DO NOT** run engine indoors or in an area with poor ventilation. Make sure engine exhaust cannot seep into closed rooms or ventilation equipment.
- **DO NOT** clean air filter with gasoline or other types of low flash point solvents.
- **DO NOT** operate the unit without a functional exhaust system.
- Shut the engine down if any of the following conditions exist during operation:
  - Noticeable change in engine speed.
  - Loss of electrical output.
  - Equipment connected to the unit overheats.
  - Sparking occurs.
  - Engine misfires or there is excessive engine/generator vibration.
  - Protective covers are loose or missing.
  - Ambient air temperature is above 120°F (49°C).

## Operating Safety

### Positioning the Unit



### ⚠ DANGER

High Voltage. Verify area above unit is clear of overhead wires and obstructions. Contact with high-voltage power lines will result in death or serious injury. (000260a)



### ⚠ WARNING

Burn hazard. Never operate lights with a damaged or missing lens cover. Lamps are hot and pressurized while in use. Unprotected lamps can shatter, causing severe injury. (000277)

- The area immediately surrounding the unit should be dry, clean, and free of debris.
- Position and operate the unit on a firm, level surface.
- If the unit is equipped with a frame grounding stud, follow the National Electrical Code (NEC), state, and local guidelines when connecting.

### Starting the Unit



### ⚠ DANGER

Electrocution. **DO NOT** use the unit if electrical cord is cut or worn through. Doing so will result in death or serious injury. (000263a)

### ⚠ WARNING

Equipment damage. Do not attempt to start or operate a unit in need of repair or scheduled maintenance. Doing so could result in serious injury, death, or equipment failure or damage. (000291)

## Raising and Lowering the Mast



### ⚠️ WARNING

Electrocution. Do not set up or operate this unit if severe weather is expected. Lightning strikes can kill or cause severe injury even if you are not touching the unit. (000296)



### ⚠️ WARNING

> 60 mph Do not set up the unit if high winds are expected. High winds can cause the unit to tip or fall, causing severe injury or machine damage. (000297)

### ⚠️ WARNING

Personal injury or equipment damage. Do not raise or lower the mast while the unit is operating. Doing so can break the lenses and cause the lamps to shatter. (000279)

### ⚠️ WARNING

Personal Injury. Stop immediately if the mast hangs up or the winch cable develops slack. Excess slack could cause the mast to collapse, resulting in personal injury or equipment damage. (000265)

### ⚠️ WARNING

Tipping hazard. Extend the outriggers and level the unit before raising the mast. Keep the outriggers extended while the mast is up. Failure to do so could cause the unit to tip and fall and could result in death or serious injury. (000266)



### ⚠️ WARNING

Burn hazard. Lamps become extremely hot while in use. Allow 10–15 minutes for cooling before handling or lowering mast. Touching a hot lens or fixture can cause severe burns. (000278)

- Keep area around the unit clear of people while raising and lowering the mast.
- **ALWAYS** lower the mast when not in use.
- The tower extends up to 25 ft (7.4 m). Make sure area above trailer is open and clear of overhead wires and obstructions.
- If for any reason any part of mast hangs up or winch cable develops slack while raising or lowering tower, STOP immediately! Contact a Generac Mobile Products Authorized Service Dealer.
- **NEVER** remove safety pin or pull mast locking pin while tower is up.

## Service Safety

This unit uses high voltage circuits capable of causing serious injury or death. Only a qualified and licensed electrician should troubleshoot or repair problems occurring in this equipment.

- Before servicing the unit, verify the Control Power switch and circuit breakers are in the OFF (O) position, and the negative (-) terminal on the battery is disconnected. **DO NOT** perform even routine service (oil/filter changes, cleaning, etc.) unless all electrical components are shut down.
- **ALWAYS** use extreme caution when servicing this unit in damp conditions. Do not service the unit if your skin or clothing is wet. Do not allow water to collect around the base of the unit.
- **DO NOT** wash the unit with high pressure hoses, power washers, or steam cleaners. Water may collect in the unit, causing damage to electrical parts.
- Replace all missing and hard to read decals. Decals provide important operating instructions and warn of dangers and hazards.
- Wear heavy leather gloves when handling winch cables. Never let cables slip through bare hands.
- Only use mild soap and water to clean the lens covers. Other chemicals may damage the lens covers.
- Make sure slings, chains, hooks, ramps, jacks and other types of lifting devices are attached securely and have enough weight-bearing capacity to lift or hold the equipment safely. Always remain aware of the position of other people around you when lifting the equipment.

## Towing Safety

Towing a trailer requires care. Both the trailer and vehicle must be in good condition and securely fastened to each other to reduce the possibility of an accident. Some states require that large trailers be registered and licensed. Contact your local Department of Transportation office to check on license requirements for your particular unit.

### Hitch and Coupling

- Verify the hitch and coupling on the towing vehicle are rated equal to, or greater than, the trailer's Gross Vehicle Weight Rating (GVWR).
- Verify the trailer hitch and the coupling are compatible. Make sure the coupling is securely fastened to the vehicle.
- **DO NOT** tow trailer using defective parts. Inspect the hitch and coupling for wear or damage.
- Connect safety chains in a crossing pattern under the tongue.
- Before towing the trailer, verify that the weight of the trailer is equal across all tires. On trailers with adjustable height hitches, adjust the angle of the trailer tongue to keep the trailer as level as possible.
- Attach the breakaway cable to the rear bumper of the towing vehicle.

### Running Lights

Verify directional and brake lights on the trailer are connected and working properly

### Wheels and Tires

- Check trailer tires for wear and proper inflation.
- Verify wheel lug nuts are present and tightened to the specified torque.

### Safe Towing Techniques

- Practice turning, stopping and backing up in an area away from heavy traffic prior to transporting the unit.
- Maximum recommended speed for highway towing is 45 mph (72 km/h). Recommended off-road towing speed is 10 mph (16 km/h) or less, depending on terrain.
- When towing, maintain extra space between vehicles and avoid soft shoulders, curbs and sudden lane changes.

## Reporting Trailer Safety Defects

If you believe your trailer has a defect which could cause a crash or could cause injury or death, you should immediately inform the National Highway Traffic Safety Administration (NHTSA) in addition to notifying Generac Mobile Products LLC.

If NHTSA receives similar complaints, it may open an investigation; and if it finds that a safety defect exists in a group of vehicles, it may order a recall and remedy campaign. However, NHTSA cannot become involved in an individual problem between you, your dealer, or Generac Mobile Products LLC.

To contact NHTSA, you may either call the Auto Safety Hotline toll-free at 1-888-327-4236 (TTY:1-800-424-9153), go to <http://www.safercar.gov>; or write to:

Administrator  
NHTSA  
1200 New Jersey Avenue S.E.  
Washington, DC 20590

You can also obtain other information about motor vehicle safety from <http://www.safercar.gov>.

## Section 2: General Information

### Specifications

DESCRIPTION	UNITS	MLT3060MV	MLT3060KV
<b>Engine</b>			
Make/Brand	—	MITSUBISHI	KUBOTA
Model	—	L3E-W461ML	D1005-E3BG1-MGM-1
EPA Tier	—	4F	4F
Type	—	Diesel, liquid cooled, 4-stroke	
Horsepower - prime	hp (kW)	10.5 (7.8)	11.7 (8.7)
Horsepower - standby	hp (kW)	12.2 (9.1)	13.1 (9.8)
Operating Speed	rpm	1800	1800
Displacement	in <sup>3</sup> (L)	57.97 (0.95)	61.08 (1.00)
Cylinders	qty	3	3
Fuel Consumption—100% Prime	gph (Lph)	0.47 (1.78)	0.50 (1.89)
Battery Type—Group Number	—	24	24
Battery Voltage	quantity per unit	12V (1)	12V (1)
Battery Rating	CCA-hour	440	440
<b>Generator</b>			
Make/Brand	—	Marathon Electric	Marathon Electric
Model	—	201CSA5411	201CSA5411
Type, Insulation	—	Brushless, F	Brushless, F
Output	kW (kVA)	6.0 (6.0)	6.0 (6.0)
Output Voltage	volts	120/240, single phase	120/240, single phase
Output Amperes <b>120V (240V)</b>	amperes	50 (25)	50 (25)
Frequency <b>Hz</b>	Hertz	60	60
Power Factor	—	1 (1Ø)	1 (1Ø)
Sound (23 ft at prime)	dB (A)	70	70
<b>Weights</b>			
Dry Weight	lbs (kg)	1759 (798)	1779 (807)
Operating Weight	lbs (kg)	2162 (981)	2182 (990)
<b>Capacities</b>			
Fuel Tank Volume	gal (L)	56 (212)	56 (212)
Usable Fuel Volume	gal (L)	56 (212)	56 (212)
Coolant (including engine)	qt (L)	4.5 (4.3)	4.8 (4.5)
Oil (including filter)	qt (L)	3.8 (3.6)	5.4 (5.1)
Maximum Run Time	hours	119	112
<b>AC Distribution</b>			
Circuit Breaker Size	amperes	30	30
Voltage Regulation	—	Capacitor +/-6%	Capacitor +/-6%
Voltages Available 1Ø	—	120, 240	120, 240
<b>Lighting</b>			
Lighting Type	—	Metal Halide	Metal Halide
Ballast Type	—	Coil & Core	Coil & Core
Lumens	—	440,000-462,000	440,000-462,000
Coverage	acres (m <sup>2</sup> )	5-7 (20,234 - 28,328)	5-7 (20,234 - 28,328)
<b>Trailer</b>			
Number of Axles	—	1	1
Capacity - Axle Rating	lbs (kg)	2200 (988)	220 (998)
Tire Size	in	13	13
Hitch—Standard	—	2" Ball	2" Ball
Maximum Tire Pressure	psi	50	50
<i>Specifications are subject to change without notice.</i>			

DESCRIPTION	UNITS	MLT4080KV
<b>Engine</b>		
Make/Brand	—	KUBOTA
Model	—	D1105-E3BG
EPA Tier	—	4F
Type	—	Diesel, liquid cooled, 4-stroke
Horsepower - prime	hp (kW)	13.5 (10.1)
Horsepower - standby	hp (kW)	15.4 (11.5)
Operating Speed	rpm	1800
Displacement	in <sup>3</sup> (L)	68.53 (1.12)
Cylinders	qty	3
Fuel Consumption—100% Prime	gph (Lph)	0.70 (2.65)
Battery Type—Group Number	—	24
Battery Voltage	quantity per unit	12V (1)
Battery Rating	CCA-hour	440
<b>Generator</b>		
Make/Brand	—	Marathon Electric
Model	—	201CSA5412
Type, Insulation	—	Brushless, F
Output	kW (kVA)	8.0 (8.0)
Output Voltage	volts	120/240, single phase
Output Amperes <b>120V (240V)</b>	amperes	66 (33)
Frequency Hz	Hertz	60
Power Factor	—	1 (1Ø)
Sound (23 ft at prime)	dB (A)	70
<b>Weights</b>		
Dry Weight	lbs (kg)	1785 (810)
Operating Weight	lbs (kg)	2188 (992)
<b>Capacities</b>		
Fuel Tank Volume	gal (L)	56 (212)
Usable Fuel Volume	gal (L)	56 (212)
Coolant (including engine)	qt (L)	4.8 (4.5)
Oil (including filter)	qt (L)	5.4 (5.1)
Maximum Run Time	hours	80
<b>AC Distribution</b>		
Circuit Breaker Size	amperes	40
Voltage Regulation	—	Capacitor +/-6%
Voltages Available 1Ø	—	120, 240
<b>Lighting</b>		
Lighting Type	—	Metal Halide
Ballast Type	—	Coil & Core
Lumens	—	440,000-462,000
Coverage	acres (m <sup>2</sup> )	5-7 (20,234 - 28,328)
<b>Trailer</b>		
Number of Axles	—	1
Capacity - Axle Rating	lbs (kg)	2200 (988)
Tire Size	in	13
Hitch—Standard	—	2" Ball
Maximum Tire Pressure	psi	50
<i>Specifications are subject to change without notice.</i>		

# Unit Dimensions

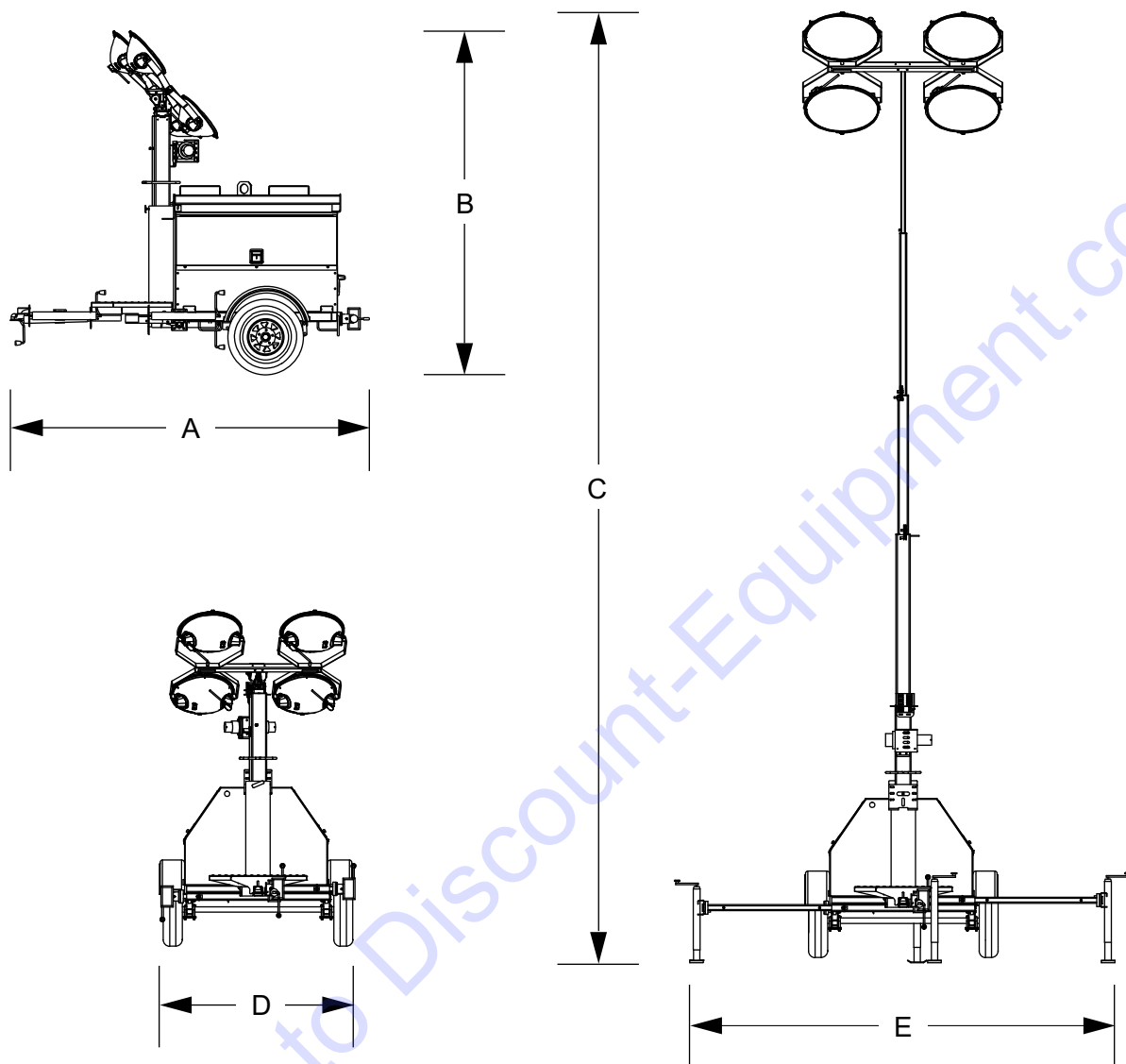

004586

**Figure 2-1. Unit Dimensions**

	<b>A</b>	<b>B</b>	<b>C</b>	<b>D</b>	<b>E</b>
<b>MLT4060MV/KV, MLT4080KV</b>	115 in (2.92 m)	107 in (2.71 m)	25 ft (7.6 m)	68 in (1.73 m)	140 in (3.56 m)

Specifications are subject to change without notice.

## Unit Serial Number Locations

Refer to the illustration to locate the unit ID tag and Vehicle Identification Number (VIN) tag on the unit. Important information, such as the unit serial number, model number, VIN and tire loading information are found on these tags. Record the information from these tags so it is available if the tags are lost or damaged. When ordering parts or requesting assistance, you may be asked to provide this information.

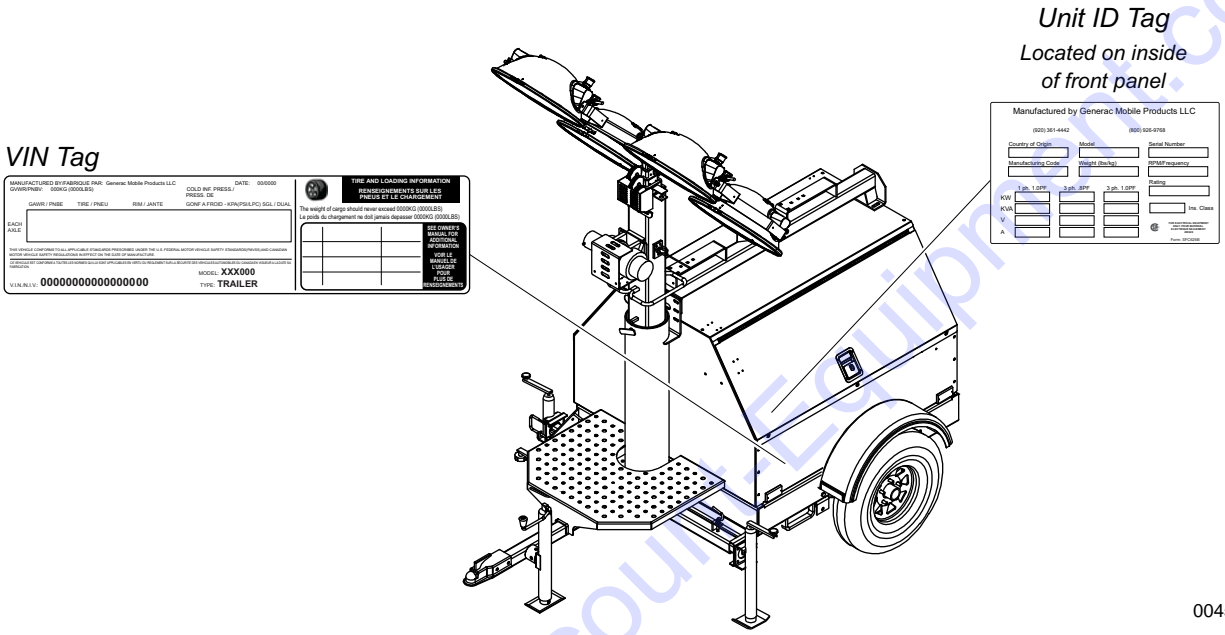
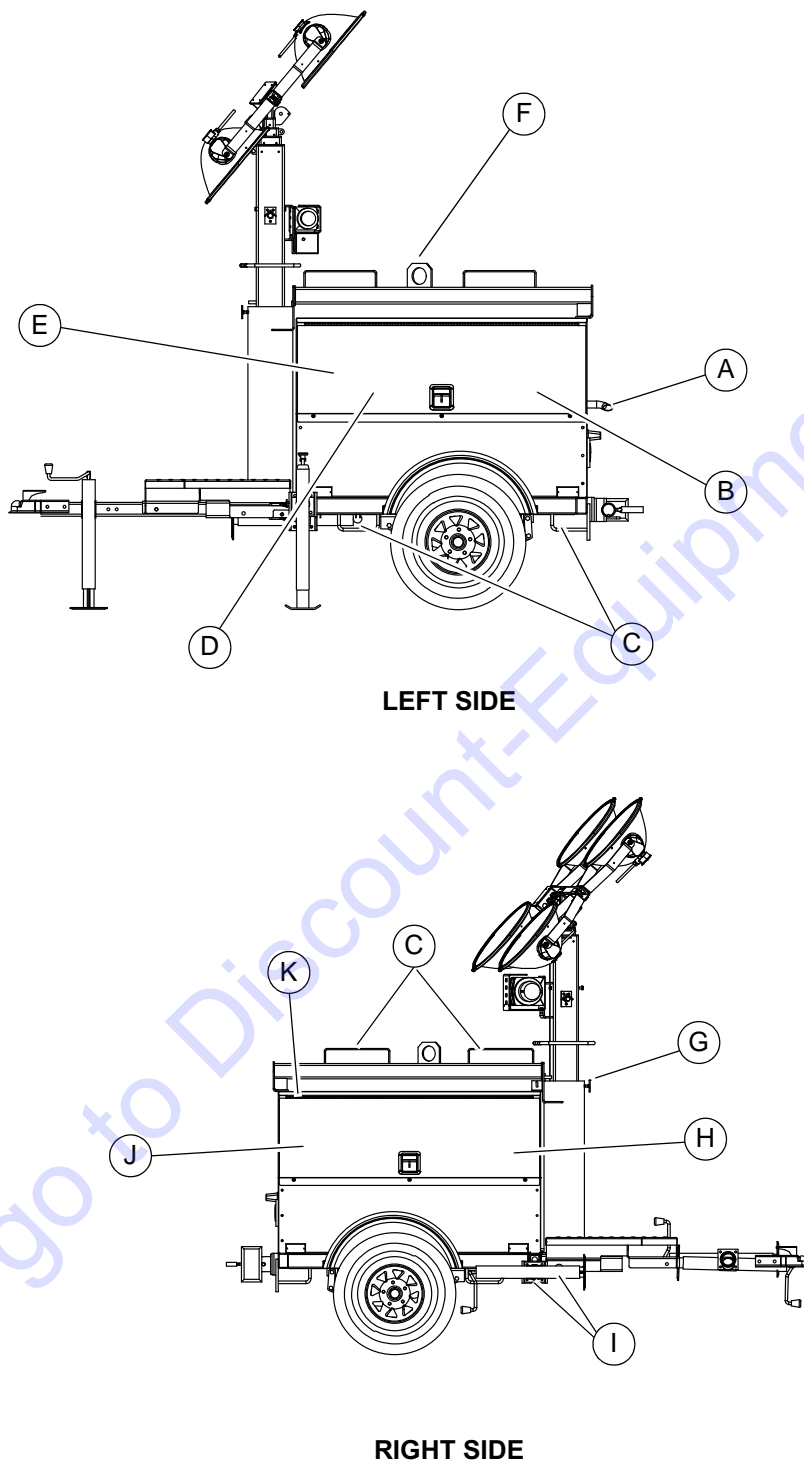

Figure 2-2. Serial Number Locations

004587

# Component Locations



004589

**Figure 2-3. Component Locations**

<b>A</b>	Engine Exhaust	<b>E</b>	Control Box	<b>I</b>	Outriggers
<b>B</b>	Mast Switch	<b>F</b>	Central Lifting Point	<b>J</b>	Engine Access
<b>C</b>	Forklift Pockets	<b>G</b>	Mast Rotation Knob	<b>K</b>	Radiator Access
<b>D</b>	Battery	<b>H</b>	Fuel Fill	—	—



# Control Panel - MLT4060MV, MLT4060KV

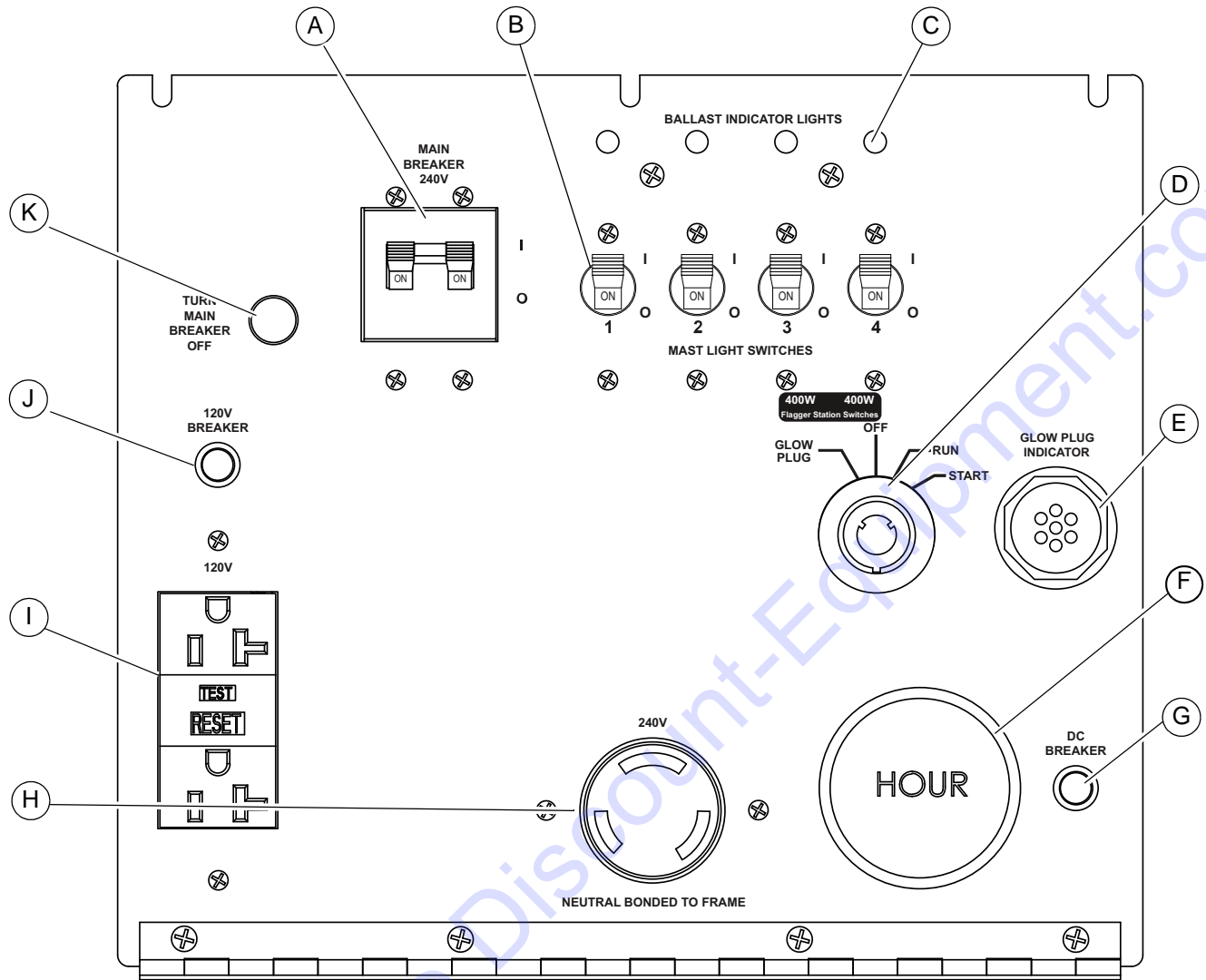

004548

Figure 2-4. Control Panel

## Control Panel Features and Functions

### (A) Main Circuit Breaker

This 240V (30A) breaker will disconnect power to the lights and auxiliary outlets. It will also disable the starting circuit if engine starting is attempted when the main breaker is on.

### (B) Light Switches

One circuit breaker is supplied for each light.

### (C) Ballast Indicator Lights

Indicates power from the ballast to each light.

### (D) Engine Starting Switch

Keyed switch operates glow plugs, starts and stops engine.

### (E) Glow Plug Indicator

Indicates operation of the engine glow plugs (Mitsubishi engines only).

### (F) Engine Hour Meter

Keeps track of engine hours for service.

### (G) DC Circuit Breaker

Circuit breaker (10A) for the engine electrical system.

### (H) 240V Twist-Lock Outlet

This 240V (30A) outlet supplies power for accessories connected to the generator when the engine is running and the main circuit breaker is switched to the ON (I) position.

### (I) 120V GFCI Outlets

This unit is equipped with one 120V (20A) GFCI outlet to supply power for accessories connected to the generator when the engine is running and the main circuit breaker is switched ON (I).

### (J) 120V Breaker

This 120V (20A) circuit breaker is supplied for the 120V GFCI duplex outlets.

### (K) Circuit Breaker Indicator Light

This light indicates that the main circuit breaker must be opened (switched off) before starting the engine.

# Control Panel - MLT4080KV

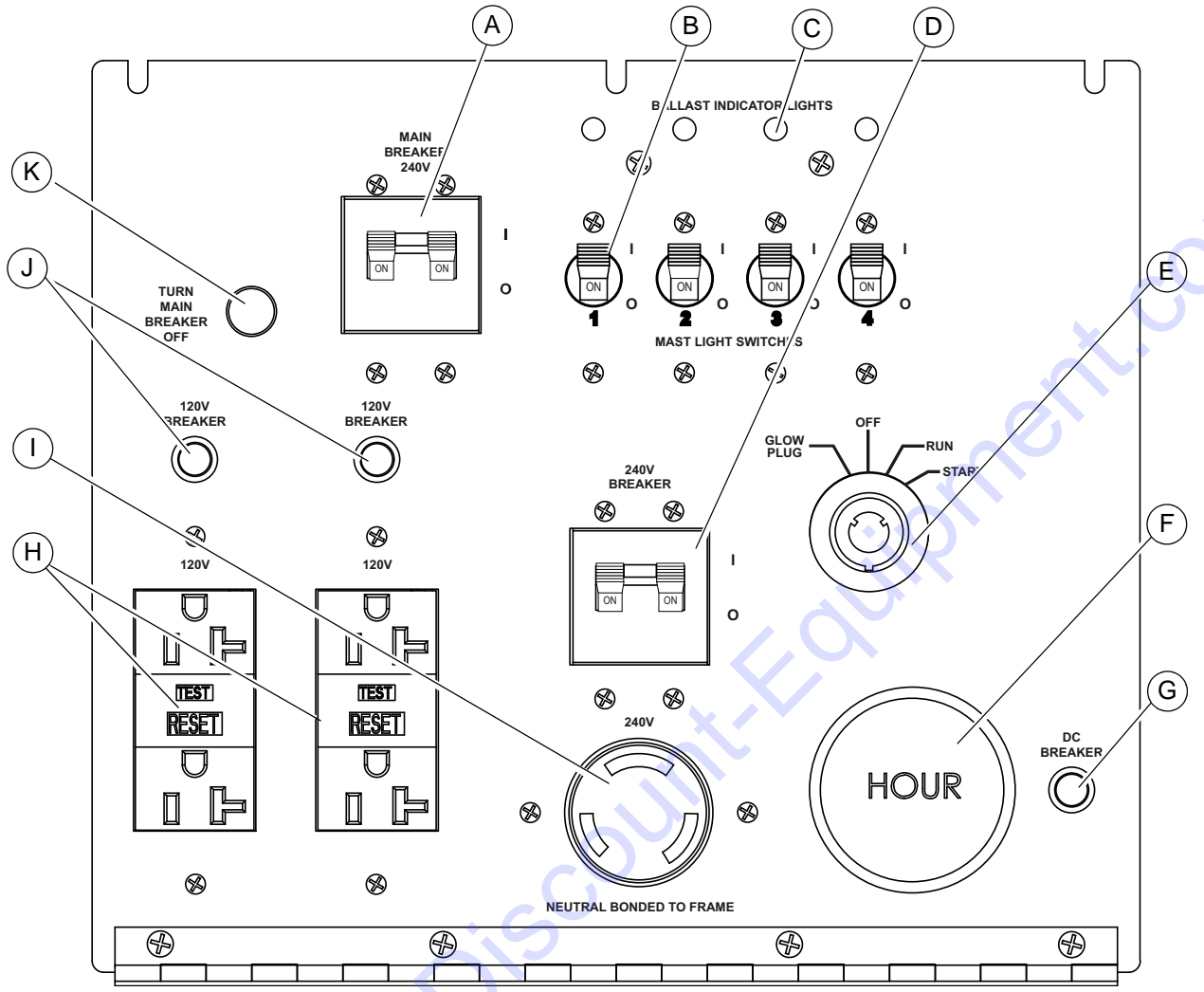

004554

Figure 2-5. Control Panel

## Control Panel Features and Functions

### (A) Main Circuit Breaker

This 240V (30A) breaker will disconnect power to the lights and auxiliary outlets. It will also disable the starting circuit if engine starting is attempted when the main breaker is on.

### (B) Light Switches

One circuit breaker is supplied for each light.

### (C) Ballast Indicator Lights

Indicates power from the ballast to each light.

### (D) 240V Breaker

This 240V (30A) circuit breaker is supplied for the 240V twist-lock receptacle.

### (E) Engine Starting Switch

Keyed switch operates glow plugs, starts and stops engine.

### (F) Engine Hour Meter

Keeps track of engine hours for service.

### (G) DC Circuit Breaker

Circuit breaker (10A) for the engine electrical system.

### (H) 120V GFCI Outlets

This unit is equipped with one 120V (20A) GFCI outlet to supply power for accessories connected to the generator when the engine is running and the main circuit breaker is switched ON (I).

### (I) 240V Twist-Lock Outlet

This 240V (30A) outlet supplies power for accessories connected to the generator when the engine is running and the main circuit breaker is switched to the ON (I) position.

### (J) 120V Breaker

This 120V (20A) circuit breaker is supplied for the 120V GFCI duplex outlets.

### (K) Circuit Breaker Indicator Light

This light indicates that the main circuit breaker must be opened (switched off) before starting the engine.

**This page intentionally left blank.**

To order go to [DiscountEquipment.com](http://DiscountEquipment.com)

# Section 3: Operation

## Light Tower Setup

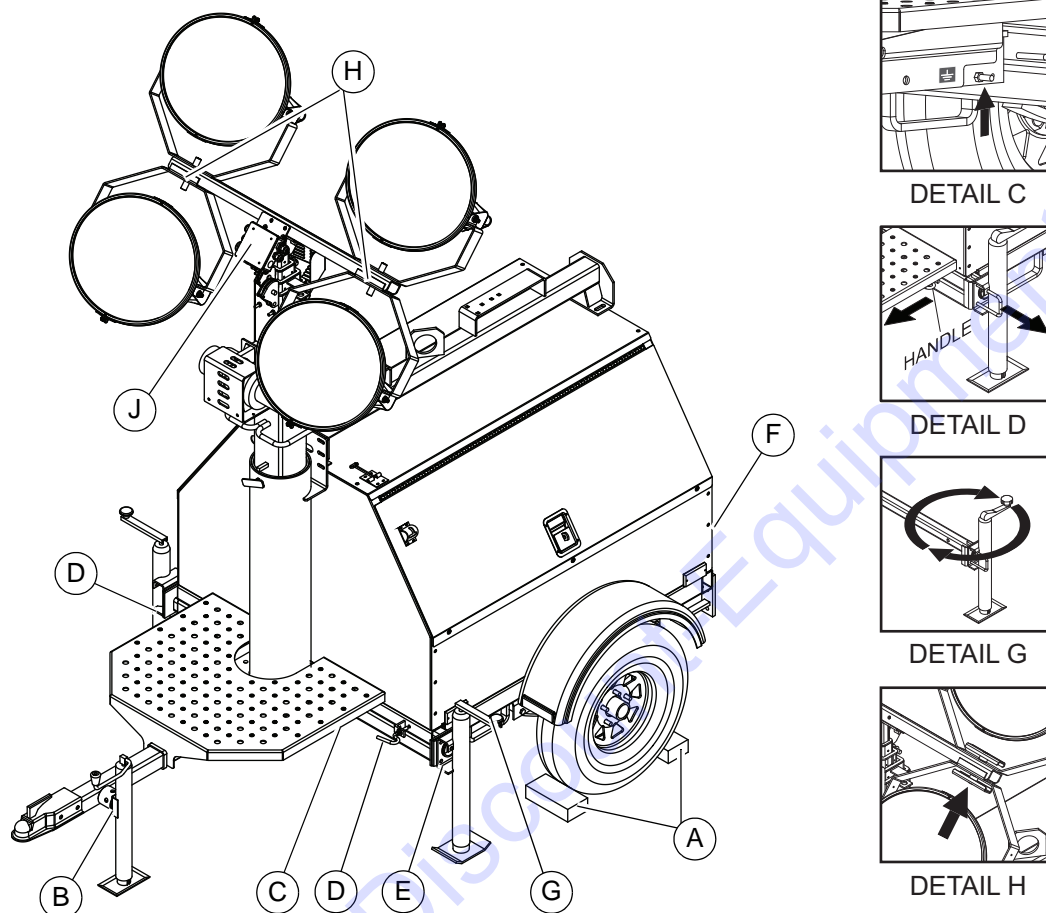

Figure 3-1. Set Up Outriggers and Jacks

004591



**⚠ DANGER**

High Voltage. Verify area above unit is clear of overhead wires and obstructions. Contact with high-voltage power lines will result in death or serious injury. (000260a)



> 60 mph

**⚠ WARNING**

Do not set up the unit if high winds are expected. High winds can cause the unit to tip or fall, causing severe injury or machine damage. (000297)

1. For maximum light coverage, position the unit at ground level or in a spot higher than the area being illuminated by the lamps.

**NOTE:** The mast extends up to 25 ft (7.4 m).

2. See **Figure 3-1**. Place the unit on firm ground that is relatively flat (less than 5° slope), and then block the wheels to keep it from moving (A). This will make it easier to level the unit.
3. Pull the locking pin on the tongue jack (B) and rotate the jack 90°. Install the locking pin. Rotate the jack handle clockwise to raise the trailer tongue off the towing vehicle.
4. A grounding stud (C) is located on the frame of the trailer near the trailer tongue. For grounding requirements, follow the National Electrical Code (NEC), state, and local regulations.
5. Pull the locking pins (D) on the outriggers (E) and pull each outrigger out until the spring loaded locking pin snaps back into place. Pull the locking pin on each outrigger jack and rotate each jack 90° so the jack pad is facing down and the spring loaded locking pin snaps back into place.
6. Pull the locking pin on the rear jack (F) and rotate it 90° until the spring loaded pin snaps back into

place. Turn the jack handle clockwise to start leveling the trailer.

7. Rotate each jack handle clockwise to start leveling the trailer. Adjust all four jacks by rotating their handles clockwise until they are firmly in contact with the ground (G).
8. Before raising the mast, it may be necessary to adjust the lamps. The lamps may be adjusted up, down, left or right by loosening the wing nuts on the trunnion (H) and aiming the lamps in the desired direction. Tighten the hardware completely and make sure the lamps are connected to the junction box (J).

## Prestart Checklist

Before starting the unit, all items in the prestart checklist must be completed. This checklist applies to both manual and remote starting of the unit.



### ⚠ WARNING

Consult Manual. Read and understand manual completely before using product. Failure to completely understand manual and product could result in death or serious injury. (000100a)

- Verify all maintenance procedures are up to date. For more information, refer to **General Maintenance** and **Basic Maintenance Schedule**.
- The unit must be level.
- The unit must be dry. Look for water inside or near the unit; dry if needed.
- For grounding requirements, follow the National Electrical Code (NEC), state, and local.
- Verify the Control Power switch is in the OFF (O) position.
- Verify all circuit breakers are in the OFF (O) position.
- Inspect all electrical cords; repair or replace any that are cut, worn, or bare.
- Verify all winch cables are in good condition and centered on each pulley. Do not use if cables are kinked or beginning to unravel.
- Check oil, coolant, and fuel levels. For more information, refer to **General Maintenance**.
- Verify battery connections are secure.
- Turn the battery disconnect switch on, if equipped.
- Check the engine fan belt tension and condition.
- Check the engine fan belt guard.
- Check the engine exhaust system for loose or rusted components.
- Verify all covers are in place and secure.

## Raising the Mast

1. Set up and level the unit. See **Light Tower Setup**.



### ⚠ DANGER

Electrocution. DO NOT use the unit if electrical cord is cut or worn through. Doing so will result in death or serious injury.

(000263a)

### ⚠ WARNING

Tipping hazard. Extend the outriggers and level the unit before raising the mast. Keep the outriggers extended while the mast is up. Failure to do so could cause the unit to tip and fall and could result in death or serious injury.

(000266)

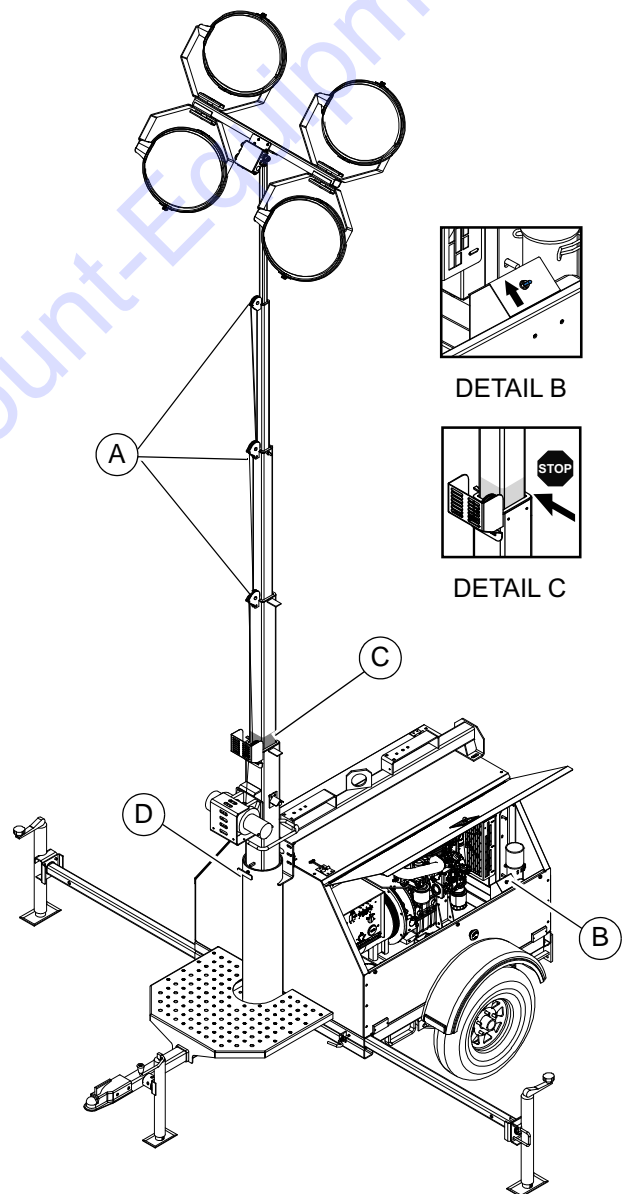

Figure 3-2. Raising the Mast

2. See **Figure 3-2**. Check both sets of mast cables for excessive wear or damage. Verify the cables are properly centered in each pulley (A). Check the electrical cord for damage.
3. Press and hold the winch control toggle switch (B) upward to telescope the mast to the desired height. Extend the mast slowly, verifying the coiled electrical cord is extending at the top sections of the mast.

**IMPORTANT NOTE: Contact a Generac Mobile Products Authorized Service Dealer immediately if the mast hangs up or the winch cable develops slack.**

4. The mast can be rotated by loosening the mast rotation knob at the bottom of the mast (D). Turn the mast until the lights face in the desired direction and then tighten the knob.

**WARNING**

Tipping hazard. Do not extend the mast beyond the colored mark on the second mast section. The unit can become unstable and tip or fall, causing injury.

(000262)

**WARNING**

Personal Injury. Stop immediately if the mast hangs up or the winch cable develops slack. Excess slack could cause the mast to collapse, resulting in personal injury or equipment damage.

(000265)

**WARNING**

Personal injury or equipment damage. Do not raise or lower the mast while the unit is operating. Doing so can break the lenses and cause the lamps to shatter.

(000279)

## Starting the Unit

**NOTE:** If the engine was run out of fuel or the fuel tank was drained, it may be necessary to bleed the fuel lines. Refer to the engine operator's manual supplied with the unit.

1. See **Figure 3-3**. Verify the main circuit breaker and individual circuit breakers for each of the lights are OFF (O).

**WARNING**

Equipment Damage. Never start the engine with circuit breakers switched on. Any load connected to the generator at start up will cause severe damage or destroy the generator.

(000368)

**NOTE:** If the red light on the control panel TURN MAIN BREAKER OFF is illuminated when the key is turned to the START position, the breaker is closed (switched on) and must be turned OFF (O).

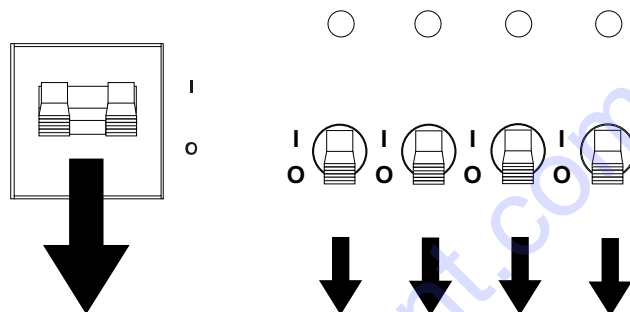

003791

**Figure 3-3. Circuit Breakers in OFF (O) Position**

2. See **Figure 3-4**. Turn the key on the Engine Start switch to the right GLOW PLUG position and hold the key in place for five seconds or until the glow plug indicator turns red. (Kubota units do not have a glow plug indicator.)

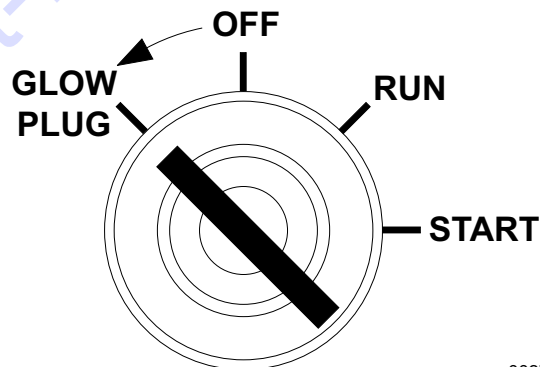

003792

**Figure 3-4. Activate Glow Plug**

3. See **Figure 3-5**. Turn the key to the right START position and hold it until the engine cranks and starts running.

**CAUTION**

Equipment Damage. Do not continuously crank engine for more than ten seconds. Doing so will lead to overdischarge of batteries and starter seizure.

(000230)

**NOTE:** For cold weather conditions, refer to the engine operator's manual for appropriate glow plug interval.

**NOTE:** If oil pressure is not obtained within 15 seconds after the key is switched to the RUN position, the low oil automatic shutdown will turn off the fuel supply, stopping the engine. Check the oil level and turn the key to the



OFF position to reset the oil pressure timer before attempting to restart the engine.

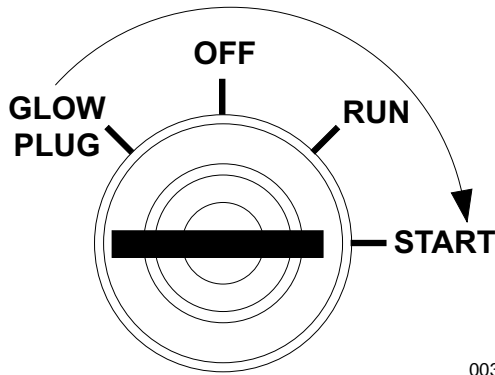

Figure 3-5. Crank Engine

003793

- See [Figure 3-6](#). Release the key, it will move to the RUN position.

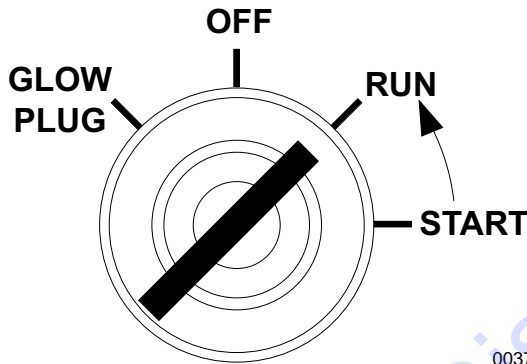

Figure 3-6. Release Key

003794

- Once the engine is running, allow it to reach normal operating temperature before switching on any loads.

## Automatic Shutdown

This unit is equipped with a low oil pressure and high coolant temperature automatic shutdown system. This system will automatically shut off the fuel supply to stop the engine if oil pressure drops too low or the engine exceeds normal operating temperature. Return the main circuit breaker to the OFF (O) position to reset the unit after the cause of shutdown has been determined.

## Light Operation



### WARNING

Burn hazard. Never operate lights with a damaged or missing lens cover. Lamps are hot and pressurized while in use. Unprotected lamps can shatter, causing severe injury.

(000277)

- Verify the unit is on and running smoothly.
- See [Figure 3-7](#). Switch the main circuit breaker (A) ON (I).
- Switch the individual circuit breakers for the lights (B) to the ON (I) position, one at a time.
- The ballast indicator lights (C) will turn on and continue to get brighter as the lights warm up, and then remain on. This confirms power is coming from the ballasts to the lights.

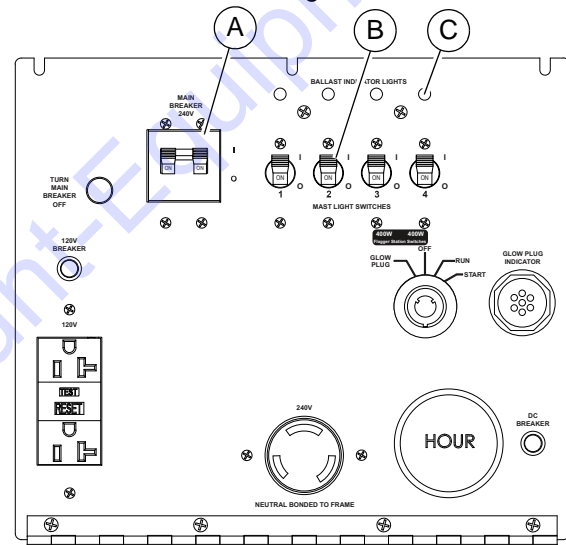

004548

Figure 3-7. Light Switches and Breaker

**NOTE:** If an indicator light does not turn on, see [Troubleshooting](#) or contact a Generac Mobile Products Authorized Service Dealer.

**NOTE:** The lights require a warm up period of 5-15 minutes before they reach full output. If the lights are shut down, they require a cool down period of approximately ten minutes before they can be switched on again.

**NOTE:** The light tower uses four 1000W or 1050W bulbs. When checking or replacing the bulbs, wipe them with a clean cloth to avoid leaving any grease, oil residue or fingerprints on the glass. Any residue can create a hot spot on the bulb, causing premature bulb failure.



**WARNING**

Burn hazard. Lamps become extremely hot while in use. Allow 10–15 minutes for cooling before handling or lowering mast. Touching a hot lens or fixture can cause severe burns.

(000278)

## Voltage Regulation Option

Some units may be equipped with an electronic voltage regulator. The voltage regulator controls the output of the generator by regulating the current into the exciter field. The voltage regulator is adjusted before shipment from the factory. Contact Generac Mobile Products LLC for additional information before attempting to adjust the voltage regulator.

## Auxiliary Outlets

See [Figure 3-8](#). Depending upon the model, the control panel is equipped one or two 120V GFCI (A) and 240V twist-lock (B) outlets for running accessories or tools from the generator. Power is supplied to the receptacles any time the engine is running and the main circuit breaker is switched ON (I).

**NOTE:** Do not pull more than 1000W from each outlet when the lights are on. This will overload the generator and cause the main circuit breaker to trip. Should the breaker trip, switch off the lights, remove some of the load to the outlets and wait 10 minutes for the bulbs to cool before turning them back on.

With all of the lights off, the full generator output may be used with the 240V twist-lock outlet.

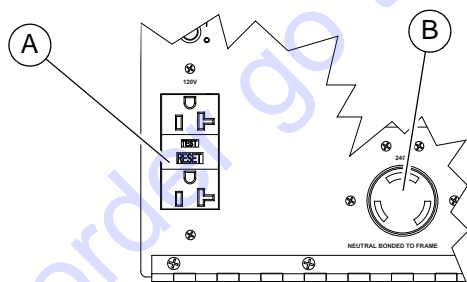

004478

**Figure 3-8. Auxiliary Outlets**

exhaust system. Wet stacking can be detected by continuous black exhaust when the unit is under a constant load. It can also cause fouling of injectors and buildup on engine valves. Diesel engines operate properly when applied loads are between 30% and 100% capacity. Appropriate generator sizing is determined by the anticipated load. If the unit is in a wet stack condition, load the unit heavily for five hours or until the exhaust is clear.

## Engine Derating

All units are subject to derating for altitude and temperature. Derating reduces the available power for operating tools and accessories connected to the outlets. For every increase in 1000 ft (305 m) of elevation, engine performance for this unit typically drops between 2% and 4%. Also, engine performance decreases about 1% for every 10°F (5.6°C) increase in ambient air temperature over 72°F (22°C).

## Shutting Down the Unit

Check with personnel using power supplied by the unit and let them know the power is going to be turned off. Make sure the power shutdown will not create any hazards by accidentally turning off equipment that needs to remain running (pumps, compressors, lights, etc.).

1. Remove all loads from the outlets.
2. See [Figure 3-9](#). Switch the individual circuit breakers for each light OFF (O).
3. Switch the main circuit breaker OFF (O).
4. Move the control power switch to STOP.

**NOTE:** For extended storage time, disconnect the battery. For extended storage requirements, refer to the engine operator's manual.

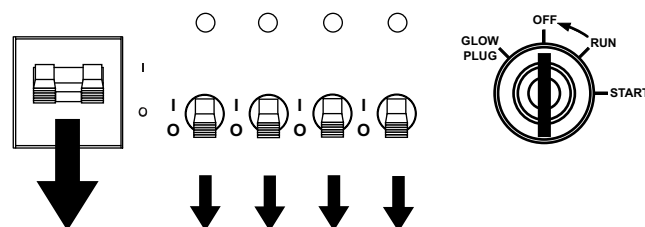

004550

**Figure 3-9. Shutting Down**

## Wet Stacking

The unit is powered by a diesel engine. Diesel engines are susceptible to wet stacking if lightly loaded. Wet stacking occurs when an engine is run at less than 30% of its full load capacity, causing unburned fuel to accumulate in the

**TO PURCHASE THIS PRODUCT PLEASE CONTACT US**



**Equipment Financing and  
Extended Warranties Available**



**Discount-Equipment.com is your online resource for  
commercial and industrial quality parts and equipment sales.**

**561-964-4949**

**visit us on line @ [www.discount-equipment.com](http://www.discount-equipment.com)**

Select an option below to find your Equipment

**Search by Manufacturer**

**Search by Product Type**

**Request a Quote**

We sell worldwide for the brands: Genie, Terex, JLG, MultiQuip, Mikasa, Essick, Whiteman, Mayco, Toro Stone, Diamond Products, Generac Magnum, Airman, Haulotte, Barreto, Power Blanket, Nifty Lift, Atlas Copco, Chicago Pneumatic, Allmand, Miller Curber, Skyjack, Lull, Skytrak, Tsurumi, Husquvarna Target, Stow, Wacker, Sakai, Mi-T-M, Sullair, Basic, Dynapac, MBW, Weber, Bartell, Bennar Newman, Haulotte, Ditch Runner, Menegotti, Morrison, Contec, Buddy, Crown, Edco, Wyco, Bomag, Laymor, EZ Trench, Bil-Jax, F.S. Curtis, Gehl Pavers, Heli, Honda, ICS/PowerGrit, IHI, Partner, Imer, Clipper, MMD, Koshin, Rice, CH&E, General Equipment, Amida, Coleman, NAC, Gradall, Square Shooter, Kent, Stanley, Tamco, Toku, Hatz, Kohler, Robin, Wisconsin, Northrock, Oztec, Toker TK, Rol-Air, APT, Wylie, Ingersoll Rand / Doosan, Innovatech, Con X, Ammann, Mecalac, Makinex, Smith Surface Prep, Small Line, Wanco, Yanmar

## Lowering the Mast



### ⚠️ WARNING

Burn hazard. Lamps become extremely hot while in use. Allow 10–15 minutes for cooling before handling or lowering mast. Touching a hot lens or fixture can cause severe burns.

(000278)

1. Shut down the lights and engine. See [Shutting Down the Unit](#).
2. If the trailer is going to be moved, it is recommended that the mast is turned so the lights face toward the back of the unit. To rotate the mast:
  - a. Loosen the mast rotation knob.
  - b. Rotate the mast until the white arrows are aligned and the metal stop tabs are touching. The winch and lights should be facing toward the back of the unit.
  - c. Tighten the mast rotation knob.
3. Press and hold the winch control toggle switch downward to collapse the mast to its lowest position. Verify the electrical cord does not get caught in, or pinched by, the mast while it is being lowered.

### ⚠️ WARNING

Personal Injury. Stop immediately if the mast hangs up or the winch cable develops slack. Excess slack could cause the mast to collapse, resulting in personal injury or equipment damage.

(000265)

**IMPORTANT NOTE:** Contact a Generac Mobile Products Authorized Service Dealer immediately if the mast hangs up or the winch cable develops slack.

**NOTE:** If the generator is not operational, and the batteries do not have enough power to lower the mast, it may be necessary to lower the mast manually.

**NOTE:** Generac Mobile Products strongly recommends that the lights be removed from the mast and stowed for transportation. See [Towing the Unit](#).

### Lowering the Mast—Manually



### ⚠️ WARNING

Burn hazard. Lamps become extremely hot while in use. Allow 10–15 minutes for cooling before handling or lowering mast. Touching a hot lens or fixture can cause severe burns.

(000278)

**NOTE:** Do not use this procedure unless it is absolutely necessary. Continuous use of this procedure could damage the planetary gear brake of the winch. This

procedure will not work if the planetary gear brake is damaged.

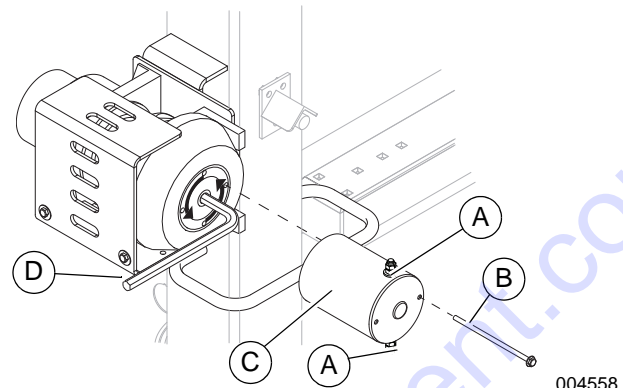

**Figure 3-10. Winch Assembly**

1. See [Figure 3-10](#). Remove the power cables from the two terminals on the winch motor assembly (A).
2. Remove the two flange head screws (B) securing the winch motor assembly to the winch. Retain the screws for reassembly.
3. Carefully remove the motor assembly (C), making sure the two pieces do not separate.
4. Insert a 3/8" allen head wrench (D) into the sleeve bearing.
5. Rotate the wrench counter-clockwise to lower the mast. If any slack is observed in the cable, stop immediately and remove the slack.
6. When the mast is completely down, reinstall the winch motor assembly, securing it with the screws.

## Towing the Unit

Once the engine is shut down and the mast and lights are properly stowed, follow these steps to prepare the unit for towing.

1. Raise the rear jack completely and release the locking pin to rotate it up into the travel position. Verify the locking pin snaps into place.
2. Raise the outrigger jacks completely and release the jack locking pin to swing the jacks up into the travel position. Verify the locking pins snap into place. Release the outrigger locking pins and slide the outriggers into the trailer frame until the locking pins snap into place.
3. Use the tongue jack to raise or lower the trailer onto the hitch of the towing vehicle. Lock the hitch coupling and attach the safety chains or cables to the vehicle. Remove the jack locking pin and rotate the jack into the travel position. Replace the locking pin.

**NOTE:** A film of grease on the coupler will extend coupler life and eliminate squeaking. Wipe the coupler clean and apply fresh grease each time the unit is towed.

4. To ensure proper operation of the jacks, lubricate the grease fittings located on the leveling jacks. Refer to **Jack Maintenance**. For maintenance interval information, refer to **Basic Maintenance Schedule**.
  5. Connect any trailer wiring to the tow vehicle. Check for proper operation of the directional and brake lights.
  6. Verify the cradle locking pin is in place.
  7. Verify the doors and enclosure are properly latched.
  8. If driving over rough ground, remove the bulbs from the light fixtures.
  9. Check for proper inflation of the trailer tires. For maximum tire pressures, refer to **Specifications**.
  10. See **Figure 3-11**. Check the wheel lugs. Tighten or replace any lugs that are loose or missing. If a tire has been removed for axle service or replaced, tighten the lugs, in the order shown, to the following specifications:
3. Verify the cradle locking pin is in place.
  4. When lifting the light tower and trailer, attach any slings, chains or hooks directly to the central lifting eye (A).
  5. Always remain aware of people and objects around the unit while preparing, maneuvering, and lifting the unit.
  6. Use the upper (B) or lower (C) forklift pockets with care. Approach the unit as perpendicular as possible to avoid any damage to the unit. Verify the mast winch handles or any other obstructions are clear of the forklift tines before lifting.

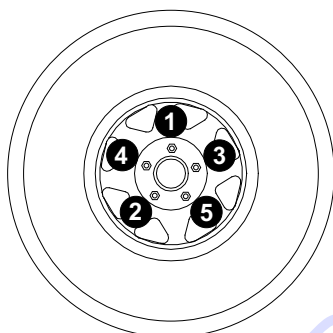

003754

**Figure 3-11. Tightening Wheel Lugs**

- a. Start all lug nuts by hand.
- b. First pass: tighten to 20-25 ft-lbs (27-33 Nm).
- c. Second pass: tighten to 50-60 ft-lbs (67-81 Nm).
- d. Third pass: tighten to 90-120 ft-lbs (122-162 Nm).

**NOTE:** After the first road use, re-torque the lug nuts in sequence.

11. Maximum recommended speed for highway towing is 45 mph (72 km/h). Recommended off-road towing speed is not to exceed 10 mph (16 km/h) or less, depending on the terrain.

## Lifting the Unit

Follow these steps to prepare the unit for lifting:

1. Verify the equipment being used to lift the unit is in good condition and has sufficient capacity. For approximate weights, refer to **Specifications**.
2. See **Figure 3-12**. Close and lock all hoods and doors and stow the lights as shown.

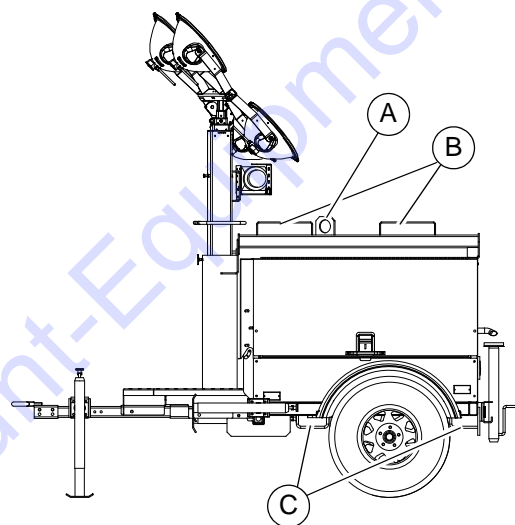

**Figure 3-12. Lifting Point**

004511

**This page intentionally left blank.**

To order go to [Discount-Equipment.com](http://Discount-Equipment.com)

## Section 4: Maintenance

### Emissions Information

For warranty information, please refer to the diesel engine manual supplied with this unit.

### Daily Walk-Around Inspection

Perform a walk-around inspection of the unit every day before starting the unit. Look for conditions that could hinder performance or safety, such as (but not limited to):

- Oil, coolant and fuel leakage
- Blocked vents
- Loose or missing hardware
- Loose or broken electrical connections.

Inspect the fan belt for cracks, fraying, or stretching. Verify the belt is properly seated in the pulley grooves. Replace the belt according to the manufacturer's recommendations.



Equipment Damage. Failure to perform a daily inspection could result in damage to the unit.

(000306)

### General Maintenance

Poorly maintained equipment can become a safety hazard. In order for the equipment to operate safely and properly over a long period of time, periodic maintenance and occasional repairs are necessary. **DO NOT** perform routine service (oil and filter changes, cleaning, etc.) unless all electrical components are shut off.

Regular maintenance will improve performance and extend engine/equipment life. Generac Mobile Products LLC recommends that all maintenance work be performed by a Generac Mobile Products Authorized Service Dealer. Regular maintenance, replacement or repair of the emissions control devices and systems may be performed by any repair shop or person of the owner's choosing. However, to obtain emissions control warranty service free of charge, the work must be performed by a Generac Mobile Products Authorized Service Dealer or authorized engine dealer depending on the repair. See the emissions warranty.

### Preparing for Service

Before servicing the unit, always follow the instructions listed below.

1. Verify the Control Power switch is in the OFF (O) position.
2. Verify the circuit breakers are switched OFF (O).

3. Disconnect the negative (–) terminal on the battery.
4. Attach a "Do Not Start" sign to the control panel. This will notify everyone that the unit is being serviced and will reduce the chance of someone inadvertently trying to start the unit.

### Cleaning the Unit

Always clean the Light Tower after each use to remove dust, grease, mud, or spilled fuel or oil. Use soft, clean rags to wipe the cabinet exterior and control panel. Low-pressure compressed air (less than 40 PSI [276 kPa]) can also be used to remove dust and debris from the cabinet interior.

This unit contains sensitive electronic components that can be damaged by high pressure and heat. Therefore:

- Do not wash the unit with a high pressure hose or power washer.
- Do not wash the engine block or fuel tank with a power washer or steam cleaner. Water may enter the cabinet and collect in the generator windings or other electrical parts, causing damage.

### Inspecting the Unit

- If the unit is stored outside, check for water inside the cabinet and generator before each use. If wet, dry the unit thoroughly before starting.
- Inspect condition of electrical cords. **DO NOT** use the unit if insulation is cut or worn through.
- Verify winch cables are in good condition and centered on each pulley. **DO NOT** use a cable that is kinked or starting to unravel.
- See [Figure 4-1](#). Verify proper mast cable routing.

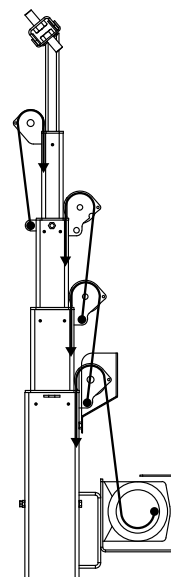

004559

**Figure 4-1. Proper Mast Cable Routing**

- Verify the safety pins for the mast lock rod and mast lock bar are present and secured with a chain. Check that the spring located in the mast lock bar is not broken or missing. Check the operation of the mast lock bar.
- Verify the wheel lugs are present and properly tightened. Refer to **Towing Safety**.
- Check the coolant level daily by inspecting the level in coolant overflow jug located near the radiator. Refer to the engine operator's manual for coolant recommendations and proper mixture. Normal operating level is between the 'full' and 'add' markings on the overflow jug.
- **AFTER ENGINE IS STOPPED AND COMPLETELY COOL**, coolant may be added directly to the coolant overflow jug.
- Check the oil level daily. Refer to the engine operator's manual for the appropriate oil specification. Verify the oil is correct for special operating conditions such as a change in season or climate.
- **DO NOT** start the unit if the engine oil level is below the add mark on the dipstick.
- Normal operating level is in the cross-hatch pattern between the full and add markings on the dipstick.
- Add oil only if the oil level is below the add mark on the bottom of the cross-hatch pattern on the dipstick. **DO NOT OVERFILL** the crankcase.
- Check the fuel level.
- If the unit is connected to a remote start or transfer switch, make sure the remote switch is also off and tagged.

**NOTE:** If the engine was run out of fuel or the fuel tank was drained, it may be necessary to bleed the fuel lines. Refer to the engine operator's manual supplied with the unit.

## Basic Maintenance Schedule

Refer to the original equipment manufacturer's operating manual for a complete list of maintenance requirements. Failure to comply with the procedures as described in the engine operator's manual will nullify the warranty, decrease performance and cause equipment damage or premature equipment failure. Maintenance records may be required to complete a warranty request.

Use the schedule in the following table as a guide for regular maintenance intervals. For additional or replacement copies of the engine operator's manual, contact a Generac Mobile Products Authorized Service Dealer.



**Table 4-1. Basic Maintenance Guide (Mitsubishi)**

ITEM	DAILY	50 Hours	250 Hours	400 Hours	500 Hours	1000 Hours
Check oil level	◆					
Check coolant level	◆					
Check fuel level	◆					
Check tire pressure	◆					
Check all electrical connections	◆					
Inspect radiator fins for debris, clean as required	◆					
Inspect light tower winch for proper operation	◆					
Fuel tank - drain water		◆				
Check air cleaner		◆				
Replace engine oil and oil filter			◆*			
Belt and belt tension - inspect and adjust			◆			
Replace fuel filter				◆		
Drain and clean fuel tank					◆**	
Check glow plugs					◆	
Lubricate leveling jacks					◆	
Bolts and nuts on the engine - retighten						◆*
Replace heated fuel filter (if equipped)						◆
Inspect engine starting battery						◆

\* Perform after the initial 50 hours of operation, then on the regularly scheduled interval indicated in the schedule above.

\*\* Certain conditions may require the fuel tank to be drained and cleaned more often. When operating in extremely dusty conditions, clean the fuel tank as often as necessary.

Table 4-2. Basic Maintenance Guide (Kubota)

ITEM	DAILY	50 Hours	100 Hours	200 Hours	400 Hours	500 Hours	1 Year
Check oil level	◆						
Check coolant level	◆						
Check fuel level	◆						
Check tire pressure	◆						
Check all electrical connections	◆						
Inspect radiator fins for debris, clean as required	◆						
Inspect light tower winch for proper operation	◆						
Check fuel pipes and clamp bands		◆					
Clean air cleaner element			◆				
Clean fuel filter			◆				
Check fan belt tightness			◆				
Drain water separator			◆				
Check radiator hoses and clamp bands				◆			
Change engine oil				◆*			
Check intake air line				◆			
Replace oil filter cartridge					◆*		
Replace fuel filter cartridge					◆		
Clean water separator					◆		
Lubricate leveling jacks						◆	
Remove sediment in fuel tank						◆	
Replace fan belt						◆	
Replace air filter element							◆**

\* Change the engine oil and oil filter after the initial 50 hours of operation, then at the appropriate interval thereafter.

\*\* Replace the air cleaner element yearly, or after six cleanings, whichever occurs first.

## Winch Use, Operation and Maintenance

- Keep the winch free of dirt, oil, grease, water and other substances.
- Check all mounting bolts and make sure they are tightened to the recommended torque values. Replace any damaged fasteners.
- Periodically check all connections to be sure they are tight and free of corrosion.
- Check the cable for visible damage every time the winch is operated. Examples of damage are: cuts, knots, crushed or frayed portions, and broken strands. Replace cable immediately if damaged. Failure to replace a damaged cable could result in breakage.
- Regularly check the brake for slippage or drift. This is detected visually when winch is under load. If winch drum continues to turn after controls are released, the brake may need to be replaced.

- Periodically clean and grease the brake assembly. This will ensure proper performance and extend the life of the winch. If winch seems to labor or get excessively hot during the lowering of loads, the brake will need to be serviced or replaced.
- Check motor brushes periodically and replace when necessary.

**NOTE:** Only the motor brushes and brake assembly require periodic replacement.

### Winch Mechanical Brake

The mechanical brake generates heat when loads are lowered and the wire cable is powered out. Avoid overheating the mechanical brake.

Whine or chatter associated with a new mechanical brake is normal and typically disappears with use.

Overheating the mechanical brake may result in permanent damage to, or failure of, the brake. Replace any damaged brake components before resuming use of the winch.

Table 4-3. Winch Preventative Maintenance Schedule

Maintenance Activity	After First Operation	Before Each Use	Semi-Annually
Check Fasteners	◆		◆
Check Electrical Connections	◆		◆
Clean And Grease Brake Assembly			◆
Check Motor Brushes			◆
Visually Check Winch And Control	◆	◆	◆

## Optional Lower Radiator Hose Heater Use and Maintenance

The following points should be followed when operating a unit equipped with a lower radiator hose heater.

**IMPORTANT NOTE:** Improper use of the lower radiator hose heater could result in serious personal injury.

- Verify that cooling system is full of a proper mixture of water and engine coolant before each heater use.
- Heater is designed for all-night operation; however, 2-5 hours of heating just prior to starting is usually sufficient for proper engine starting.
- When heater is in operation, unit must be parked in a level position to maintain the proper orientation of the heater.
- Use only an undamaged extension cord, outdoors rated, three-prong grounded 120VAC cord with a minimum amperage rating of 10A. Connect to properly grounded 120VAC, GFCI outlet only.
- Before starting the engine, unplug extension cord from power first; then unplug heater cordset from extension cord.

## Trailer Wheel Bearings

The light tower is equipped with a grease zerk fitting to allow lubrication of the wheel bearings without the need to disassemble the axle hub. To lubricate the axle bearings, remove the small rubber plug on the grease cap, attach a standard grease gun fitting to the grease zerk fitting and pump grease into the fitting until new grease is visible around the nozzle of the grease gun. Use only a high quality grease made specifically for lubrication of wheel bearings. Wipe any excess grease from the hub with a clean cloth and replace the rubber plug when finished. The minimum recommended lubrication is every 12 months or 12,000 miles (19,312 km); more frequent lubrication may be required under extremely dusty or damp operating conditions.

## Jack Maintenance

The following procedures should be performed at least annually: For side-wind models, the internal gearing and bushings of the jack must be kept lubricated.

- Apply a small amount of automotive grease (A) to the internal gearing by removing the jack cover, or if equipped, use a needle nose applicator or standard grease gun on the lubrication point found on the side of the jack near the crank. Rotate the jack handle to distribute the grease evenly.
- A lightweight oil (B) must be applied to the handle unit at both sides of the tube for side-wind models.
- If equipped, the axle bolt and nut assembly of the caster wheel must also be lubricated with the same lightweight oil.
- For top-wind models, apply a lightweight oil to the screw stem.

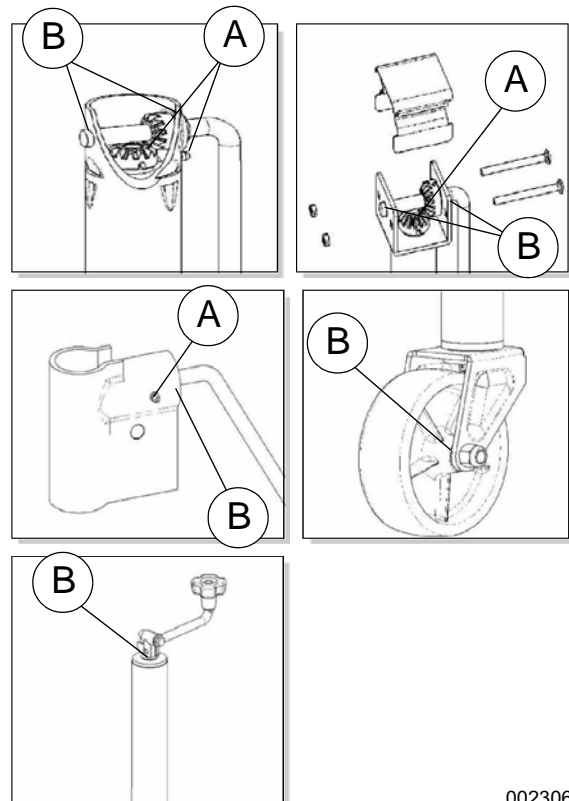

002306

Figure 4-2. Jack Maintenance

**This page intentionally left blank.**

To order go to [DiscountEquipment.com](http://DiscountEquipment.com)

# Section 5: Troubleshooting

## General Troubleshooting

Some of the more common problems are listed in the table below. This information is intended to be a check or verification that simple causes can be located and fixed. It does not cover all types of problems. Refer to the OEM engine operator's manual for additional troubleshooting information. Procedures that require in-depth knowledge or skills should be referred to a Generac Mobile Products Authorized Service Dealer.



**WARNING**

Risk of burns. Allow engine to cool before draining oil or coolant. Failure to do so could result in death or serious injury.

(000139)

**Table 5-1. General Troubleshooting Guide**

Problem	Possible Cause	Solution
Low oil pressure shutdown	Low oil level	Verify oil level on dipstick. Add oil, if needed.
	Oil leaking from engine	Visually inspect the engine for leaks.
	Oil pressure switch failure	Refer to OEM engine operator's manual to identify corrective action.
High coolant temperature shutdown	Low coolant level	Add coolant if needed. Allow engine to cool, then check coolant level in radiator. Restart engine and check coolant temperature. Stop engine immediately if coolant temperature is 210°F (99°C) or more.
	Blockage in radiator	Inspect radiator shroud and ducting for blockage and remove any foreign matter.
	Leakage in coolant hoses, engine block, or water pump	Inspect for visible leaks. Verify tension of water pump serpentine drive belt. Remove load on generator and restart engine. Verify coolant temperature and shut engine down immediately if it starts to overheat. Refer to the OEM engine operator's manual for additional information on engine overheating.
Unit cranks, but will not start	Fuel level low	Check fuel level in tank. Verify fuel pump operation.
	Restricted air filter	Inspect air filter for blockage. Refer to OEM engine operator's manual for additional information.

If problems persist, contact Generac Mobile Products at 1-800-926-9768 for assistance.

## Troubleshooting the Lights



**WARNING**

Burn hazard. Lamps become extremely hot while in use. Allow 10–15 minutes for cooling before handling or lowering mast. Touching a hot lens or fixture can cause severe burns.  
(000278)

**IMPORTANT NOTE:** Only a qualified electrician should troubleshoot or repair electrical problems occurring in this equipment. Contact Generac Mobile Products Technical Service at 1-800-926-9768 for assistance if you have any questions, or if problems persist.



**WARNING**

Electrocution. Potentially lethal voltages are generated by this equipment. Render the equipment safe before attempting repairs or maintenance. Failure to do so could result in death or serious injury.  
(000187)

Problem	Possible Cause	Solution
Mast Lights Off, but Ballast Indicators on Control Panel are On.	Light fixture is too hot. Faulty lamp connection. Lamp broken  Loose lighting connections Damaged or loose electrical cord	Allow light to cool 10-15 minutes before restarting. Check that the lamp is tight in the socket. Check for broken arc tube or outer lamp jacket, broken or loose components in lamp envelope, or blackening/deposits inside tube. Check the connections inside the mast junction box and each mast light housing/socket. Check the mast electrical cord for damage and check the cord connections inside the control box.
Mast Lights Off, and Ballast Indicators on the Control Panel are Off.	Loose lighting connections Generator output incorrect.  Low transformer output.	Check the connections inside the control box and inside each ballast box. Check the incoming voltage to the ballast by checking the available voltage on the GFCI receptacle. Incoming voltage should be 120V +/- 5V. If voltage is incorrect, the engine speed may need to be adjusted or generator may require service. The voltage from the transformer should read approximately 400VAC as the light "strikes" (induces an arc), then drop and slowly rise back up to stabilize at 240-260VAC. On hard wired models, remove the mast junction box cover and insert the wire probes into the connector blocks for the light and ground. If proper voltage is not achieved, perform capacitor check to determine if the capacitor or coil needs to be replaced.
Mast Lights On But the Light Output is Low	Fixture and/or lens is dirty. Lamp worn due to normal use Damaged or loose electrical connections Generator output incorrect.  Low transformer output	Clean reflective surface inside fixture and both inside and outside surface of glass lens. Use mild soap and water to clean lens. Other chemicals may have an adverse effect on the glass. Replace lamp. Check the mast coil cord, mast junction box and mast light connections. Check the incoming voltage to the ballast. Incoming voltage should be 120V +/-5V. If the voltage is incorrect, the engine speed may need to be adjusted or the generator may require service. The voltage from the transformer should read approximately 400VAC as the light "strikes" (induces an arc), then drop and slowly rise back up to stabilize at 240-260VAC. On hard wired models, remove the mast junction box cover and insert the wire probes into the connector blocks for the light and ground. If proper voltage is not achieved, perform capacitor check to determine if the capacitor or coil needs to be replaced.

# Section 6: Wiring Diagrams

## Mast Junction Box Wiring and Light Connections

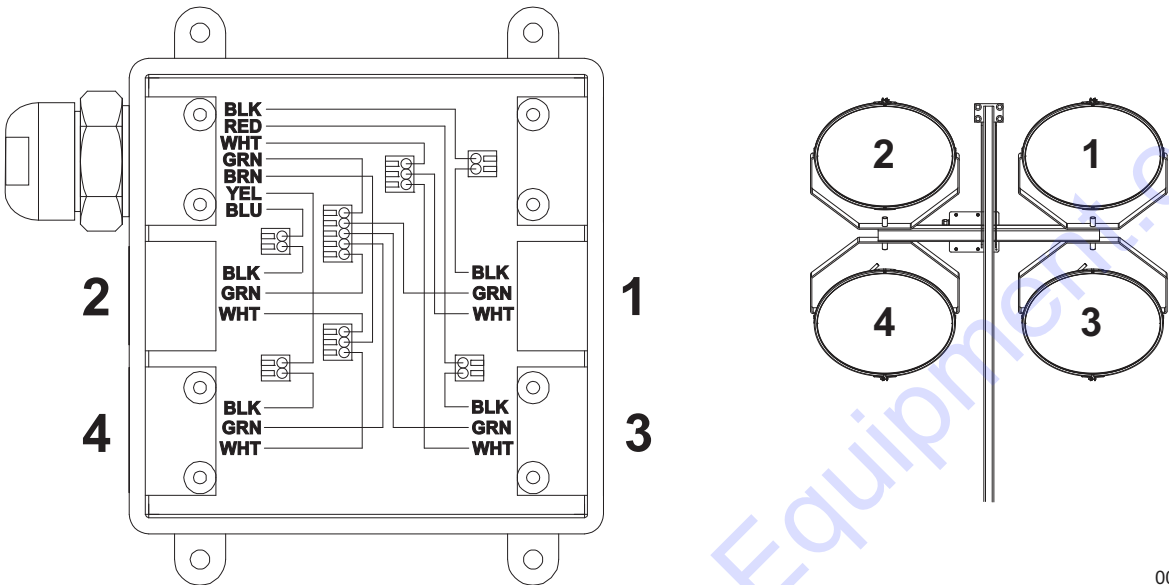

00768

To order go to Discount-Equipment.com

# AC Wiring Diagram

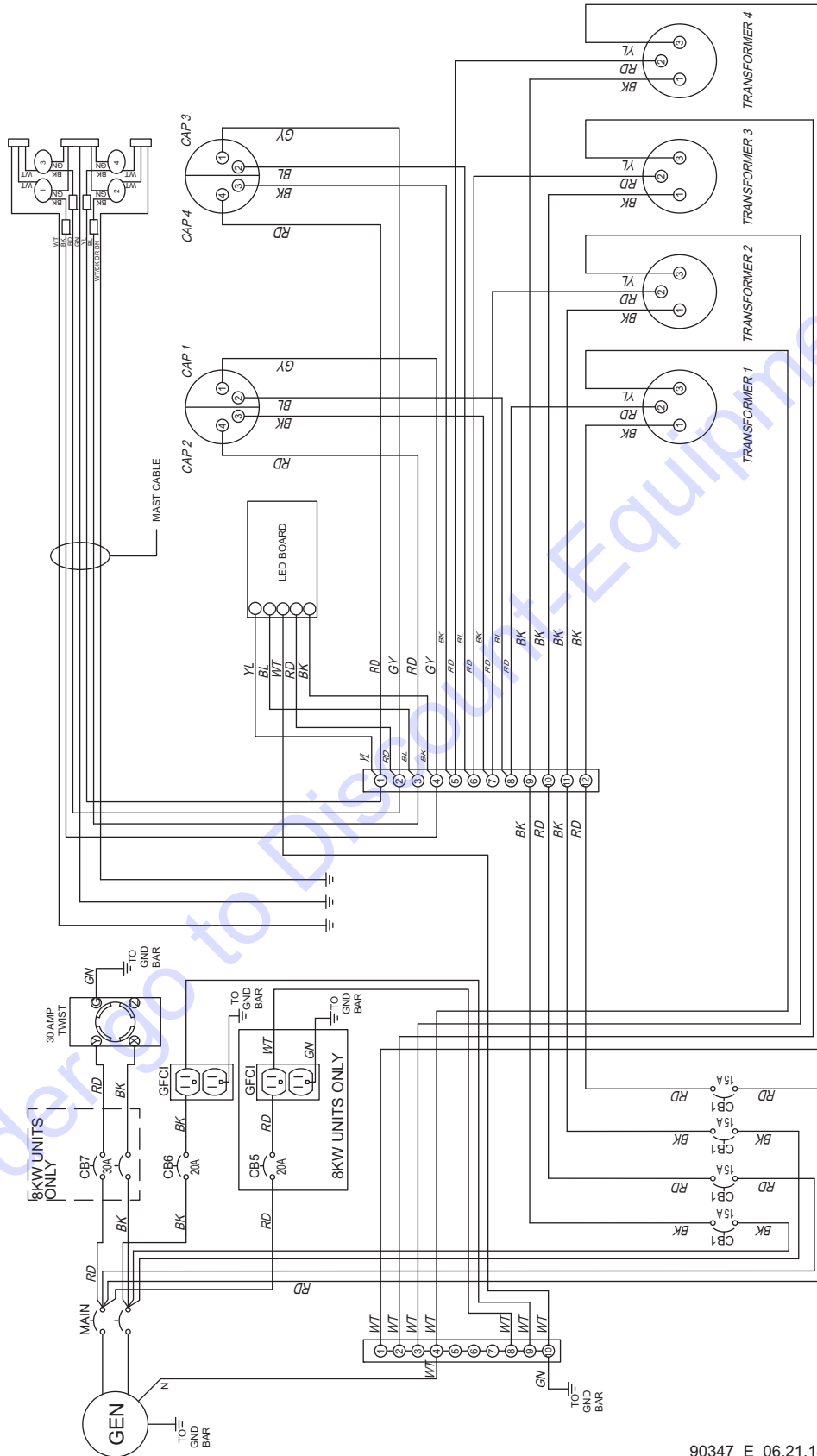

90347\_E\_06.21.14



# DC Wiring Diagram—Mitsubishi

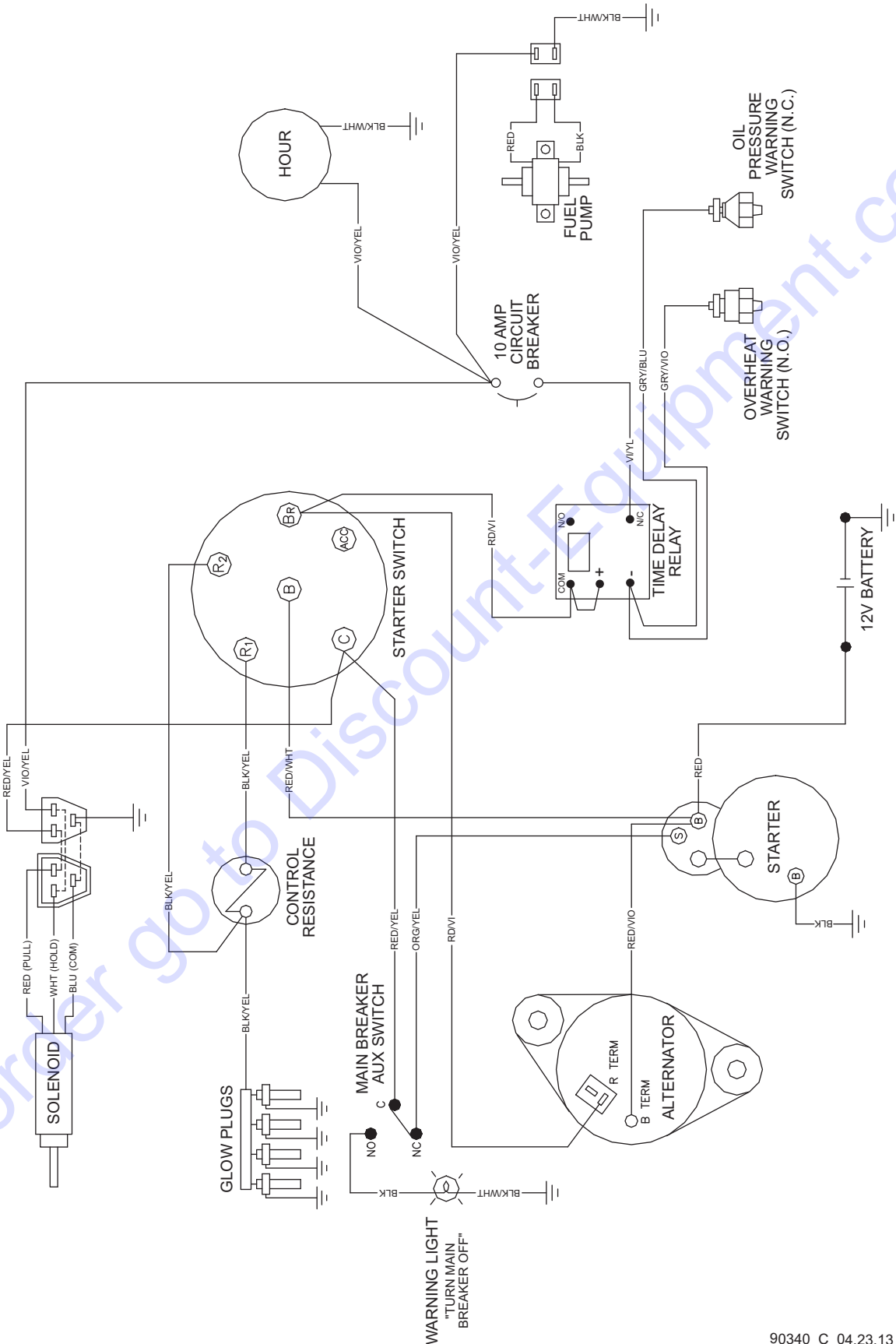

90340\_C\_04.23.13

# DC Wiring Diagram—Kubota

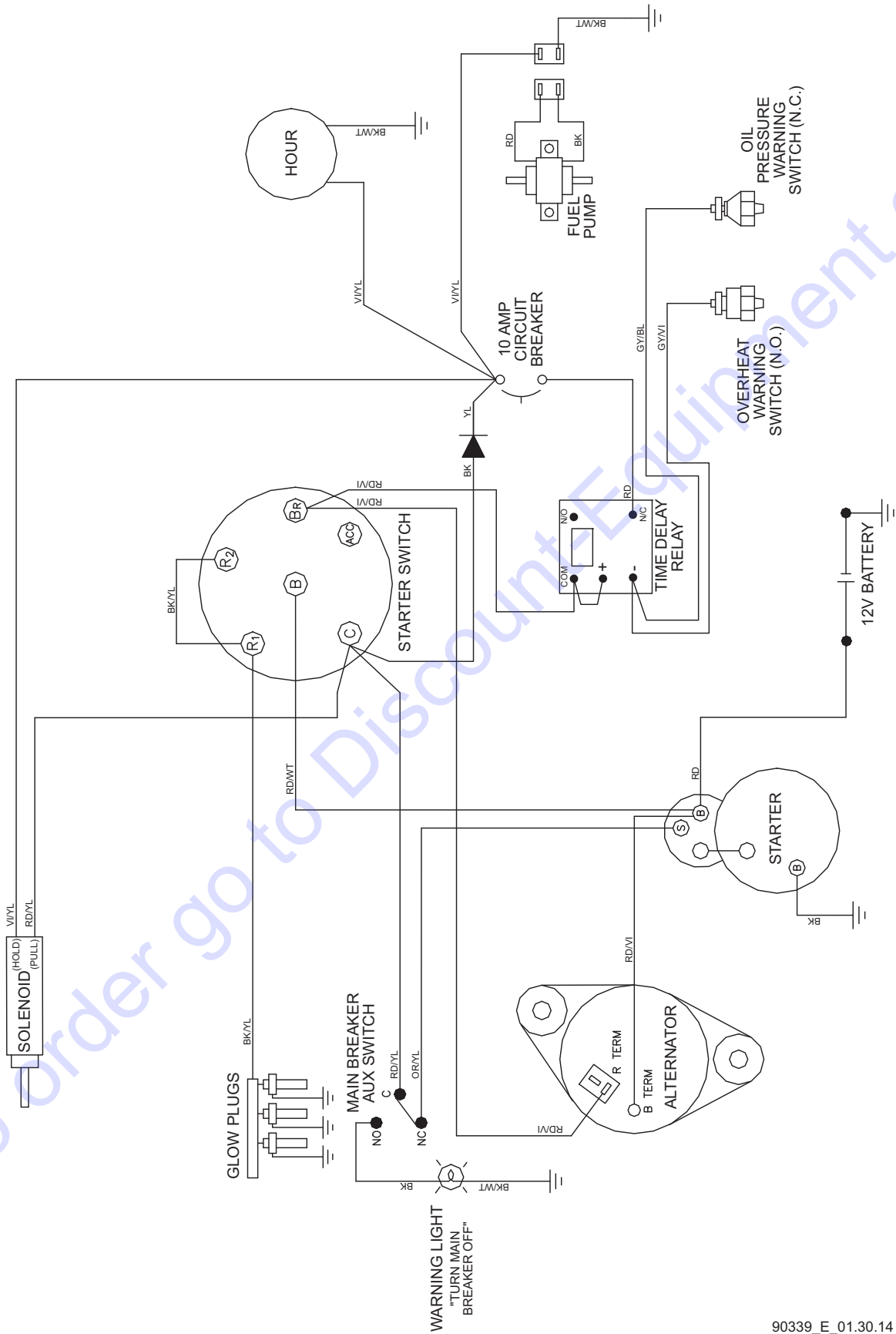

90339\_E\_01.30.14

# DC Wiring Diagram—Electric Winch

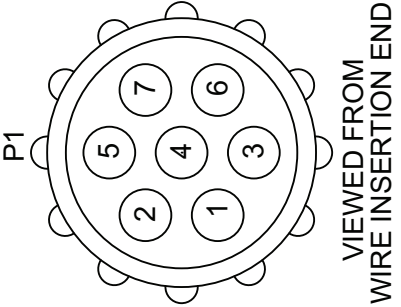
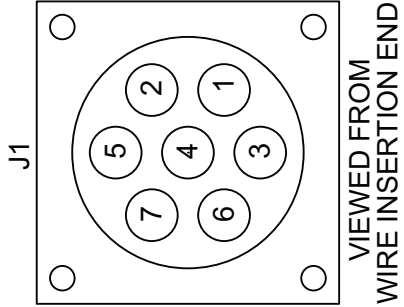
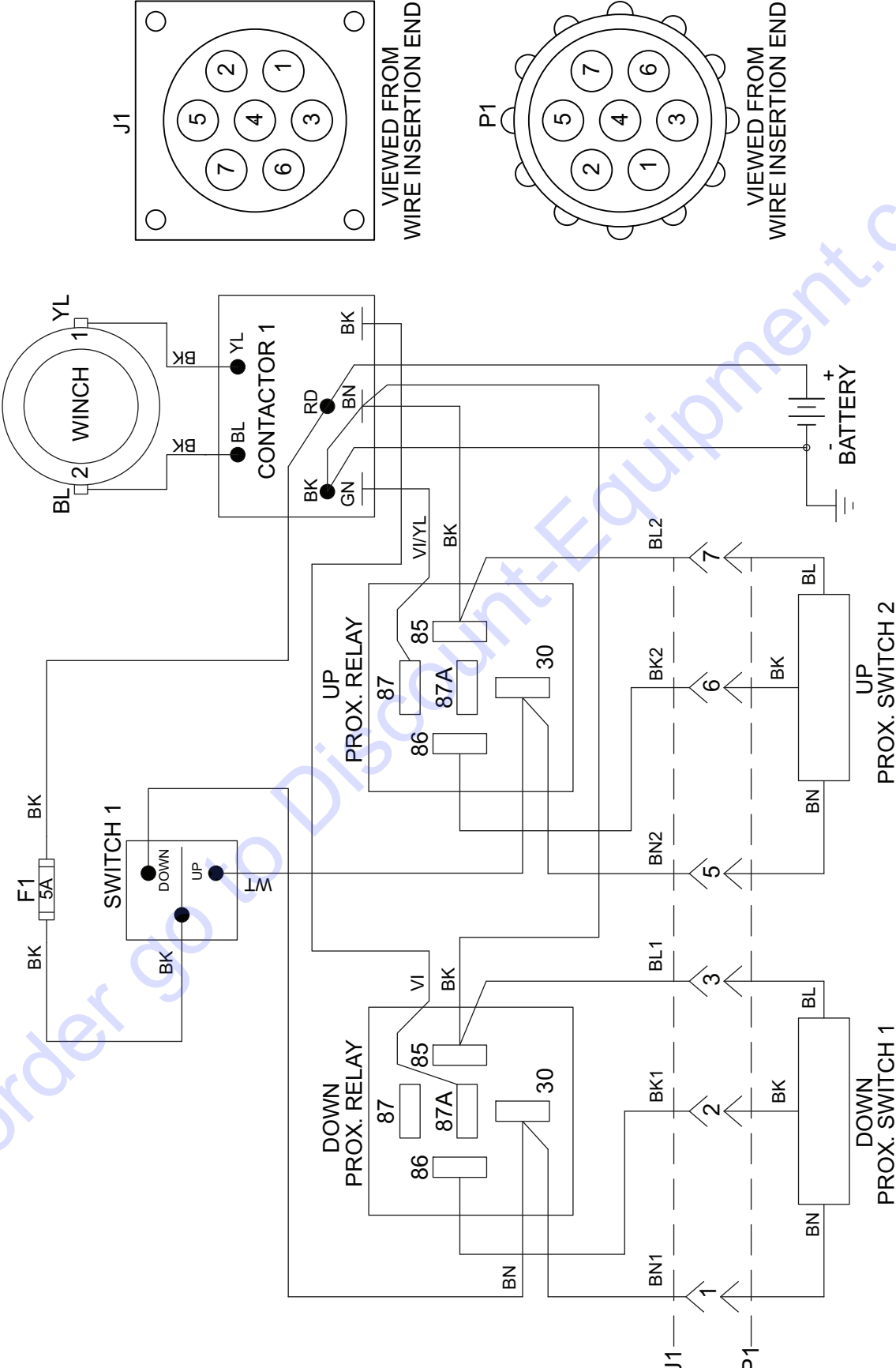

To Order [www.Digital-Equipment.com](http://www.Digital-Equipment.com)

# DC Wiring Diagrams for Optional Equipment

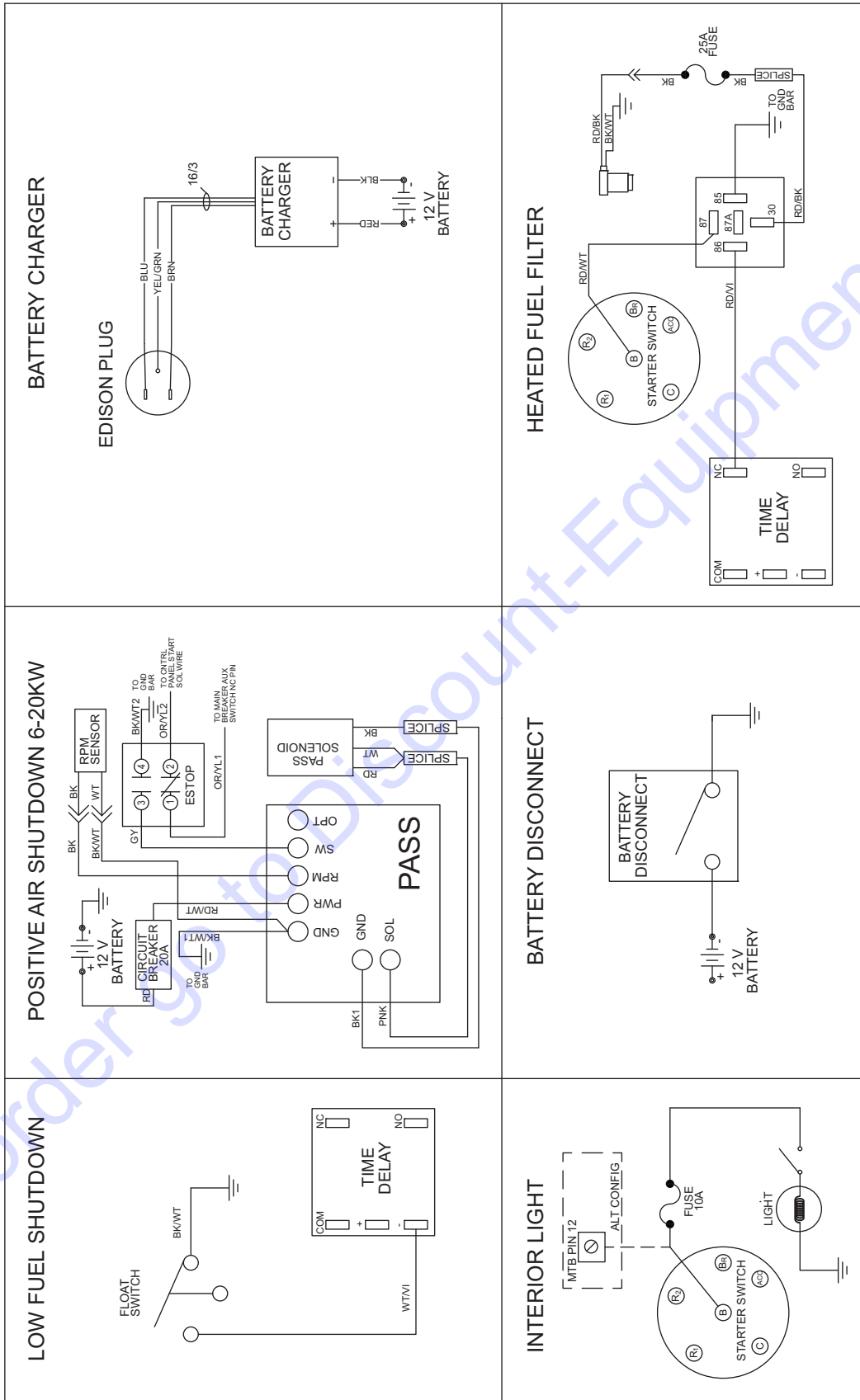

90323\_K\_06.04.14

# Trailer Lights Wiring

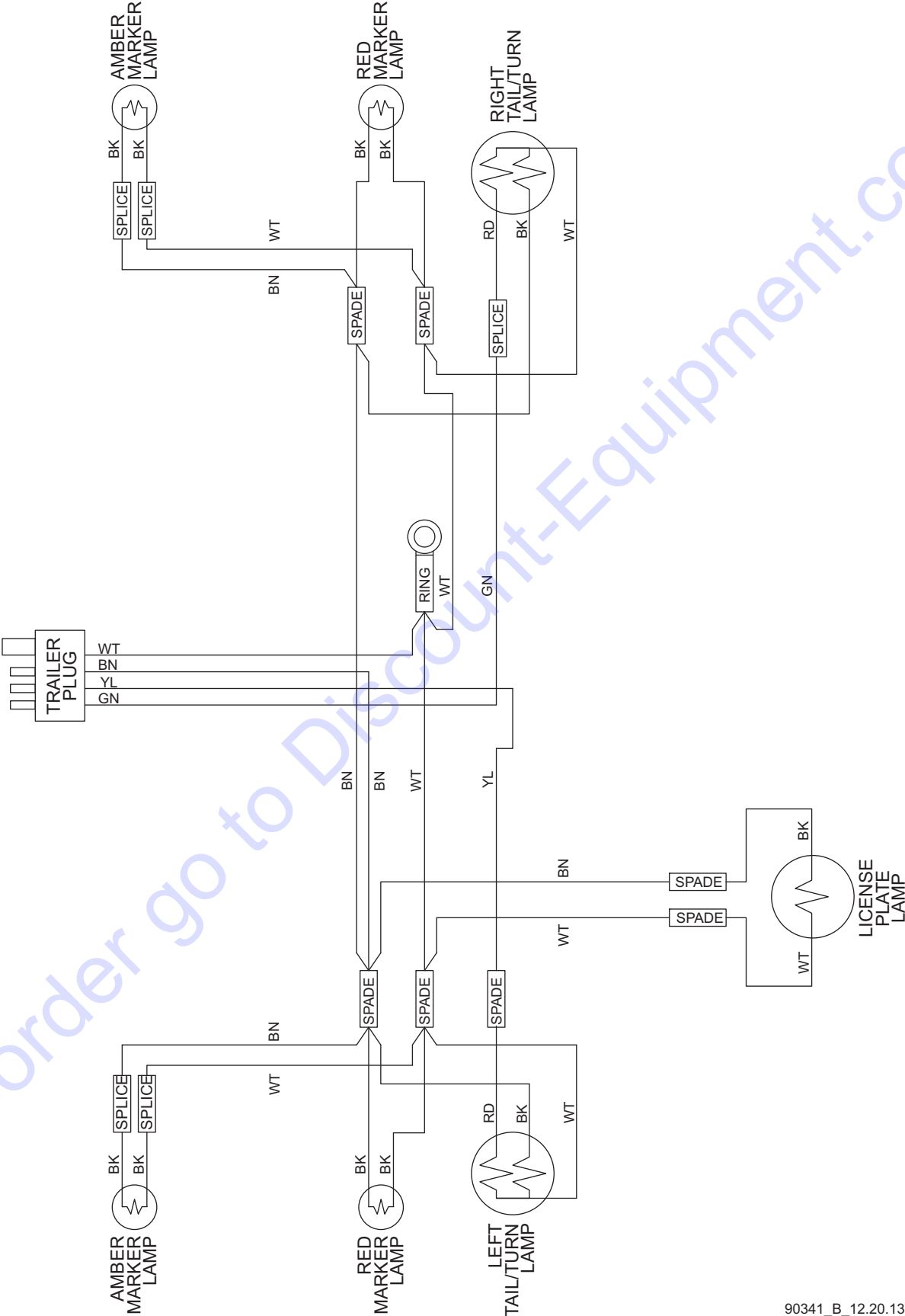

90341\_B\_12.20.13

**This page intentionally left blank.**

To order go to [DiscountEquipment.com](http://DiscountEquipment.com)

**This page intentionally left blank.**

To order go to [Discount-Equipment.com](http://Discount-Equipment.com)

**This page intentionally left blank.**

To order go to [Discount-Equipment.com](http://Discount-Equipment.com)



# Section 7: Service Log

OIL GRADE: \_\_\_\_\_ BRAND: \_\_\_\_\_

COOLANT MIXTURE: \_\_\_\_\_ BRAND: \_\_\_\_\_

---



---



---



---



---



---



---



---



---



---

Date	Hours to Service	Oil Level	Coolant Level

Date	Hours to Service	Oil Level	Coolant Level







To order go to [Discount-Equipment.com](http://Discount-Equipment.com)

To order go to [Discount-Equipment.com](http://Discount-Equipment.com)

Part No. 33298 Rev. D 3/8/17  
©2017 Generac Mobile Products  
All rights reserved.  
Specifications are subject to change without notice.  
No reproduction allowed in any form without prior written  
consent from Generac Mobile Products.

**GENERAC**<sup>®</sup>  
  
**MAGNUM**

**TO PURCHASE THIS PRODUCT PLEASE CONTACT US**



**Equipment Financing and  
Extended Warranties Available**



**Discount-Equipment.com is your online resource for  
commercial and industrial quality parts and equipment sales.**

**561-964-4949**

**visit us on line @ [www.discount-equipment.com](http://www.discount-equipment.com)**

Select an option below to find your Equipment

**Search by Manufacturer**

**Search by Product Type**

**Request a Quote**

We sell worldwide for the brands: Genie, Terex, JLG, MultiQuip, Mikasa, Essick, Whiteman, Mayco, Toro Stone, Diamond Products, Generac Magnum, Airman, Haulotte, Barreto, Power Blanket, Nifty Lift, Atlas Copco, Chicago Pneumatic, Allmand, Miller Curber, Skyjack, Lull, Skytrak, Tsurumi, Husquvarna Target, Stow, Wacker, Sakai, Mi-T-M, Sullair, Basic, Dynapac, MBW, Weber, Bartell, Bennar Newman, Haulotte, Ditch Runner, Menegotti, Morrison, Contec, Buddy, Crown, Edco, Wyco, Bomag, Laymor, EZ Trench, Bil-Jax, F.S. Curtis, Gehl Pavers, Heli, Honda, ICS/PowerGrit, IHI, Partner, Imer, Clipper, MMD, Koshin, Rice, CH&E, General Equipment, Amida, Coleman, NAC, Gradall, Square Shooter, Kent, Stanley, Tamco, Toku, Hatz, Kohler, Robin, Wisconsin, Northrock, Oztec, Toker TK, Rol-Air, APT, Wylie, Ingersoll Rand / Doosan, Innovatech, Con X, Ammann, Mecalac, Makinex, Smith Surface Prep, Small Line, Wanco, Yanmar