

*Owner's Manual*  
For  
*DF 2.2 Dust Suppression System*

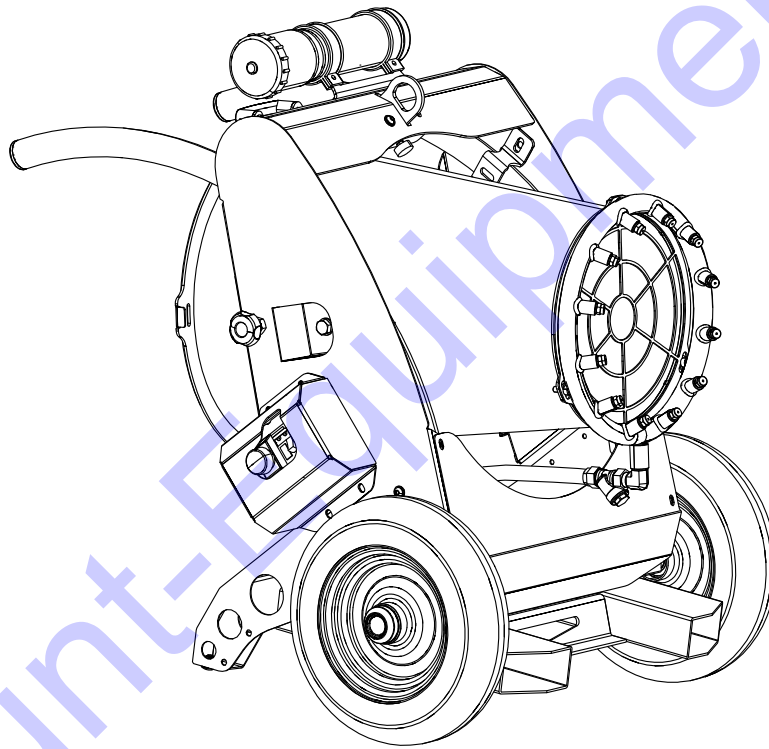

[www.discount-equipment.com](http://www.discount-equipment.com)

**SAVE THIS MANUAL FOR FUTURE REFERENCE**

# **Discount Equipment**

Discount-Equipment.com is your online resource for commercial and industrial quality parts and equipment sales.

## **Locations:**

Florida (West Palm Beach): [561-964-4949](tel:561-964-4949)

Outside Florida TOLL FREE: [877-690-3101](tel:877-690-3101)

**Need parts?** Check out our website at [www.discount-equipment.com](http://www.discount-equipment.com)

## **Can't find what you need?**

Click on this link: <http://www.discount-equipment.com/category/5443-parts/> and fill out the request form.

Please have the machine model and serial number available in order to help us get you the correct parts. One of our experienced staff members will get back to you with a quote for the right part that your machine needs.

We sell worldwide for the brands: Genie, Terex, JLG, MultiQuip, Mayco, Toro/Stone, Diamond Products, Magnum, Airman, Mustang, Power Blanket, Nifty Lift, Atlas Copco, Chicago Pneumatic, Allmand Brothers, Essick, Miller Spreader, Skyjack, Lull, Skytrak, Tsurumi, Husquvarna/Target, Whiteman-Concrete/Mortar, Stow-Concrete/Mortar, Baldor, Wacker, Sakai, Snorkel, Upright, Mi-T-M, Sullair, Neal, Basic, Dynapac, MBW, Weber, Bartell, Bennar Newman, Haulotte, Ditch Runner, Blaw-Knox, Himoina, Best, Buddy, Crown, Edco, Wyco, Bomag, Laymor, Terremite, Barreto, EZ Trench, Takeuchi, Basic, Bil-Jax, Curtis, Gehl, Heli, Honda, ICS/PowerGrit, Puckett, Waldon, ASV, IHI, Partner, Imer, Clipper, MMD, Koshin, Rice, Gorman Rupp, CH&E, Cat Pumps, Comet, General Pump, Giant, AMida, Coleman, NAC, Gradall, Square Shooter, Kent, Stanley, Tamco, Toku, Hatz, Kohler, Robin, Wisconsin, Northrock, Oztec, Toker TK, Rol-Air, Small Line, Wanco, Yanmar

**New Equipment - Used Equipment - Rental Equipment - Parts and Accessories**

# **Discount Equipment**

[www.discount-equipment.com](http://www.discount-equipment.com)

**561-964-4949**

Parts: [wbparts@Discount-Equipment.com](mailto:wbparts@Discount-Equipment.com)

Sales: [info@Discount-Equipment.com](mailto:info@Discount-Equipment.com)

---

**Use this page to record important information about your Generac Mobile Product**

Unit Model Number	
Unit Serial Number	
Date Purchased	

Record the information found on your unit data label on this page.

Engine and generator serial numbers are located on separate data plates affixed to the engine and generator respectively.

When contacting a Generac Mobile Products Authorized Service Dealer (ASD) about parts and service, always supply the complete model number and serial number of the unit.

**Operation and Maintenance:** Proper maintenance and care of the generator ensures a minimum number of problems and keeps operating expenses at a minimum. It is the operator's responsibility to perform all safety checks, to verify that all maintenance for safe operation is performed promptly, and to have the equipment checked periodically by an ASD. Normal maintenance, service and replacement of parts are the responsibility of the owner/operator and, as such, are not considered defects in materials or workmanship within the terms of the warranty. Individual operating habits and usage may contribute to the need for additional maintenance or service.

 **WARNING**

**CANCER AND REPRODUCTIVE HARM**

[www.P65Warnings.ca.gov](http://www.P65Warnings.ca.gov)

(000393a)

# Table of Contents

---

## **Section 1: Introduction and Safety**

<b>Introduction</b> .....	1
Read This Manual Thoroughly .....	1
How to Obtain Service .....	1
<b>Safety Rules</b> .....	1
<b>Safety Symbols and Meanings</b> .....	1
<b>General Hazards</b> .....	2
<b>Electrical Hazards</b> .....	2
<b>Operating Safety</b> .....	3
Positioning the Unit .....	3
Starting the Unit .....	3
<b>Service Safety</b> .....	3

## **Section 2: General Information**

<b>Specifications</b> .....	5
<b>Component Locations</b> .....	5
<b>Setup</b> .....	6
Water System Connection .....	6
Electrical Connection .....	6

## **Section 3: Operation**

<b>Operation and Use Questions</b> .....	7
<b>Before Starting</b> .....	7
<b>Starting the Unit</b> .....	7
<b>Stopping the Unit</b> .....	8
Adjusting Jet Angle .....	8
<b>Lifting the Unit</b> .....	8

## **Section 4: Maintenance and Troubleshooting**

<b>Daily Walk-Around Inspection</b> .....	9
<b>General Maintenance</b> .....	9
Inspecting the Unit .....	9
Preparing for Service .....	9
Cleaning the Unit .....	9
<b>Inlet Filter Cleaning</b> .....	10
<b>Nozzle Cleaning</b> .....	10
<b>General Troubleshooting</b> .....	10

# Section 1: Introduction and Safety

## Introduction

Thank you for purchasing a Generac Mobile Products LLC product. This unit has been designed to provide high performance, efficient operation, and years of use when maintained properly.

The information in this manual is accurate based on products produced at the time of publication. The manufacturer reserves the right to make technical updates, corrections, and product revisions at any time without notice.

### Read This Manual Thoroughly



#### **WARNING**

Consult Manual. Read and understand manual completely before using product. Failure to completely understand manual and product could result in death or serious injury. (000100a)

If any section of this manual is not understood, contact your nearest Generac Mobile Products Authorized Service Dealer (ASD) with any questions or concerns.

The owner is responsible for proper maintenance and safe use of the equipment. Comply with regulations the Occupational Safety and Health Administration (OSHA) has established, or with equivalent standards. Also, verify that the unit is applied, used, and maintained in accordance with the manufacturer's instructions and recommendations. Do nothing that might alter safe application/usage and render the unit in noncompliance with the aforementioned codes, standards, laws, and regulations.

Save these instructions for future reference. This manual contains important instructions for the unit that should be followed during setup, operation and maintenance of the unit and battery. ALWAYS supply this manual to any individual that will use this machine.

### How to Obtain Service

When the unit requires servicing or repairs, contact an ASD for assistance. Service technicians are factory-trained and are capable of handling all service needs.

When contacting an ASD about parts and service, always supply the complete model and serial number of the unit as given on the data decal located on the unit. Record the model and serial numbers in the spaces provided on the front cover of this manual.

## Safety Rules

The manufacturer cannot anticipate every possible circumstance that might involve a hazard. The warnings in this manual, and on tags and decals affixed to the unit are, therefore, not all inclusive. If using a procedure, work method or operating technique that the manufacturer does not specifically recommend, verify it is safe for others. Also make sure the procedure, work method or operating technique utilized does not render the equipment unsafe.

## Safety Symbols and Meanings

Throughout this publication, and on tags and decals affixed to the unit, DANGER, WARNING, CAUTION and NOTE blocks are used to alert personnel to special instructions about a particular operation that may be hazardous if performed incorrectly or carelessly. Observe them carefully. Their definitions are as follows:

#### **DANGER**

Indicates a hazardous situation which, if not avoided, will result in death or serious injury.

(000001)

#### **WARNING**

Indicates a hazardous situation which, if not avoided, could result in death or serious injury.

(000002)

#### **CAUTION**

Indicates a hazardous situation which, if not avoided, could result in minor or moderate injury.

(000003)

**NOTE:** Notes contain additional information important to a procedure and will be found within the regular text of this manual.

These safety alerts cannot eliminate the hazards that they indicate. Common sense and strict compliance with the special instructions while performing the action or service are essential to preventing accidents.

## General Hazards



### ⚠️ WARNING

Hearing Loss. Hearing protection is recommended when using this machine. Failure to wear hearing protection could result in permanent hearing loss. (000107)



### ⚠️ WARNING

Vision loss. Eye protection is required when operating unit. Failure to wear appropriate eye protection could result in vision loss or serious injury. (000407)



### ⚠️ WARNING

Moving Parts. Keep clothing, hair, and appendages away from moving parts. Failure to do so could result in death or serious injury. (000111)

### ⚠️ WARNING

Equipment damage. Do not attempt to start or operate a unit in need of repair or scheduled maintenance. Doing so could result in serious injury, death, or equipment failure or damage. (000291)

### ⚠️ WARNING

Risk of injury. Do not operate or service this machine if not fully alert. Fatigue can impair the ability to service this equipment and could result in death or serious injury. (000215)

### ⚠️ WARNING

Equipment damage. Only qualified service personnel may install, operate, and maintain this equipment. Failure to follow proper installation requirements could result in death, serious injury, and equipment or property damage. (000182a)

### ⚠️ CAUTION

Equipment or property damage. Do not block air intake or restrict proper air flow. Doing so could result in unsafe operation or damage to unit. (000229)

## Electrical Hazards



### ⚠️ DANGER

Electrocution. In the event of electrical accident, immediately shut power OFF. Use non-conductive implements to free victim from live conductor. Apply first aid and get medical help. Failure to do so will result in death or serious injury. (000145)



### ⚠️ DANGER

Electrocution. Water contact with a power source, if not avoided, will result in death or serious injury. (000104)



### ⚠️ DANGER

Electrocution. Verify electrical system is properly grounded before applying power. Failure to do so will result in death or serious injury. (000152)



### ⚠️ DANGER

Electrocution. Do not wear jewelry while working on this equipment. Doing so will result in death or serious injury. (000188)



### ⚠️ DANGER

Electrocution. DO NOT use the unit if electrical cord is cut or worn through. Doing so will result in death or serious injury. (000263a)

## Operating Safety

### Positioning the Unit



Crushing hazard. Verify unit is properly secured and on level ground. An unsecured unit can suddenly roll or move, causing death or serious injury.

(000234a)



Personal injury. Only use water from controlled, reliable sources. Uncontrolled water could contain bacteria. Inhaling mist containing bacteria could result in death, or serious injury.

(000584)



Personal injury. Keep people and pets away from work area. Failure to do so could result in death or serious injury.

(000420)



Personal injury. Never direct air jet toward people or animals. Shut unit OFF immediately if people or animals enter the work area. Failure to do so could result in death or serious injury.

(000585)

- The area immediately surrounding the unit should be dry, clean, and free of debris.
- If the unit is equipped with a frame grounding stud, follow any local, state, and National Electrical Code (NEC) guidelines when connecting.

### Starting the Unit



Electrocution. DO NOT use the unit if electrical cord is cut or worn through. Doing so will result in death or serious injury.

(000263a)



Equipment damage. Do not attempt to start or operate a unit in need of repair or scheduled maintenance. Doing so could result in serious injury, death, or equipment failure or damage.

(000291)

## Service Safety



Before servicing unit, shut unit down, turn water supply OFF, and disconnect unit from power source. Failure to do so could result in death, serious injury, or equipment damage.

(000586)

### Lifting Hazards



Personal injury. Failure to properly connect lifting cables, chains, or straps could result in death, serious injury, or property damage.

(000346)



Personal Injury. Do not use lifting eye if there are signs of damage or corrosion. Doing so could result in death, serious injury, or property damage.

(000433)



Personal Injury. Do not use lifting eye other than as directed. Doing so could result in death, serious injury, or property damage.

(000434)



Personal Injury. Verify all fasteners are properly tightened prior to lifting unit. Failure to do so could result in death, serious injury, or property damage.

(000351)

## Section 2: General Information

### Specifications

Description	Units	DF 2.2
Voltage	V	240
Hertz	Hz	60
Pump Power	kW	2.2
Electric Connection	-	L6-15 NEMA twistlock
Water Connection	-	3/4" garden hose
Fan	-	9 Nylon blades, aluminum hub
Nominal Pressure	psi (bar)	14.5 (1) - 72.5 (5)
Water Consumption	psi -- gal/min (bar --l/min)	14.5 -- 1.44 (1.0 – 5.4) 21.8 -- 1.74 (1.5 – 6.6) 29 -- 1.98 (2.0 – 7.5) 36.3 -- 2.25 (2.5 – 8.5)
Air Flow	ft <sup>3</sup> /min (mm <sup>3</sup> /min)	295 (90)
Water Inlet Filter	µm	300
Nozzles Holder	-	Stainless steel w/ 12 connection
Tilting Angle	°	10 to 50
Weight	lb (kg)	175 (79)
Dimensions	L x W x H ft (L x W x H mm)	3.3 X 2.6 X 2.74 (985 x 785 x 835)

*Specifications are subject to change without notice. Refer to the product specification sheet for complete list.*

### Component Locations

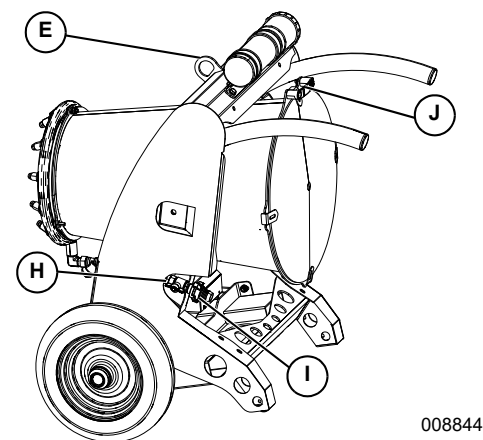
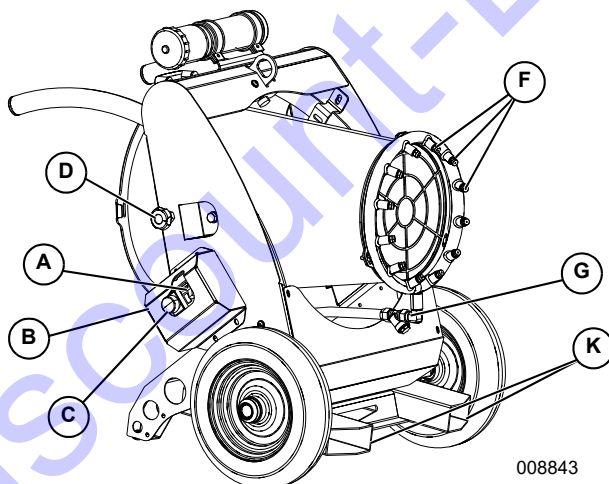

**Figure 2-1. Component Locations**

- |                              |                       |                                |
|------------------------------|-----------------------|--------------------------------|
| <b>A</b> Start Button        | <b>E</b> Lifting Hook | <b>I</b> Water Connection      |
| <b>B</b> Socket              | <b>F</b> Nozzles      | <b>J</b> Tilting Blower Handle |
| <b>C</b> Stop Button         | <b>G</b> Water Filter | <b>K</b> Forklift Pockets      |
| <b>D</b> Tilting Blower Knob | <b>H</b> Water Tap    |                                |



## Setup

### Water System Connection



Personal injury. Only use water from controlled, reliable sources. Uncontrolled water could contain bacteria. Inhaling mist containing bacteria could result in death, or serious injury. (000584)

1. See **Figure 2-2**. Verify water valve (A) is closed.

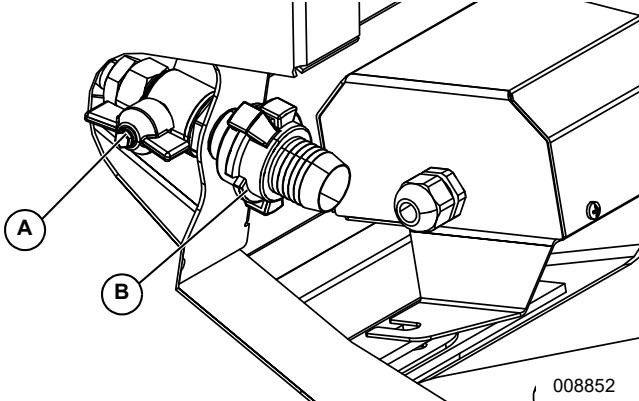

**Figure 2-2. Connecting Water Supply**

2. Connect water supply to water fitting (B).

### Electrical Connection



**⚠ DANGER**

Electrocution. In the event of electrical accident, immediately shut power OFF. Use non-conductive implements to free victim from live conductor. Apply first aid and get medical help. Failure to do so will result in death or serious injury. (000145)



**⚠ DANGER**

Electrocution. Verify electrical system is properly grounded before applying power. Failure to do so will result in death or serious injury. (000152)



**⚠ DANGER**

Electrocution. Water contact with a power source, if not avoided, will result in death or serious injury. (000104)

1. See **Figure 2-3**. Verify switch (A) is in OFF position.

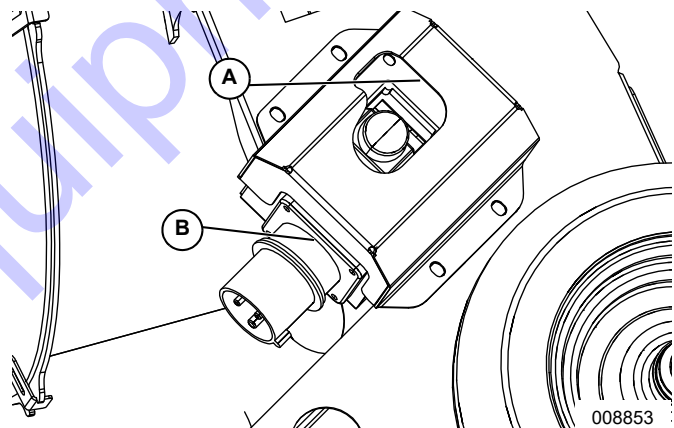

**Figure 2-3. Electrical Connection**

2. Connect to socket (B) 240v power with the following requirements:
  - Extension cord must be marked “WA” or indicate it is suitable for outdoor use.
  - Power source must be equipped with residual-current device (RCD) protection.
  - Use adequately sized extension cords of appropriate length. See **Table 1** for recommended cable size and length.

**Table 1 - Recommended Shore Power Cable Size and Length**

Suggested Power Cables and Lengths	
50 ft. (15.2 m)	10/3—(L5-20P – L5-20R)
100 ft. (30.5 m)	12/3—(5-15P – 5-15R)

## Section 3: Operation



### **DANGER**

Electrocution. In the event of electrical accident, immediately shut power OFF. Use non-conductive implements to free victim from live conductor. Apply first aid and get medical help. Failure to do so will result in death or serious injury. (000145)



### **DANGER**

Electrocution. Verify electrical system is properly grounded before applying power. Failure to do so will result in death or serious injury. (000152)



### **DANGER**

Electrocution. Water contact with a power source, if not avoided, will result in death or serious injury. (000104)



### **WARNING**

Consult Manual. Read and understand manual completely before using product. Failure to completely understand manual and product could result in death or serious injury. (000100a)

### **WARNING**

Equipment damage. Do not attempt to start or operate a unit in need of repair or scheduled maintenance. Doing so could result in serious injury, death, or equipment failure or damage. (000291)

### **WARNING**

Personal injury. Never direct air jet toward people or animals. Shut unit OFF immediately if people or animals enter the work area. Failure to do so could result in death or serious injury. (000585)

### **WARNING**

Personal injury. Keep people and pets away from work area. Failure to do so could result in death or serious injury. (000420)

### **WARNING**

Personal injury. Only use water from controlled, reliable sources. Uncontrolled water could contain bacteria. Inhaling mist containing bacteria could result in death, or serious injury. (000584)

## Operation and Use Questions

Contact your nearest Generac Mobile Products Authorized Service Dealer (ASD), or contact Generac Mobile Products Technical Service at 1-800-926-9768 or [www.generacmobileproducts.com](http://www.generacmobileproducts.com) with any questions or concerns about unit operation and maintenance.

## Before Starting

1. Place unit on flat ground in a well ventilated area.
2. Place barriers 6 ft (2 m) around unit to prevent unauthorized personnel from nearing unit.
3. Verify sufficient water supply is properly connected See [Water System Connection](#).
4. Inspect all electrical cords; repair or replace any cords that are cut, worn, or bare.
5. Verify power cord is properly connected to a 240 volt 60 hz power source. See [Electrical Connection](#).

**NOTE:** For grounding requirements, follow the National Electrical Code (NEC), state, and local regulations.

## Starting the Unit

1. See [Figure 3-1](#). Press start button (A) to start fan.

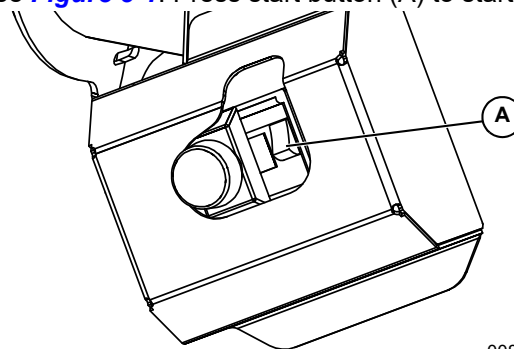

008856

**Figure 3-1. Starting the Unit**

2. See [Figure 3-2](#). Open valve (B).

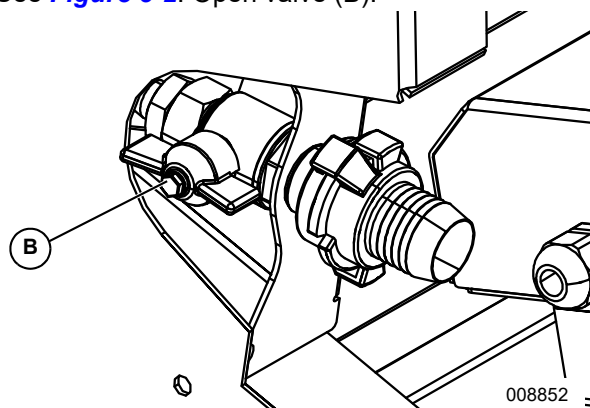

008852

**Figure 3-2. Starting the Unit**

## Stopping the Unit

1. See **Figure 3-1**. Close water valve (A).
2. Wait for water to stop spraying from nozzles (B).

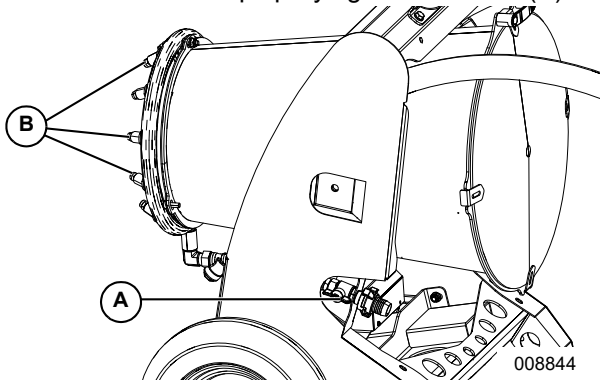

**Figure 3-3. Stopping the Unit**

3. See **Figure 3-4**. Press stop button (C).

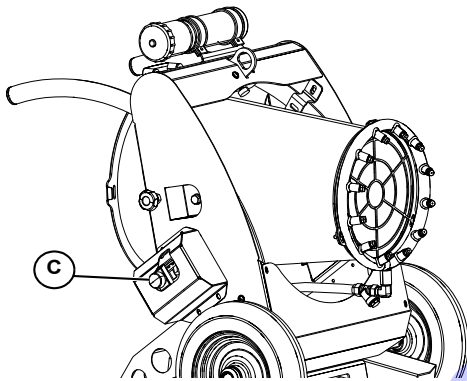

**Figure 3-4. Stopping the Unit**

## Adjusting Jet Angle

1. See **Figure 3-5**. Pull tilting blower knob (A).
2. Use handle (B) to tilt blower to desired angle.
3. Release tilting blower knob to lock position.

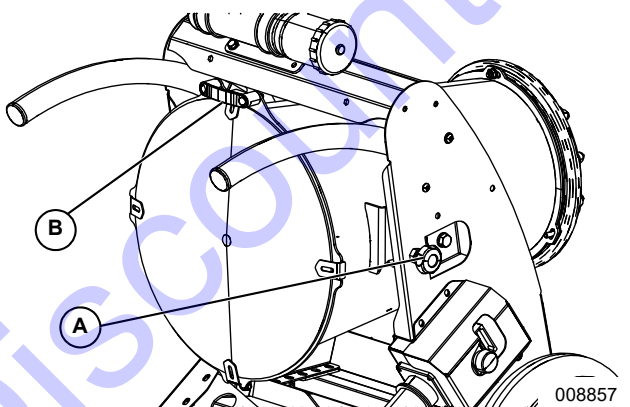

**Figure 3-5. Adjusting Jet Angle**

## Lifting the Unit



### ⚠ WARNING

Personal injury. Failure to properly connect lifting cables, chains, or straps could result in death, serious injury, or property damage.

(000346)

### ⚠ WARNING

Personal Injury. Do not use lifting eye if there are signs of damage or corrosion. Doing so could result in death, serious injury, or property damage.

(000433)

### ⚠ WARNING

Personal Injury. Do not use lifting eye other than as directed. Doing so could result in death, serious injury, or property damage.

(000434)

1. Verify the equipment being used to lift the unit is in good condition and has sufficient capacity. For approximate weights, see **Specifications**.
2. See **Figure 3-6**. Always remain aware of people and objects around the work site when moving or lifting the unit.
  - When lifting the unit, attach any slings, chains, or hooks directly to the central lift point (A).
  - Use forklift pockets (B) with care. Avoid approaching the unit at an angle, as this can permanently damage the forklift pockets, tires, or cabinet. Verify any obstructions are clear of the forklift tines before lifting.

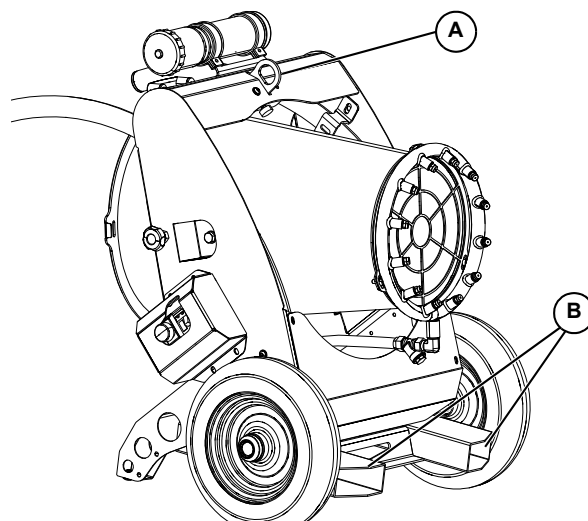

**Figure 3-6. Lifting Points**

# Section 4: Maintenance and Troubleshooting

## ⚠ WARNING

Before servicing unit, shut unit down, turn water supply OFF, and disconnect unit from power source. Failure to do so could result in death, serious injury, or equipment damage.

(000586)

## Daily Walk-Around Inspection

Perform a walk-around inspection of the unit every day before starting the unit. Look for conditions that could hinder performance or safety, such as (but not limited to) damaged or missing parts and hardware, and loose or broken electrical connections.

## ⚠ CAUTION

Equipment Damage. Failure to perform a daily inspection could result in damage to the unit.

(000306)

## General Maintenance

Maintenance Activity	After First Operation	Before Each Use	Semi-Annually
Check all electrical connections		◆	
Clean Inlet Filter			◆
Clean Nozzles			◆

Poorly maintained equipment can become a safety hazard. In order for the equipment to operate safely and properly over a long period of time, periodic maintenance and occasional repairs are necessary. **DO NOT** perform routine service unless all electrical components are OFF.

Regular maintenance will improve performance and extend engine/equipment life. Generac Mobile Products LLC recommends all maintenance work be performed by a Generac Mobile Products Authorized Dealer (ASD).

### Inspecting the Unit

- If the unit is stored outside, check for water inside the cabinet and control panel cover before each use. If wet, dry the unit thoroughly before starting.
- Inspect condition of electrical cords. **DO NOT** use the unit if insulation is cut or worn through.
- Verify the wheels and locking caster are present and in serviceable condition.

### Preparing for Service

Before servicing the unit, always follow the instructions listed below.

1. Verify unit power switch is OFF.
2. Disconnect shore power from the unit.
3. Disconnect water supply from the unit.
4. Attach a DO NOT USE sign to the control panel. This will notify everyone that the unit is being serviced and will reduce the chance of someone inadvertently trying to start the unit.

### Cleaning the Unit

See **Figure 4-1**. After each use, clean nozzles (A) with a water solution and antilimestone product.

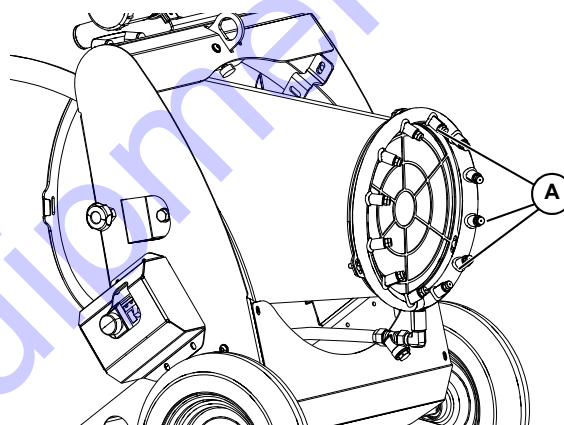

Figure 4-1. Cleaning the Unit

Always clean the unit after each use to remove dust, grease, mud, or spilled fuel or oil. Use soft, clean rags to wipe the cabinet exterior and control panel. Low-pressure compressed air (less than 40 PSI [276 kPa]) can also be used to remove dust and debris from the cabinet interior.

This unit contains sensitive electronic components that can be damaged by high pressure, heat and moisture. Do not wash the unit with a high pressure hose or power washer. Water may enter the cabinet and collect in the control panel or other electrical parts, causing damage.

## Inlet Filter Cleaning

1. **Figure 4-2.** Remove inlet filter plug (A).
2. Remove filter cartridge.
3. Tap cartridge on a solid surface and blow with compressed air to remove sediment.
4. Install cartridge and replace inlet filter plug.

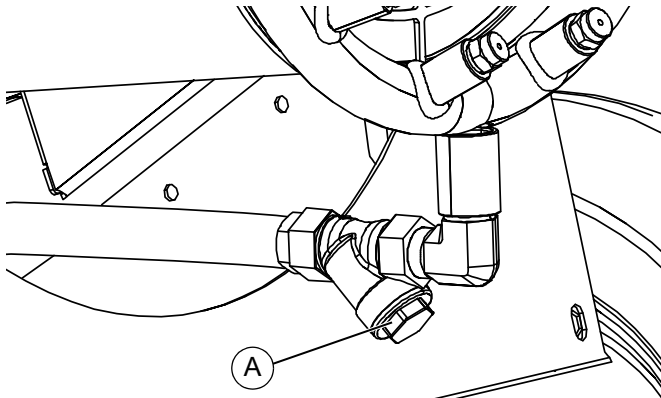

**Figure 4-2. Cleaning Inlet Filter**

## Nozzle Cleaning

1. Remove nozzles from blower cone with a wrench.
2. Soak nozzles in an antilimestone solution overnight.
3. Rinse nozzles.
4. Reinstall nozzles.

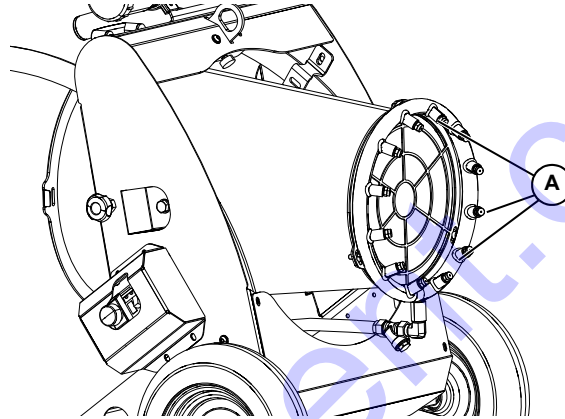

**Figure 4-3. Cleaning Nozzles**

## General Troubleshooting

This information is intended to be a check or verification for simple causes that can be located and fixed. It does not cover all types of problems. See the engine operator's manual for additional troubleshooting information. Procedures that require in-depth knowledge or skills should be performed by an ASD.

Problem	Possible Cause	Solution
Fan Doesn't work	Plug not correctly connected	Verify plug is seated fully in socket.
Uneven water jet	Dirty or clogged nozzles	Clean nozzles. See <a href="#">Nozzle Cleaning</a> .



[www.discount-equipment.com](http://www.discount-equipment.com)

Part No. 10000024569 Rev. A 10/19/18  
©2018 Generac Power Systems, Inc.  
All rights reserved  
Specifications are subject to change without notice.  
No reproduction allowed in any form without prior written  
consent from Generac Power Systems, Inc.

**GENERAC** | **MOBILE**