

CH&E

Division of  **MAGNUM™**

Operating and Maintenance Manual
2" Gas Engine Powered Diaphragm Pumps

Models 5438-6438

Keep this information guide or a copy of it with the pump. Contact Magnum Products LLC for additional copies if this manual should become lost. If you have any questions regarding operating or servicing this pump please contact Magnum Products LLC at 1-800-926-9768.

215 Power Dr
Berlin, WI 54923

Tel (920) 361.4442
Fax (920) 361.4416

Operation Manual Contents:

- Serial Number/Model Number Information Pg. 2
- Safety Information Pg. 3
- Service Safety Information Pg. 4
- Pump Specifications Pg. 5
- Sound Specifications Pg. 6
- Operating Instructions Pg. 6
- Pump Diagram Pg. 7
- Maintenance Requirements Pg. 8
- Changing a Diaphragm Pg. 8
- Changing a Flap Valves Pg. 8
- Troubleshooting Guide Pg. 9
- Exploded View Pg.10
- Parts List Pg. 11
- Parts List Con't Pg. 12
- Exploded View (Skid & Wheel Mounting) Pg. 13
- Parts List (Skid & Wheel Mounting) Pg. 14
-

Serial Number / Model Number:

A nameplate listing the Model Number and Serial Number is located on each pump. **The Model Number and Serial Number are necessary for ordering parts or requesting service; it is important that you document these numbers.**

Record Model Number and Serial Number Here:

Serial Number

Model Number

Safety Information:

Operator Safety: Internal Combustion Engines

DANGER! INDICATES AN IMMINENTLY HAZARDOUS SITUATION, FAILURE TO ABIDE BY SAFETY PRECAUTIONS WILL RESULT IN DEATH OR SERIOUS INJURY.

DO NOT operate in an enclosed area, as exhaust fumes are lethal.
DO NOT smoke while operating pump.
DO NOT smoke when refueling engine.
DO NOT refuel hot or running engine.
DO NOT spill fuel when refueling.
DO NOT refuel or operate near an open flame.

DO replace the fuel cap after refueling.

WARNING! INDICATES A POTENTIALLY HAZARDOUS SITUATION, FAILURE TO FOLLOW INSTRUCTIONS MAY RESULT IN DEATH OR SERIOUS INJURY.

DO NOT operate this equipment without fully understanding the operations procedures.
DO NOT touch hot surfaces, particularly the muffler; doing so may cause serious burns.
DO NOT attempt to clear blockages or clean the pump during operation. Rotating parts may cause serious injury.
DO NOT pump flammable liquids.
DO NOT pump corrosive liquids. Contact local authorities for assistance.

DO read, understand, and follow pump and operation manual procedures.
DO be sure pump is on a firm, level surface and will not tip, roll or fall while in operation.
DO operate pump only when guards are in place.
DO store equipment properly when it is not in use. Equipment should be stored in a clean, safe location.

CAUTION! INDICATES A POTENTIALLY HAZARDOUS SITUATION, FAILURE TO FOLLOW INSTRUCTIONS MAY RESULT IN A MINOR INJURY OR SEVERE DAMAGE TO THE PUMP.

DO NOT reduce the size of the discharge or try to control capacity by throttling the discharge; severe damage to the pump will result.

DO drain the pump in freezing weather by tipping the unit towards the discharge.
DO flush the pump with clean water after operation to remove any dirt and debris still in the pump.

Service Safety:

WARNING! POORLY MAINTAINED EQUIPMENT CAN BECOME A SAFETY HAZARD! IN ORDER FOR THE PUMP TO OPERATE SAFELY AND PROPERLY, PERIODIC MAINTENANCE AND OCCASIONAL REPAIRS ARE NECESSARY.

DO NOT attempt to clean or service the pump while it is running. Rotating parts can cause severe injury.

DO NOT crank a flooded engine with the spark plug removed on gasoline-powered engines.

DO NOT test for spark on gasoline-powered engines if engine is flooded or the smell of gasoline is present.

DO NOT use gasoline or other types of fuels or flammable solvents to clean parts. Fumes from these fuels and solvents can accumulate and cause an explosion.

DO operate the pump with all safety devices and guards in place and in working order.

DO keep the area around the muffler free of debris. A hot muffler may ignite the debris.

DO replace worn or damaged equipment with recommended parts.

DO disconnect the spark plug on pumps with gasoline-powered engines before servicing the pump to avoid an accidental start.

MODELS 5438 & 6438

2" DIAPHRAGM PUMP WITH HONDA GX160K1 GAS ENGINE

PUMP SPECIFICATIONS

POWER	HONDA GX160K1 GAS ENGINE
	4.1kw 5.5hp
ENGINE SPEED	2700 rpm
PUMP SPEED	63 strokes per minute
CAPACITY	189 l/m (50gpm)
SUCTION LIFT	7.5m (25ft)
DISCHARGE HEAD	7.5m (25ft)
SUCTION CONNECTION	50mm (2in)
DISCHARGE CONNECTION	50mm (2in)
SOLID HANDLING SIZE	30mm (1.2in)
WEIGHT (MODEL 5438)	52kg (115lb)
WEIGHT (MODEL 6438)	70kg (154lb)
SOUND PRESSURE LEVEL	83db(A); pump under load; engine speed 2800rpm; per EN ISO 3744:1995

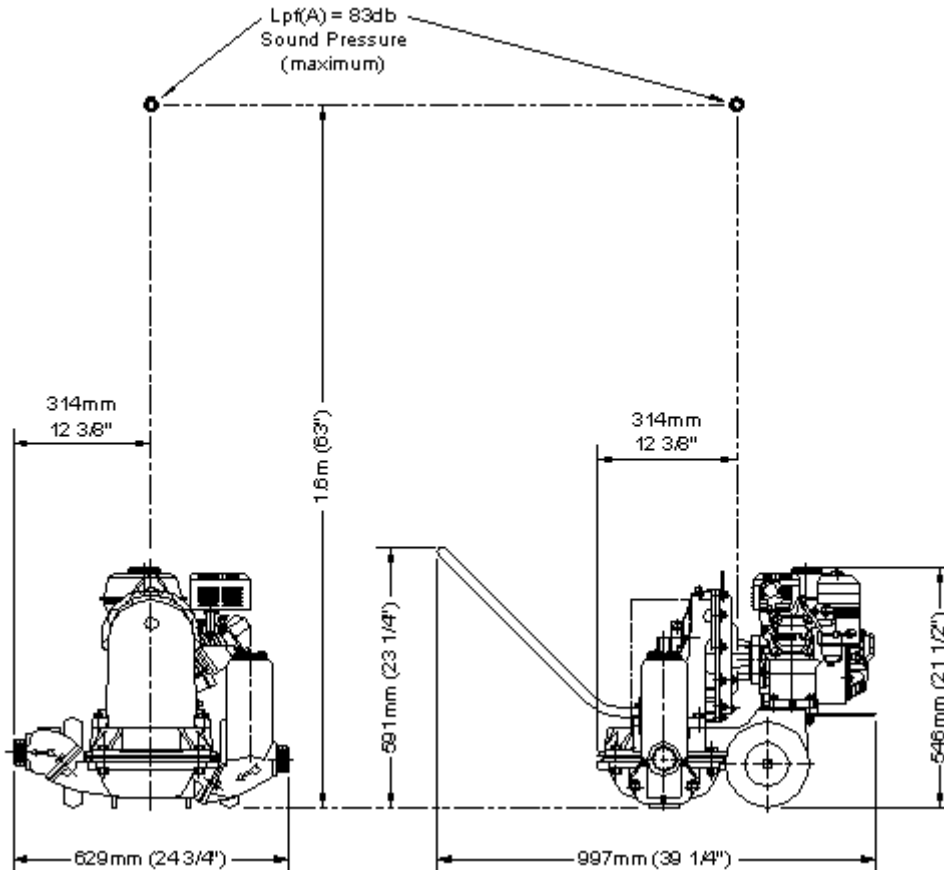

Sound Measurement Specifications:

The required sound specifications, per Appendix 1, Paragraph 1.7.4.f of the EC-Machine Regulations, are:

- The sound pressure level at operator's location (L_{pA}) = 83 db (A)
- The sound power level (L_{WA}) = 95 db (A)

These sound values were determined according to the ISO 3744 for the sound power level (L_{WA}) and ISO 6081 for the sound pressure level (L_{pA}) at the operator's location.

The sound measurements were obtained with the unit operating on pavement at nominal speed.

Operating Instructions:

1. Read the "Pump Safety" pamphlet in its entirety before operating the pump and observe safe operating procedures at all times.
2. Read the engine operator manual in order to understand proper starting and stopping techniques. **Always start and stop the engine in accordance with the engine manufacturer's instructions.**
3. Examine the pump carefully and read all instructions before beginning pump operation.
 - a. Notify the transportation company at once of any damage or loss that may have occurred during transit.
4. When using a suction hose, make sure the gasket is in place and in good shape.
 - a. When using pipes, coat the threads with a sealing compound.
5. Make sure that the suction hose does not leak and that the lining is not loose or it will collapse under suction pressure and block the hose.
 - a. To pump at maximum capacity, use a hose or pipe of the same size or larger than the pump discharge.
6. Priming time depends on the height of the vertical suction lift, the length of hose between the pump and the water level and the speed of the pump.
 - a. Maximum practical suction lift is approximately 25ft vertically from the surface of the water to the pump suction.
 - b. Fastest priming and greatest capacity are achieved at low suction lifts.
 - c. For maximum performance, locate the pump close to water.
 - d. The pump will also prime faster at higher speeds.
7. On high suction lifts, or if the pump has been idle and the valves are dry, remove the cap on the suction chamber and fill the pump with water.
 - a. This will help to seal the valves and speed up priming time.
8. Pump speed can be regulated with the engine throttle control.
 - a. Limit maximum speed to 65 strokes (diaphragm) per minute (2800 rpm engine speed)
 - b. Smoothest pump operation may be achieved by trying the pump at several speeds.

Pump Diagram:

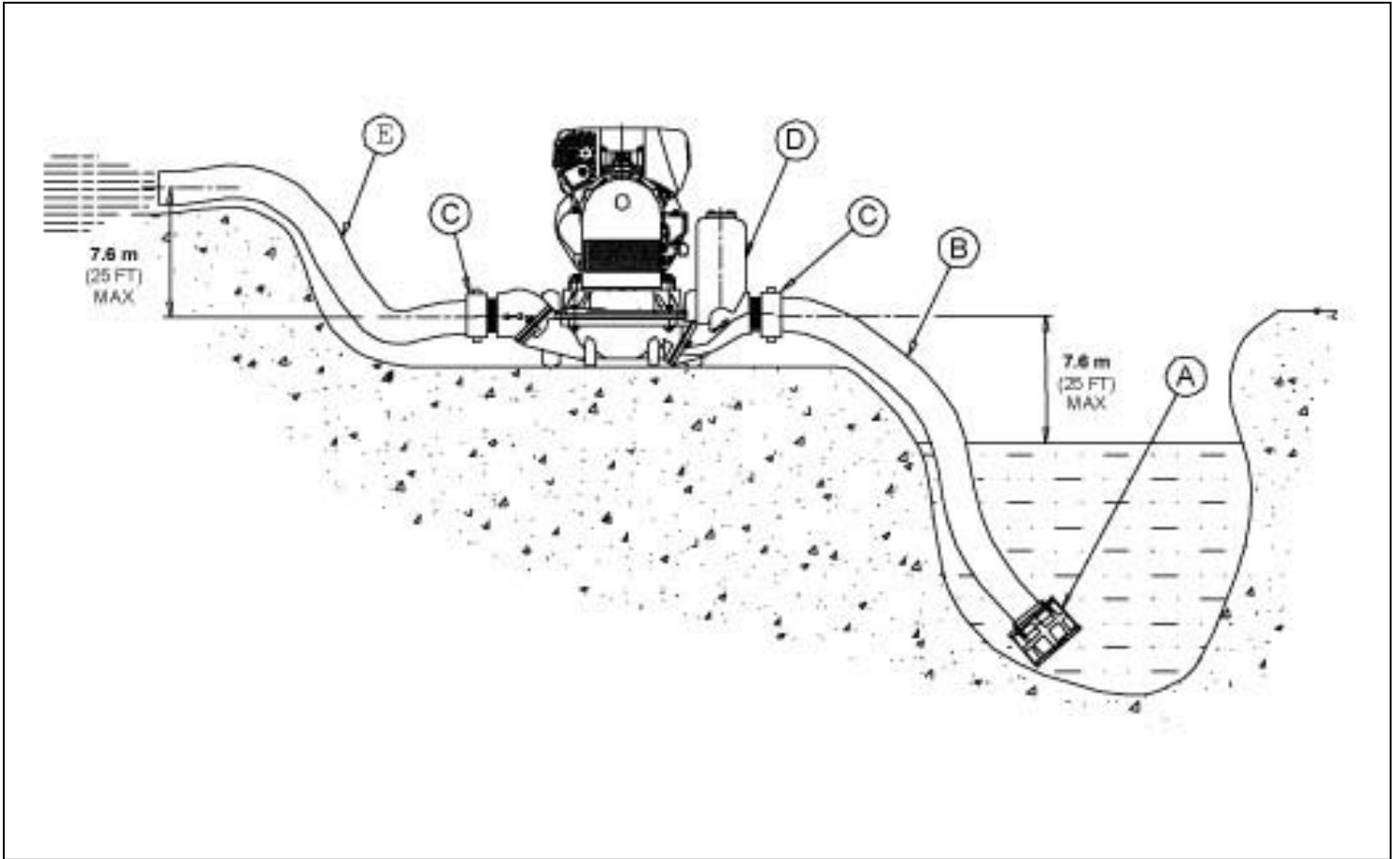

Maintenance Requirements:

For engine maintenance, refer to the engine operation manual.

1. Change the transmission oil after the first 40 hours of operation.
 - a. Use SAE 80/90 EP gear oil.
 - b. Capacity is 20oz (550ml, 1 ¼ pints).
 - c. Fill with oil to the oil level plug located in the transmission cover.
 - d. Check the oil level daily before beginning operation.
2. Change the transmission oil every 400 hours of operation after the initial (40 hour) oil change.
3. Every 25 hours of operation, grease the pump connecting rod bearing by accessing it through the connecting rod guard.
4. Keep the interior of the pump and the valves clean.
5. Flush out the pump with clean water after every operation.
6. Remove the pump connecting rod guard occasionally and clean the excess grease from the pump connecting rod bearing.

Changing a Diaphragm:

1. Rotate the pump connecting rod to the down position by slowly pulling on the engine starter rope.
2. Remove the four bolts that clamp the diaphragm between the pump frame and the water box.
3. Remove the three nuts from the bolts that clamp the diaphragm between the connecting rod and the diaphragm bottom plate.
4. Install the new diaphragm onto the bolts and diaphragm bottom plate.
5. Using a pipe spacer over the bolts, drive the diaphragm down into position on the diaphragm bottom plate.
6. Install the diaphragm and diaphragm bottom plate assembly onto the connecting rod.
7. Tighten the three nuts and torque:
 - a. For 2" Pumps: 34-40N-m (25-30lb/ft)
 - b. For 3" Pumps: 45-54N-m (35-40lb/ft)
8. Center the diaphragm carefully over the water box and clamp with four bolts to the pump frame.
9. Tighten the bolts in a crossing pattern and torque:
 - a. For 2" Pumps: 34-40N-m (25-30lb/ft)
 - b. For 3" Pumps: 45-54N-m (35-40lb/ft)

Changing Flap Valves:

1. Remove the suction connection, discharge connection, and flap valves.
2. Install the weight and binder plates onto the new flap valve.
 - a. Use a thread-sealing compound on the screws.
 - b. Tighten the screws firmly but make sure that they do not distort the rubber, which would cause poor seating.
3. Install the flap valves on the valve seats of the water box and suction connection with the binder (the smaller plate) facing down into the hole.
4. Locate the flap valves on the spring pins in the suction connection and on the water box.
5. Reassemble the suction and discharge connections to the water box.
6. Tighten the bolts and torque:
 - a. For 2" Pumps: 20-34N-m (15-20lb/ft)
 - b. For 3" Pumps: 27-34N-m (20-25lb/ft)

Troubleshooting Guide:

Problem	Possible Reason
<p>Pump does not prime AND/OR Pump does not operate properly.</p>	<ol style="list-style-type: none"> 1. Pump may be too high above or too far away from the water source. 2. There may be leaks in the suction hose or hose connection. 3. Valves may not be sealing properly due to accumulation of residue. Pour water into the suction chamber to seal the valves. 4. Valves may not seal due to distortion. Adjust the tightness of the suction and discharge connection mounting bolts. 5. Check diaphragm for breaks and/or leaks. 6. Ensure that the end of the suction line is in position to allow water to enter. The suction line may be buried or blocked. 7. Do not allow any point of the suction hose to be higher than the suction connection on the pump. A trapped air pocket can form and prevent priming. 8. The pump will not operate properly under a positive suction head condition.
<p>Reduced Capacity.</p>	<ol style="list-style-type: none"> 1. The discharge line may be too small, too high or too long causing: <ol style="list-style-type: none"> a. Excessive bulging of diaphragm on the down stroke. b. Valves closing with a loud snap. c. Overall rough operation. d. Engine overloads and then slows down. <p>*Diaphragm pumps will handle fluids containing a considerable amount of solids, however, if the mixture is too heavy to be pumped, liquid must be added until the mixture becomes sufficiently fluid for pumping.</p>

#5400-#6400, #5500-#6500

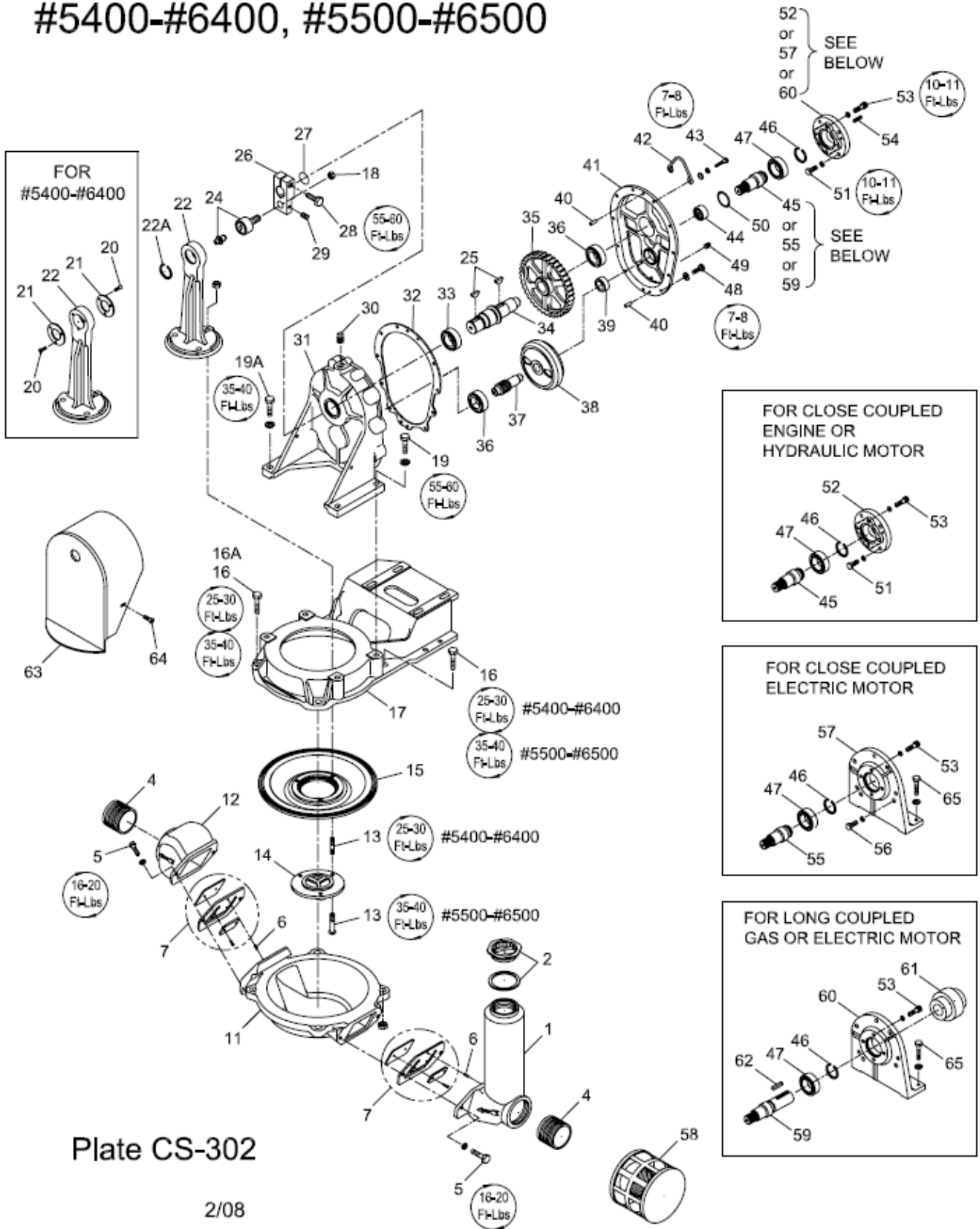

Models 5438-6438 2" Diaphragm Pumps, GAS Powered Close Coupled

Ref. No.	5438 Aluminum	6438 Cast Iron	Qty.	Description
1	P3354-A1	P3354-C2	1	2" Suction Connection
2	P3322-P3323	P3322-P3323	1	Plug with Gasket Assembly
4	P3015	P3015	2	2" Nipple
5	A010.037.0150	A010.037.0150	4	3/8"-16 x 1 1/2" Hex Screw & L.W.
6	18-051	18-051	2	1/8" x 3/8" Spring Pin
7	SA-10003N	SA-10003N	2	2" Flap Valve Assembly
11	P3351-A1	P3351-C2	1	Water Box
12	P3355-A1	P3355-C2	1	2" Discharge Connection
13	P3458	P3458	3	3/8"-16 x 2" Stud & H.N.
14	P3353-A1	P3353-C2	1	Diaphragm Bottom
15	P2331	P2331	1	#2E Diaphragm
16	A010.050.0225	A010.050.0225	4	1/2"-13 x 2 1/4" Hex Screw & H.N. – Wheel Mtg.
			2	1/2"-13 x 2 1/4" Hex Screw & H.N. – Cage & Skid Mtg.
16A	A010.050.0250	A010.050.0250	2	1/2"-13 x 2 1/2" Hex Screw & H.N. – Skid Mtg.
	A010.050.0275	A010.050.0275	2	1/2"-13 x 2 3/4" Hex Screw, H.N. & B.W. – Cage Mtg.
17	P3350	P3350	1	Pump Frame
18	EF410.062	EF410.062	1	5/8"-18UNF Jam Lock Nut
19	A010.050.0175	A010.050.0175	4	1/2"-13 x 1 3/4" Hex Screw & L.W. – Cage & Skid Mtg.
			2	1/2"-13 x 1 3/4" Hex Screw & L.W. – Wheel Mtg.
19A	A010.050.0250	A010.050.0250	2	1/2"-13 x 2 1/2" Hex Screw & L.W. – Wheel Mtg.
20	DF200.R19.0050Z	DF200.R19.0050Z	6	#10-32 x 1/2" Flat Phillips Head Screw
21	P3360	P3360	2	Retaining Washer
22	P3352	P3352	1	Connecting Rod
24	P5582	P5582	1	Connecting Rod Bearing w/W33-3/16 Grease Fitting
25	W70-807	W70-807	2	Woodruff Key
26	P5584	P5584	1	Crank Arm
27	W35-C12329CRW1	W35-C12329CRW1	1	Lip Seal
28	A010.050.0150	A010.050.0150	1	1/2"-13 x 1 1/2" Hex Screw
29	BC090.C031.031	BC090.C031.031	1	5/16"-18 x 5/16" Socket Set Screw
30	R454A	R454A	1	3/8" Vented Pipe Plug
31	P4850P	P4850P	1	Case
32	P4858	P4858	1	Gasket
33	W16-6307	W16-6307	1	Ball Bearing
34	P4853	P4853	1	Gear Shaft
35	P5058	P5058	1	79 Tooth Gear
36	W16-6304	W16-6304	2	Ball Bearing
37	P4852	P4852	1	11 Tooth Pinion
38	P3417	P3417	1	85 Tooth Internal Gear
39	W16-6302	W16-6302	1	Ball Bearing
40	H705.025.0075	H705.025.0075	2	1/4" x 3/4" Dowel Pin
41	P4851P	P4851P	1	Cover
42	P4945	P4945	1	Lifting Hook
43	A010.025.0125	A010.025.0125	2	1/4"-20 x 1 1/4" Hex Screw, L.W. & F.W.
44	W19-TB188	W19-TB188	1	Needle Bearing
45	P4854	P4854	1	14 Tooth Pinion (3/4" Bore)
46	W63-5100-118	W63-5100-118	1	Retaining Ring
47	W16-6006LLU	W16-6006LLU	1	Ball Bearing

Ref. No.	5438 Aluminum	6438 Cast Iron	Qty.	Description
48	A010.025.0100	A010.025.0100	9	1/4"-20 x 1" Hex Screw & L.W.
49	0002-1603	0002-1603	2	1/8" Square Head Pipe Plug
50	W63-T11141SM	W63-T11141SM	1	Lip Seal
51	AF010.031.0100Z	AF010.031.0100Z	4	5/16"-24 x 1" Hex Screw & L.W.
52	P4856	P4856	1	Engine Adapter
53	BC070.031.0100	BC070.031.0100	4	5/16"-18 x 1" Socket Screw & LKI.W.
54	P5601	P5601	1	3/16" Sq x 1" Key
58	P3364	P3364	1	2" NPT Strainer
63	P3691	P3691	1	Crank Arm Guard
64	DC290.X19.050FZ	DC290.X19.050FZ	2	#10-24 x 1/2" Washer Head Self Tap Screw

Flap Valve Assemblies Available:

(Requires two per pump)

SA-10003B - Buna-N
SA-10003N - Neoprene
SA-10004N - Neoprene with Cloth Insert

Diaphragm Pump Rebuild Kits Available:

(Diaphragm and Flapper Assemblies including hardware)

W103-020.0T - TPE
W103-020.0R - Rubber
W103-020.0N - Neoprene
W103-020.0B - Buna-N

#5400-#6400 SKID MOUNTING

Plate CS-302E

10/08

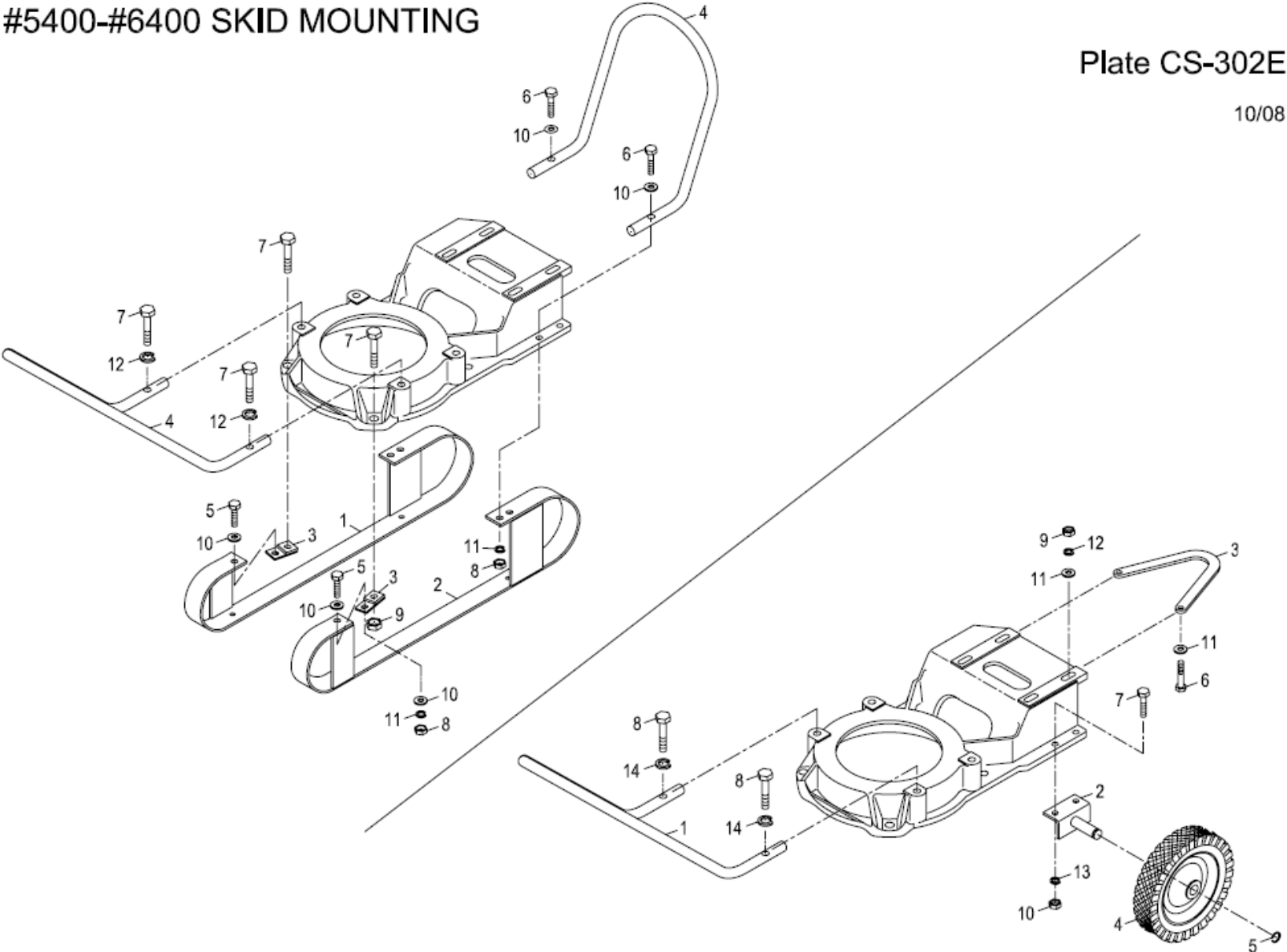

#5400-#6400 WHEEL MOUNTING

5438(ce)-6438(ce) Gas

Models 5438-6438
Skid Mounting Close Coupled

Ref. No.	5438 Aluminum	6438 Cast Iron	Qty.	Description
1	P3324L	P3324L	1	Skid Frame Left
2	P3324R	P3324R	1	Skid Frame Right
3	P3363	P3363	2	Skid Extension
4	P3320A	P3320A	2	Towing Pole
5	A010.037.0100	A010.037.0100	2	3/8"-16 x 1" Hex Screw, H.N., L.W. & (2) F.W.
6	A010.037.0225	A010.037.0225	2	3/8"-16 x 2 1/4" Hex Screw, H.N., L.W. & F.W.
7	A010.050.0250	A010.050.0250	2	1/2"-13 x 2 1/2" Hex Screw & H.N.
			2	1/2"-13 x 2 1/2" Hex Screw & L.W.
8	EC400.037	EC400.037	4	3/8"-16 Hex Nut
9	EC400.050	EC400.050	2	1/2"-13 Hex Nut
10	F601.037Y	F601.037Y	6	3/8" Flat Washer
11	F620.037	F620.037	4	3/8" Lock Washer
12	F620.050	F620.050	2	1/2" Lock Washer

Models 5438-6438
Wheel Mounting Close Coupled

Ref. No.	5438 Aluminum	6438 Cast Iron	Qty.	Description
1	P4779	P4779	2	Stub Axle
2	P3320A	P3320A	1	Towing Pole
3	P3327	P3327	1	Bumper
4	W27-4A	W27-4A	2	Wheel 8" x 1.75" Semi-Pneumatic
5	W63-5133-75	W63-5133-75	2	Retaining Ring
6	A010.031.0225	A010.031.0225	2	5/16"-18 x 2 1/4" Hex Screw, H.N., L.W. & F.W.
7	A010.037.0125	A010.037.0125	4	3/8"-16 x 1 1/4" Hex Screw, H.N. & L.W.
8	A010.050.0250	A010.050.0250	2	1/2"-13 x 2 1/2" Hex Screw & L.W.
9	EC400.031	EC400.031	2	5/16"-18 Hex Nut
10	EC400.037	EC400.037	4	3/8"-16 Hex Nut
11	F601.031Y	F601.031Y	4	5/16" Flat Washer
12	F620.031	F620.031	2	5/16"-18 Lock Washer
13	F620.037	F620.037	4	3/8"-16 Lock Washer
14	F620.050	F620.050	2	1/2"-13 Lock Washer
	P2676	P2676	As Req'd	Shim, SI 25/64" X 7/8" X .015" Stl (Not Shown)