

CONTEC®

HORNET

Kugelstrahlmaschine / Mobile Shotblaster

Betriebsanleitung (Originalausgabe)
Instruction manual (Original edition)



230 V, 50 Hz



110/115 V, 50/60 Hz

**Discount
Equipment**

www.Discount-Equipment.com

Inhaltsverzeichnis / Index

1	EG-Konformitätserklärung / EC-Declaration of Conformity	...3
2	Anwendungsbereich der Maschine / Machine applications	...4
3	Technische Daten / Technical Data	...4
4	Sicherheitsregeln für den Betrieb der Kugelstrahlanlage Safety rules for operating the shotblaster	...5
5	Inbetriebnahme und Strahlen / Operating and blasting	...6
6	Einstellung und Wartung / Maintenance & Adjustment	...9
6.1	Einstellen des Strahlbildes / Adjust the blasting path	...9
6.2	Verschleiß am Schleuderrad und an der Einlaufbuchse Wear & tear on the blast wheel and shot cage	...9
7.	Fehler und Behebung / Troubleshooting	...11
8.	Verschleißteile / Wear & Tear parts	...12
9.	Strahlmittel / Shot	...12
10.	Anhang / Appendix	...12

EG-Konformitätserklärung

gemäß der EG-Maschinen-Richtlinie 2006/42/EG vom 17. Mai 2006, Anhang II A

Hiermit erklären wir, dass die nachstehend bezeichnete Maschine in ihrer Konzeption und Bauart sowie in der von uns in Verkehr gebrachten Ausführung den grundlegenden Sicherheits- und Gesundheitsanforderungen der EG-Richtlinie 2006/42 EG entspricht. Bei einer mit uns nicht abgestimmten Änderung der Maschine verliert diese Erklärung ihre Gültigkeit.

Hersteller: Contec Maschinenbau & Entwicklungstechnik GmbH, Hauptstraße 146, 57518 Alsdorf, Deutschland

Beschreibung und Identifizierung der Maschine:

Bezeichnung:	Kugelstrahlmaschine	Modell:	HORNET
Seriennummer:		Baujahr:	

Es wird die Übereinstimmung mit weiteren, ebenfalls für das Produkt geltenden Richtlinien/Bestimmungen erklärt:
EMV-Richtlinie (2004/108/EG) vom 15. Dezember 2004

Angewandte harmonisierte Normen insbesondere:

DIN EN 12100 Sicherheit von Maschinen – Grundbegriffe, allgemeine Gestaltungsleitsätze, : Grundsätzliche Terminologie, Methodik, Risikobeurteilung
DIN EN 60204-1 Sicherheit von Maschinen – Elektrische Ausrüstungen von Maschinen, Teil1: Allgemeine Anforderungen

Bevollmächtigter für die technische Dokumentation: Johannes Greb, Technische Leitung

Alsdorf, 05.03.18 

EC-Declaration of Conformity

In accordance with the EEC Machine Directive 2006/42/EG of 17 May 2006, Appendix II A

We hereby certify that the following described machine in its conception, construction and form put by us into circulation is in accordance with all the relevant essential health and safety requirements of the EC Machinery Directive 2006/42/EEC as amended and the national laws and regulations adopting this directive. This declaration is no longer valid if the machine is modified without our consent.

Manufacturer: Contec Maschinenbau & Entwicklungstechnik GmbH, Hauptstraße 146, 57518 Alsdorf, Germany

Description of the machine:

Function:	Shotblaster	Model:	HORNET
Serial number:		Year:	

The agreement with further valid guidelines/regulations following for the products is explained:
EMV-Richtlinie (2004/108/EG) of 15. December 2004

Other applied harmonized standards and specifications in particular:

DIN EN 12100 Sicherheit von Maschinen – Grundbegriffe, allgemeine Gestaltungsleitsätze, : Grundsätzliche Terminologie, Methodik, Risikobeurteilung
DIN EN 60204-1 Sicherheit von Maschinen – Elektrische Ausrüstungen von Maschinen, Teil1: Allgemeine Anforderungen

Authorized person for the technical documentation: Johannes Greb, Technical Manager

Alsdorf, 05.03.18 

2. Anwendungsbereich der Maschine:	2. Machine applications
Kugelstrahlen von horizontalen, trockenen Böden wie Beton- und Stahlflächen mit und ohne Beschichtung und Asphalt durch Einsatz des von CONTEC® angebotenen Strahlmittels. Der Einsatz außerhalb geschlossener Räume ist nur bei trockenem Wetter gestattet. Der Betrieb ist nur mit einer von CONTEC® empfohlenen Absauganlage gestattet.	Shotblasting of horizontal, dry floors such as concrete and steel surfaces with or without a coating and asphalt using CONTEC® blasting tools. The use of the machine outside is only possible in dry weather. The operation must only be carried out in conjunction with a from CONTEC® recommended dust collector.

3. Technische Daten		3. Technical Data																																																					
<table border="1"> <tr><td>Arbeitsbreite</td><td>200 mm</td></tr> <tr><td>Maschinenbreite</td><td>31.5 cm</td></tr> <tr><td>Maschinenlänge</td><td>73-78 cm</td></tr> <tr><td>Maschinenhöhe</td><td>100-108 cm</td></tr> <tr><td>Installierte Leistung</td><td>2.2 KW bei 230 V</td></tr> <tr><td>Erforderlicher Anschluss</td><td>230 V, 16 A</td></tr> <tr><td>Gewicht</td><td>51 kg</td></tr> <tr><td>Absaugstutzen ϕ</td><td>70 mm</td></tr> <tr><td>Schwingungsgesamtwert a_{hv} *</td><td>2.8 m/s²</td></tr> <tr><td>Schalleistungspegel L_{wa} *</td><td>97 dB(A)</td></tr> <tr><td>Dauerschallpegel Leq *</td><td>86 dB(A)</td></tr> </table>	Arbeitsbreite	200 mm	Maschinenbreite	31.5 cm	Maschinenlänge	73-78 cm	Maschinenhöhe	100-108 cm	Installierte Leistung	2.2 KW bei 230 V	Erforderlicher Anschluss	230 V, 16 A	Gewicht	51 kg	Absaugstutzen ϕ	70 mm	Schwingungsgesamtwert a_{hv} *	2.8 m/s ²	Schalleistungspegel L_{wa} *	97 dB(A)	Dauerschallpegel Leq *	86 dB(A)	<table border="1"> <tr><td>Working breadth (mm)</td><td>200 mm (8 in)</td></tr> <tr><td>Width</td><td>31.5 cm (12.6 in)</td></tr> <tr><td>Length</td><td>73-78 cm (29.2-31.2 in)</td></tr> <tr><td>Height</td><td>100-108 cm (40-43.2 in)</td></tr> <tr><td></td><td>Europe</td><td>USA</td></tr> <tr><td>Turbine power</td><td>2.2 KW, 230 V, 50 Hz or 2.1 KW, 115 V, 50 Hz</td><td>2.1 kW (2.9 hp), 110 V, 60 Hz</td></tr> <tr><td>Power requirements</td><td>230 V, 16 A or 115 V, 20 A</td><td>110 V, 1 phase, 20 A</td></tr> <tr><td>Weight</td><td>51 kg</td><td>51 kg (113 lbs)</td></tr> <tr><td>Dust port ϕ</td><td colspan="2">70 mm (2.8 in)</td></tr> <tr><td>Average value of acceleration a_{hv} *</td><td colspan="2">2.8 m/s²</td></tr> <tr><td>Noise level L_{wa} *</td><td colspan="2">97 dB(A)</td></tr> <tr><td>Noise level Leq *</td><td colspan="2">86 dB(A)</td></tr> </table>	Working breadth (mm)	200 mm (8 in)	Width	31.5 cm (12.6 in)	Length	73-78 cm (29.2-31.2 in)	Height	100-108 cm (40-43.2 in)		Europe	USA	Turbine power	2.2 KW, 230 V, 50 Hz or 2.1 KW, 115 V, 50 Hz	2.1 kW (2.9 hp), 110 V, 60 Hz	Power requirements	230 V, 16 A or 115 V, 20 A	110 V, 1 phase, 20 A	Weight	51 kg	51 kg (113 lbs)	Dust port ϕ	70 mm (2.8 in)		Average value of acceleration a_{hv} *	2.8 m/s ²		Noise level L_{wa} *	97 dB(A)		Noise level Leq *	86 dB(A)	
Arbeitsbreite	200 mm																																																						
Maschinenbreite	31.5 cm																																																						
Maschinenlänge	73-78 cm																																																						
Maschinenhöhe	100-108 cm																																																						
Installierte Leistung	2.2 KW bei 230 V																																																						
Erforderlicher Anschluss	230 V, 16 A																																																						
Gewicht	51 kg																																																						
Absaugstutzen ϕ	70 mm																																																						
Schwingungsgesamtwert a_{hv} *	2.8 m/s ²																																																						
Schalleistungspegel L_{wa} *	97 dB(A)																																																						
Dauerschallpegel Leq *	86 dB(A)																																																						
Working breadth (mm)	200 mm (8 in)																																																						
Width	31.5 cm (12.6 in)																																																						
Length	73-78 cm (29.2-31.2 in)																																																						
Height	100-108 cm (40-43.2 in)																																																						
	Europe	USA																																																					
Turbine power	2.2 KW, 230 V, 50 Hz or 2.1 KW, 115 V, 50 Hz	2.1 kW (2.9 hp), 110 V, 60 Hz																																																					
Power requirements	230 V, 16 A or 115 V, 20 A	110 V, 1 phase, 20 A																																																					
Weight	51 kg	51 kg (113 lbs)																																																					
Dust port ϕ	70 mm (2.8 in)																																																						
Average value of acceleration a_{hv} *	2.8 m/s ²																																																						
Noise level L_{wa} *	97 dB(A)																																																						
Noise level Leq *	86 dB(A)																																																						

* Messwerte / Data: VÜA Verein zur Überwachung technischer Anlagen e.V.
 Technische Änderungen vorbehalten / Subject to alterations

4. Sicherheitsregeln für den Betrieb der Kugelstrahlanlage	4. Safety Rules for operating the Shotblast Machine
<p>Die mobile Kugelstrahlanlage HORNET ist unter Berücksichtigung geltender Sicherheitsvorkehrungen entwickelt worden. Die technischen Sicherheitsvorkehrungen dürfen auf keinen Fall entfernt oder verändert werden. Beim Betrieb der Anlage sollten außerdem folgende Punkte beachtet werden:</p> <p>Bevor irgendwelche Arbeiten, auch kleinster Art, an der Maschine vorgenommen werden, muss der Netzstecker gezogen werden.</p> <p>Beim HORNET werden hohe mechanische Leistungen übertragen. Die Verletzungsgefahr besteht also nicht nur durch einen elektrischen Schock, sondern auch durch sich drehende Teile.</p> <p>Der Gebrauch von Schutzmitteln wie Brillen mit Seitenschutz und Ohrenschützern ist erforderlich. Alle Personen, die sich im Arbeitsbereich der Maschine befinden, müssen diese Schutzmittel tragen. Beim erstmaligen Anlauf der Strahlmaschine und beim Liften / Kippen der Maschine während des Strahlens ist es möglich, daß Strahlmittel mit hoher Geschwindigkeit aus der Strahlöffnung austritt. Es besteht in diesem Fall hohe Verletzungsgefahr für die Augen.</p> <p>Tragen Sie Kleidung, die fest am Körper anliegt. Flatternde Kleidungsstücke können in die Maschine gelangen und in sie hineingezogen werden.</p> <p>Alle drehenden Teile der Maschine sind mit Abdeckungen versehen, die verhindern sollen, dass Körper- Kleidungs- oder sonstige Fremtteile hineingelangen. Lassen Sie alle Abdeckungen an ihrem Platz, bevor die Maschine aktiviert wird.</p> <p>Der Zutritt von unbefugten Personen in den Arbeitsbereich der Maschine muß verhindert werden. (Hohe Rutschgefahr auf liegendegebliebenem Strahlmittel)</p>	<p>The HORNET Mobile Shotblast Machine is constructed according to existing safety rules and regulations. These technical precautions should not be removed or changed under any circumstances. While operating the machine the following items should also be kept in mind:</p> <p>Disconnect the machine before commencing any servicing or maintenance work - however minimal.</p> <p>In nearly every part of the HORNET high electrical currents and mechanical forces are transmitted. The danger of injury is therefore not only from electric shock, but also from moving parts of the machine.</p> <p>It is necessary to use safety goggles with side protectors and ear plugs. All persons, in the operating area of the Shotblaster must take these precautions. When switching on, or lifting the machine during blasting, it is possible that shot escapes at high speed. Unprotected eyes can be seriously damaged in this case.</p> <p>Never wear loose or badly fitting clothing. Flapping sleeves may be pulled into the machine causing serious injury.</p> <p>All rotating parts of the machine are suitably protected by covers, which prevent clothes or similar from entering the machine. Under no circumstances should these covers be removed before you switch the machine on.</p> <p>Access by unauthorised persons into the blasting area should be prevented. (Due to a high risk of slipping on lost shot)</p>

<p>Werden während des Betriebs von HORNET ungewöhnliche Laufgeräusche oder erhöhte Vibrationen registriert, muss die Maschine unverzüglich abgeschaltet werden und die Ursache des außergewöhnlichen Verhaltens ergründet werden.</p> <p>Die zu strahlende Fläche muss vor der Behandlung auf grobe Unebenheiten, Steine, Metallstücke und ähnliches überprüft werden. Gegebenenfalls muss die Fläche gefegt oder abgesaugt werden. Nasse oder verölte Stellen können den Strahlvorgang unmöglich machen und Schäden in der Absauganlage verursachen.</p> <p>Eine regelmäßige Kontrolle der zuführenden Stromkabel ist nötig, da diese beim Betrieb der Anlage mechanische Schäden erlitten haben könnten. (vorher Netzstecker ziehen!) Behandeln Sie alle spannungsführenden Teile mit größter Sorgfalt.</p>	<p>The HORNET should be switched off immediately if unusual noises or vibrations are detected during the operating of the machinery. A thorough check must be carried out in order to detect the cause.</p> <p>Always pre check the floor for undulations, steps, stones, screws or other foreign bodies. It might be necessary to brush, or in extreme cases, vacuum the floor. Wet or oily spots can make blasting impossible and damage the Dust Collector.</p> <p>Check the power cables regularly as damage may have occurred while operating the machine. Always disconnect the cables before examination and treat all electrical parts with extreme care.</p>
---	---

<p>5. Inbetriebnahme und Strahlen</p> <p>Die Inbetriebnahme darf nur unter Berücksichtigung der in Kapitel 4 beschriebenen Sicherheitsregeln und Vorkehrungen erfolgen !</p> <p>Transportieren Sie die HORNET und die Absauganlage auf die abstrahlende Fläche.</p> <p>Vergewissern Sie sich, dass alle Verschleißteile in gutem Zustand sind. Alle Verschleißteile werden im Kapitel 8 definiert. Überprüfen Sie auch die elektrischen Zuleitungskabel.</p> <p>Verbinden Sie die HORNET mittels des Absaugschlauchs mit der Absauganlage. Es ist wichtig, daß der Schlauch auf ganzer Länge und an den Anschlußstücken dicht ist. Kleine Löcher oder falscher Sitz der Anschlußstücke können die Saugleistung erheblich herabsetzen.</p>	<p>5. Operating and blasting</p> <p>Operating the HORNET has to be carried out according to the safety rules in Chapter 4.</p> <p>Transport the HORNET and the Dust Collector to the floor which is to be blasted.</p> <p>Check and make sure that all wear & tear parts (defined in Chapter 8) are in good condition. If there are any doubts, replace them immediately. Check the power cables.</p> <p>Connect the HORNET with the hose to the Dust Collector. It is important, that there are no lesions or holes in the whole length of the hose. Even small holes or a wrong connection can significantly decrease the performance of the dust collector.</p>
--	---

<p>Stecken Sie die Zuleitungskabel der HORNET und der Absauganlage in die Netzsteckdosen. Das Kabel der Kugelstrahlmaschine kann mit Klebeband oder Schellen am Absaugschlauch befestigt werden. Elektrischer Anschluss siehe Kapitel 2 „Technische Daten“</p>	<p>Connect the power cables of the HORNET and the Dust Collector to the sockets. Insulation tape or similar can be used to secure the power cable to the hose. Power supply see chapter 3 “Technical Data”.</p>
<p>Kontrollieren Sie den zu strahlenden Boden auf Teile wie Schrauben, Muttern, Steine usw. und reinigen Sie die Fläche gegebenenfalls mit einem Besen oder einer Absauganlage. Leichte Hindernisse, wie Betonfugen und Absätze stellen für die Maschine kein Problem dar. Bei größeren Absätzen sollte vor dem aktivieren der Turbine geprüft werden, ob die Maschine diese Stellen problemlos überfahren kann.</p>	<p>Check the floor for screws, nuts or stones etc., and sweep the floor if necessary with a brush or a vacuum system. Small obstacles like joints pose no problems for the HORNET. If there are bigger steps or similar check if it is possible for the machine to drive over them before the turbine is switched on.</p>
<p>Bei größeren Absätzen, Fugen oder Bodenwellen ist es möglich, daß die Strahlöffnung der Maschine zu weit vom Boden abhebt. Die Dichtung der Strahlöffnung wird dann wirkungslos und Strahlmittel kann mit hoher Geschwindigkeit austreten. Es besteht Verletzungsgefahr für anwesende Personen und die Gefahr der Beschädigung von Einrichtungen. Überprüfen Sie die Fläche vor dem Abstrahlen auf solche Stellen.</p>	<p>In the case of higher steps, difficult joints or severe undulation of the floor it is possible, that the blast opening of the machine rises too far above the floor. The sealing of the Shotblaster becomes ineffective and shot escapes from the machine at high speed. This can cause injury to persons and equipment. Before operating always check the condition of the floor to prevent this from occurring.</p>
<p>Öffnen Sie den Deckel des Strahlmittelbehälters (Explosionszeichnung Nr. 89). Vergewissern Sie sich das der Dosierhebel (Explosionszeichnung Nr. 53/55) des Strahlmittelventils geschlossen ist und füllen Sie den Strahlmittelbehälter mit Strahlmittel bis zur Unterkante des Siebs auf. Strahlmittel sollte nicht bis oberhalb des Siebs aufgefüllt werden, da dann die Absauganlage diese Strahlmittel mit absaugt. Füllen Sie nur neues oder gesiebtes Strahlmittel in den Strahlmittelbehälter.</p>	<p>Open the separator lid (Appendix diagram No. 89). Make sure that the shot valve (Appendix diagram No. 53/55) is closed and pour in the shot until it reaches the level of the sieve (Appendix diagram No. 93). Do not fill above the sieve level as suction from the Dust Collector will suck it away with the dust. Only place new or clean shot in the shot compartment. Clean the sieve (Appendix diagram No. 93) in the shot compartment if it is blocked.</p>
<p>Reinigen Sie bei Bedarf das Siebblech (Explosionszeichnung Nr. 93) im Strahlmittelbehälter.</p>	<p>Switch the Dust Collector on.</p>
<p>Schalten Sie die Absauganlage ein.</p>	<p>Switch the turbine on (110V, 60Hz version Switch appendix diagram No. 131).</p>

<p>Schalten Sie den Turbinenmotor ein. (Schalter Explosionszeichnung Nr. 81)</p> <p>Öffnen Sie langsam das Strahlmittelventil mittels des Dosierhebels (Anhang Skizze Pos 53/55). Bewegen Sie die Maschine langsam vorwärts. Setzen Sie den Strahlvorgang nicht bei stehender Maschine in Gang, da Sie dann tiefe Löcher in den Boden strahlen.</p> <p>Nach einigen Metern Strahlbetrieb schließen Sie das Strahlmittelventil und stoppen dann die Kugelstrahlmaschine. Betrachten Sie das Strahlbild auf dem Boden. Bei ungleichmäßigem Strahlbild verändern Sie die Stellung der Einlaufbuchse wie im Kapitel "Einstellung und Wartung" beschrieben.</p> <p>Der Staubbehälter der Absauganlage muß bei Bedarf geleert werden. Die Leerungsintervalle sind vom Fassungsvermögen des Behälters und von der Beschaffenheit des Bodens abhängig.</p>	<p>(115/230V, 50Hz version Switch appendix diagram No. 81).</p> <p>Push the shot valve lever (Appendix diagram No. 53/55) on the right side of the handle. The HORNET will start to blast the floor. Pull or push the machine in the direction you want. If the machine stays still on one spot, it will blast a hole in the floor !</p> <p>After a few meters of blasting close the shot valve and stop the machine. Check the track on the floor. If the track is not evenly blasted, adjust the position of the shot cage as described in the 'Maintenance & Adjustment' chapter.</p> <p>The dust container of the Dust Collector has to be emptied on a regular basis. The intervals depend on the size of the container and on the condition of the floor.</p>
--	---

6. Einstellung und Wartung	6. Maintenance & Adjustments
<p>6.1 Einstellen des Strahlbildes</p> <p>Das Strahlbild wird durch Drehen der Einlaufbuchse im Strahlkasten eingestellt. Unter einem ungleichen Strahlbild versteht man, daß auf einer Seite der Strahlspur mehr abgestrahlt wird, als auf der gegenüberliegenden.</p> <p>Entfernen Sie den Einlaufschlauch (Anhang Skizze Pos 37) zwischen Strahlmittelventil und Strahlmitteleinlaufrohr. Das Strahlmitteleinlaufrohr (Anhang Skizze Pos 35) ist mittels zweier Schrauben auf dem Strahlkasten aufgespannt. Lösen Sie die beiden Schrauben. Die Einlaufbuchse (Anhang Skizze Pos 5) befindet sich unter dem Strahlmitteleinlaufrohr. Sie wird durch das Rohr in ihrer Position gehalten und ist nach dem Lösen der Schrauben drehbar.</p> <p>Wird im linken Bereich der Strahlspur mehr abgenommen als im rechten, muß die Einlaufbuchse entgegen dem Uhrzeigersinn verdreht werden und umgekehrt. Fixieren Sie die Einlaufbuchse wieder durch Festklemmen des Strahlmitteleinlaufrohrs. Bringen Sie den Einlaufschlauch an und machen Sie einen Strahlversuch. Wiederholen Sie gegebenenfalls die Einstellung, bis sich in der Strahlspur kein Unterschied im Abtrag mehr feststellen läßt.</p> <p>6.2 Verschleiß am Schleuderrad und an der Einlaufbuchse</p> <p>Das Schleuderrad (Anhang Skizze Pos 19) ist ein reines Verschleißteil und muß regelmäßig überprüft werden. Wir empfehlen die erste Überprüfung bei ca. 50 Betriebsstunden vorzunehmen. Die Lebensdauer des Rads ist abhängig vom Einsatz der Maschine. Sehr verschleißfördernd ist beispielsweise das Abstrahlen von weichen Beton mit viel Schlemme. Betonstaub ist ein sehr aggressives Medium und erhöht den Verschleiß. Verschleißarme Einsätze sind Abstrahlen von Stahl oder Aufräumen von Fliesen. Einen Wert für die Lebensdauer des</p>	<p>6.1 Adjusting the blast track</p> <p>The blasting path is adjusted by turning the shot cage (Appendix diagram No. 5) in the blast chamber (Appendix diagram No. 1). If blasting leaves an uneven path, then one side of the path is being blasted more heavily than the other.</p> <p>Remove the shot hose (Appendix diagram No. 37) situated in between shot valve and shot enter pipe. The shot cage is situated under the shot enter pipe (Appendix diagram No. 35). It is secured by two screws situated on both sides of the shot enter pipe. Loosen the screws, remove the shot enter pipe and the shot cage will turn freely.</p> <p>If the path is heavier on the left hand side compared to the right, turn the cage anti-clockwise. Turn in a clockwise direction if the path is heavier on the right hand side. Retighten the screws, fix the shot enter pipe and shot hose and try a test run. Repeat the adjustment if necessary until the path is smooth, even and without variation.</p> <p>6.2 Wear & tear on the blast wheel and shot cage</p> <p>The blast wheel (Appendix diagram No. 19) is a pure wear & tear part and must be checked regularly. CONTEC® recommend a first check after approximately 50 hours of blasting. The life time of the blast wheel depends on the application of the machine. For example a lot of wear & tear occurs when blasting soft concrete with a lot of surface fat. Concrete dust is a very aggressive substance and increases wear & tear enormously. This decreases when blasting steel or ceramic tiles. To give an accurate figure for the lifetime of the wheel</p>

<p>Schleuderrads anzugeben ist daher unmöglich. Die Lebensdauer sollte zwischen 50 und 150 Stunden liegen.</p> <p>Entfernen Sie den Strahlmittelschlauch, das Strahlmitteleinlaufrohr und die Einlaufbuchse. (Anhang Skizze Pos 37, 35 und 5).</p> <p>Vor sich sehen Sie nun das Schleuderrad (Anhang Skizze Pos 19). In der Mitte des Rads befindet sich eine Befestigungsmutter (Anhang Skizze Pos 17). Lösen Sie die Mutter durch Arretieren des Winkelschleifergetriebes und Drehen des Schleuderrades gegen den Uhrzeigersinn. Nehmen Sie das Schleuderrad aus dem Strahlkasten. Überprüfen Sie das Rad auf Verschleiß. Die Dicke der Schleuderradschaufeln sollte 3 mm nicht unterschreiten. Bei Unterschreitung kann die Schaufel brechen und das Schleuderrad zerstören.</p> <p>Die Einlaufbuchse (Anhang Skizze Pos 5) ist wie das Schleuderrad ein Verschleißteil und muss regelmäßig überprüft werden. Es können zwei verschiedene Verschleißarten an der Buchse auftreten. Das Fenster in der Buchse hat eine Breite von 30 mm. Erneuern Sie die Buchse bei einer Fensterbreite größer 33 mm. Die zweite Verschleißart besteht im Abtragen der Wandstärke. Erneuern Sie die Buchse bevor ein Loch entstanden ist.</p> <p>Ist das Rad und die Buchse in gutem Zustand, fügen Sie die Bauteile in umgekehrter Reihenfolge wieder zusammen.</p>	<p>is therefore impossible. As a rough guide, this could be anywhere between 50 and 150 hours.</p> <p>Take off the shot hose, the shot enter pipe and the shot cage (Appendix diagram No. 37, 35 and 5).</p> <p>Now the blast wheel (Appendix diagram No. 19) should be visible. In the middle of the wheel there is a nut. Loosen the nut (Appendix diagram No. 17) by locking the angle grinder gear box and turning the blast wheel against the clock. Remove the wheel from the blast chamber. Check the wear & tear on the wheel. The thickness of the five blades should not be less than 3 mm. If less, the blade could break and destroy the whole wheel. The same applies, if one of the blades is damaged or broken as a result of a foreign body entering the wheel.</p> <p>The shot cage (Appendix diagram No. 5) is like the blast wheel - a pure wear & tear part and must be checked regularly. Two different kinds of wear & tear on the cage are possible. The window in the cage has a width of 30 mm. Change the cage if this width is more than 33 mm. The second type of wear & tear is the decrease in the thickness of the cage wall itself. Change the cage before a hole appears.</p> <p>If the blast wheel and cage are in a good condition replace the parts using the opposite direction to that described above.</p>
--	---

7. Fehler und Behebung	7. Troubleshooting
<p>Der Turbinenmotor läuft nicht an.</p> <ul style="list-style-type: none"> - Ist beim Transport der Maschine der Strahlkasten voll Strahlmittel gelaufen und blockiert jetzt das Schleuderrad? - Sind die elektrischen Anschlusswerte korrekt? (230 V, 16 A) - Hat der Motorschutzschalter wegen Überlastung abgeschaltet? - Sind die Zuleitungskabel in Ordnung? <p>Die Strahlleistung ist zu gering bei laufenden Aggregaten.</p> <ul style="list-style-type: none"> - Ist das Schleuderrad verschlissen? - Ist die Einlaufbuchse korrekt eingestellt? Ist die Einlaufbuchse verschlissen? - Ist das Strahlmittelsieb (Anhang Skizze Pos 93) im Strahlmittelbehälter verstopft? - Ist das Strahlmittelventil (Anhang Skizze Pos 39) verstopft? - Ist das Strahlmittel verschlissen? (Kontrollieren Sie die Korngröße) <p>Die HORNET strahlt kurzfristig und wirft dann alles Strahlmittel wie einen Teppich aus.</p> <ul style="list-style-type: none"> - Ist das Schleuderrad verschlissen? - Ist die Einlaufbuchse richtig eingestellt? - Ist die Einlaufbuchse verschlissen? - Liegt die Bürstenabdichtung (Anhang Skizze Pos 11/13) um den Magnetrahmen satt auf dem Boden? - Ist der Boden strahlbar? Ist er trocken, nicht zu elastisch oder zu weich? 	<p>The turbine motor is not working.</p> <ul style="list-style-type: none"> - Has the blast chamber filled with shot and blocked the blast wheel during transportation of the machine? - Is the power connection correct ? (110, 115, 230V. - Is the motor overload protection tripped? - Are the cables in good condition and properly laid? <p>The blast performance is too low.</p> <ul style="list-style-type: none"> - Has the blast wheel worn out? - Has the shot cage been correctly adjusted? - Is the shot cage worn out? - Is the sieve (Appendix diagram No. 93) in the shot compartment blocked? - Is the shot valve (Appendix diagram No. 39) blocked? - Has the shot worn out (Check the size of the balls) <p>The HORNET works for a short time and then loses all the shot ('carpeting effect').</p> <ul style="list-style-type: none"> - Has the blast wheel worn out? - Has the shot cage been correctly adjusted? - Is the shot cage worn out? - Does the brush sealing (Appendix diagram No. 11/13) of the magnetic frame lie snugly with the floor? - Is it possible to blast the floor? Check the condition. Is it dry and not too elastic or soft?

8. Liste der Verschleißteile der Kugelstrahlmaschine HORNET	8. List of wear & tear parts for the HORNET
Schleuderrad Strahlmittelbuchse Strahlkasten Rückprallkanal Gummi- und Magnetleisten um die Strahlöffnung Winkelschleifer	Blast wheel Shot cage Blast chamber Reclaim chamber All sealings around the blast opening Magnetic frame Angle Grinder

9. Strahlmittel / Shot

Verschiedene Böden erfordern verschiedene Strahlmittel.

Different floors need different shot. Here is a list of shot with the fitting application.

Standard BSS 2451	Standard SAE J444a	Korngröße Shot size	Anwendung Application
S 390	S 390	1,0 - 1,7 mm	Beton und Beschichtungen Concrete and coatings
S 340	S 330	0,85 - 1,4 mm	Beton falls feines Profil gefordert Concrete with thin coatings or paint

10. Anhang

Explosionszeichnung (Skizze) / Diagram

Verdrahtungsplan / Wire diagram

Teilleiste / Part list

HORNET 230 V, 50 Hz

HORNET GB 115 V, 50 Hz

HORNET-US 110 V, 60 Hz

HORNET,
230 V, 50 Hz
115 V, 50 Hz
110 V, 60 Hz
(c) Contec GmbH 2016

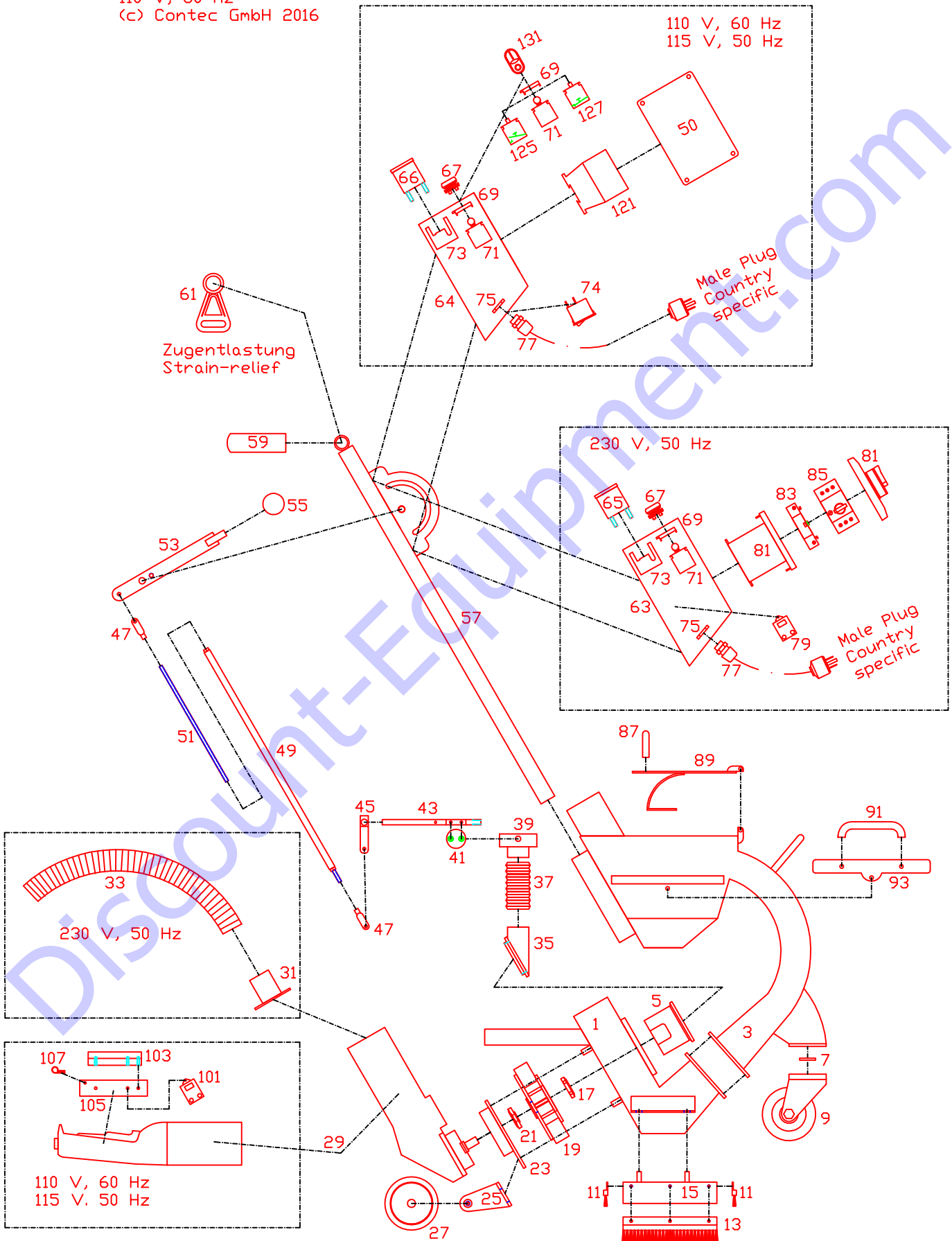

Zuleitung
230V 50Hz 10A

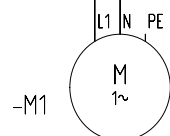
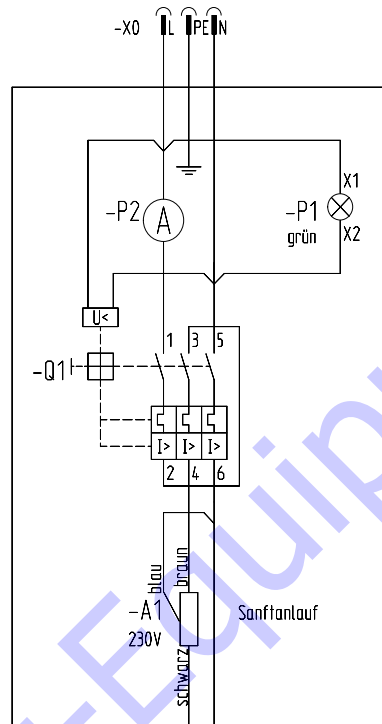

P = 2.2KW
U = 230V
I = 10A
n = 8500min-1

Discount-Equipment.com

			Datum	10.02.2016
			Bearb.	Kirchhöfer
			Gepr.	
Zustand	Anderung	Datum	Name	Norm
			Urspr.	Ers. f.
				Ers. d.



Hornet
230V 50Hz

Projekt:	=	
	+	
Projekt Nr. 00010077	Blatt 1	
Zeichnung: vpla0001.zng	von 1 Bl.	

Power supply
110/115V 50/60Hz

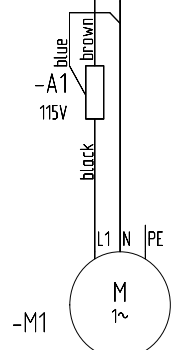
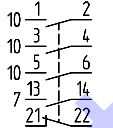
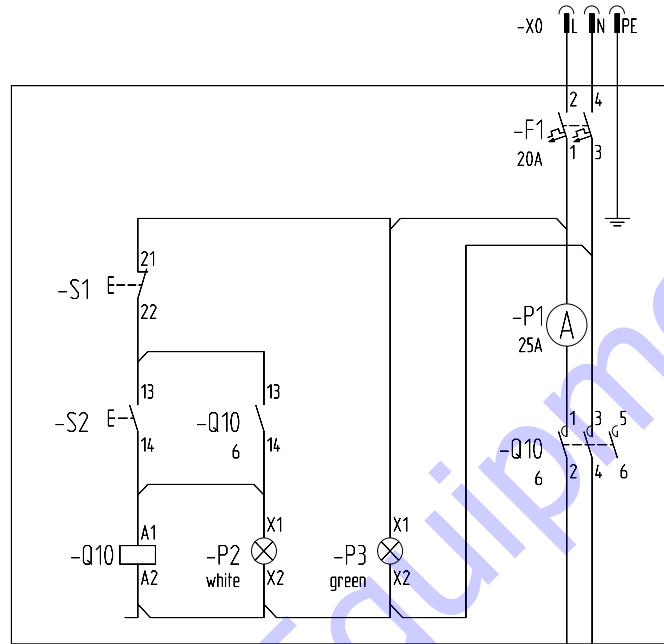

P = 2.2KW
U = 115V
I = 20A
n = 8500min-1



Hornet
110/115V 50/60Hz

Projekt:		=
Projekt Nr. 00010078		+
Zeichnung: vpla0001.zng		Blatt 1
		von 1 Bl.

Zustand	Anderung	Datum	Name	Norm	Urspr.	Ers. f.	Ers. d.

Pos.	Teilenummer Part No.	Bezeichnung	Description	Menge Quantity
001	30-12-12-00	Strahlkammer	Blast Chamber	1
003	30-12-13-00	Rückprallkanal	Reclaim Chamber	1
005	30-15-17-02	Strahlmitteleinlaufbuchse	Shot Cage	1
007	61-33-00-01	Scheibe	Washer	1
009	80-20-62-60	Hinterrad	Rear Caster	1
011	30-11-07-00	Bürste Vorne / Hinten	Brush Front / Back	2
013	30-11-07-01	Bürste Links / Rechts	Brush Left / Right	2
015	30-11-06-00	Magnetleistenrahmen	Magnetic Frame	1
017	61-32-00-01	Mutter Mitnehmer	Nut Angle Grinder	1
019	30-15-20-00	Schleuderrad	Blast Wheel	1
021	61-33-00-02	Scheibe Mitnehmer	Washer Angle Grinder	1
023	30-10-20-05	Winkelschleiferhalterung	Bracket for Angle Grinder	1
025	30-10-20-00	Hinterradaufhängung	Rear Wheel Bracket	1
027	80-20-10-40	Rad	Castor	2
029	55-03-00-32	Motor	Motor	1
031	30-15-30-00	Lüfterdeckel	Fan Cover	1
033	70-25-06-50	Lüfterschlauch	Airhose	1
035	31-10-03-00	Strahlmitteleinlaufrohr	Shot Enter Pipe	1
037	70-25-40-01	Flexrohr	Shot Hose	1
039	31-14-03-02	Strahlmittelventil Rohr mit Magneten	Shot Valve Pipe with Magnets	1
041	31-10-03-07	Strahlmittelventildeckel	Shot Valve Lid	1
043	31-10-03-06	Strahlmittelventilstange	Shot Valve Axis	1
045	31-10-03-01	Strahlmittelventilhebel	Shot Valve Lever	1
047	60-33-12-26	Gabelgelenk	Joint	2
049	30-10-03-06	Geberstange	Rod for Lever	1
051	30-10-03-08	Gewindestange	Threated Rod	1
053	30-10-03-07	Geberhebel	Lever at handle	1
055	90-21-45-12	Kugelknopf	Ball Head	1
057	30-10-05-00	Griffrohr	Handle	1
059	70-21-26-10	Griffgummi	Rubber Grip	2
061	90-20-00-24	Zugentlastung	Strain-Relief	1
063	30-10-36-00	Schaltkasten EU	Swichbox EU	1
065	51-20-30-10	Amperemeter 10 A	Ampmeter 10 A	1
067	216773	Leuchtmelder	Indicator Light	1
069	50-20-23-09	Befestigungsadapter	Mounting Adapter	1
071	50-20-33-061	LED-Element	LED Element	1
073	51-20-30-00	Abdeckung Amperemeter	Cover for Ampmeter	1
075	50-20-24-M25-MS	Gegenmutter Messing	Nut Brass	2
077	50-20-23-M25-MS	Kabelverschraubung	Cable Gland	2
079	50-20-10-19	Einschaltstrombegrenzer 230V	Power Limiter 230V	1
081	51-10-10-01	Motorschutzschaltergehäuse	Motor Protective Switch Box	1
083	51-20-30-04	Unterspannungsauslöser	Low Voltage Protective	1
085	51-20-30-01	Motorschutzschalter	Motor Protective	1
087	90-21-50-16	Bügelgriff	Handle	1
089	30-11-10-00	Strahlmittelbehälterdeckel	Shot Compartment Lit	1
091	90-21-50-17	Bügelgriff schräg	Handle inclined	1
093	30-10-01-01	Sieb	Sieve	1

Discount Equipment

Discount-Equipment.com is your online resource for commercial and industrial quality parts and equipment sales.

Locations:

Florida (West Palm Beach): [561-964-4949](tel:561-964-4949)

Outside Florida TOLL FREE: [877-690-3101](tel:877-690-3101)

Need parts? Check out our website at www.discount-equipment.com

Can't find what you need?

Click on this link: <http://www.discount-equipment.com/category/5443-parts/> and fill out the request form.

Please have the machine model and serial number available in order to help us get you the correct parts. One of our experienced staff members will get back to you with a quote for the right part that your machine needs.

We sell worldwide for the brands: Genie, Terex, JLG, MultiQuip, Mayco, Toro/Stone, Diamond Products, Magnum, Airman, Mustang, Power Blanket, Nifty Lift, Atlas Copco, Chicago Pneumatic, Allmand Brothers, Essick, Miller Spreader, Skyjack, Lull, Skytrak, Tsurumi, Husquvarna/Target, Whiteman-Concrete/Mortar, Stow-Concrete/Mortar, Baldor, Wacker, Sakai, Snorkel, Upright, Mi-T-M, Sullair, Neal, Basic, Dynapac, MBW, Weber, Bartell, Bennar Newman, Haulotte, Ditch Runner, Blaw-Knox, Himoina, Best, Buddy, Crown, Edco, Wyco, Bomag, Laymor, Terremite, Barreto, EZ Trench, Takeuchi, Basic, Bil-Jax, Curtis, Gehl, Heli, Honda, ICS/PowerGrit, Puckett, Waldon, ASV, IHI, Partner, Imer, Clipper, MMD, Koshin, Rice, Gorman Rupp, CH&E, Cat Pumps, Comet, General Pump, Giant, AMida, Coleman, NAC, Gradall, Square Shooter, Kent, Stanley, Tamco, Toku, Hatz, Kohler, Robin, Wisconsin, Northrock, Oztec, Toker TK, Rol-Air, Small Line, Wanco, Yanmar

New Equipment - Used Equipment - Rental Equipment - Parts and Accessories

Discount Equipment

www.discount-equipment.com

561-964-4949

Parts: wbparts@Discount-Equipment.com

Sales: info@Discount-Equipment.com