

WALDON

*DURABLE PRODUCTS . . .
DEPENDABLE PEOPLE*

SWEEPMASTER 250

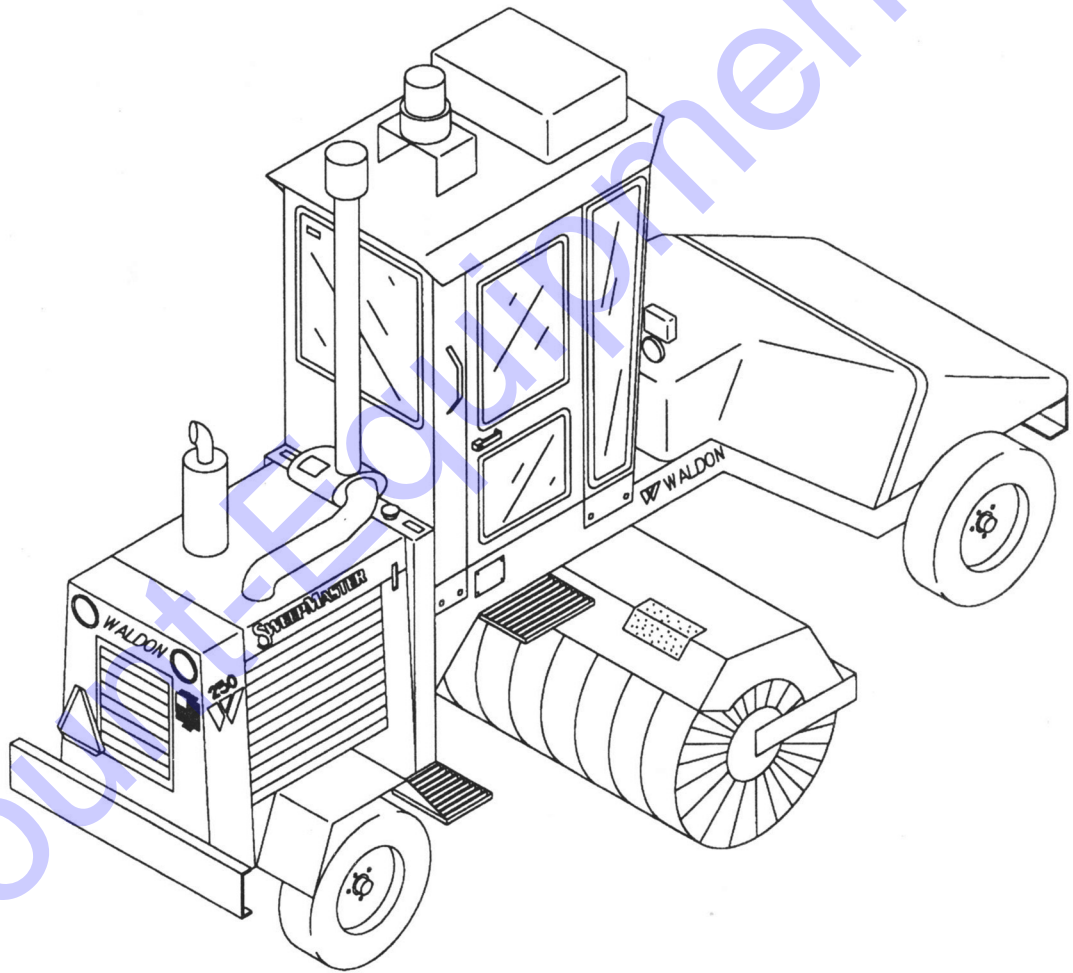

OPERATOR'S MANUAL



P/N 357301-REV. 10-00

www.discount-equipment.com

Discount Equipment

Discount-Equipment.com is your online resource for commercial and industrial quality parts and equipment sales.

Locations:

Florida (West Palm Beach): [561-964-4949](tel:561-964-4949)

Outside Florida TOLL FREE: [877-690-3101](tel:877-690-3101)

Need parts? Check out our website at www.discount-equipment.com

Can't find what you need?

Click on this link: <http://www.discount-equipment.com/category/5443-parts/> and fill out the request form.

Please have the machine model and serial number available in order to help us get you the correct parts. One of our experienced staff members will get back to you with a quote for the right part that your machine needs.

We sell worldwide for the brands: Genie, Terex, JLG, MultiQuip, Mayco, Toro/Stone, Diamond Products, Magnum, Airman, Mustang, Power Blanket, Nifty Lift, Atlas Copco, Chicago Pneumatic, Allmand Brothers, Essick, Miller Spreader, Skyjack, Lull, Skytrak, Tsurumi, Husquvarna/Target, Whiteman-Concrete/Mortar, Stow-Concrete/Mortar, Baldor, Wacker, Sakai, Snorkel, Upright, Mi-T-M, Sullair, Neal, Basic, Dynapac, MBW, Weber, Bartell, Bennar Newman, Haulotte, Ditch Runner, Blaw-Knox, Himoina, Best, Buddy, Crown, Edco, Wyco, Bomag, Laymor, Terremite, Barreto, EZ Trench, Takeuchi, Basic, Bil-Jax, Curtis, Gehl, Heli, Honda, ICS/PowerGrit, Puckett, Waldon, ASV, IHI, Partner, Imer, Clipper, MMD, Koshin, Rice, Gorman Rupp, CH&E, Cat Pumps, Comet, General Pump, Giant, AMida, Coleman, NAC, Gradall, Square Shooter, Kent, Stanley, Tamco, Toku, Hatz, Kohler, Robin, Wisconsin, Northrock, Oztec, Toker TK, Rol-Air, Small Line, Wanco, Yanmar

New Equipment - Used Equipment - Rental Equipment - Parts and Accessories

Discount Equipment

www.discount-equipment.com

561-964-4949

Parts: wbparts@Discount-Equipment.com

Sales: info@Discount-Equipment.com

Warranty Mobile Products, Inc.

1. **What is Covered By This Warranty.** Mobile products, Inc. (Mobile) warrants, to the original purchaser only that the equipment that is the subject of this sale is free from defects in material and workmanship. The duration of this warranty is one year from the date of delivery or 1000 hours of use, whichever comes first. If the purchaser discovers within the applicable period a defect in material or workmanship, it must promptly notify Mobile in writing. In any event such notification shall be received by Mobile no later than 13 months from the date of delivery or one month after the first 1000 hours of use, whichever comes first. Within a reasonable time after such notification, Mobile will correct any defect in material or workmanship, with either new or used replacement parts, at Mobile's option. Mobile will pay for the costs of correcting defects in materials or workmanship of all parts and components manufactured by Mobile discovered during the first 12 months from the date of delivery or the first 1000 hours of use, whichever comes first, both parts and labor at Mobile's expense. All warranty work is subject to Mobile's prior examination and approval and will be performed by Mobile or at service centers designated by Mobile. All transportation to and from the designated service center will be at the purchaser's expense and is not included as a cost of repair covered by this warranty. These remedies are the purchaser's exclusive remedies for breach of warranty.
2. **What is Not Covered By This Warranty.** Mobile does not warrant (a) any product, components or parts not manufactured by Mobile, (b) damage caused by use of the equipment for purposes other than those for which it was designed, (c) damage caused by accident or the negligence of the purchaser or any third party or by disasters such as fire, flood, wind and lightning, (d) damage caused by the purchaser's failure to provide normal maintenance as customarily accepted in the industry or as set forth in maintenance guidelines, (e) filters, belts, lubricants, fuses, lights or other parts which are a part of normal maintenance replacement, (f) damage caused by unauthorized or improper installation of attachments, repairs, modifications or alterations, (g) damages caused by replacement of original parts or components with unauthorized substitutes, (h) damage during shipment, or (i) any other abuse or misuse by the purchaser.
3. **Disclaimer of Warranty.** THE FOREGOING WARRANTIES ARE IN LIEU OF ALL OTHER WARRANTIES, EXPRESS OR IMPLIED, INCLUDING BUT NOT LIMITED TO THE IMPLIED WARRANTIES OF MERCHANTABILITY AND FITNESS FOR A PARTICULAR PURPOSE.
4. **Limitation of Remedies.** In no case shall Mobile be liable for any special, incidental, or consequential damages based upon breach of warranty, breach of contract, negligence, strict tort, or any other legal theory. Such damages include, but are not limited to, loss of profits, loss of savings or revenue, loss of use of the equipment or any associated equipment, cost of capital, cost of any substitute equipment, equipment, facilities or services, downtime, the claims of third parties including customers, and injury to property. This limitation does not apply to claims for personal injury. Some states do not allow limits on warranties, or on remedies for breach in certain transactions. In such states, the limits in this paragraph and in paragraph (3) may not apply.
5. **Warranty Claim Procedures.** The purchaser must notify Mobile in writing of a warranty claim prior to any warranty work. Mobile will provide the purchaser with further instructions on how to proceed with such warranty claim. Any notice of a warranty claim and all other warranty correspondence must be sent to Mobile Products, Inc. 401 Capacity Drive, Longview, TX 75604. Mobile may designate new or additional addresses.
6. **Time Limit for Bringing Suit.** Any action for breach of warranty as to any part or component must be commenced within 15 months following delivery of the equipment or within the first three months following the first 1000 hours of use, whichever comes first.
7. **No Other Warranties.** Unless modified in a writing signed by both parties, this agreement is understood to be the complete and exclusive agreement between the parties, superseding all prior agreements, oral or written, and all other communications between the parties (including without limitation any terms and conditions contained in any purchase order or sales invoice issued pursuant to the sale of this equipment) relating to the subject matter of this agreement. No employee of Mobile or any other party is authorized to make any warranty in addition to those made in this agreement.
8. **Warranty Registration.** This warranty is conditioned upon receipt by Mobile of a completed and signed customer acceptance card within 30 days of delivery. It is the obligation of the purchaser to sign customer acceptance card and return it to Mobile within the 30 days following delivery. The customer acceptance card must be on file for any warranty claim to be considered.

TO OUR CUSTOMERS

This Operator's Manual provides you with the necessary information for the proper operation, lubrication and maintenance for your Waldon Sweeper.

We especially call your attention to the section on "SAFETY". Although your sweeper is designed with the safety of the operator in mind, accidents can still happen. Therefore, UNDERSTAND YOUR SWEEPER AND PRACTICE ALL SAFETY PRECAUTIONS.

Remember, service to your sweeper can save costly repairs and valuable time loss because of breakdown. Replacement parts for your sweeper can be obtained through your dealer. When ordering parts, be sure to give the SERIAL and MODEL NUMBER of your sweeper. Record the Sweeper and Engine Serial Numbers in spaces below so they are readily available when you need them.

Should the Serial No. Plate located on the right hand Main Frame Channel should ever be lost, the S/N is also stamped into the top side of 6" Channel right in front of the R.H. Rear Fender.

We are happy to have you as an owner of a Waldon Sweeper and trust it will serve you well for the purpose for which it was purchased. Should you need assistance, contact your Dealer or Distributor.

SWEEPER SERIAL NO. _____

ENGINE SERIAL NO. _____

TABLE OF CONTENTS

SPECIFICATIONS

SECTION 1

SAFETY INSTRUCTIONS

SECTION 2

OPERATION

SECTION 3

LUBRICATION

SECTION 4

PERIODIC MAINTENANCE

SECTION 5

Discount-Equipment.com

SWEEPMASTER SPECIFICATIONS

SECTION 1

ENGINE OPTIONS

Description Engine	HP.@2500 RPM	Max Torque	Displacement	No. of Cyl.
4B3.9 Cummins Diesel	76	184 Lb. Ft. @ 1200 RPM	239.3	4
4039 John Deere	80	195 Lb. Ft. @ 1400 RPM	239	4

Maximum Engine RPM 2500

HYDRAULIC SYSTEM

Wheel Drive Pump-Piston Type 37.8 G.P.M @ 2500 RPM
(3.5 Cu. in./Rev.) Max. Pressure 5000 PSI
Wheel Motor-Piston Type, 3.50, Max. 2.0 Min. cu. in./Rev.
Wheel Drive-Dana Axle Model 44 3.73-1 Ratio
Broom Drive Lift, Angle and Steering Pump-Gear Type,
25 GPM @ 2500 RPM (2.32 cu. in./Rev.)
Broom Drive Motor-Geroler Type 18.6 cu. in./Rev.
Broom Drive, Lift and Angle Valve, 2400 PSI
Steering Unit-4 GPM Priority, 1600 PSI
Filter-7 Micron In-line Charge System
Filter-10 Micron Oil Return Line

SWEEPER DIMENSIONS

Wheel Base	137.25"
Tread Width Outside to Outside of Tire	67.00"
Overall Length	190.00"
Overall Height to Top of ROPS Canopy	105.00"
Overall Width (with broom straight)	100.00"
(with broom angled 45°)	87.25"
Turning Radius Outside	21'

SWEEPER CHARACTERISTICS

Ground Travel Speed	Low Range 0-12.0 MPH High Range 0-25 MPH
Broom Rotation Speed	250 RPM
Broom Angle	45° Right or Left
Max Gradeability	Low Range @5000 PSI 45% High Range @5000 PSI 15%
Fuel Tank Capacity	20 Gal.
Hydraulic Oil Reservoir Capacity	20 Gal.
Engine Coolant Capacity	4.5 Gal.
Axle Differential Capacity	3.0 Pints
Gear Reduction Box Capacity	2.0 Pints
Steering	Power Assist
Service Brakes	Front Drum (Optional) Rear Drum

SWEeper CHARACTERISTICS CONT'D

Parking Brakes	Rear	Mechanical
Front Axle		Full Oscillating 18° Total
Air Cleaner		Heavy-Duty Dry Element with Back-up Safety Element
Tires		ST225/75R15 6-Ply
Tire Pressure		45 PSI

BROOM

Direct, Hydraulic drive enclosed in broom core, Full cover over 160° of broom with end plates.
Full 45° Power Angling left or right, Swing frame mounted on large 2.5 DIA Pin.

Standard Core is wafer type polypropylene filled (wire or 1/2 wire and 1/2 poly available). Core Assembly is steel, 8 feet long (243.8cm) with 7 ft. 6 in. (228.6cm) sweeping surface.

INSTRUMENTS AND CONTROLS

Hour Meter, Fuel, Oil Pressure, Ammeter, Engine Water Temperature, Hydraulic Oil Temperature, Engine Throttle Forward & Reverse, Low & High Range, Broom Lower or Raise, Left & Right Angle, Parking Brake, Horn, and Reverse Alarm

SHIPPING AND OPERATING WEIGHT

Complete with ROPS Canopy	4600 lbs.
Complete with ROPS Cab and Air Cond.	5200 lbs.
150 Gal. Water Tank and System	200 lbs.
150 Gal. Water Will Weigh	1250 lbs.

OPTIONAL EQUIPMENT

All Steel ROPS Pressurized Cab, One Door
Engine Turbo II Pre-Cleaner
Windshield Wiper
Rear Window Wiper
Canopy Windshield
Strobe Light
Air Conditioner
Heater
Sprinkler System
Steel Wire Brush
1/2 Poly, 1/2 Steel Brush
Front Bumper Kit
Rear Bumper Kit
Rear View Mirror Kit
Low Profile Water Tank Kit
Debris Shield Kit
Engine Compartment Doors

OPTIONAL EQUIPMENT CONT'D.

Ether Cold Start Aid (Cummins)
Audible Alarm & Warning Light
Radiator Lock
Light Kit
Block Heater (Cummins)
Spare Tire & Wheel
Tachometer
Front Wheel Brakes Drum Type

Discount-Equipment.com

SAFETY INSTRUCTIONS

SECTION 2

1. **WARNING** - Before using the sweeper, study these **SAFETY MESSAGES**. Read all safety signs on the sweeper. Learn and practice safe use of all controls before operating the sweeper under a load.

It is your responsibility to observe all pertinent laws and regulations regarding the operation of the sweeper.

2. Allow only responsible persons to operate the sweeper.
3. Keep all hydraulic lines and pipes in good condition. A stream of hydraulic oil can penetrate the skin and cause injury as well as possibly causing blood poisoning.
4. Securely fasten your seat belt. It can help secure your safety if it is used and maintained. Never allow slack in the belt system while in use.
5. Do not operate any of the controls unless seated in the operator's seat.
6. Never permit anyone to smoke, light matches, or make adjustments on electrical system while refueling.
7. Never refuel while engine is hot or running.
8. Always use extra care when operating on steep grades, banks or hillsides. In road travel, never drive too close to the edge of a ditch. Watch for holes into which a wheel might drop and cause machine to overturn.
9. Do not oil, grease or adjust machine with engine running.
10. Always use warning lamps or flags when driving on roadways.
11. Engage parking brake before dismounting sweeper.

SAFETY INSTRUCTIONS

OPTIONAL TOW PACKAGE

1. Check local, state, and federal regulations to ensure towed and towing vehicle meet necessary requirements.
2. Check tow vehicle's manufacturers recommendations for proper equipment.

The towing vehicle must have a trailer weight capacity of 6,000 lbs. or higher and be equipped with a Class 4 coupler.

TOWING THE SWEEPMASTER "250" WITH OPTION TOW PACKAGE

1. Drain water from sprinkler tank.
2. Set Parking Brake and disengage axle disconnect by pushing down on "T" Handle and locking in place.
3. Connect unit to tow vehicle and attach safety chains and lights.
4. Check operation of lights.
5. Release Parking Brake on sweeper before towing unit.

DO NOT TOW UNIT OVER 55 MPH.

Note: Some tire skidding may occur during slow speed sharp turns. The sweeper is equipped with a special open center steering orbital to reduce skidding as much as possible.

To place sweeper back into service:

1. Set Parking Brake.
2. Disconnect unit from tow vehicle. Raise and lock hitch with lock pin provided.
3. Engage the axle disconnect by unlocking "T" Handle and pulling cable up and locking into place.
4. To aid in spline alignment the ground drive may be engaged slightly.

OPERATION SECTION 3

CHECKING SWEEPER

Before placing your new sweeper in operation, thoroughly familiarize yourself with it. Check oil level in crankcase, hydraulic system and check tires for proper inflation as specified in Section I. Go through this manual and follow along with a visual examination of corresponding sweeper components. Make certain the function of each control and instrument is thoroughly understood before operating your new sweeper.

STARTING AND BRAKING-IN NEW ENGINE

Careful breaking-in of a new engine will greatly increase its life. Use the Engine Operator's Manual that is sent with every sweeper to determine the proper break-in procedure.

TOWING THE SWEEPER WITHOUT OPTIONAL TOW PACKAGE

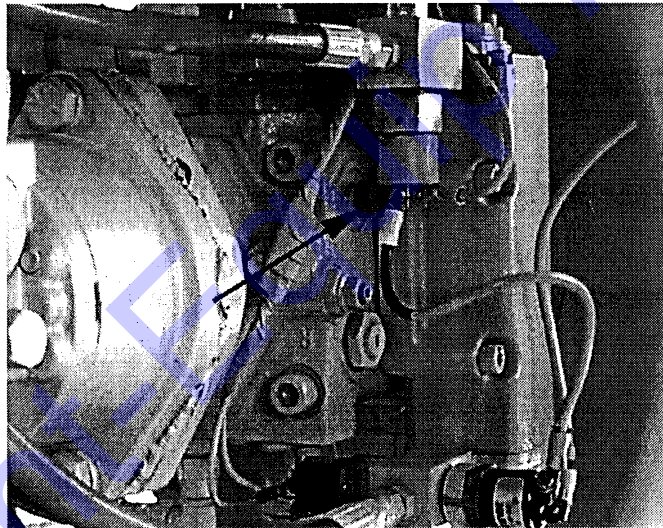

In case of engine or drive failure, set the Parking Brake and disconnect the hydrostatic pump by turning the tow valve (located on the side of the pump) counterclockwise 2 turns.

This is for service reasons only, towing the unit will cause the hydrostatic drive motor to circulate oil (acting as a pump). The tow valve allows the oil to circulate without turning the pump. Extended towing will damage the hydrostatic motor.

CAUTION

Waldon does not recommend towing sweeper from one job site to another, unless properly equipped with the optional Tow Package.

OPERATING INSTRUCTIONS

BEFORE ATTEMPTING TO OPERATE THE EQUIPMENT READ THESE INSTRUCTIONS COMPLETELY. IF YOU HAVE ANY QUESTIONS CONCERNING SAFETY OF OPERATION CONTACT YOUR DEALER OR WALDON, INC.

YOUR MACHINE CONSISTS OF THE FOLLOWING CONTROLS:

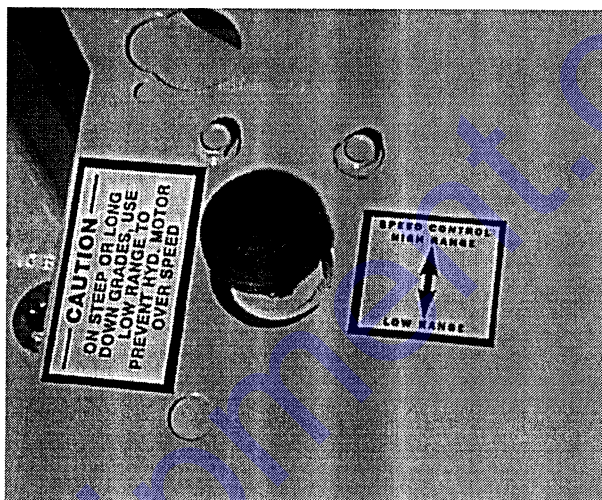

1. **THROTTLE CONTROL CABLE** - This cable is located on the top right hand side of the control console. It's purpose is to control the speed of the engine. Depress button in center of control cable and pull knob to increase speed. Twisting the knob will give fine adjustment of throttle setting. To decrease engine RPM depress button and push knob all the way in.
2. **DIRECTIONAL CONTROL FOOT PEDAL** - These pedals are located to the right of the console. Depress the inside pedal for forward travel and the outside pedal for reverse. The pedals control the pilot oil used to stroke the hydrostatic transmission pump. The further the pedal is depressed the faster the sweeper will travel. Gradually press and release pedals do not stomp pedals, always allow unit to stop completely before changing travel direction. To stop unit, release direction control pedals and apply Service Brake.
3. **TWO SPEED SHIFTER CONTROL** - This control is located to the right and rear of the operators seat. It has two speeds to select from. High range, when the knob is pulled up, is used when driving the sweeper from one job site to another. Low range, when the knob is pushed down, is for actual operating of the machine when sweeping. Do not sweep in high range this can cause the Hydrostatic System to run hot.

CAUTION

Avoid shifting from one range to another (High or Low) without throttling Engine RPM back approximately to half engine speed

4. **BRAKE PEDAL** - This pedal is located to the left of the control console. In most cases the hydrostatic controls will stop the machine, but when working on grades the brake pedal will be necessary.
5. **PARKING BRAKE LEVER** - The parking brake lever is located to the right of the operator.
6. **INSTRUMENT PANEL** - The instrument panel contains the following gauges:

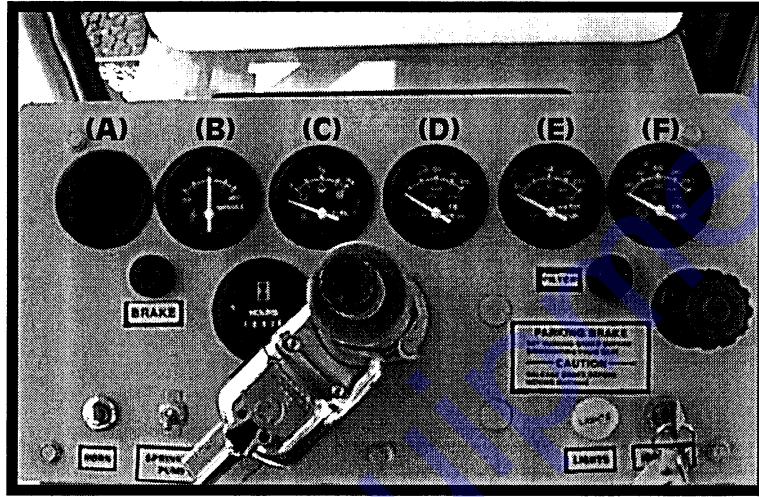

- | | | | |
|----|-----------------------|----|----------------------------|
| A. | Tachometer (Optional) | D. | Hydraulic Oil Temperature |
| B. | Amp. | E. | Engine Coolant Temperature |
| C. | Fuel | F. | Engine Oil Pressure |
7. **BROOM CONTROL VALVE** - This valve is located on the seat mount to the right of the operator. It consists of 3 spools which control the following:
 - A. **SWING CYLINDER CONTROL** - This is the handle closest to the operator. When you push the handle forward the broom will swing to the left. When you pull the handle back the broom swings to the right. When you have achieved the position desired, release the handle and it will return to center locking the broom in position.
 - B. **LIFT CYLINDER CONTROL** - This is the center handle. When the lever is pushed forward the broom will lower. When pulled back it will raise. When lever is in max forward (float position) broom will float with contour of the ground. To obtain a 3" to 5" sweep pattern (without broom rotating) drop broom down till broom just makes contact with surface to be swept. Let control lever spring back to center position and engage broom rotation. This will hold broom in this position and should result in a 3" to 5" sweep pattern.

If more sweep pattern is desired then let just a little more weight settle on broom before letting handle spring back to center position.

- C. **BROOM DRIVE MOTOR** - This is the outside control handle on the valve. This controls the forward (or optional backward) rotation of the broom. When sweeping forward the handle should be in the forward position.

CAUTION

Broom motion must stop before changing from forward to backward rotation or broom motor shaft could fail.

8. **OPTIONAL - BROOM COUNTER BALANCE VALVE** - This is located at the seat mount to the right and rear of the operator seat. It's purpose is to maintain the broom in the position that it was set. To set broom counter balance valve, start broom rotating at full speed with the parking brake on, lower broom on surface to be swept, be sure lift cylinder valve is in detent position. Raise broom and observe, the broom pattern left on the surface. If pattern is more than 3 to 5 inches, increase the adjustment until pattern is not more than 3 to 5 inches. For heavy dirt conditions see page 4-6.

It is a common thought that the more pressure the broom puts on the surface the better it sweeps. This is WRONG. Excessive pressure does a poor sweeping job and rapidly wears out the broom. It is the flicking action of the broom that does the sweeping. Should there be an excessive amount of material to be moved, blade off the excess, then sweep.

This valve controls the broom sweep pattern.

If the pattern is more than 3 to 5 inches, turn the adjustment knob clockwise to decrease the pattern. If the pattern is less than 3 to 5 inches, turn the adjustment knob counterclockwise to increase the pattern. After the proper sweep pattern has been established lock the adjustment knob with the jam nut on the control.

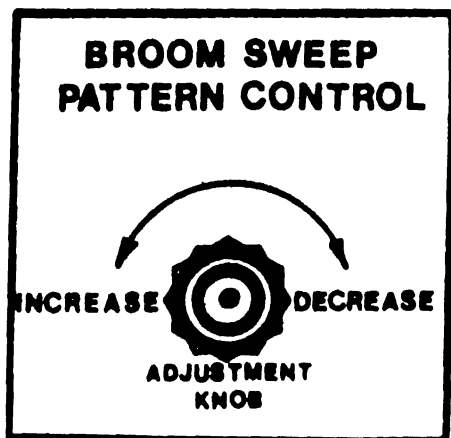

Now that you are familiar with your controls you are ready to operate the machine. Operating procedures are as follows:

1. OPERATOR MUST BE IN SEAT WHEN THE ENGINE IS RUNNING

2. TO START ENGINE:

- A. Directional Control Pedals must be in the neutral position. (both pedals up)
- B. Set Parking Brake
- C. To start the engine under normal weather conditions, pull the throttle control to approximately 1/4 open position and turn ignition starter switch to extreme right. Do not operate starter for more than 30 seconds at a time. If after three attempts the engine fails to start, determine cause and correct the failure. Do not attempt to start engine by towing. This sweeper is hydrostatically driven and cannot be started by towing.

3. DRIVING THE SWEEPER AND ADJUSTING BROOM SPEED

To drive the sweeper, low range is used for working speeds while sweeping. High range is used for moving from one job site to another.

- A. Select working range.
- B. Release Parking Brake.
- C. Slowly move Broom Control Lever forward.
- D. Increase RPM of engine.
- E. Adjust broom speed by increasing or decreasing throttle setting.
- F. Depress the inside control pedal slowly to go forward. The outside pedal to go in reverse.
- G. Adjust travel speed by further depressing or releasing of control pedal.

CAUTION

- 4. AVOID SUDDEN REVERSING. COME TO A COMPLETE STOP BEFORE SHIFTING BETWEEN FORWARD AND REVERSE.
- 5. CHECK ALL GAUGES AFTER ENGINE IS WARM.
- 6. PARKING BRAKE MUST BE SET WHEN OPERATOR IS OUT OF SEAT OR MACHINE WILL ROLL.

OPERATING RECOMMENDATIONS

It is not possible for us to be present when each new Waldon broom is placed in operation for the first time. We submit here some helpful suggestions as reported by the drivers of sweepers equipped with various brooms, as well as ideas we have picked up during our years of experience in this field.

There is an infinite variety of sweeping conditions. We can only give you general principles to follow:

LEAVES, AVERAGE STREETS, AVERAGE DIRT CONDITIONS

A 3" to 5" sweeping pattern will give best results. (See Illus. "D") as you know, leaf carryover is a problem with all types of brooms. The only solution is to slow down the forward movement until the broom can handle the leaves.

If the broom is worn to a small diameter, this condition will be accelerated.

HEAVY DIRT CONDITIONS

Slow the forward movement of the sweeper between 3 and 5 miles per hour and speed up the RPM for the broom. It is more economical to make a quick second pass in small areas of heavy dirt concentration than to keep the broom adjusted with too large a pattern. If you are working totally in heavy dirt, you may want to adjust your broom to 7" to 8" sweeping pattern. We have not seen a condition where patterns in excess of 8" improve the performance of any broom.

The greater the sweeping pattern, the faster the broom wear. A pattern in excess of 8" causes the broom filaments to press the dirt into the ground, rather than to get behind it and pick it up. (See Illus. "E")

HILLSIDE STREETS

Hillside streets with high crown, deep gutters, broken pavement and chuckholes present the worst condition. Dirt gravitates to the lowest spot. To reach it the broom pattern may have to be temporarily disregarded. Immediately after sweeping such areas the sweeping pattern should be reestablished.

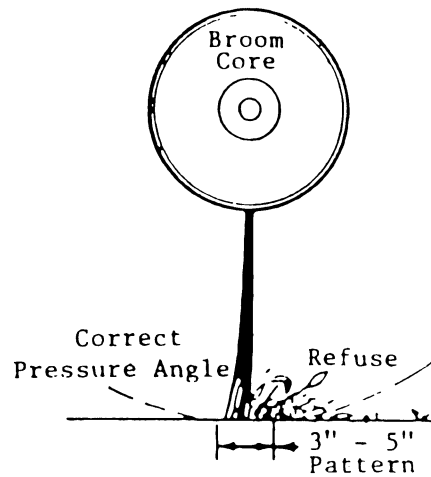

CORRECT BROOM SETTING (Illus. "D") - A light broom pressure on the pavement cleans better as it lets the broom fibers get behind the refuse and pick it up. It also sweeps a rough surface cleaner, brooms last longer and sweeper maintenance is reduced.

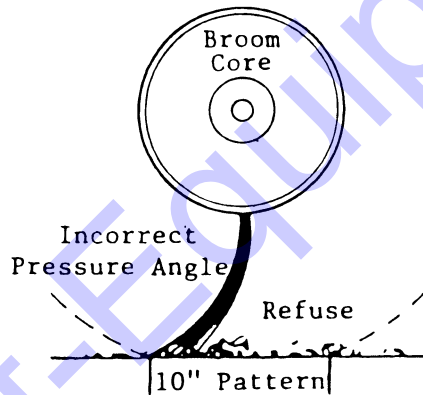

INCORRECT BROOM SETTING (Illus. "E") - Rubs the refuse into the pavement. Results in excessive broom wear, a poor sweeping job and places unnecessary strain on all sweeper mechanisms.

LUBRICATION

SECTION 4

CHECKING HYDRAULIC FLUID

Check fluid level daily or every eight hours of operation and replenish if necessary to maintain full.

After the first 20 hours of operation replace both charge and return oil filter, then change filters every 250 hours thereafter.

Drain Hydraulic Oil every 500 hours of operation or one year whichever comes first.

HYDRAULIC FLUID RECOMMENDATIONS AND SERVICING

In choosing an oil for the hydraulic system of your Waldon sweeper, consideration must be given to the temperature range at which the oil will be working and the actual application as it exists. The oil that is recommended has been chosen because of its operating temperature range for hot or cold conditions to best fit the needs of the various component parts of your sweeper.

To best fit the needs of all hydraulic components, we recommend the use of 10W-20 hydraulic fluid or equivalent. We recommend the following viscosity grades based on Ambient temperatures.

<u>Viscosity Grade</u>	<u>Ambient Temp.</u>	<u>Max. Hyd. Oil Temp.</u>
ISO 32	0 - 50° F	140° F
ISO 46	15° - 110° F	170° F
ISO 68	50° - 110° F	200° F

See Service Bulletin No. 11-35 for specific oil information.

All parts of the complete hydraulic system are lubricated by the hydraulic oil in the circuit. Particular attention must be paid to keep oil in the hydraulic system clean.

CHASSIS LUBRICATION

Lubricate all lube fittings every 8 hours of operation. Check wheel bearing periodically, and repack if necessary. See chart on page 4-2.

LUBRICATION

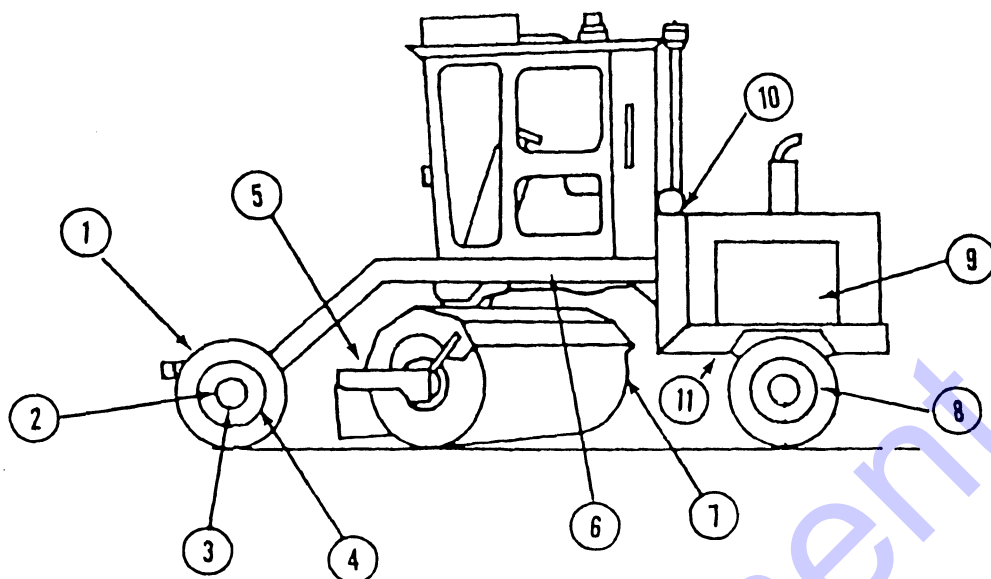

ITEM	NO. OF POINTS	DESCRIPTION	TYPE OF LUBRICATION	FREQUENCY
1	1	Axle Oscillation	GR	40 HRS
2	2	King Pins	GR	8 HRS
3	2	Wheel Spindles	GR	500 HRS
4	3	Tie Rod Ends	GR	8 HRS
5	1	Broom Lift	GR	8 HRS
6	1	Broom Swing	GR	8 HRS
7	1	Pillow Block Bearing	GR	8 HRS
8	1	Rear Axle	90W	1st-100 HRS thereafter 1000 HRS
9	1	Engine Oil	EO	check 8 HRS
10	1	Hydraulic Reservoir	HO	check 8 HRS
11	1	Gear Reduction Box	SG	1st-100 HRS thereafter 1000 HRS

GR - Multipurpose Extreme Pressure Grease

90W- SAE 90 Weight API GL5

EO - Engine Oil (Consult Engine Manual)

HO - Hydraulic Oil (See Page 4-1)

SG - Synthetic Gear Lube Mobil Lube SHC 75W-90 or equivalent
Lubricant meeting API Service GL-S and MIL-L 2105D

PERIODIC MAINTENANCE

SECTION 5

DRY ELEMENT AIR CLEANER

The air cleaner is designed to give maximum engine protection with a minimum of parts. Maintenance costs are low because the service parts of the air cleaner are few and easily serviced. Use only Donaldson Duralife filter cartridges. They are designed for maximum performance with simplicity of operation and maintenance. Dust is removed by centrifugal cleaning and is carried into the dust cup which is easily and quickly removed and dumped. Under ordinary dust conditions, dust cup service is required only infrequently.

TO SERVICE AIR CLEANER

1. Stop engine before removing element (otherwise dirt will be drawn into engine).
2. Loosen cover wing nut and remove element from body. Remove safety element. Clean inside of body and cover. The plastic pre-cleaning fins on element are not removable.
3. Clean the element by the following method. Direct compressed air of not more than 80 PSI up and down the pleats inside the element.
4. Inspect element by placing light inside and inspect for thin spots, pin holes, or slightest ruptures which call for replacement. Do not leave light inside element any longer than necessary as heat generated by the bulb may ruin element. Do not try to clean the safety element. Change the safety element every third filter change.
5. Replace the safety element and wing nut. Replace the element and cover. Then finger tighten the retaining wing nut securely. Do not tighten with pliers or a wrench.

FUEL FILTER (DIESEL)

For instructions on replacement of fuel filter and instructions for bleeding filter, see the engine manual.

Clean fuel water trap as specified in Engine Manual.

IN-LINE FUEL FILTER

Change the fuel filter after every 500 hours. If sweeper has loss of power, the fuel filter may be clogged before time to change.

REAR DRUM BRAKES

Brake shoes are self adjusting so no maintenance should be required until shoes need replacing.

REPLACING BROOM

To remove Broom Core Assembly from the sweeper, lower the broom to the ground. Remove the 1/2" bolts that fasten the broom motor mount to the frame. Remove the 1/2" nuts from the bearing on the right hand broom arm. Broom core will now be free, lift broom frame using broom lift control lever. Slide broom drive motor out of core. Do not remove hoses from the motor. Slide broom core out from under machine. For wafer removal and remounting see page 5-5. To reinstall refilled core, slide core back under broom frame. Reinstall broom drive motor, making sure male coupler is fully engaged into female coupler. Lower broom frame, align bolt holes on broom motor side, install capscrews, finger tight. Attach pillow block bearing to the broom arm studs and tighten nuts securely.

NOTE

Removal of Pillow Block Bearings from the broom core is sometimes required.

If the bearing must be removed reinstall any spacers/collars in the proper position before attaching bearing to the broom arm. Secure setscrew on bearing then tighten broom motor mount capscrews securely.

INSTALLATION PROCEDURES FOR WAFER BRUSHES

1. Remove the R.H. Broom Core Cap

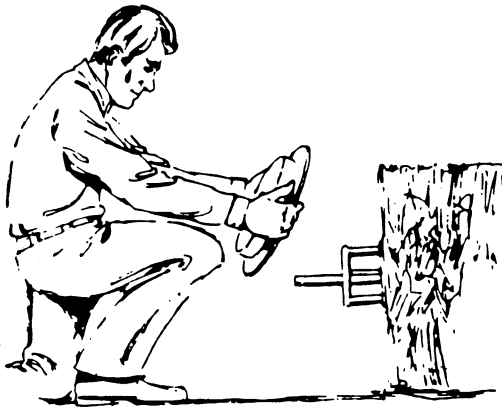

2. Stand core on end with remaining flange end down.



3. Slide wafers off of core.
NOTE: Wafers may need to be cut off with a torch. Do not save spacers.

4. **MOUNTING WAFERS** - Please note "LUG" or lapping part of wafer. Make sure these lugs are turned alternately as they are placed on core (12, 4 & 8 o'clock). This is similar to balancing tires. Spacers fit between each wafer.

NOTE: With convoluted or (spacerless) wafers. Every other wafer must be flipped over and placed on the core in the opposite direction of the proceeding wafer. This prevents the wafers from nesting together and allows the convolutions to properly space the wafers.

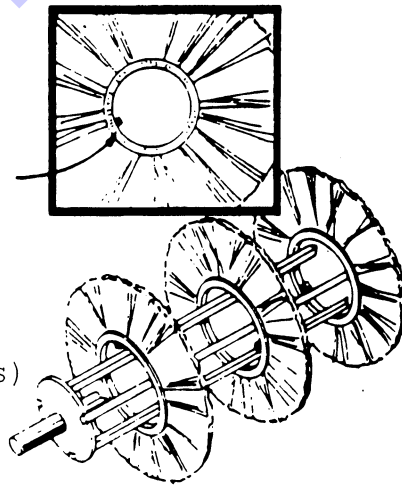

5. **MOUNTING CRIMPED WIRE WAFERS** - Each set of these wafers contain two polypropylene wafers which are to be placed on the ends. They keep the crimped wire from being entangled in cover braces and ect.
6. When last wafer-and-spacer-section is placed onto core reinstall flange if last section is 1/2 to 1-inch short of filling core (even after end flange is bolted down). Sections later locate themselves, filling entire core length.

CALIFORNIA

Proposition 65 Warning

Diesel engine exhaust and some of its constituents are known to the State of California to cause cancer, birth defects, and other reproductive harm.

WARNING: Battery posts, terminal and related accessories contain lead and lead compounds, chemicals known to the State of California to cause cancer and birth defects or other reproductive harm. **Wash hands after handling.**