

EXPLANATION OF CODE IN REMARKS COLUMN

The following section explains the different symbols and remarks used in the Parts section of this manual. Use the help numbers found on the back page of the manual if there are any questions.

NOTICE

The contents and part numbers listed in the parts section are subject to change **without notice**. Multiquip does not guarantee the availability of the parts listed.

SAMPLE PARTS LIST

NO.	PART NO.	PART NAME	QTY.	REMARKS
1	12345	BOLT.....	1	INCLUDES ITEMS W/%
2%		WASHER, 1/4 IN.....		NOT SOLD SEPARATELY
2%	12347	WASHER, 3/8 IN....	1	MQ-45T ONLY
3	12348	HOSE	A/R	MAKE LOCALLY
4	12349	BEARING	1	S/N 2345B AND ABOVE

NO. Column

Unique Symbols — All items with same unique symbol

(@, #, +, %, or >) in the number column belong to the same assembly or kit, which is indicated by a note in the “Remarks” column.

Duplicate Item Numbers — Duplicate numbers indicate multiple part numbers, which are in effect for the same general item, such as different size saw blade guards in use or a part that has been updated on newer versions of the same machine.

NOTICE

When ordering a part that has more than one item number listed, check the remarks column for help in determining the proper part to order.

PART NO. Column

Numbers Used — Part numbers can be indicated by a number, a blank entry, or TBD.

TBD (To Be Determined) is generally used to show a part that has not been assigned a formal part number at the time of publication.

A blank entry generally indicates that the item is not sold separately or is not sold by Multiquip. Other entries will be clarified in the “Remarks” Column.

QTY. Column

Numbers Used — Item quantity can be indicated by a number, a blank entry, or A/R.

A/R (As Required) is generally used for hoses or other parts that are sold in bulk and cut to length.

A blank entry generally indicates that the item is not sold separately. Other entries will be clarified in the “Remarks” Column.

REMARKS Column

Some of the most common notes found in the “Remarks” Column are listed below. Other additional notes needed to describe the item can also be shown.

Assembly/Kit — All items on the parts list with the same unique symbol will be included when this item is purchased.

Indicated by:

“INCLUDES ITEMS W/(unique symbol)”

Serial Number Break — Used to list an effective serial number range where a particular part is used.

Indicated by:

“S/N XXXXX AND BELOW”

“S/N XXXX AND ABOVE”

“S/N XXXX TO S/N XXX”

Specific Model Number Use — Indicates that the part is used only with the specific model number or model number variant listed. It can also be used to show a part is NOT used on a specific model or model number variant.

Indicated by:

“XXXXX ONLY”

“NOT USED ON XXXX”

“Make/Obtain Locally” — Indicates that the part can be purchased at any hardware shop or made out of available items. Examples include battery cables, shims, and certain washers and nuts.

“Not Sold Separately” — Indicates that an item cannot be purchased as a separate item and is either part of an assembly/kit that can be purchased, or is not available for sale through Multiquip.

SUGGESTED SPARE PARTS

EM12 SERIES MECHANICAL MIXER

1 to 3 units

Qty.	P/N	Description
6	491010	LATCH KIT, CABINET
1	EM200293B	PADDLE ARM, TOW END
1	EM200294B	PADDLE ARM CTR.TOW END
1	EM200295B	PADDLE ARM CTR.ENG END
1	EM200296B	PADDLE ARM, ENGINE END
4	EM200297	U-BOLT
3	EM200863	BLADE KIT, RUBBER
36	EM200301	PACKING RING
3	EM963157	CONNECTING BOLT
3	.9503	NUT, NYLOC
2	.29173-001	SWITCH, STOP

NOTICE

Part numbers on this Suggested Spare Parts list may supersede/replace the part numbers shown in the following parts lists.

HONDA GX390U1QA2 GASOLINE ENGINE

1 to 3 units

3	9807955846	SPARK PLUG
1	17620Z0T305	TANK CAP, CHROME PLATED
3	17210ZE3010	AIR CLEANER ELEMENT
2	17218ZE3000	FILTER OUTER
1	28462ZE3W01	ROPE, RECOIL

NAMEPLATE AND DECALS ASSY.

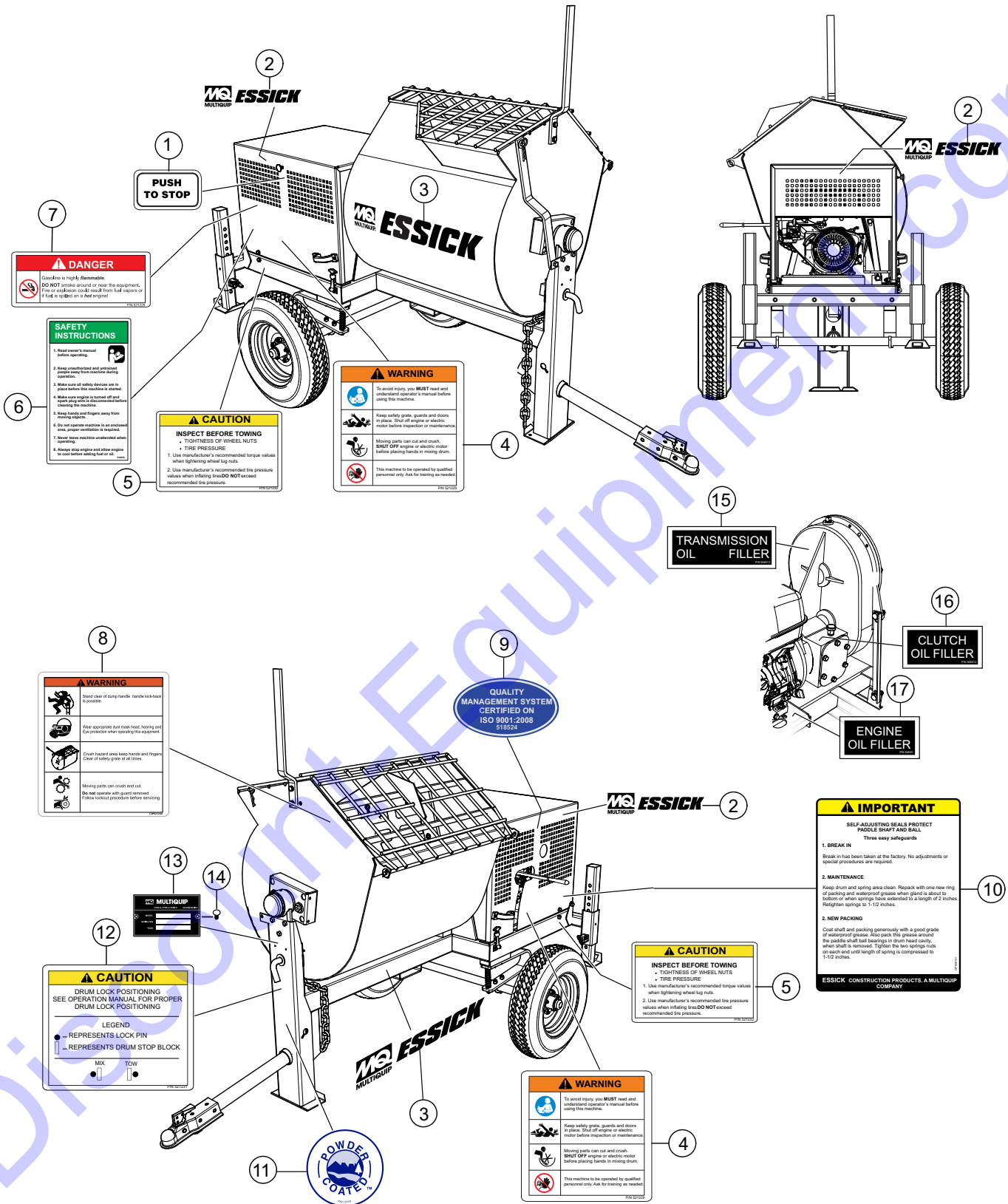

DANGER
Gasoline is highly flammable.
DO NOT smoke around or near the equipment.
Fire or explosion could result from fuel vapors or if fuel is spilled on a hot engine!

SAFETY INSTRUCTIONS

- Read owner's manual before operating.
- Keep unobstructed and unobeyed surroundings from machine during operation.
- Make sure all safety devices are in place before the machine starts.
- Make sure engine is turned off and cool before any maintenance or repair.
- When using and/or repairing any electrical equipment, proper ventilation is required.
- Make sure machine is properly grounded when operating.
- Always wear eye protection when working with tools or equipment.

CAUTION
INSPECT BEFORE TOWING
• TIGHTNESS OF WHEEL NUTS
• TIRE PRESSURE

- Use manufacturer's recommended torque values when tightening wheel lug nuts.
- Use manufacturer's recommended tire pressure values when inflating tires. DO NOT exceed recommended tire pressure.

WARNING

To avoid injury, you MUST read and understand operator's manual before using this machine.

Keep safety guards, guards and doors in place. Shut off engine or electric motor before inspection or maintenance.

Moving parts can cut and crush. SHUT OFF engine or electric motor before placing hands in moving drum.

This machine is to be operated by qualified personnel only. Ask for training as needed.

TRANSMISSION OIL FILLER

CLUTCH OIL FILLER

ENGINE OIL FILLER

WARNING

- Keep clear of dump handle handle lock when in position.
- Wear appropriate foot wear (boots, hiking and cleats) when operating the equipment.
- Death hazard areas keep hands and fingers clear of safety grade at all times.
- Moving parts can crush and cut. Do not operate with guard removed. Follow correct procedure before working.

QUALITY MANAGEMENT SYSTEM CERTIFIED ON ISO 9001:2008 518524

IMPORTANT
SELF-ADJUSTING SEALS PROTECT PADDLE SHAFT AND BALL
Three easy safeguards:

- BREAK IN**
Break in has been taken at the factory. No adjustments or special procedures are required.
- MAINTENANCE**
Keep drum and spring area clean. Repack with one new ring of packing and waterproof grease when grease is above to bottom of which springs have extended to a length of 2 inches. Retighten springs to 1-1/2 inches.
- NEW PACKING**
Coat shaft and packing generously with a good grade of waterproof grease. Also pack this grease around the paddle shaft ball bearings in drum head cavity, when shell is removed. Tighten the two springs nuts on each end until length of spring is compressed to 1-1/2 inches.

ESSICK CONSTRUCTION PRODUCTS A MULTIGRIP COMPANY

CAUTION
DRUM LOCK POSITIONING
SEE OPERATION MANUAL FOR PROPER DRUM LOCK POSITIONING

LEGEND
● REPRESENTS LOCK PIN
■ REPRESENTS DRUM STOP BLOCK

MIX TOW

CAUTION
INSPECT BEFORE TOWING
• TIGHTNESS OF WHEEL NUTS
• TIRE PRESSURE

- Use manufacturer's recommended torque value when tightening wheel lug nuts.
- Use manufacturer's recommended tire pressure values when inflating tires. DO NOT exceed recommended tire pressure.

WARNING

To avoid injury, you MUST read and understand operator's manual before using this machine.

Keep safety guards, guards and doors in place. Shut off engine or electric motor before inspection or maintenance.

Moving parts can cut and crush. SHUT OFF engine or electric motor before placing hands in moving drum.

This machine is to be operated by qualified personnel only. Ask for training as needed.

NAMEPLATE AND DECALS ASSY.

<u>NO.</u>	<u>PART NO.</u>	<u>PART NAME</u>	<u>QTY.</u>	<u>REMARKS</u>
1	948630	DECAL; PUSH TO STOP	1	
2	510891	DECAL; MQ ESSICK (SMALL)	3	
3	510883	DECAL; MQ ESSICK (LARGE)	2	
4	521229	DECAL; WARNING, BODILY INJURY	2	
5	521232	DECAL; CAUTION INSPECT BEFORE TOW	2	
6	520935	DECAL; SAFETY INSTRUCTIONS	1	
7	521228	DECAL; DANGER, NO SMOKING	2	
8	521230	DECAL; WARNING, PREVENT ACCIDENTS	1	
9	518524	DECAL; ISO 9001:2000 EXPORT	1	
10	948121	DECAL; IMPORTANT, SELF-ADJUSTING SEAL	1	
11	13118	DECAL; POWDER COATED	1	
12	521231	DECAL; DRUM LOCK POSITION	1	
13		NAMEPLATE.....	1	CONTACT MQ PARTS DEPT.
14	503723	RIVET; ID PLATE	2	
15	948013	DECAL; TRANSMISSION OIL FILLER	1	
16	948012	DECAL; CLUTCH OIL FILLER	1	
17	948005	DECAL; ENGINE OIL FILLER	1	

PADDLE BLADES ASSY.

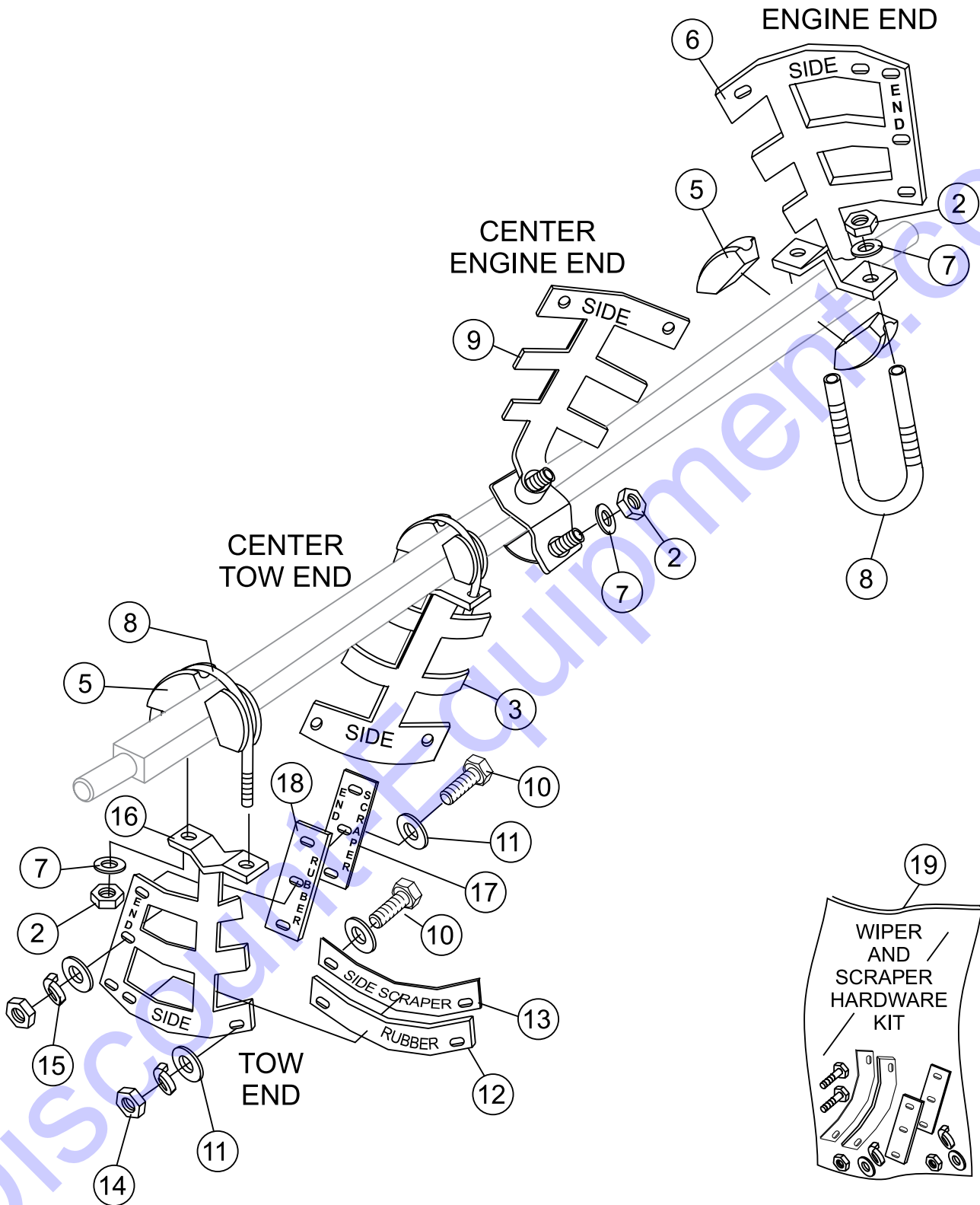

PADDLE BLADES ASSY.

<u>NO.</u>	<u>PART NO.</u>	<u>PART NAME</u>	<u>QTY.</u>	<u>REMARKS</u>
2	492584	NUT, LOCK 1/2" DIA. NC	8	
3	EM200294B	PADDLE ARM, CENTER (TOW END)	1	
5	EM200292	INSERT, PADDLE ARM	8.....	REPLACES P/N 200292
6	EM200296B	PADDLE ARM, ENGINE END	1	
7	6109170	WASHER, FLAT 1/2"	8.....	REPLACES P/N 504322
8	EM200297	U-BOLT	4.....	REPLACES P/N 200297
9	EM200295B	PADDLE ARM, CENTER (ENGINE END)	1	
10\$	2105162	SCREW HHC.....	14.....	REPLACES P/N 492367
11\$	EM923023	WASHER, FLAT 3/8"	28.....	REPLACES P/N 492597
12\$	EM200212	SIDE WIPER, RUBBER	4	
13\$	EM203432	SIDE SCRAPER BLADE	4	
14\$	2105164	NUT HEX 5/16" DIA. NC.....	14.....	REPLACES P/N 492553
15\$	EM923343	WASHER, LOCK 5/16"	14.....	REPLACES P/N 492623
16	EM200293B	PADDLE ARM, TOW END	1	
17	EM203433	END SCRAPER BLADE	2	
18	EM200213	END WIPER, RUBBER	2	
19	EM200863	KIT, RUB. BLADES, SCRAPERS AND HDW.	1.....	INCLUDES ITEMS W/\$

DRUM AND SHAFT ASSY.

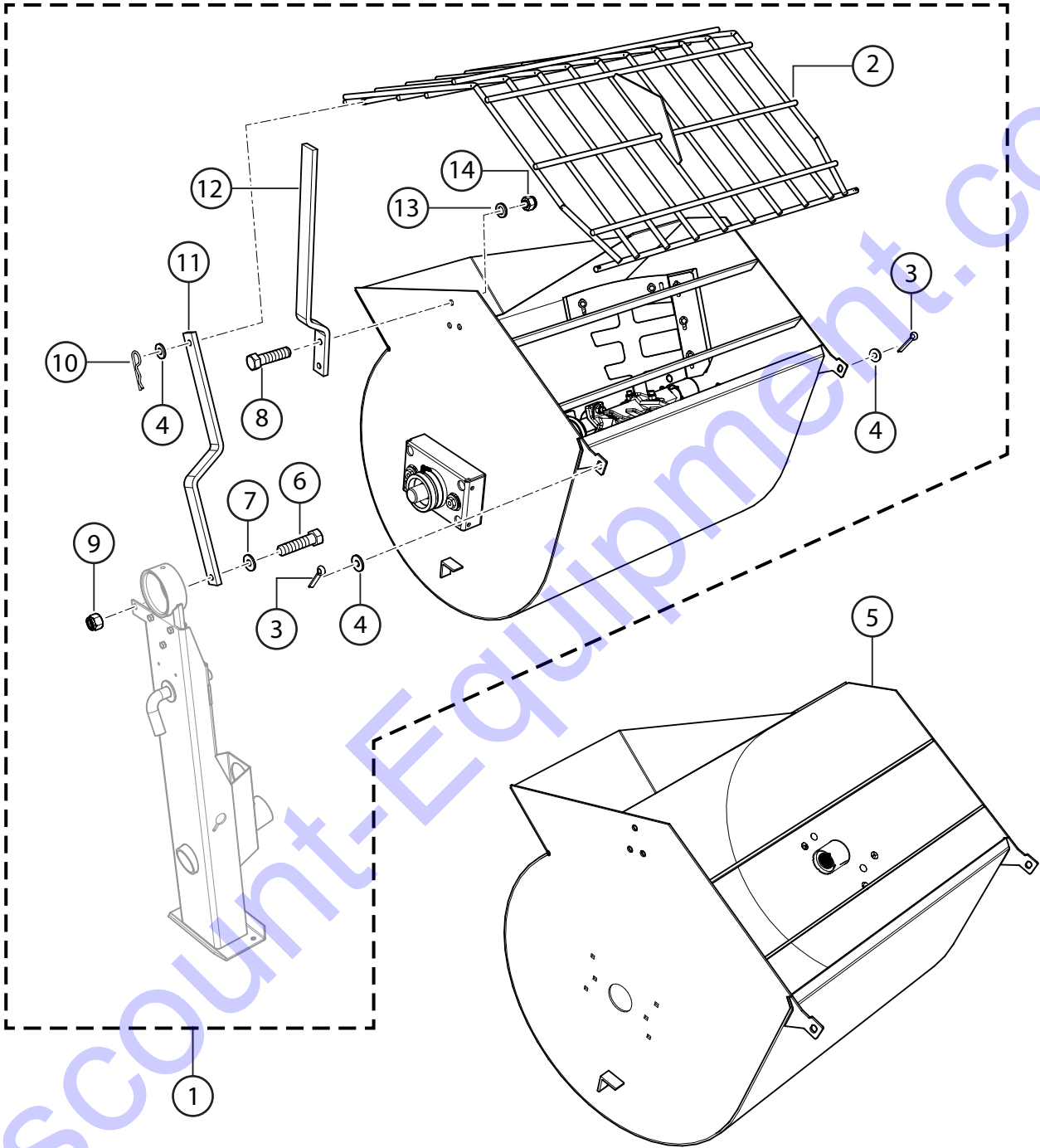

DRUM AND SHAFT ASSY.

<u>NO.</u>	<u>PART NO.</u>	<u>PART NAME</u>	<u>QTY.</u>	<u>REMARKS</u>
1	805919	DRUM AND SHAFT ASSY.....	1.....	INCLUDES ITEMS W/#
2#	EM203449	DRUM GRILL	1	
3#	EM924015	PIN, COTTER	2.....	REPLACES P/N 505070
4#	6109170	WASHER, FLAT 1/2" DIA.....	3.....	REPLACES P/N 492600
5	804915	DRUM 12 CU. FT.....	1.....	DRUM ONLY
6#	EM963692	BOLT, 1/2" UNC X 1-1/2"	1.....	REPLACES P/N 492394
7#	6109170	WASHER, FLAT 1/2" DIA.....	1.....	REPLACES P/N 492600
8#	EM963692	BOLT, 1/2" UNC X 1-1/2"	2.....	REPLACES P/N 492394
9#	492584	NUT, NYLOC 1/2" DIA.	1	
10#	EM925191	PIN, HAIR 3/16" WIRE SIZE	1	
11#	EM203344	BAR, GRILL OPENING	1	
12#	EM201537	DUMP LEVER.....	1.....	REPLACES P/N 201537
13#	6109180	WASHER, LOCK 1/2" DIA	2.....	REPLACES P/N 492626
14#	6109160	NUT HEX 1/2" DIA-NC	2.....	REPLACES P/N 492556

PADDLE SHAFT ASSY.

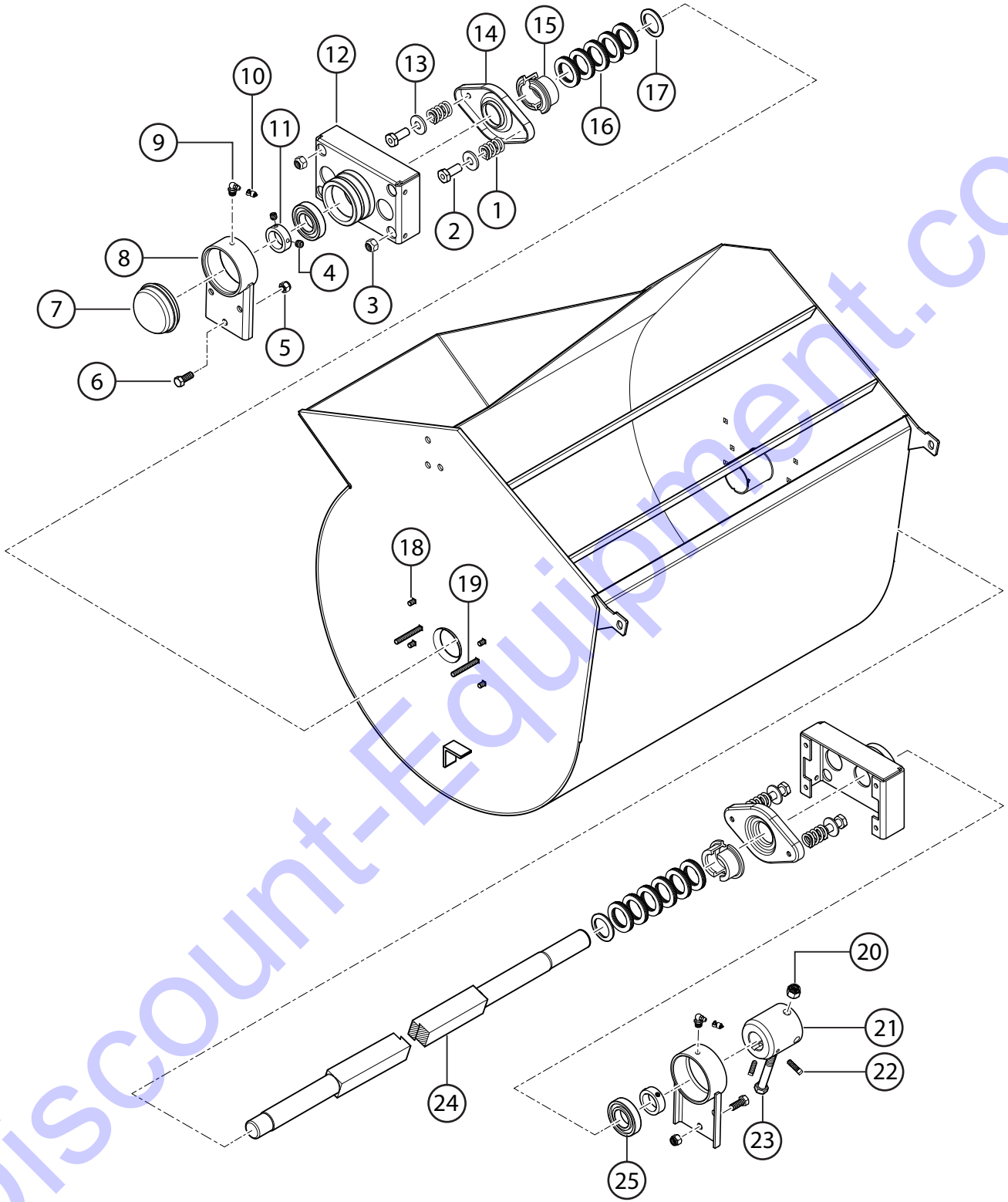

PADDLE SHAFT ASSY.

<u>NO.</u>	<u>PART NO.</u>	<u>PART NAME</u>	<u>QTY.</u>	<u>REMARKS</u>
1	507844	SPRING	4	
2	EM200287	ADJUSTING NUT	4	
3	EM969012	NUT, NYLOC 3/8"	8.....	REPLACES P/N 505066
4	EM703	SCREW, ALLEN 3/8"	4.....	REPLACES P/N 492470
5	492584	NUT LOCK 1/2" DIA NC	6	
6	EM963102	BOLT, G5.....	6.....	REPLACES P/N 492393
7	3249	CAP, DUST	1	
8	804887	BEARING BRACKET	2	
9	EM916006	GREASE ZERK	2.....	REPLACES P/N 491703
10	491008	GREASE CAP FITTING	2	
11	EM200018	COLLAR, PADDLE SHAFT	2	
12	EM201648	DRUM HEAD WELDMENT	2	
13	0401450160	WASHER, FLAT 5/8".....	4.....	REPLACES P/N 492602
14	EM200288	PLATE, PACKING GLAND PRESSURE	2	
15	EM200285	GLAND, PACKING HALF	4	
16	EM200301	RING, SHAFT PACKING	12	
17	EM200303	FOLLOWER, PACKING RING	2	
18	17985-008	BOLT, CARRIAGE.....	8.....	REPLACES P/N 505064
19	EM200286	BOLT, CARRIAGE.....	4.....	REPLACES P/N 505065
20	EM969023	NUT LOCK 5/8"	1.....	REPLACES P/N 492586
21	EM200255	COUPLER, PADDLE SHAFT	1	
22	EM961019	SCREW SET.....	2.....	REPLACES P/N 492484
23	EM963157	BOLT HD 5/8 NC X 4-1/2" G5	1	
24	EM200333	PADDLE SHAFT	1	
25	EM902153	BEARING BALL	2	

FRAME ASSY.

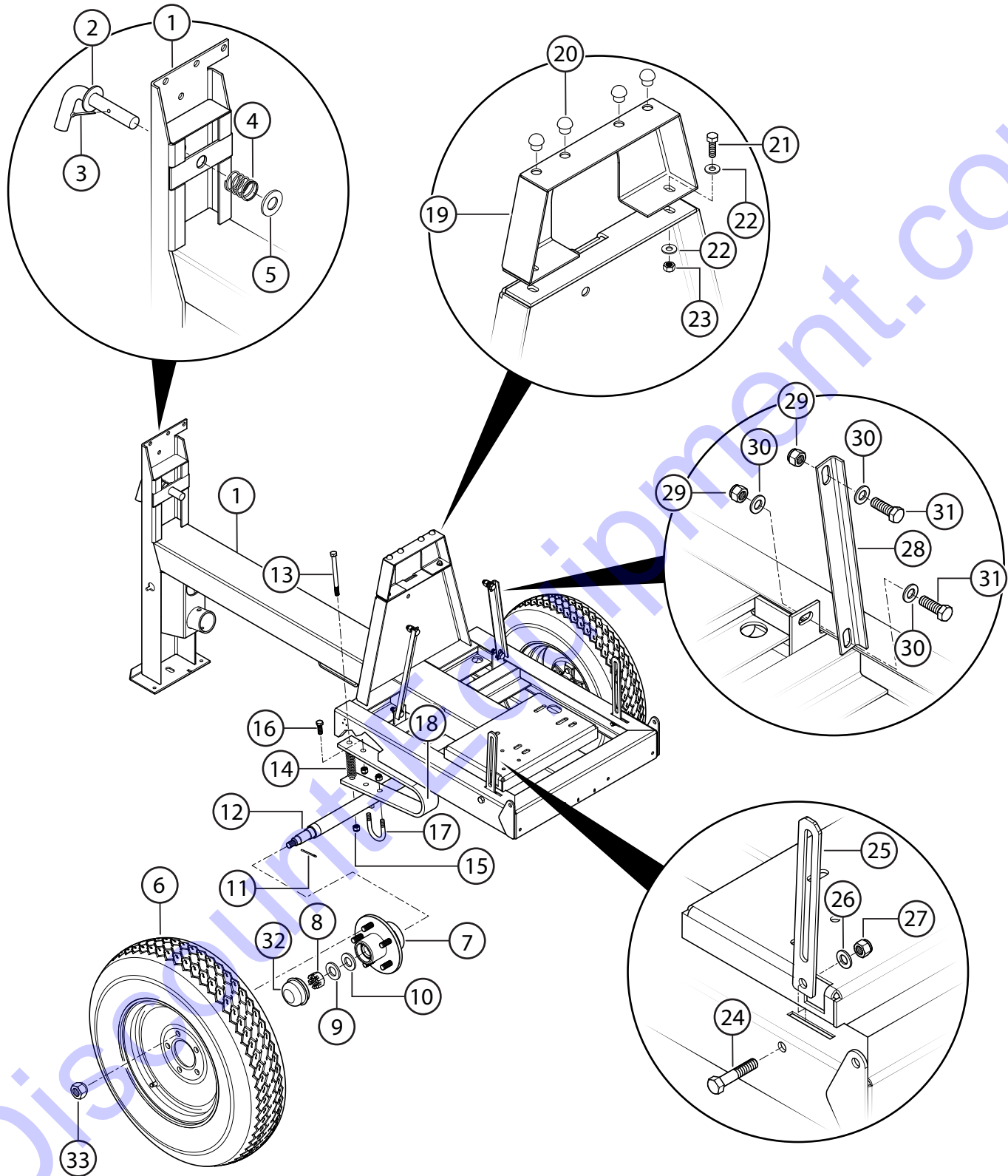

FRAME ASSY.

<u>NO.</u>	<u>PART NO.</u>	<u>PART NAME</u>	<u>QTY.</u>	<u>REMARKS</u>
1	804917	CHASSIS ASSY.	1	
2	804903	HANDLE, DRUM LOCK	1	
3	509000	PIN, COTTER	1	
4	EM14810	SPRING JOLTER	1	
5	501269	SPACER	1	
6	516477	WHEEL/TIRE ASSY.	2	
7	EM941277	HUB COMPLETE, 5 LUGS	2	
8	492534	NUT, CASTLE 3/4"	2	
9	507444	WASHER, FLAT 3/4"	2	
10	504708	WASHER, FLAT 3/4"	2	
11	EM924008	PIN, COTTER 1/8" X 1-1/2"	2	REPLACES P/N 491688
12	804907	WHEEL SHAFT	1	
13	3043	BOLT 1/2" X 6" G5	2	REPLACES P/N 510721
14	3076	SPRING, AXLE	2	
15	492584	NUT LOCK 1/2" DIA.	10	
16	EM963692	BOLT 1/2" UNC X 1-1/2"	4	REPLACES P/N 492394
17	3028	U-BOLT, AXLE	2	
18	3018	SPRING, LEAF	2	
19	804905	COVER, ENGINE SUPPORT	1	
20	TK6597572	BUMPER	4	
21	0202	SCREW HHC 5/16X18X1	2	REPLACES P/N 492364
22	EM923057	WASHER 1/4"	4	REPLACES P/N492596
23	492541	NUT 5/16 HEX G2	2	
24	492397	SCREW HEX 1/2" NC X 2-1/2" G5	2	
25	805001	SLIDE, ENGINE COVER	2	
26	EM923023	WASHER 5/16"	2	REPLACES P/N 505679
27	EM969013	NUT NYLOC 3/8" G8	2	REPLACES P/N 492583
28	805773	TRANSMISSION SUPPORT	1	
29	492584	NUT LOCK 1/2" DIA.	4	
30	6109170	WASHER FLAT 1/2"	6	REPLACES P/N 504322
31	EM963692	BOLT 1/2" UNC X 1-1/2"	4	REPLACES P/N 492394
32	EM941278	CAP, HUB	2	
33	EM941280	WHEEL NUT	10	

TOW BAR ASSY.

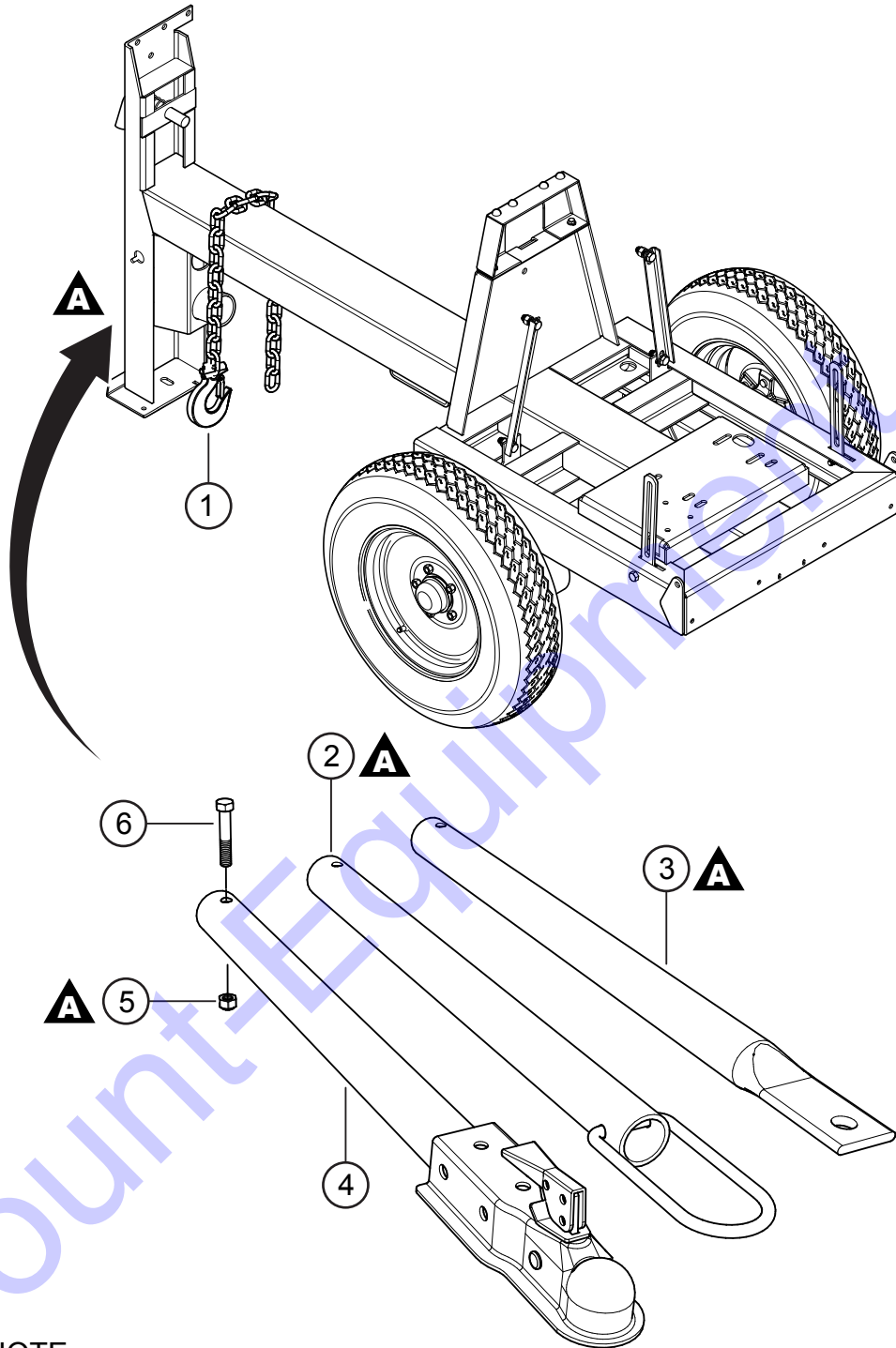

A NOTE:
OPTIONAL TOW BARS

TOW BAR ASSY.

<u>NO.</u>	<u>PART NO.</u>	<u>PART NAME</u>	<u>QTY.</u>	<u>REMARKS</u>
1	516580	CLEVIS SAFETY HOOK, 1/4"	1	
2	HLC-1	TOW BAR (LOOP)	1	CONTACT SALES
3	HPC-1	TOW BAR (1" PIN)	1	CONTACT SALES
4	HBC-1	TOW BAR (BALL HITCH 2-IN)	1	CONTACT SALES
5	10176	NUT	1	
6	EM124	BOLT	1	

CABINET ASSY.

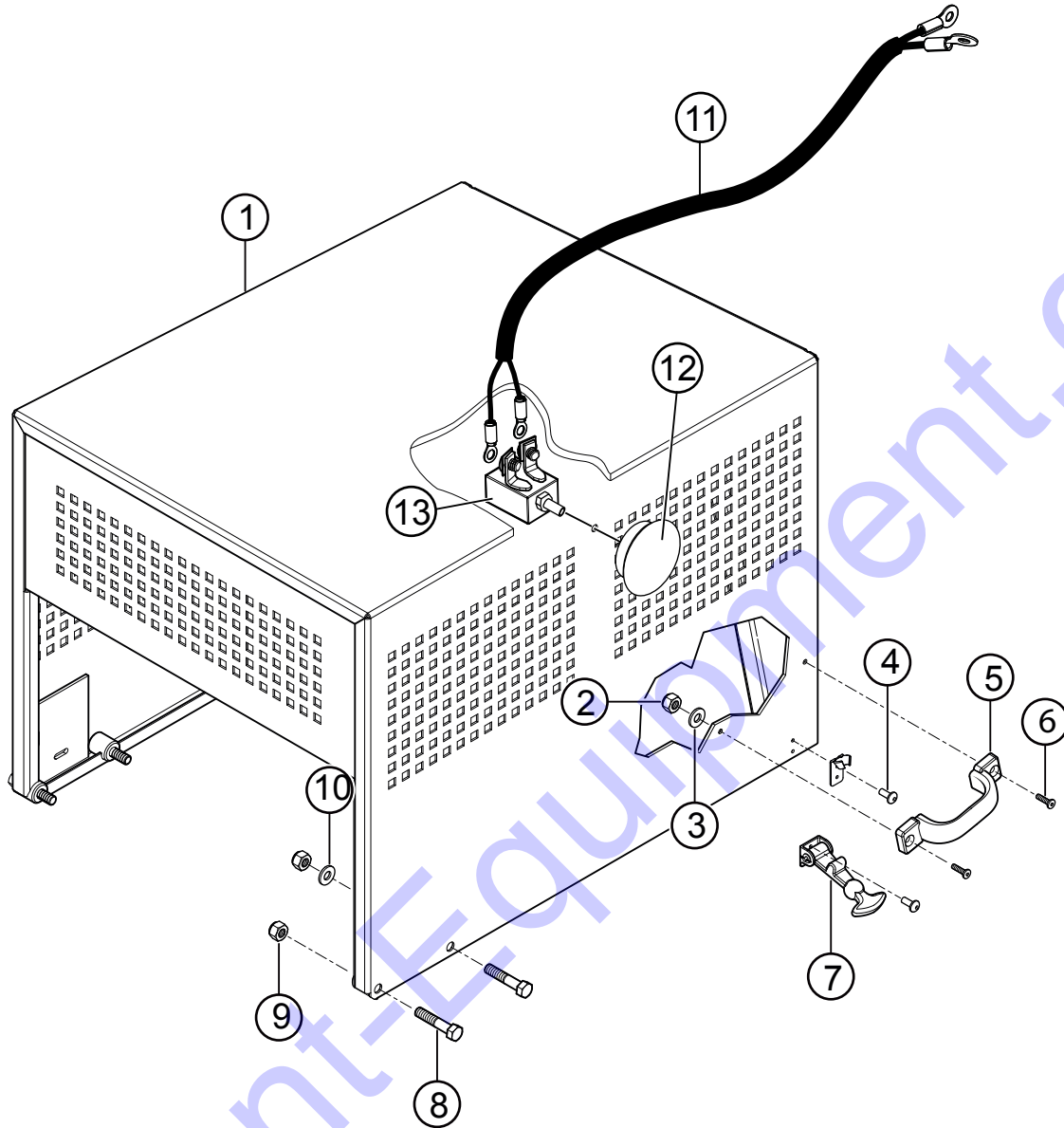

CABINET ASSY.

<u>NO.</u>	<u>PART NO.</u>	<u>PART NAME</u>	<u>QTY.</u>	<u>REMARKS</u>
1	804913	ENGINE, COVER	1	
2	492581	NUT, 1/4"-20 NYLON LOCKNUT	4	
3	492595	WASHER, FLAT 3/16	4	
4	512881	RIVET	12	REPLACES P/N 503723
5	802751	HANDLE, COVER	2	
6	513312	BOLT, 1/4" X 1"	4	
7	491010	RUBBER LATCH KIT ENGINE HOUSING	2	
8	492397	SCREW, HEX 1/2" NC X 2-1/2" G5	4	
9	492584	NUT, LOCK 1/2"	4	
10	6109170	WASHER, FLAT 1/2"	2	REPLACES P/N 504322
11	510573	ENGINE, CABLE HARNESS	1	
12	29174-001	BUTTON, STOP	1	
13	29173-001	SWITCH, STOP	1	

Discount-Equipment.com

ENGINE ASSY.

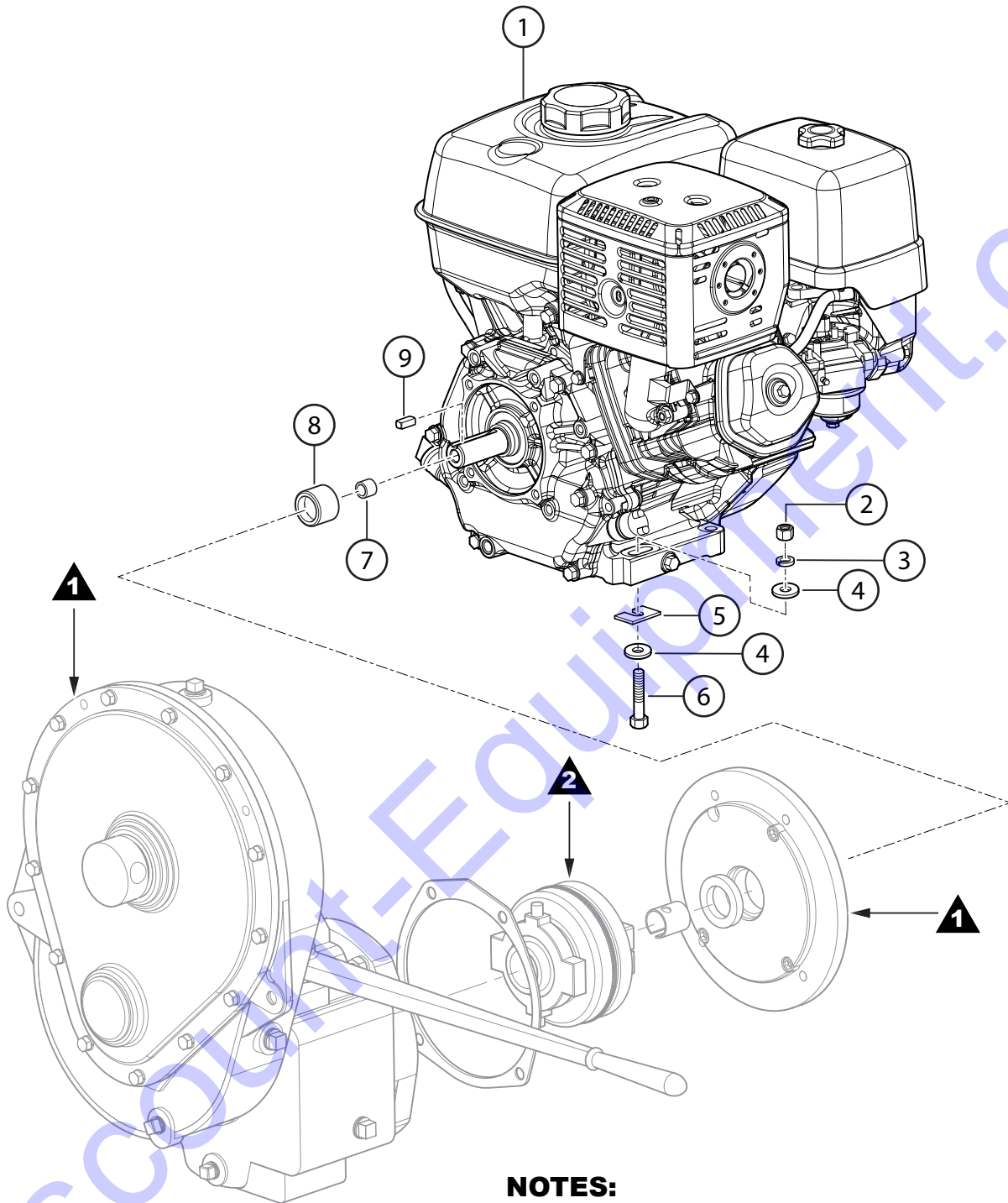

NOTES:

- ▲1** REFER TO "TRANS. ASSY." FOR PART NO.
- ▲2** REFER TO "CLUTCH ASSY." FOR PART NO.

ENGINE ASSY.

<u>NO.</u>	<u>PART NO.</u>	<u>PART NAME</u>	<u>QTY.</u>	<u>REMARKS</u>
1	521691	ENGINE, HONDA GX390U1QA2 MODIFIED	1	
2	1456	NUT, HEX 3/8"	4	REPLACES P/N 492554
3	0166A	WASHER, LOCK 3/8" DIA.	4	REPLACES P/N 492624
4	3019092	WASHER, FLAT 3/8"	8	
5	511122	FITTING, ENGINE	2	
6	492379	SCREW CAP 3/8"	4	
7	801570	BRONZE PILOT BUSHING	1	
8	13376	SLEEVE	1	
9	EM927066	KEY, 1/4" X 5/16" X 1"	1	

1Ø 230 VAC, 60 HZ. ELECTRIC MOTOR ASSY.

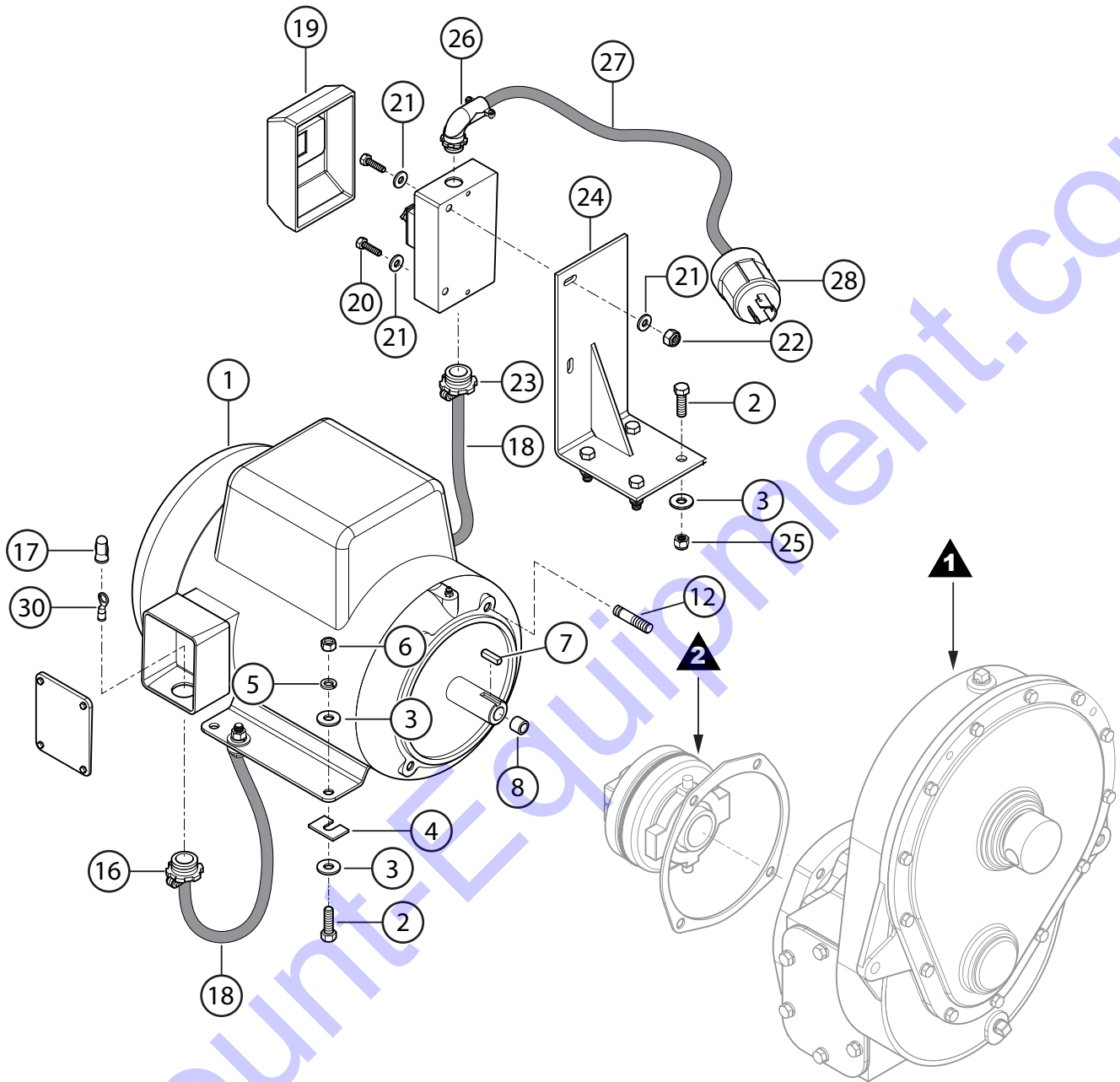

NOTES:

▲1 REFER TO "TRANSMISSION ASSY." FOR PART NO.

▲2 REFER TO "CLUTCH ASSY." FOR PART NO.

1Ø 230 VAC, 60 HZ. ELECTRIC MOTOR ASSY.

<u>NO.</u>	<u>PART NO.</u>	<u>PART NAME</u>	<u>QTY.</u>	<u>REMARKS</u>
1	EM939228	MOTOR, ELECTRIC 5HP, 1PH	1	
2	EM963610	BOLT 3/8" NC X 1-1/4" G5.....	8.....	REPLACES P/N 492376
3	3019092	WASHER, FLAT 3/8".....	12.....	REPLACES P/N 492598
4	511122	FITTING, ENGINE	6	
5	0166A	WASHER, LOCK 3/8".....	4.....	REPLACES P/N 492624
6	1456	NUT HEX 3/8" G5.....	4.....	REPLACES P/N 492554
7	EM502625	KEY 1/4" X 25MM	1	
8	EM801570	BUSHING, PILOT	1	
12	512223	STUD 7/16" X 2	4	
16	508135	CONNECTOR	1	
17	505502	CONNECTOR COVER	3	
18	508683	CABLE, 3-WIRE	2	
19	EM98187	SWITCH ASSY. 5HP 1PH	1	
20	EM492357	BOLT 1/4" X 1"	3	
21	EM923057	WASHER 1/4".....	6.....	REPLACES P/N 492596
22	492581	NYLON LOCKNUT 1/4"-20	3	
23	517031	CONNECTOR	1	
24	805783	MOUNT BRACKET	1	
25	EM969013	NUT NYLOC.....	4.....	REPLACES P/N 492583
26	EM940162	CONDUIT CONNECTOR 90° ELBOW	1	
27	508683	CABLE 3-WIRE, HEAVY DUTY	1	
28	940547	PLUG, L6-30P, 3-PRONG	1	
30	505403	TERMINAL	1	

3Ø 230/460 VAC, 60 HZ. ELECTRIC MOTOR ASSY.

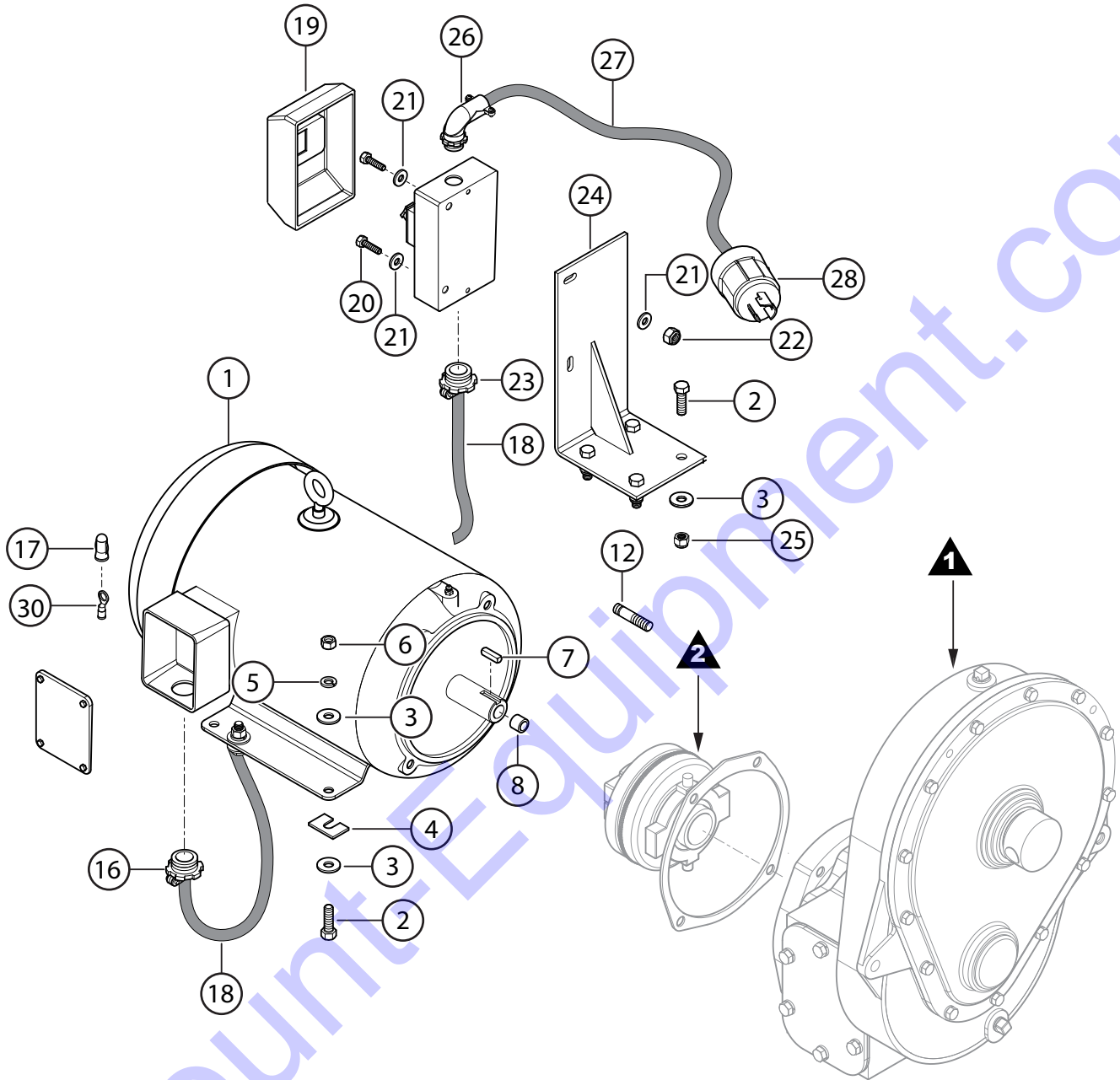

NOTES:

▲ **1** REFER TO "TRANSMISSION ASSY." FOR PART NO.

▲ **2** REFER TO "CLUTCH ASSY." FOR PART NO.

3Ø 230/460 VAC, 60 HZ. ELECTRIC MOTOR ASSY.

<u>NO.</u>	<u>PART NO.</u>	<u>PART NAME</u>	<u>QTY.</u>	<u>REMARKS</u>
1	EM939229	MOTOR, ELEC. 5HP, 3PH	1	
2	EM963610	BOLT 3/8".....	8.....	REPLACES P/N 492376
3	3019092	WASHER, FLAT 3/8".....	12.....	REPLACES P/N 492598
4	511122	FITTING, ENGINE	6	
5	0166A	WASHER LOCK 3/8" DIA.	4.....	REPLACES P/N 492624
6	1456	NUT, HEX 3/8".....	4.....	REPLACES P/N 492554
7	EM502625	KEY 1/4" X 25MM	1	
8	EM801570	BUSHING, PILOT	1	
12	512223	STUD 7/16" X 2	4	
16	508135	CONNECTOR	1	
17	505502	CONNECTOR COVER	4	
18	521701	CABLE 4- WIRE, HEAVY DUTY	2	
19	EM98191	SWITCH ASSY. 5HP, 3PH	1	
20	EM492357	BOLT 1/4" X 1"	3	
21	EM923057	WASHER 1/4".....	6.....	REPLACES P/N 492596
22	492581	NYLON LOCKNUT 1/4"-20	3	
23	517031	CONNECTOR	1	
24	805783	MOUNT BRACKET	1	
25	EM969013	NUT NYLOC.....	4.....	REPLACES P/N 492583
26	EM940162	CONDUIT CONNECTOR 90° ELBOW	1	
27	521701	CABLE 4-WIRE, HEAVY DUTY	1	
28	511647	PLUG, L14-30P, 4-PRONG	1	
30	505403	TERMINAL	1	

CLUTCH ASSY.

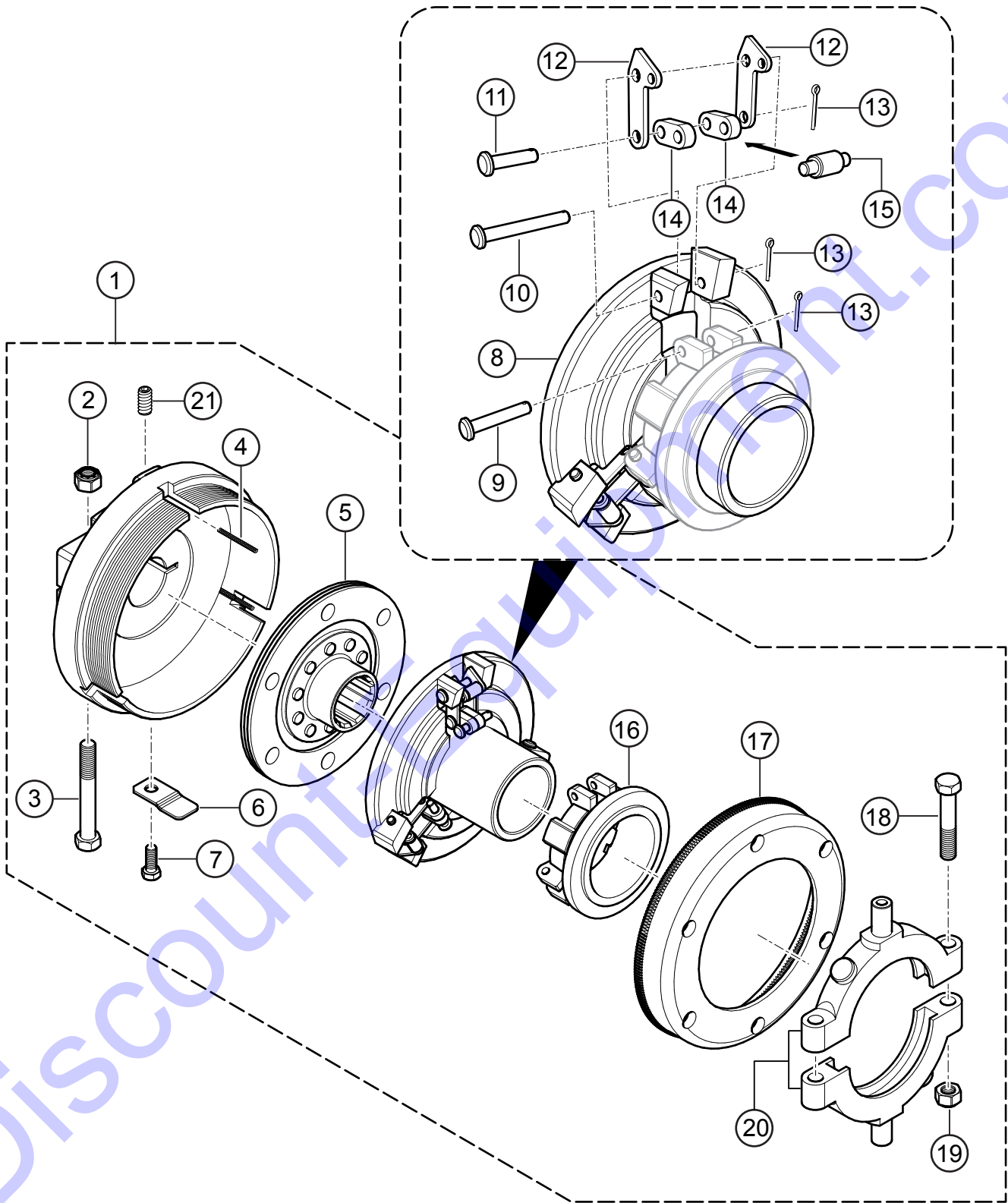

CLUTCH ASSY.

<u>NO.</u>	<u>PART NO.</u>	<u>PART NAME</u>	<u>QTY.</u>	<u>REMARKS</u>
1	EM934022	CLUTCH ASSEMBLY	1	INCLUDES ITEMS W/\$
2\$	2656	NUT, NYLOC 5/16-24	1	
3\$	EM963289	BOLT, 5/16-24 X 1-3/4" HEX	1	
4\$	EM918009	SPRING, RELEASE	3	
5\$	EM934041	DRIVEN MEMBER	1	
6\$	EM934040	LOCK, ADJUSTING	1	
7\$	N/A	BOLT HHCS 1/4-20 X 1/2"	1	
8\$	EM934042	PRESSURE PLATE	1	
9\$	EM925013	PIN 3/16 X 1-3/8	3	
10\$	EM925016	PIN 3/15 X1	3	
11\$	EM925018	PIN 3/16 X 3/4	3	
12\$	EM959012	LEVER	6	
13\$	5117	COTTER PIN 1/16D X 1/2	9	
14\$	EM934053	CONNECTING LINK	6	
15\$	EM934054	ROLLER	3	
16\$	EM934032	RELEASE SLEEVE	1	
17\$	EM934045	ADJUSTING RING	1	
18\$	EM963289	BOLT 5/16-24 X 1-3/4 HEX	2	
19\$	2656	NUT, NYLOC 5/16-24	2	
20\$	EM934044	RELEASE BEARING ASSEMBLY	1	
21\$	EM961045	SET SCREW 5/16-18 1/2	1	

TRANSMISSION ASSY.

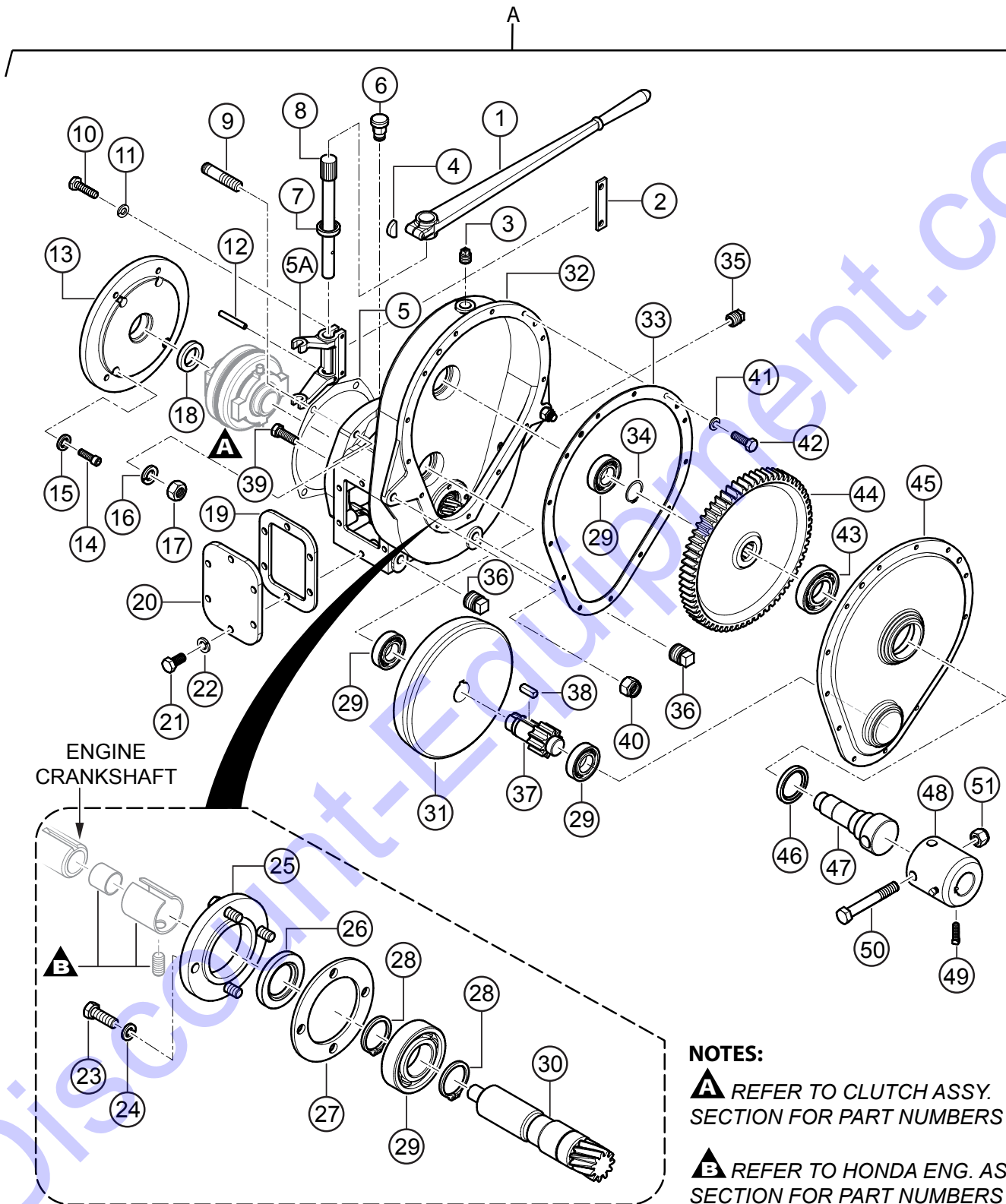

TRANSMISSION ASSY.

<u>NO.</u>	<u>PART NO.</u>	<u>PART NAME</u>	<u>QTY.</u>	<u>REMARKS</u>
A	EM600000	COMP. TRANSMISSION ASSY.....	1.....	INCLUDES ITEMS W/#
1#	EM600018	LEVER	1	
2#	EM600024	LOCK PLATE	1	
3#	EM922356	BREATHER	1	
4#	EM927048	KEY, WOODRUFF	1	
5#	EM801965	GASKET	1	
5A#	EM600028	CLUTCH YOKE	1	
6#	511233	BREATHER	1	
7#	EM914005	OIL SEAL	1	
8#	EM600029	SHIFTER SHAFT	1	
9#	EM300999	STUD	4	
10#	0730	HHCS 1/4-20X1	2	
11#	181B	LOCK, WASHER 1/4	2	
12#	1729	ROLL PIN	1	
13#	EM203038	ADAPTER PLATE KIT, HONDA	1	
14#	11090	SCREW, SHCS 3/8-16 X 1-1/4 PLTD	4	
15#	13379	WASHER, COPPER	4	
16#	2599	LOCK, WASHER 1/16-14	4	
17#	EM492555	HHCS 1/4-14	4	
18#	13377	OIL SEAL	1	
19#	EM600026	GASKET	1	
20#	EM931233	COVER PLATE	1	
21#	4196	HHCS 3/8-16 X 3/4	4	
22#	1875	LOCK, WASHER 3/8	4	
23#	0202	HHCS 5/16-18X1	4	
24#	0161C	LOCK, WASHER 5/16	4	
25#	EM600023	BEARING RETAINER	1	
26#	EM914209	OIL SEAL	1	
27#	EM600022	GASKET, RETAINER	1	
28#	EM926029	SNAP RING	2	
29#	EM902091	BALL BEARING	4	
30#	EM600016	INPUT SHAFT	1	

EM12M — TRANSMISSION ASSY. (CONT'D.)

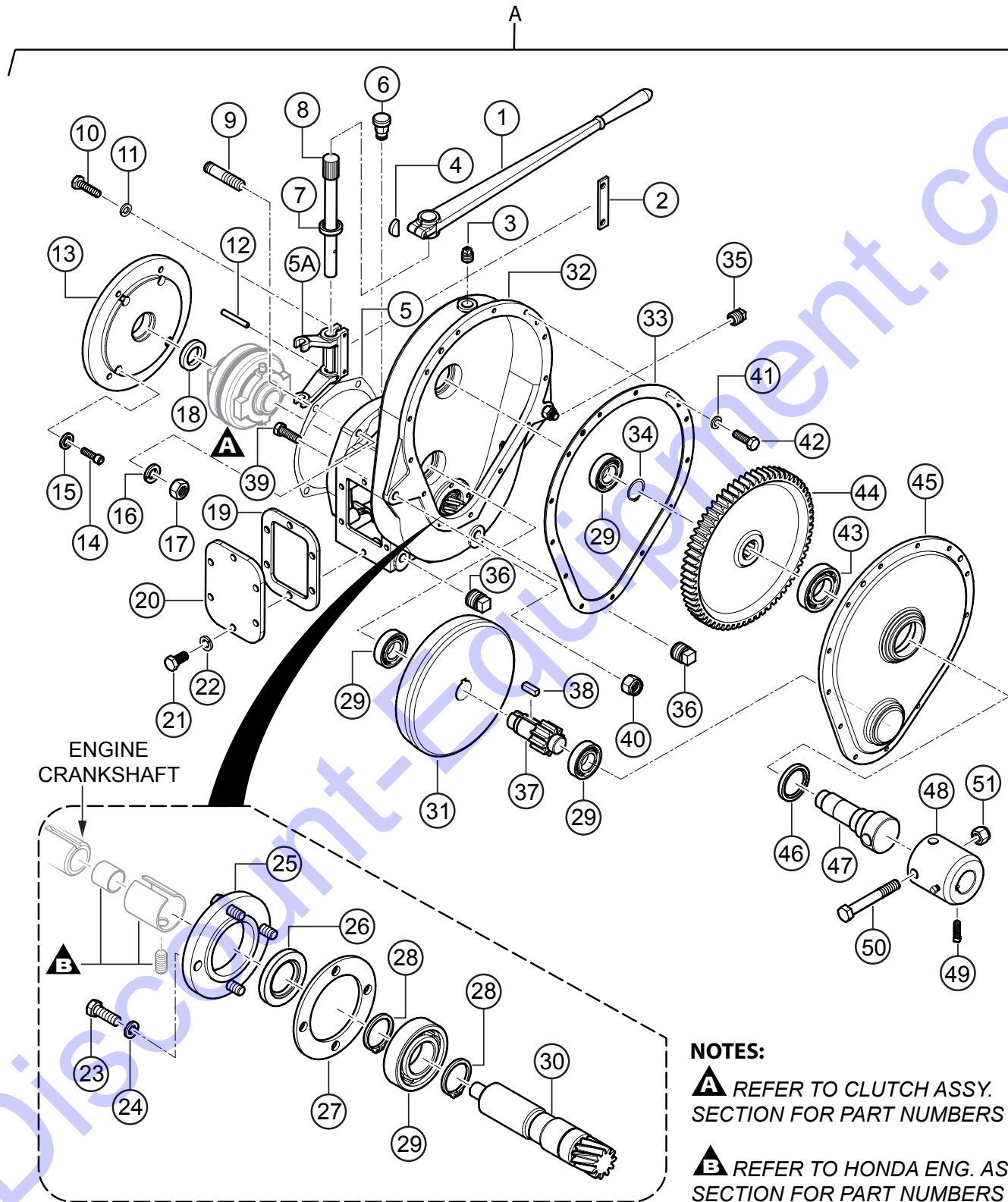

EM12M — TRANSMISSION ASSY. (CONT'D.)

<u>NO.</u>	<u>PART NO.</u>	<u>PART NAME</u>	<u>QTY.</u>	<u>REMARKS</u>
31#	EM600020	INTERNAL GEAR	1	
32#	EM600012	TRANSMISSION HOUSING	1	
33#	EM600021	GASKET	1	
34#	EM926036	SNAP RING	1	
35#	EM511064	SQUARE HEAD PLUG 1/2"	1	
36#	EM911329	SQUARE PIPE PLUG 3/8"	2	
37#	EM600131	OUTPUT DRIVE PINION	1	
38#	EM010062	SQUARE KEY 3/8" X 3/8"	1	
39#	5218	HHCS 1/2-13 X 1-1/2	1	
40#	10176	1/2-13 NYLOC NUT	1	
41#	0161C	LOCK, WASHER 5/16	17	
42#	EM0202	HHCS 5/16-18 X 1	17	
43#	EM902161	BALL BEARING	1	
44#	EM600133	OUTPUT SHAFT GEAR	1	
45#	EM600014	TRANSMISSION COVER	1	
46#	EM914207	OIL SEAL	1	
47#	EM600015	OUTPUT SHAFT	1	
48#	EM200255	CONNECTOR	1	
49#	EM961019	SQUARE HHS 3/8 X 1-1/4	2	
50#	EM963157	BOLT, 5/8 G5 ONLY	1	
51#	EM969085	NUT, NYLOC 5/8	1	

ENGINE SERVICE PARTS

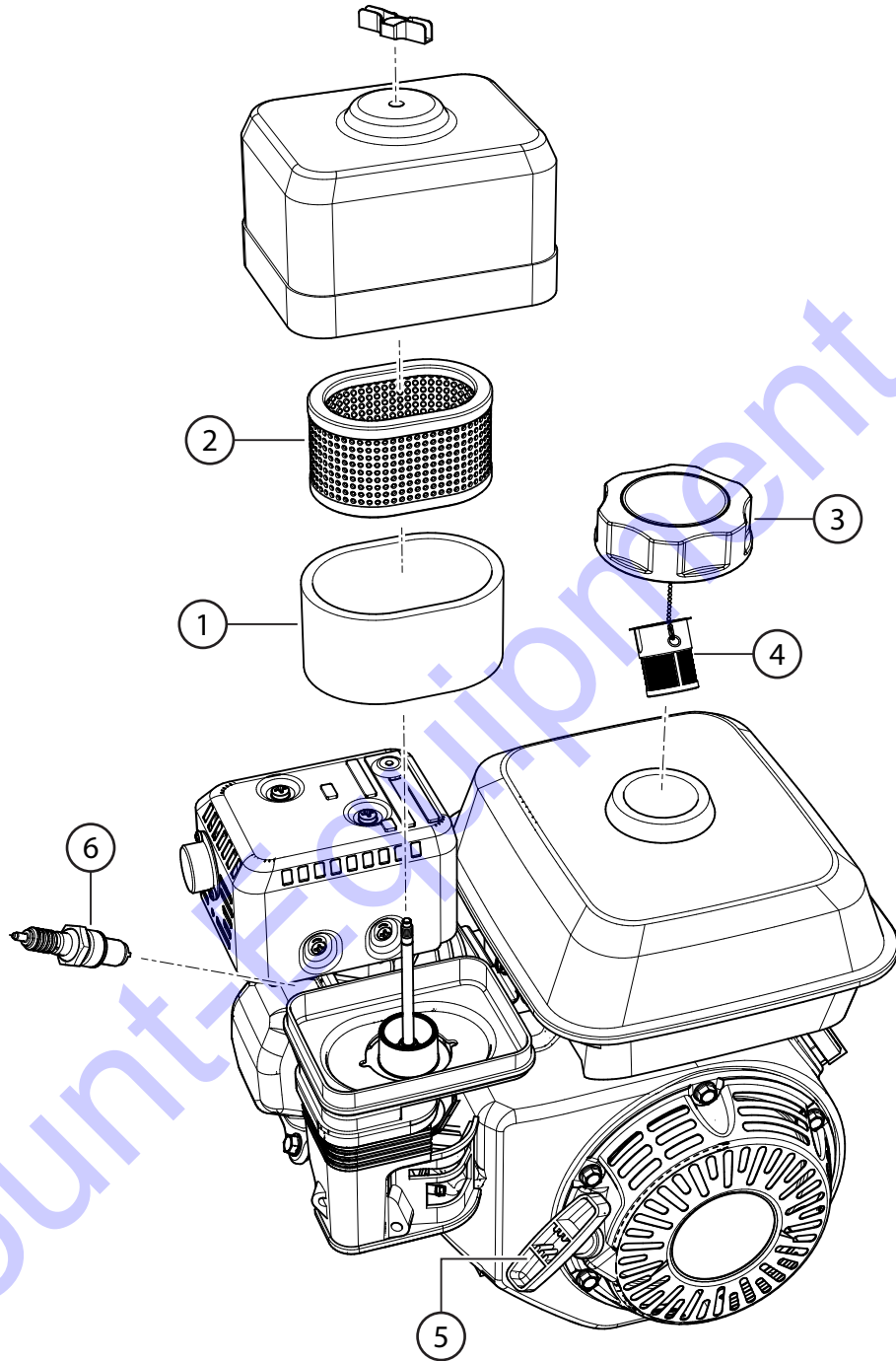

ENGINE SERVICE PARTS

<u>NO.</u>	<u>PART NO.</u>	<u>PART NAME</u>	<u>QTY.</u>	<u>REMARKS</u>
1	17218ZE3000	FILTER, OUTER	1	
2	17210ZE3010	AIR CLEANER ELEMENT	1	
3	17620Z0T305	TANK CAP, CHROME PLATED	1	
4	17672ZE2W01	FUEL FILTER	1	
5	28462ZE3W01	ROPE, RECOIL	1	
6	9807955846	SPARK PLUG, BPR5ES (NGK)	1	