

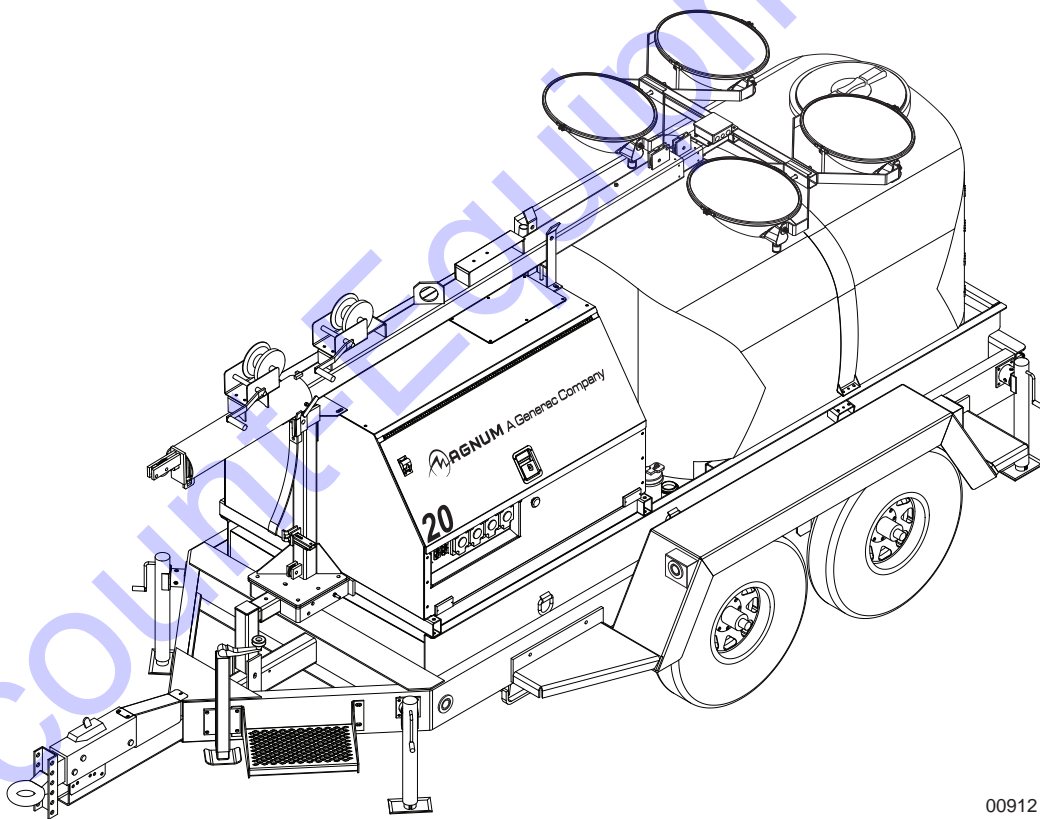

MAGNUM™

A Generac Company

COMBINATION LIGHT TOWER GENERATOR & WATER TRAILER MTT15 • MTT20 • MTT20CAN OPERATING MANUAL



00912



www.discount-equipment.com

Discount Equipment

Discount-Equipment.com is your online resource for commercial and industrial quality parts and equipment sales.

Locations:

Florida (West Palm Beach): [561-964-4949](tel:561-964-4949)

Outside Florida TOLL FREE: [877-690-3101](tel:877-690-3101)

Need parts? Check out our website at www.discount-equipment.com

Can't find what you need?

Click on this link: <http://www.discount-equipment.com/category/5443-parts/> and fill out the request form.

Please have the machine model and serial number available in order to help us get you the correct parts. One of our experienced staff members will get back to you with a quote for the right part that your machine needs.

We sell worldwide for the brands: Genie, Terex, JLG, MultiQuip, Mayco, Toro/Stone, Diamond Products, Magnum, Airman, Mustang, Power Blanket, Nifty Lift, Atlas Copco, Chicago Pneumatic, Allmand Brothers, Essick, Miller Spreader, Skyjack, Lull, Skytrak, Tsurumi, Husquvarna/Target, Whiteman-Concrete/Mortar, Stow-Concrete/Mortar, Baldor, Wacker, Sakai, Snorkel, Upright, Mi-T-M, Sullair, Neal, Basic, Dynapac, MBW, Weber, Bartell, Bennar Newman, Haulotte, Ditch Runner, Blaw-Knox, Himoina, Best, Buddy, Crown, Edco, Wyco, Bomag, Laymor, Terremite, Barreto, EZ Trench, Takeuchi, Basic, Bil-Jax, Curtis, Gehl, Heli, Honda, ICS/PowerGrit, Puckett, Waldon, ASV, IHI, Partner, Imer, Clipper, MMD, Koshin, Rice, Gorman Rupp, CH&E, Cat Pumps, Comet, General Pump, Giant, AMida, Coleman, NAC, Gradall, Square Shooter, Kent, Stanley, Tamco, Toku, Hatz, Kohler, Robin, Wisconsin, Northrock, Oztec, Toker TK, Rol-Air, Small Line, Wanco, Yanmar

New Equipment - Used Equipment - Rental Equipment - Parts and Accessories

Discount Equipment

www.discount-equipment.com

561-964-4949

Parts: wbparts@Discount-Equipment.com

Sales: info@Discount-Equipment.com

INTRODUCTION

This manual provides information and procedures to safely operate and maintain the Magnum Power Products LLC unit. For your own safety and protection from physical injury, carefully read, understand, and observe the safety instructions described in this manual. Keep a copy of this manual with the unit at all times. *Magnum Power Products LLC reserves the right to change any portion of this information without notice.*

Read all of the manuals included with the unit. Each manual details specific information regarding items such as setup, use and service requirements. An engine operator's manual provides detailed operation and maintenance procedures for the engine. Additional copies of the engine operator's manual are available from the engine manufacturer.

DO NOT MODIFY or use this equipment for any application other than which it was designed for.

Magnum Power Products LLC recommends that a trained and licensed professional perform all electrical wiring and testing functions. Installation should be in compliance with the National Electrical Code (NEC), state and local regulations and Occupational Safety and Health Association (OSHA) guidelines.

Engine Make: _____

Engine Serial Number: _____

Engine Model Number: _____

Generator Make: _____

Generator Model Number: _____

Generator Serial Number: _____

Unit Model Number: _____

Unit Serial Number: _____

▲ WARNING

CALIFORNIA PROPOSITION 65 WARNING: Diesel engine exhaust and some of its constituents are known to the state of California to cause cancer, birth defects and other reproductive harm.

TABLE OF CONTENTS

	Page
INTRODUCTION	2
SAFETY NOTES	5
OPERATING SAFETY	5
ENGINE SAFETY	6
SERVICE SAFETY	7
TOWING SAFETY	7
REPORTING TRAILER SAFETY DEFECTS	8
SAFETY SYMBOL SUMMARY	9
SPECIFICATIONS - MTT15	10
SPECIFICATIONS - MTT20	11
SPECIFICATIONS - MTT20CAN	12
UNIT DIMENSIONS	13
UNIT SERIAL NUMBER LOCATIONS	14
COMPONENT LOCATIONS	15
LIGHT TOWER SET UP	16
RAISING THE MAST	17
RAISING THE MAST WITH ELECTRIC WINCH OPTION	18
MAIN CONTROL PANEL	19
PRESTART CHECKLIST	19
EMERGENCY STOP SWITCH	20
STARTING THE UNIT	20
AUTOMATIC SHUTDOWN	21
LIGHT OPERATION	21
VOLTAGE REGULATION	22
DERATING FOR ALTITUDE	22
WET STACKING	22
RECEPTACLE PANEL	22
SHUTTING DOWN THE UNIT	22
USING THE WATER SUPPLY	23
LOWERING THE MAST - MANUAL	24
LOWERING THE MAST - ELECTRIC WINCH OPTION	24
REMOVING THE LIGHTS FOR TRANSPORTATION	25
TOWING THE UNIT	25
LIFTING THE UNIT	26
GENERAL MAINTENANCE	26
BASIC MAINTENANCE SCHEDULE - ISUZU ENGINE	27
BASIC MAINTENANCE SCHEDULE - MITSUBISHI ENGINE	28
WINCH USE, OPERATION & MAINTENANCE - MANUAL	28
WINCH USE, OPERATION & MAINTENANCE - ELECTRIC	29
JACK MAINTENANCE	30
TRAILER WHEEL BEARINGS	30
LOWER RADIATOR HOSE HEATER OPTION - USE AND MAINTENANCE	31
TROUBLESHOOTING THE LIGHTS	31
TROUBLESHOOTING AUTOMATIC SHUTDOWN CONDITIONS	32
MAST LIGHT CONNECTIONS	33
AC WIRING DIAGRAM - MTT15	34
AC WIRING DIAGRAM - MTT20, MTT20CAN	35
AC WIRING DIAGRAM - RECEPTACLE PANEL	36
AC WIRING DIAGRAM - RECEPTACLE PANEL OPTIONS (1 OF 2)	37
AC WIRING DIAGRAM - RECEPTACLE PANEL OPTIONS (2 OF 2)	38
DC WIRING DIAGRAM - MTT15	39
DC WIRING DIAGRAM - MTT20, MTT20CAN	40
DC WIRING DIAGRAM - ELECTRIC WINCH FOR MTT15	41
DC WIRING DIAGRAM - ELECTRIC WINCH FOR MTT20, MTT20CAN	42
DC WIRING DIAGRAMS FOR OPTIONS EQUIPMENT	43
TRAILER LIGHTS WIRING DIAGRAM - MTT15	44

TRAILER LIGHTS WIRING DIAGRAM - MTT20, MTT20CAN..... 45
ELECTRIC BRAKES WIRING DIAGRAM - MTT15 46
SERVICE LOG 47

Discount-Equipment.com

SAFETY NOTES



This is the safety alert symbol. It is used to alert you to potential personal injury hazards. Obey all safety messages that follow this symbol to avoid possible injury or death.

This manual contains DANGERS, WARNINGS, CAUTIONS, NOTICES and NOTES which must be followed to prevent the possibility of improper service, damage to the equipment, personal injury or death. The following formatting options will apply when calling the readers attention to the DANGERS, WARNINGS, CAUTIONS, NOTICES and NOTES.

▲ DANGER

INDICATES A HAZARDOUS SITUATION WHICH, IF NOT AVOIDED, WILL RESULT IN DEATH OR SERIOUS INJURY.

▲ WARNING

Indicates a hazardous situation which, if not avoided, could result in death or serious injury.

▲ CAUTION

Indicates a hazardous situation which, if not avoided, could result in minor or moderate injury.

NOTICE

Indicates a hazardous situation which, if not avoided, could result in property or equipment damage.

Note: Notes contain additional information important to a procedure and will be found within the regular text body of this manual.

OPERATING SAFETY



Before using the unit be sure to read and understand all of the instructions. This equipment was designed for specific applications; **DO NOT** modify or use this equipment for any application other than which it was designed for. Equipment operated improperly or by untrained personnel can be dangerous.

Read the operating instructions and familiarize yourself with the location and proper use of all instruments and controls. Inexperienced operators should receive instruction from someone familiar with the equipment before being allowed to operate or set up the unit. The following points should be practiced at all times:

- The area immediately surrounding the unit should be dry, clean, and free of debris.
- Position and operate the unit on a firm, level surface.
- **NEVER** start a unit in need of repair.
- **ALWAYS** lower the mast when not in use, or if high winds or electrical storms are expected in the area.
- Make certain the unit is well grounded and securely fastened to a good earthen ground. Follow the National Electrical Code (NEC), state and local regulations.
- The mast extends up to 31.5 ft (9.6m). **ALWAYS** make sure the area above the unit is open and clear of overhead wires and obstructions.
- Keep area around the unit clear of people while raising and lowering the mast.
- Keep all body parts, clothing, and other loose items clear of winch and cable during operation and while in tension.
- Bulbs become extremely hot during use. Allow bulb and light fixture to cool 10-15 minutes before handling.
- **NEVER** raise, lower or turn mast while unit is operating.

- If for any reason any part of the mast hangs up or winch cable develops slack while raising or lowering the mast, **STOP** immediately and contact an authorized service representative.
- **NEVER** remove safety pin or pull mast locking pin while the mast is up.
- **NEVER** use the unit if insulation on electrical cord is cut or worn through.
- **NEVER** operate the lights without protective lens cover in place or with a lens cover that is cracked or damaged.
- Only use mild soap and water to clean the lens covers. Other chemicals may have an adverse effect on the glass.
- **NEVER** operate a unit while tired, distracted, or under the influence of drugs or alcohol.
- **NEVER** use water in the supply tank for human consumption.
- **ALWAYS** keep the water tank cover in place. Stay out of tank.
- **DO NOT** drive over the hoses while they are pressurized or while the pump is running.
- **NEVER** leave the unit unattended while the pump is running.

ENGINE SAFETY



Internal combustion engines present special hazards during operation and fueling. Failure to follow the safety guidelines described below could result in severe injury or death. Read and follow all safety warnings described in the engine operator's manual. A copy of this manual was supplied with the unit when it was shipped from the factory.

- **DO NOT** run engine indoors or in an area with poor ventilation unless exhaust hoses are used. Diesel engine exhaust contains carbon monoxide, a deadly, odorless and colorless gas which, if inhaled, can cause nausea, fainting or death. Make sure engine exhaust cannot seep into closed rooms or ventilation equipment.
- **DO NOT** operate the unit on a combustible surface.
- **DO NOT** fill fuel tank near an open flame, while smoking, or while engine is running. **DO NOT** fill tank in an enclosed area with poor ventilation.
- **DO NOT** operate with the fuel tank cap loose or missing.
- **DO NOT** touch or lean against hot exhaust pipes or engine cylinders.
- **DO NOT** clean air filter with gasoline or other types of low flash point solvents.
- **DO NOT** remove engine coolant cap while engine is hot.
- **DO NOT** operate the unit without a functional exhaust system. Prolonged exposure to sound levels in excess of 85 dB(A) can cause permanent hearing loss. Wear hearing protection when working around a running engine.
- Keep area around exhaust pipes and air ducts free of debris to reduce the chance of an accidental fire.
- Batteries contain sulfuric acid which can cause severe injury or death. Sulfuric acid can cause eye damage, burn flesh or eat holes in clothing. Protective eye wear and clothing are necessary when working on or around the battery. Always disconnect the negative (-) battery cable from the corresponding terminal before performing any service on the engine or other components.
- Shut the engine down if any of the following conditions exist during operation:
 1. Noticeable change in engine speed.
 2. Loss of electrical output and/or pumping output.
 3. Equipment connected to the generator overheats.
 4. Sparking occurs.
 5. Engine misfires or there is excessive engine/generator vibration.
 6. Protective covers are loose or missing.
 7. If the ambient air temperature is above 120°F (49°C).

SERVICE SAFETY



This unit uses high voltage circuits capable of causing serious injury or death. Only a qualified electrician should troubleshoot or repair electrical problems occurring in this equipment.

- Before servicing, make sure the Control Power switch and circuit breakers are in the OFF (O) position, and the negative terminal on the battery is disconnected. **NEVER** perform even routine service (oil/filter changes, cleaning, etc.) unless all electrical components are shut down.
- **NEVER** allow water to accumulate around the base of the unit. If water is present, **DO NOT** service.
- **NEVER** service electrical components if clothing or skin is wet. If the unit is stored outside, check the engine and generator for any moisture and dry the unit before use.
- **NEVER** wash the unit with a power washer or high pressure hose.
- Open the main circuit breaker before disconnecting battery cables.
- Keep all body parts, clothing, and other loose items away from moving parts on the unit.
- Make sure slings, chains, hooks, ramps, jacks, and other types of lifting devices are attached securely and have enough weight-bearing capacity to lift or hold the unit safely. Always remain aware of the position of other people around when lifting the unit.
- **NEVER** start the unit under load. The circuit breakers must be in the "OFF" position when starting the unit.
- **ALWAYS** disconnect the negative (-) battery cable from the corresponding terminal before performing any service on the engine, generator or any other components. Remove the negative (-) battery cable from the corresponding terminal if the unit is to be stored or transported.
- Replace all guards and safety devices immediately after servicing.
- Wear heavy leather gloves when handling winch cables. Never let cables slip through bare hands.

TOWING SAFETY



Towing a trailer requires care. Both the trailer and vehicle must be in good condition and securely fastened to each other to reduce the possibility of an accident. Some states require that large trailers be registered and licensed, contact your local Department of Transportation office to check on license requirements for your particular unit. Reduce speed when the tank is filled with water. The tank is not baffled. There will be a noticeable water surge in the tank under heavy braking.

- Check that the hitch and coupling on the towing vehicle are rated equal to, or greater than, the trailer's Gross Vehicle Weight Rating (GVWR).
- Check tires on trailer for tread wear, inflation, and condition.
- **NEVER** tow trailer using defective parts. Inspect the hitch and coupling for wear or damage.
- Make sure the trailer hitch and the coupling are compatible. Make sure the coupling is securely fastened to the vehicle.
- Connect safety chains in a crossing pattern under the tongue and **ATTACH THE BREAKAWAY CABLE TO THE REAR BUMPER OF THE TOWING VEHICLE**. Do not attach the cable to the trailer hitch.
- Make sure directional and brake lights on the trailer are connected and working properly.
- Check that all lug nuts holding wheels on are tight and none are missing.
- Maximum recommended speed for highway towing is 45 mph (72 km/h). Recommended off-road towing speed is not to exceed 10 mph (16 km/h) or less, depending on terrain.
- When towing, maintain extra space between vehicles and avoid soft shoulders, curbs and sudden lane changes. If you have not pulled a trailer before, practice turning, stopping, and backing up in an area away from heavy traffic.

- Towing the unit with water in the tank will adversely affect handling of towing vehicle, specifically maneuvering corners, accelerating, and braking. Ensure operator has experience with towing unit.
- Maximum recommended towing speeds for the unit are as follows:

With the tank empty, improved road:55 mph (89 km/h)

With the tank full, improved road:45 mph (72 km/h)

With the tank 1/2 full, improved road:45 mph (72 km/h)

Any towing on unimproved roads:20 mph (32 km/h) or less

- Before towing the trailer, check that the weight of the trailer is equal across all tires. A large angle between the trailer and tow vehicle will cause more weight to be carried by one axle, which could cause premature wear on the tires and axles and cause potentially unsafe operating conditions. Adjust the angle of the trailer tongue to keep the trailer as level as possible.
- The trailer is equipped with hydraulic surge brakes or electric surge brakes. Check the operation of the brakes by braking the vehicle at a slow speed before entering traffic. Both the trailer and the vehicle should brake smoothly. If the trailer seems to be pushing, check the level in the surge brake fluid reservoir.

REPORTING TRAILER SAFETY DEFECTS

If you believe your trailer has a defect which could cause a crash or could cause injury or death, you should immediately inform the National Highway Traffic Safety Administration (NHTSA) in addition to notifying Magnum Power Products LLC.

If NHTSA receives similar complaints, it may open an investigation; and if it finds that a safety defect exists in a group of vehicles, it may order a recall and remedy campaign. However, NHTSA cannot become involved in an individual problem between you, your dealer, or Magnum Power Products LLC.





















To contact NHTSA, you may either call the Auto Safety Hotline toll-free at 1-888-327-4236 (TTY:1-800-424-9153), go to <http://www.safercar.gov>; or write to:

Administrator
NHTSA
1200 New Jersey Avenue S.E.
Washington, DC 20590

You can also obtain other information about motor vehicle safety from <http://www.safercar.gov>.

SAFETY SYMBOL SUMMARY

This equipment has been supplied with numerous safety and operating decals. These decals provide important operating instructions and warn of dangers and hazards. Replace any missing or hard-to-read decals and use care when washing or cleaning the unit. Decal placement and part numbers can be found in the parts manual. Below is a summary of the intended meanings for the symbols used on the decals.

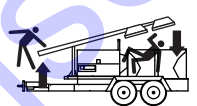
	Safety alert symbol; used to alert you to potential personal injury hazards.		Asphyxiation hazard; operate in well ventilated area.
	Hot surface(s) nearby.		Dangerous voltage may be present.
	Belt/entanglement hazard; keep body parts clear of this area.		Use clean diesel fuel only.
	Fan hazard; keep body parts clear of this area.		Burn/scald hazard; pressurized steam.
	Crush hazard; keep body parts clear of this area.		Read and understand the supplied operator's manual before operating unit.
	Ultraviolet radiation hazard; operate only with lens intact.		Unit electrical ground.
	Stop engine before fueling.		Do not step on this surface.
	Fire/explosion hazard; keep open flames away from unit.		Do not lift.
	Do not stand on this surface.		Stay out of tank.
	Do not drink the water.		Contact with overhead electrical power lines will cause serious injuries or death.
	Stand clear while mast is being operated.		

00913

SPECIFICATIONS - MTT15

MAGNUM MODEL

MTT15

Engine

Make/Brand	Mitsubishi
Model	S4L2-W461ML
EPA Tier	4f
Horsepower - prime hp (kW)	23.5 (17.5)
Horsepower - standby hp (kW)	24.7 (18.4)
Operating Speed rpm	1800
Displacement in³ (L)	107.40 (1.76)
Cylinders - qty	4
Fuel Consumption - 100% prime gph (Lph)	1.30 (4.92)
Battery Type - Group Number	24
Battery Voltage (Quantity per Unit)	12V (1)
Battery Rating	720 CCA

Generator

Make/Brand	Marathon Electric
Model	333CSA3024
Type, Insulation	Brushless, F

Generator Set (Engine/Generator)

1Ø - Standby kW (kVA)	14.0 (14.0)
Amps - 1Ø Standby - 240V A	58
1Ø - Prime kW (kVA)	13.0 (13.0)
Amps - 1Ø Prime - 240V A	54
Frequency Hz	60
Power Factor	1 (1Ø)

Pump

Make/Model	SHURFlo
Flow Rate gpm (Lpm)	3.3 (12.5)
Flow Rate at Hose Bibb gpm (Lpm)	3.0 (11.4)

Weights

Dry Weight lbs (kg)	4702 (2133)
Operating Weight lbs (kg)	10442 (4736)

Capacities

Fuel Tank Volume gal (L)	246 (931)
Usable Fuel Volume gal (L)	229 (867)
Water Tank Volume gal (L)	500 (1895)
Maximum Run Time hrs	176

Lighting

Lighting Type	Metal Halide
Ballast Type	Coil & Core
Lumens	440,000
Coverage acres (m²)	5-7 (20,234 - 28,328)

AC Distribution

Circuit Breaker Size	100
Voltage Selection	N/A
Voltage Regulation	+/-1%
Voltages Available 1Ø	120, 240
Voltages Available 3Ø	N/A

Trailer

Number of Axles	2
Capacity - Axle Rating lbs (kg)	6000 (2722)
Tire Size in	16
Brakes	Surge
Hitch - Standard	3" Ring
Maximum Tire Pressure psi	75

Specifications are subject to change without notice.

SPECIFICATIONS - MTT20

MAGNUM MODEL

MTT20

Engine

Make/Brand.....	Isuzu
Model	4LE1NYGV-03
.....	4LE1NYGV-03E
EPA Tier	4i
Horsepower - prime hp (kW)	32.1 (23.9)
Horsepower - standby hp (kW)	35.3 (26.3)
Operating Speed rpm	1800
Displacement in³ (L)	134 (2.2)
Cylinders - qty	4
Fuel Consumption - 100% prime gph (Lph)	1.80 (6.81)
Battery Type - Group Number	24
Battery Voltage (Quantity per Unit)	12V (1)
Battery Rating	720 CCA

Generator

Make/Brand.....	Marathon Electric
Model	334CSA3028
Type, Insulation	Brushless, H

Generator Set (Engine/Generator)

1Ø - Standby kW (kVA)	20.0 (20.0)
Amps - 1Ø Standby - 240V A	83
1Ø - Prime kW (kVA)	19.0 (19.0)
Amps - 1Ø Prime - 240V A	79
Frequency Hz	60
Power Factor.....	1 (1Ø)

Pump

Make/Model	SHURFlo
Flow Rate gpm (Lpm)	3.3 (12.5)
Flow Rate at Hose Bibb gpm (Lpm)	3.0 (11.4)

Weights

Dry Weight lbs (kg)	5160 (2341)
Operating Weight lbs (kg)	10900 (4944)

Capacities

Fuel Tank Volume gal (L)	246 (931)
Usable Fuel Volume gal (L)	229 (867)
Water Tank Volume gal (L)	500 (1895)
Maximum Run Time hrs	127

Lighting

Lighting Type.....	Metal Halide
Ballast Type.....	Coil & Core
Lumens	440,000
Coverage acres (m²).....	5-7 (20,234 - 28,328)

AC Distribution

Circuit Breaker Size	100
Voltage Selection	N/A
Voltage Regulation.....	+/-1%
Voltages Available 1Ø	120, 240
Voltages Available 3Ø	N/A

Trailer

Number of Axles.....	2
Capacity - Axle Rating lbs (kg)	6000 (2722)
Tire Size in	16
Brakes.....	Surge
Hitch - Standard	3" Ring
Maximum Tire Pressure psi	75

Specifications are subject to change without notice.

SPECIFICATIONS - MTT20CAN

MAGNUM MODEL

MTT20CAN

Engine

Make/Brand.....	Isuzu
Model	4LE1NYGV-03G
EPA Tier	4i
Horsepower - prime hp (kW)	32.1 (23.9)
Horsepower - standby hp (kW)	35.3 (26.3)
Operating Speed rpm	1800
Displacement in³ (L)	134 (2.2)
Cylinders - qty	4
Fuel Consumption - 100% prime gph (Lph)	1.80 (6.81)
Battery Type - Group Number	24
Battery Voltage (Quantity per Unit)	12V (1)
Battery Rating	720 CCA

Generator

Make/Brand.....	Marathon Electric
Model	334CSA3028
Type, Insulation	Brushless, H

Generator Set (Engine/Generator)

1Ø - Standby kW (kVA)	20.0 (20.0)
Amps - 1Ø Standby - 240V A	83
1Ø - Prime kW (kVA)	19.0 (19.0)
Amps - 1Ø Prime - 240V A	79
Frequency Hz	60
Power Factor.....	1 (1Ø)

Pump

Make/Model	SHURFlo
Flow Rate gpm (Lpm)	3.3 (12.5)
Flow Rate at Hose Bibb gpm (Lpm)	3.0 (11.4)

Weights

Dry Weight lbs (kg)	5160 (2341)
Operating Weight lbs (kg)	10900 (4944)

Capacities

Fuel Tank Volume gal (L)	246 (931)
Usable Fuel Volume gal (L)	229 (867)
Water Tank Volume gal (L)	500 (1895)
Maximum Run Time hrs	127

Lighting

Lighting Type.....	Metal Halide
Ballast Type.....	Coil & Core
Lumens	440,000
Coverage acres (m²).....	5-7 (20,234 - 28,328)

AC Distribution

Circuit Breaker Size	100
Voltage Selection	N/A
Voltage Regulation.....	+/-1%
Voltages Available 1Ø	120, 240
Voltages Available 3Ø	N/A

Trailer

Number of Axles.....	2
Capacity - Axle Rating lbs (kg)	6000 (2722)
Tire Size in	16
Brakes.....	Surge
Hitch - Standard	3" Ring
Maximum Tire Pressure psi	75

Specifications are subject to change without notice.

UNIT DIMENSIONS

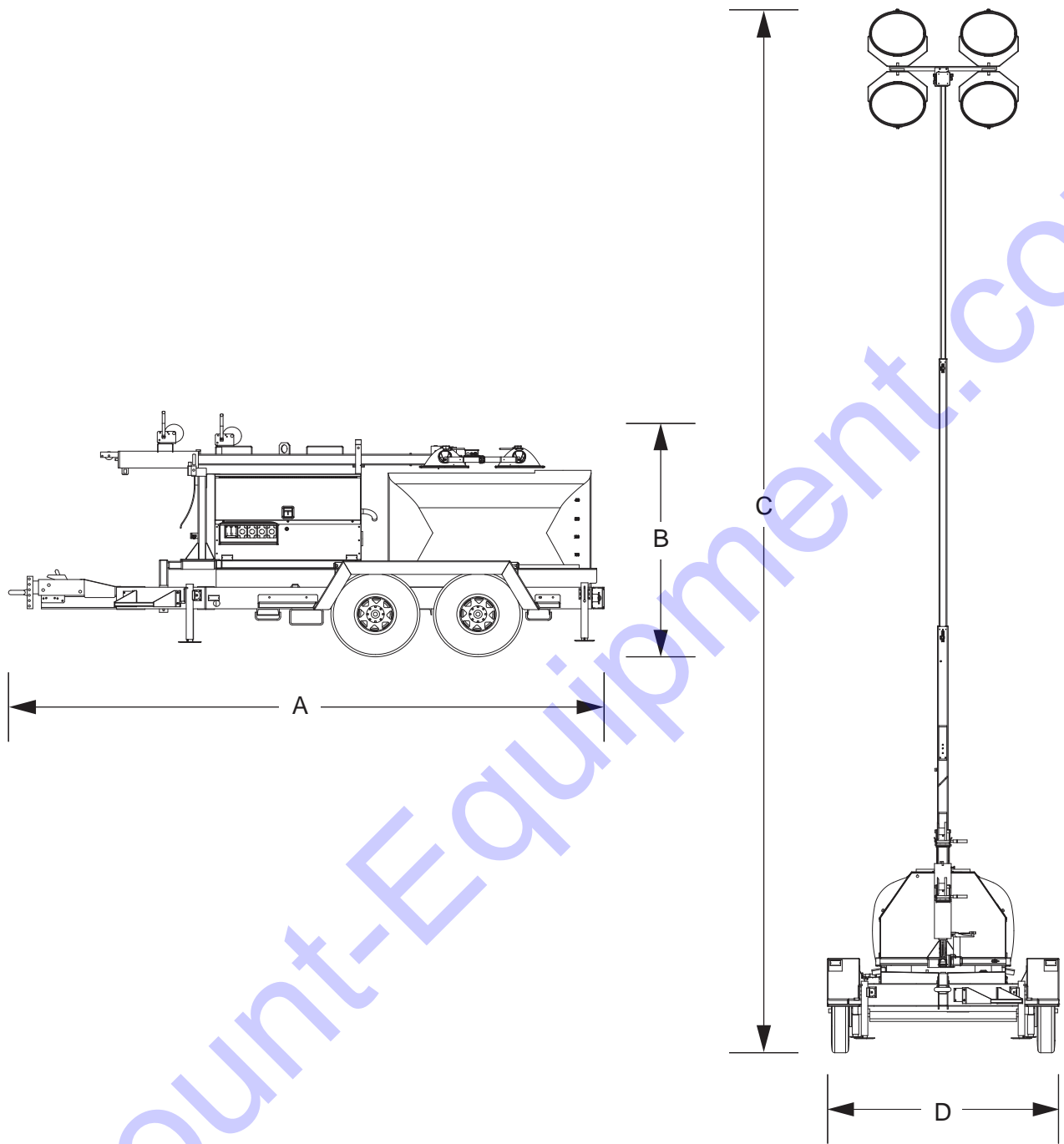

00217

	A	B	C	D
MTT15, MTT20, MTT20CAN	210 in (5.3 m)	83 in (2.1 m)	31.5 in (9.6 m)	86 in (2.18 m)

Specifications are subject to change without notice.

COMPONENT LOCATIONS

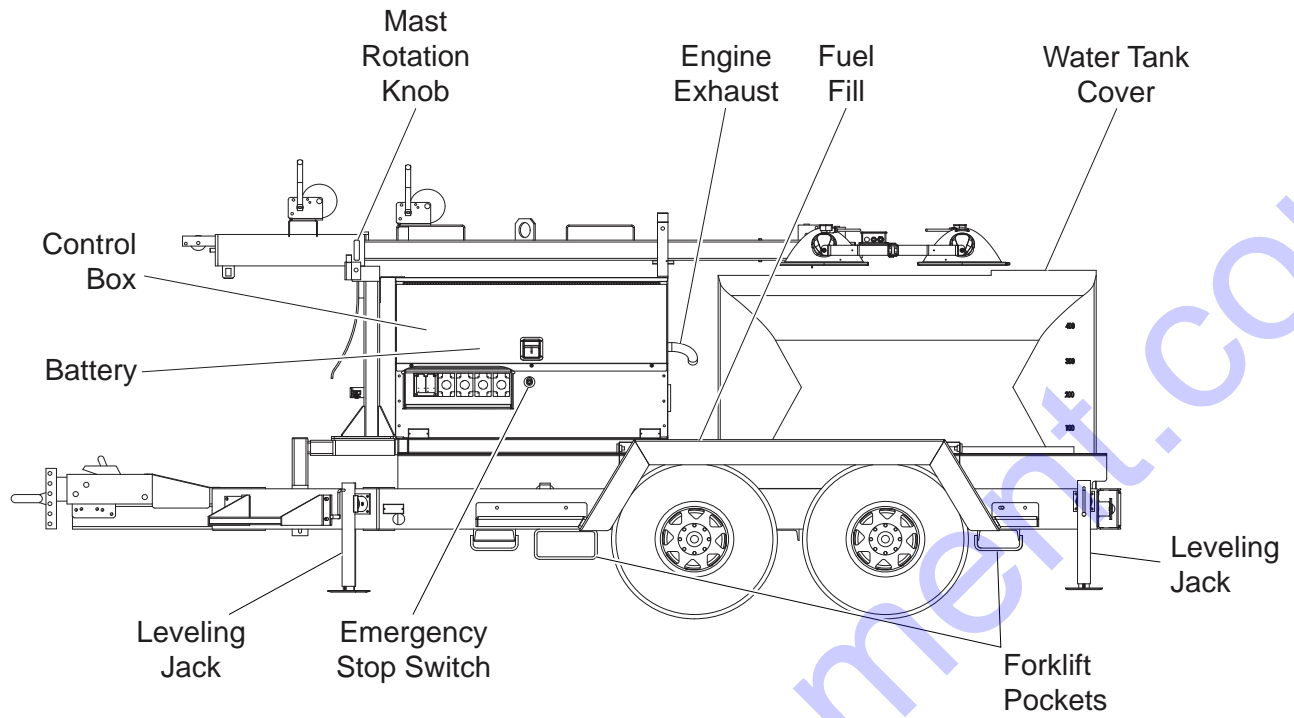

LEFT SIDE

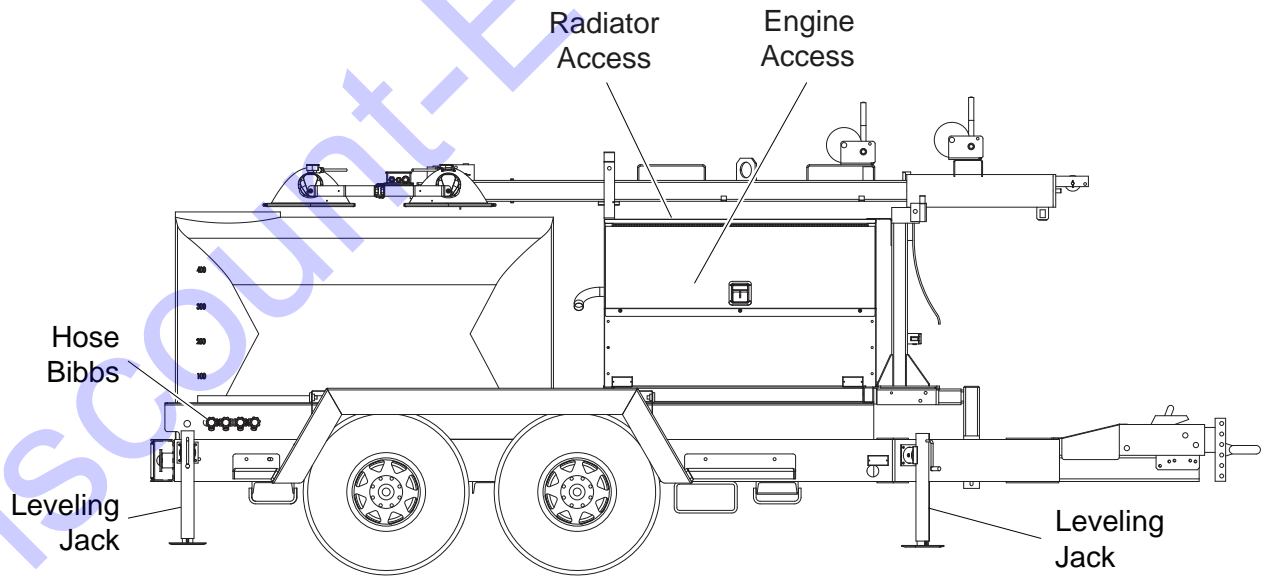

RIGHT SIDE

00113

LIGHT TOWER SET UP

1. For maximum light coverage, locate the unit at ground level or in a spot higher than the area being illuminated by the lamps.

▲ WARNING

The mast extends up to 31.5 ft (9.6 m). Make sure the area above the unit is open and clear of overhead wires and obstructions. Do not set up the unit if high winds or storms capable of producing lightning are expected in the area.

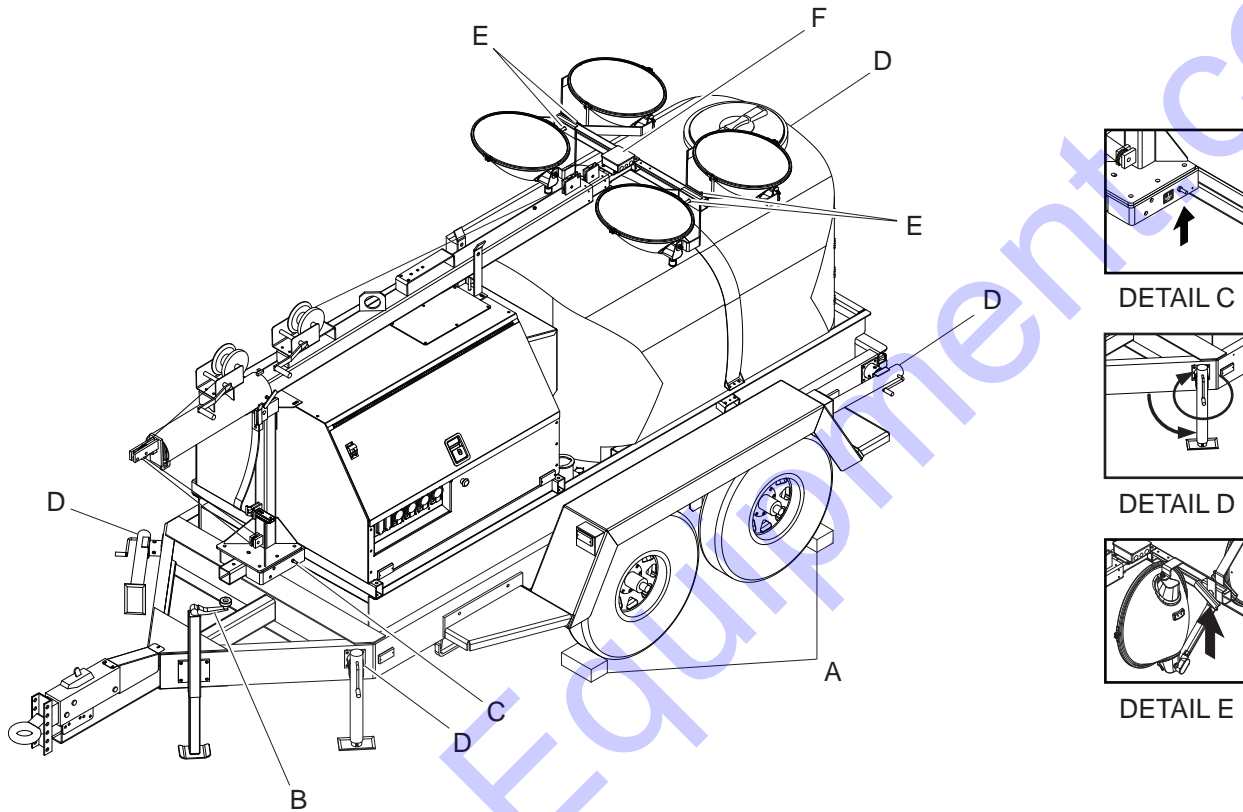

00915

2. Place the unit on firm ground that is relatively flat, then block the wheels to keep it from moving (A). This will make it easier to level the unit.
3. Turn the tongue jack handle clockwise to raise the trailer tongue off of the towing vehicle (B).
4. Connect a good earthen ground to the grounding stud on the frame at the base of the mast post (C).

Note: Refer to local codes for proper grounding requirements.

5. Pull the locking pins on the four leveling jacks (D), rotate them so the jack feet are toward the ground, and insert the locking pins again to secure the jacks. Adjust all four jacks by turning their handles clockwise until they are firmly in contact with the ground and the unit is as level as possible.
6. Before raising the mast it may be necessary to adjust the lamps. The lamps may be adjusted up, down, left or right by loosening the wing nuts on the trunnion (E) and aiming them in the desired direction. Tighten the hardware completely and make sure the lamps are connected to the junction box (F).

RAISING THE MAST

1. Set up and level the unit. Refer to *“Light Tower Set Up”* on page 16.

▲ WARNING

The unit must be leveled before raising the mast. Failure to level the unit will severely reduce the stability and could allow the unit to tip and fall.

2. Remove the mast cradle locking pin from the mast cradle (A).
3. Check the mast cables for excessive wear or damage. Make sure the cables are properly centered in each pulley (B). Check the electrical cord for damage.

▲ WARNING

Do not start the unit if insulation on the electrical cord is cut or worn through. Bare wires in contact with the mast or frame may energize the unit and cause electrocution. Repair or replace a damaged cord.

4. Make sure the area around the unit is clear before raising the mast to the vertical position.
5. Remove the safety pin from the mast lock bar (C). Using the handle for the lower mast winch (D), raise the mast until it is vertical and the tab on the mast is positioned into the mast lock. The mast lock bar should snap into place automatically. Secure the lock with the safety pin (E).

6. After the mast is up and locked into place, use the upper mast winch (F) to telescope the mast to the desired height. Extend the mast slowly, making sure the electrical cord is extending at the top sections of the mast. If, for any reason, the winch cable begins to develop slack or any of the mast sections get stuck, **STOP IMMEDIATELY** and contact an authorized service center.

▲ CAUTION

Do not extend the mast beyond the colored mark on the middle mast tube (G).

7. The mast can be rotated by loosening the mast rotation knob at the bottom of the mast (H). Turn the mast until the lights face in the desired direction and then tighten the knob.

▲ WARNING

Never raise or lower the mast while the unit is operating. Never remove the safety pin or release the mast lock while the mast is up. Releasing the lock will cause the mast to fall.

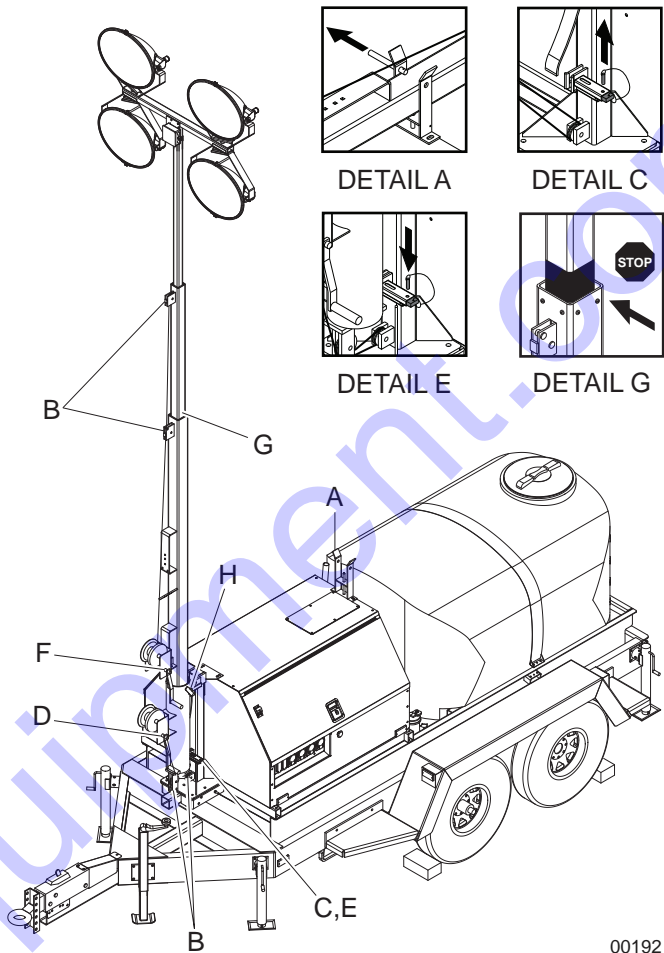

00192

RAISING THE MAST WITH ELECTRIC WINCH OPTION

1. Set up and level the unit. Refer to *“Light Tower Set Up”* on page 16.

▲ WARNING

The unit must be leveled before raising the mast. Failure to level the unit will severely reduce the stability and could allow the unit to tip and fall.

2. Remove the mast cradle locking pin from the mast cradle (A).
3. Check the mast cables for excessive wear or damage. Make sure the cables are properly centered in each pulley (B). Check the electrical cord for damage.

▲ WARNING

Do not start the unit if insulation on the electrical cord is cut or worn through. Bare wires in contact with the mast or frame may energize the unit and cause electrocution. Repair or replace a damaged cord.

4. Make sure the area around the unit is clear before raising the mast to the vertical position.
5. Remove the safety pin from the mast lock bar (C). Press the lower winch control switch (D) upward to raise the mast into the vertical position. Hold the switch until the mast lock is engaged. The mast lock bar should snap into place automatically. Secure the lock with the safety pin (E).

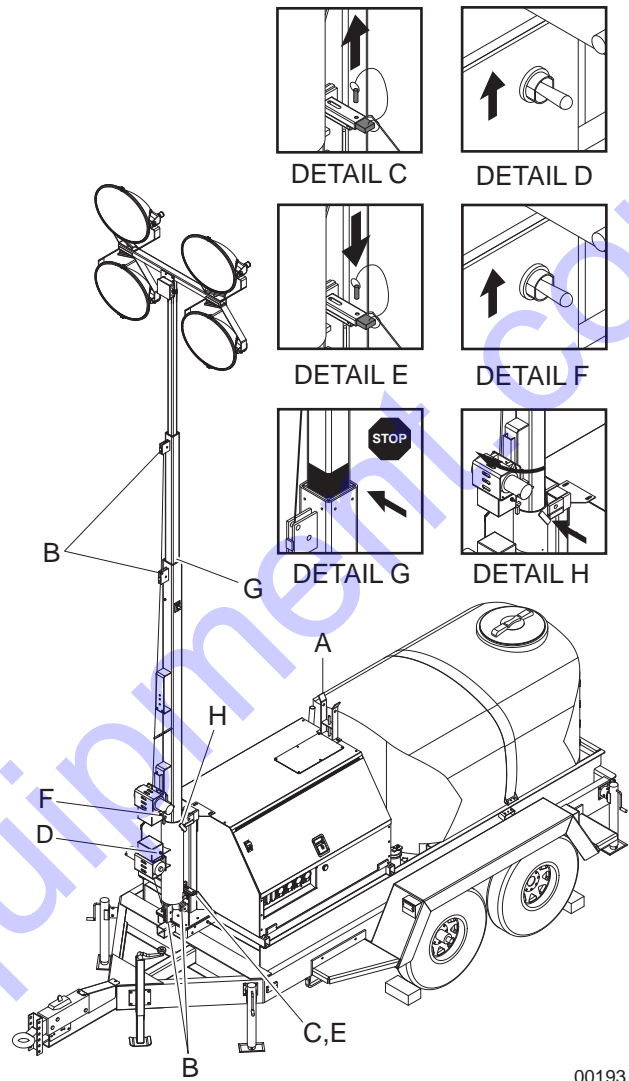

00193

Note: On units with the electric winch option, a limit switch on the mast tube will disconnect power to the lower electric winch to prevent deadheading the winch.

6. Press and hold the upper winch control switch (F) upward to telescope the mast to the desired height. Extend the mast slowly, making sure that the coiled electrical cord is extending at the top sections of the mast. If, for any reason, the winch cable begins to develop slack or any of the mast sections get stuck, **STOP IMMEDIATELY** and contact an authorized service center.

▲ CAUTION

Do not extend the mast beyond the colored mark on the middle mast tube (G). On units equipped with the electric winch option, a limit switch on the main mast section will disconnect power to the upper electric winch to prevent overextending the mast.

7. The mast can be rotated by loosening the locking knob at the bottom of the mast (H). Turn the mast until the lights face in the desired direction and then tighten the knob.

▲ WARNING

Never raise or lower the mast while the unit is operating. Never remove the safety pin or release the mast lock while the mast is up. Releasing the lock will cause the mast to fall.

MAIN CONTROL PANEL

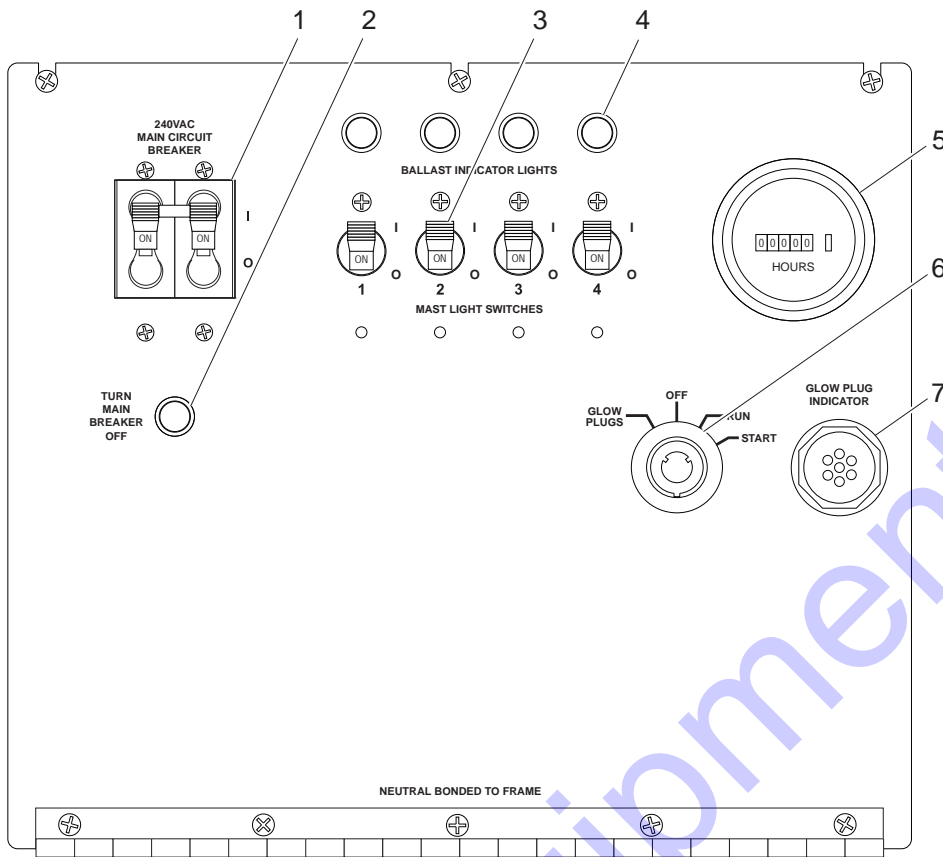

00168

- 1. MAIN CIRCUIT BREAKER:** This 240V (100A) breaker will disconnect power to the lights and receptacles.
- 2. CIRCUIT BREAKER INDICATOR LIGHT:** This light indicates that the main circuit breaker must be opened (switched off) before starting the engine.
- 3. LIGHT SWITCHES:** One circuit breaker is supplied for each light.
- 4. BALLAST INDICATOR LIGHTS:** Indicates power from the ballast to each light.
- 5. ENGINE HOUR METER:** Keeps track of engine hours for service.
- 6. CONTROL POWER SWITCH:** Keyed switch operates glow plugs and starts and stops engine.
- 7. GLOW PLUG INDICATOR:** Indicates operation of the engine glow plugs.

PRESTART CHECKLIST

Before starting the unit, all items in the prestart checklist must be completed.

- Read and understand **ALL** safety sections at the beginning of this manual.
- Ensure all maintenance procedures are up to date. For more information, refer to *"General Maintenance"* on page 26 and Basic Maintenance Schedules beginning on page 27.
- The unit must be level.
- The unit must be dry. Check for any water inside, on, or near the unit; dry if needed.
- Ensure the unit is properly grounded to a good earthen ground. Installation should be in compliance with the National Electrical Code (NEC), state and local regulations.
- Switch the Control Power switch to the OFF (O) position.
- Switch all circuit breakers to the OFF (O) position.

- Inspect all electrical cords; repair or replace any that are cut, worn, or bare.
- Ensure all winch cables are in good condition and centered on each pulley. Do not use if cables are kinked or beginning to unravel.
- Check oil, coolant, and fuel levels. For more information, refer to *“General Maintenance” on page 26.*
- Ensure engine battery connections are secure.
- Turn the battery disconnect switch on, if equipped.
- Check the engine fan belt tension and condition.
- Check the engine fan belt guard.
- Check the engine exhaust system for loose or rusted components.
- Ensure all covers are in place and secure.
- Ensure the emergency stop switch is pulled out.

EMERGENCY STOP SWITCH

The unit is equipped with one emergency stop switch. For location of the emergency stop switch, refer to *“Component Locations” on page 15.* The red button is clearly labeled “EMERGENCY STOP.” The switch can be accessed and activated with all doors closed and locked.

Activate the emergency stop switch by pushing the button in until it locks down. This will open the fuel circuit, shutting down the engine. The switch will remain locked until it is pulled out.

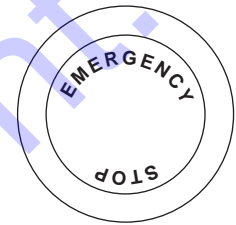

00230

NOTICE

Use the emergency stop switch only when the unit must be shut down immediately. For any other shut down, refer to *“Shutting Down the Unit” on page 22.*

STARTING THE UNIT

1. Check that the main circuit breaker and individual circuit breakers for each of the lights are in the “OFF/O” position.

Note: When the red “TURN MAIN BREAKER OFF” light is illuminated, the main circuit breaker must be turned OFF (O).

CIRCUIT BREAKERS

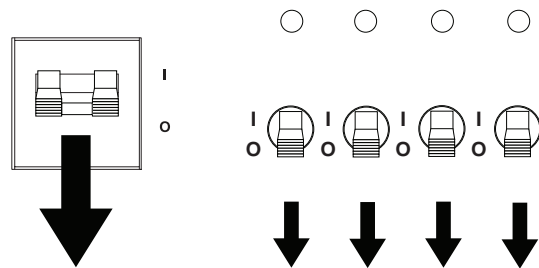

00202

2. Turn the key on the Control Power switch to the left “GLOW PLUG” position and hold the key in place for five seconds, or until the glow plug indicator turns red. As soon as it is glowing, turn the key to the right “START” position and hold it until the engine cranks and starts running. Release the key, it will move to the “RUN” position.

Note: For cold weather conditions, refer to the engine operator’s manual for appropriate glow plug interval.

ACTIVATE GLOW PLUG

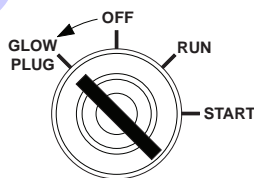

CRANK ENGINE TO START

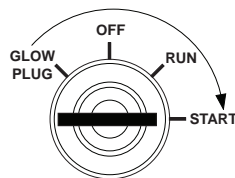

RELEASE KEY

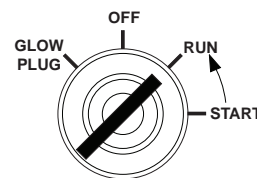

00203

NOTICE

Do not crank the engine longer than 10 seconds at a time. If the engine will not start, wait

30 seconds to allow the starter motor to cool and then repeat the starting procedure.
Excessive cranking will cause damage to the starter.

Note: If oil pressure is not obtained within 15 seconds after the key is switched to the "RUN" position, the low oil automatic shutdown will turn off the fuel supply, stopping the engine. Check the oil level and turn the key to the "OFF" position to reset the oil pressure timer before attempting to restart the engine.

3. Once the engine is running, allow it to reach normal operating temperature before switching on any loads.

AUTOMATIC SHUTDOWN

This unit is equipped with a low oil pressure and high coolant temperature automatic shutdown system. This system will automatically shut off the fuel supply to stop the engine if oil pressure drops too low or the engine exceeds normal operating temperature. Return the Control Power switch to the OFF (O) position to reset the unit after you have determined the cause of the shutdown.

LIGHT OPERATION

▲ WARNING

NEVER OPERATE THE LIGHTS WITHOUT THE PROTECTIVE LENS COVER, OR WITH A LENS COVER THAT IS CRACKED OR DAMAGED. The bulbs in the light fixtures produce high temperatures and operate under pressure. A broken or missing lens cover could cause the bulbs to shatter, causing injury.

1. Once the engine is up to temperature and running smoothly, switch the main circuit breaker (A) to the ON (I) position.
2. With the main circuit breaker on, switch each individual circuit breaker for the lights (B) to ON (I), one at a time.
3. The ballast indicator lights (C) will come on and continue to get brighter as the lights warm up, and then remain on. This confirms that power is coming from the ballasts to the lights.
4. If an indicator light does not come on, the ballast may need to be serviced. If the indicator light comes on and stays lit, but the related light is not illuminated, check the bulb or the mast wiring. Refer to "[Troubleshooting the Lights](#)" on page 31.
5. The lights require a warm up period of 5-15 minutes before they reach full output. If the lights are shut down, they require a cool down period of approximately 10 minutes before they can be switched on again.
6. The light tower uses four 1000W bulbs. When checking or replacing the bulbs, wipe them with a clean cloth to avoid leaving any grease, oil residue or fingerprints on the glass. Any residue can create a hot spot on the bulb, causing premature bulb failure.

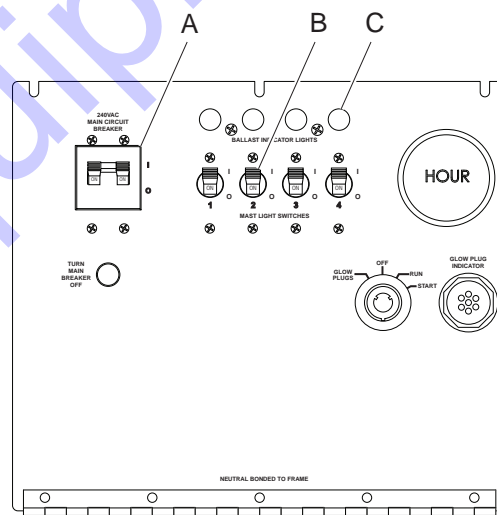

00148

▲ CAUTION

Bulbs become extremely hot when in use. Allow bulb fixture to cool 10-15 minutes before handling or lowering the mast.

VOLTAGE REGULATION

Units are equipped with an electronic voltage regulator. The voltage regulator controls the output of the generator by regulating the current into the exciter field. The regulator has three screwdriver adjustable potentiometers that may be adjusted for voltage, stability and voltage roll-off (U/F). The voltage regulator is adjusted before shipment from the factory. Contact Magnum Power Products LLC for additional information before attempting to adjust the voltage regulator.

DERATING FOR ALTITUDE

All units are subject to derating for altitude and temperature; this will reduce the available power for operating tools and accessories connected to the receptacles. Typical reductions in performance are 2-4% for every 1000 ft (305 m) of elevation and 1% per 10°F (5.6°C) increase in ambient air temperature over 72°F (22°C).

WET STACKING

The unit is powered by a diesel engine. Diesel engines are susceptible to wet stacking if lightly loaded. Wet stacking occurs when an engine is run at less than 30% of its full load capacity, causing unburned fuel to accumulate in the exhaust system. Wet stacking can be detected by continuous black exhaust when the unit is under a constant load. It can also cause fouling of injectors and buildup on engine valves. Diesel engines operate properly when applied loads are between 30% and 100% capacity. Appropriate generator sizing is determined by the anticipated load. If the unit is in a wet stack condition, load the unit heavily for five hours or until the exhaust is clear.

RECEPTACLE PANEL

The receptacle panel is equipped with six receptacles for running accessories or tools from the generator. Power is supplied to the receptacles any time the engine is running and the main circuit breaker is switched to the ON (I) position. Each receptacle has an individual circuit breaker, located inside the cabinet under a flip-up cover. Each circuit breaker corresponds with each receptacle located below it on the receptacle panel.

Should the main breaker, or any of the individual circuit breakers trip, remove some of the load to the receptacles before turning them back on.

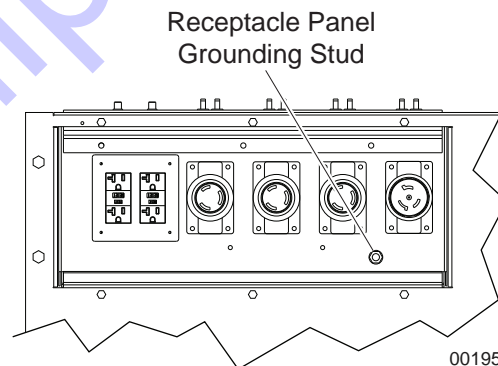

With all of the lights off, the full generator output may be used with the receptacles.

Note: To ensure proper grounding, anytime the generator is providing power to any equipment or load panels that do not have a grounded plug, a ground wire **MUST BE** added between the equipment and the grounding stud on the receptacle panel per the National Electrical Code (NEC), state and local regulations.

SHUTTING DOWN THE UNIT

Check with personnel using power supplied by the unit and let them know the power is going to be turned off. Make sure the power shut down will not create any hazards by accidentally turning off equipment that needs to be kept on (pumps, compressors, lights, etc.).

When you have finished using the unit, proceed with shut down as follows:

1. Remove any loads from the receptacles.
2. Switch the individual circuit breakers for each light to the OFF (O) position.
3. Switch the main circuit breaker to the OFF (O) position.

- Turn the Control Power switch to the OFF (O) position.

CIRCUIT BREAKERS

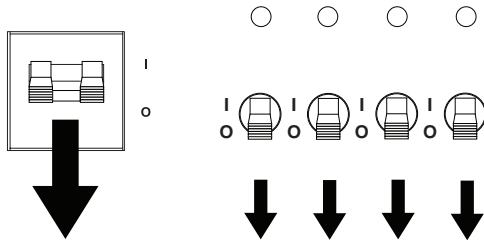

CONTROL POWER SWITCH

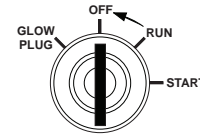

00925

Note: For extended storage time, disconnect the battery. For extended storage requirements, refer to the engine operator's manual.

USING THE WATER SUPPLY

⚠ CAUTION

NEVER use water in the supply tank for human consumption, even if the water is potable. The tank is made to store water for washing or domestic purposes only, drinking water from the tank could result in immediate or long term harm.

The unit comes equipped with a 500 gallon (1,895 L) water tank and a manifold with four hose bibbs. This allows the water tank to be connected to a trailer or RV for water to be used in non-potable applications. Two bibbs are for gravity feed only and two bibbs are pressurized by the onboard pump; the pump only operates when the engine is running.

TO USE THE PRESSURIZED WATER SUPPLY BIBB(S):

- Connect a hose from one of the pressure hose bibbs to the end location (trailer, RV, etc.).
- Start the engine.
- Switch the main circuit breaker to the ON (I) position.
- Open the pressure hose bibb(s).
- Switch the pump on; it will stop automatically when the water pressure reaches 35 psi (241 kPa).

TO USE THE GRAVITY WATER SUPPLY BIBB(S):

- Connect a hose from one of the gravity hose bibbs to the end location.
- Open the gravity hose bibb(s).

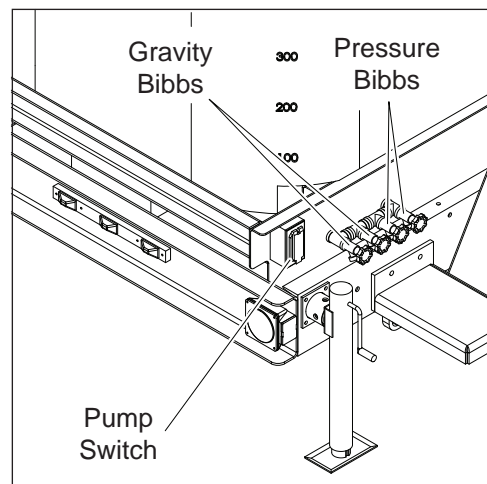

00229

NOTICE

Drain the tank when the temperature is expected to drop below 32°F (0°C) or if the unit is to be stored for a long period of time.

TO REFILL THE WATER TANK:

- Close all hose bibbs.
- Remove the tank cover; leave the smaller inspection cap in the center of the cover in place.

3. Fill the tank from a water source.

LOWERING THE MAST - MANUAL

1. Shut down the lights and engine, refer to *“Shutting Down the Unit” on page 22*. Allow the lights to cool 10-15 minutes before lowering the mast.
2. If the unit is going to be moved, it is recommended that the mast is turned so the lights face the rear of the unit. To rotate the mast:
 - A. Loosen the mast rotation knob.
 - B. Rotate the mast until the white arrows are aligned and the metal stop tabs are touching.
 - C. Tighten the mast rotation knob.

Note: For transportation, Magnum Power Products LLC strongly recommends the lights be removed from the mast and stowed. Refer to *“Removing the Lights for Transportation” on page 25*.

3. Turn the upper mast winch handle counterclockwise to collapse the mast to its lowest position. Ensure the electrical cord does not get caught in, or pinched by, the mast while it is being lowered.

▲ CAUTION

STOP IMMEDIATELY if the mast hangs up or the winch cable begins to develop slack. Excess slack in the cable could cause the mast to collapse, which could result in personal injury or equipment damage. Contact an authorized service center.

4. Release the mast lock by pulling the safety pin on the mast lock and pulling the lock bar free. Turn the handle of the lower mast winch counterclockwise until the mast rests in the transport cradle.

Note: If the mast lock bar does not pull free, activate the lower winch slightly to relieve pressure on the mast bar.

5. After the mast is completely down, insert the mast cradle locking pin and secure it with the safety pin.

LOWERING THE MAST - ELECTRIC WINCH OPTION

1. Shut down the lights and engine, refer to *“Shutting Down the Unit” on page 22*. Allow the lights to cool 10-15 minutes before lowering the mast.
2. If the unit is going to be moved, it is recommended that the mast is turned so the lights face the rear of the unit. To rotate the mast:
 - A. Loosen the mast rotation knob.
 - B. Rotate the mast until the white arrows are aligned and the metal stop tabs are touching.
 - C. Tighten the mast rotation knob.

Note: For transportation, Magnum Power Products LLC strongly recommends the lights be removed from the mast and stowed. Refer to *“Removing the Lights for Transportation” on page 25*.

3. Press and hold the upper winch control switch downward to collapse the mast to its lowest position. Ensure the electrical cord does not get caught in, or pinched by, the mast while it is being lowered.

Note: Some electric winch models are equipped with an anti-backlash safety limit switch. This switch will disconnect power to the winch if excess cable slack is detected, preventing accidental lowering of the mast.

▲ CAUTION

STOP IMMEDIATELY if the mast hangs up or the winch cable begins to develop slack. Excess slack in the cable could cause the mast to collapse, which could result in personal injury or equipment damage. Contact an authorized service center.

4. Release the mast lock by pulling the safety pin on the mast lock and pulling the lock bar free. Lower the mast by holding the lower winch control switch downward until the mast is resting in the transport cradle.

Note: If the mast lock bar does not pull free, activate the lower winch slightly to relieve pressure on the mast bar.

5. After the mast is completely down, insert the mast cradle locking pin and secure it with the safety pin.

REMOVING THE LIGHTS FOR TRANSPORTATION

1. On units equipped with quick disconnect fittings for the lights, disconnect the power cords from the junction box at the top of the mast. Replace the dust caps on the junction box. On hard wired units, remove the junction box cover, located on the top of the mast, and disconnect **ONLY** the mast light wires from the connectors. To release the mast light wires from the connectors, flip the locking levers down and pull out the appropriate wires.
2. Remove the lights by removing the wing nut that holds the light fixture bracket to the cross tube. Attach the lights to the storage brackets (if equipped) located on the mast tube on either side of the central lift point.

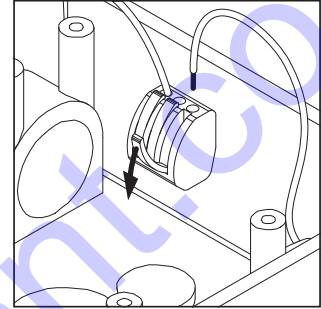

00232

TOWING THE UNIT

Once the engine is shut down and the mast and lights are properly stowed, follow these steps to prepare the unit for towing.

1. Raise the four leveling jacks completely and remove the locking pins to rotate them up into the travel position. Replace the locking pins.
2. Use the tongue jack to raise or lower the trailer onto the hitch of the towing vehicle. Lock the hitch coupling and attach the safety chains or cables to the vehicle. Raise the tongue jack completely.

Note: A film of grease on the coupler will extend coupler life and eliminate squeaking. Wipe the coupler clean and apply fresh grease each time the unit is towed.

3. To ensure proper operation of the jacks, lube the grease fittings located on the leveling jacks. Refer to “*Jack Maintenance*” on page 30. For maintenance interval information, refer to “*Basic Maintenance Schedule - Isuzu Engine*” on page 27.
4. Connect any trailer wiring to the tow vehicle. Check for proper operation of the directional and brake lights.
5. Make sure the mast cradle locking pin is in place.
6. Make sure the doors are properly latched.
7. If the unit is going to be driven over rough ground, remove the bulbs from the light fixtures. Refer to “*Removing the Lights for Transportation*” on page 25.
8. Check for proper inflation of the trailer tires. Refer to the Specification section beginning on page 10.
9. Check the wheel lugs. Tighten or replace any that are loose or missing. If a tire has been removed for axle service or replaced, tighten the lugs, in the order shown, to the following specifications:
 - A. Start all lug nuts by hand.
 - B. First pass tighten to 20-25 ft-lbs (27-33 Nm).
 - C. Second pass tighten to 50-60 ft-lbs (67-81 Nm).
 - D. Third pass tighten to 90-120 ft-lbs (122-162 Nm).

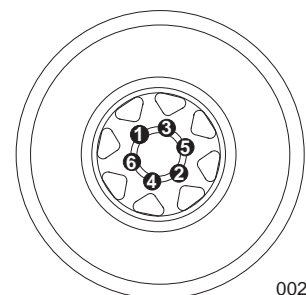

00205

Note: After the first road use, re-torque the lug nuts in sequence.

10. Maximum recommended speed for highway towing is 45 mph (72 km/h). Recommended off-road towing speed is not to exceed 10 mph (16 km/h) or less, depending on the terrain.

LIFTING THE UNIT

⚠ WARNING
THE WATER TANK MUST BE EMPTY BEFORE LIFTING THE UNIT. Only lift a combination unit using the lower forklift pockets, do not use the central lift point or mast mounted forklift pockets. Failure to comply may result in damage to equipment and/or serious personal injury.

1. Make sure the equipment being used to lift the unit has sufficient capacity. For approximate weights, refer to the Specification section beginning on [page 10](#).
2. Make sure the mast cradle locking pin is in place.
3. Always remain aware of people and objects around the unit while moving.
4. Use the lower forklift pockets with care. Approach the unit perpendicularly to avoid any damage to the unit. Make sure any obstructions are clear of the forklift tines before lifting.

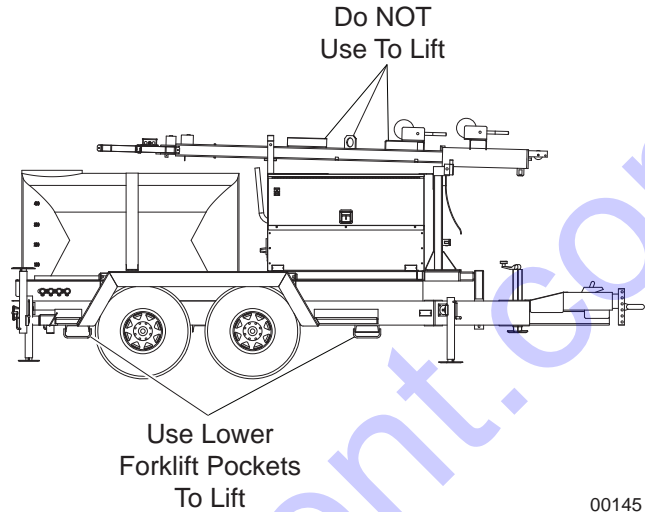

00145

GENERAL MAINTENANCE

Poorly maintained equipment can become a safety hazard. In order for the equipment to operate safely and properly over a long period of time, periodic maintenance and occasional repairs are necessary. **NEVER** perform routine service (oil/filter changes, cleaning, etc.) unless all electrical components are shut off. Before servicing the unit, always follow the instructions listed below.

- Ensure the Control Power switch is turned to the OFF (O) position.
- Ensure the circuit breakers are open, in the OFF (O) position.
- Activate (push in) the emergency stop switch.
- Disconnect the negative (-) terminal on the battery.
- Attach a "Do Not Start" sign to the control panel. This will notify everyone that the unit is being serviced and will reduce the chance of someone inadvertently trying to start the unit.
- Never wash the unit with a high pressure hose or with any kind of power washer.
- Never wash the engine block or fuel tank with a power washer or steam cleaner. Water may enter the cabinet and collect in the generator windings or other electrical parts, causing damage.
- If the unit is stored outside, check for water inside the cabinet and generator before each use. If wet, dry the unit thoroughly before starting.
- Inspect condition of electrical cords. **DO NOT** use the unit if insulation is cut or worn through.
- Check that winch cables are in good condition and are centered on each pulley. **DO NOT** use a cable that is kinked or starting to unravel.
- Check that the safety pins for the mast lock rod and mast lock bar are present and secured with a chain. Check that the spring located in the mast lock bar is not broken or missing. Check the operation of the mast lock bar.
- Check the wheel lugs. Refer to ["Towing the Unit" on page 25](#).
- Check coolant levels. Refer to the engine operator's manual when determining proper mixture.

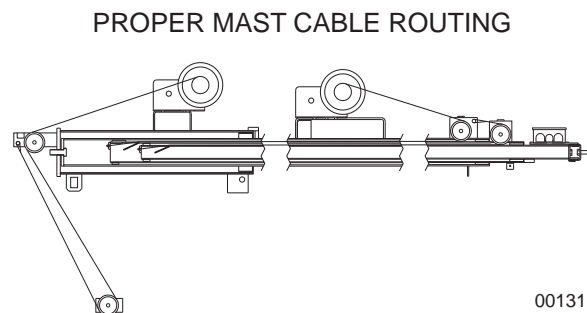

00131

- Coolant is checked visually by inspecting the level in the coolant overflow jug near the radiator.
- Normal operation is between the full and add markings on the overflow jug, this is known as normal range.
- **WHEN ENGINE IS STOPPED AND COMPLETELY COOL**, coolant may be added directly to the jug.
- Check the oil levels. Refer to the engine operator's manual when determining proper viscosity.
 - **DO NOT** start the unit if the engine oil level is below the add mark on the dipstick.
 - Normal operation is between the full and add markings on the dipstick.
 - Add oil only if oil level is below cross-hatch pattern on the dipstick. **DO NOT OVERFILL** crankcase.
- Check fuel level.

Note: If the engine was run out of fuel or the fuel tank was drained, it may be necessary to bleed the fuel lines. Refer to the engine operator's manual supplied with the unit.

BASIC MAINTENANCE SCHEDULE - ISUZU ENGINE

NOTICE

Refer to the original equipment manufacturer's operating manual for a complete list of maintenance requirements. Failure to comply with the procedures as described in the engine operator's manual will nullify the warranty, decrease performance and cause equipment damage or premature equipment failure. Maintenance records may be required to complete a warranty request.

Use the schedule in the following table as a guide for regular maintenance intervals. For additional or replacement copies of the engine operator's manual, contact an authorized dealer in your area.

Item	Daily	250 Hours	500 Hours	1000 Hours
Check Oil Level	◆			
Check Coolant Level	◆			
Check Fuel Level	◆			
Drain Fuel Filter	◆			
Check Tire Pressure	◆			
Check All Electrical Connections	◆			
Clean Battery	◆			
Check Fan Belt Tension (Replace If Necessary)	◆			
Inspect Radiator Fins For Debris, Clean As Required	◆			
Preheating Condition Check	◆			
Check Engine Starting Conditions And Noise Conditions	◆			
Check Exhaust Smoke Condition	◆			
Inspect Light Tower Winch For Proper Operation	◆			
Replace Engine Oil		◆		
Replace Fuel Filter Element		◆		
Clean Water Sedimenter Element		◆		
Electromagnetic Pump Filter Replacement Or Cleaning		◆		
Check Fan Belt Tension (Replace If Necessary)			◆	
Oil Filter Element Replacement			◆	
Replace Air Filter Element			◆	
Lubricate Leveling Jacks			◆	
Replace Heated Fuel Filter (If Equipped)				◆
Inspect Engine Starting Battery				◆

BASIC MAINTENANCE SCHEDULE - MITSUBISHI ENGINE

NOTICE

Refer to the original equipment manufacturer's operating manual for a complete list of maintenance requirements. Failure to comply with the procedures as described in the engine operator's manual will nullify the warranty, decrease performance and cause equipment damage or premature equipment failure. Maintenance records may be required to complete a warranty request.

Use the schedule in the following table as a guide for regular maintenance intervals. For additional or replacement copies of the engine operator's manual, contact an authorized dealer in your area.

Item	Daily	50 Hours	250 Hours	400 Hours	500 Hours	1000 Hours	As Required
Check Oil Level	◆						
Check Coolant Level	◆						
Check Fuel Level	◆						
Check Tire Pressure	◆						
Check All Electrical Connections	◆						
Inspect Radiator Fins For Debris, Clean As Required	◆						
Inspect Light Tower Winch For Proper Operation	◆						
Fuel Tank - Drain Water		◆					
Check Air Cleaner		◆					
Replace Engine Oil And Oil Filter			◆*				
Belt And Belt Tension - Inspect And Adjust			◆				
Replace Fuel Filter				◆			
Drain And Clean Fuel Tank					◆**		
Check Glow Plugs					◆		
Lubricate Leveling Jacks					◆		
Bolts And Nuts On The Engine - Retighten						◆*	
Replace Heated Fuel Filter (If Equipped)						◆	
Inspect Engine Starting Battery						◆	
Air Cleaner Element - Clean, Check And Replace							◆
Fuel System - Bleed Air							◆
Water Sedimenter - Drain Water							◆

* Perform after the initial 50 hours of operation, then on the regularly scheduled interval indicated in the schedule above.

** Certain conditions may require the fuel tank to be drained and cleaned more often. When operating in extremely dusty conditions, clean the fuel tank as often as necessary.

WINCH USE, OPERATION & MAINTENANCE - MANUAL

PRIOR TO USE

- Inspect rope or cable and replace if damaged.
- Check mounting hardware for proper tightness and re-torque if necessary.
- Gears, ratchet pivot point and shaft bushings must be kept lubricated with a thin oil or grease.

OPERATION

Take Line/Load In:

1. The cable must be securely fastened to the object being lifted and to the winch drum.

2. Always be sure that the cable and cable attachments are not damaged and are strong enough for the load. Ensure there is an adequate safety factor of at least three times the maximum load for all components used.
3. Referring to the Cable In/Cable Out decal on the winch, turn handle according to the specified direction to lift. The ratchet **MUST** make a loud clicking sound while pulling line in.

Let Line/Load Out:

1. Referring to the Cable In/Cable Out decal on the winch, turn handle according to the specified direction to lower. No clicking will be heard because the brake system is activated.

MAINTENANCE

The following procedures should be performed at least annually:

1. The gears and bushings of the winch must be kept lubricated. Apply a thin film of grease to the gear teeth, and oil the bushings as needed.
2. The ratchet pawl pivot point must be kept lubricated with a thin oil.
3. Do not get oil or grease on the friction discs.

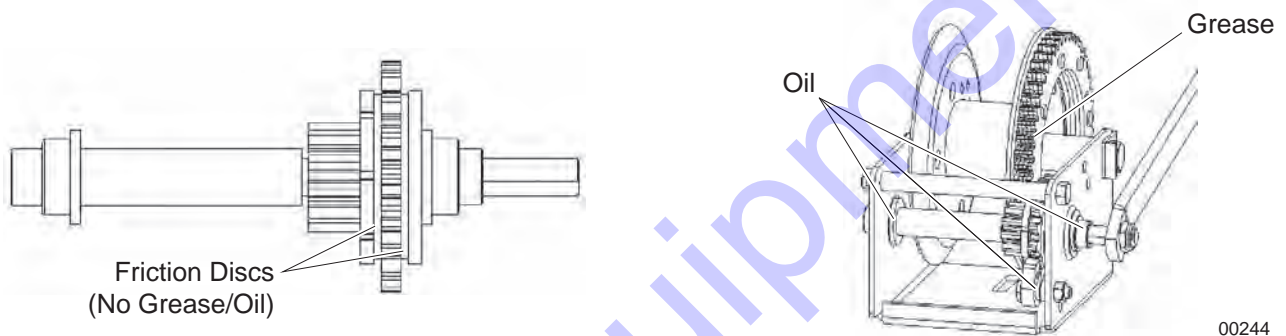

WINCH USE, OPERATION & MAINTENANCE - ELECTRIC

- Keep winch free of dirt, oil, grease, water and other substances.
- Check all mounting bolts and make sure they are tightened to the recommended torque values. Replace any damaged fasteners.
- Periodically check all connections to be sure they are tight and free of corrosion.
- Check cable for visible damage every time the winch is operated. Examples of damage are: cuts, knots, mashed or frayed portions, and broken strands. Replace cable immediately if damaged. Failure to replace a damaged cable could result in breakage.
- Regularly check brake for slippage or drift. This is detected visually when winch is under load. If winch drum continues to turn after controls are released, the brake may need to be replaced.
- Periodically clean and grease brake assembly. This will ensure proper performance and extend the life of the winch. If winch seems to labor or get excessively hot during the lowering of loads, the brake will need to be serviced or replaced.
- Check motor brushes periodically and replace when necessary.

Note: Only the motor brushes and brake assembly require periodic replacement.

PREVENTIVE MAINTENANCE SCHEDULE

Maintenance Activity	After First Operation	Before Each Use	Semi-Annually Or After Each 25 Hours Of Operation
Check Fasteners	◆		◆
Check Electrical Connections	◆		◆
Clean And Grease Brake Assembly			◆

Check Motor Brushes			◆
Visually Check Winch And Control	◆	◆	◆

MECHANICAL BRAKE

The mechanical brake generates heat when loads are lowered and the wire cable is powered out. Care must be taken to avoid overheating the mechanical brake.

Whine or chatter associated with a new mechanical brake is normal and typically disappears with use.

Overheating the mechanical brake may result in permanent damage to, or failure of, the brake. Replace any damaged brake components before resuming use of the winch.

JACK MAINTENANCE

The following procedures should be performed at least annually.

SIDE-WIND MODELS

- The internal gearing and bushings of the jack must be kept lubricated. Apply a small amount of automotive grease to the internal gearing by removing the jack cover, or if equipped, use a needle nose applicator or standard grease gun on the lubrication point found on the side of the jack near the crank. Rotate the jack handle to distribute the grease evenly.
- A lightweight oil must be applied to the handle unit at both sides of the tube.
- If equipped, the axle bolt and nut assembly of the caster wheel must also be lubricated with the same lightweight oil.

TOP-WIND MODELS

- Apply a lightweight oil to the screw stem.

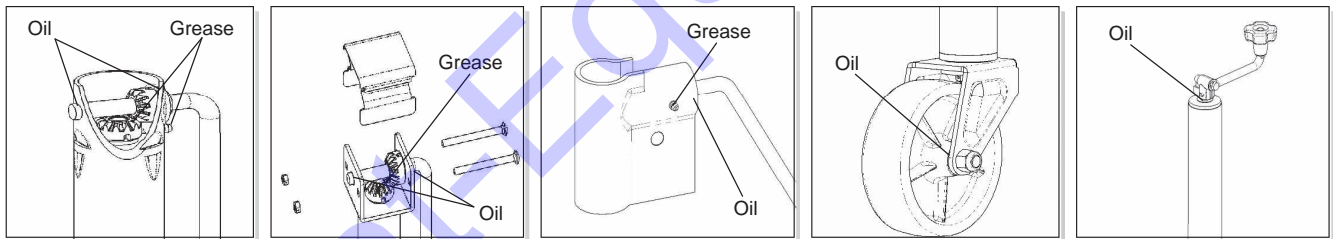

00243

TRAILER WHEEL BEARINGS

The trailer axles are equipped with a grease zerk fitting to allow lubrication of the wheel bearings without the need to disassemble the axle hub. To lubricate the axle bearings, remove the small rubber plug on the grease cap, attach a standard grease gun fitting to the grease zerk fitting and pump grease into the fitting until new grease is visible around the nozzle of the grease gun. Use only a high quality grease made specifically for lubrication of wheel bearings. Wipe any excess grease from the hub with a clean cloth and replace the rubber plug when finished. The minimum recommended lubrication is every 12 months or 12,000 miles (19,312 km). More frequent lubrication may be required under extremely dusty or damp operating conditions.

LOWER RADIATOR HOSE HEATER OPTION - USE AND MAINTENANCE

⚠ CAUTION

Improper use of the lower radiator hose heater could result in damage to the engine or personal injury. Do not modify the location of the lower radiator hose heater.

The following points should be followed when operating a unit equipped with a lower radiator hose heater.

- Ensure the cooling system is full of the proper mixture of water and engine coolant before each heater use.
- The heater is designed for all-night operation, however, 2-5 hours of heating just prior to starting is usually sufficient for proper engine starting.
- The unit must be level to maintain proper orientation of the heater while it is in operation.
- Use only an undamaged, outdoor rated, three-prong grounded 120VAC extension cord with a minimum amperage rating of 10A. Connect the cord to a properly grounded 120VAC, GFCI receptacle.
- Before starting the engine, unplug the extension cord from the power first, then unplug the heater cordset from the extension cord.

TROUBLESHOOTING THE LIGHTS

⚠ DANGER

THIS UNIT USES HIGH VOLTAGE CIRCUITS CAPABLE OF CAUSING SERIOUS INJURY OR DEATH. ONLY A QUALIFIED ELECTRICIAN SHOULD TROUBLESHOOT OR REPAIR ELECTRICAL PROBLEMS OCCURRING IN THIS EQUIPMENT.

MAST LIGHTS OFF BUT BALLAST INDICATORS ON CONTROL PANEL ARE ON

1. Mast light is too hot. Allow light to cool 10-15 minutes before restarting.
2. Faulty bulb connection. Check that the bulb is tight in the socket.
3. Bulb broken. Check for broken arc tube or outer bulb jacket, broken or loose components in bulb envelope or blackening/deposits inside tube.
4. Check the connections inside the mast junction box and each mast light housing/socket.
5. Check the mast electrical cord for damage and check the cord connections inside the control box.

MAST LIGHTS OFF AND BALLAST INDICATORS ON CONTROL PANEL ARE OFF

1. Check the connections inside the control box and inside each ballast box.
2. Generator output incorrect. Check the incoming voltage to the ballast by checking the available voltage on the GFCI receptacle. Incoming voltage should be 120V +/- 5V. If voltage is incorrect, the engine speed may need to be adjusted or generator may require service.
3. Low transformer output. The voltage from the transformer should read approximately 400VAC as the light "strikes" (induces an arc), then drop and slowly rise back up to stabilize at 240-260VAC. On quick disconnect models, measure across the junction box terminals when the light is unplugged. On hard wired models, remove the mast junction box cover and insert the wire probes into the connector blocks for the light and ground. If proper voltage is not achieved, perform capacitor check to determine if the capacitor or coil needs to be replaced.

MAST LIGHTS ON BUT THE LIGHT OUTPUT IS LOW

1. Fixture and/or lens is dirty. Clean reflective surface inside fixture and both inside and outside surface of glass lens. Use mild soap and water to clean lens. Other chemicals may have an adverse effect on the glass.
2. Bulb worn due to normal use. Replace bulb.
3. Check the mast coil cord, mast junction box and mast light connections.
4. Generator output incorrect. Check the incoming voltage to the ballast. Incoming voltage should be 120V +/- 5V. If the voltage is incorrect, the engine speed may need to be adjusted or the generator may require service.
5. Low transformer output. The voltage from the transformer should read approximately 400VAC as the light "strikes" (induces an arc), then drop and slowly rise back up to stabilize at 240-260VAC. On quick

disconnect models, measure across the junction box terminals when the light is unplugged. On hard wired models, remove the mast junction box cover and insert the wire probes into the connector blocks for the light and ground. If proper voltage is not achieved, perform capacitor check to determine if the capacitor or coil needs to be replaced.

TROUBLESHOOTING AUTOMATIC SHUTDOWN CONDITIONS

▲ WARNING

Allow engine to cool before performing any troubleshooting procedures. Contacting the engine when it is hot will cause personal injury.

LOW OIL PRESSURE SHUTDOWN

1. Check the level of the engine oil with the dipstick. The engine controller will shut the engine down when the oil pressure is less than 20 psi (138 kPa). Add oil if required.
2. Visually inspect the engine for oil leaks.
3. If the oil level is good, restart the unit and verify the loss of oil pressure. Shut the engine down immediately if the oil pressure value does not read 5 psi (34 kPa) within five seconds.
4. Check the oil pressure sender. To identify corrective action, refer to the troubleshooting section of the engine operator's manual provided with the unit.

HIGH COOLANT TEMPERATURE SHUTDOWN

1. Check the coolant level in the overflow jug.
2. Restart the engine and read the coolant temperature to verify a high coolant temperature shutdown. Stop the engine immediately if the coolant temperature is 230°F (110°C) or more.
3. **ALLOW THE ENGINE TO COOL.** Add coolant to the overflow jug if it is low and then check the level of coolant in the radiator. To access the radiator cap, you must remove the access panel from the top of the enclosure directly above the radiator. Add coolant until it is 3/4 in. (1.9 cm) below the filler neck. Secure the radiator cap back and access panel into their original position.
4. Check the radiator shroud and ducting for blockage and remove any foreign matter.
5. Inspect coolant hoses, engine block and water pump for visible leaks.
6. Check the tension of the serpentine drive belt for the water pump.
7. If no other problems are found, remove the load on the generator and restart the engine. Check the coolant temperature and shut the engine down immediately if it starts to overheat. For additional information on engine overheating, refer to the engine operator's manual.

OVERCRANK SHUTDOWN

1. Check the fuel level in the tank.
2. Check for proper operation of the fuel pump.
3. Check the air filter for blockage.
4. If the engine will not start, refer to the engine operator's manual for additional information on troubleshooting starting problems.

OVERSPEED OR UNDERSPEED SHUTDOWN

1. Disconnect all loads and restart the unit. Read the frequency (Hz) on the LCD display. With no loads on the generator, the frequency should read 60.0 Hz.
2. If the frequency is above or below 60.0 Hz, the engine speed will have to be adjusted. Refer to the engine operator's manual for throttle adjustments on mechanical governed units and see the electronic governor manual for electronically controlled units.

MAST LIGHT CONNECTIONS

MAST JUNCTION BOX WIRING 4-LIGHT

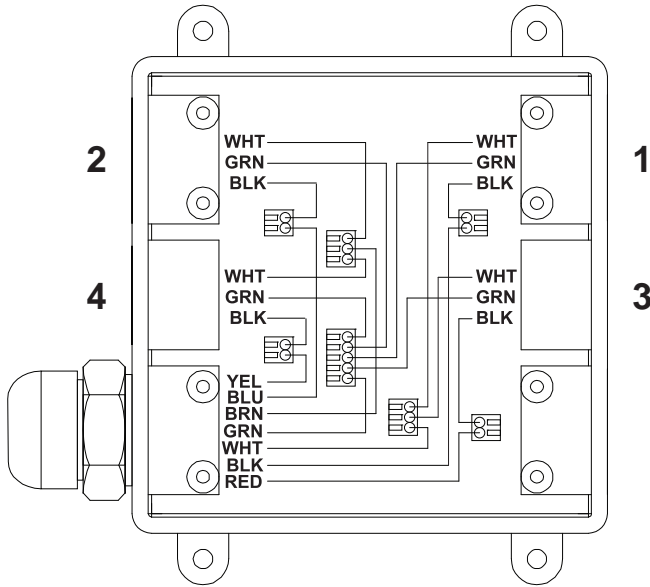

MAST LIGHT CONNECTIONS 4-LIGHT

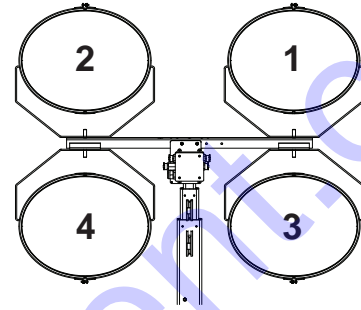

00175

Discount-Equipment.com

AC WIRING DIAGRAM - MTT15

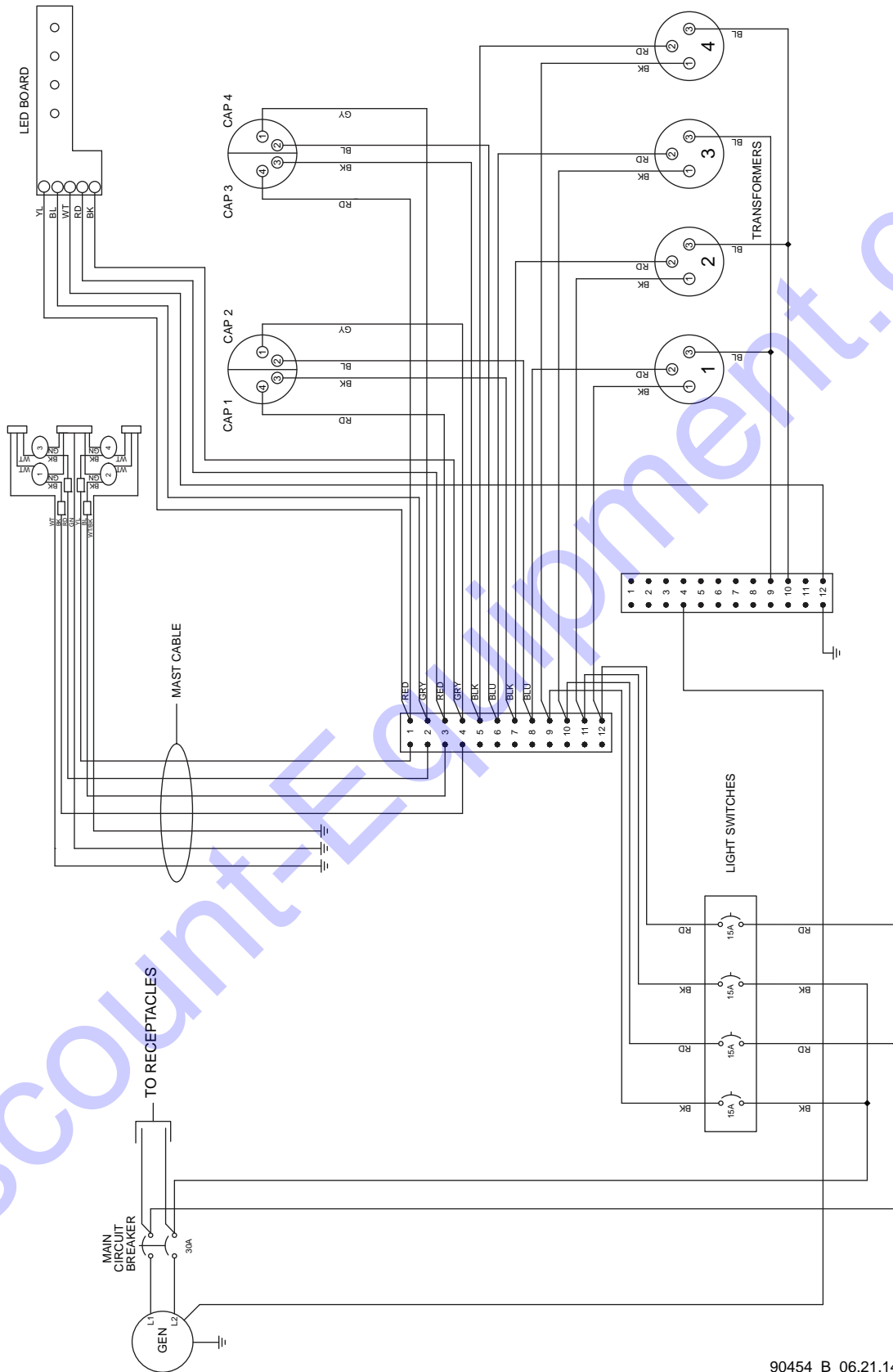

90454_B_06.21.14

AC WIRING DIAGRAM - MTT20, MTT20CAN

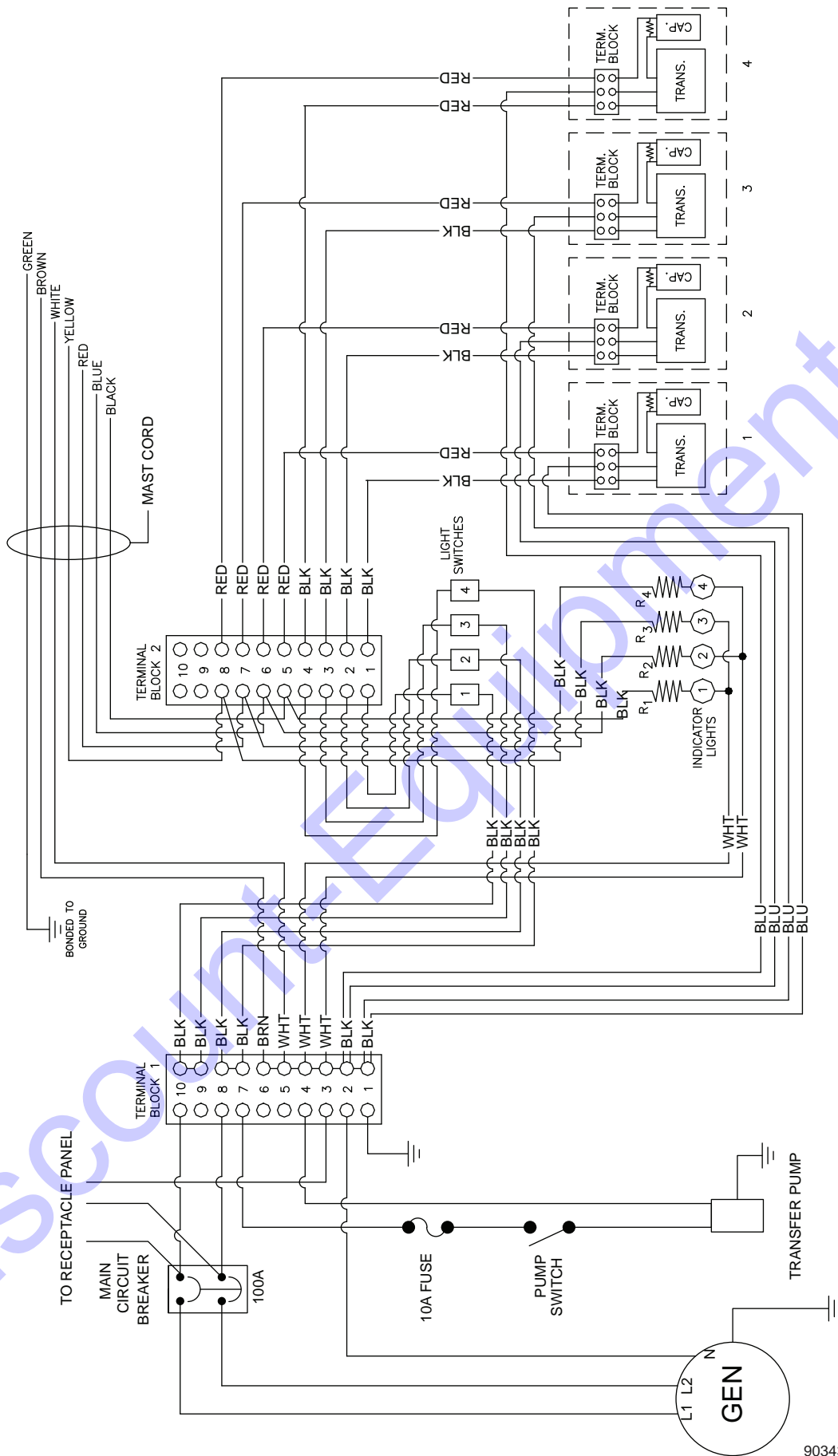

90343_ORG_12.14.11

AC WIRING DIAGRAM - RECEPTACLE PANEL

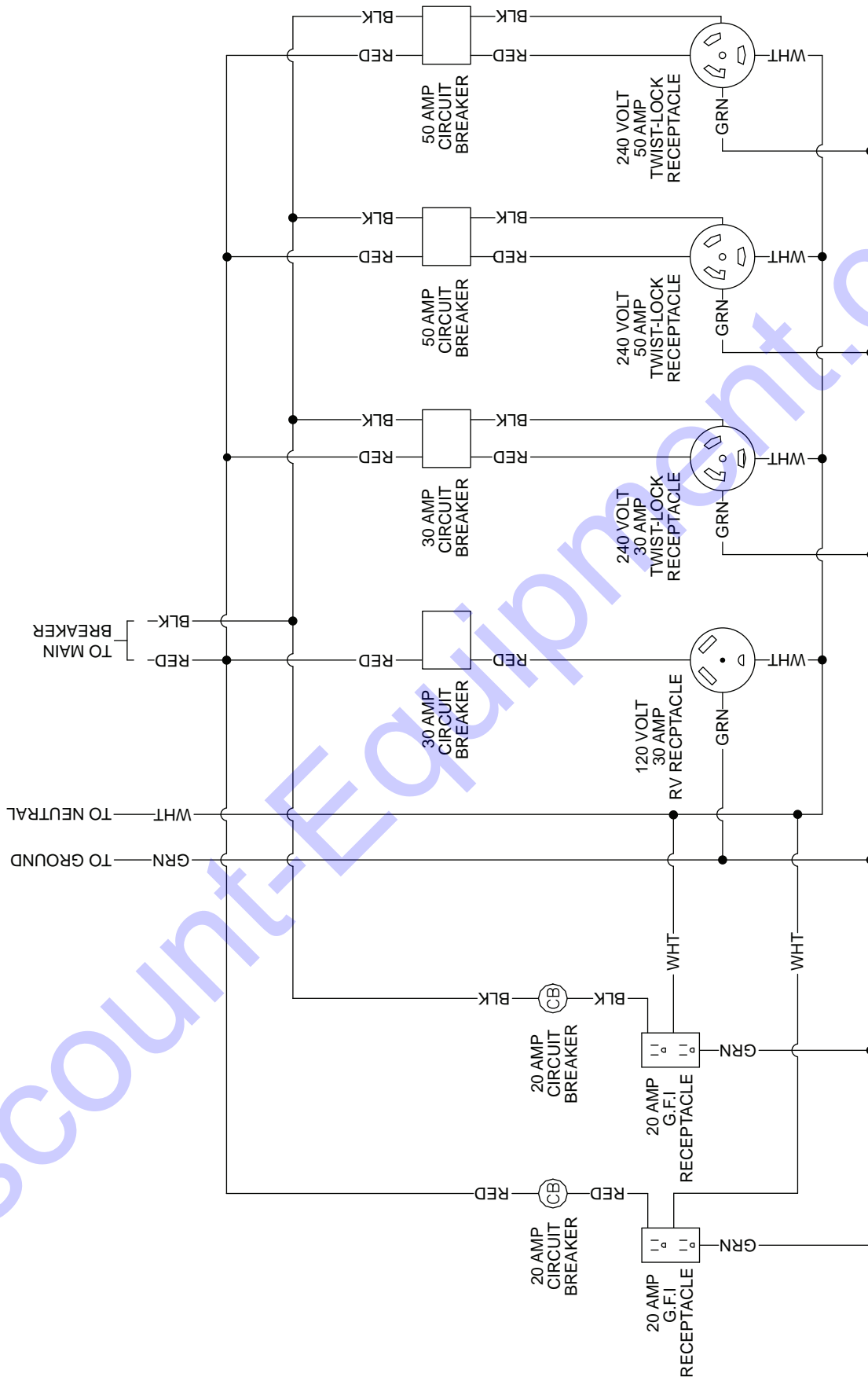

(2x5-20R, 1xTT-30, 1xL14-30R, 2x14-50)

90317_ORG_07.06.11

AC WIRING DIAGRAM - RECEPTACLE PANEL OPTIONS (1 OF 2)

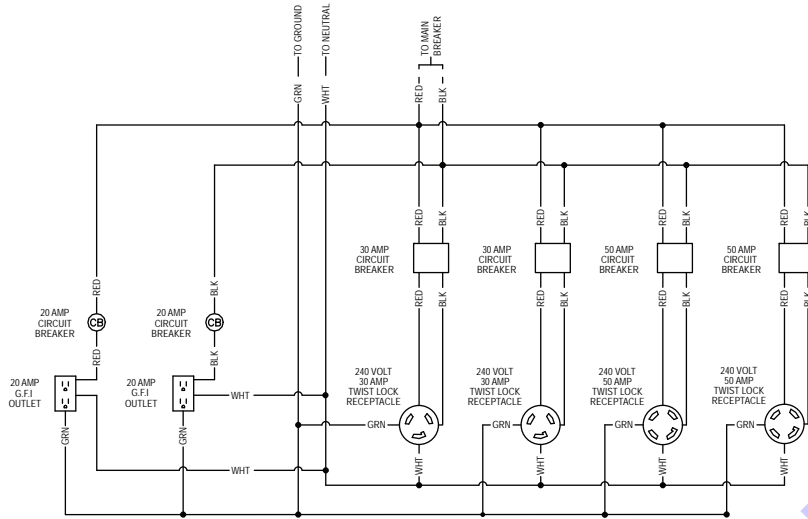

Receptacle Panel (2x5-20R, 2xL6-30R, 2xL14-50)

90315_ORG_10.14.11

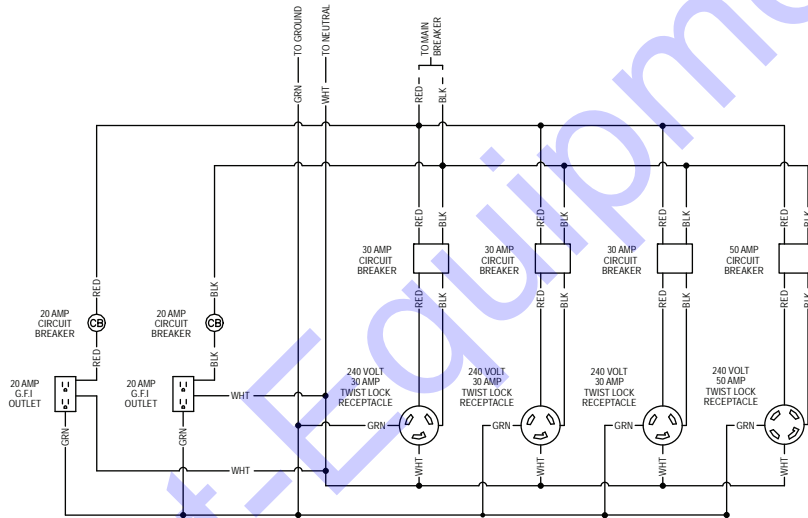

Receptacle Panel (2x5-20R, 3xL6-30R, 1xL14-50)

90318_ORG_07.06.11

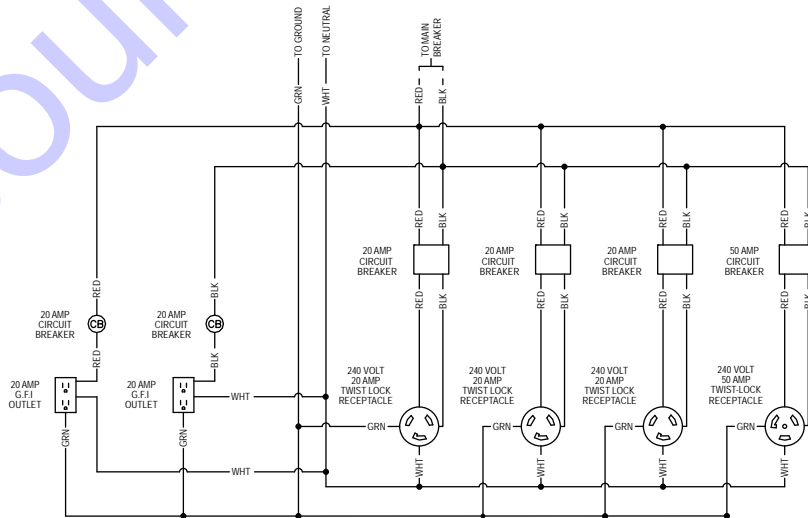

Receptacle Panel (2x5-20R, 3xL6-20R, 1x50A)

90319_ORG_07.06.11

AC WIRING DIAGRAM - RECEPTACLE PANEL OPTIONS (2 OF 2)

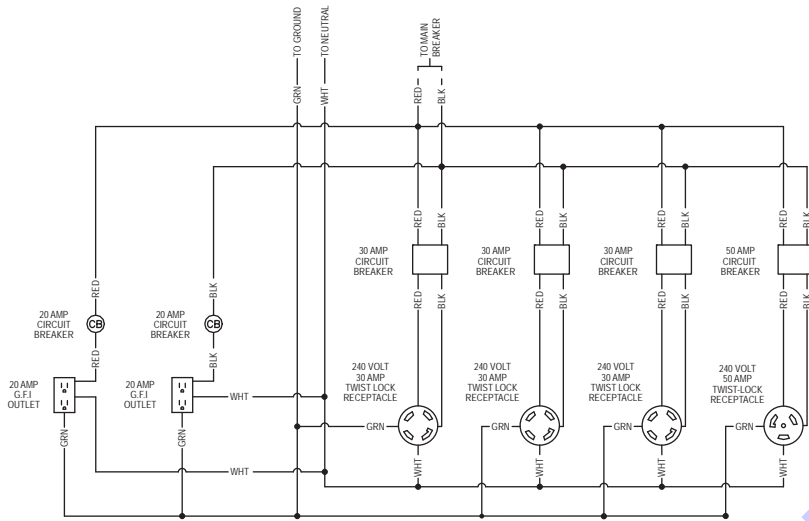

Receptacle Panel (2x5-20R, 3x14-30R, 1x50A)

90320_ORG_07.06.11

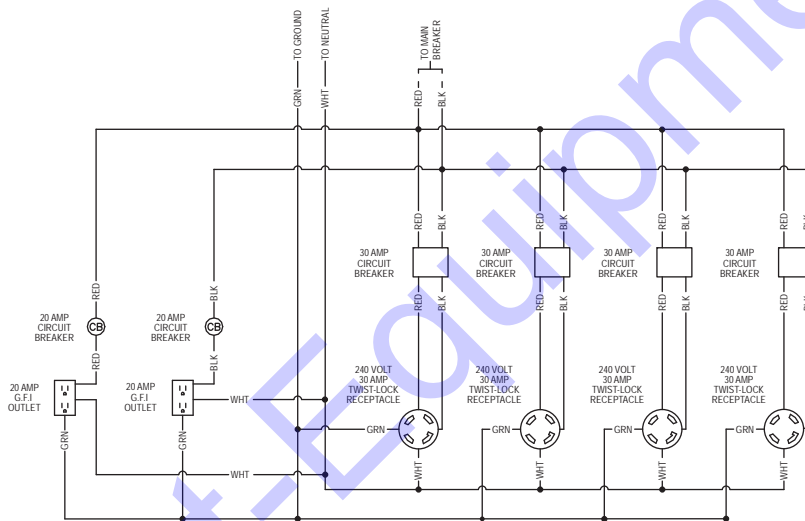

Receptacle Panel (2x5-20R, 4x14-30R)

90321_ORG_07.06.11

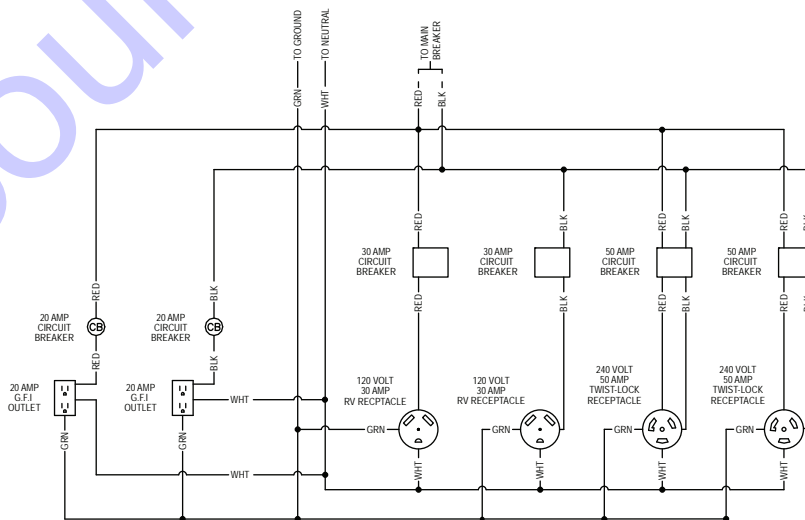

Receptacle Panel (2x5-20R, 2xTT-30, 2x14-50)

90355_ORG_07.06.11

DC WIRING DIAGRAM - MTT15

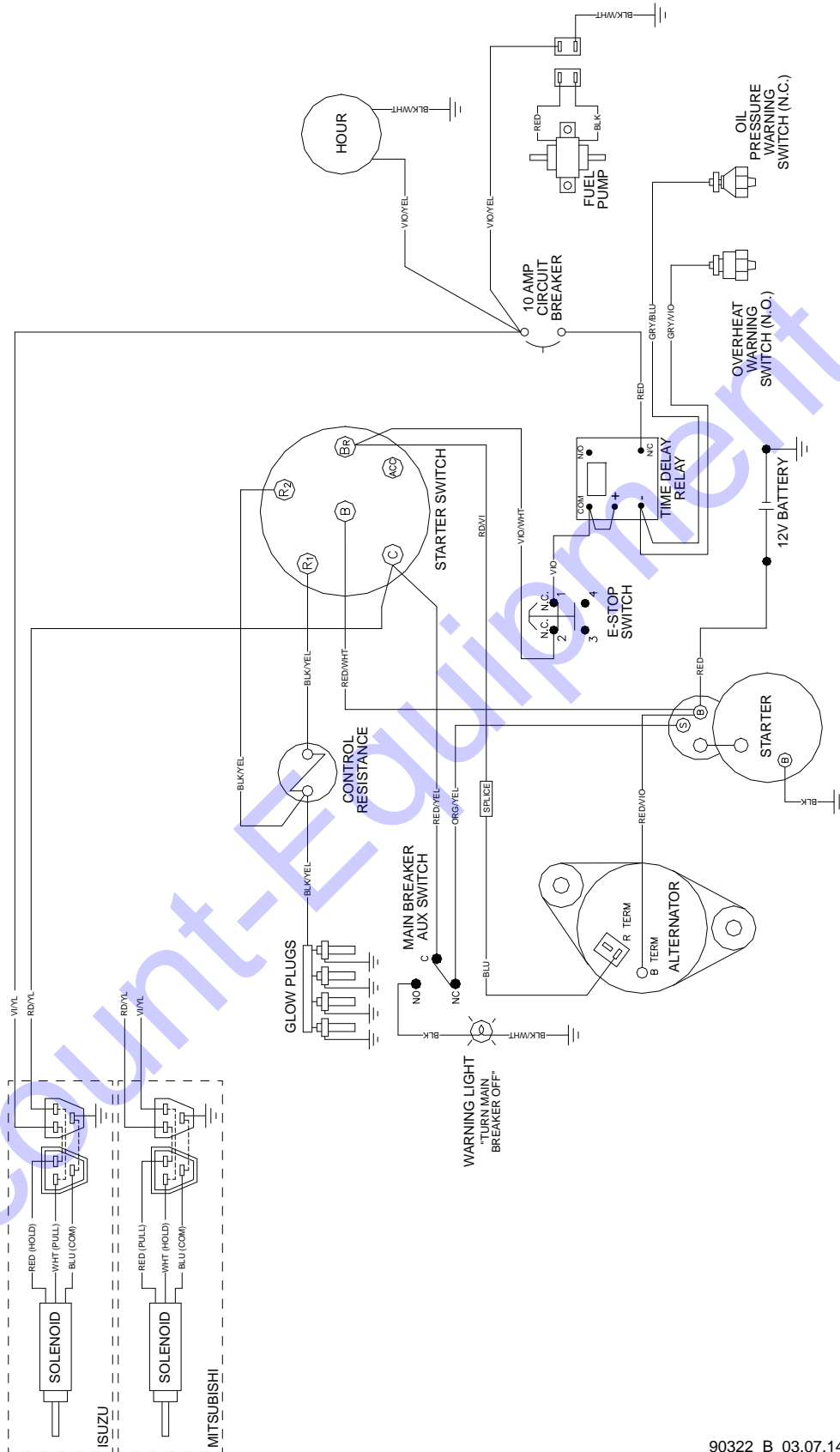

90322_B_03.07.14

DC WIRING DIAGRAM - ELECTRIC WINCH FOR MTT15

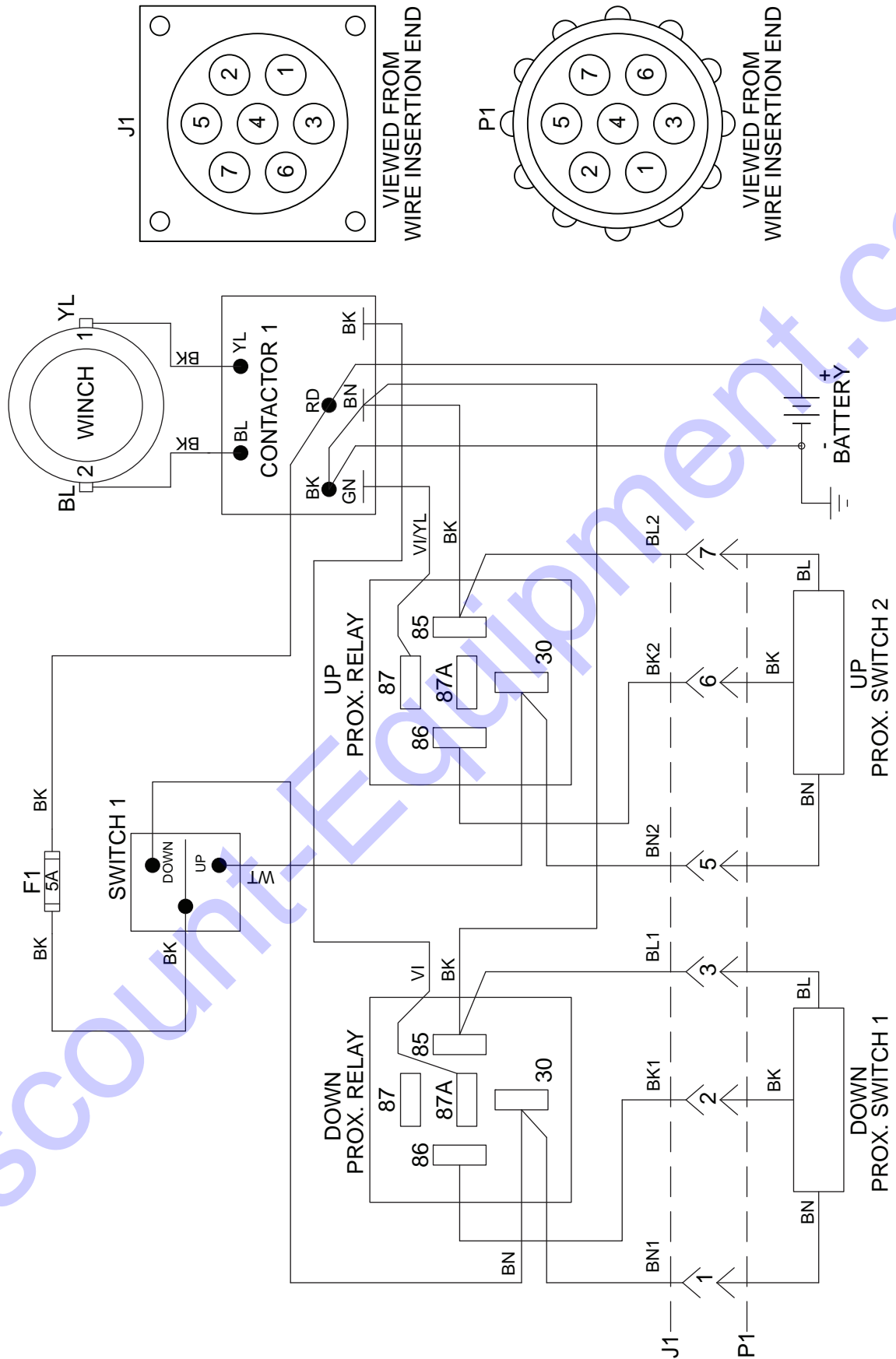

90443_H_06.10.14

DC WIRING DIAGRAM - ELECTRIC WINCH FOR MTT20, MTT20CAN

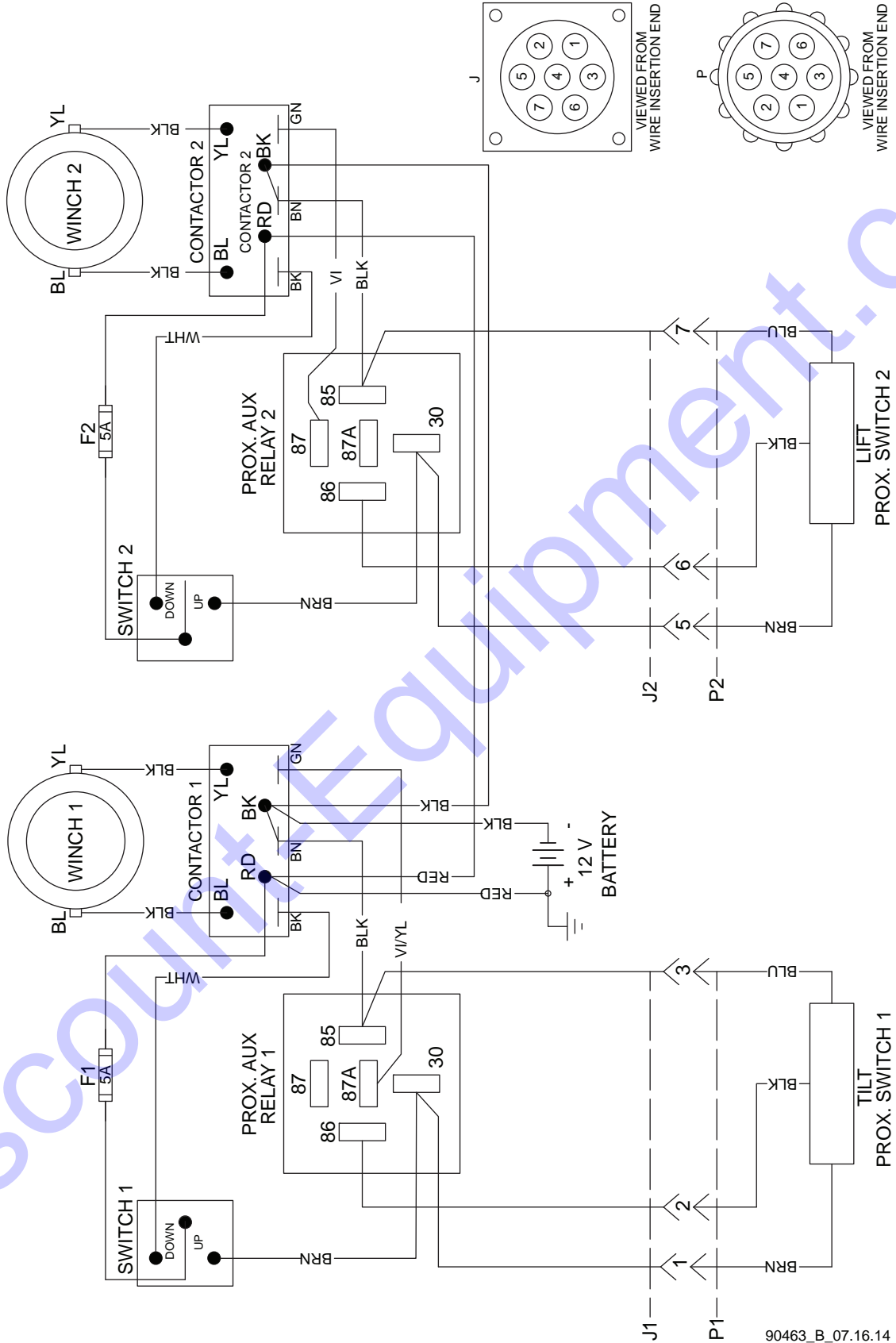

90463_B_07.16.14

DC WIRING DIAGRAMS FOR OPTIONS EQUIPMENT

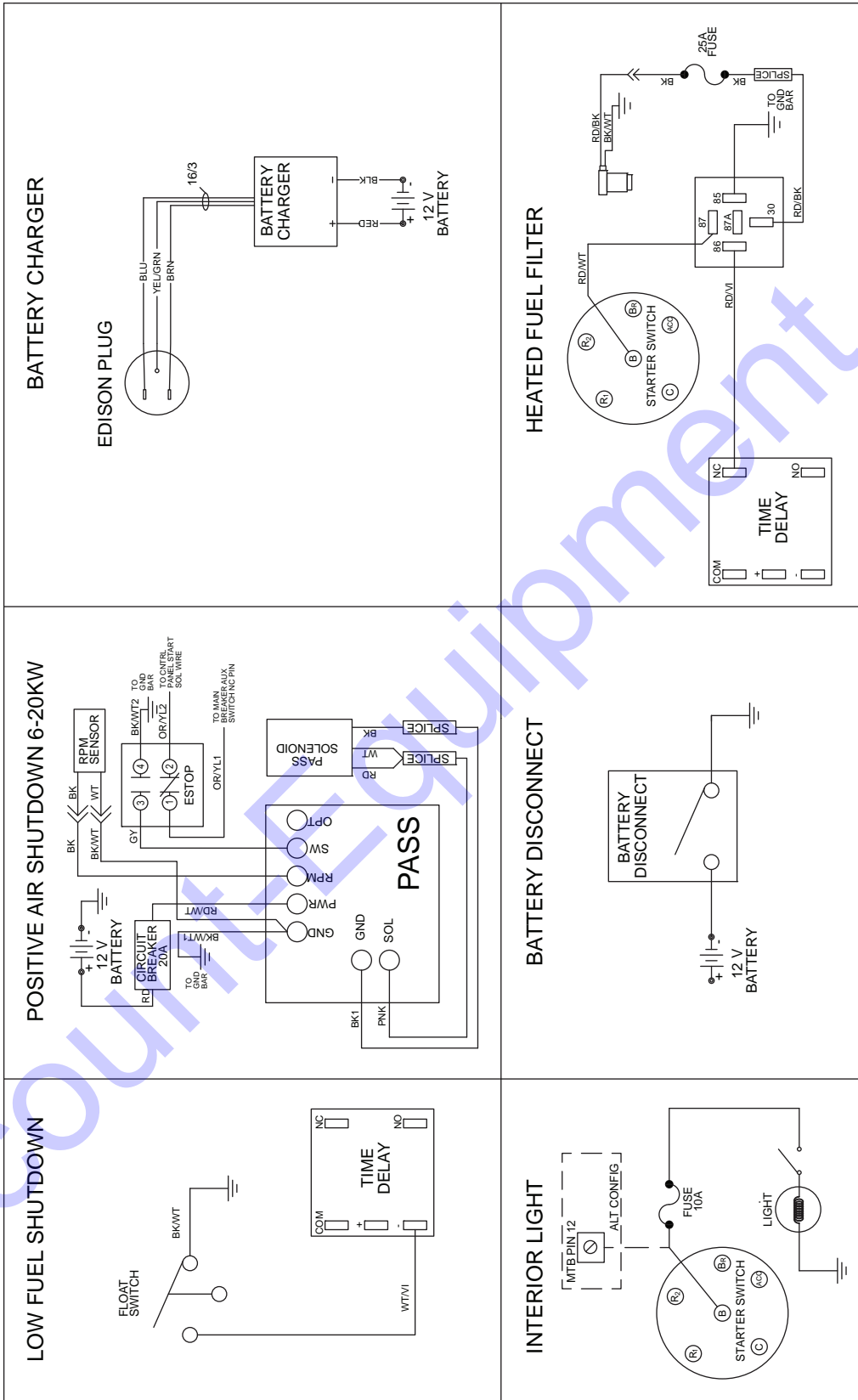

TRAILER LIGHTS WIRING DIAGRAM - MTT15

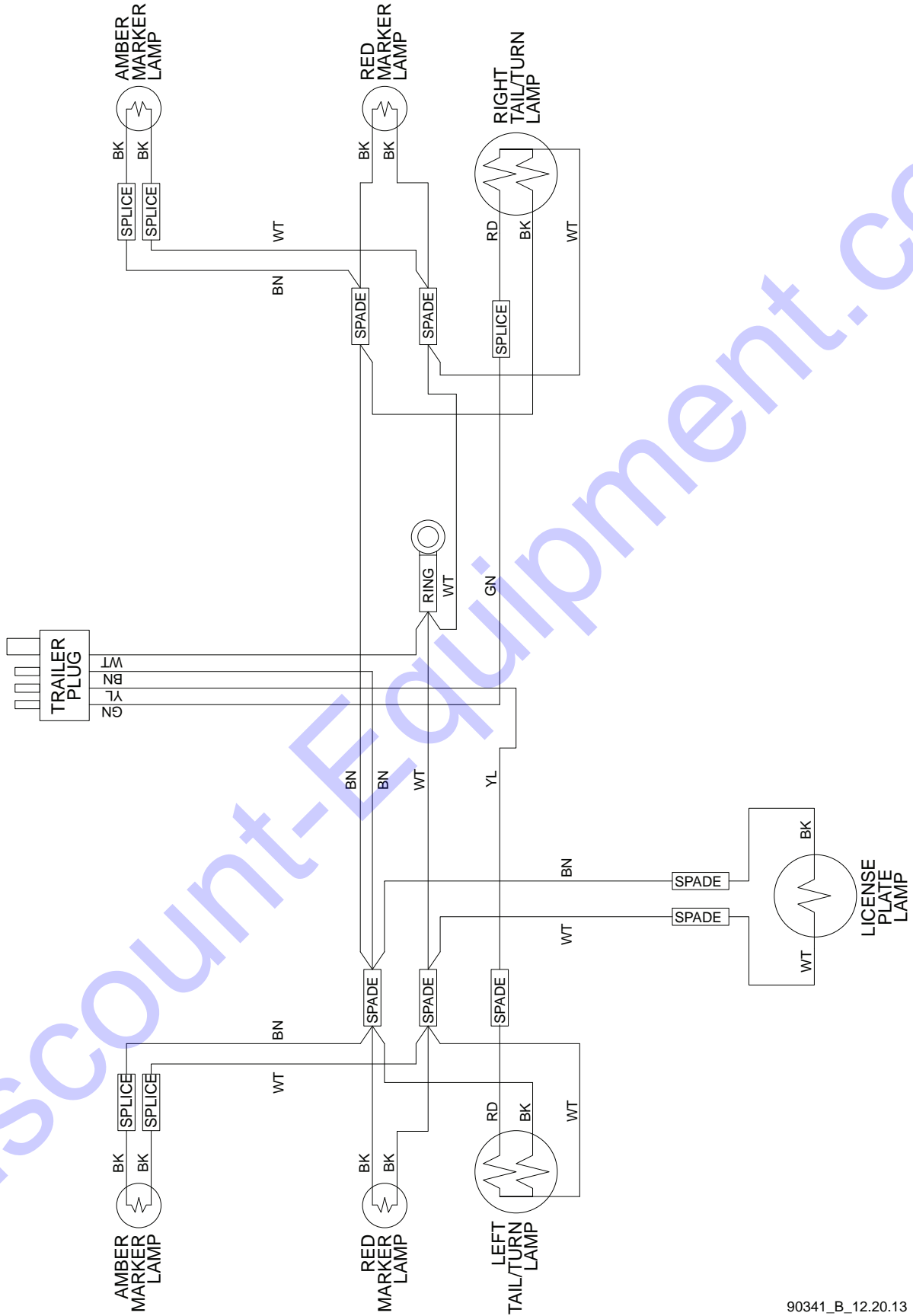

90341_B_12.20.13

TRAILER LIGHTS WIRING DIAGRAM - MTT20, MTT20CAN

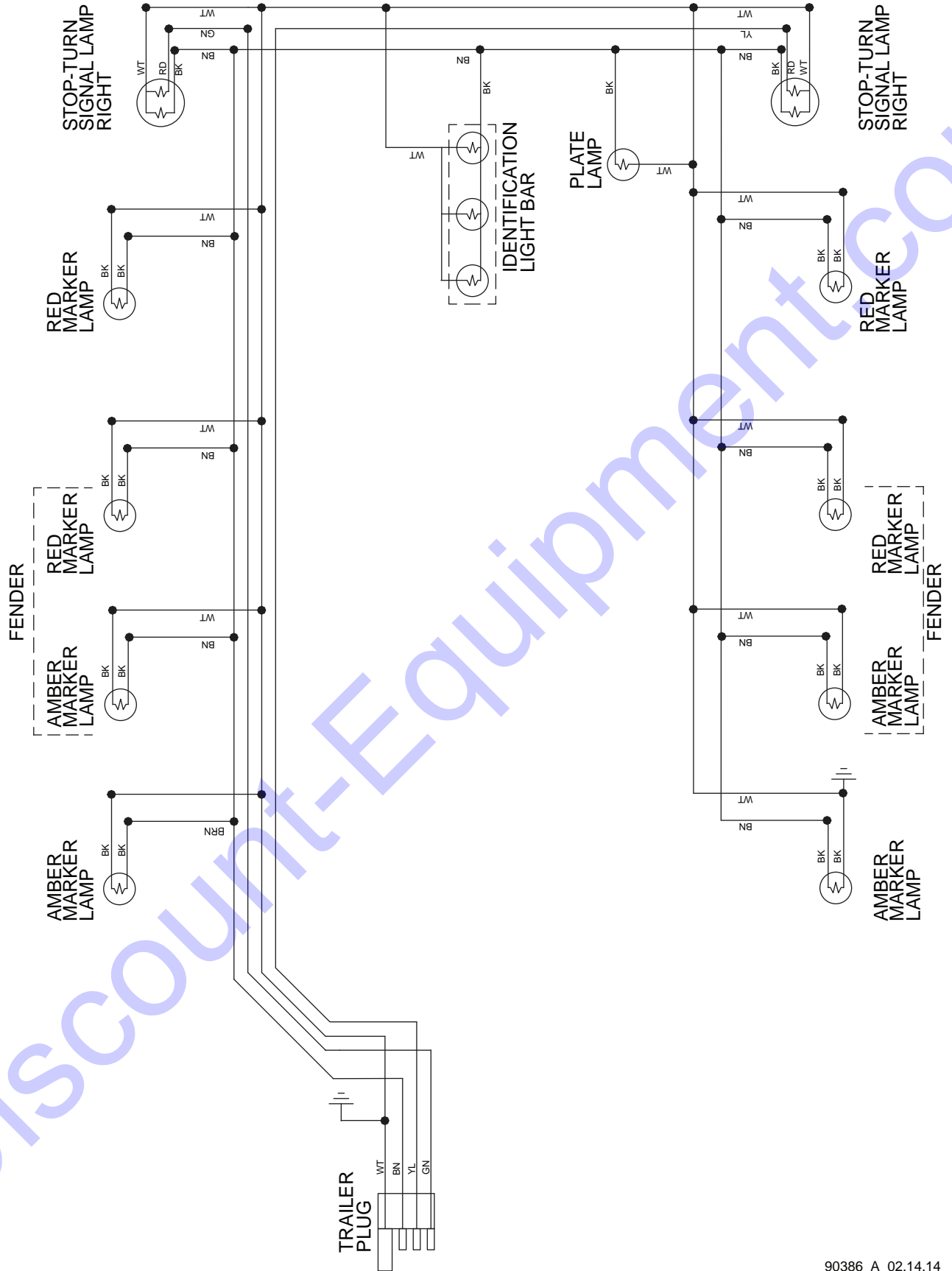

90386_A_02.14.14

ELECTRIC BRAKES WIRING DIAGRAM - MTT15

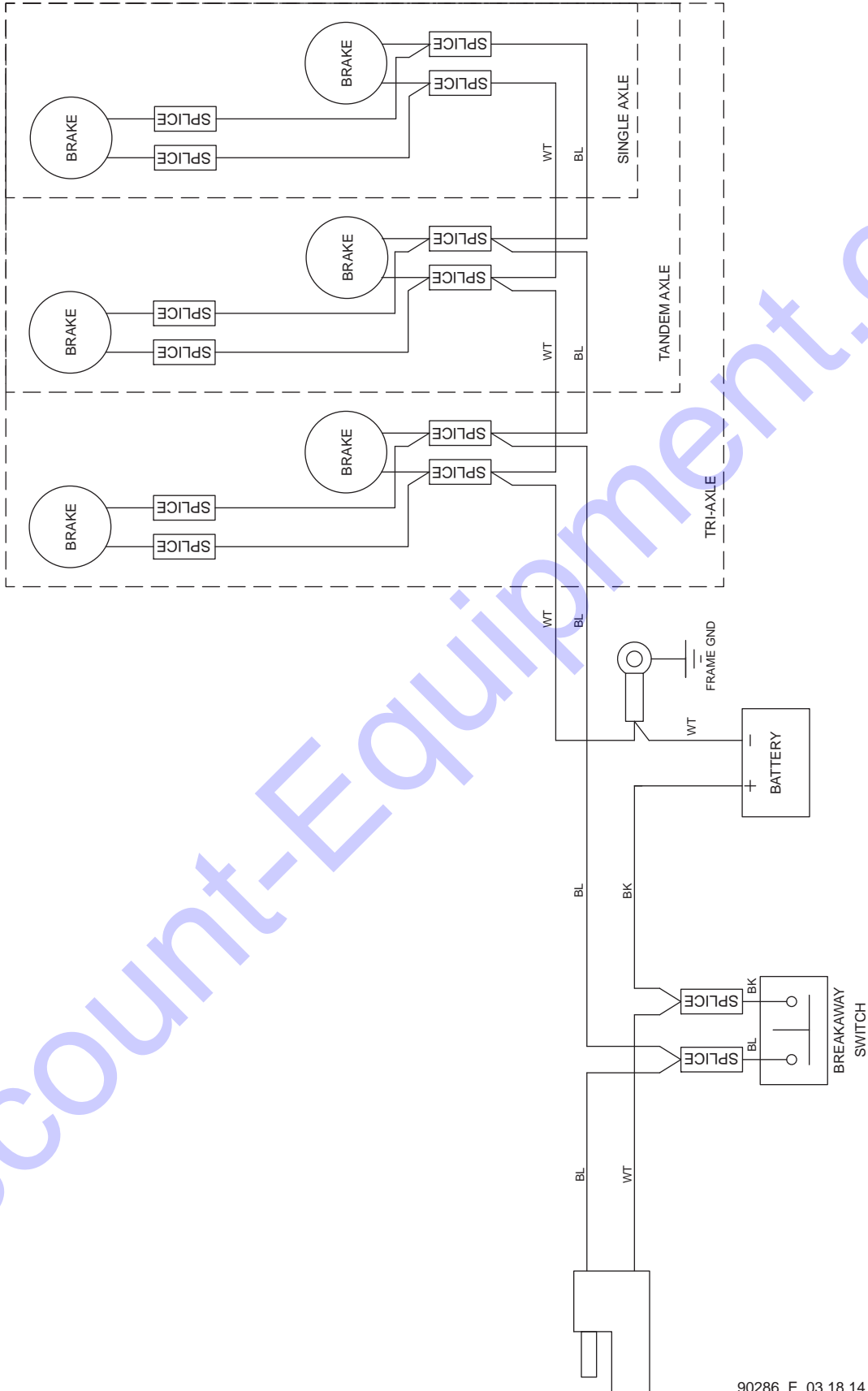

90286_E_03.18.14



www.discount-equipment.com

REV: E
PART NO: 40125
09.29.14