

ENGINE

- Deutz D 2.9 L4 – water-cooled, naturally aspirated diesel engine
 - 49 hp @ 2600 rpm
 - 4 cylinder
 - 2.9 Liter displacement
 - DOC only for exhaust after treatment
 - EPA Final Tier 4 approved
 - Steel, single wall fuel tank
 - 113 gal. (428 L) capacity / 100 gal. (379 L) usable
- Fuel consumption at prime: 100% - 3.60 gph (13.6 Lph)
- Cooling system capable of operating at 120°F (49°C) ambient
- Disposable air filter – paper element
- 950 CCA wet cell battery
- 95 Amp alternator
- Low coolant warning/shutdown

PUMP

- Cornell 4NNTL, Diaphragm Dry Prime Centrifugal Pump
- Diaphragm pump flow up to 50 SCFM
- 4 in. NPTF – suction & discharge connection
- Cast Iron ASTM A48 Class 30 pump casing
- Cast Iron ASTM A48, Class 30 impeller
- 2 vane, enclosed impeller
- Impeller design incorporated with deflector vanes and pumpout vanes
- Single mechanical seal, John Crane Type 1 & 2, with tungsten carbide vs silicon carbide faces
- Replaceable wear ring
- Run-dry system for continuous operations without need for external flush water or venting
- Pump shaft - 1144 stress-proof steel

PUMP PERFORMANCE

- Pump output – 1450 gpm (5489 Lpm)
- Lift suction – 28 ft. (8.5 m)
- Maximum diameter of solids – 3 in (76.2 mm)
- Impeller diameter: 8.25 in. (20.9 cm)
- Maximum efficiency (BEP Percent) – 80% BEP Flow – 870 gpm (3293 Lpm) @107ft.
- Total dynamic head – 165 ft. (50.29 m)
- Intake/Discharge height – 29.00 in. (73.7 cm)
- Duty Points:
 - 700 gpm (2650 Lpm) @ 60 ft. (18.3 m) TDH @ 1800 RPM, 78% efficiency, NPSHR 10 ft. (3.05 m)
 - 1,000 gpm (3785 Lpm) @ 104 ft. (31.7 m) TDH @ 2500 RPM, 79% efficiency, NPSHR 11 ft. (3.35 m)

FLOW CHART / PUMP CURVE

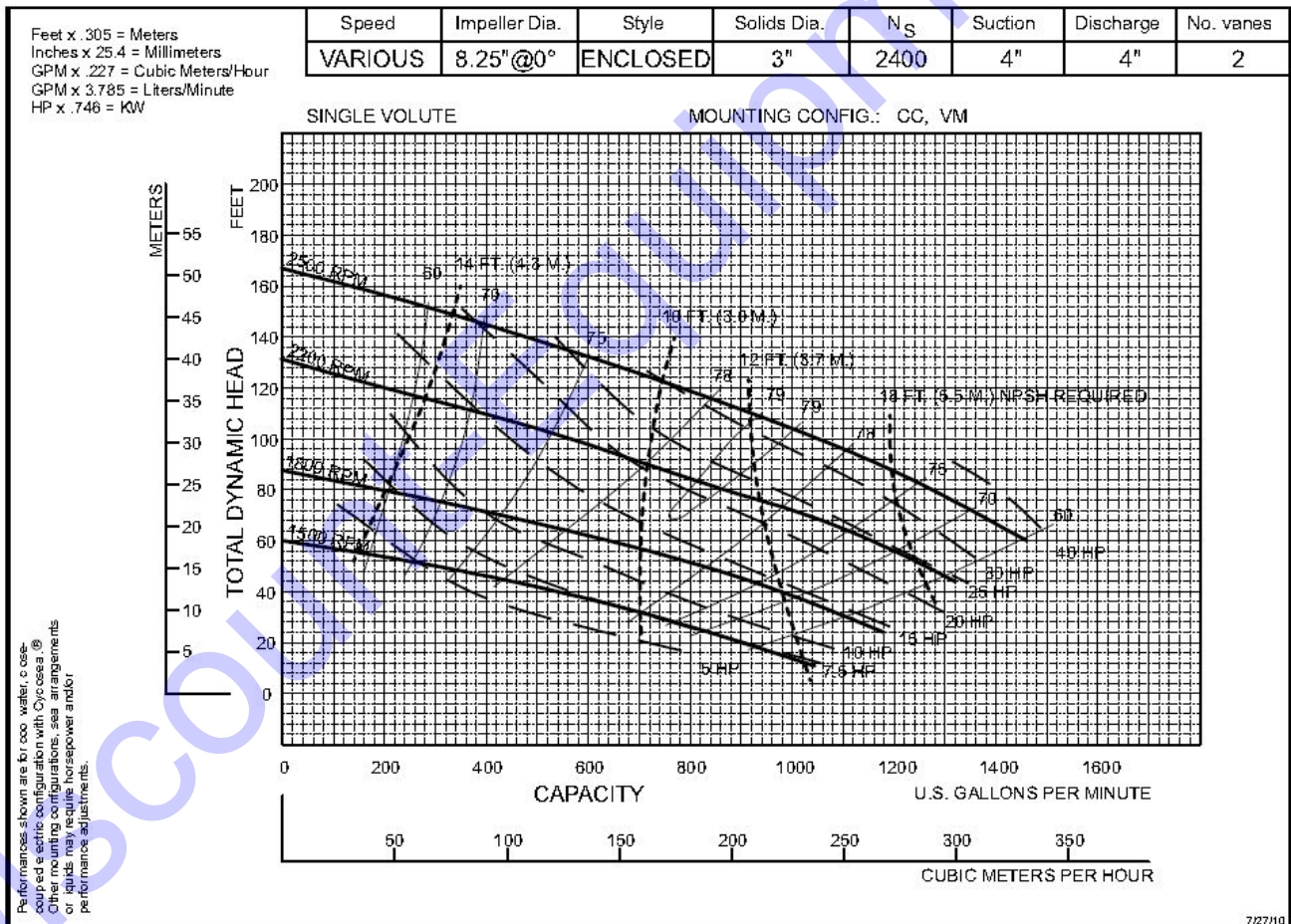

SYSTEM CONTROLS

- White LED lighting control panel lighting
- Standard controller – LOFA CP750
 - Large, backlit 4.3 in. (109 mm) LCD display
 - Displays engine temp, engine speed, fuel level, engine hrs., coolant temp, and oil pressure
 - Advanced automatic start/stop control for use with two-switch inputs and 4-20mA transducer
 - Configurable high and low set points control start/stop operation
 - Alarm output to signal start warning or shutdown conditions
 - Heavy-duty IP64 water-resistant key switch with booted key
 - RS485 serial interface for auxiliary equipment
 - Electronic e-stop with red LED engagement indicator light

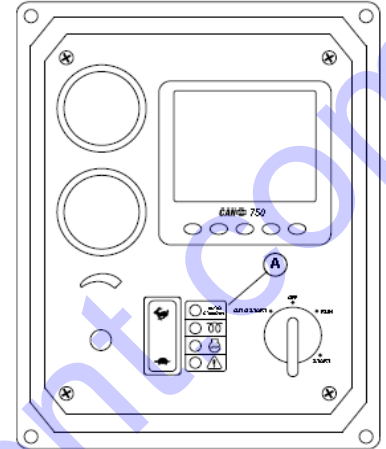

TRAILER

- Flip-tongue design
- Bolt-on, replaceable front tongue mounting plate
- DOT approved LED tail, side, brake, and directional lights
- (4) transportation tie downs capable of handling 3 in. (76.2 mm) trailer straps
- Safety chains with spring loaded safety hooks
- 2 in. (50.8 mm) adjustable ball hitch
- 6000 lb. (2722 kg) torsion axle with surge brakes
- 2000 lb. (907 kg) tongue jack with footplate
- (2) 2000 lb. (907 kg) top wind jacks, with option to add up to (4)
- ST225/75R15 tubeless tires – 8 ply
- UV & fade resistant, high temperature cured, black polyester power paint
- Central lifting point
- Document holder with operating manual including the AC/DC wiring diagrams

WEIGHT & DIMENSIONS

- Trailer Mounted
 - Dry weight: 3,586 lbs. (1,627 kg.)
 - Operating weight: 4,400 lbs. (1,996 kg.)
 - Dimensions: 150.12 x 75.00 x 73.88 in. (3.81 x 1.91 x 1.88 m)
- Skid Mount
 - Dry weight: 2,966 lbs. (1,345 kg.)
 - Operating weight: 3,780 lbs. (1,715 kg.)
 - Dimensions: 91.16 x 66.60 x 61.50 in. (2.32 x 1.91 x 1.88 m)

WARRANTY

1 Year, Unlimited Hours / 2 Years, 2000 Hours; See warranty policy for complete details



ENCLOSURE OPTION

- Aluminum, sound attenuated enclosure; insulated and baffled
- Field fitment of enclosure without need to modify trailer
- UV & fade resistant, high temperature cured, white polyester powder paint
- Stainless steel hinges on all doors
- Fully lockable enclosure including doors and fuel fill
- Rear cabinet opens to allow for full access to pump and bearing frame for ease of service or pump replacement without needing to remove any cabinet or panels
- (2) side access doors open 90 degrees for easy access to pump controller and engine service points with positive stay hinges
- Easy access from top of cabinet for radiator fill and inspection

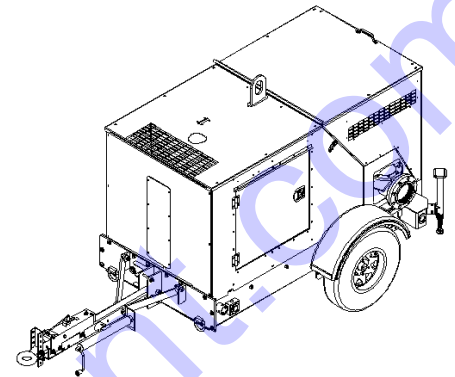
**WEIGHT & DIMENSIONS with ENCLOSURE**

- Trailer Mounted
 - Dry weight: 3,836 lbs. (1,740 kg.)
 - Operating weight: 4,650 lbs. (2109 kg.)
 - Dimensions: 150.12 x 75.00 x 73.88
- Skid Mount
 - Dry weight: 3,216 lbs. (1,459 kg.)
 - Operating weight: 4,030 lbs. (1,828 kg.)
 - Dimensions: 91.16 x 66.60 x 61.50

