

AIRMAN

PC

SERVICE MANUAL

SCREW COMPRESSOR

PDS400S-6C3 PDS400SC-6C3



www.discount-equipment.com

Discount Equipment

Discount-Equipment.com is your online resource for commercial and industrial quality parts and equipment sales.

Locations:

Florida (West Palm Beach): [561-964-4949](tel:561-964-4949)

Outside Florida TOLL FREE: [877-690-3101](tel:877-690-3101)

Need parts? Check out our website at www.discount-equipment.com

Can't find what you need?

Click on this link: <http://www.discount-equipment.com/category/5443-parts/> and fill out the request form.

Please have the machine model and serial number available in order to help us get you the correct parts. One of our experienced staff members will get back to you with a quote for the right part that your machine needs.

We sell worldwide for the brands: Genie, Terex, JLG, MultiQuip, Mayco, Toro/Stone, Diamond Products, Magnum, Airman, Mustang, Power Blanket, Nifty Lift, Atlas Copco, Chicago Pneumatic, Allmand Brothers, Essick, Miller Spreader, Skyjack, Lull, Skytrak, Tsurumi, Husquvarna/Target, Whiteman-Concrete/Mortar, Stow-Concrete/Mortar, Baldor, Wacker, Sakai, Snorkel, Upright, Mi-T-M, Sullair, Neal, Basic, Dynapac, MBW, Weber, Bartell, Bennar Newman, Haulotte, Ditch Runner, Blaw-Knox, Himoina, Best, Buddy, Crown, Edco, Wyco, Bomag, Laymor, Terremite, Barreto, EZ Trench, Takeuchi, Basic, Bil-Jax, Curtis, Gehl, Heli, Honda, ICS/PowerGrit, Puckett, Waldon, ASV, IHI, Partner, Imer, Clipper, MMD, Koshin, Rice, Gorman Rupp, CH&E, Cat Pumps, Comet, General Pump, Giant, AMida, Coleman, NAC, Gradall, Square Shooter, Kent, Stanley, Tamco, Toku, Hatz, Kohler, Robin, Wisconsin, Northrock, Oztec, Toker TK, Rol-Air, Small Line, Wanco, Yanmar

New Equipment - Used Equipment - Rental Equipment - Parts and Accessories

Discount Equipment

www.discount-equipment.com

561-964-4949

Parts: wbparts@Discount-Equipment.com

Sales: info@Discount-Equipment.com

Preface

This service manual explains about the cautions for maintenance jobs and is to serve a guide for the electric system, and troubleshooting for service personnel. Fundamental matters and other things already mentioned in the “Instruction Manual” and the “Parts Catalogue” are omitted to avoid duplication. Therefore, for the operation and handling of this unit, we request you to refer to the instruction manual and caution plates, and further for the structure and components of the unit, please refer to the “Parts Catalogue” separately to be supplied with the unit.

If you should find any description which does not coincide with the instruction manual and parts catalog, we request you to make sure to start the job after clarifying it.

Service personnel is required to safely take quick and proper countermeasures as well as to use correct technology of maintenance in case of field services and periodical maintenance. It is important that service personnel should have proper and sufficient knowledge about the structure and function of the unit and should be well familiar with such technique mentioned in them.

Regarding the part numbers mentioned in this manual, we request you to refer to the Parts catalogue separately supplied together with the unit, because the parts numbers in this manual are sometimes changed.

Copies of this service manual are intended to be distributed to limited numbers of our customers. The unauthorized reproduction or distribution of this service manual is prohibited.

Table of Contents

1. Specification	1-1
1.1 Specifications	1-1
1.2 Set Value	1-2
1.3 Outline Drawing	1-3
1.4 Internal Components and Part Names	1-5
1.5 Instrument Panel	1-8
1.5.1 Indicator lamp·Warning / Emergency display	1-9
1.6 Capacity Control Device	1-10
1.7 Piping Diagram	1-12
1.8 Fuel Piping	1-14
2. Maintenance	2-1
2.1 Cautions for Overhauling	2-1
2.1.1 Precautions before starting work	2-1
2.1.2 Disassembly and reassembly	2-1
2.2 Tightening Torque	2-3
2.2.1 General bolts and nuts tightening torque	2-3
2.2.2 Tightening torque of such important quality parts as bolts and nuts	2-4
2.3 How to Adjust Regulator	2-7
2.4 Maintenance and Adjustment of Pressure Control Valve	2-8
2.5 Change O-ring of Unloader	2-10
2.6 Change O-ring of Auto-relief Valve and Vacuum Relief Valve	2-10
2.7 Change Oil Separator	2-11
2.8 Change of Pellet assembly of By-pass Valve	2-12
2.9 Clean the Strainer Provided inside the Engine Feed Pump	2-13
2.10 Supply Grease to Trailer Hub Bearing	2-13
2.11 Supply Grease to Leaf Spring Pin	2-13
2.12 Check and Confirm that the Fixing Bolts for the Drawbar are Properly Tightened	2-13
2.13 Manual Air Bleeding Method for Fuel Line System	2-14
2.14 Clean inside of Fuel Tank	2-14
2.15 Clean Drain Separator (Aftercooler type only)	2-15
2.16 Values of Various Adjustments of Engine	2-15
2.17 Suction Control Valve (SCV) Replacement Procedure	2-16
3. Electric System	3-1
3.1 Electronic Control System of Engine	3-1
3.1.1 Electronic control fuel injection system (Common rail type)	3-1
3.1.2 EGR (Exhaust gas recirculation) control	3-3
3.1.3 Acceleration control	3-4
3.1.4 Preheating control	3-4
3.2 Accelerator Controller	3-5
3.3 Engine Controller (ECM)	3-8
3.4 Emergency Controller	3-17
3.5 Alternator	3-25
3.6 Starter	3-26
3.7 Solenoid Valve for Starting Unloader	3-27
3.7.1 Unloader piston actuation:SV1	3-27
3.7.2 Unloader spring chamber negative pressure:SV2	3-27
3.8 Air Filter Indicator (Engine / Air-end common)	3-28
3.9 Pressure Sensor (Secondary pressure of regulator detect)	3-28

Table of Contents

3.10 Discharge Air Temperature·Separator Air Temperature·Engine Coolant Temperature Sensor (Thermister) -	3-29
3.11 Fuel Meter (Display) -----	3-29
3.12 Sending Unit -----	3-30
3.13 Fuel Air-bleeding Electromagnetic Pump (Type with built-in filter) -----	3-31
3.14 Main·Safety Relay, MR·SR -----	3-31
3.15 Electromagnetic Pump Relay, FR -----	3-32
3.16 Glow Relay, GR -----	3-32
3.17 Starter Relay, SY -----	3-32
3.18 Electronic Control Engine Component -----	3-33
3.18.1 Supply pump -----	3-34
3.18.2 Suction control valve (SCV) -----	3-34
3.18.3 Fuel temperature (FT) sensor -----	3-35
3.18.4 Common rail -----	3-35
3.18.5 Pressure limiter -----	3-36
3.18.6 Common rail pressure sensor -----	3-36
3.18.7 Injector -----	3-37
3.18.8 Engine coolant temperature (ECT) sensor -----	3-37
3.18.9 Crankshaft position (CKP) sensor -----	3-38
3.18.10 Camshaft position (CMP) sensor -----	3-39
3.18.11 Engine oil pressure sensor -----	3-39
3.18.12 Barometric pressure sensor -----	3-40
3.18.13 Intake air temperature (IAT) sensor -----	3-40
3.18.14 EGR position sensor -----	3-41
3.18.15 Boost pressure sensor -----	3-42
3.18.16 Boost temperature sensor -----	3-42
4. Troubleshooting -----	4-1
4.1 Repairing Procedures -----	4-1
4.1.1 Safety caution -----	4-1
4.1.2 Caution during failure diagnosis -----	4-1
4.1.3 How to use the failure diagnosis -----	4-2
4.2 Failures of Compressor and Engine -----	4-3
4.2.1 At start-up, starter rotates slowly -----	4-3
4.2.2 Starter turns, but engine will not start -----	4-3
4.2.3 Engine will not turn to meet rated pressure -----	4-3
4.2.4 Engine revolutions will drop before rises up to rated pressure -----	4-4
4.2.5 Engine will not turn to meet rated revolutions -----	4-4
4.2.6 Minimum speed not available even upon no-load operation -----	4-5
4.2.7 Safety valve bursts out during unloaded operation -----	4-5
4.2.8 Oil mixed found in delivery air -----	4-6
4.2.9 Water found mixed in discharge air (Aftercooler type) -----	4-6
4.2.10 Discharge air is insufficient -----	4-7

Table of Contents

4.3	Operation of Emergency Switch	4-8
4.3.1	Discharge air temperature (or separator air temperature) is displayed abnormality-code and engine will stop	4-8
4.3.2	Engine oil pressure is displayed abnormality-code and engine will stop	4-9
4.3.3	Engine coolant temperature is displayed abnormality-code and engine will stop	4-10
4.3.4	Engine RPM drop is displayed abnormality-code and engine will stop	4-10
4.4	Others	4-11
4.4.1	Abnormality-code is not shown, engine will stop	4-11
4.5	Explanation of Trouble Diagnosis	4-12
4.6	Engine Trouble Diagnosis Function	4-14
4.6.1	Engine trouble diagnosis	4-14
4.6.2	How to delete diagnostic trouble codes (DTC)	4-18
4.6.3	List of diagnostic trouble codes (DTC)	4-19
4.6.4	Diagnostic service tool (EMPSⅢ)	4-32
5.	References	5-1
5.1	Consumable Parts and Electrical Appliances	5-1
5.2	Engine Wiring Diagram	5-3

1. Specification

1.1 Specifications

Item	unit	PDS400S<SC>-6C3
●Weight · Mass		
Overall length	in.(mm)	172.0(4,370)
Overall length (Bonnet only)	in.(mm)	105.5(2,680)
Overall width	in.(mm)	77.8(1,975)
Overall height	in.(mm)	65.0(1,650)
Tire		To be locally procured
Net dry mass	lb(kg)	4,189<4,244> (1,900<1,925>)
Operating mass	lb(kg)	4,652<4,707> (2,110<2,135>)
●Compressor		
Free air delivery	cfm(m ³ /min)	400(11.3)
Working pressure	psi(MPa)[bar]	100(0.69)[6.9]
Pressure of pressure control valve	psi(MPa)[bar]	58(0.4)[4.0]
Burst pressure of safety valve	psi(MPa)[bar]	150(1.03)[10.3]
Ambient conditions: temperature	°F(°C)	-59 to +104(-15 to +40)
Ambient conditions: altitude	yd(m)	less than 1,640(1,500)
●Engine		
Type		ISUZU CI-4JJ1XYCD-01 ISUZU CI-4JJ1XYCD-01G
Rated output	hp/min ⁻¹ (kW/min ⁻¹)	113.2/2,200(84.4/2,200)
Fuel consumption	g/kW·h	209
Rated RPM	min ⁻¹	2,200
RPM at unload conditions	min ⁻¹	1,300
Net dry mass	lb(kg)	639(290)
●Lubricating oils		
Engine oil capacity (H/L level)	gal.(L)	3.9/2.9(15/11)
Compressor oil capacity (including receiver tank and oil cooler etc.)	gal.(L)	13.5(51)
Compressor oil		Ambient temperature: 5°F to 104°F (-15°C to +40°C) HULS : ANDEROL 3032 MOBIL : RARUS SHC 1024 TEXACO: SYN-STAR DE 32
Coolant capacity	gal.(L)	2.9(11)
Fuel tank capacity	gal.(L)	47(178)
●Fuel consumption ratio (for reference only)		
At no load	gal./Hr(L/Hr)	2.1(7.8)
At 50%	gal./Hr(L/Hr)	3.4(12.6)
At 70%	gal./Hr(L/Hr)	4.0(15.1)
At full load	gal./Hr(L/Hr)	4.9(18.7)

1. Specification

1.2 Set Value

Item	unit	PDS400S<SC>-6C3
●Emergency stop devices		
Discharge air temperature	°F(°C)	248(120)
Coolant temperature	°F(°C)	221(105)
Engine oil pressure abnormality	psi(MPa)[bar]	14.6(0.1)[1.0]
Discharge air temperature at separator	°F(°C)	248(120)
Engine speed down	min ⁻¹	1,200
Discharge air temperature sensor disconnection	-	Detection of disconnection
Discharge air temperature sensor disconnection at separator	-	Detection of disconnection
●Warning devices		
Discharge air temperature	°F(°C)	239(115)
Coolant temperature	°F(°C)	212(100)
Compressor air filter clogging	psi(kPa)[bar]	0.9(6.23)[0.0623]
Engine air filter clogging	psi(kPa)[bar]	0.9(6.23)[0.0623]
Battery abnormality	-	When not charged
Discharge air temperature at separator	°F(°C)	239(115)
Boost temperature rise	°F(°C)	185(85)
Coolant temperature sensor disconnection	°F(°C)	Detection of disconnection
●Set value		
Pressure control valve	psi(MPa)[bar]	58(0.40)[4.0]
Actuating pressure of safety valve	psi(MPa)[bar]	150(1.03)[10.3]
Unload starting pressure	psi(MPa)[bar]	100(0.69)[6.9]
●Engine RPM		
Rated RPM	min ⁻¹	2,200
RPM at no load	min ⁻¹	1,300
●Indications of gauges or instruments during operation		
Discharge pressure gauge(at full load)	psi(MPa)	58 to 100(0.40 to 0.69)
Discharge pressure gauge(at no load)	psi(MPa)	100 to 123(0.69 to 0.85)

1. Specification

1.3 Outline Drawing

Unit : in.

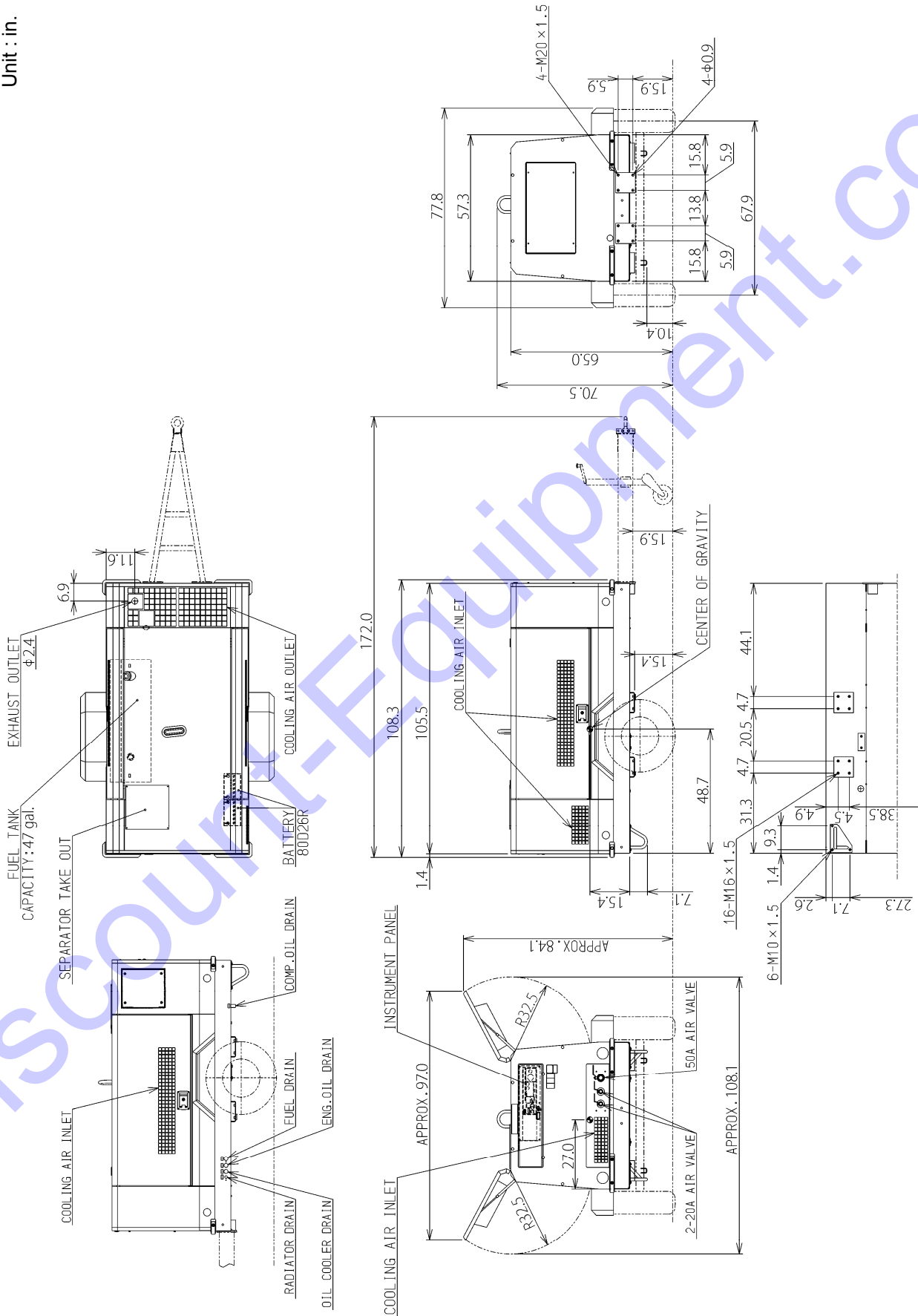

PC14064E

1. Specification

1.4 Internal Components and Part Names

[Standard type]

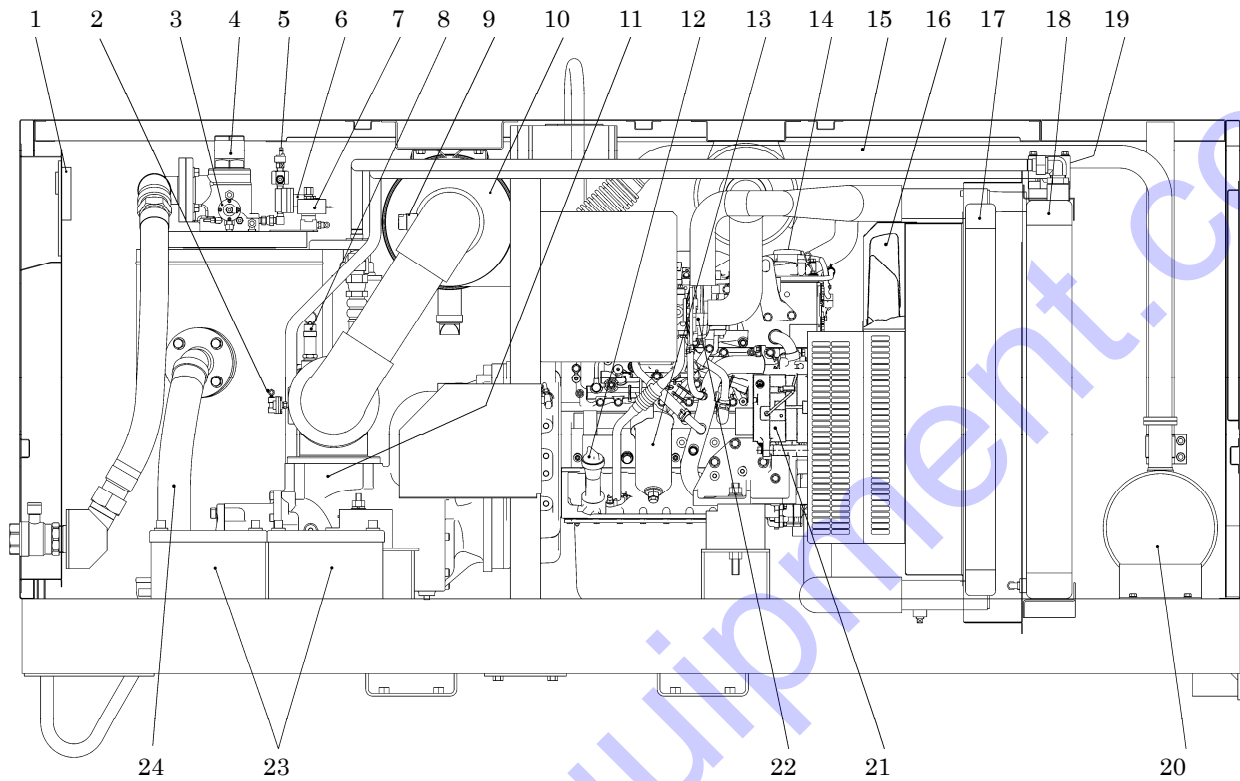

PC13022

PDS400S-6C3

No.	Description	No.	Description
1	Control panel	13	Engine oil filter
2	Auto-relief valve	14	Engine
3	Vacuum relief valve	15	Exhaust pipe
4	Pressure control valve	16	Fan
5	Pressure sensor	17	Intercooler
6	Pressure regulator	18	Oil cooler
7	Solenoid valve for starting unloader (SV2)	19	By-pass valve
8	Safety valve	20	Exhaust muffler
9	Air filter indicator	21	Alternator
10	Air filter (For compressor air-end)	22	Turbo charger
11	Air-end	23	Battery
12	Engine oil filler port (Used as oil level gauge)	24	Discharge pipe

1. Specification

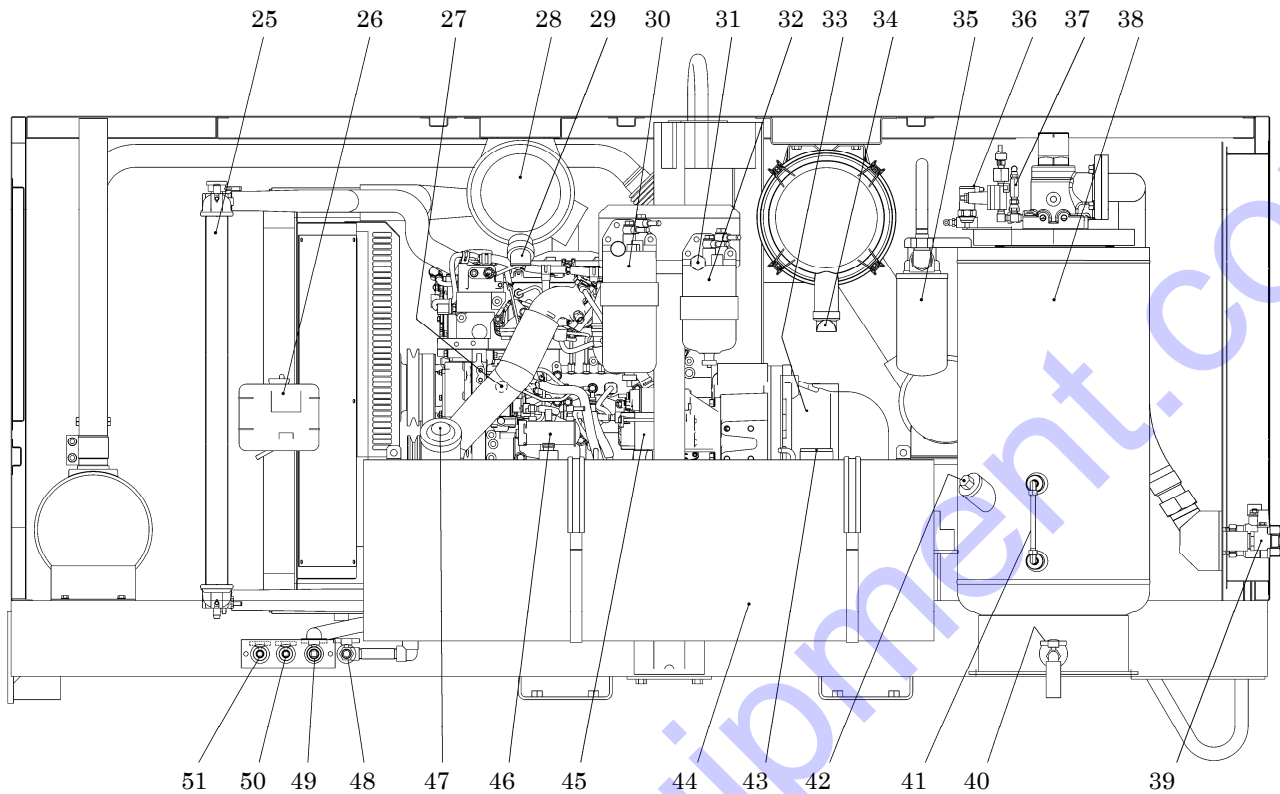

PC13023

PDS400S-6C3

No.	Description	No.	Description
25	Radiator	39	Service valve
26	Reserve tank	40	Separator receiver tank drain valve
27	Supply pump	41	Compressor oil level gauge
28	Air filter (For engine)	42	Compressor oil filler port
29	Vacuator valve (For engine)	43	Sending unit
30	Fuel pre-filter	44	Fuel tank
31	Priming pump	45	Starter
32	Fuel filter	46	Fuel air-bleeding electromagnetic pump
33	Coupling	47	Fuel filler cap
34	Vacuator valve (For compressor air-end)	48	Fuel tank drain valve
35	Compressor oil filter	49	Engine oil drain valve
36	Solenoid valve for starting unloader (SV1)	50	Oil cooler drain valve
37	Valve for low temperature start	51	Radiator drain valve
38	Separator receiver tank		

1. Specification

[Aftercooler type]

Only the special devices additionally or optionally attached to the standard machine are shown in the following figure. For the details of the other standard devices, refer to page 1-5 & 1-6.

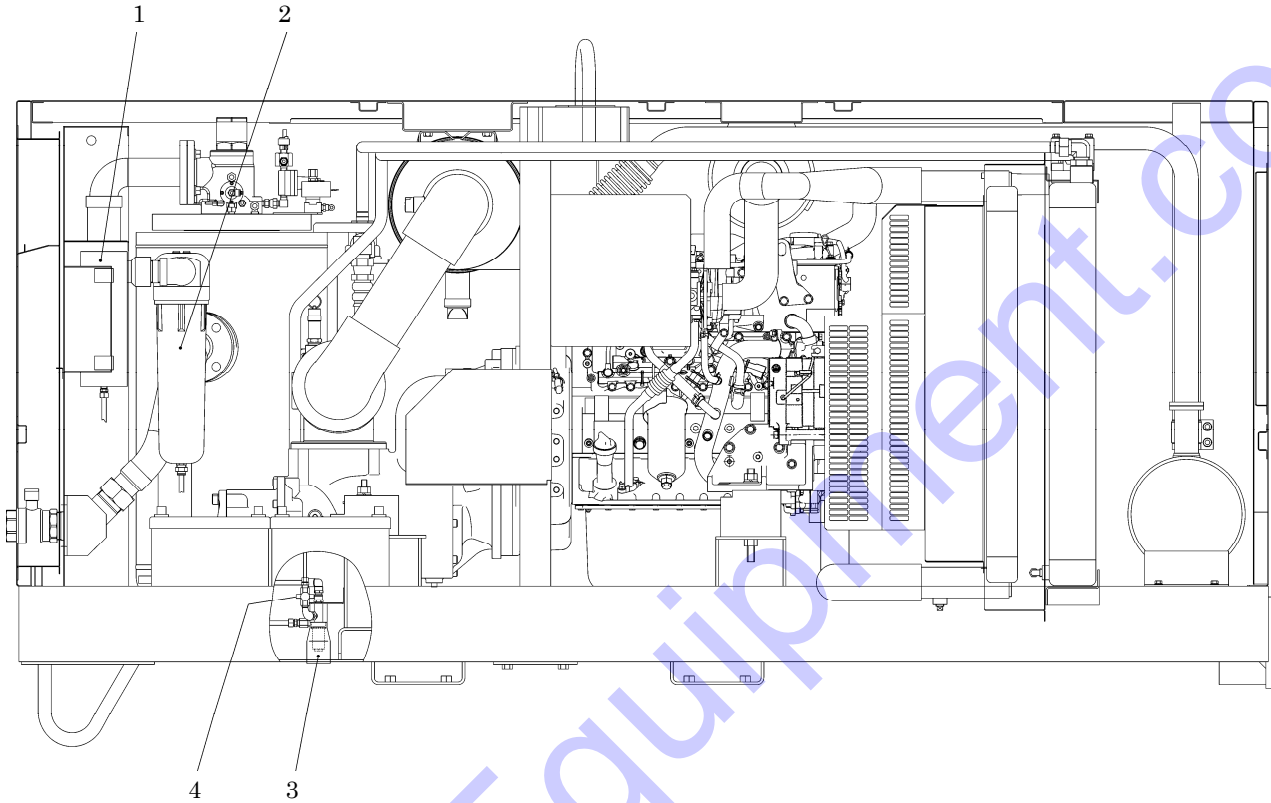

PC13024

PDS400SC-6C3

No.	Description	No.	Description
1	Aftercooler	3	Drain port of aftercooler
2	Drain separator	4	Drain warming valve

1. Specification

1.5 Instrument Panel

Each display of the operation panel is illustrated as follows.

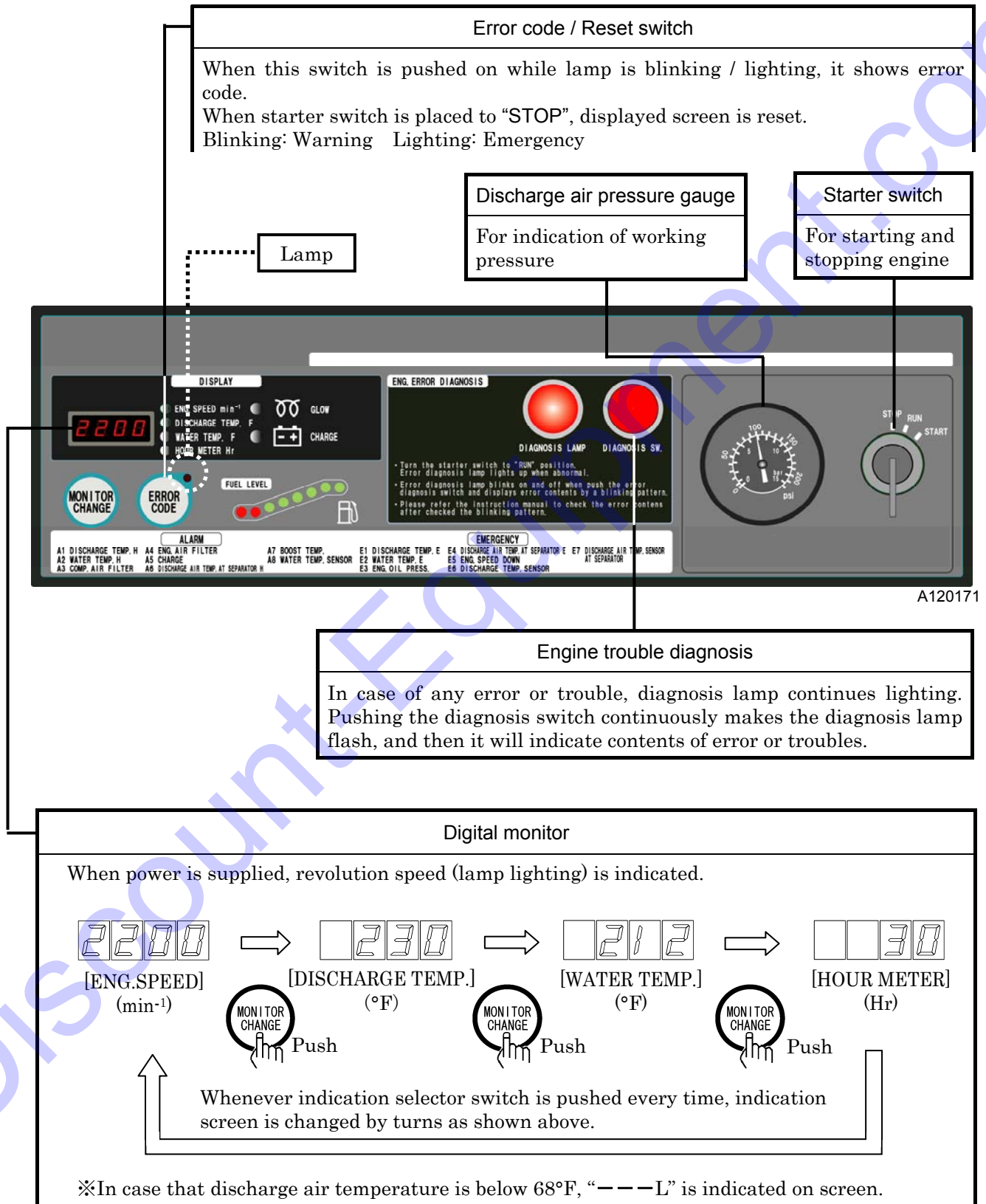

Read and fully understand the explanations and be sure to operate safely:



1. Specification

1.5.1 Indicator lamp · Warning / Emergency display

[Indicator lamp] Turn the starter switch to “RUN” position. Then the lamp goes on.

Item	Contents	Measures	Monitor
GLOW	When starter switch is placed to “RUN”, the lamp goes on and after preheating is finished, the lamp will be off.	—	
CHARGE	Lamp goes on when alternator is not charging.	Check wiring Check alternator	

[Warning display] This displays such trouble of less importance when it occurs during operation, but the unit continues operating.

When any abnormality happens, a ERROR CODE lamp flickers. In this time when ERROR CODE switch is pressed, a error code will be displayed.

Item	Error code	Contents	Warning set value
DISCHARGE TEMP. H	A1	When air temperature at the outlet of the air-end reaches warning temperature.	239°F(115°C)
WATER TEMP. H	A2	When coolant temperature reaches warning temperature.	212°F(100°C)
COMP. AIR FILTER	A3	When air filter gets clogged and suction resistance increases.	0.062bar (6.23kPa)
ENG. AIR FILTER	A4		
CHARGE	A5	Belt loosened and/or cut Faulty generation of alternator	—
DISCHARGE AIR TEMP. AT SEPARATOR	A6	When air temperature at the outlet of the separator reaches warning temperature.	239°F(115°C)
BOOST TEMP.	A7	When boost temperature reaches warning temperature.	185°F(85°C)
WATER TEMP. SENSOR	A8	When engine coolant temperature sensor is disconnected.	—

[Emergency display] When any trouble takes place during operation, this displays and it stops as an emergency stop.

When any abnormality happens, a ERROR CODE lamp lights. In this time when ERROR CODE switch is pressed, a error code will be displayed.

Item	Error code	Contents	Abnormal set value
DISCHARGE TEMP. E	E1	When air temperature at the outlet of the air-end reaches abnormal temperature.	248°F(120°C)
WATER TEMP. E	E2	When coolant temperature reaches abnormal temperature.	221°F(105°C)
ENG. OIL PRESS.	E3	When engine oil pressure drops.	1.0bar (0.1MPa)
DISCHARGE AIR TEMP. AT SEPARATOR	E4	When air temperature at the outlet of the separator reaches abnormal temperature.	248°F(120°C)
ENG. SPEED DOWN	E5	When engine revolution speed drops.	Lower than 1,200min ⁻¹
DISCHARGE TEMP. SENSOR	E6	When air temperature sensor at the outlet of the air-end is disconnected.	—
DISCHARGE AIR TEMP. SENSOR AT SEPARATOR	E7	When air temperature sensor at the outlet of the separator is disconnected.	—

1. Specification

1.6 Capacity Control Device

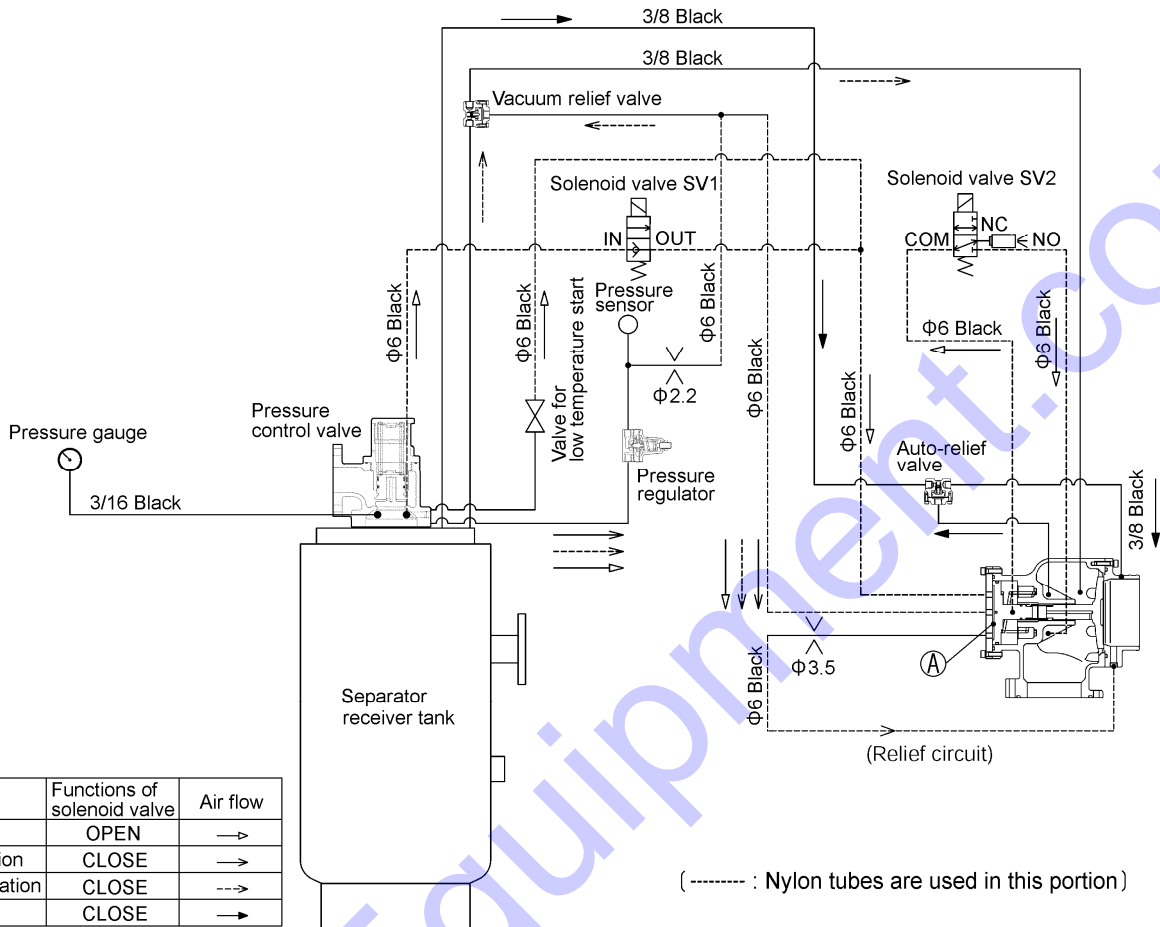

PC13052-3E

Step	Response
Start	<p>Compressed air is sent into the unloader chamber (A) through starting unloader solenoid valve SV1 to fully open the unloader valve. Further, as COM-NC for the solenoid valve SV2 is connecting, the spring chamber becomes negative pressure, and unloader valve fully closes at lower pressure. Thus starting unloader operation is performed.</p> <ul style="list-style-type: none"> ● In cold seasons, it opens the low temperature starting valve, and it sends compressed air in separator receiver tank into the unloader and the unloader valve can be fully closed at low pressure. Thus, the load for starting can be reduced. ● SV1 and SV2 solenoid valves operate 30 seconds at the discharge air temperature of higher than 10°C, and the temperature should be higher than 10°C or it operates 120 seconds. ● Engine (revolution) speed is fixed at 1,600min⁻¹ for the above mentioned operation conditions.
Load operation	<p>So that SV1 and SV2 solenoid valves are to be closed, the flow of air sent into the chamber (A) increases and decreases according to the increase and decrease of discharge pressure. Accordingly, the position of unloader valve and engine (revolution) speed change. Automatically discharge air volume can be controlled steplessly from 0 – 100%.</p>

1. Specification

Step	Response
Suction port closing unload operation	<p>When air consumption decreases and it exceeds the rated pressure, the pressure regulator operates to close the unloader valve. At the same time, the pressure sensor provided at the secondary side of pressure regulator detects and sends to engine controller the signal of engine speed lowering. At the unload condition, the inside of air end becomes high vacuum and it causes vacuum noise. In order to prevent this noise, it opens vacuum relief valve to prevent the compressor air end from becoming vacuum.</p> <ul style="list-style-type: none">● Engine (revolution) speed at unload conditions is operated at $1,600\text{min}^{-1}$ under less than discharge air temperature less than 60°C, and when it becomes higher than 60°C, the speed will be $1,300\text{min}^{-1}$.
Stop	Detecting the pressure inside compressor air end, the auto-relief valve operates, and the compressed air in separator receiver tank is automatically relieved to the atmosphere from unloader primary side.

1. Specification

1.7 Piping Diagram

[Standard type]

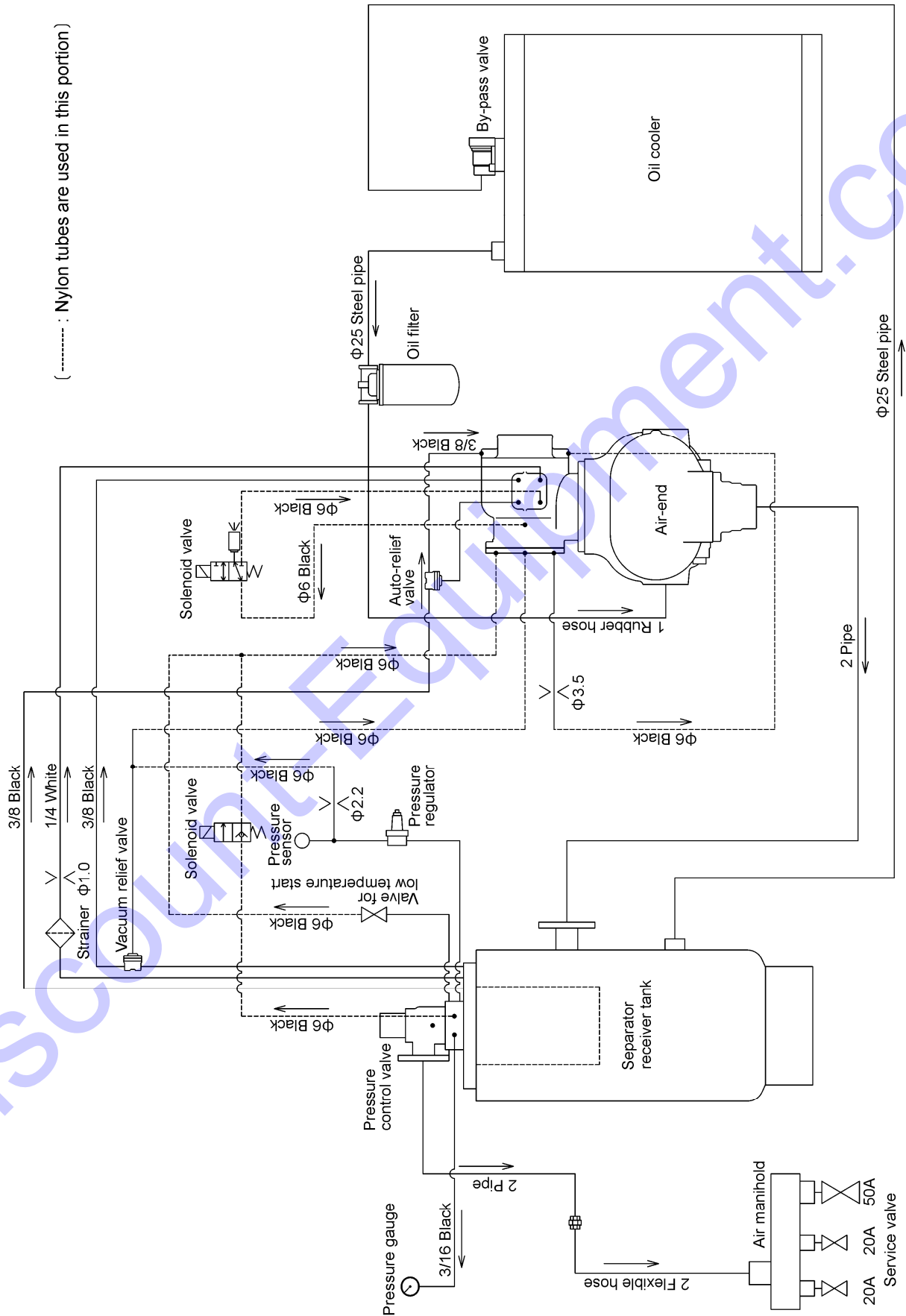

(- - - - - : Nylon tubes are used in this portion)

A120194E

1. Specification

1.8 Fuel Piping

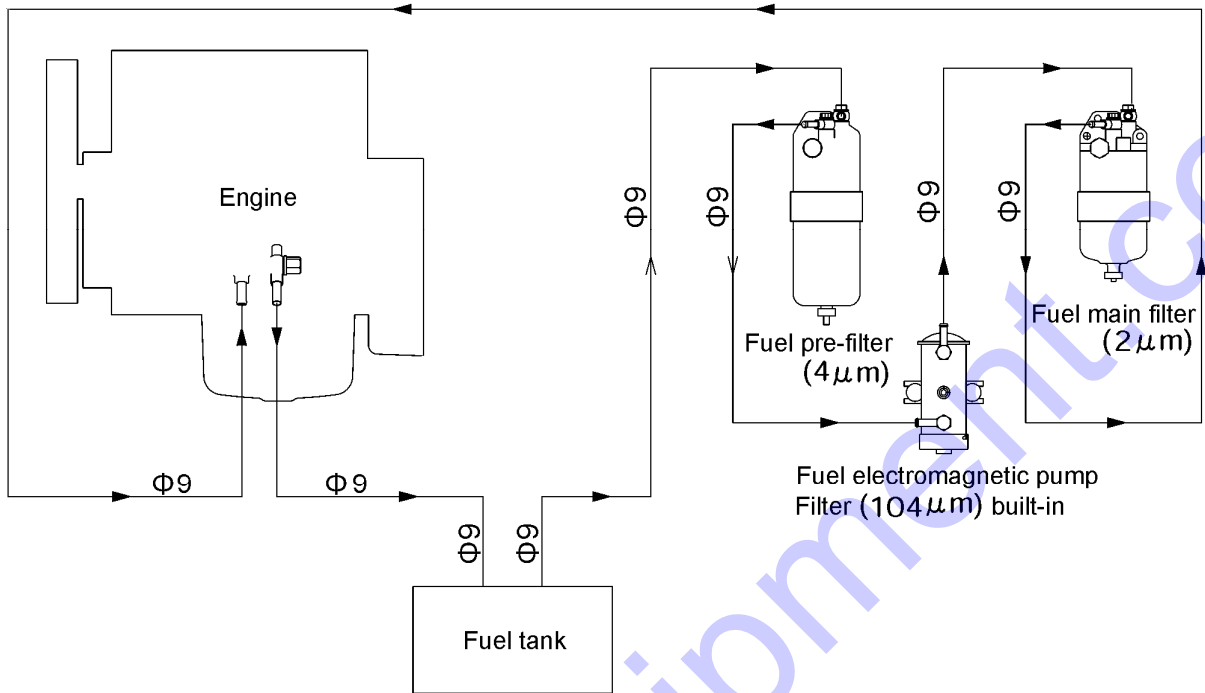

PC13053E

2. Maintenance

2.1 Cautions for Overhauling

2.1.1 Precautions before starting work

(1) Work to be performed

It is very important to always plan in advance what facilities, tools, instruments, materials, oil, etc. you will need to use; the exact locations and methods of performing inspection, adjustment, or disassembly; and the key points of any repair work to be performed.

(2) Care not to spill oil

Use a pan to collect used compressor oil, engine oil when changing the oil or attaching or detaching an oil line. If a large volume of oil is expected to flow out, make sure to drain any accumulated oil from the reserve tank, engine oil pan in advance.

[Follow the designated regulations to dispose of compressor oil and engine oil.]

(3) Care when detaching parts

When disassembling a complicated part, put a matching mark to indicate the position of detached parts for future reference. Make sure that the negative –cable is detached from the battery terminals before starting repair work.

(4) Use genuine parts

Make sure to use genuine parts when changing parts. Otherwise, it degrades performance and it shortens machine life.

(5) Tools to be prepared

- | | |
|---|---|
| ① Measuring instruments
(e. g. tester, insulation resistance gauge etc.) | ⑨ Grease |
| ② Tools | • Lithium based all-purpose grease
[CALTEX MULTIFAK EP1] |
| ③ Torque wrenches | • Lithium natrium based heat resistant
grease [MULTINOC SDX] |
| ④ Jigs and specialized tools | ⑩ Diesel oil |
| ⑤ Sealing tape (GAFLON seal tape) | ⑪ Compressor oil |
| ⑥ Liquid gasket (THREEBOND 1212) | ⑫ Cleaning cloths |
| ⑦ Lubricant (NICHIMOLY LAP spray or equivalent) | ⑬ Literatures (such as manuals etc.) |
| ⑧ Molybdenum sulfide (Paste spray type) | |

2.1.2 Disassembly and reassembly

- ① Select such a place for component disassembly where it is enough spacious and shall be dust-free.
- ② Clean also the surroundings of the part or component to be disassembled, removing smudge and adhesive matter by washing them.
- ③ Before removing nylon tubes, hydraulic hoses and also fuel hoses, clean the inside of the machine unit. And also cover all the openings of them temporally to prevent foreign matter and dust from entering inside.
- ④ When dismantling the disassembled parts or component, wash their surfaces well and place them on clean paper or cloth so that they can be kept clean and from being damaged.
- ⑤ Check each part for any dirt and discoloration. Then wash it in detergent oil (diesel oil) slightly. However, do not wash rubber parts with diesel oil.
- ⑥ Be careful not to damage disassembled parts, they are precision built.
- ⑦ Replace consumables such as oil seals, O-rings, filters, oil, etc. with new items when reassembling parts.
- ⑧ Apply “CALTEX MULTIFAK EP1” to O-ring surface and “MULTINOC SDX” to sliding portion of oil seal.
- ⑨ When reassembling, place the parts or components according to reassembling order and reassemble them correctly without any part un-reassembled and un-used.
- ⑩ When reassembling an assembled part (set part), be sure to replace it as an assembly.

2. Maintenance

- ⑪ Make sure to follow the tightening torque and clearance when reassembling the disassembled parts or components.
- ⑫ If the parts or components which are being disassembled are left untreated, ambient humidity or dirt may cause rust or corrosion. If it is unavoidably necessary to stop disassembling job on the way, make sure to protect them against rust and dirt.
- ⑬ After finishing the disassembling job, make sure to check the assembled unit for the direction of rotation, rotation speed and oil leak.
- ⑭ At first, perform trial operation at so slow speed that it may not cause seizure or overheating.

Discount-Equipment.com

2. Maintenance

2.2 Tightening Torque

2.2.1 General bolts and nuts tightening torque

Fasten all the bolts and nuts with the specified tightening torque when assembling.

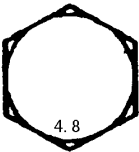
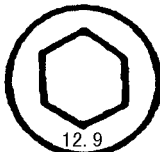
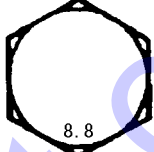
Kind Strength and sorting	Low or Middle carbon steel bolt (SS400B etc...)		High tensile strength bolt (SCM435 etc...)		
	4.6-6.8 (4T-6T)		8.8-12.9 (7T-12T)		
Width of across flat· Tightening torque					
	Hexagon bolts		Socket bolts		Hexagon bolts
Bolt diameter in. (mm)	Hexagon bolts Width of across flat in. (mm)	Tightening torque lbf·in.(N·m) [kgf·cm]	Socket bolts Width of across flat in.(mm)	Hexagon bolts Width of across flat in.(mm)	Tightening torque lbf·in.(N·m) [kgf·cm]
0.24 (6)	0.39(10)	44.2(5)[51]	0.20 (5)	0.39(10)	88.5(10)[100]
0.31 (8)	0.51(13)	106.2(12)[124]	0.24 (6)	0.51(13)	221.2(25)[245]
0.39(10)	0.67(17)	221.2(25)[245]	0.31 (8)	0.67(17)	433.6(49)[485]
0.47(12)	0.75(19)	380.5(43)[425]	0.39(10)	0.75(19)	752.2(85)[845]
0.55(14)	0.87(22)	601.8(68)[675]	0.47(12)	0.87(22)	1,194.7(135)[1,350]
0.63(16)	0.94(24)	938.1(106)[1,055]	0.55(14)	0.94(24)	1,858.4(210)[2,100]
0.71(18)	1.06(27)	1,283.2(145)[1,450]	0.55(14)	1.06(27)	2,566.4(290)[2,900]
0.79(20)	1.18(30)	1,814.2(205)[2,050]	0.67(17)	1.18(30)	3,628.3(410)[4,100]
0.87(22)	1.26(32)	2,477.9(280)[2,800]	0.67(17)	1.26(32)	4,955.8(560)[5,600]
0.94(24)	1.42(36)	3,053.1(345)[3,450]	0.75(19)	1.42(36)	6,283.2(710)[7,100]
Applied sections	For general sections such as bonnet and frame.		Compressor air-end, receiver tank and other designation part.		

IMPORTANT

- The above torque values in the table shall be applicable for the bolts and nuts used for machine.
- Generally, the abovementioned tightening torques should be followed, but in some points different torque is specified. So use the tightening torque without fail. (See following pages.)
- Make sure to remove rust and dust before tightening.

2. Maintenance

2.2.2 Tightening torque of such important quality parts as bolts and nuts

[Excerpted from HIS C-40940 (company standard)]

	Application parts & portions	Strength classification		Torque section	Tightening torque lbf·in.(N·m)[kgf·cm]												Remarks	
		Bolt	Nut		Coarse thread / fine thread													
					M6	M8	M10	M12	M14	M16	M18	M20	M22	M24				
1	Air-end																	
	① · End cover	10.9	—	4.8	44.2 (5) [51]	106.2 (12) [124]	—	380.5 (43) [425]	—	—	—	—	—	—	—	—	—	for prevention of deformation of outer ring
	② · Plate holding pinion gear	12.9	—	10.9	—	292.0 (33) [325]	566.4 (64) [640]	—	—	—	—	—	—	—	—	—	—	for prevention from loosening
	· Others	12.9	—	8.8	88.5 (10) [100]	221.2 (25) [245]	433.6 (49) [485]	752.2 (85) [845]	1194.7 (135) [1350]	1858.4 (210) [2100]	—	—	—	—	—	—	—	
2	Mounting																	
	③ · Mounting bracket	4.8	—	4.8	—	106.2 (12) [124]	221.2 (25) [245]	380.5 (43) [425]	601.8 (68) [675]	929.2 (105) [1050]	1327.4 (150) [1500]	1858.4 (210) [2100]	—	—	—	—	—	with spring washer
	④ · Vibration isolator ass'y	—	4.8	4.8	—	106.2 (12) [124]	221.2 (25) [245]	380.5 (43) [425]	601.8 (68) [675]	929.2 (105) [1050]	1327.4 (150) [1500]	1858.4 (210) [2100]	—	—	—	—	—	use spring washer and nut
3	Coupling portion between comp. air-end and engine																	
	⑤ · Housing	4.8	—	4.8	—	106.2 (12) [124]	221.2 (25) [245]	380.5 (43) [425]	601.8 (68) [675]	929.2 (105) [1050]	1327.4 (150) [1500]	1858.4 (210) [2100]	—	—	—	—	—	with spring washer
	⑥ · Coupling (for installing flywheel)	10.9/12.9	—	8.8	—	221.2 (25) [245]	433.6 (49) [485]	752.2 (85) [845]	1194.7 (135) [1350]	1858.4 (210) [2100]	2477.9 (280) [2800]	3628.3 (410) [4100]	—	—	—	—	—	with spring washer
	⑦ · Coupling (for installing driving shaft)	12.9	—	8.8	—	221.2 (25) [245]	433.6 (49) [485]	752.2 (85) [845]	1194.7 (135) [1350]	1858.4 (210) [2100]	2477.9 (280) [2800]	3628.3 (410) [4100]	—	—	—	—	—	with lock washer
4	Lifting portion																	
	⑧ · Lifting bail (less than M20)	10.9	4.8	6.8	—	159.3 (18) [183]	327.4 (37) [365]	601.8 (68) [675]	929.2 (105) [1050]	1327.4 (150) [1500]	1858.4 (210) [2100]	—	—	—	—	—	—	with spring washer
	· Lifting bail (more than M20)	10.9	4.8	4.8	—	—	—	—	—	—	—	1858.4 (210) [2100]	2477.9 (280) [2800]	3053.1 (345) [3450]	—	—	—	with spring washer
5	Pressure vessel and pipes																	
	⑨ · Separator cover	10.9	—	8.8	—	221.2 (25) [245]	433.6 (49) [485]	752.2 (85) [845]	1194.7 (135) [1350]	1858.4 (210) [2100]	2477.9 (280) [2800]	3628.3 (410) [4100]	4955.8 (560) [5600]	6283.2 (710) [7100]	—	—	—	with spring washer
	⑩ · Pressure control valve body	10.9	—	8.8	—	221.2 (25) [245]	433.6 (49) [485]	752.2 (85) [845]	1194.7 (135) [1350]	1858.4 (210) [2100]	2477.9 (280) [2800]	3628.3 (410) [4100]	4955.8 (560) [5600]	6283.2 (710) [7100]	—	—	—	with spring washer ※2
	⑪ · Pressure control valve cover	10.9	—	4.8	—	106.2 (12) [124]	221.2 (25) [245]	380.5 (43) [425]	601.8 (68) [675]	929.2 (105) [1050]	1327.4 (150) [1500]	1858.4 (210) [2100]	2477.9 (280) [2800]	3053.1 (345) [3450]	—	—	—	with spring washer
	⑫ · Flange for pipe	First priority	4.8	4.8	4.8	—	106.2 (12) [124]	221.2 (25) [245]	380.5 (43) [425]	601.8 (68) [675]	929.2 (105) [1050]	1327.4 (150) [1500]	1858.4 (210) [2100]	2477.9 (280) [2800]	3053.1 (345) [3450]	—	—	with spring washer
	⑬ · Flange for pipe (less than M20)	Second priority	10.9	8.8 ※3	8.8	—	221.2 (25) [245]	433.6 (49) [485]	752.2 (85) [845]	1194.7 (135) [1350]	1858.4 (210) [2100]	2566.4 (290) [2900]	—	—	—	—	—	with spring washer
	⑭ · Flange for pipe (more than M20) ※1	Second priority	10.9	4.8	4.8	—	—	—	—	—	—	—	1858.4 (210) [2100]	2477.9 (280) [2800]	3053.1 (345) [3450]	—	—	with spring washer
6	Undercarriage																	
	⑮ · Drawbar	10.9	4.8	6.8	—	—	—	—	—	—	—	—	3053.1 (345) [3450]	—	—	—	—	with spring washer

※1 For larger than M20, tightening torque becomes so big, and so 4.8 or equivalent shall be used.

※2 When fixing parts of aluminum are used, lock washer shall be used for avoiding damage.

※3 Nut shall be of S45C (equivalent to 8.8 of strength classification).

2. Maintenance

1 Air-end

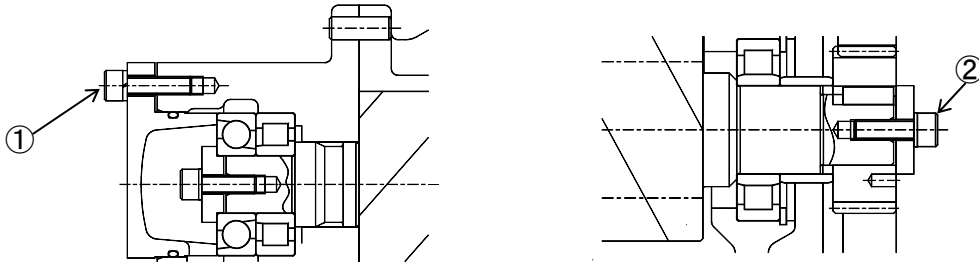

2 Mounting

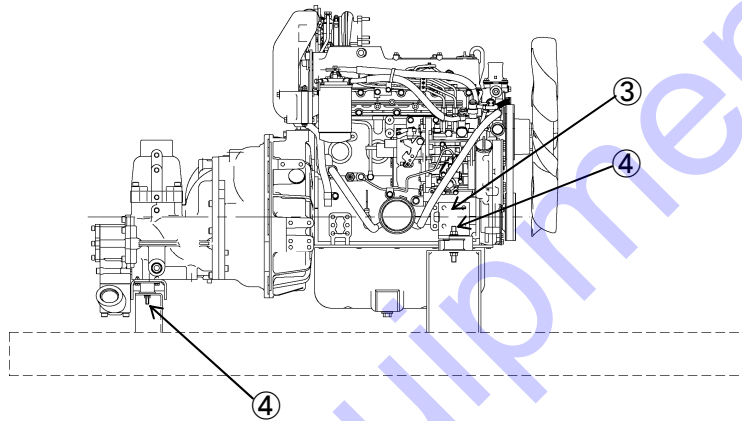

3 Coupling portion between comp. air-end and engine

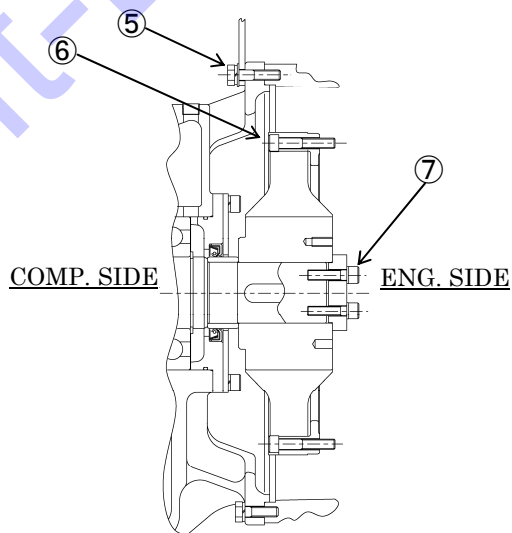

PC12076

2. Maintenance

4 Lifting portion

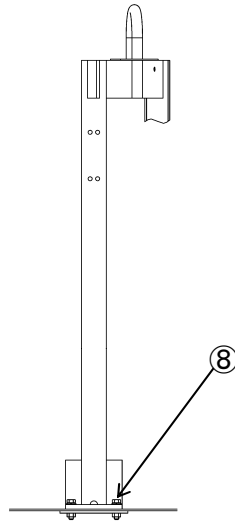

PC13054

5 Pressure vessel and pipes

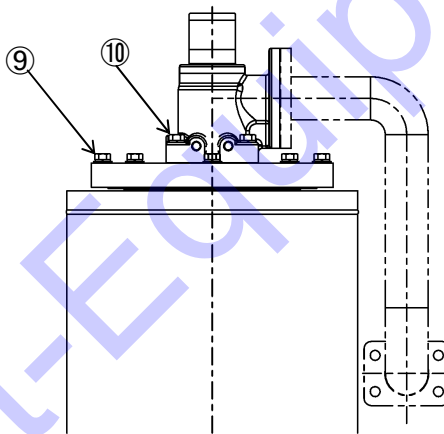

PC13055

6 Undercarriage

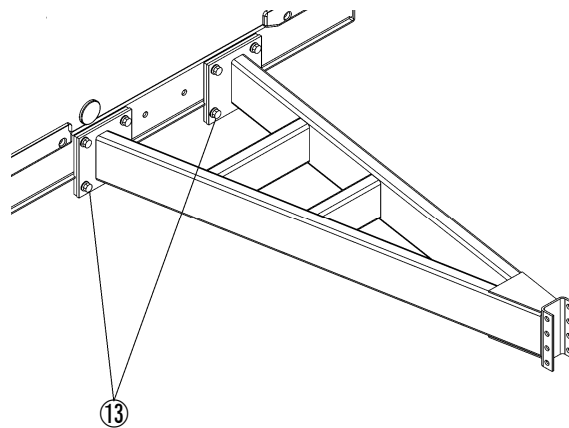

PC14065

2. Maintenance

2.3 How to Adjust Regulator

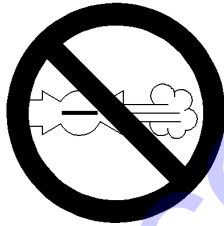
CAUTION 	<ul style="list-style-type: none">● When adjusting regulator system, install a silencer to the air delivery port and wear earplugs for protection of hearing damage. Operation with compressed air supply port opened is prohibited.	
D003		

- The speed regulator is already adjusted prior to delivery ex. works. Never change the setting of the regulator by turning bolt and rod recklessly.
- If it is necessary to re-adjust the speed regulator due to overhauling or any trouble, adjust it in accordance with the following procedures.

<How to adjust regulator>

- Adjust by loosening nut “1” and turning adjusting screw “2” .
- Adjust so that engine speed drops when pressure exceeds the unloader starting pressure 100psi (0.69MPa)[6.9bar].
- Make sure to retighten nut “1” after finishing adjustment.
Turning it to right, pressure increases, while turning it to left, it drops.

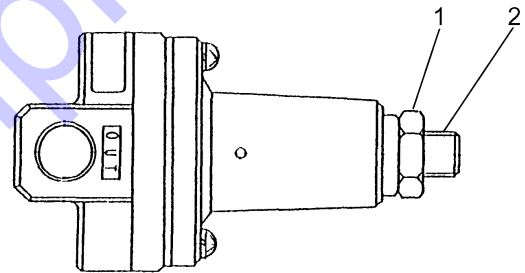

PC13056

- ※ Please refer to clause 3.2 for how to adjust engine speed.
- When it is impossible to adjust it, it could be due to the damage of diaphragm “3” . So replace the regulator and try it again.

Inner structure

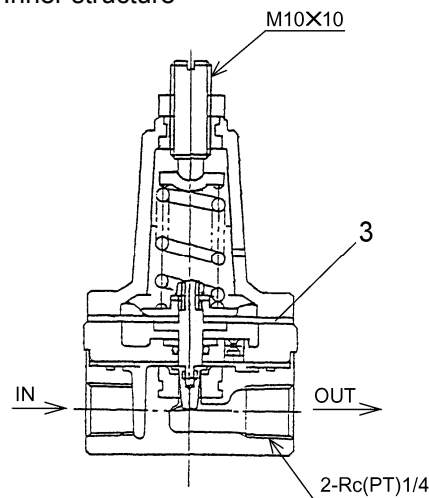

PC13057

2. Maintenance

2.4 Maintenance and Adjustment of Pressure Control Valve

(1) Procedure of maintenance

In case that the discharge air pressure becomes lower than 51psi (0.35MPa) [3.5bar], it is necessary to adjust the pressure of the pressure control valve according to the following procedures.

As it is possible that the O-ring has deteriorated or hardened, replace the O-ring even if the replacement cycle has not yet been reached.

<Procedure>

- ① Remove the pressure control valve cover "1" (opposite side 65mm), and remove spring seat "2" . Then change the spring "3" .
- ② After installing the spring seat "2" , assemble the cover "1" (opposite side 65mm).
- ③ After assembling, operate it to check and confirm that there is nothing abnormal.

Before assembling, coat the threaded portion (C portion) of spring seat "2" and of cover "1" with lithium based all-purpose grease for prevention of falling of spring seat and for prevention of thread galling.

 : 65 mm

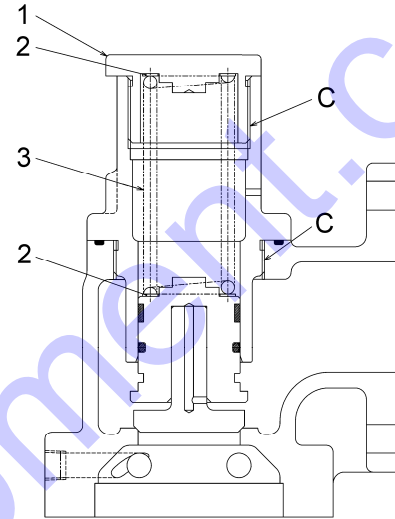

PC13058

< Inspection procedures of piston, valve, ring and O-ring >

When the pressure is low even after the spring is replaced, disassemble and inspect it, in the following procedures.

- ① After checking and confirming that compressed air is completely emptied, remove the cover "1" and then remove the spring "3" .
- ② After removing the cover "4" (opposite side 65mm), and piston "5" and valve "6" , check the ring "7" and O-ring "8" for any hardness and any damages. If piston "5" and valve "6" are found worn, replace them.
- ③ Coat the sliding surface (A portion) of valve "6" with compressor oil.
- ④ Coat the sliding surface (B portion) of piston "5" with grease.
- ⑤ Prevent the threaded portion (C portion) from galling by coating the threaded portion with grease.
- ⑥ Coat ring "7" and O-ring "8" with grease.
- ⑦ Coat both sides of spring seat "2" with grease so that it cannot fall when assembling.
- ⑧ Re-assemble the pressure control valve in reverse order to disassembly.
- ⑨ After having assembled, operate to check and confirm that the set pressure is 0.4+0.10/-0.05MPa.

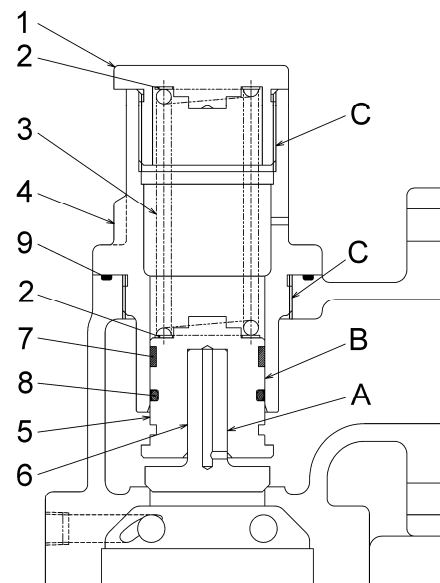

PC13059

2. Maintenance

WARNING



- When disassembling the pressure control valve, remove the cover “4” after removing the cover “1” first without fail. If the cover “4” should be removed with the cover “1” fitted, the cover “4” will jet out by the tensile strength of the inside spring, and it could cause a serious accident.

IMPORTANT

- When reassembling, apply thinly grease to O-ring and sliding surface. Use CALTEX MULTIFAK EP1 grease or equivalent. Grease of poor quality will deteriorate the material.

2. Maintenance

2.5 Change O-ring of Unloader

<Caution during O-ring replacement>

- Apply a thin coat of grease on the O-rings when replacing the O-rings “1” and “2” .
- ※ The piston “5” is threaded with an M5 tapping in the center area (A) to enable attachment of an eye bolt, etc. in order to pull out the piston “5” .
- Replace gasket “3” and “4” with new ones.
- After degreasing the contact face of gasket “3” and “4” , coat them with “THREEBOND 1212” and install them.
- When A face is disassembled, degrease it, and coat it with liquid sealing packing “LOCTITE No.5127” and assemble it.

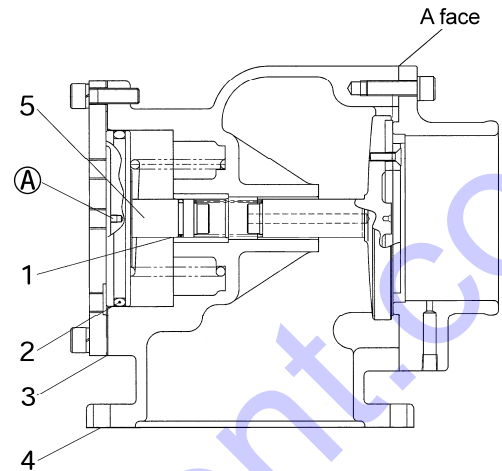

PC13060E

IMPORTANT

- When reassembling, apply thinly grease to O-ring and sliding surface. Use CALTEX MULTIFAK EP1 grease or equivalent. Grease of poor quality will deteriorate the material.

2.6 Change O-ring of Auto-relief Valve and Vacuum Relief Valve

- Disassemble and clean the component, and check O-ring “1” , “2” and “3” . Then, replace O-ring “1” , “2” and “3” , if hardened.

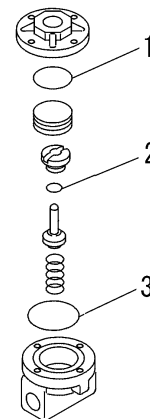

PC12064-1

IMPORTANT

- When reassembling, apply thinly grease to O-ring and sliding surface. Use CALTEX MULTIFAK EP1 grease or equivalent. Grease of poor quality will deteriorate the material.

2. Maintenance

2.7 Change Oil Separator

- When consumption of the oil is still unusual even after cleaning strainer in the scavenging orifice, change the oil separator with a new one.
- When replacing oil separator, be sure to replace gasket too.

<Procedure>

- ① In order to pull out the oil separator "1", unscrew the fixing bolts (M8, 4 pieces) for top cover inspection cover provided on top of separator cover.
 - ② Remove the bracket for fixing the solenoid valve on the separator cover "2" and also remove all the cables connected to the solenoid valve. Further, remove all the nylon tubes fixed on cable connecting parts.
 - ③ Remove the fixing bolts (M12, 4 pieces) provided at (A) flange of separator outlet.
 - ④ Remove the fixing bolts (M12, 8 pieces) of separator cover "2".
 - ⑤ Screw two lifting eyebolts (M12) for the 2 threaded holes provided on the separator cover "2".
 - ⑥ Pass a rope through the eyes of the lifting bolts and lift the separator cover "2" up by a crane etc. Mark the separator cover "2" and separator receiver tank "3" for reassembling them before removing it.
 - ⑦ Clean and degrease the connecting portion between separator cover "2" and separator receiver tank "3" and check and confirm that there are no damages nor abnormalities.
 - ⑧ Replace the oil separator "1", gasket "4", "5" and (A) flange of gasket (1 piece) by new ones.
 - ⑨ At the point where gasket "4" and "5" contact the oil separator, staple "6" is to be pinned in four points (diagonally) for prevention of static electricity. The staples "6" of gasket "4" and "5" should be stapled not being overlapped. ※HD-35 of MAX CO. LTD., should be used.
 - ⑩ Tighten the fixing bolts of separator cover "2" according to the specified torque.
(Tighten the bolts diagonally and after tightening all the bolts, ultimately tighten them again in full circumference.)
 - ⑪ Tighten the fixing bolts of (A) flange according to the specified torque.
 - ⑫ Connect re-assemble the pipes which were removed from the top of separator cover "2".
- ※ Gasket "4", "5" and gasket of (A) flange are to be coated with "THREEBOND 1212" at both faces and then to be tightened.

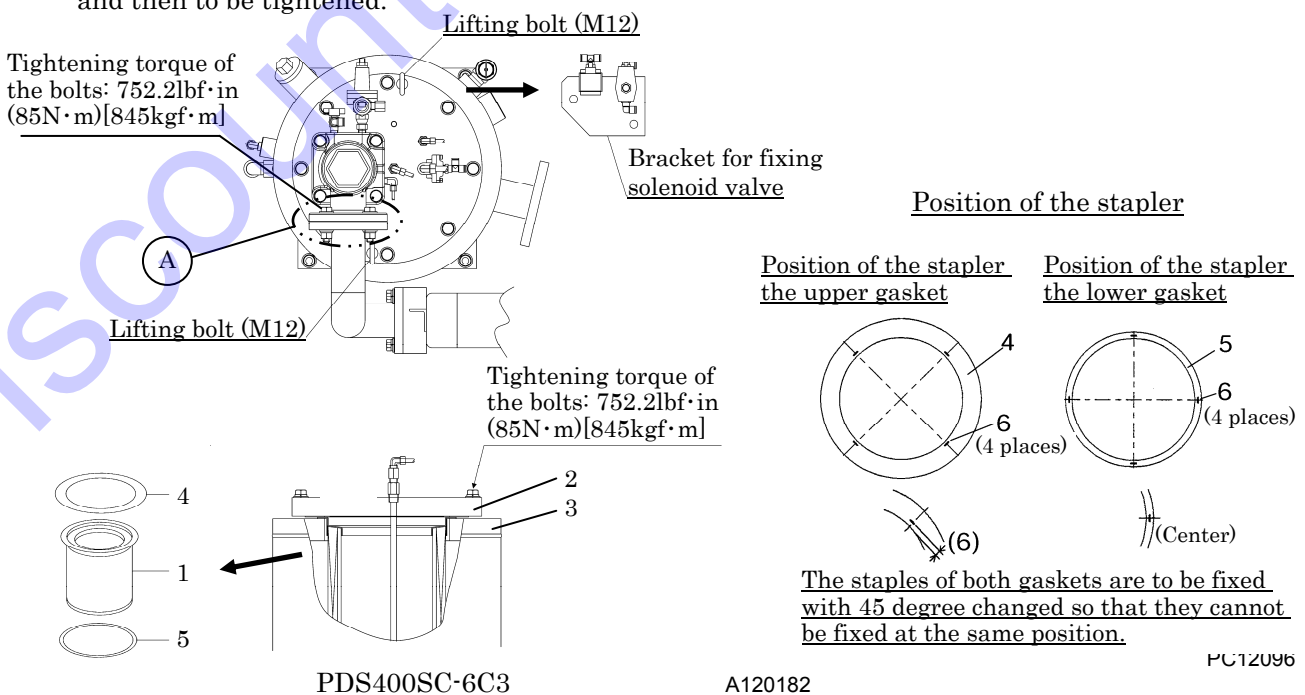

2. Maintenance

2.8 Change of Pellet assembly of By-pass Valve

- By-pass valve fitted on this unit is of full bore type. While the unit is used for normal operation, it is not to perform periodical replacement of the Inner pellet assembly, but when such trouble as excessive rise of compressor oil temperature, it becomes necessary to replace it, in accordance with the following procedures.

<Procedure>

- ① First stop the unit and make sure that there is no residual pressure left in the separator receiver tank.
- ② After checking and confirming that the temperature of compressor oil has become amply low, open drain valves on separator receiver tank and oil cooler to empty compressor oil completely.
- ③ After draining of compressor oil is finished, disassemble the by-pass valve by removing the bolt "1" and take out the pellet assembly "2" .
- ④ Replace the pellet assembly "2" and O-ring "3" by new ones.
※Install O-ring "3" coated thinly with compressor oil.
- ⑤ Supply compressor oil through the filler port provided on the receiver tank.
- ⑥ Start operation and check the function of by-pass valve.
(It functions well when delivery air temperature will not rise abnormally.)

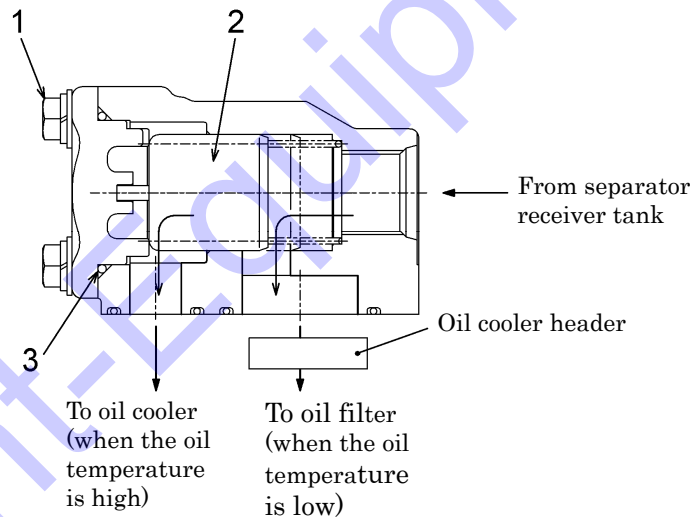

PC13061

Actuating temperature	※By-pass valve fully closing temperature
180±37°F (82±3°C)	192±36°F (89±2°C)

※ By-pass valve fully closing temperature:

Temperature at which the by-pass circuit is fully closed.

2. Maintenance

2.9 Clean the Strainer Provided inside the Engine Feed Pump

- To each 500Hr, remove the strainer “2” inside the joint bolt “1” fitted at the inlet side of the feed pump and clean it.
- Remove the strainer “2” by loosening the joint bolt “1” and clean it with diesel fuel oil, and also using high air pressure blow. At this time be sure to replace gasket “3” .
Then after finishing all cleaning jobs, install it again in reverse steps.

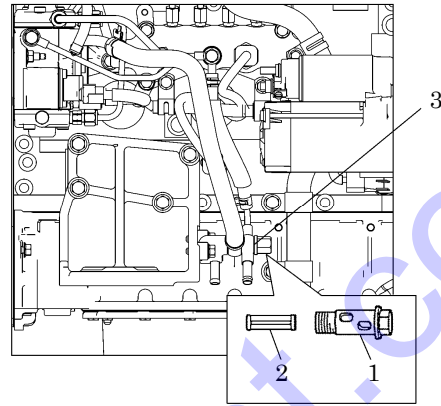

A120067

2.10 Supply Grease to Trailer Hub Bearing

- When replenishing grease to the trailer hub bearing, contact our office nearby or distributor.

Grease: Chassis grease

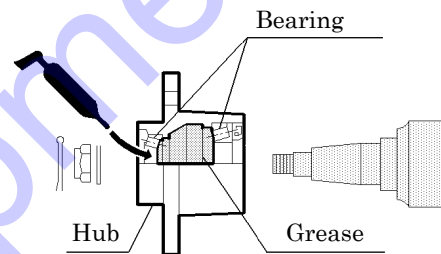

TR0260-1

2.11 Supply Grease to Leaf Spring Pin

- Supply grease through grease nipples positioned at the bottom.

Grease: Chassis grease

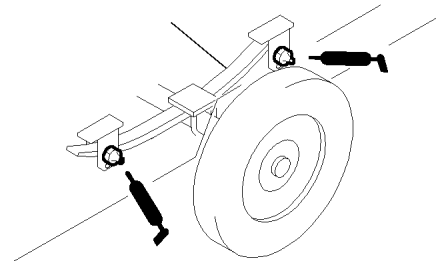

TR0260B

2.12 Check and Confirm that the Fixing Bolts for the Drawbar are Properly Tightened

- Check and confirm once every three months that the bolts with which drawbar is fixed are not loosened. (8 points)
- If it is found that specified tightening torque of clamped bolts drops to a lesser value, retighten them to correct specified value.

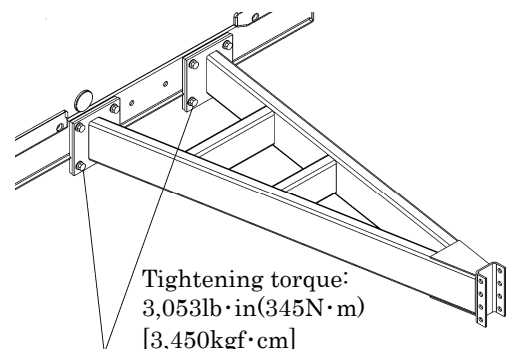

Tightening torque:
3,053lb·in(345N·m)
[3,450kgf·cm]

A120201

2. Maintenance

2.13 Manual Air Bleeding Method for Fuel Line System

<Procedure>

- ① Place starter switch to “RUN” position to keep electromagnet pump functioning.
- ② Loosen “Air-bleeding plug” enough to move “Priming pump” (more than 20 times) till fuel comes out.
- ③ Tighten “Air-bleeding plug” and move “Priming pump” (more than 10 times) till fuel is filled in fuel filter.
- ④ After waiting about 1 minute, loosen “Air-bleeding plug” to bleed air from air filter.
- ⑤ Repeat the above procedures ②-④ till air does not come out from “Air-bleeding plug”. (at least more often than 3 times).
- ⑥ Tighten “Air-bleeding plug” for sure and wipe out fuel around, check that there is no fuel leakage to start the engine.

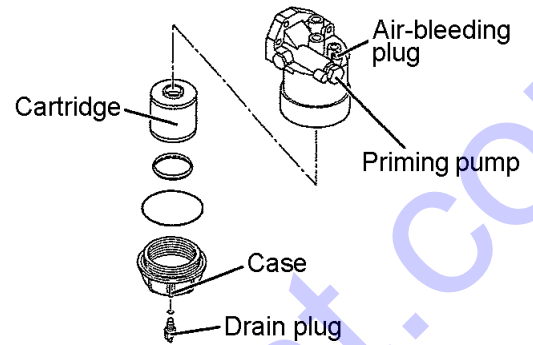

A090118E

2.14 Clean inside of Fuel Tank

- Condensate is caused and accumulated at the bottom of fuel tank, owing to churning of dust or dirt mixed when fuel oil is fed and water drop caused while fuel oil tank is used for a long time. When any condensate is found afloat and fuel filter gets clogged too fast, fuel oil tank should be cleaned after condensate is removed from fuel oil tank even before the specified cleaning interval time.

<Procedure>

- ① Open drain valve to remove fuel oil from fuel tank.
- ② Remove the fender on the right side to open the door of the bonnet.
- ③ Remove fuel pipes and wires connected to fuel tank.
- ④ Remove belt holding fuel tank and remove tank.
- ⑤ Insert cleansing nozzle through fuel filler port or drain port for cleaning tank.
- ⑥ After cleaning job is finished, install fuel tank from which water or the like should be completely removed.

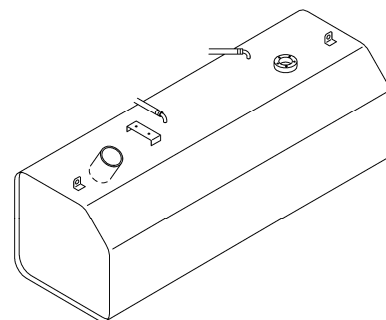

PC13062

2. Maintenance

2.15 Clean Drain Separator (Aftercooler type only)

- Due to accumulation of dust, dirt and sludge etc., the outlet of condensate could be clogged so that condensate cannot be drained. And in case that the service air is mixed with water, clean the drain separator.

<Procedure>

- ① Remove the ball "1" by turning it.
- ② Check the outlet "2" whether it is clogged and clean it.
- ③ As it is possible that the O-ring "3" has deteriorated or hardened, replace the O-ring.
- ④ After finishing clean, assemble it in reverse procedure.

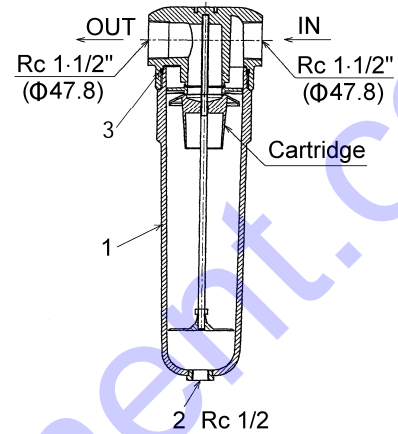

PC13063E

2.16 Values of Various Adjustments of Engine

Item		Unit	PDS400S-6C3	
Engine model			ISUZU CI-4JJ1XYCD-01 ISUZU CI-4JJ1XYCD-01G	
Tightening torque of head bolts		lbf·in. (N·m) [kgf·cm]	M11 bolt	
			First stage	620(70)[7.1]
			Second stage	620(70)[7.1]
			Third stage	60° (angle tightening)
			Fourth stage	60° (angle tightening)
Valve clearance	Air intake	in.(mm)	0.006(0.15) (in cold season)	
	Discharge	in.(mm)	0.006(0.15) (in cold season)	
Firing order			1-3-4-2	
Injection timing (BTDC)		°	Electronic control unit	
Nozzle injection pressure		psi(MPa)[bar]	—	
Compression	Standard	psi(MPa)[bar]	442(3.04)[30.4] (Rotation speed 200min ⁻¹)	
	Working limit	psi(MPa)[bar]	Limited value	285(1.96)[19.6]
			Each cylinder limit value	42(0.29)[2.9]
Thermostat	Temperature for start of release	°F(°C)	185 (85)	
	Full open temperature	°F(°C)	212(100)	
	Valve lift	in.(mm)	0.4 (10)	

※For the details, refer to engine manufacturer's workshop manual.

2. Maintenance

2.17 Suction Control Valve (SCV) Replacement Procedure

[Excerpted from ISUZU troubleshooting manual]

The suction control valve (SCV) is installed onto supply pump section of engine and controls pressure feed of fuel (discharge amount) to common rail.

Refer to “3.18 Electronic Control Engine Component” for details.

Note:

The illustration indicates the supply pump unit only in order to explain easily.

- ① Disconnect the suction control valve (SCV) connector.

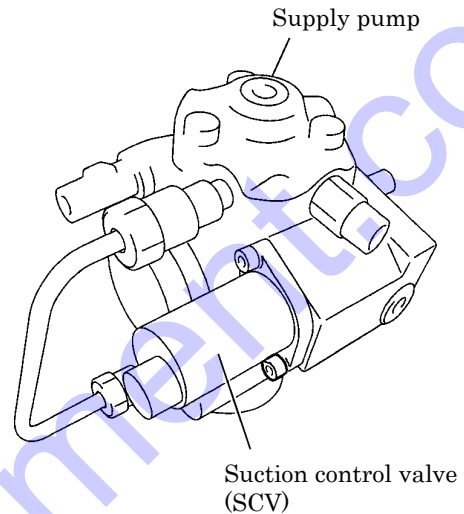

SG09043

- ② Wash the outside of the suction control valve (SCV) using a cleaning spray.

Note:

- Wash the suction control valve (SCV) to remove dust or foreign matter in the pump housing or on the installation surface when replacing it.
- Do not allow cleaning solvent of the spray to enter inside of the suction control valve (SCV) connector.

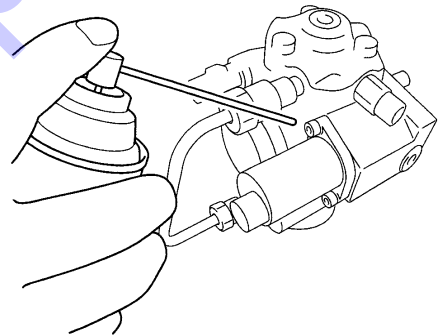

SG09044

- ③ Remove the two bolts which tighten the suction control valve (SCV).

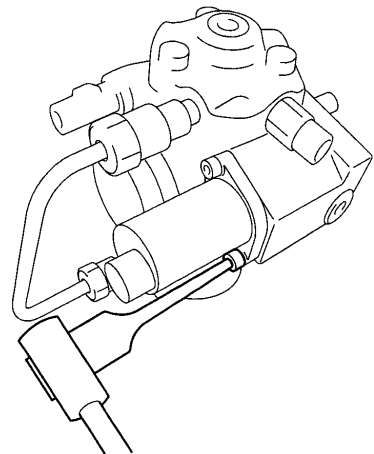

SG09045

2. Maintenance

- ④ Pull out the suction control valve (SCV).

Note:

- If it is hard to pull it out due to the resistance on the O-ring, pull it out while rotating it from side to side.
- To prevent foreign matter from entering, do not put gloves on from the next work.

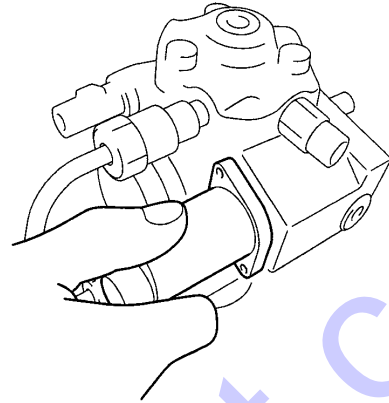

SG09046

- ⑤ Remove the O-ring of the suction control valve (SCV).

Note:

Be careful not to let foreign matter enter the pump housing at removal.

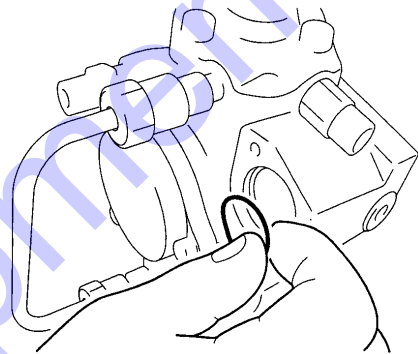

SG09047

- ⑥ Check the replacement part.

Note:

Make sure that you have got all parts indicated in the illustration.

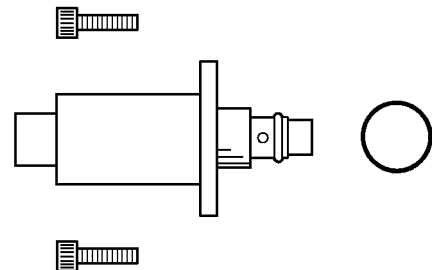

SG09048

- ⑦ Place the new O-ring in the O-ring groove.

Note:

- Do not touch the O-ring with dirty hands.
- Perform this work after making sure there is no foreign matter in the O-ring groove.

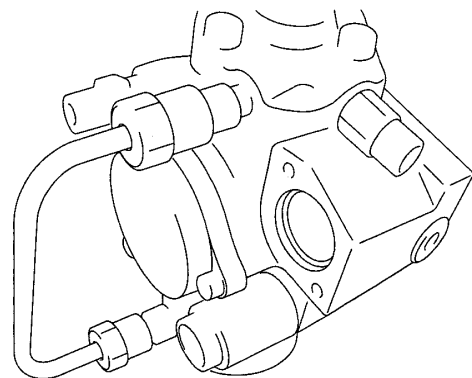

SG09049

2. Maintenance

- ⑧ After placing the O-ring, apply oil to it.

Note:

- Use clean oil such as new engine oil.
- Do not let foreign matter on the O-ring.

- ⑨ Insert the suction control valve (SCV) into the pump housing.

Note:

Insert the suction control valve (SCV) by hand until it contacts the housing.

If it is hard to insert the suction control valve (SCV), insert it while rotating it from side to side slightly.

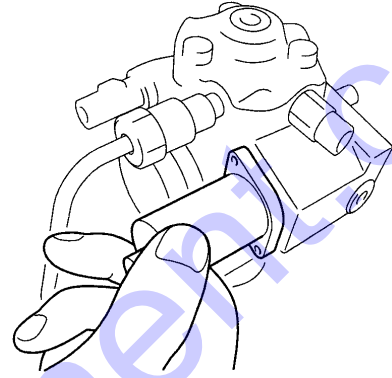

SG09050

- ⑩ Temporarily tighten the two suction control valve (SCV) installing bolts.

Note:

Temporarily tighten the two bolts evenly by hand until the suction control valve (SCV) contacts the pump housing completely.

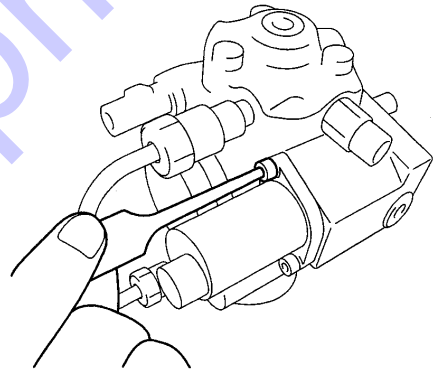

SG09052

- ⑪ Fully tighten the suction control valve (SCV) installing bolts to the specified torque.

 : 61 to 96lb·in (6.9 to 10.8N·m) [70 to 110kgf·cm]

Note:

After tightening the two bolts, tighten again the bolt tightened firstly.

- ⑫ Connect the suction control valve (SCV) connector.

- ⑬ Wipe off the fuel which was leaked at replacement work.

- ⑭ Start the engine, and make sure there is no fuel leaked from the installation part of the suction control valve (SCV).

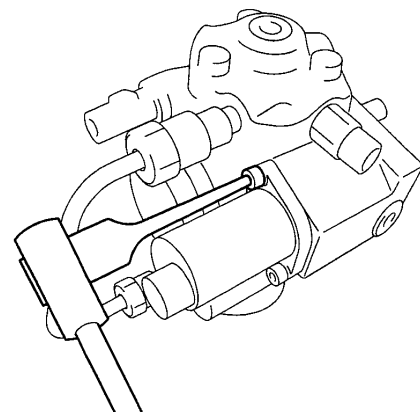

SG09053

3. Electric System

3.1 Electronic Control System of Engine

[Excerpted from ISUZU troubleshooting manual]

The engine control system is electronic control system which maintains optimum combustion status of engine all the time according to operating conditions. It consists of the following components.

- ① Electronic control fuel injection system (Common rail type)
- ② EGR (Exhaust gas recirculation) control
- ③ Acceleration control

The engine control system also has the following system control functions other than engine control.

- ④ QOS (Quick On Start) system
- ⑤ Engine speed signal output
- ⑥ Self-diagnosis function
- ⑦ CAN (Controller Area Network) communication (SAEJ1939/21, SAEJ1939/11)

3.1.1 Electronic control fuel injection system (Common rail type)

ECM (engine control module) detects such information as engine RPM, engine load etc (signals from various sensors). Base on the information, ECM sends electrical signal to supply pump and injectors to properly control fuel injection of each cylinder and injection time in this system.

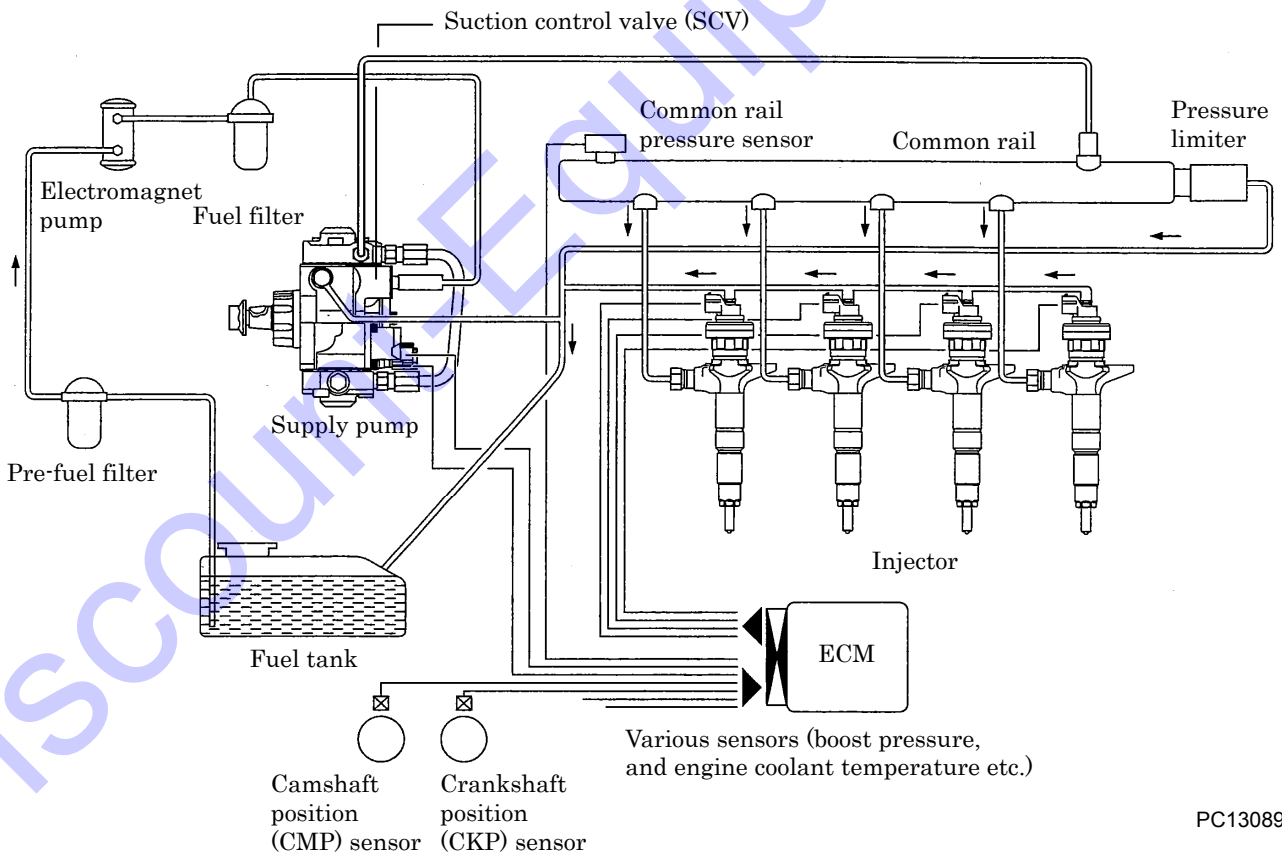

(1) Fuel system

Fuel is supplied to supply pump from fuel tank and then sent to common rail after it is pressurized by pressure pump. At the time fuel volume supplied to common rail is controlled by suction control valve (SCV).

3. Electric System

(2) Injection pressure control

Injection pressure is controlled by controlling the fuel pressure in the common rail. The appropriate pressure in the common rail is calculated based on the engine revolution speed and fuel injected amount, and proper fuel amount is injected by the control of the supply pump and it is sent to the common rail with pressure and being controlled.

(3) Injection time control

This control is conducted by calculation of fuel injection timing mainly based on engine revolution speed and injection amount as a substitute of timer and control of injectors.

(4) Injection rate control

In order to improve combustion in cylinders, at first a little fuel is injected (pre-injection) to ignite, and then once ignited, fuel is injected 2nd time (main injection). Control of injection timing and injection volume is performed by controlling injectors.

(5) Maximum fuel injection amount

This is calculated by adjustment of initial starting injection amount in accordance with water temperature and limitation of this maximum injection amount by boost pressure, and also control of fuel injection amount at high altitude by barometric pressure.

(6) Inter-cylinder correction

This is not used for this model.

3. Electric System

3.1.2 EGR (Exhaust gas recirculation) control

EGR is a exhaust gas recirculation system. Part of the exhausted gas is mixed again together with intake air to control oxygen density in combustion chamber in order to soften combustion and to lower combustion temperature. Thus, nitrogen oxides “NOX” can be reduced. Such device in which cooling device is equipped is called as cooled EGR system.

High temperature EGR gas exhausted is cooled through cooler and the cooled gas is mixed and cooled. Thus combustion gas temperature is cooled and NOX reduction is fulfilled more effectively than usual EGR gas.

Further, cooled intake air density increases and accordingly intake air increases.

Thus, combustion becomes perfect and it causes fuel consumption increase and PM black smoke reduction.

EGR function

ECM is to operate EGR motor according to such engine conditions as engine RPM, and engine load, and to control EGR valve lift. Valve lift is detected by EGR position sensor.

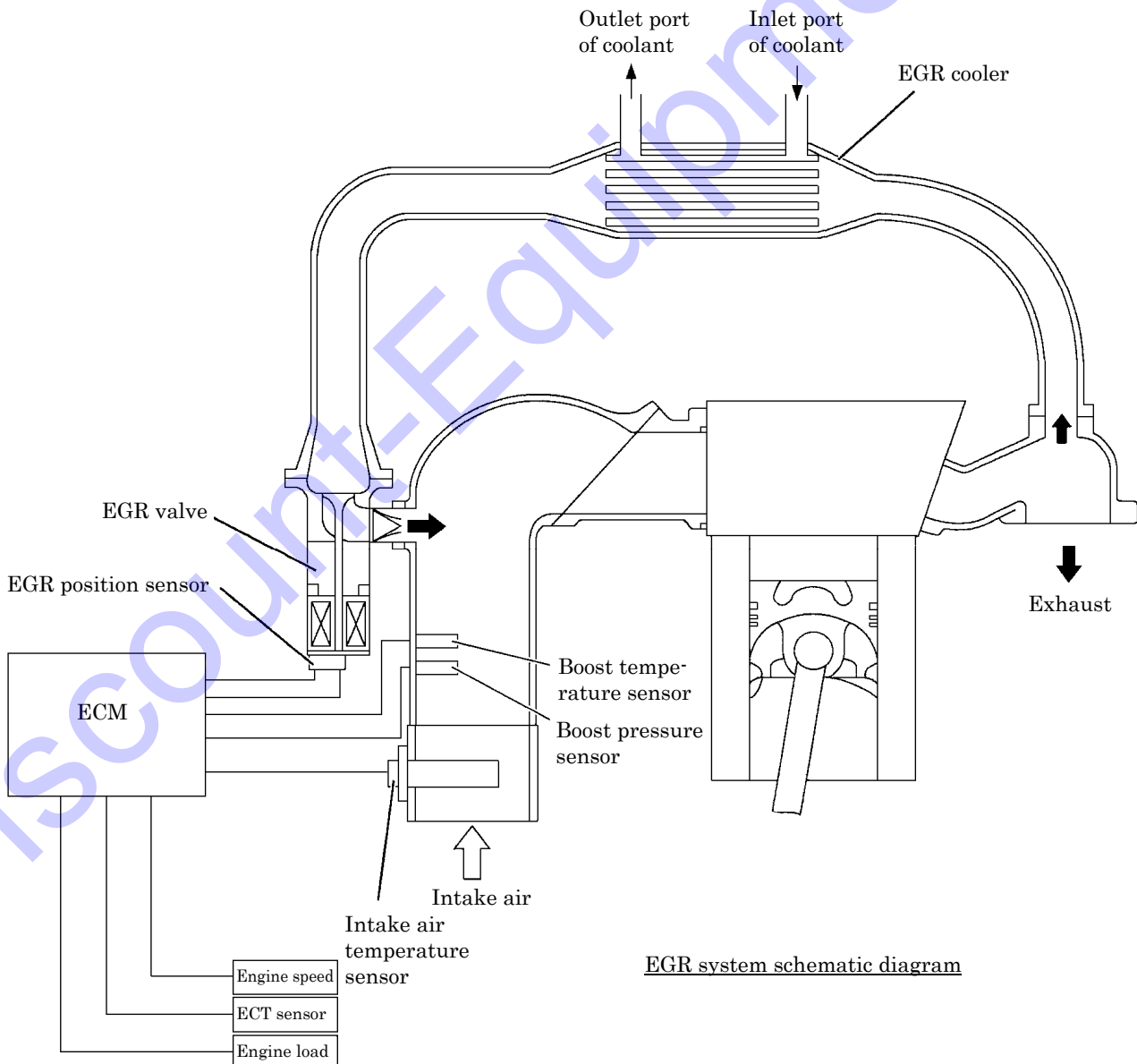

3. Electric System

3.1.3 Acceleration control

Accelerator controller (control of output and engine speed) receives electric signal outputted from pressure sensor, and it controls electronic fuel injection system by outputting to engine controller (ECM).

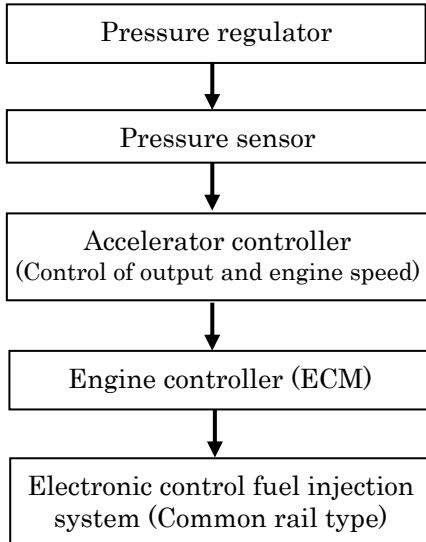

The pressures at 2nd stage is converted into voltage and outputted.

The inputted voltage (pressure signal) is converted into voltage again, and it outputs to engine controller (ECM)

The voltage inputted is converted to control signal and outputted.

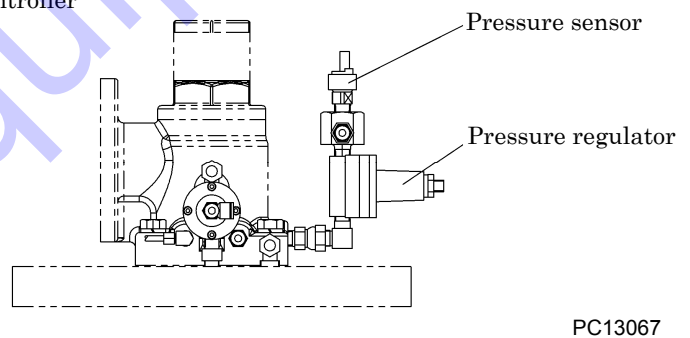
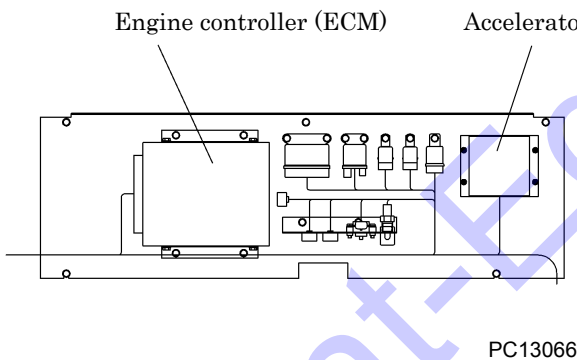

3.1.4 Preheating control

QOS (Quick On Start) system

The ECM determines the period required for glow (pre-glow, glow, after-glow), and operates the glow relay and QOS indicator lamp. QOS system allows to make the starting at cold weather easier and reduce white smoke and noise at starting. When turning the key switch to ON, the ECM detects the engine coolant temperature by signal from engine coolant temperature (ECT) sensor and changes the period for glow so that the proper starting conditions can be achieved all the time. Also, after-glow function allows to stabilize idling immediately after starting.

3. Electric System

3.2 Accelerator Controller

Part number:46870 54900

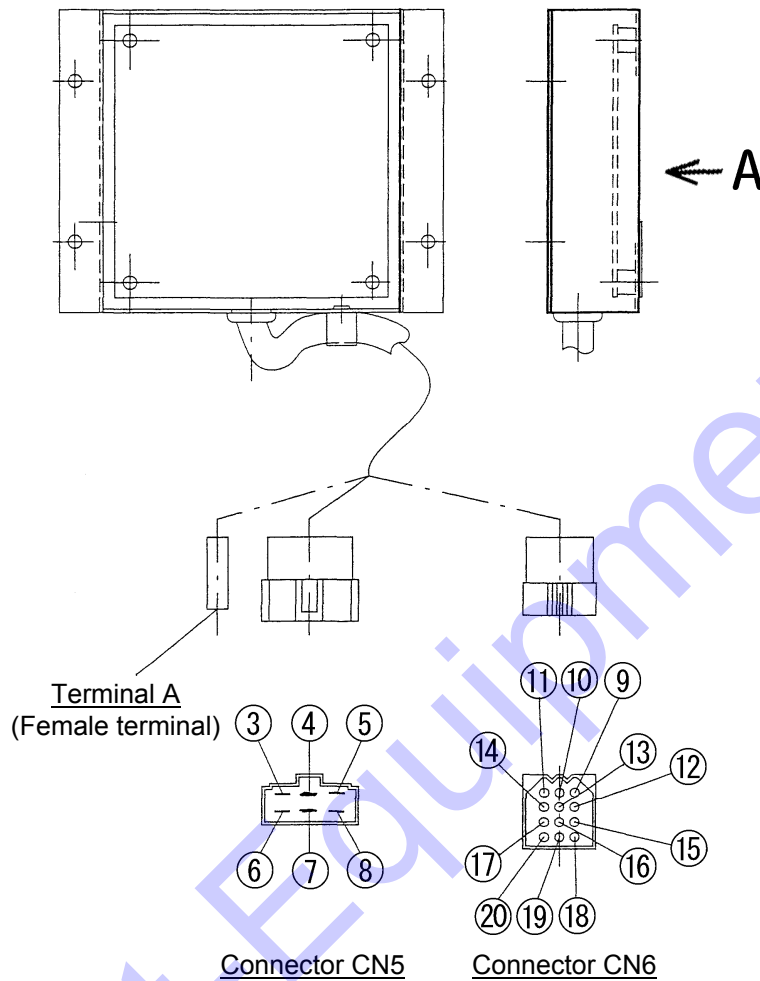

PC120013-1

- With replacement of the acceleration controller, if engine speed is found different from specified speed, perform following adjustment.

How to adjust engine speed

1. Adjust engine speed by turning full load speed adjusting screw.
Turning the adjusting screw to the right, the speed increases, and turning to the left it decreases.
2. Adjust engine speed at unloaded conditions.
※It is not necessary to adjust the central screw. After the adjustment of engine speed is finished, affix to the threaded portion a plate attached with accelerator controller as an accessory.

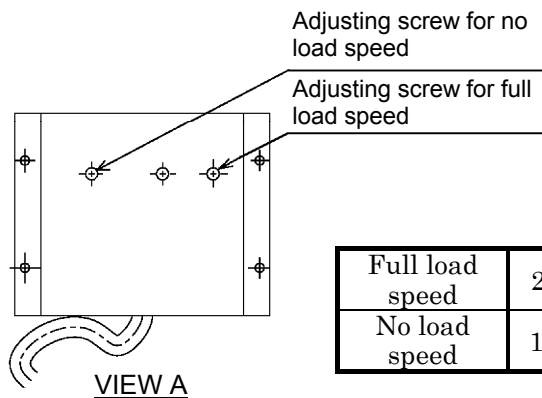

	(min ⁻¹)
Full load speed	2,200 ± 50
No load speed	1,300 -0

[Plate]

PARTS NO.	
SETTING SPEED	min ⁻¹
MANUFACTURE NO.	

PC12037-1

3. Electric System

1. List of functions (Connector CN6)

Pin Name	Line color	Connection	Function	
Connector	CN6-9	R	Engine controller (ECM) No.42 terminal	Power supply (DC5V) for accelerator sensor.
	CN6-10	W	Engine controller (ECM) No.63 terminal	Based on the input voltage of CN6-16 terminal, change the resistance between CN6-10 and CN6-11 and then output it to engine controller. (According to the pressure of regulator secondary side, adjust the opening and closing degree of engine accelerator.)
	CN6-11	B	Engine controller (ECM) No.41 terminal	Grounding
	CN6-12	—	NIL	—
	CN6-13	—	NIL	—
	CN6-14	—	NIL	—
	CN6-15	Y/R	Pressure sensor No.1 terminal	Power supply (DC5V) for pressure sensor.
	CN6-16	Y/W	Pressure sensor No.2 terminal	Pressure at 2nd stage regulator is detected. (DC voltage is inputted, in accordance with regulator 2nd stage pressure.)
	CN6-17	Y/G	Pressure sensor No.3 terminal	Grounding
	CN6-18	W/R	Emergency controller No.8 terminal	Circuit for sending two kinds of unload speed directives to engine controller (ECM). ● 140°F(60°C) less than the discharge air temperature 1,600min ⁻¹ ● 140°F(60°C) higher than the discharge air temperature 1,300min ⁻¹
	CN6-19	—	NIL	—
CN6-20	—	NIL	—	

2. List of functions (Terminal A, Connector CN5)

Pin Name	Line color	Connection	Function	
Terminal	A (Female terminal)	—	NIL	—
Connector	CN5-3	R/W	10A fuse	Power supply
	CN5-4	—	NIL	—
	CN5-5	—	NIL	—
	CN5-6	B	Grounding	—
	CN5-7	—	NIL	—
	CN5-8	—	NIL	—

3. Electric System

● Pressure sensor / Accelerator controller Output – revolution speed list (for reference only)

The voltage values in the following table are standard reference ones. They are different a little from actual ones during operation.

Output voltage of pressure sensor

Pressure sensor	
Regulator 2nd stage pressure psi(MPa)[bar]	Output voltage (DCV)
0.0	0.5
14.6(0.1)[1]	0.9
29.1(0.2)[2]	1.3
43.7(0.3)[3]	1.7
58.2(0.4)[4]	2.1
72.8(0.5)[5]	2.5
87.3(0.6)[6]	2.9

Voltage outputted from accelerator controller to engine controller (ECM)

Accelerator controller (Control of output and engine speed)		
Accelerator (%)	Output voltage (DCV)	Engine RPM (min^{-1})
0	1.00	1,300
25	1.75	1,525
50	2.50	1,750
75	3.25	1,975
100	4.00	2,200

3. Electric System

3.3 Engine Controller (ECM)

Part number:44390 03700

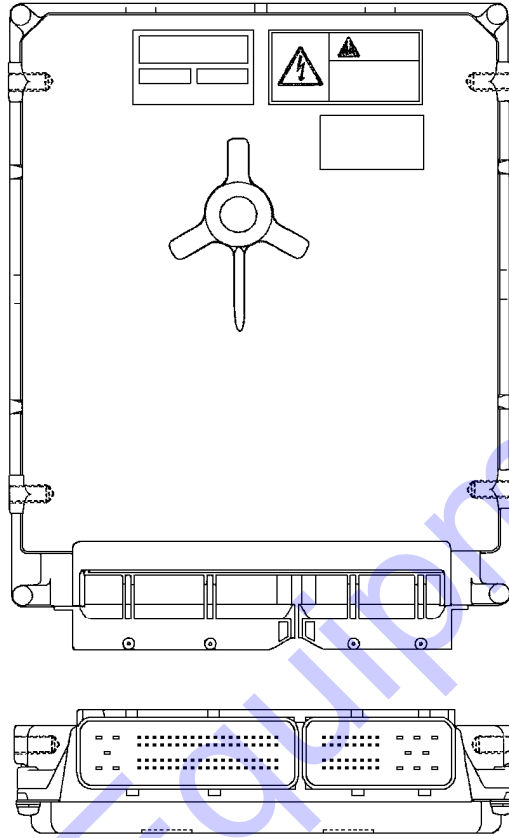

CN3 terminal [81 pins]

CN4 terminal [40 pins]

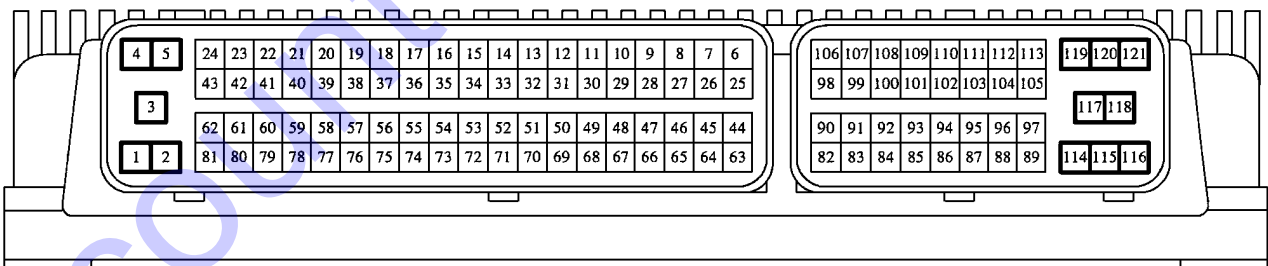

SG09037

3. Electric System

(1) General wiring diagram of engine controller (ECM)

- Some sensors are not connected to ECM depending on each model having its special specifications.
- Some sensors have input-output to ECM by signal of CAN communication. For the details, see engine wiring diagram of actual unit.

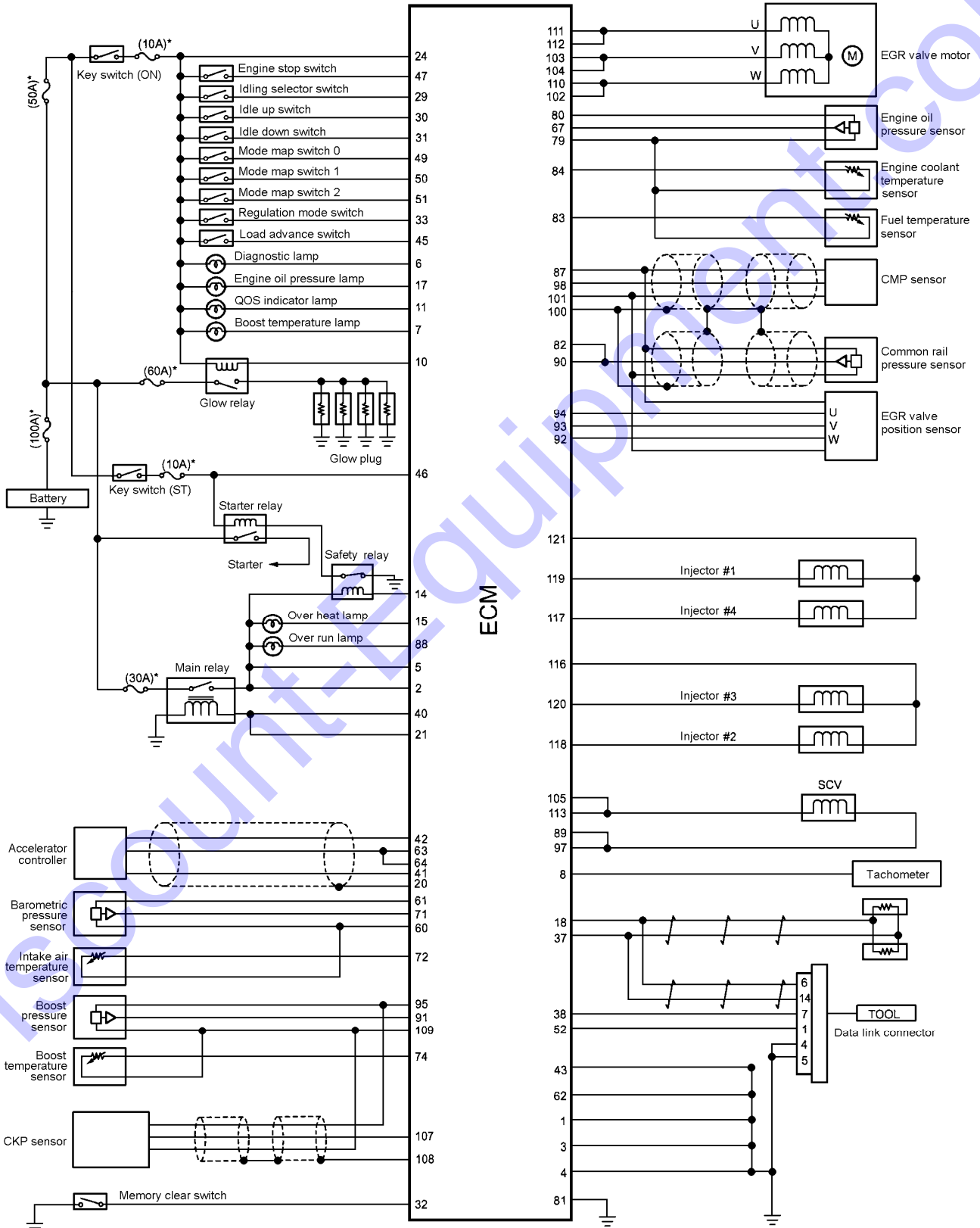

3. Electric System

(2) List of CN3 terminal function (81 pins)

Pin No.	Line color	Connection	Function
CN3-1	B	Grounding	
CN3-2	R/G	Main relay (MR)	Power supply
CN3-3	B	Grounding	
CN3-4	B	Grounding	
CN3-5	R/G	Main relay (MR)	Power supply
CN3-6	L/B	Diagnosis lamp	No power exists during usual operation. When engine trouble, interior contact in engine controller (ECM) is "ON", and it connects ground to sends power. Thus diagnosis lamp glows. At the time, it makes engine stop once, and when the starter switch is placed to "ON" again, and push diagnosis switch to send electricity to CN3-52 terminal, the lamp begins to flicker and this shows engine trouble at present and past.
CN3-7	W/Y	Emergency controller CN2-13 terminal (Boost temperature rise warning)	No power exists during usual operation. When boost temperature rises higher than set temperature, the interior contact in engine controller (ECM) becomes "ON" and it is connected to ground to send electricity to emergency controller. ● Boost temperature warning set temperature : 185°F (85°C)
CN3-8	Y/R	Emergency controller CN2-8 terminal	It outputs engine speed. ● Revolution ratio (pulse type) : 4 pulses per 1 revolution
CN3-9	—	NIL	
CN3-10	B/G	Glow relay (GR)	No power exists during usual operation. When power is sent to CN3-24 terminal, preheating starts. When preheating, interior contact in ECM is "ON", and it connects ground to sends power Thus glow relay (GR) works to preheat. ECM decides glow timing (pre-glow, glow and after-glow), according to engine coolant temperature and it sends power to CM3-10 terminal each time to function glow relay (GR).
CN3-11	L	Emergency controller CN2-12 terminal (Glow lamp)	No power exists during usual operation. When preheating, interior contact in ECM is "ON", and it connects ground to sends power. Thus preheating lamp glows.
CN3-12	—	NIL	
CN3-13	—	NIL	
CN3-14	B/W	Safety relay (SR)	When starter switch is located at "ON" position, the interior contact in ECM is "OFF". When it is located on "START" position, engine speed rises and when it becomes higher than 750min ⁻¹ , the interior contact in ECM becomes "ON" and it makes safety relay (SR) interior contact "OFF". Thus starter relay contact electricity is cut. (Safety relay is used for B contact.)

3. Electric System

Pin No.	Line color	Connection	Function
CN3-15	Y/L	Emergency controller CN2-14 terminal (Engine coolant temperature rise emergency stop)	No power exists during usual operation. When engine cooling water temperature rises to emergency stop set temperature, the interior contact in ECM becomes "ON" and connected to ground to send electricity to emergency controller. ●Emergency stop coolant temperature set temperature : 221°F (105°C)
CN3-16	—	NIL	
CN3-17	G/R	Emergency controller CN2-3 terminal (Engine oil pressure drop emergency stop)	No power exists during usual operation. When engine oil pressure drops to emergency stop set pressure, the interior contact in ECM becomes "ON" and connected to ground to send electricity to emergency controller. ●Emergency stop engine oil pressure set Pressure : Lower than 14.6psi(0.1MPa)[1.0bar]
CN3-18	B/W	Diagnosis tool No.6 terminal	Diagnosis tool connection terminal (CAN communication) With connection of diagnosis tool, it is possible to diagnose engine control system and to check system.
CN3-19	—	NIL	
CN3-20	B/W	Accelerator sensor shield	Noise prevention
CN3-21	Y/R	Main relay (MR)	When power is sent to CN3-24 terminal, it works main relay (MR). Thus main relay (MR) is switched and when power is supplied to CN3-2 and CN3-5 terminal, voltage is applied to electromagnet pump relay (FR) to operate the pump.
CN3-22	—	NIL	
CN3-23	—	NIL	
CN3-24	R/W	10A fuse	Switch "ON" starter switch to input (ACC) signal. Preheating starts.
CN3-25	—	NIL	
CN3-26	—	NIL	
CN3-27	—	NIL	
CN3-28	—	NIL	
CN3-29	—	NIL	
CN3-30	—	NIL	
CN3-31	—	NIL	
CN3-32	G	Memory clear terminal (Female terminal)	Ground connection of memory clear terminal resets past trouble memory. For use of this memory, please refer to "4.6.2 How to delete diagnostic trouble code (DTC)".
CN3-33	—	NIL	
CN3-34	—	NIL	
CN3-35	—	NIL	
CN3-36	—	NIL	

3. Electric System

Pin No.	Line color	Connection	Function
CN3-37	W/B	Diagnosis tool No.14 terminal	Diagnosis tool connection terminal (CAN communication) With connection of diagnosis tool, it is possible to diagnose engine control system and to check system.
CN3-38	W/G	Diagnosis tool No.7 terminal	
CN3-39	—	NIL	
CN3-40	Y/R	Main relay (MR)	When power is sent to CN3-24 terminal, it works main relay (MR). Thus main relay (MR) is switched and when power is supplied to CN3-2 and CN3-5 terminal, voltage is applied to electromagnet pump relay (FR) to operate the pump.
CN3-41	B	Accelerator controller CN6-11 terminal	Grounding
CN3-42	R	Accelerator controller CN6-9 terminal	Power supply for accelerator controller.
CN3-43	B	Grounding	
CN3-44	—	NIL	
CN3-45	—	NIL	
CN3-46	R/L	Starter switch C terminal	Inputting start signal.
CN3-47	G/L	Emergency controller CN1-3 terminal	External input terminal for engine emergency stop. When the interior contact (RY3) of emergency controller becomes “ON”, all emergency stop signals are sent to ECM to bring engine to emergency stop.
CN3-48	—	NIL	
CN3-49	—	NIL	
CN3-50	—	NIL	
CN3-51	L/W	Emergency controller CN1-7 terminal	Engine speed signal terminal. When the interior contact (RY2) of emergency controller becomes “ON”, a signal is sent to ECM from CN1-7 terminal to control starting unloader speed to 1,600min ⁻¹ .
CN3-52	Y/B	Diagnosis tool No.1 terminal Diagnosis switch	When engine stops with starter switch “ON”, and diagnosis lamp is “ON”, make diagnosis switch “ON”. Then diagnosis lamp begins to blink. Blinking pattern shows present and past engine troubles. The transmission failure information is also in fault diagnosis tool.
CN3-53	—	NIL	
CN3-54	—	NIL	
CN3-55	—	NIL	
CN3-56	—	NIL	
CN3-57	—	NIL	
CN3-58	—	NIL	
CN3-59	—	NIL	
CN3-60	L/B	Barometric pressure sensor SG terminal Intake air temperature sensor	Grounding

3. Electric System

Pin No.	Line color	Connection	Function
CN3-61	R/G	Barometric pressure sensor VCC terminal	Power supply (DC5V) for barometric pressure sensor.
CN3-62	B	Grounding	
CN3-63	W	Accelerator controller CN6-10 terminal	It controls regulator 2nd stage pressure voltage conversion value and engine speed is controlled between full load and unload revolution speed.
CN3-64	W	Accelerator controller CN6-10 terminal	
CN3-65	—	NIL	
CN3-66	—	NIL	
CN3-67	L/Y	Engine oil pressure sensor OUT terminal	It detects engine oil pressure. Pressure detecting voltage signal is high, when pressure is high, and it is low, when pressure is low.
CN3-68	—	NIL	
CN3-69	—	NIL	
CN3-70	—	NIL	
CN3-71	G/B	Barometric pressure sensor OUT terminal	It detects barometric pressure. It counts barometric pressure from voltage signal, and it corrects fuel injection volume (high altitude compensation).
CN3-72	L/R	Intake air temperature sensor	It detects intake air temperature of unit under operation. In order to optimize fuel injection control with ECM, it detects intake air temperature at unit in use (In front of engine air intake device).
CN3-73	—	NIL	
CN3-74	B/R	Boost temperature sensor	It detects intake air temperature in intake manifold.
CN3-75	—	NIL	
CN3-76	—	NIL	
CN3-77	—	NIL	
CN3-78	—	NIL	
CN3-79	B/Y	Engine oil pressure sensor GND terminal Engine coolant temperature sensor Fuel temperature sensor	Grounding
CN3-80	W/B	Engine oil pressure sensor VCC terminal	Power supply (DC5V) for engine oil pressure sensor.
CN3-81	B	Grounding	

3. Electric System

(3) List of CN4 terminal function (40 pins)

Pin No.	Line color	Connection	Function
CN4-82	W	Common rail pressure sensor SP terminal	It detects common rail pressure (fuel pressure). It detects fuel pressure in common rail and it converts it voltage signal and inputs it. It is used for fuel injection control. Pressure detecting voltage signal is high, when pressure is high, and it is low, when pressure is low.
CN4-83	Y/G	Fuel temperature sensor	It detects fuel temperature. Fuel temperature sensor changes resistance value according to change of internal thermistor temperature. ECM detects voltage which changes according to temperature change and it counts fuel temperature and uses it for control of supply pump. Voltage is low, when fuel temperature is high and resistance is little, and it is high, when fuel temperature is low, and resistance is large. (Resistance of thermistor is little, when temperature is high, and it is large, when temperature is low.)
CN4-84	R/B	Engine coolant temperature (ECT) sensor	It detects engine coolant temperature. It detects voltage which changes according to resistance and then it counts engine coolant temperature, used for emergency stop determination.
CN4-85	—	NIL	
CN4-86	—	NIL	
CN4-87	R	Cam angle sensor	Power supply (DC5V) for left sensors.
	R	Common rail pressure sensor VCC terminal	
	L	EGR motor position sensor power supply terminal	
CN4-88	—	NIL	
CN4-89	R/B	Suction control valve (SCV)	Grounding
CN4-90	W	Common rail pressure sensor SP terminal	It detects common rail pressure (fuel pressure). It detects fuel pressure in common rail and it converts it voltage signal and inputs it. It is used for fuel injection control. Pressure detecting voltage signal is high, when pressure is high, and it is low, when pressure is low.
CN4-91	L	Boost pressure sensor OUT terminal	It detects engine intake pressure (boost). It counts intake air pressure (boost) from detected voltage signal for fuel injection control. Voltage is high, when pressure is high, and it is low, when pressure is low.
CN4-92	G/Y	EGR motor position sensor W terminal	It detects valve lift of EGR (exhaust, gas, re-circulation) valve.
CN4-93	G/W	EGR motor position sensor V terminal	
CN4-94	G/B	EGR motor position sensor U terminal	

3. Electric System

Pin No.	Line color	Connection	Function
CN4-95	R/W	Boost pressure sensor VCC terminal	Power supply (DC5V) for boost pressure sensor.
CN4-96	—	NIL	
CN4-97	R/B	Suction control valve (SCV)	Grounding
CN4-98	W	Cam angle sensor OUT terminal	It inputs camshaft position (CMP) signal. CMP signal is caused when cam position of camshaft passes camshaft position (CMP) sensor. ECM judges cylinder according to CMP signal, and it decides crank angle and counts fuel injection control and engine speed. This control is performed based on crankshaft position (CKP) signal detected by CN4-107 terminal, but in case crankshaft position (CKP) sensor is in trouble, it is performed based on camshaft position (CMP) signal.
CN4-99	—	NIL	
CN4-100	B/W	Cam angle sensor Common rail pressure sensor shield	Noise prevention
CN4-101	L/W	Cam angle sensor	Grounding
	B	Common rail pressure sensor GND terminal	
	B	EGR motor position sensor GND terminal	
CN4-102	—	NIL	
CN4-103	W/B	EGR DC motor V terminal	It operates EGR DC motor, and it controls valve lift of EGR valve. ECM decides EGR gas volume based on engine speed and engine load ratio (fuel injection volume) and it operates EGR valve by EGR DC motor, and also it controls EGR gas volume to be mixed in engine intake air.
CN4-104	—	NIL	
CN4-105	R/W	Suction control valve (SCV)	When power stays on, fuel is sent to common rail by pressure. Fuel injection volume to common rail is controlled by control of power supply timing of suction control valve (SCV).
CN4-106	—	NIL	
CN4-107	W	Crank angle sensor OUT terminal	It inputs crankshaft position (CKP) signal. CKP signal is caused when convex portion of flywheel passes through sensor position. ECM judges cylinder according to CKP signal, and it decides crank angle and counts fuel injection control and engine speed. This control is performed based on CKP signal, but in case crankshaft position (CKP) sensor is in trouble, it is performed based on camshaft position (CMP) signal detected by CN4-98 terminal.
CN4-108	B/W	Crank angle sensor shield	Noise prevention

3. Electric System

Pin No.	Line color	Connection	Function
CN4-109	R/L	Boost pressure sensor GND terminal	Grounding
		Boost temperature sensor	
		Crank angle sensor GND terminal	
CN4-110	W/L	EGR DC motor W terminal	Same as CN4-103 terminal.
CN4-111	W/R	EGR DC motor U terminal	
CN4-112	—	NIL	
CN4-113	R/W	Suction control valve (SCV)	When power stays on, fuel is sent to common rail by pressure. Fuel injection volume to common rail is controlled by control of power supply timing of suction control valve (SCV).
CN4-114	—	NIL	
CN4-115	—	NIL	
CN4-116	R	Injector 2 & 3	Power supply for injector 2 & 3.
CN4-117	L/W	Injector 4	When power stays on, it injects fuel to injector 4.
CN4-118	L/R	Injector 2	When power stays on, it injects fuel to injector 2.
CN4-119	L	Injector 1	When power stays on, it injects fuel to injector 1.
CN4-120	L/Y	Injector 3	When power stays on, it injects fuel to injector 3.
CN4-121	W	Injector 1 & 4	Power supply for injector 1 & 4.

(4) Power supply “OFF” for ECM

Power in ECM is not yet “OFF” 10 seconds after starter switch is OFF. In case that it is necessary to switch OFF power supply by clear memory, it is necessary that you should wait longer than 10 seconds after switching OFF key switch of power supply.

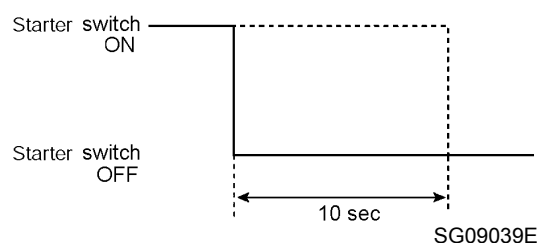

(5) Removal of ECM

1. Switch OFF starter switch.
2. Remove minus cable of battery.
3. In order to make removal job easier, remove parts such as relays around ECM.
4. Remove ECM connector from ECM. (81 pins and 40 pins connectors)
5. Loosen fixing bolts (nuts) and remove ECM.

(6) Installation of ECM

Install ECM in reverse order to disassembly.

On replacement of ECM, make sure to learn EGR valve position, taking the following procedures.

1. Switch ON starter switch “ON”.
2. Switch OFF starter switch.
3. Wait for 10 seconds in the conditions.

Without learning EGR valve position, EGR diagnostic trouble code (DTC) will be detected.

3. Electric System

3.4 Emergency Controller

Part number:46870 56600

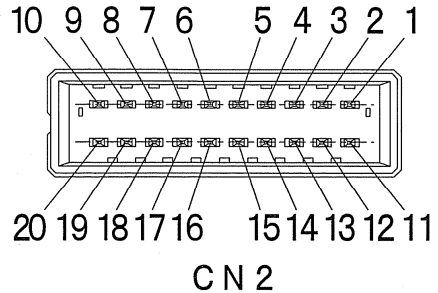
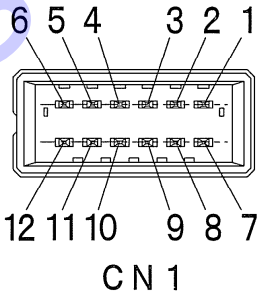
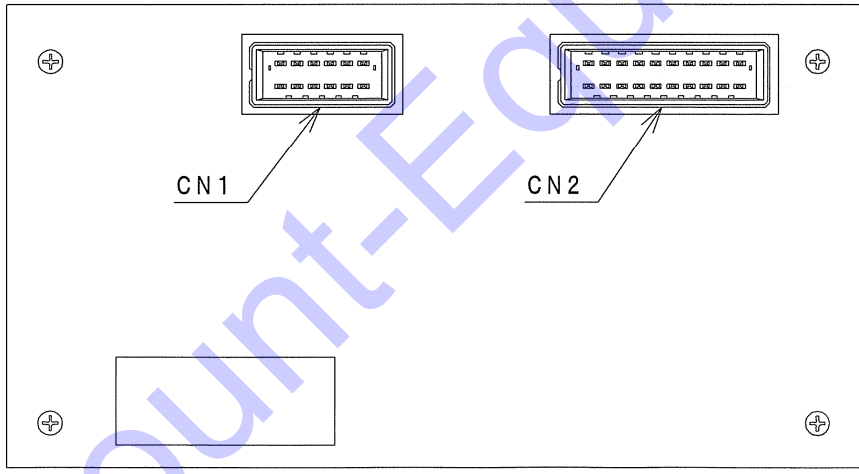
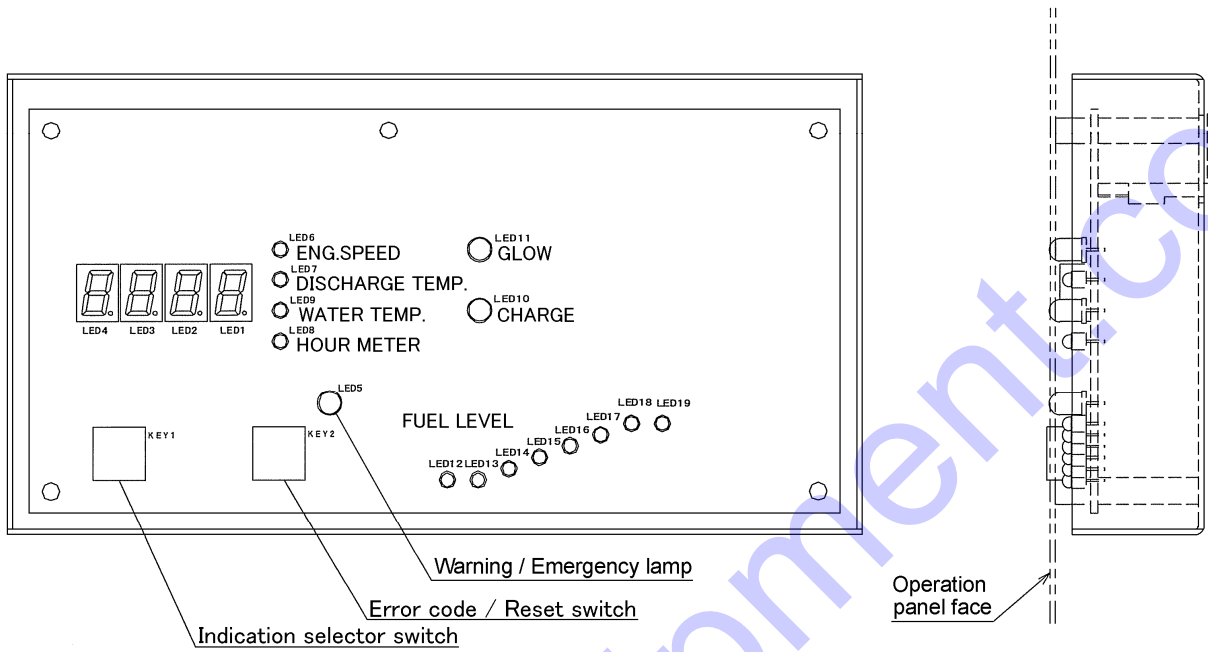

3. Electric System

1. Exterior connection drawing

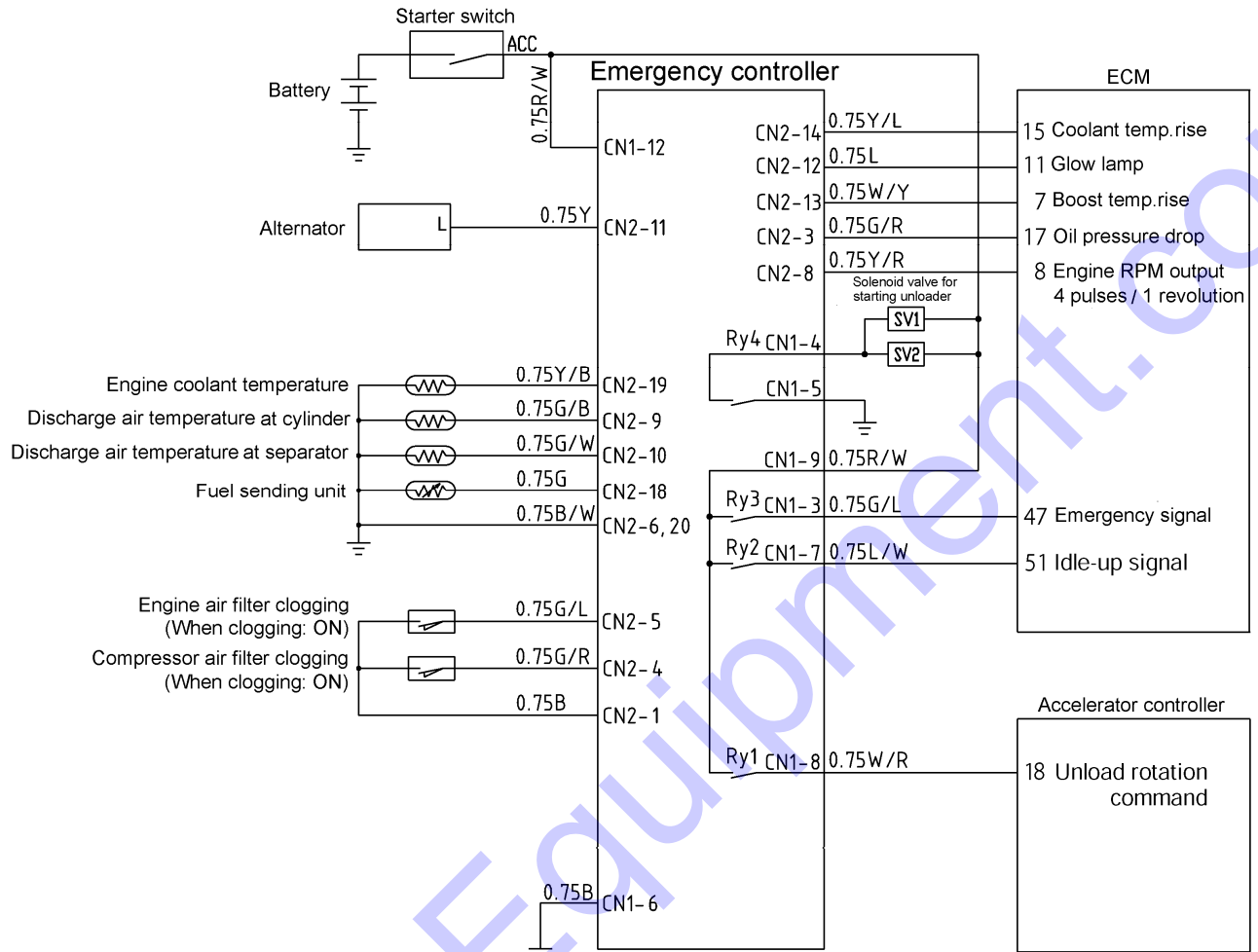

PC12069E

3. Electric System

2. Warning / emergency display and emergency stop functions

Item		Indicator	Sensor		Actuation	Detecting timing	Time lag
Warning	Discharge temp. H	A-1	Thermister	—	239°F(115°C)	Always	10.0 sec
	Water temp. H	A-2	Thermister	—	212°F(100°C)	Always	10.0 sec
	Comp. air filter	A-3	Negative pressure sw.	A contact	Differential pressure 0.9psi(6.23kPa)[0.06bar]	Always	10.0 sec
	Eng. air filter	A-4	Negative pressure sw.	A contact	Differential pressure 0.9psi(6.23kPa)[0.06bar]	Always	10.0 sec
	Charge	A-5	—	—	Charge signal disappears	After starting engine	5.0 sec
	Discharge air temp. at separator H	A-6	Thermister	—	239°F(115°C)	Always	10.0 sec
	Boost temp.	A-7	—	—	185°F(85°C)	Always	1.0 sec
	Water temp. sensor	A-8	Thermister	—	Disconnected	After warm up operation	20.0 sec
Emergency	Discharge temp. E	E-1	Thermister	—	248°F(120°C)	Always	1.0 sec
	Water temp. E	E-2	Thermister	—	221°F(105°C)	Always	1.0 sec
	Eng. oil press.	E-3	Pressure sensor	—	Oil pressure is lower than 14.6psi(0.1MPa)[1.0bar]	Controlled by the engine controller (ECM)	
	Discharge air temp. at separator E	E-4	Thermister	—	248°F(120°C)	Always	1.0 sec
	Engine speed down	E-5	—	—	Operation range of 400–1,200min ⁻¹	Always	5 seconds after start and 15 seconds cumulative
	Discharge temp. sensor	E-6	Thermister	—	Disconnected	After warm up operation	20.0 sec
	Discharge air temp. sensor at separator	E-7	Thermister	—	Disconnected	After warm up operation	20.0 sec

- Warning : Compressor continues to run.
- Emergency : Compressor stops.
- Lamp flickers / lights : The LED lamp at the upper right of the trouble code button flashes at warning conditions and it lights when it is abnormal.

3. Timing of engine start, detection of disconnection and detection of abnormal charge

● Engine start

※ Detection of engine start is done by detecting charge signal or engine speed rising signal.

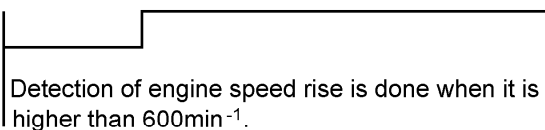

● Detection of disconnection

(Discharge/Separator air temperature, Engine coolant sensor detection of disconnection)

※ Detection starts after engine warming up operation comes to end. Time lag 20 seconds.

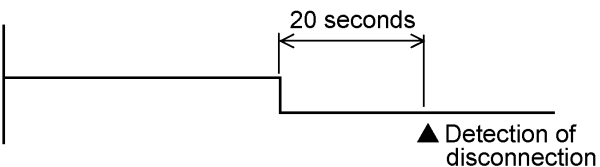

● Detection of abnormal charge

※ Detection starts after charge signal disappears after engine starts and time lag 5 seconds.

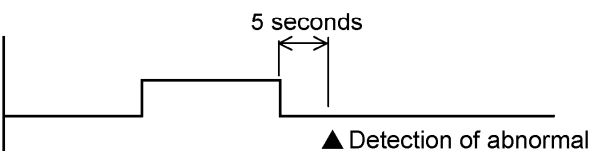

3. Electric System

4. Engine speed drop

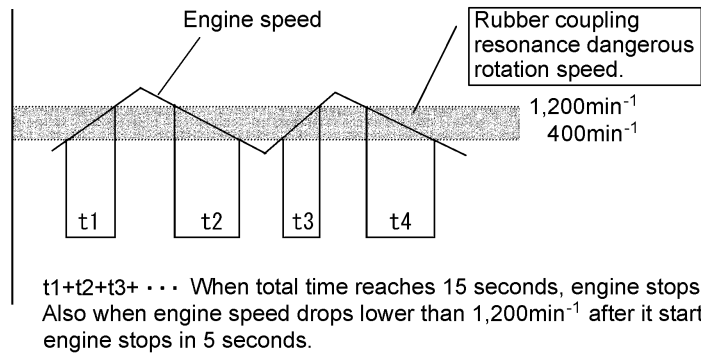

PC12019E

5. Engine speed control

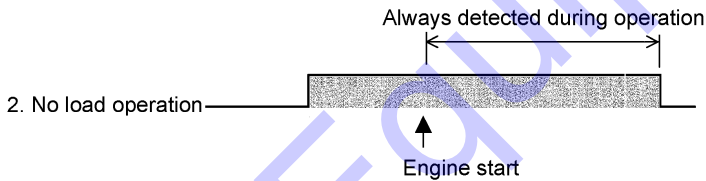
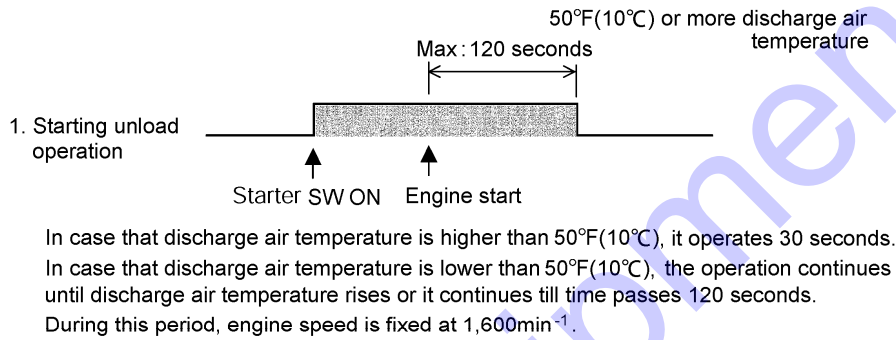

PC13069E

6. Functions of each output relay

Mark	Name	Function
RY1	Unload rotation command relay (Engine speed control)	It goes ON when starter switch is ON. Discharge air temperature: OFF in case of lower than 140°F(60°C) Discharge air temperature: ON in case of higher than 140°F(60°C)
RY2	Relay for starting unloader signal (Engine speed control)	It goes ON when starter switch is ON. Discharge air temperature: Lower than 50°F(10°C)··· When discharge air temp. is higher than 50°F(10°C), or when 120 seconds, it becomes OFF. Discharge air temperature: Higher than 50°F(10°C)··· It becomes OFF 30 seconds later.
RY3	Abnormality output relay	OFF during normal operation, ON emergency stop
RY4	Relay for starting unloader (Solenoid valve control)	It goes ON when starter switch is ON. Discharge air temperature: Lower than 50°F(10°C)··· When discharge air temp. is higher than 50°F(10°C), or when 120 seconds, it becomes OFF. Discharge air temperature: Higher than 50°F(10°C)··· It becomes OFF 30 seconds later.

3. Electric System

7. Abnormal reset

Turn "OFF" the starter switch.

8. Display function

NO.	Item	Unit
1	Eng. speed	min ⁻¹
2	Discharge temp.	°F
3	Water temp.	°F
4	Hour meter	×Hr

When power is supplied, "Eng. speed" is indicated.

Each time display selector swith is pressed, each indication will be selected. Every time the swith is pressed, the indication is changed in the order of 1→2→3→···→1···.

9. Adjustment and inspection

Perform the detection and inspection of coolant temperature, discharge air temperature, separator discharge air temperature and sending unit by controller in the following steps.

(1) Connect resistance to controller as shown right.

Or use multi-speed variable resistance
(resistance value: 1.0kΩ) for VRc1 to VRc4.

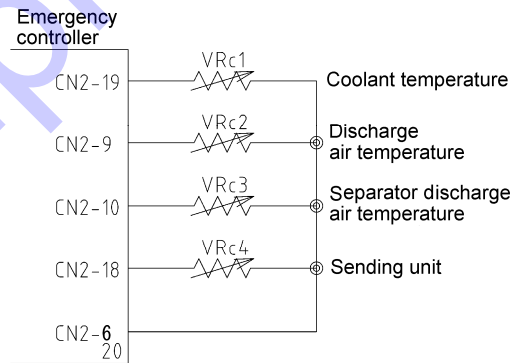

PC12021E

(2) Gradually lower resistance values of VRc1 VRc2 and VRc3 and measure them when they reach abnormal values. Then check and confirm that they are within the following ranges.

Item	Indicator	Set temperature		Resistance (Ω)
		(°F)	(°C)	
Coolant temperature	Warning	212	100	730 ± 30
	Emergency	221	105	640 ± 30
Discharge air temperature	Warning	239	115	490 ± 20
	Emergency	248	120	430 ± 20
Separator discharge air temperature	Warning	239	115	490 ± 20
	Emergency	248	120	430 ± 20

Sending unit

Float position	Resistance (Ω)
F	3 ± 2
1/2	32.5
E	110 ± 7

3. Electric System

10. List of functions

(1) Connector CN1

Pin No.	Line color	Connection	Function
CN1-1	—	NIL	
CN1-2	—	NIL	
CN1-3	G/L	Engine controller (ECM) CN3-47 terminal	No power exists during usual operation. It is connected to the emergency stop circuit of engine controller (ECM). When the interior contact (RY3) becomes “ON” due to discharge / separator discharge air temperature rise, engine coolant temperature rise, engine speed drop and engine oil pressure drop, power is sent to engine controller (ECM) CN3-47 terminal to stop engine.
CN1-4	L/W	Solenoid valve for starting unloader SV1, SV2	No power exists during usual operation. When starter switch is ON at start, and emergency controller CN1-12 terminal voltage is electrified, energizing the interior contact (RY4) is ON. Thus starting unloader solenoid valves SV1 and SV2 are activated, and lower pressure fully closes unloader valve for load reduction. Operating time of the starting unloader solenoid valve ●Discharge air temperature lower than 50°F(10°C): 120 seconds or the time till discharge air temperature rises higher than 50°F(10°C). ●Discharge air temperature higher than 50°F(10°C): For 30 seconds
CN1-5	B	Grounding	
CN1-6	B	Grounding	
CN1-7	L/W	Engine controller (ECM) CN3-51 terminal	No power exists during usual operation. When starter switch is ON at start, and emergency controller CN1-9 terminal voltage is electrified, energizing the interior contact (RY2) is ON. Thus power is sent to engine controller (ECM) CN3-51 terminal to control engine speed to 1,600min ⁻¹ . Engine speed control time of the starting unloader. ●Discharge air temperature lower than 50°F(10°C): 120 seconds or the time till discharge air temperature rises higher than 50°F(10°C). ●Discharge air temperature higher than 50°F(10°C): For 30 seconds
CN1-8	W/R	Accelerator controller CN6-18 terminal	In order to stabilize operation under unload operation, emergency controller CN1-8 interior contact (RY1) is made “OFF” and to control engine unload speed to 1,600min ⁻¹ . ●Discharge air temperature lower than 140°F(60°C): Engine speed 1,600min ⁻¹ ●Discharge air temperature higher than 140°F(60°C): Operation at a 1,300min ⁻¹ normal.
CN1-9	R/W	Starter switch [ACC] terminal (Through 10A fuse)	It is connected to emergency controller interior contacts (RY1), (RY2), (RY3). When the interior contacts are “ON”, power is sent to ECM CN3-47 and 51 terminals and accelerator controller CN6-18 terminal.
CN1-10	—	NIL	
CN1-11	—	NIL	

3. Electric System

Pin No.	Line color	Connection	Function
CN1-12	R/W	Starter switch [ACC] terminal (Through 10A fuse)	Power supply

(2) Connector CN2

Pin No.	Line color	Connection	Function
CN2-1	B	Engine air filter Compressor air filter	Grounding
CN2-2	—	NIL	
CN2-3	G/R	Engine controller (ECM) CN3-17 terminal	When engine oil pressure abnormal signal is detected emergency controller interior contact (RY3) is made "ON", power is sent to ECM CN3-7 terminal to make engine emergency stop and abnormality lamp light on. ●Emergency stop set oil pressure : Lower than 14.6psi(0.1MPa)[1.0bar]
CN2-4	G/R	Compressor air filter	It detects clogging of compressor air filter, and it enables alarm lamp to blink. ●Differential pressure for warning function : More than 0.9psi(6.23kPa)[0.06bar]
CN2-5	G/L	Engine air filter	It detects clogging of engine air filter, and it enables alarm lamp to blink. ●Differential pressure for warning function : More than 0.9psi(6.23kPa)[0.06bar]
CN2-6	B	Engine coolant temperature sensor Discharge air temperature sensor Separator discharge air temperature sensor Sending unit	Grounding
CN2-7	—	NIL	
CN2-8	Y/R	Engine controller (ECM) CN3-8 terminal	It detects (4 pulses per 1 revolution) engine speed, and displayed on the operation panel.
CN2-9	G/B	Discharge air temperature sensor	Detect the discharge air temperature. The interior contact (RY3) of emergency controller is made "ON" when the discharge air temperature becomes higher than emergency stop set temperature and power is sent to ECM CN3-1 terminal to bring engine to emergency stop, and to make the lamp flash when warning, and to make the lamp light on when engine is abnormal. ●Warning·Emergency stop set temperature Warning temperature : 239°F(115°C) Emergency stop temperature: 248°F(120°C)

3. Electric System

Pin No.	Line color	Connection	Function
CN2-10	G/W	Separator air temperature sensor	Detect the separator air temperature. The interior contact (RY3) of emergency controller is made "ON" when the discharge air temperature becomes higher than emergency stop set temperature and power is sent to ECM CN3-1 terminal to bring engine to emergency stop, and to make the lamp flash when warning, and to make the lamp light on when engine is abnormal. ●Warning·Emergency stop set temperature Warning temperature : 239°F(115°C) Emergency stop temperature: 248°F(120°C)
CN2-11	Y	Alternator L terminal	It detects deficiency of charging battery, and it enables alarm lamp to blink.
CN2-12	L	Engine controller (ECM) CN3-11 terminal	Turn on the preheat lamp.
CN2-13	W/Y	Engine controller (ECM) CN3-7 terminal	The flickering the alarm lamp by detecting the abnormal boost temperature. ●Warning set temperature: 185°F(85°C)
CN2-14	Y/L	Engine controller (ECM) CN3-15 terminal	When engine cooling water temperature abnormal signal is detected from ECM CN3-15 terminal, the emergency controller interior contact (RY3) is made "ON" to bring engine to emergency stop. ●Emergency stop set temperature: 221°F(105°C)
CN2-15	—	NIL	
CN2-16	—	NIL	
CN2-17	—	NIL	
CN2-18	G	Sending unit	Fuel gauge operates to detect the fuel level.
CN2-19	Y/B	Engine coolant temperature sensor	Used for lighting of the warning or abnormal lamp and engine coolant temperature display.
CN2-20	B/W	Engine coolant temperature sensor Discharge air temperature sensor Separator discharge air temperature sensor Sending unit	Grounding

3. Electric System

3.5 Alternator

ISUZU part number:898092-1122

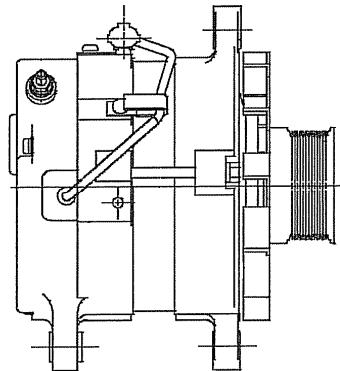
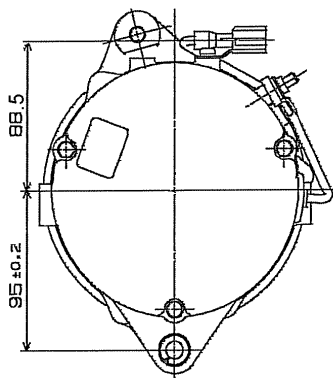

Nominal capacity	DC24V-50A
------------------	-----------

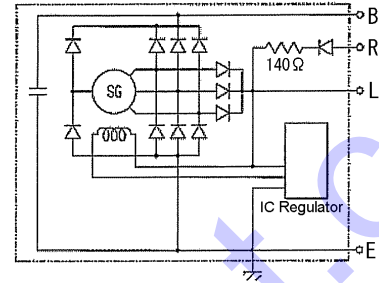

PC12038E

(1) List of functions

Pin No. (Terminal No.)	Line color	Connection	Function
(B)	Y	Starter motor B terminal (Through 60A fuse)	Power for charging voltage.
CN14-1(R)	R/Y	Starter switch ACC terminal	Detect voltage of ACC terminal and adjust the current flowing to rotor coil
CN14-2(L)	Y	Emergency controller CN2-11 terminal	Generation signal is outputted to emergency controller. After engine starts, and if generation signal will not occur, charging malfunction warning lamp is made to light on. Time lag : 5 seconds
			Output of hour-meter function signal
E	B	Grounding	—

(2) How to check

Checking method by voltage measurement	Normal value
Measure the battery terminal voltage at full load operation.	DC28.5±0.5V

(3) Check and confirm the following when faulty charging warning lamp lights on

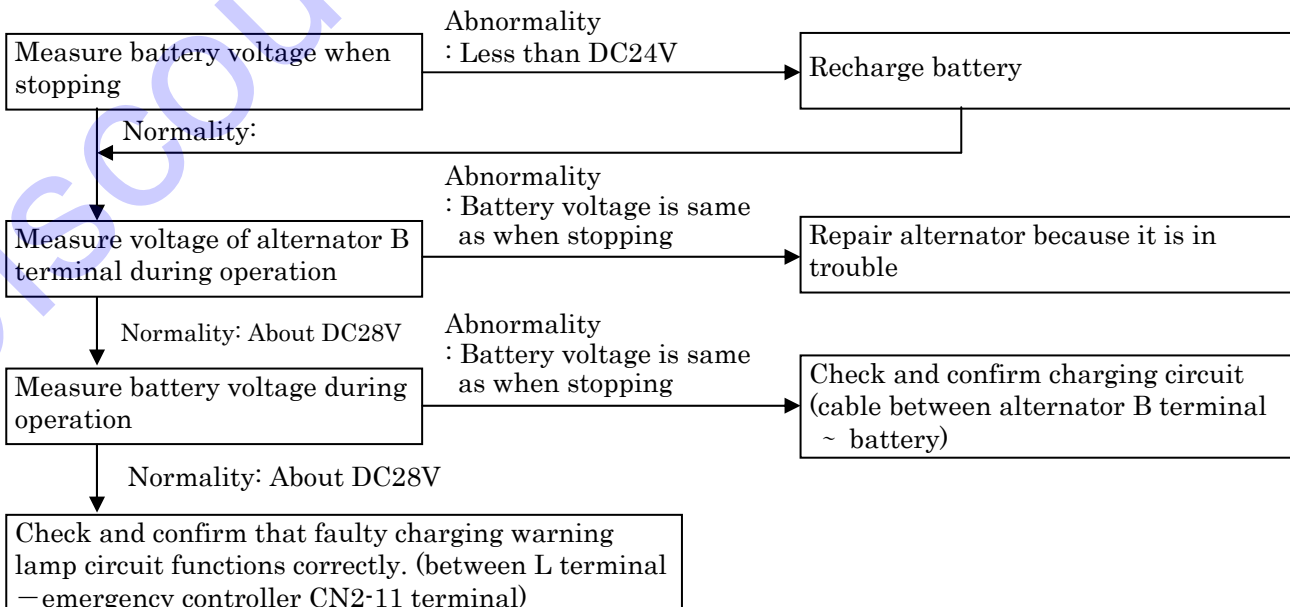

3. Electric System

3.6 Starter

ISUZU part number:898045-0272

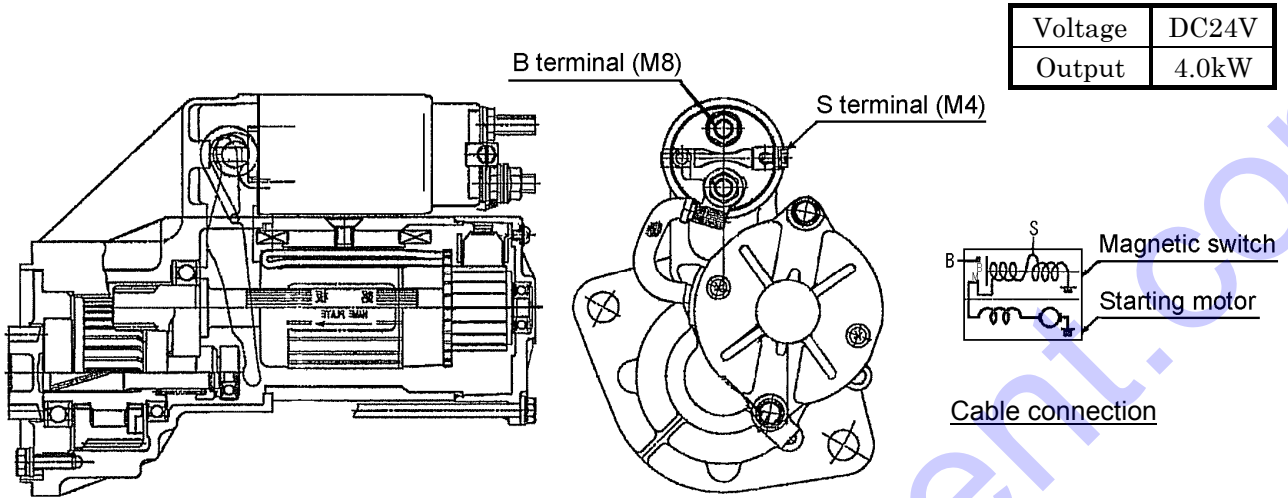

Voltage	DC24V
Output	4.0kW

PC12039E

(1) List of functions

Terminal No.	Line color	Connection	Function
B	R	Starter switch B terminal Battery + terminal	For supplying power to starter which enables starter pinion to turn.
S	W	Starter relay C terminal	For supplying power to make starter pinion to spring out and also a little power to make pinion turn for smooth engagement between pinion gear and ring gear when they are in contact.

3. Electric System

3.7 Solenoid Valve for Starting Unloader

3.7.1 Unloader piston actuation:SV1

Part number:46811 27100

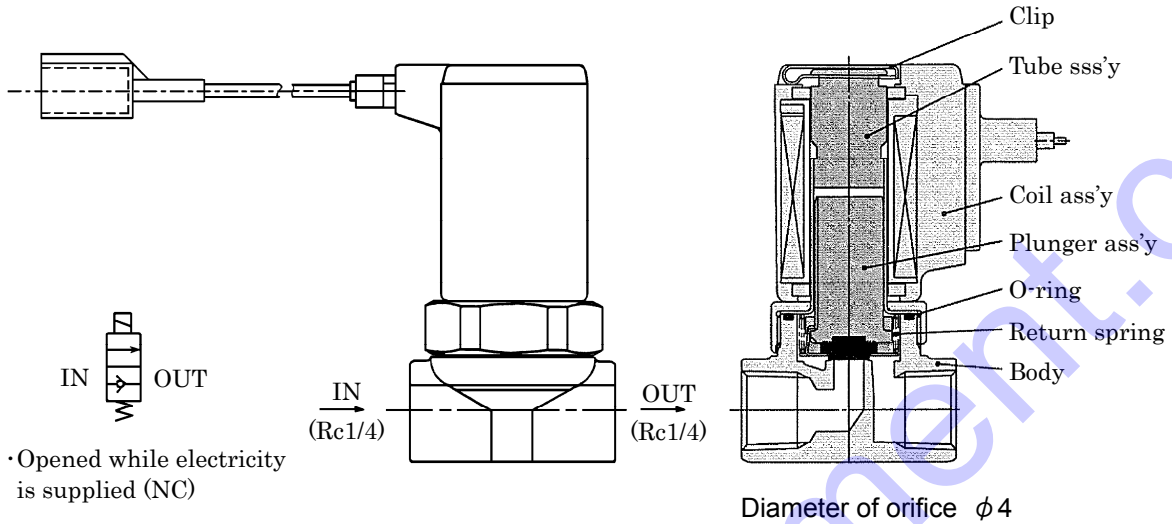

PC10037

Rated voltage	DC24V
Function	Power is supplied. It is ON (NC)

3.7.2 Unloader spring chamber negative pressure:SV2

Part number:46811 28700

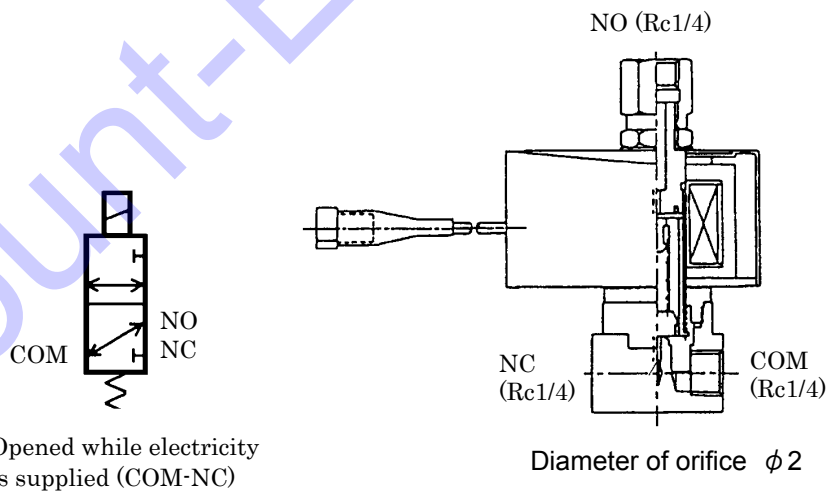

PC12065

Rated voltage	DC24V
Function	Power is supplied. It is ON (COM-NC)

3. Electric System

3.8 Air Filter Indicator (Engine / Air-end common)

Part number:32148 03000

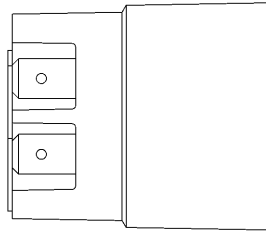
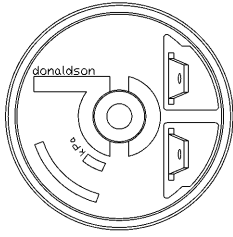

Operating resistance	6.2kPa
Contact type	A contact

SC10016

3.9 Pressure Sensor (Secondary pressure of regulator detect)

Part number:44328 20600

Trouble diagnosis of pressure sensor itself

Check and confirm that output voltage between ②-③ is 0.5 ±0.1V when DC5V is applied between ①-③ terminals at an atmospheric pressure.

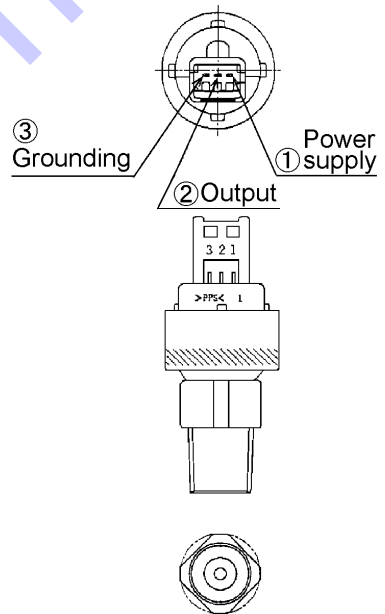

Pressure and output voltage(for reference only)

Electric wire	Signal
①VCC	Power supply (DC5V)
②VOUT	Output
	Pressure 0psi (0MPa) [0bar] DC0.5V
	Pressure 14psi (0.1MPa) [1bar] DC0.9V
	Pressure 85psi (0.6MPa) [6bar] DC2.9V
	Pressure 100psi (0.69MPa) [6.9bar] DC3.3V
Pressure 142psi (0.98MPa) [9.8bar] DC4.5V	
③GND	Grounding

PC08035E

3. Electric System

3.10 Discharge Air Temperature·Separator Air Temperature· Engine Coolant Temperature Sensor (Thermister)

※Engine coolant temperature sensor, used in abnormal or alarm lamp and temperature display.

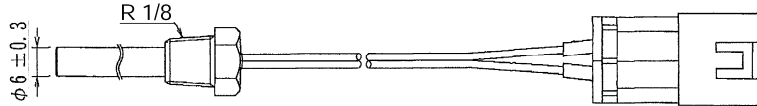

SC14066

44364 08200 Sensor

(~0154) Part number:44364 06500

Characteristic of temperature·resistance

Temperature °F(°C)	Resistance value (Ω)	Permissible value (%)	Temperature °F(°C)	Resistance value (Ω)	Permissible value (%)
68(20)	11,600	±9	176 (80)	1,300	±7
95(35)	6,280	±8	203 (95)	840	±6
122(50)	3,580	±7	230(110)	560	±5
149(65)	2,120	±7	239(115)	490	±6

(0155~) Part number:44364 08200

Characteristic of temperature·resistance

Temperature °F(°C)	Resistance value (Ω)	Permissible value (%)	Temperature °F(°C)	Resistance value (Ω)	Permissible value (%)
68(20)	11,620	±10	176 (80)	1,310	±6
95(35)	6,270	±9	203 (95)	840	±5
122(50)	3,560	±8	230(110)	560	±4
149(65)	2,120	±7	239(115)	490	±4

《Note》 Take care not to tighten excessively. Less than 17.7lbf·in.(2N·m)[20kgf·cm]

3.11 Fuel Meter (Display)

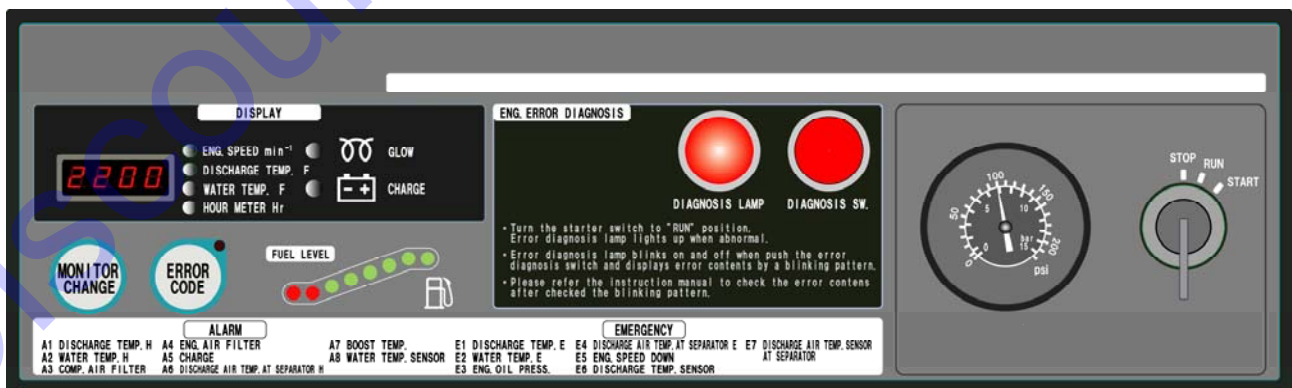

A120171

3. Electric System

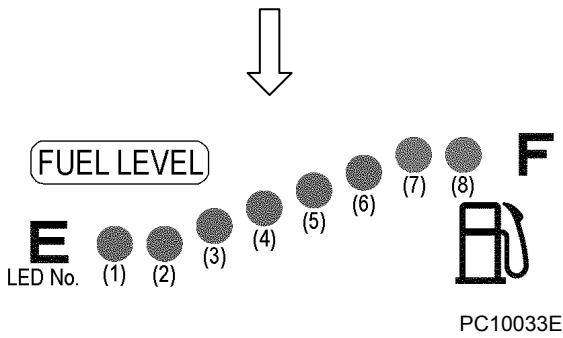

Relation between indicator lamp (LED) and residual fuel level

Indicator lamp		Remaining fuel gal.(L)	Remark
Full tank		46(175)	F
LED No.8	OFF (Green)	44(167)	
LED No.7	OFF (Green)	40(150)	
LED No.6	OFF (Green)	34(127)	
LED No.5	OFF (Green)	28(107)	1/2
LED No.4	OFF (Green)	24 (89)	
LED No.3	OFF (Green)	18 (69)	
LED No.2	OFF (Red)	14 (53)	
LED No.1	Blinking (Red)	10 (37)	E

※Value when began to consume the fuel (F→E).

3.12 Sending Unit

Part number:36159 02202

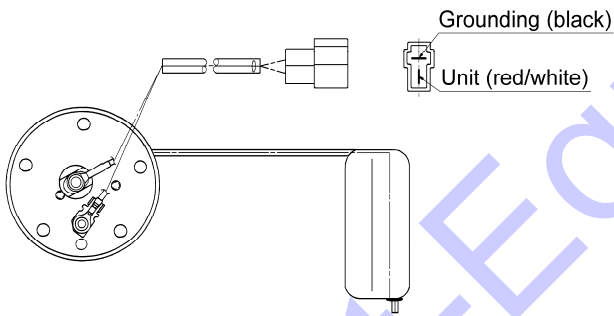

Float position	Resistance value (Ω)
F	3.0 ± 2.0
1/2	32.5
E	110.0 ± 7.0

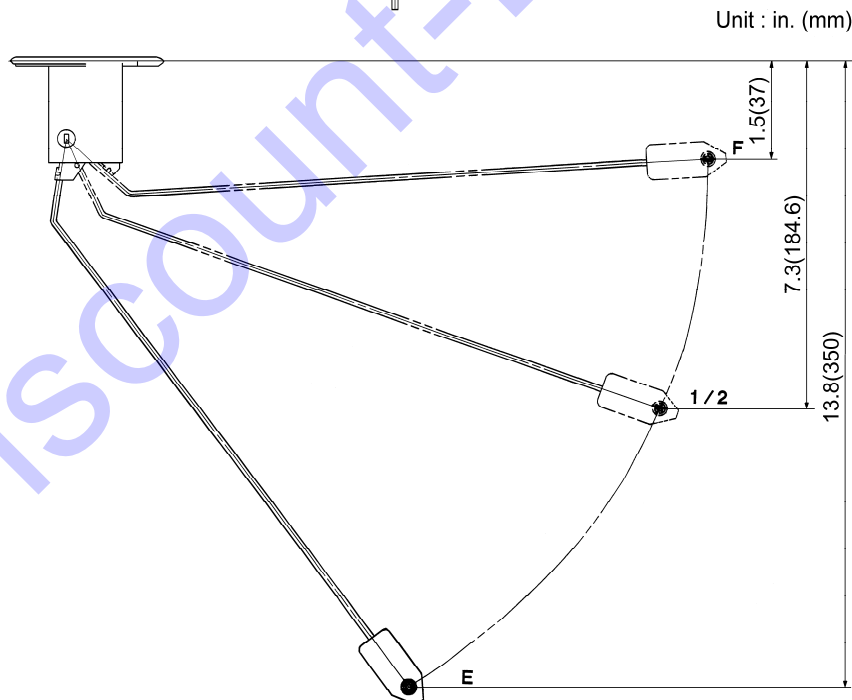

PC13070E

3. Electric System

3.13 Fuel Air-bleeding Electromagnetic Pump (Type with built-in filter)

Part number :43650 02500

ISUZU part number:898009-3971

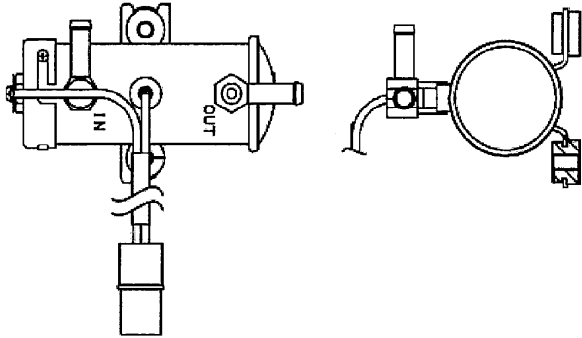

Part number of filter
ISUZU part number:898071-4010

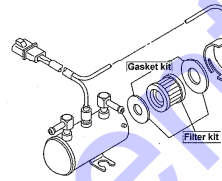

PC12098

3.14 Main Safety Relay, MR·SR

Part number :44324 05800

ISUZU part number:898013-7900

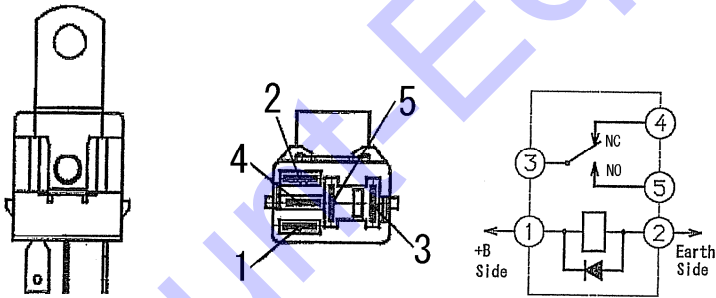

Rated voltage	DC24V
Capacity of contact point	NO circuit 10A
	NC circuit 5A

※Main relay using the NO circuit.

Safety relay using the NC circuit.

PC12042

3. Electric System

3.15 Electromagnetic Pump Relay, FR

Part number :44346 07500
ISUZU part number:582550-0300

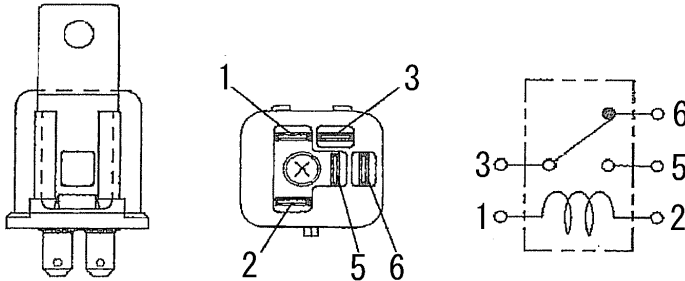

Rated voltage	DC24V
Capacity of contact point	Lamp load 150W
	Others 12.5A

PC12043

3.16 Glow Relay, GR

Part number :44346 15500
ISUZU part number:894460-7061

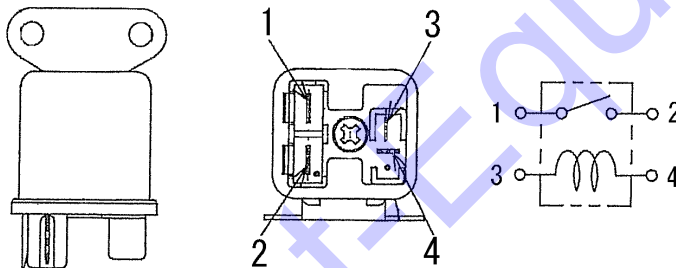

Rated voltage	DC24V
Rated load	Rush current 50A
	Braking current 30A
Coil resistance	100Ω

PC12044

3.17 Starter Relay, SY

Part number :44346 15600
ISUZU part number:898005-6310

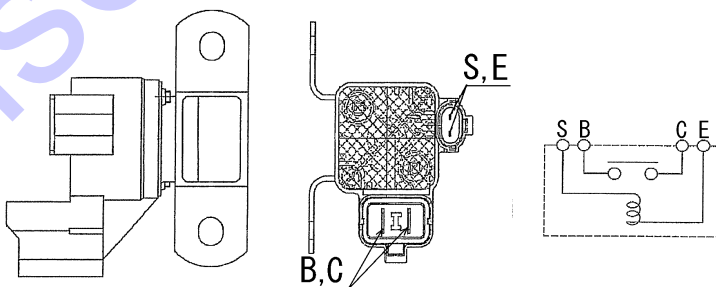

Rated voltage	DC24V
Rated	30 sec
Contact allowable current	Instantaneous 200A
	30 sec 35A

PC12045,46

3. Electric System

3.18 Electronic Control Engine Component Engine component location diagram

[Excerpt ISUZU troubleshooting manual]

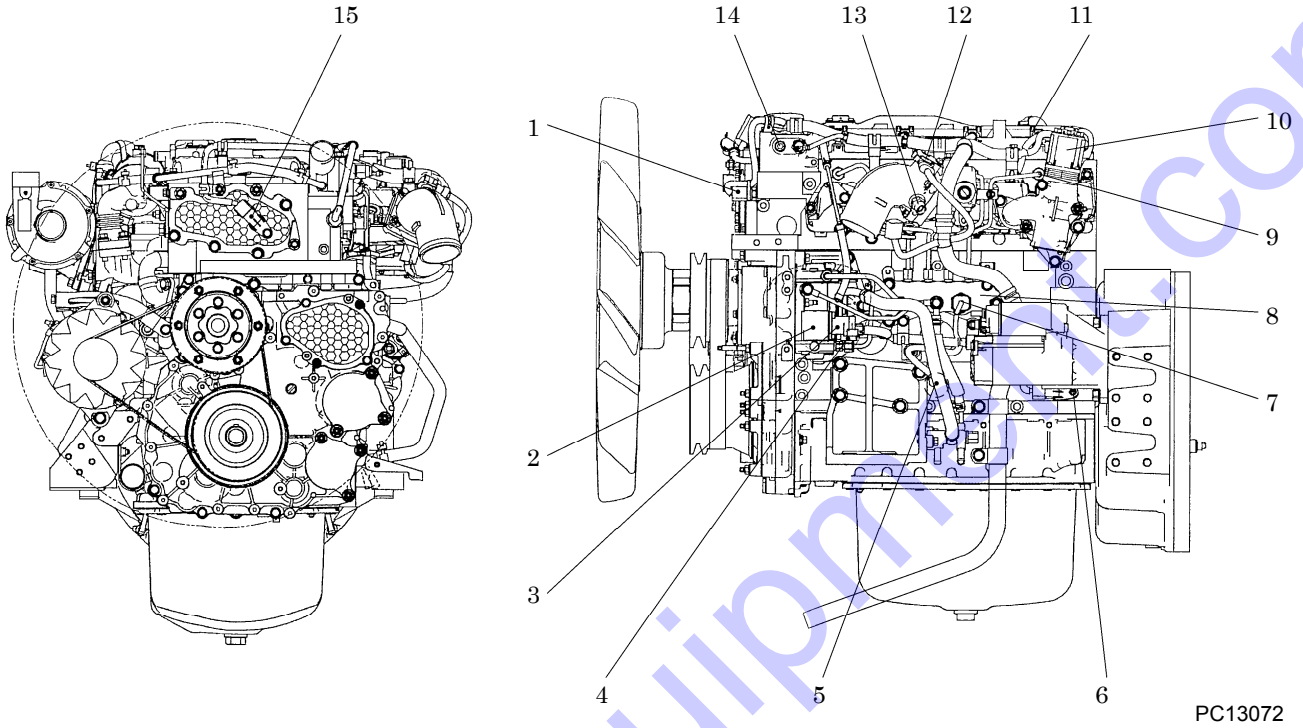

Operation panel

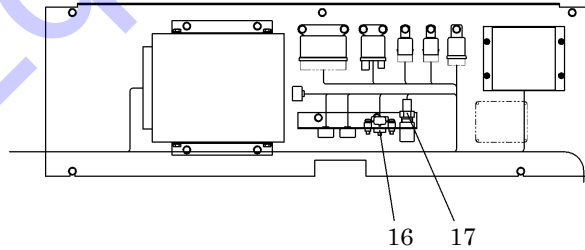

- | | |
|--|---|
| 1. Engine coolant temperature (ECT) sensor | 10. EGR valve |
| 2. Supply pump | 11. Glow plug |
| 3. Suction control valve (SCV) | 12. Boost pressure sensor |
| 4. Fuel temperature (FT) sensor | 13. Boost temperature sensor |
| 5. Engine oil pressure sensor | 14. Coolant temperature sensor |
| 6. Crankshaft position (CKP) sensor | 15. Camshaft position (CMP) sensor |
| 7. Common rail pressure sensor | 16. Barometric pressure sensor (Mounting on the operation panel) |
| 8. Common rail | 17. Intake air temperature sensor (Mounting on the operation panel) |
| 9. Injector | |

3. Electric System

3.18.1 Supply pump

The supply pump pressurizes fuel using engine output, and pressure-feeds fuel to common rail. The supply pump has suction control valve (SCV), fuel temperature (FT) sensor and feed pump.

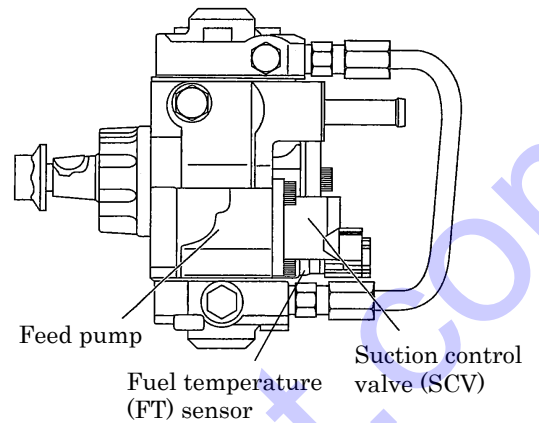

PC13091

3.18.2 Suction control valve (SCV)

The suction control valve (SCV) is installed onto supply pump section and controls pressure feed of fuel (discharge amount) to common rail. The engine control module (ECM) regulates period of electric conduction of suction control valve (SCV) to regulate the fuel discharge amount.

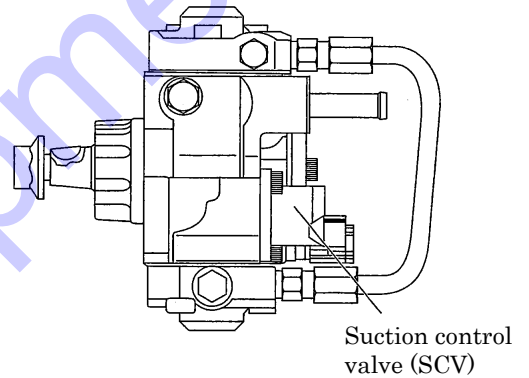

PC13092

Note:

The connector parts of suction control valve (SCV) are different in color between 12V and 24V.

12V : Light gray

24V : Light brown

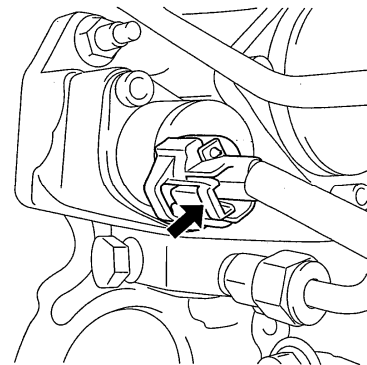

PC13093

3. Electric System

3.18.3 Fuel temperature (FT) sensor

The fuel temperature (FT) sensor is installed onto the supply pump, and the thermistor changes the resistance according to the temperature. The resistance is low when the fuel temperature is high, and is high when the temperature is low. The ECM energizes the voltage 5V to the fuel temperature (FT) sensor through pull up resistance, and calculates fuel temperature based on change of voltage to use for various controls such as supply pump control etc. If the resistance is low (temperature is high), the voltage becomes low; if the resistance is high (temperature is low), the voltage becomes high.

Removal

Do not replace the fuel temperature (FT) sensor.
If it is faulty, replace it as supply pump assembly.

ISUZU part number:898023-5810

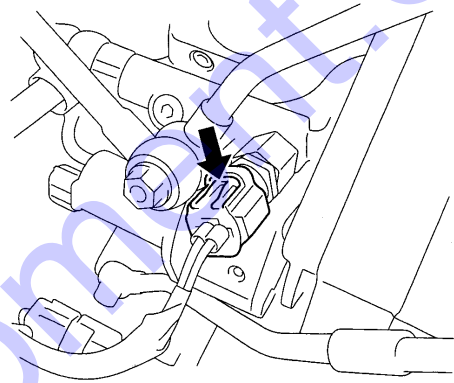
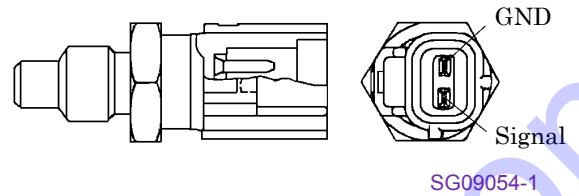

3.18.4 Common rail

The common rail receives fuel from supply pump, holds the common rail (fuel) pressure and distributes fuel to each cylinder. The common rail has common rail pressure sensor, flow damper and pressure limiter.

Note:

For work procedure, refer to engine manufacturer's "Workshop manual".

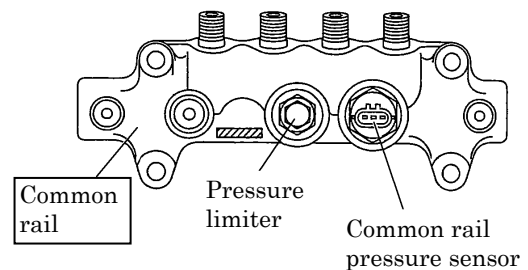

3. Electric System

3.18.5 Pressure limiter

The pressure limiter operates to release the pressure in common rail when the pressure becomes extremely high.

Removal

Do not replace the pressure limiter.

If it is damaged, replace it as common rail assembly.

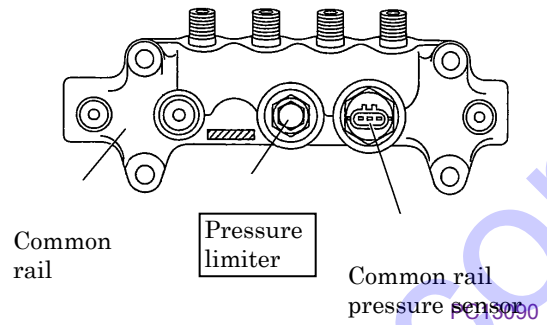

3.18.6 Common rail pressure sensor

The common rail pressure sensor is installed onto common rail, detects fuel pressure in common rail, converts the pressure into the voltage signal and sends it to ECM. Voltage becomes higher as pressure becomes higher, and lower as one dose lower. ECM calculates the actual common rail pressure (fuel pressure) based on the voltage signal sent from sensors and uses it for fuel injection control etc.

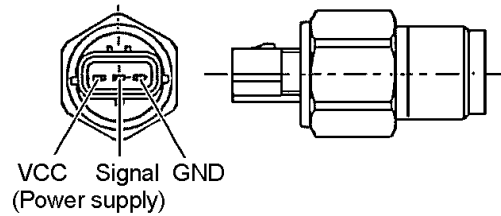
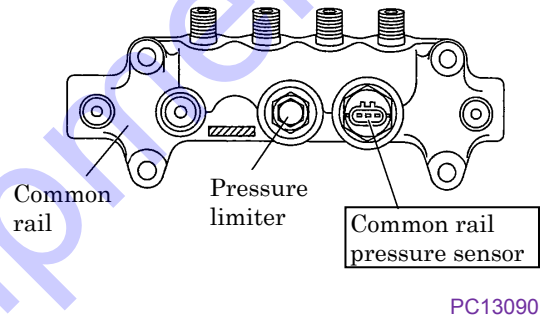

Removal

Do not replace the common rail pressure sensor.

If it is damaged, replace it as common rail assembly.

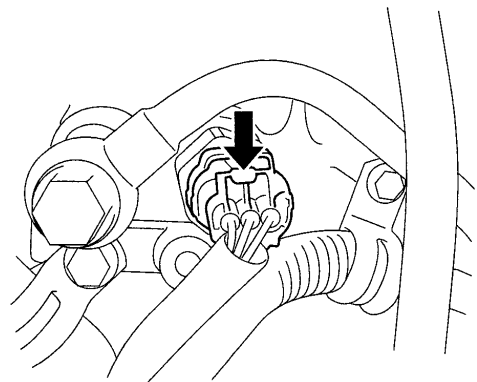

3. Electric System

3.18.7 Injector

The injector is installed onto cylinder head section and is controlled by ECM to inject fuel. The ECM raises the voltage for operating injectors internally, energizes to injector, and regulates period of electric conduction of injector to control fuel injection amount and injection timing.

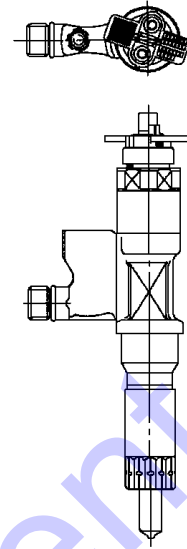

SG09058

3.18.8 Engine coolant temperature (ECT) sensor

The engine coolant temperature (ECT) sensor is installed onto cylinder head, and the thermistor changes the resistance according to the temperature. Resistance is low at high engine coolant temperature and high at low engine coolant temperature. The ECM energizes the voltage 5V to the ECT sensor through pull up resistance, and calculates engine coolant temperature based on change of voltage to use for various controls such as fuel injection and emergency stop decision etc. If the resistance is low (temperature is high), the voltage becomes low; if the resistance is high (temperature is low), the voltage becomes high.

When coolant temperature rises higher than 221°F (105°C), warning lamp is made to light on to bring engine to emergency stop.

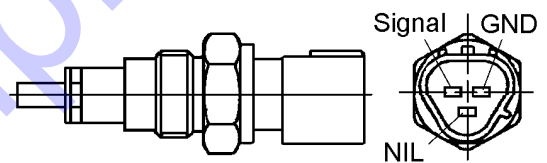

SG09059-1E

Removal

Disconnect the connector and remove it with 0.75in. (19mm) wrench.

Installation

Apply Loctite 572 before installing it.

 : 173–260lbf·in (19.6–29.4N·m)
[200–300kgf·cm]

ISUZU part number:898156-6480

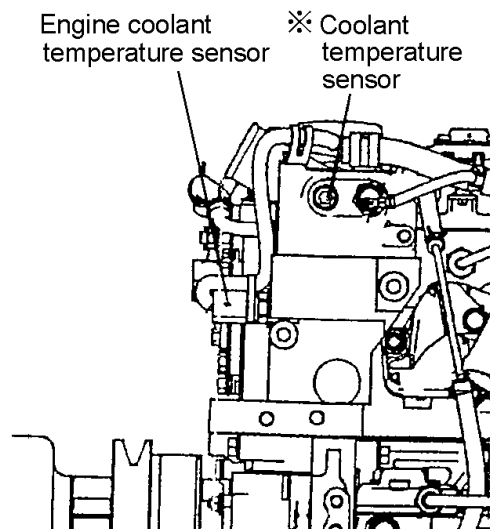

PC13071E

※Engine coolant temperature sensor Hokuetsu

Industries be ordered. Used in abnormal / alarm lamp and temperature display. Refer to 3.10 Discharge Air Temperature·Separator Air Temperature·Engine Coolant Temperature Sensor.

3. Electric System

3.18.9 Crankshaft position (CKP) sensor

The crankshaft position (CKP) sensor is installed onto **engine block** and produces the CKP signal when the convex portion of flywheel passes the sensor. The ECM distinguishes the cylinders by the CMP signal input from camshaft position (CMP) sensor, determines the crank angle and uses it to control fuel injection and calculate the engine speed. These controls are performed, usually based on CKP signal. However it is done, based on CMP signal if the crankshaft position (CKP) sensor is faulty.

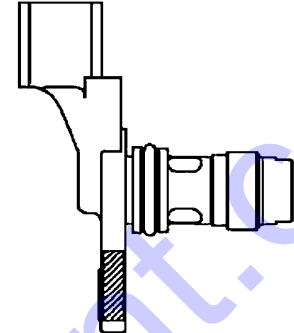
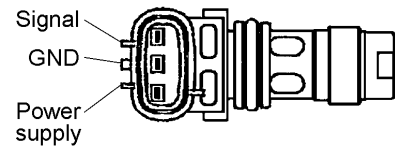

PC13075E

Removal

Disconnect the connector, and remove the **0.4in. (10mm)** mounting bolt and sensor.

Installation

 : 130–217lbf·in (14.7–24.5N·m)
[150–250kgf·cm]

ISUZU part number: 897312-1081

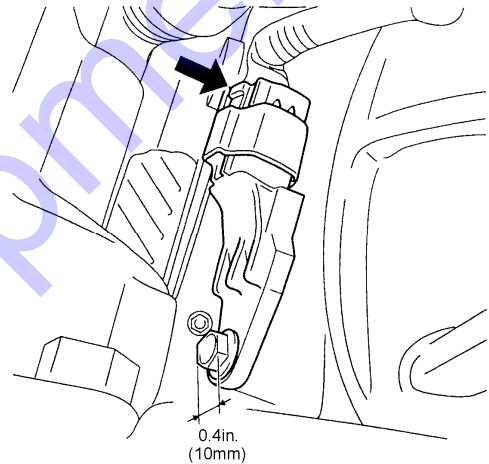

PC13076

3. Electric System

3.18.10 Camshaft position (CMP) sensor

The camshaft position (CMP) sensor is installed onto the **front** of cylinder head and produces the CMP signal when the cam portion of camshaft passes the sensor. The ECM distinguishes the cylinders by the CMP signal input from camshaft position (CMP) sensor, determines the crank angle and uses it to control fuel injection and calculate the engine speed. These controls are performed, usually based on CKP signal. However it is done, based on CMP signal if the crankshaft position (CKP) sensor is faulty.

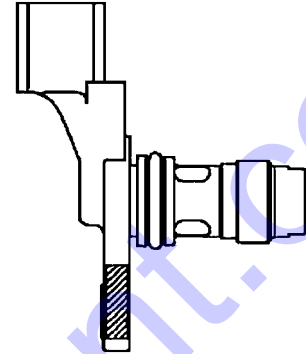
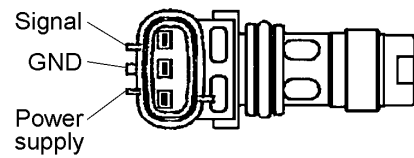

PC13075E

Removal

Disconnect the connector, and remove the **0.4in. (10mm)** mounting bolt and sensor.

Installation

Apply a coat of engine oil to the O-ring.

 : $69 \pm 18 \text{ lbf} \cdot \text{in}$ ($7.8 \pm 2 \text{ N} \cdot \text{m}$) [$80 \pm 20 \text{ kgf} \cdot \text{cm}$]

ISUZU part number: 897312-1081

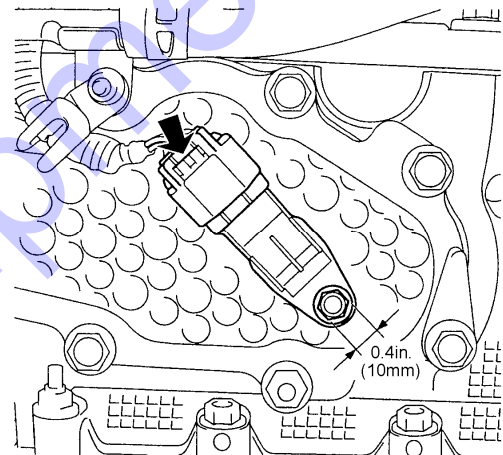

PC13077

3.18.11 Engine oil pressure sensor

The engine oil pressure sensor is installed near the starter motor of the cylinder block; it detects engine oil pressure, converts the pressure into the voltage signal and sends it to ECM. Voltage becomes higher as pressure becomes higher, and lower as one does lower.

When oil pressure drops lower than 7.3psi (0.05MPa) [0.5bar], warning lamp is made to light on to bring engine to emergency stop.

Removal

Disconnect the connector and remove it with **1.1in. (27mm)** wrench.

Installation

 : $354 \text{ bf} \cdot \text{in}$ ($40 \text{ N} \cdot \text{m}$) [$410 \text{ kgf} \cdot \text{cm}$]

ISUZU part number: 898027-4560

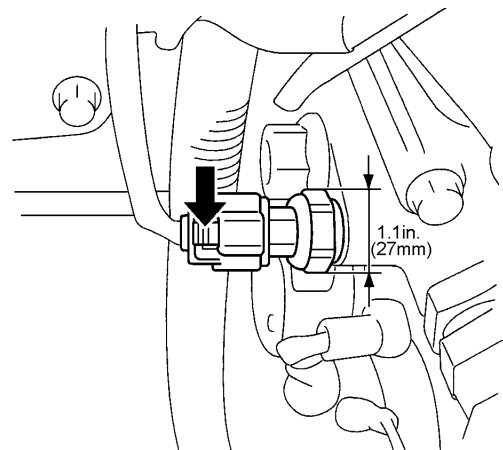
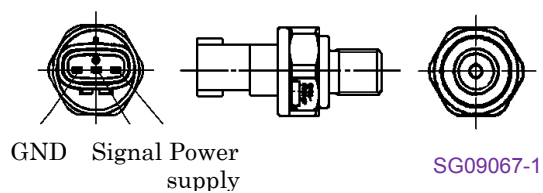

SG09068-1

3. Electric System

3.18.12 Barometric pressure sensor

The barometric pressure sensor is installed into the operation panel and converts the barometric pressure into voltage signal. The ECM calculates barometric pressure by voltage signal and performs fuel injection amount correction (high-altitude correction) etc. by barometric pressure.

Part number :44328 21500
ISUZU part number:897217-7780

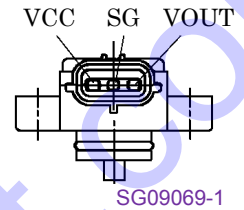
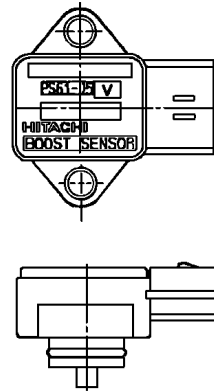

SG09069-1

Atmospheric pressure and output voltage (Reference value)

Cable	Signal
①VCC	Power supply (DC5.12±0.5V)
②VOUT	Output
	Atmospheric pressure 5.8psi (40kPa) [0.4bar] DC1.00V
	17.5psi (120kPa) [1.2bar] DC2.28V
③SG	Grounding

Standard atmospheric pressure
1atm:14.7psi(101.3kPa)[1.013bar]

3.18.13 Intake air temperature (IAT) sensor

The intake air temperature (IAT) sensor is installed into the operation panel and detects the temperature of intake air for optimum fuel injection control.

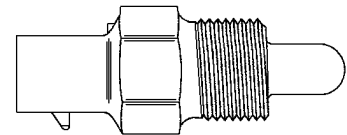
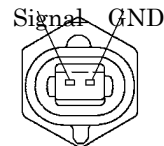

SG09070-1

⚙️: 96–144lb·in(10.8–16.3N·m) [110–166kgf·cm]

Part number :44364 06600
ISUZU part number:812146-8300

Characteristic of temperature and resistance
(Reference value)

Temperature °F (°C)	Resistance value (Ω)	Permissible value (%)
-4 (-20)	28,583	± 4.0
14 (-10)	16,120	± 3.6
40 (5)	7,263	± 3.0
68 (20)	3,511	± 2.6
95 (35)	1,806	± 2.4
104 (40)	1,465	± 2.3

3. Electric System

3.18.14 EGR position sensor

It is installed in EGR valve and detects the valve lift amount of EGR.

Exhaust gas emitted from engine is mixed again with intake air and combustion temperature is lowered to reduce Nox and it is used as, EGR system sensor.

Conector terminal number, function (Reference value)

Terminal No.	Function
1	Position sensor power supply (+5V)
2	Position sensor W terminal
3	Position sensor V terminal
4	Position sensor U terminal
5	Position sensor GND
6	DC motor W terminal
7	DC motor V terminal
8	DC motor U terminal

Note:

Do not disassemble the EGR position sensor. If it is faulty, replace it as EGR valve assembly.

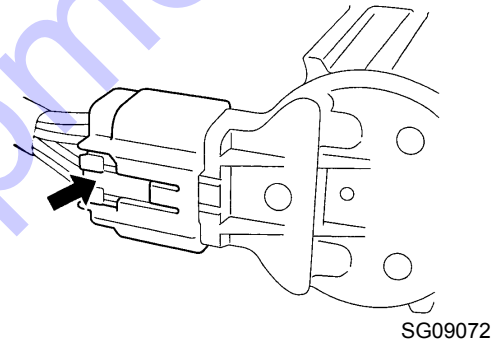
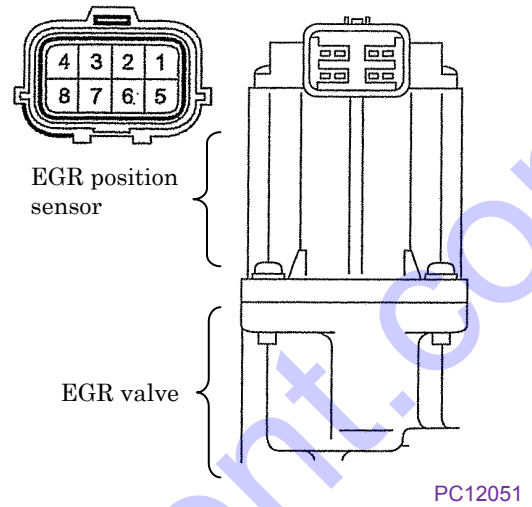

3. Electric System

3.18.15 Boost pressure sensor

The boost pressure sensor detects boost pressure (intake air pressure) in intake manifold, converts the pressure into the voltage signal and sends it to ECM. Voltage becomes higher as pressure becomes higher, and lower as one dose lower. ECM calculates the boost (intake air pressure) based on the voltage signal sent from sensors and uses it for fuel injection control etc.

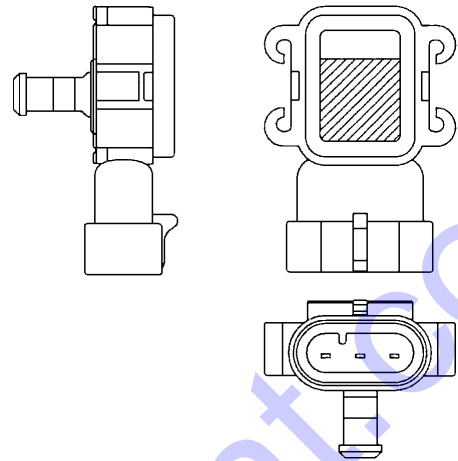

PC13073

Removal

Disconnect the connector, and remove the two 0.4in. (10mm) mounting bolts, hoses and sensor.

Installation

 : 35–53lbf·in (4–6N·m) [40.8–61.2kgf·cm]

ISUZU part number:828139-7750

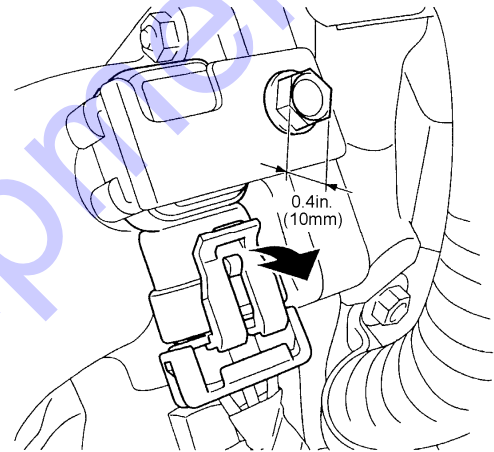

PC13078

3.18.16 Boost temperature sensor

The boost temperature sensor is installed onto the EGR valve upstream side of intake manifold. The sensor is thermistor type. The resistance in the sensor changes as the temperature changes.

Signal GND

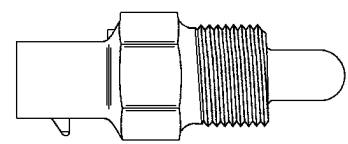
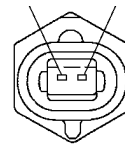

SG09070-1

Removal

Disconnect the connector and remove it with 0.75in. (19mm) wrench.

Installation

 : 96–144lbf·in (10.8–16.3N·m) [110–166kgf·cm]

ISUZU part number:812146-8300

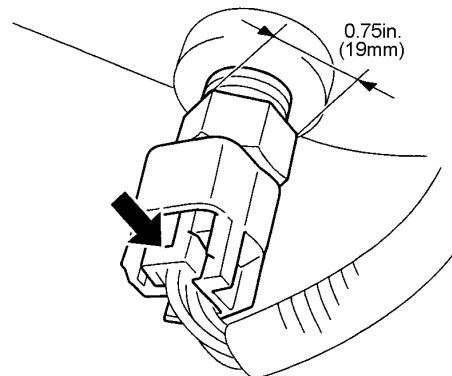

SG09075

4. Troubleshooting

4.1 Repairing Procedures

When performing failure diagnosis, pay special attention to the followings, observing general cautions.

4.1.1 Safety caution

- (1) Removing such cap and/or plug for receiver tank, fuel tanks and pipes where pressure is loaded, stop the machine and relieve all the interior pressure. Install measuring instruments connected firmly.
- (2) When doing the job with co-worker(s) together, make sure to give signal to the other person(s) and do not allow other persons to come near to the job site.
- (3) Take care not to touch hot portions and not to be involved in turning portions.

4.1.2 Caution during failure diagnosis

- (1) Do not make haste to disassemble the unit

If the unit is disassembled urgently.

- ① You may disassemble the other portions which are not related with the trouble.
- ② The cause of trouble may be missing.

The unnecessary reparations require more spare parts and man-hours, and reparation costs will increase more. What is worse, you will lose reliance or trust from clients, operators and users.

Therefore, it is absolutely necessary to investigate the trouble more carefully in advance and to follow the required procedures for failure diagnosis.

- (2) Ask the clients about the trouble in details

In order to prevent misunderstanding and incorrect judgment about the trouble, it is necessary to ask users or operators about the following questions.

- ① Is there any other disorder than the trouble he has informed?
- ② Anything abnormal occurred before this trouble?
- ③ Did this trouble happen unexpectedly? Or the unit had been operated in bad conditions before?
- ④ When and how did this trouble occur?
- ⑤ Had he repaired the unit before this trouble occurred?
- ⑥ Did he not experience similar trouble before?

- (3) Inspection items before starting diagnosis

Sometimes such trouble may be caused owing to routine mishandling of the unit. Before starting failure diagnosis, check the following items.

- ① The engine runs short of engine oil or its oil is not dirty?
- ② Check each wire connection for any disconnection.
- ③ Check the other portions for any damage.

- (4) Confirmation of trouble

Discuss with user(s) and/or operator(s) sufficiently about the trouble. As a result, judge whether their judgment is based on the numerical comparison or sentimental basis. Make him (them) understand well the reparation or correction you have finished.

Then check and confirm by yourself the cause of the trouble.

Note) Never proceed any investigation or measurement which may cause further greater damage.

4. Troubleshooting

(5) Procedures of diagnosis

When you become well experienced, you can find out the cause easily during the process of confirmation (4). But easy understanding could cause unexpected failure. So check and judge it according to the following procedures.

- ① Check the easiest thing or portion first.
- ② Investigate the most possible cause.
- ③ Check the other things connected to the trouble.
- ④ Check for the possibility of any other troubles.
- ⑤ Start proper and careful investigation on this trouble.

(6) Prevention of repeated occurrence of similar trouble

Even if you have repaired the trouble, unless you get rid of the fundamental cause of the trouble, it will repeatedly occur. Therefore, perform full investigation of the trouble, and it is absolutely necessary to remove the basis of the trouble.

4.1.3 How to use the failure diagnosis

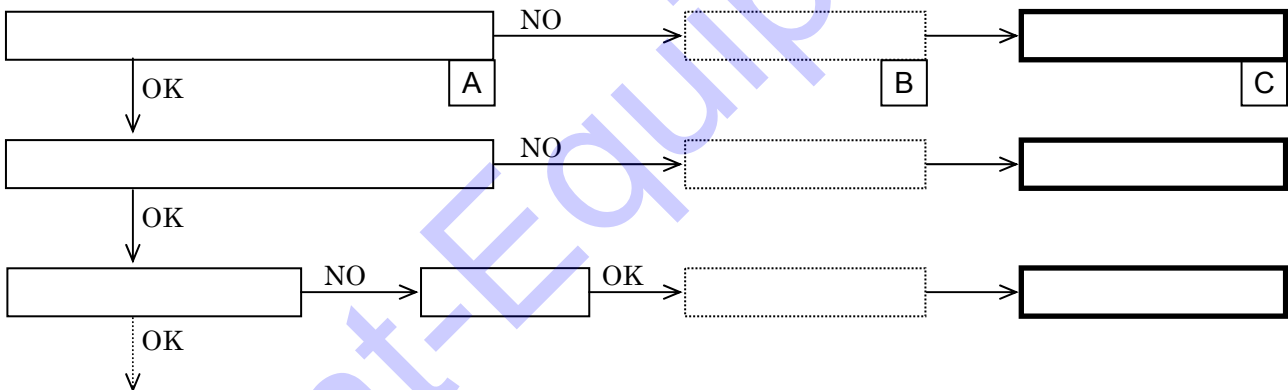

- ① In the troubleshooting column something abnormal is mentioned in lined parenthesis.



- ② In the troubleshooting column the cause of the said trouble is mentioned in dotted parenthesis.



- ③ In the troubleshooting column the countermeasures or treatment are mentioned in the double lined parenthesis.



- ④ **A** under each column means the index of explanation.
For details, see 4.5 “Explanation of Trouble Diagnosis”.

4. Troubleshooting

4.2 Failures of Compressor and Engine

4.2.1 At start-up, starter rotates slowly

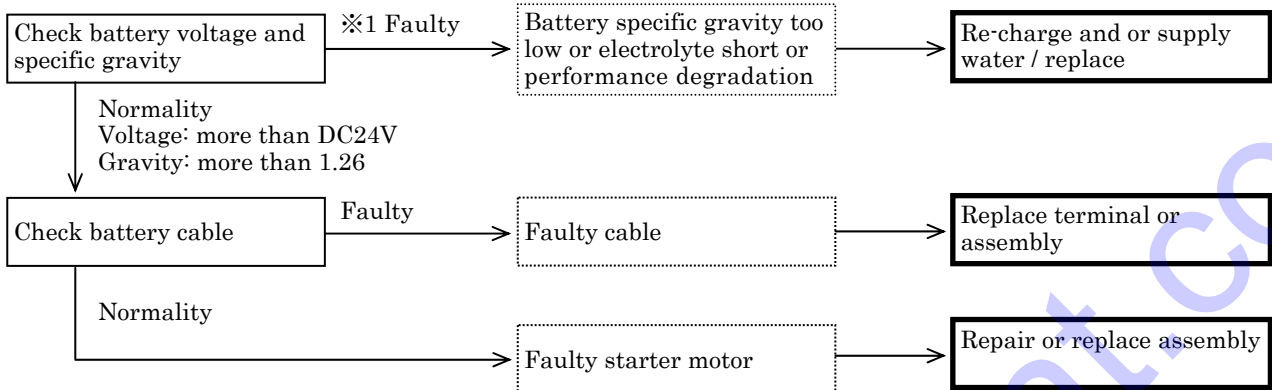

※1 : When starter switch is placed at the “START” position, the battery is not normal if B terminal voltage decreases by 20V.

4.2.2 Starter turns, but engine will not start

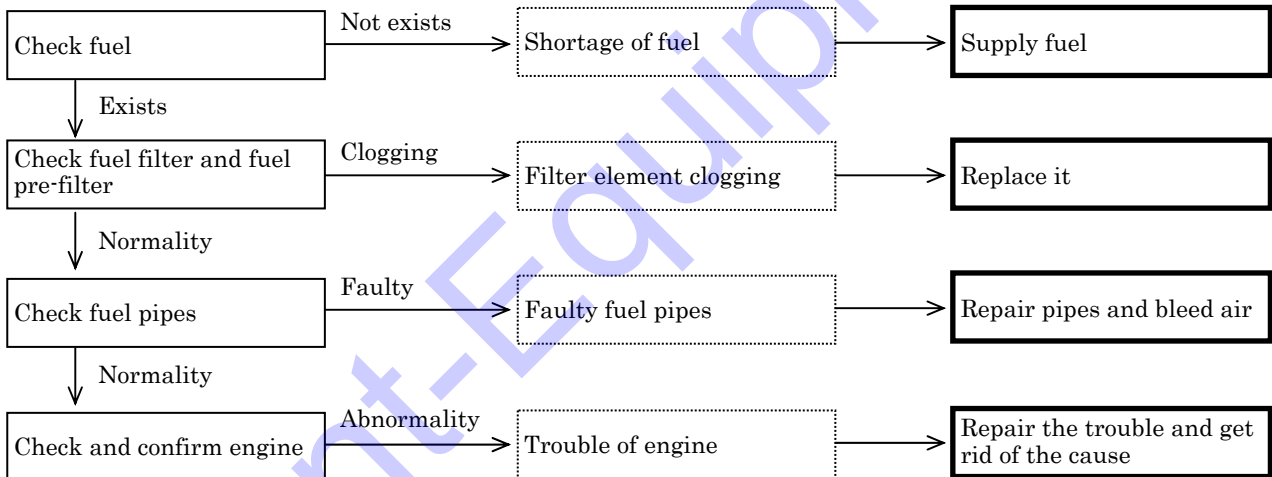

4.2.3 Engine will not turn to meet rated pressure

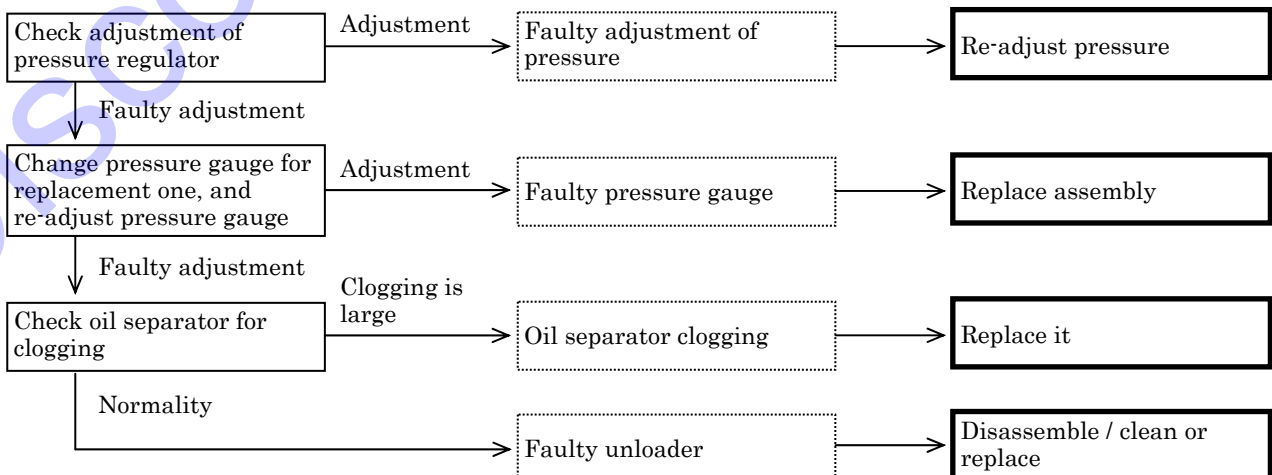

A

4. Troubleshooting

4.2.4 Engine revolutions will drop before rises up to rated pressure

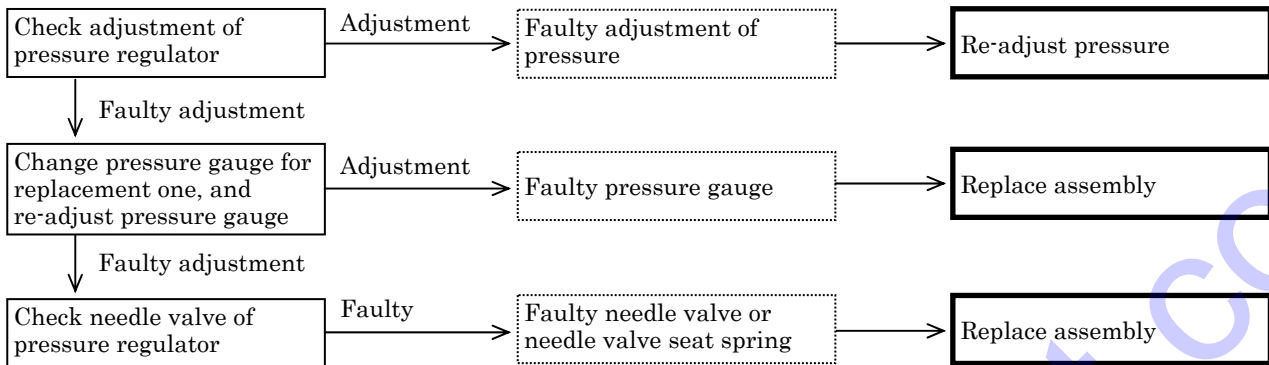

4.2.5 Engine will not turn to meet rated revolutions

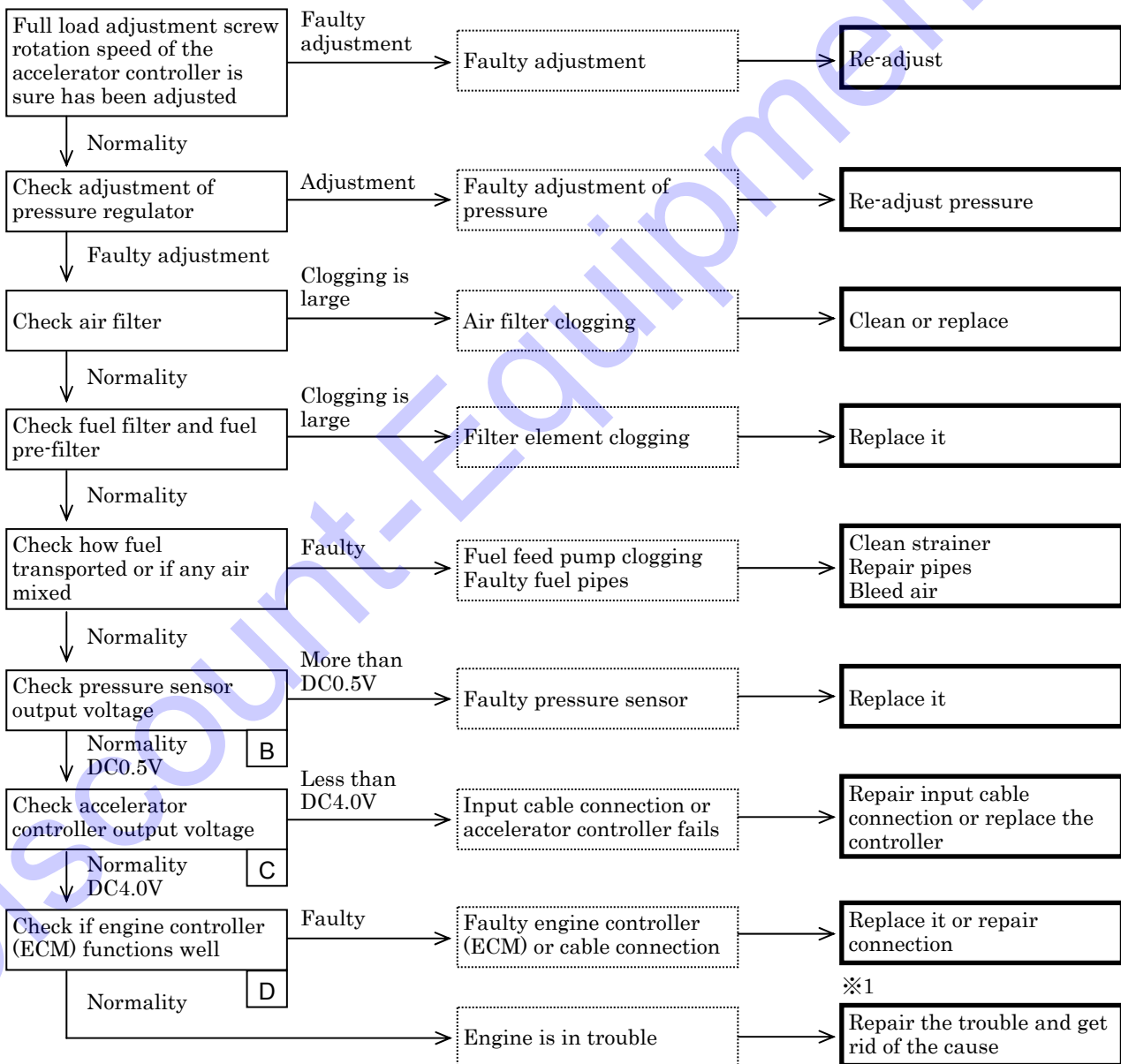

※1: For the detailed countermeasures, refer to “Troubleshooting manual”, “Workshop manual” published by engine manufacturer.

4. Troubleshooting

4.2.6 Minimum speed not available even upon no-load operation

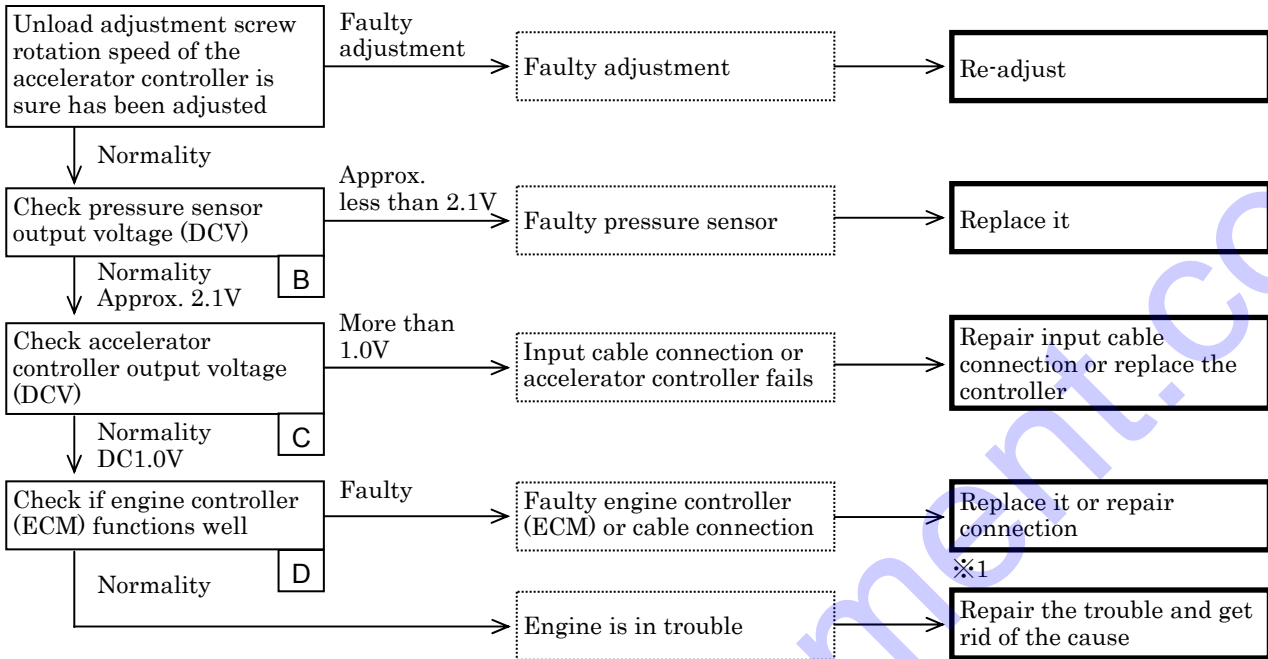

※1: For the detailed countermeasures, refer to “Troubleshooting manual”, “Workshop manual” published by engine manufacturer.

4.2.7 Safety valve bursts out during unloaded operation

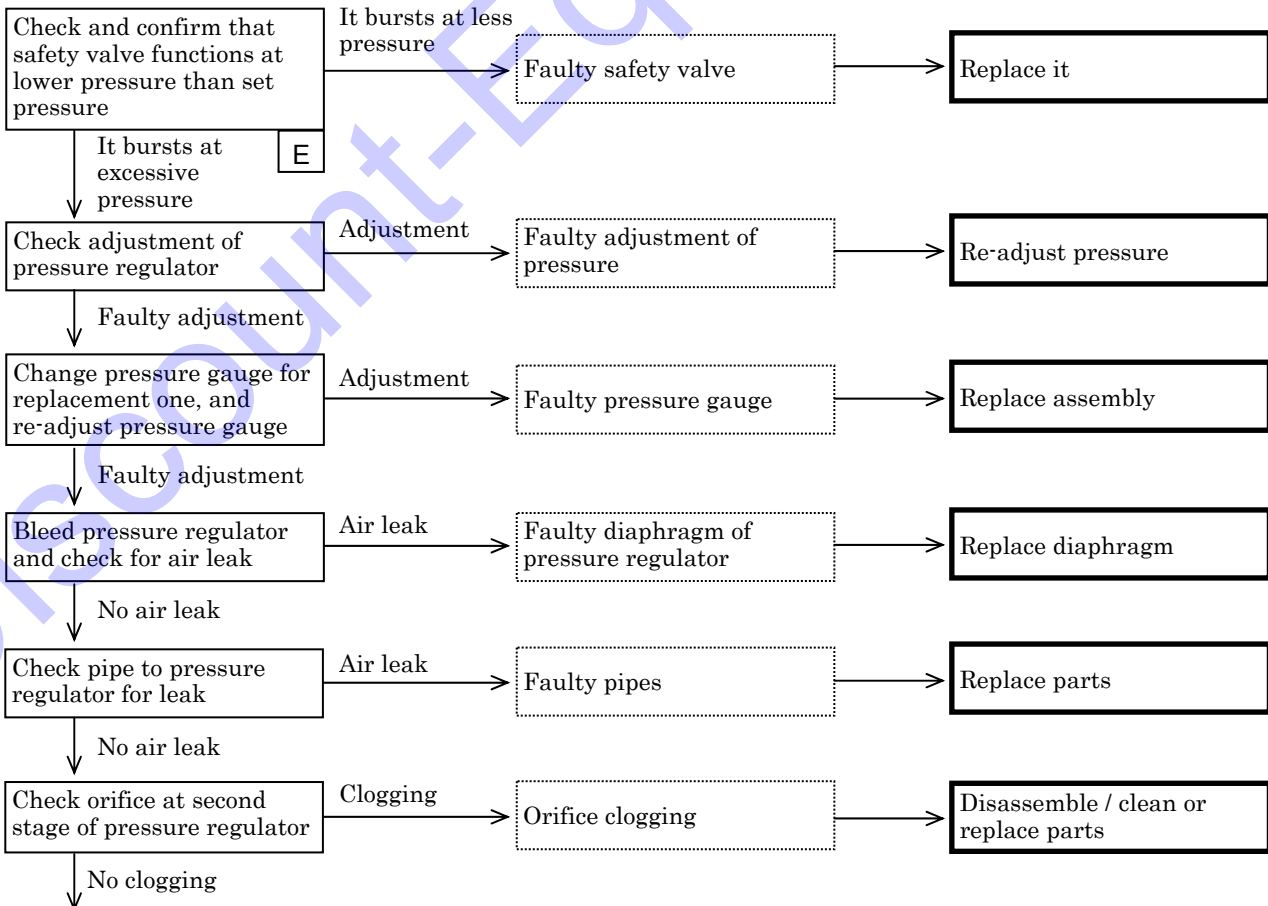

4. Troubleshooting

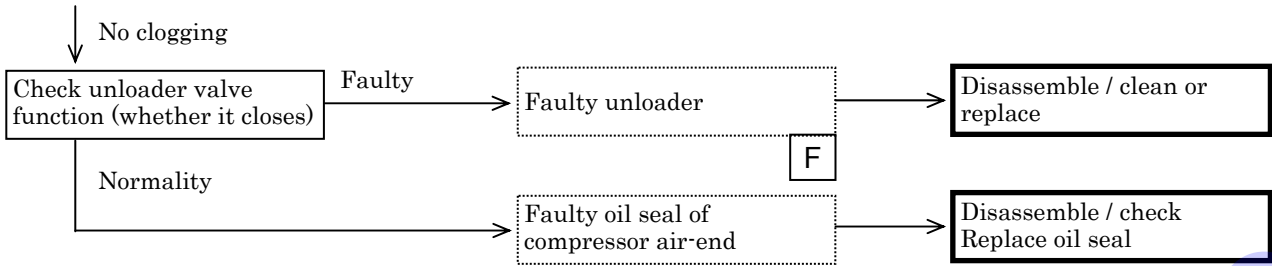

4.2.8 Oil mixed found in delivery air

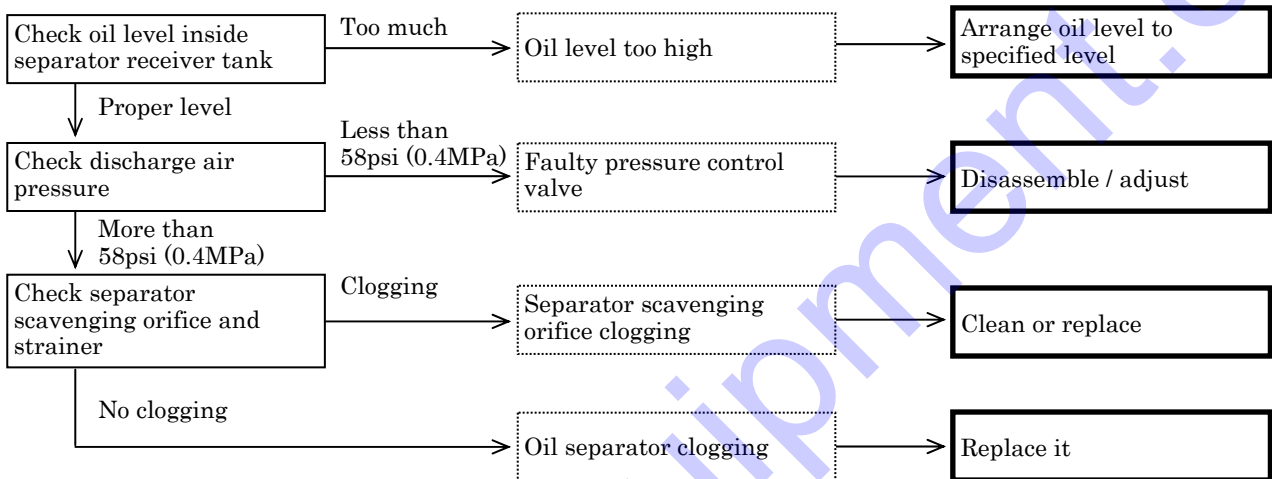

4.2.9 Water found mixed in discharge air (Aftercooler type)

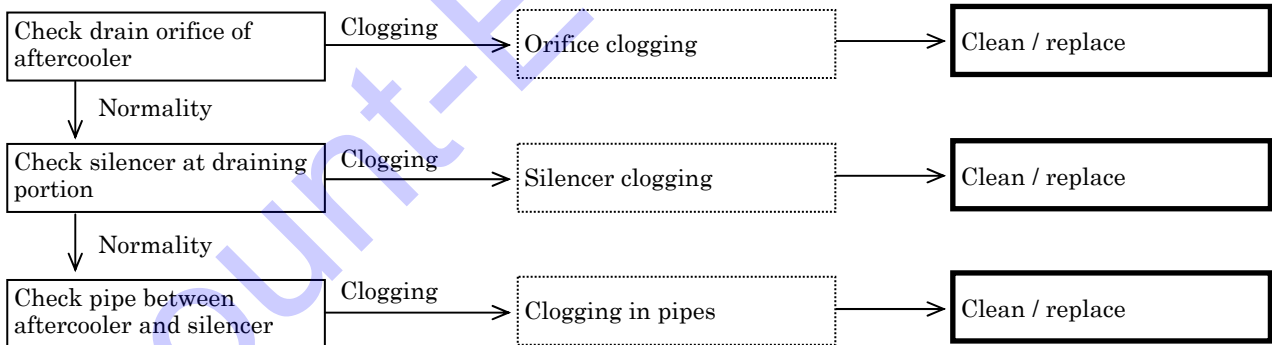

4. Troubleshooting

4.2.10 Discharge air is insufficient

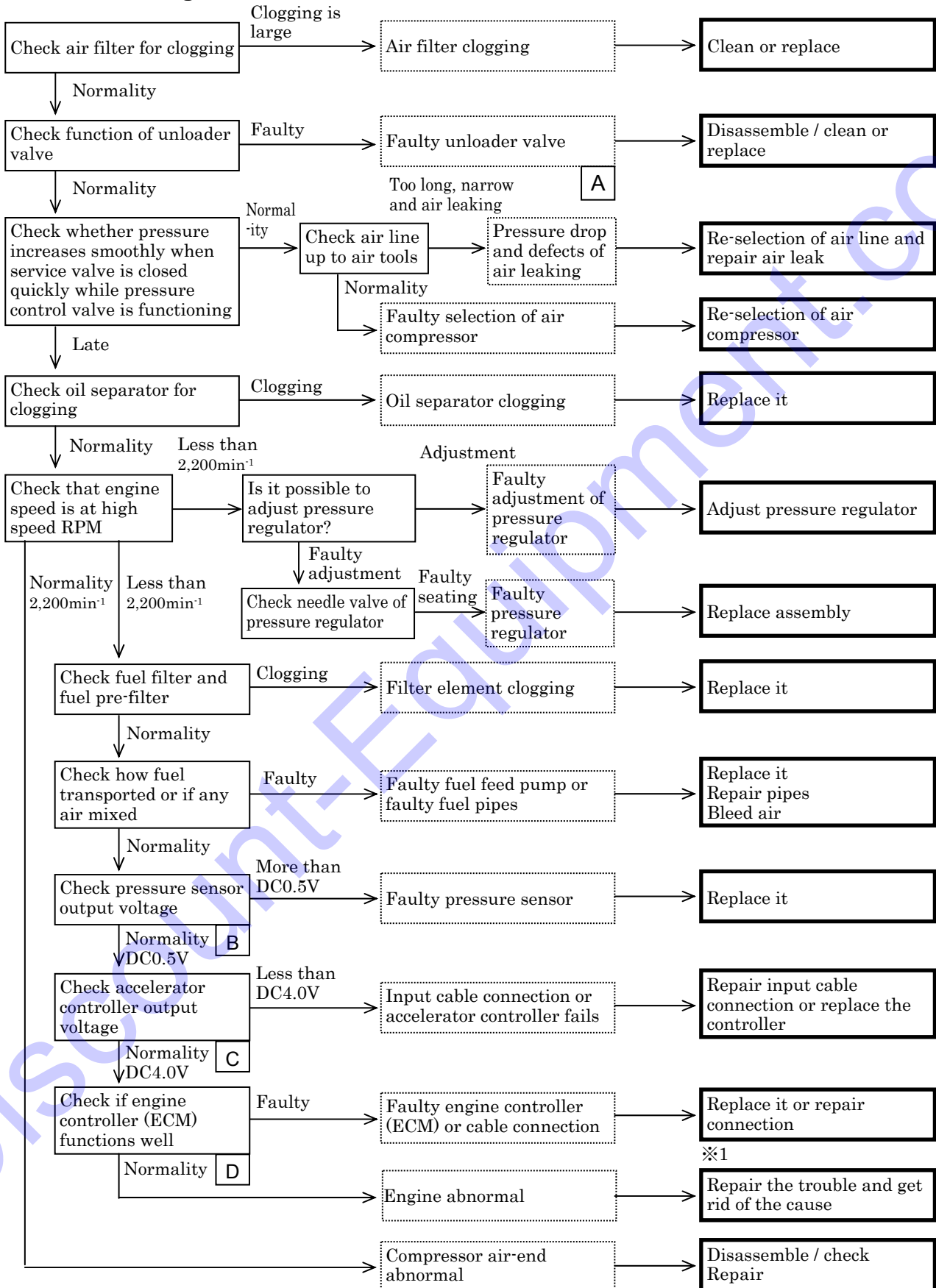

※1: For the detailed countermeasures, refer to “Troubleshooting manual”, “Workshop manual” published by engine manufacturer.

4. Troubleshooting

4.3 Operation of Emergency Switch

4.3.1 Discharge air temperature (or separator air temperature) is displayed abnormality-code and engine will stop

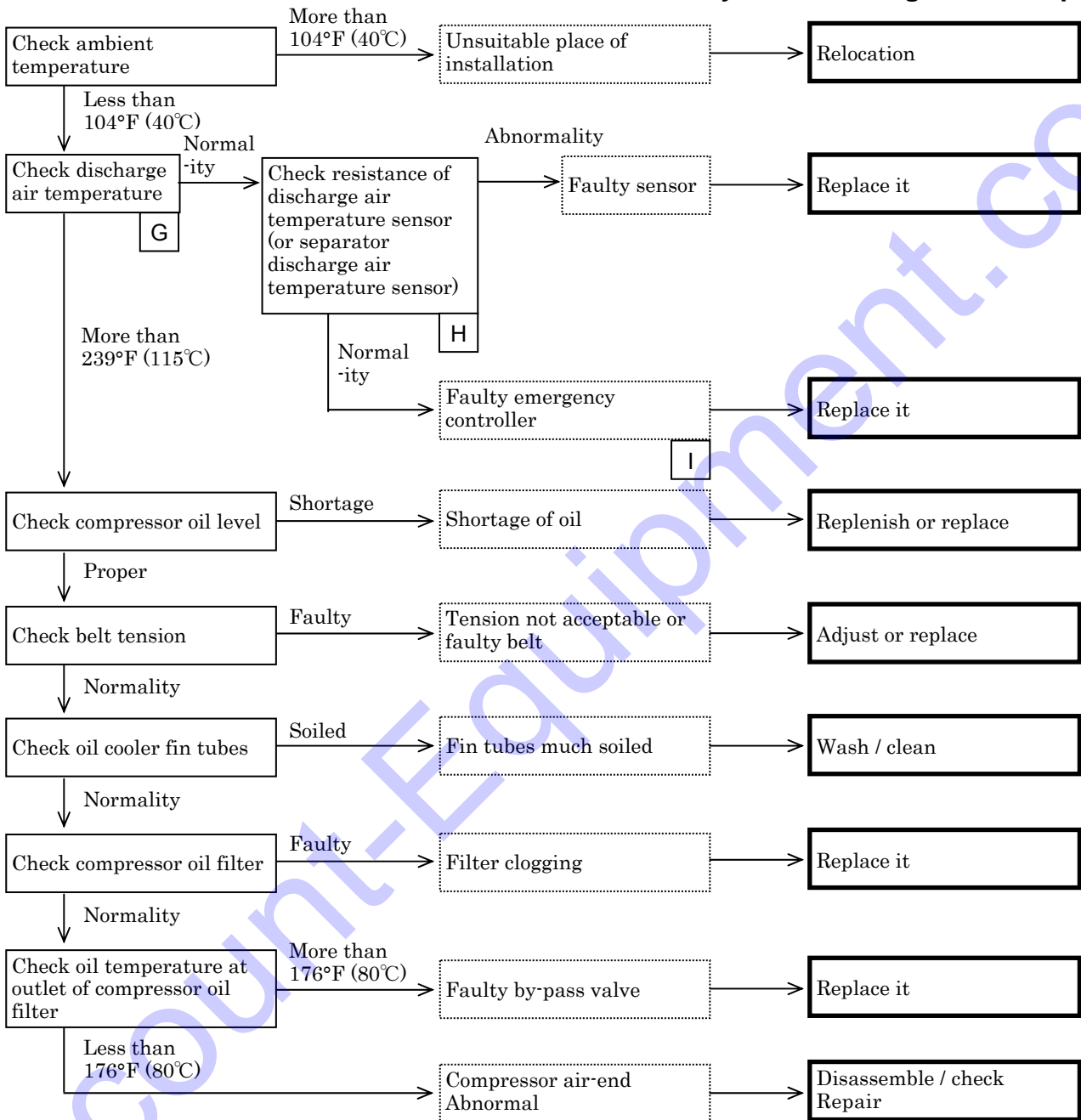

4. Troubleshooting

4.3.2 Engine oil pressure is displayed abnormality-code and engine will stop

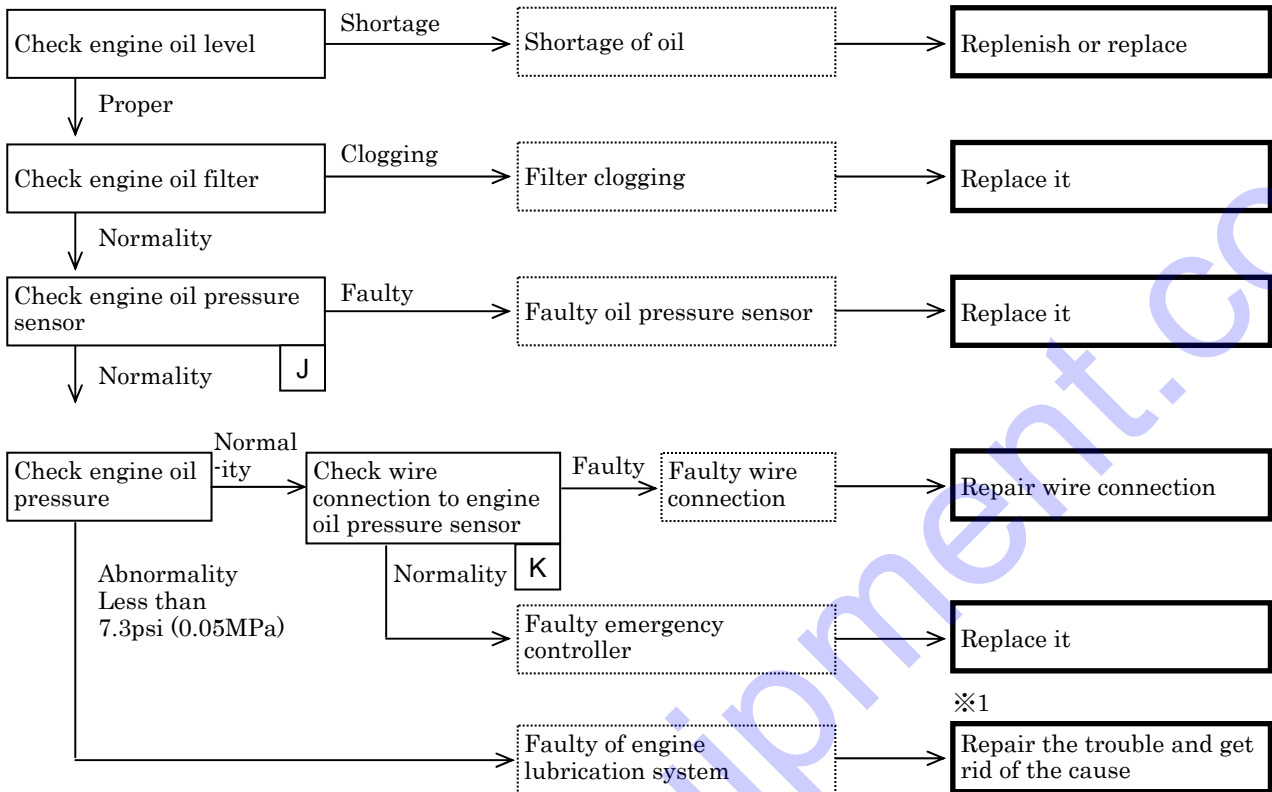

※1: For the detailed countermeasures, refer to “Troubleshooting manual”, “Workshop manual” published by engine manufacturer.

4. Troubleshooting

4.3.3 Engine coolant temperature is displayed abnormality-code and engine will stop

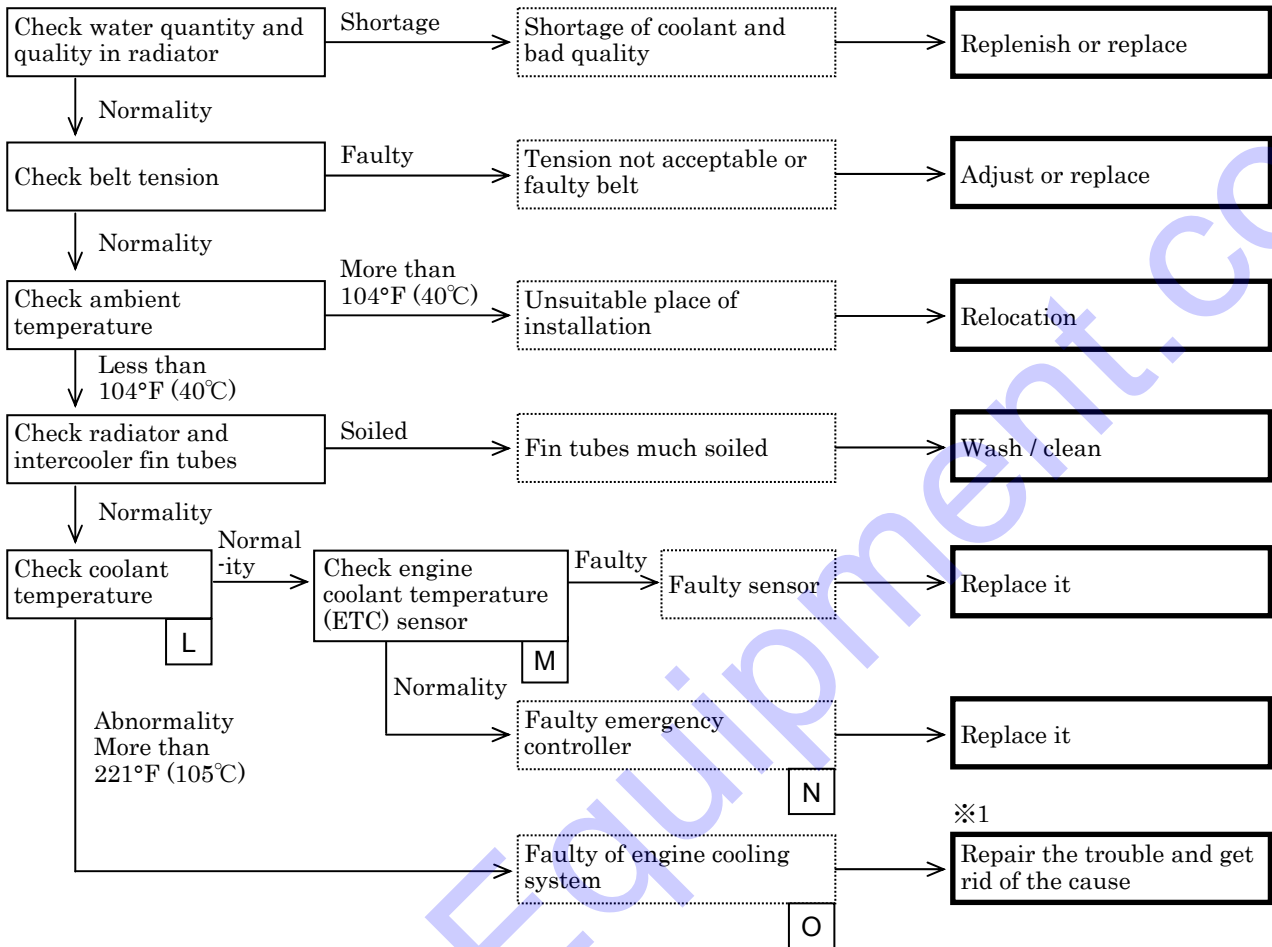

※1: For the detailed countermeasures, refer to “Troubleshooting manual”, “Workshop manual” published by engine manufacturer.

4.3.4 Engine RPM drop is displayed abnormality-code and engine will stop

Operation at the resonance rotational speed range.
Less than $1,200\text{min}^{-1}$

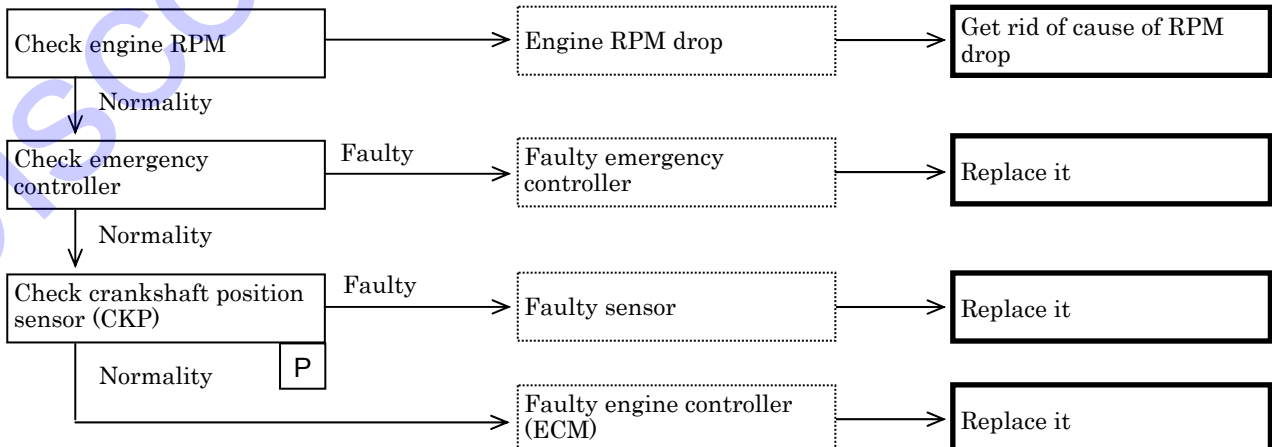

4. Troubleshooting

4.4 Others

4.4.1 Abnormality-code is not shown, engine will stop

(Starter switch is not set in contact, primary circuit of main relay (MR) is not connected properly, and blown fuse trouble is exempted)

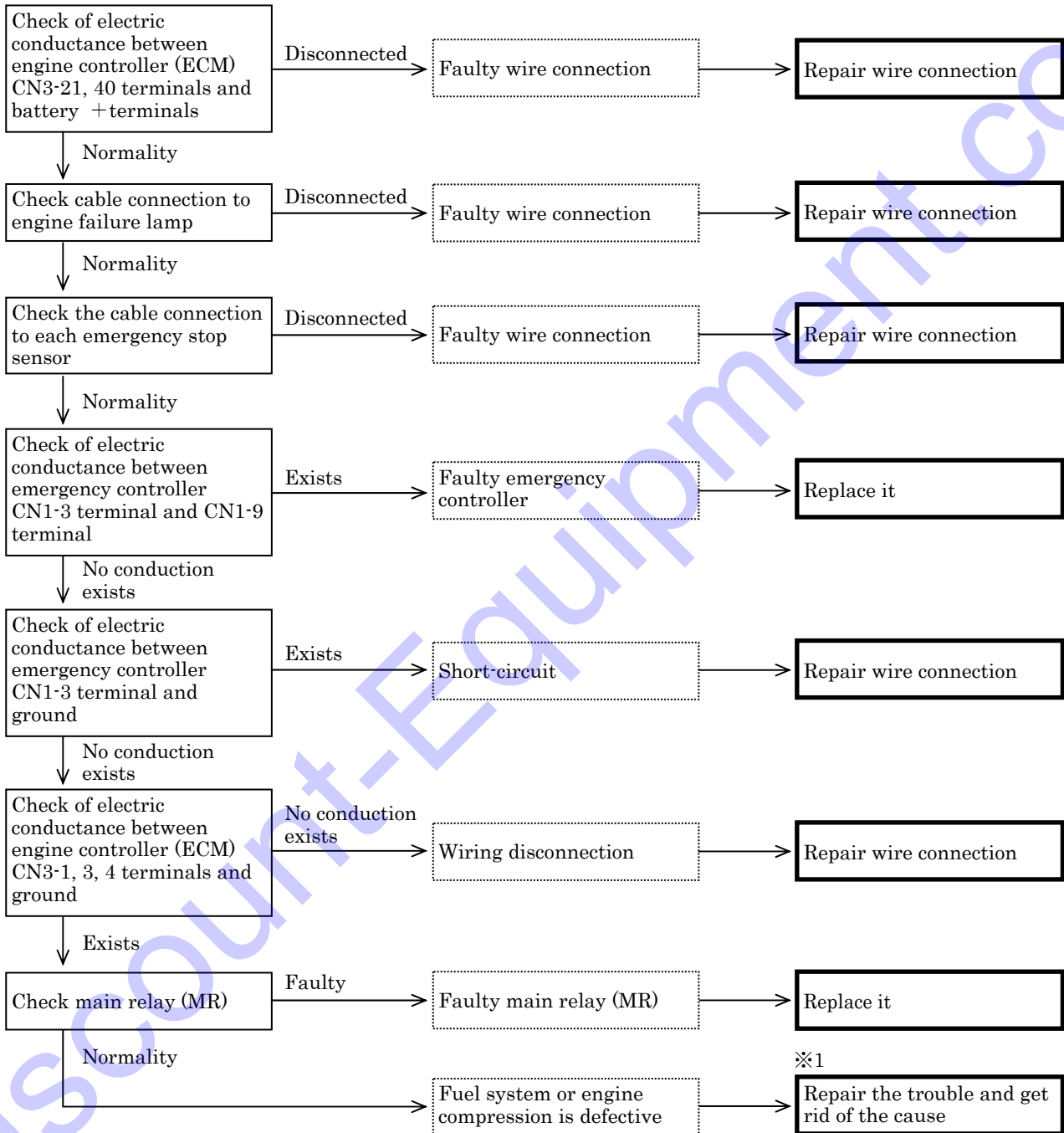

※1: For the detailed countermeasures, refer to “Troubleshooting manual”, “Workshop manual” published by engine manufacturer.

4. Troubleshooting

4.5 Explanation of Trouble Diagnosis

No.	Item	Cause	Remedy
A	Faulty unloader	Unloader valve cannot be open.	Remove unloader assembly from compressor air-end, and disassemble it for inspection and replace O-ring.
B	Check pressure sensor output voltage	Engine speed is controlled by the proper speed finally outputted to electro-control fuel injection system in the following flows after pressure sensor detects second stage pressure of regulator. Therefore, when abnormality is found in rotational speed, it is necessary that pressure sensor, emergency controller, engine controller (ECM) and related wires should be checked and confirmed whether they are disconnected and/or short-circuited.	Check output voltage (DCV) referring to “3.2 Accelerator Controller” and “3.9 Pressure Sensor”.
C	Check accelerator controller output voltage		
D	Check if engine controller (ECM) functions well	<div style="text-align: center;"> <div style="border: 1px dashed black; padding: 2px; display: inline-block;">Pressure sensor</div> ↓ Output voltage <div style="border: 1px dashed black; padding: 2px; display: inline-block;">Accelerator controller</div> ↓ Output voltage <div style="border: 1px dashed black; padding: 2px; display: inline-block;">Engine controller (ECM)</div> ↓ (Control signal) <div style="border: 1px dashed black; padding: 2px; display: inline-block;">Electronic control fuel injection system</div> </div>	Check and confirm in accordance with the “4.6 Engine Trouble Diagnosis Function”.
E	Check and confirm that safety valve functions at lower pressure than set pressure	Check and locate pressure maladjustment or defective safety valve.	In case of malfunction of safety valve, safety valve should be replaced.
F	Faulty unloader	Faulty seat of unloader valve or faulty function of unloader piston.	Remove unloader assembly from compressor air-end, and disassemble it for inspection and replace O-ring.
G	Check discharge air temperature	Check whether actual rise of discharge air temperature stops engine or any failure of electrical circuit stops engine.	
H	Check resistance of discharge air temperature / separator air temperature sensor	For temperature and resistance characteristics of discharge air temperature and separator discharge air temperature sensor, See page 3.29.	Even disconnection of sensor or its short-circuit causes engine to stop.
I	Check of electric conductance between emergency controller CN2-9 terminal and ground (or between CN2-10 terminal and ground)	In case that no electrical conductance exists, engine will stop with controller disconnection detecting function 20 seconds after engine starts. In case of short-circuit, engine will be brought to emergency stop.	Repair disconnection and short-circuit.

4. Troubleshooting

No.	Item	Cause	Remedy
J	Check engine oil pressure sensor	Oil pressure sensor detects voltage signal which engine oil pressure is converted to and transmitted to engine controller (ECM) → emergency controller.	Check and confirm in accordance with the “4.6 Engine Trouble Diagnosis Function”.
K	Check for any defective connection	Check and make sure that no disconnection has been found for oil pressure sensor.	Repair disconnection.
L	Check engine coolant temperature by monitor	Find out whether actually engine stops owing to rise of coolant temperature or owing to defect of electric circuit. Detect coolant temperature in monitor by water temperature sensor. Which is provided by Hokuetsu Industries Co., Ltd.	Check and confirm in accordance with the “4.6 Engine Trouble Diagnosis Function”.
M	Check engine coolant temperature (ETC) sensor	Engine coolant temperature (ETC) sensor is detect by converting into voltage signal changes the resistance of the temperature at the thermistor. Engine maker supply parts.	<ul style="list-style-type: none"> • Check and confirm in accordance with the “4.6 Engine Trouble Diagnosis Function”. • Even disconnection of sensor or its short-circuit causes engine to stop.
N	Check and confirm that DC voltage exists between emergency controller CN2-14 terminal and ground	If power exists between emergency controller CN1-3 and grounding, though no power exists between emergency controller CN2-14 terminal, the emergency controller is possibly defective.	Replace emergency controller.
O	Faulty of engine cooling system	When any trouble is not found in thermostat, coolant pump can be in disorder.	For the temperature at which thermostat valve opens, refer to page 2-15.
P	Check crankshaft position sensor (CKP)	Engine speed can be detected being based on the pulse (4 pulses/1 revolution) and it is used for fuel injection control. However it is done, based on CMP signal if the crankshaft position (CKP) sensor is faulty.	Check and confirm in accordance with the “4.6 Engine Trouble Diagnosis Function”.

4. Troubleshooting

4.6 Engine Trouble Diagnosis Function

With regard to this electronic governor engine (Common rail electronic control fuel injection engine), this engine itself is equipped with trouble diagnosis function. When it is in trouble, it is possible to check and confirm how the trouble is by monitor lamp blinking pattern (flash code).

4.6.1 Engine trouble diagnosis

1. Check and confirmation of trouble

When engine fails, diagnosis lamp “1” on monitor panel lights. For the details of the trouble, press diagnosis switch “2” and then it displays trouble conditions with blinking pattern (flash code).

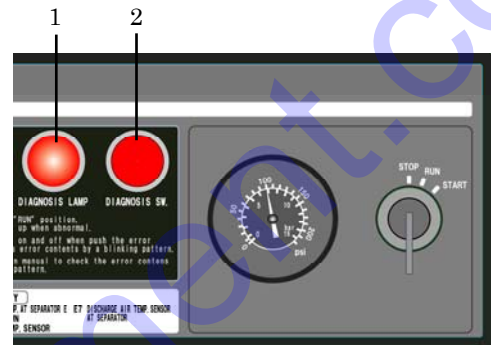

A120184

<Procedure>

- ① Turn starter switch to “RUN” position and continue pressing diagnosis switch “2” .
- ② When engine is in trouble, it displays trouble conditions with blinking patterns (flash code) of the diagnosis lamp “1” while diagnosis switch is pressed.

[Example of blinking pattern (Flash code)]

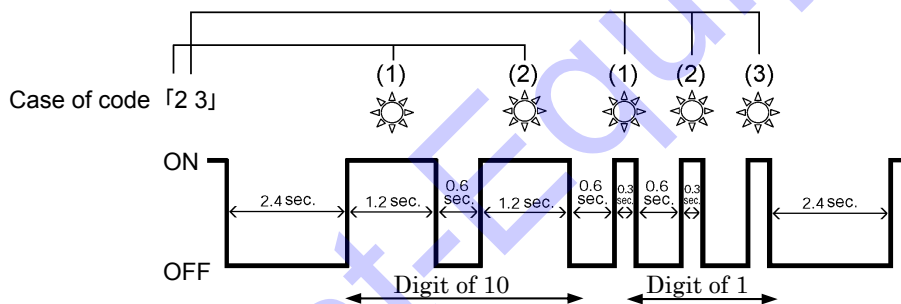

Long interval blinking 2 times and short interval blinking 3 times mean blinking pattern (flash code) 「23」.

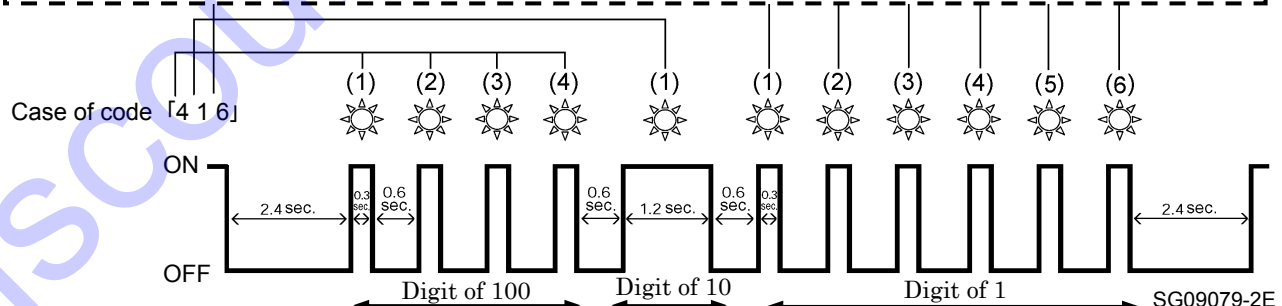

Short interval blinking 4 times and long interval blinking 1 time and short interval blinking 6 times mean blinking pattern (flash code) 「416」.

Long interval blinking : approx. 1.2 seconds Short interval blinking : approx. 0.3 seconds

4. Troubleshooting

2. Display of diagnostic trouble code (DTC) by diagnosis lamp

Only when diagnostic trouble code (DTC) occurs during engine operation, diagnosis lamp is ON. During engine stop, diagnostic trouble code (DTC) displays both present and past diagnostic trouble code (DTC) by diagnosis lamp blinking pattern (flash code).

3. In case that past diagnostic trouble code (DTC) is memorized

It displays three times memorized trouble code. In case that more than two trouble codes are memorized, it displays them three times each in numerical order. After they are displayed in one round, they are displayed in numerical order again. This display continues while diagnosis switch is being pressed.

4. In case that no diagnostic trouble code (DTC) is memorized

While you pressing diagnosis switch, diagnosis lamp - repeat continuously “the lighting 0.3 seconds 2.4 seconds off”.

5. Reading diagnostic trouble code (DTC) by diagnosis tool

It is possible to read diagnostic trouble code (DTC), using diagnosis tool.

6. List of blinking patterns (Flash codes)

Blinking pattern	Details	Item to be detected
14	Cam sensor fault (no signal)	Open circuit in sensor/wiring
	Cam sensor fault (signal fault)	Broken tooth/unnecessary signal mixed (such as short circuit with other wiring)
15	Crank sensor fault (no signal)	Open circuit in sensor/wiring
	Crank sensor fault (signal fault)	Broken tooth/unnecessary signal mixed (such as short circuit with other wiring)
16	Cam sensor out of phase	Camshaft gear/crankshaft gear installing angle is out of phase, or damage in gear
19	Starter cut relay fault	Starter cut relay fault
22	Intake air temperature sensor fault (low voltage fault)	Short circuit in sensor or harness
	Intake air temperature sensor fault (high voltage fault)	Open/short circuit/deterioration of sensor or harness
23	Engine coolant temperature sensor fault (low voltage fault)	Short circuit in sensor or harness
	Engine coolant temperature sensor fault (high voltage fault)	Open/short circuit/breakage of sensor or harness
24	Accelerator sensor 1-2 comparison fault	Opening degree difference between the accelerator sensor 1-2 45% or more
	Accelerator sensor 1 fault (low voltage fault)	Open/short circuit/breakage of sensor or harness
	Accelerator sensor 1 fault (high voltage fault)	Open/short circuit/breakage of sensor or harness
	Accelerator sensor 2 fault (low voltage fault)	Open/short circuit/breakage of sensor or harness
	Accelerator sensor 2 fault (high voltage fault)	Open/short circuit/breakage of sensor or harness
32	Boost pressure sensor fault (high voltage fault)	Short circuit in sensor or harness

4. Troubleshooting

Blinking pattern	Details	Item to be detected
34	Charge circuit fault (bank 1)	ECU charge circuit 1 fault (internal burnout, open circuit, etc.)
	Charge circuit fault (bank 2)	ECU charge circuit 2 fault (internal burnout, open circuit, etc.)
36	A/D conversion fault	A/D conversion fault
44	EGR position fault (Brushless specification)	Open/short circuit/breakage of sensor or harness
45	EGR valve control fault	Trouble/open circuit or valve engage/stuck drive motor side
51	CPU fault	CPU fault
52	CPU monitoring IC fault	Sub-CPU fault
53	ROM fault	ROM fault
54	EEPROM fault	EEPROM fault
55	Voltage fault in 5V power supply 1	Power supply wiring short to sensor, or breakage in element/circuit for power supply regulation inside ECM
	Voltage fault in 5V power supply 2	
	Voltage fault in 5V power supply 3	
	Voltage fault in 5V power supply 4	
	Voltage fault in 5V power supply 5	
66	Glow relay fault	Open/short circuit/damage of relay or harness
71	Barometric pressure sensor fault (low voltage fault)	Open/short circuit/deterioration of sensor or harness
	Barometric pressure sensor fault (high voltage fault)	Short circuit in sensor or harness
77	Check engine lamp fault	Lamp fault
84	CAN-Bus fault	CAN communication fault
85	CAN-time out fault	CAN communication fault
118	Common rail pressure fault (1st stage)	Common rail pressure abnormal increase
	Common rail pressure fault (2nd stage)	
151	Common rail pressure fault (Excessive pressure feed in pump)	Common rail pressure abnormal increase
158	Injection nozzle common 1 drive system fault	Open/short circuit in injection common 1-side electrical wiring, EDU output part fault
159	Injection nozzle common 2 drive system fault	Open/short circuit in injection common 2-side electrical wiring, EDU output part fault
211	Fuel temperature sensor fault (low voltage fault)	Short circuit in sensor or harness
	Fuel temperature sensor fault (high voltage fault)	Open/short circuit/breakage of sensor or harness
225	Pressure limiter open	Pressure limiter is opened
227	No pump pressure feed (fuel leakage)	Common rail pressure does not increase to the required area
	No pump pressure feed (fuel leakage)	Fuel leakage (large amount)
245	Common rail pressure sensor fault (low voltage fault)	Short circuit in sensor or harness
	Common rail pressure sensor fault (high voltage fault)	Open/short circuit/breakage of sensor or harness
247	SCV drive system open circuit, +B short or ground short	Open/short circuit of SCV/harness
271	Open circuit injection nozzle #1 drive system	Open/short circuit in electrical wiring No.1 cylinder injection
272	Open circuit injection nozzle #2 drive system	Open/short circuit in electrical wiring No.2 cylinder injection

4. Troubleshooting

Blinking pattern	Details	Item to be detected
273	Open circuit injection nozzle #3 drive system	Open/short circuit in electrical wiring No.3 cylinder injection
274	Open circuit injection nozzle #4 drive system	Open/short circuit in electrical wiring No.4 cylinder injection
294	Engine oil pressure sensor fault (low voltage fault)	Open/short circuit/breakage of sensor or harness
	Engine oil pressure sensor fault (high voltage fault)	Short circuit in sensor or harness
295	Boost temperature sensor fault (low voltage fault)	Open/short circuit/breakage of sensor or harness
	Boost temperature sensor fault (high voltage fault)	Short circuit in sensor or harness
416	Main relay system fault (Not enter)	Open/ground short circuit in harness, relay OFF anchoring
	Main relay system fault (Not enter)	Harness +B short, relay ON anchoring
542	Overheat	Overheat condition
543	Overrun	Engine speed abnormally high

7. Necessary measures for the results of diagnosis trouble

See list of blinking patterns (flash codes) and results of diagnosis trouble mentioned on previous pages. For the detailed countermeasures, refer to “Troubleshooting manual”, “Service manual” published by Isuzu Motors. (If scan tool is fitted, it is possible to check or read troubles by scan tool operation.)

Take special care in handling fuel system, and so refer to the following cautions.

<Fuel pipes>

- Never use such pipes as used high pressure pipes of fuel system and injector pipes. Make sure to replace used ones by new ones.
- Never change pressure limiter, common rail pressure sensor only. If they are in trouble, change it as an assembly and all fuel pipes.

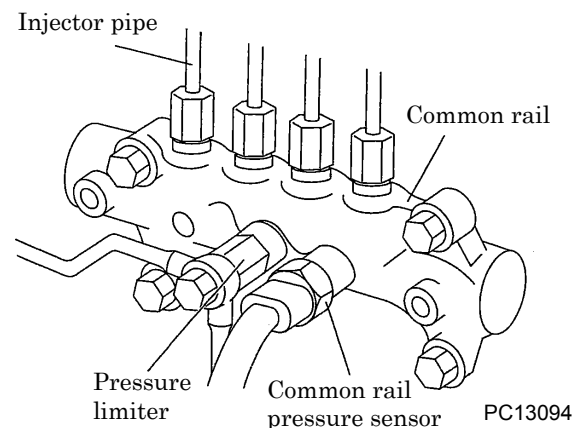

[Cautions about maintenance of fuel system]

- All the parts of fuel system and holes/clearances as fuel passage are precision-machined so that entrance of foreign matters affects so badly them to cause damages to fuel passage. Therefore, you should take special care to prevent them to enter fuel system.
Before preparing maintenance work, wash your hands and never use working gloves for this job.
- If you remove high pressure pipes in fuel system, make sure to replace them by new ones. If you re-use them, it could damage sealing face and cause fuel leakage.
Make sure to replace spare parts such as gasket and O-ring by new ones.

4. Troubleshooting

4.6.2 How to delete diagnostic trouble code (DTC)

1. Deletion of diagnostic trouble code (DTC)

When diagnostic trouble code (DTC) is memorized in engine control module (ECM) in case of system trouble. Even after troubled parts have been repaired, memory of diagnostic trouble code (DTC) will not be deleted in this case. It is necessary to compulsorily delete this memory, according to the following procedures.

2. Memory clear

① Switch ON starter switch.

② Switch ON diagnosis switch of the monitor panel.

Diagnosis switch to maintain is ON by momentary type, press and hold.

③ Switch ON memory clear switch (connection of ECM CN3-32 terminal and ground connection).

To ground : 0.75G terminal (female terminal) of engine controller (ECM) of the operation panel inside.

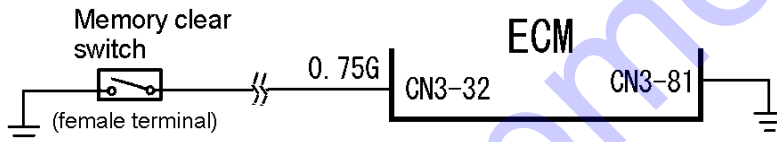

PC12061E

Female terminal Engine controller (ECM)



PC14070

④ Wait for more than 3 seconds in the ON.

⑤ Switch OFF memory clear switch (connection of ECM CN3-32 terminal and ground connection).

⑥ Switch OFF diagnosis switch.

⑦ Switch OFF starter switch.

⑧ Wait for 10 seconds with the switches OFF.

⑨ Switch ON starter switch.

⑩ Switch ON diagnosis switch.

⑪ Check and confirm that memories are deleted.

5. References

5.1 Consumable Parts and Electrical Appliances

Item	Parts No.
●Element / Filter / Belt	
Air filter ASS'Y (For compressor)	32100 39700
Air filter element	32143 12500
Air filter ASS'Y (For engine)	32100 41001
Air filter element	32143 12700
Oil separator	34220 16500
Gasket for oil separator	34235 06000 34235 06100
Gasket for piping	35424 05801
Compressor oil filter ASS'Y	37400 13700
Oil filter cartridge	37438 05601
Drain separator ASS'Y	34200 03201
O-ring	38911 01300
Engine oil filter ASS'Y	—
Oil filter element	37438 08700 (Isuzu part number:898018-8580)
Fuel filter ASS'Y	Isuzu part number:898143-8260
Fuel filter element	43543 01000 (Isuzu part number:898143-0410)
Fuel pre-filter ASS'Y	Isuzu part number:898075-8552
Fuel pre-filter element	43543 00900 (Isuzu part number:898074-2880)
Fuel air-bleeding electromagnetic pump repair kit	Isuzu part number:898173-1650
Gasket for engine feed pump joint	Isuzu part number:109630-0850×3
Copper packing for air-bleeding plug of the EGR cooler	Isuzu part number:909571-4100
Belt	Isuzu part number:898038-8560
●Air control	
Pressure regulator ASS'Y	36400 19000
Auto-relief valve / Vacuum relief valve ASS'Y	36600 03502
O-ring	21221 02100×2
O-ring	03402 25021×2
O-ring	03402 25008×2
Pressure control valve ASS'Y	35300 17600
O-ring	03402 25048
O-ring	21441 03700
Ring	22505 03300
Spring	35304 03000
Piston	35303 10500
Unloader ASS'Y	22100 41900
O-ring	21441 03800
O-ring	21441 03400
Gasket	22116 02400
Gasket	22112 08800

5. References

Item	Parts No.
●Instruments on panel	
Starter switch	44322 02800
Pressure gauge	36141 18600 (Isuzu part number:894402-5000)
Engine diagnosis switch	46242 21800
Engine diagnosis lamp	46161 13700
●Oil line	
By-pass valve ASS'Y	37200 11502
Pellet	37231 02100
O-ring	03402 25045
O-ring	03402 15025
O-ring	03402 15045
●Electrical appliances	
Engine controller (ECM)	44390 03700 (Isuzu part number:898201-3040)
Accelerator controller	46870 54900
Emergency controller	46870 56600
Main relay (MR)	44324 05800 (Isuzu part number:898013-7900)
Safety relay (SR)	44324 05800 (Isuzu part number:898013-7900)
Starter relay (SY)	44346 15600 (Isuzu part number:898005-6310)
Glow relay (GR)	44346 15500 (Isuzu part number:894460-7061)
Electromagnetic pump relay (FR)	44346 07500 (Isuzu part number:582550-0300)
Electromagnetic pump	43650 02500 (Isuzu part number:898009-3971)
Solenoid valve for starting unloader (SV1)	46811 27100
Solenoid valve for starting unloader (SV2)	46811 28700
Fuse 10A	46934 03200×2
Fuse 60A	44470 02300×2
Pressure sensor	44328 20600
Barometric pressure sensor	44328 21500 (Isuzu part number:897217-7780)
Intake air temperature sensor (IAT)	44364 06600 (Isuzu part number:812146-8300)
Engine coolant temperature sensor	44364 08200
Discharge air temperature sensor	44364 08200
Separator air temperature sensor	44364 08200
Engine oil pressure sensor	Isuzu part number:898027-4560
Engine coolant temperature sensor (ECT)	Isuzu part number:898156-6480
Sending unit	36159 02202
Air filter indicator	32148 03000×2

5.2 Engine Wiring Diagram

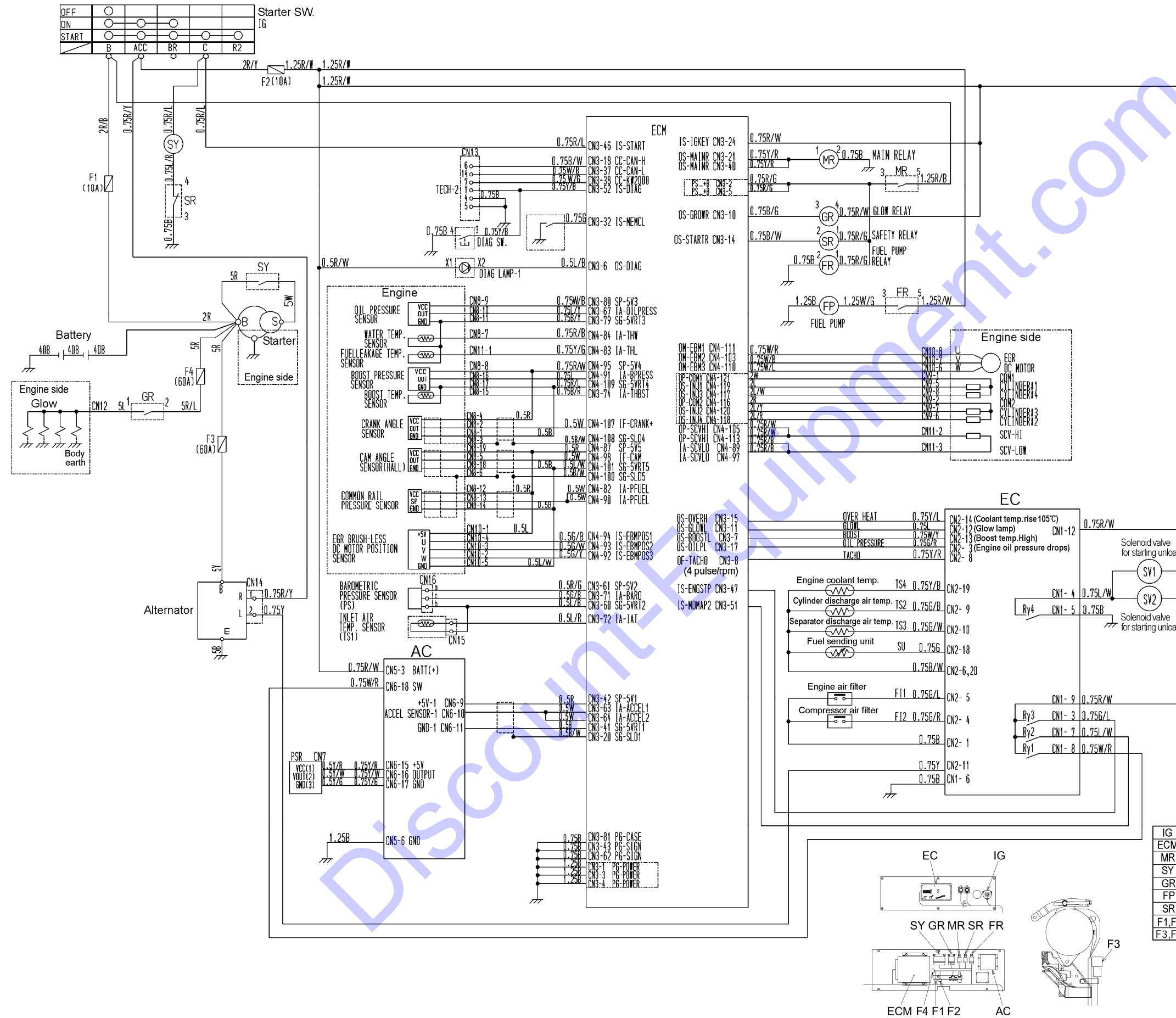

Connector terminal arrangement

The following arrangement is seen from the side of the connector inserting port.

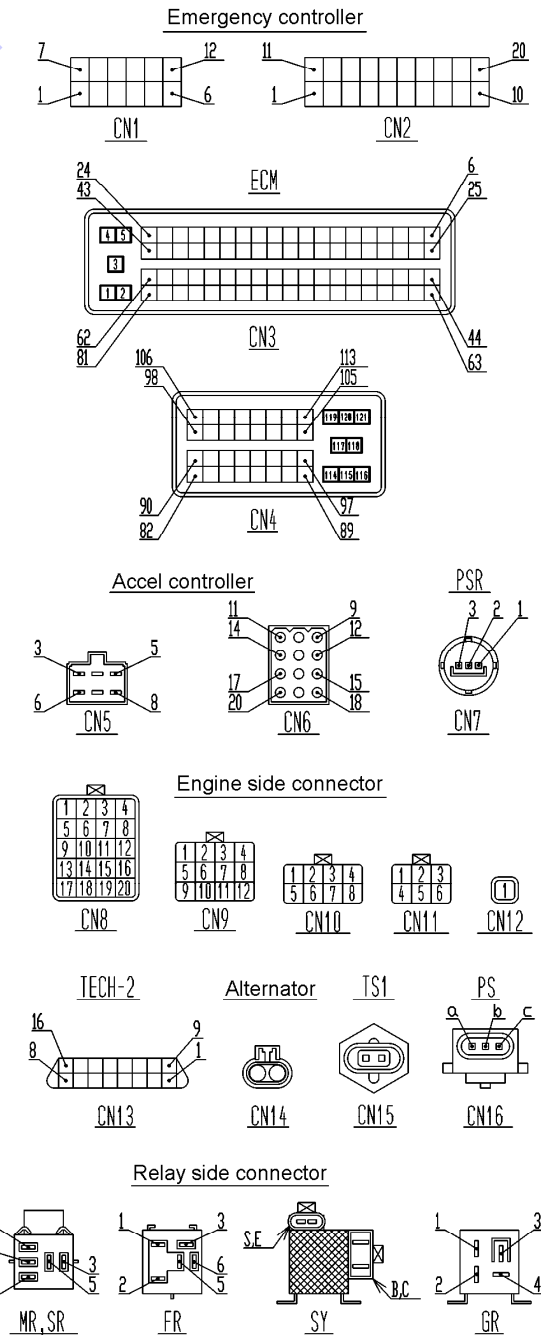

IG	Starter SW.	SV1	Solenoid valve for starting unloader
ECM	Engine controller	SV2	Solenoid valve for starting unloader
MR	Main relay	PSR	Pressure sensor
SY	Starter relay	SU	Sending unit
GR	Grow relay	F1,F12	Filter indicator
FP	Electromagnetic pump	FR	Electromagnetic pump relay
SR	Safety relay	AC	Accelerator controller
F1,F2	Fuse (10A)	EC	Emergency controller
F3,F4	Fuse (60A)		

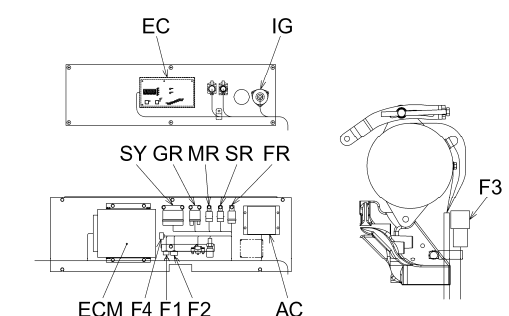

PC13088

PC13087E

This text book contains the most recent information available at the time of printing, and the contents of the list are based on information in effect at that time and are subject to change without notice.



www.discount-equipment.com

HOKUETSU INDUSTRIES CO., LTD.

Copyright(C) 2014 HOKUETSU INDUSTRIES CO., LTD. All Rights Reserved.

NPC-0099

PRINTED IN JAPAN. Dec 2014