



INSTRUCTIONAL MANUAL

AIR COMPRESSOR

PDS400S-6B1



www.discount-equipment.com

Discount Equipment

Discount-Equipment.com is your online resource for commercial and industrial quality parts and equipment sales.

Locations:

Florida (West Palm Beach): [561-964-4949](tel:561-964-4949)

Outside Florida TOLL FREE: [877-690-3101](tel:877-690-3101)

Need parts? Check out our website at www.discount-equipment.com

Can't find what you need?

Click on this link: <http://www.discount-equipment.com/category/5443-parts/> and fill out the request form.

Please have the machine model and serial number available in order to help us get you the correct parts. One of our experienced staff members will get back to you with a quote for the right part that your machine needs.

We sell worldwide for the brands: Genie, Terex, JLG, MultiQuip, Mayco, Toro/Stone, Diamond Products, Magnum, Airman, Mustang, Power Blanket, Nifty Lift, Atlas Copco, Chicago Pneumatic, Allmand Brothers, Essick, Miller Spreader, Skyjack, Lull, Skytrak, Tsurumi, Husquvarna/Target, Whiteman-Concrete/Mortar, Stow-Concrete/Mortar, Baldor, Wacker, Sakai, Snorkel, Upright, Mi-T-M, Sullair, Neal, Basic, Dynapac, MBW, Weber, Bartell, Bennar Newman, Haulotte, Ditch Runner, Blaw-Knox, Himoina, Best, Buddy, Crown, Edco, Wyco, Bomag, Laymor, Terremite, Barreto, EZ Trench, Takeuchi, Basic, Bil-Jax, Curtis, Gehl, Heli, Honda, ICS/PowerGrit, Puckett, Waldon, ASV, IHI, Partner, Imer, Clipper, MMD, Koshin, Rice, Gorman Rupp, CH&E, Cat Pumps, Comet, General Pump, Giant, AMida, Coleman, NAC, Gradall, Square Shooter, Kent, Stanley, Tamco, Toku, Hatz, Kohler, Robin, Wisconsin, Northrock, Oztec, Toker TK, Rol-Air, Small Line, Wanco, Yanmar

New Equipment - Used Equipment - Rental Equipment - Parts and Accessories

Discount Equipment

www.discount-equipment.com

561-964-4949

Parts: wbparts@Discount-Equipment.com

Sales: info@Discount-Equipment.com

Preface

This manual explains and illustrates proper handling of the unit, method of daily inspection and maintenance to enhance the performance of AIRMAN's compressors.

In order to use a machine safely, people with sufficient knowledge and sufficient technology need to deal with it.

Before operating the unit, read the manual carefully, fully understand its operation and maintenance requirement. Maintain "SAFETY OPERATION AND PROPER MAINTENANCE OF THE UNIT".

Be sure to follow safety warnings and cautions given in the manual. Unsafe operation could cause serious injury or death.

For details of handling, maintenance and safety of the engine, see the Engine Operation Manual.

Keep the manual available at all times for the operator or safety supervisor.

If the manual is lost or damaged, place an order with your dealer for another copy.

Be sure that the manual is included with the unit when it is handed over to another user.

There may be some inconsistency in detail between the manual and the actual machine due to improvements of the machine. Ask your dealer if you have any questions or problems.

If you have any questions about the unit, please inform us the model and serial number. A plate stamped with the model and serial number is attached to side of the unit.

PORTABLE COMPRESSOR	
MODEL	<input type="text"/>
SER. NO.	<input type="text"/>
NORMAL OPERATING PRESSURE	<input type="text"/> MPa
NET DRY MASS	<input type="text"/> kg
AIRMAN MADE IN JAPAN HOKUETSU INDUSTRIES CO., LTD. 22-2, NISHI-SHINJUKU 1-CHOME, SHINJUKU-KU TOKYO JAPAN	

A990054





Table of Contents

1. Safety	1-1
1.1 Caution before Operation	1-2
1.2 Caution during Operation	1-5
1.3 Caution during Inspection and Maintenance	1-7
1.4 Safety Warning Labels	1-10
2. Part Names	2-1
2.1 Unit Appearance and Part Names	2-1
2.2 Internal Components and Part Names	2-2
3. Installation	3-1
3.1 Transportation	3-1
3.2 Towing the Unit	3-2
3.3 Location and Installation	3-3
4. Operation	4-1
4.1 Instrument panel	4-1
4.2 Door	4-2
4.3 Check before Starting the Unit	4-2
4.4 Unit Operation	4-7
4.5 Stopping Procedures	4-11
5. Periodic Inspection/Maintenance	5-1
5.1 Important items as Periodic and Maintenance or after Maintenance	5-1
5.2 Daily Inspection and keeping Operation Log	5-2
5.3 Inspection on Separator Receiver Tank	5-2
5.4 Periodic Inspection List	5-3
5.5 Periodic Replacement of Parts	5-4
5.6 Maintenance	5-5
6. Maintenance/Adjustment	6-1
6.1 Maintenance of Battery	6-1
6.2 Troubleshooting	6-3
7. Storage of the Unit	7-1
7.1 Preparation for Long-term Storage	7-1
8. Specifications	8-1
8.1 Specifications	8-1
8.2 Outline drawing	8-1
9. Wiring Diagram	9-1
10. Piping Diagram	10-1

1.Safety

This manual explains and illustrates general requirements for safety.

Read all safety requirements carefully and fully understand the contents before starting the machine.

For your better recognition, according to the degree of potential danger, safety messages are classified into three hierarchical categories, namely, , , and  with a caution symbol  - attached to each message.

When one of these messages is , please take preventive measures and carry out “SAFETY OPERATION AND PROPER MAINTENANCE OF THE UNIT”.



DANGER indicates an imminently hazardous situation which, if not avoided, will result in death or serious injury. This signal word is to be limited to the most extreme situations.



WARNING indicates a potentially hazardous situation which, if not avoided, could result in death or serious injury.



CAUTION indicates a potentially hazardous situation which, if not avoided, may result in minor or moderate injury. It may also be used to alert against unsafe practices.



IMPORTANT indicates important caution messages for the performance or durability of the unit.

Follow warnings mentioned in this manual. This manual does not describe all safety items. We, therefore, advise you to pay special attention to all items (even though they may not be described in the manual) for your safety.

1. Safety

1.1 Caution before Operation

DANGER

Air pressurized construction method prohibited

- Never use the unit directly or indirectly for the following purposes:
- Never use the unit for respirator equipment by which compressed air is supplied for human consumption. The compressed air contains carbon monoxide and other contaminants, and such air may cause serious injury or even death if used by a person for respiration.
- This compressor is not designed for air pressurized construction method and underwater diving jobs. Never use compressed air for human consumption such as pressurizing diving air tanks. Consumption of compressed air can cause death while diving.

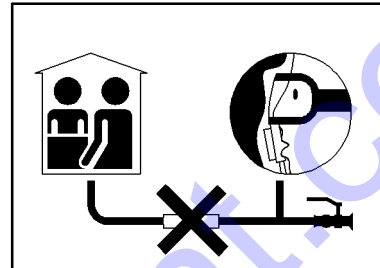

TR0201

WARNING

Follow the safety instructions

- Read each instruction plate which is displayed in the manual or on the unit carefully, understand its content and follow the indications thereof.
- Keep the Safety Warning labels clean. When they are damaged or missing, apply new ones.
- Do not modify the machine without prior approval. The safety may be compromised, functions may be deteriorated, or machine life may be shortened.
- Never use the unit for the purpose of compression of gases other than air, or as a vacuum pump. Otherwise, serious accidents may occur.

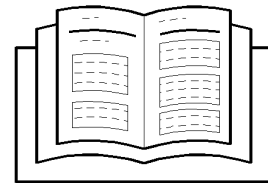

TR0086

WARNING

Ventilation

- Exhaust gas from the engine is poisonous, and could cause death when inhaled. Avoid using the machine in an insufficiently ventilated building or tunnel.

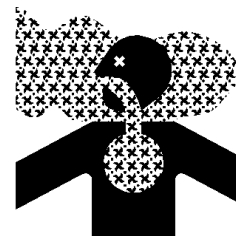

PC002

1.Safety

WARNING

Handling battery

- Keep flames away from battery.
- Battery may generate hydrogen gas and may explode.
- Battery electrolyte is dilute sulfuric acid.
In case of mishandling, it could cause skin burning.
- When you deal with a battery, please be sure to wear protection implements, such as protection glasses and a glove.
- Dispose of battery, observing local regulations.



D004

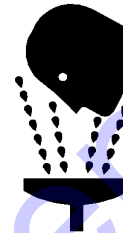

TR0093

WARNING

Cautions of hose attachment and removal

- Piping or the hose from this machine service valve should use what can be borne enough for the discharge pressure of this machine.
- Please connect piping or a hose to this machine service valve firmly before operation and during operation. If the connection part is loosening, there is a possibility of piping or a hose separating and getting seriously injured.
- Please remove after closing a service valve and extracting pressure remained, in case piping or a hose is removed. If pressure remained should remain, a near thing blows away or there is a possibility of a hose whipping, causing a phenomenon and getting seriously injured.
- In order to use it safely, please read the handling of the work tools often used.

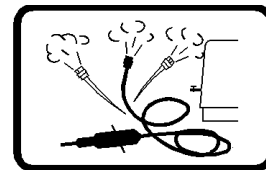

TR0088

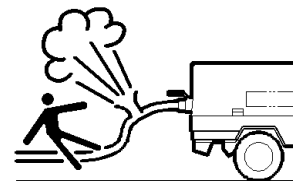

TR0303A

WARNING

Safety outfit

- When handling machine, do not wear;
 - loose clothes
 - clothes with unbuttoned sleeves
 - hanging tie or scarf
 - accessories such as dangling jewelrySuch outfit could be caught in the machine or dragged in the rotating portion of the machine, and this could cause a serious injury.



TR0084

1.Safety

WARNING

Maintain both physical and mental health

- Do not operate the machine when you are tired or drunk or under the influence of drugs. Otherwise, a hasty conclusion or careless handling may cause unexpected injury or accident. Manage your physical and mental health and be cautious in handling the machine.

CAUTION

Protection equipments

- Please wear protection implements, such as a helmet, protection glasses, earplugs, safety shoes, a glove, and a protection-against-dust mask, according to the contents of work for safety.



TR0085

CAUTION

Safety fittings

- Have first-aid boxes and fire-extinguishers near the unit ready for emergency situations such as injuries and a fire.
- It is advisable to have a list of phone numbers of doctors, ambulance and the fire department available in case of emergency.



TR0096

CAUTION

Safety around the machine

- Such things as unnecessary equipment and tools, cables, hoods, covers and pieces of wood which are a hindrance to the job, have to be cleaned and removed. This is because operators and/or personnel nearby may stumble on them and may be injured.
- Place safety enclosures at the entrance of and around working site to prevent children or outside people from entering the site.

1.Safety

1.2 Caution during Operation



WARNING

Do not replenish compressor oil during operation

- Do not, under any circumstance, open the oil filler cap of separator receiver tank while running or immediately after stopping operation.
It is very dangerous because the oil filler cap could be blown off and high temperature compressed air and oil could jet out from the filler port, and cause serious injury.

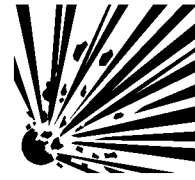

W010



WARNING

Draining during operation prohibited

- Do not, under any circumstance, open the portions below during operation:
- Separator receiver tank drain valve
- Coolant drain valve and plug
- Engine oil drain valve
- Oil cooler drain valve



PK0028



WARNING

Never direct the compressed air to people and belts

- Never blow compressed air directly at people.
Scattered impurities, dust, or foreign objects in the compressed air may cause skin and eyes to be seriously injured.
- Blowing compressed air on food is prohibited.

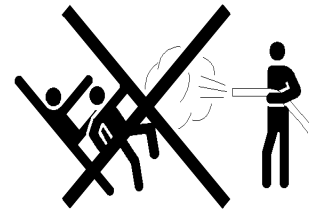

TR0092



WARNING

Hands off from rotating parts and belts

- Keep hands off from the rotating portion or belts while running.
It could cause serious injuries if hands should be caught in.

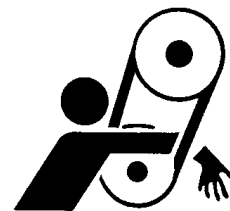

TR0304



CAUTION

Do not remove radiator cap during operation

- Do not, under any circumstance, open the radiator cap while running or immediately after stopping operation. Otherwise high temperature steam jets out and this could cause scalding.



H990432

1.Safety



CAUTION

Operation with compressed air supply port opened is prohibited

- Do not operate the machine with service valves and relief valve open unless air hoses and/or pipes are connected. High-pressurized air blows out and its air pressure could cause injury to the people nearby.
- When the machine has to be unavoidably temporarily operated with its port open, be sure to mount a silencer to reduce noise and wear protective materials such as earplugs to prevent damage to hearing.

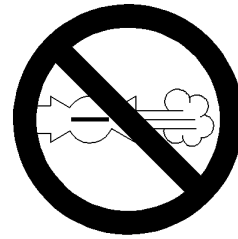

D003



CAUTION

Do not touch hot parts

- Never work nearby hot portions of the machine while it is running.
- Do not touch hot portions of the machine while inspecting the machine when running.
- Such parts as engine, exhaust manifold, exhaust pipe, muffler, radiator, oil cooler, compressor, piping, separator receiver tank, and discharging pipe are especially hot, so never touch those parts, because it could cause serious burns.
- Compressor oil, coolant water, and engine oil are also very hot and dangerous to touch. Avoid checking or refilling them while the unit is running.

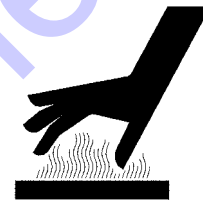

H990432



CAUTION

Fire prevention

- Do not, under any circumstance, bring lit cigarettes or matches near such oils as engine oil and compressor oil, etc. They are extremely flammable and dangerous, so be careful when handling.
- Refilling oils should be done in an outdoor well-ventilated place.
- Refuel after stopping the engine, and never leave the fuel nearby the machine. Do not spill. It may cause a fire. When it is spilt, wipe it up completely.
- Such parts as muffler and exhaust pipe can be extremely hot. Remove twigs, dried leaves, dried grass and waste paper, etc. from the exhaust outlet of the muffler.
- Keep a fire extinguisher available by the machine in case of a fire.



D004



H990433

1. Safety

1.3 Caution during Inspection and Maintenance

WARNING

Hang a "Now Checking and under Maintenance" tag

- Remove the starter key from the starter switch before starting inspection, and hang up a "Now Checking and under Maintenance" tag where it can be easily seen. The checker must keep the key during checking and maintenance.
- Remove the negative (-) side cable from the battery.
If the above procedure is neglected, and another person starts operating the machine during check or maintenance, it could cause serious injury.

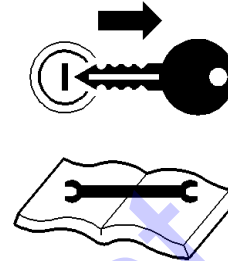

SY001

WARNING

Be careful of high-pressurized air blowout

- After stopping the engine, make sure that pressure gauge indicates 0MPa. Even when the gauge shows 0MPa, open a service valve and further do not fail to make sure that there is no residual pressure in the air piping. Then start such a job as repair and maintenance.
- Residual air under pressure will blow off and severely injure operator.

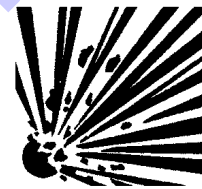

W010

WARNING

Refilling of compressor oil

- When you refill the separator receiver tank with compressor oil, stop the engine, and make sure that the pressure gauge indicates 0MPa and there is no residual pressure in it, and then gradually loosen the oil filler cap for refilling oil.
- Note residual pressure in the separator receiver tank could force both extremely hot compressed air and oil to jet out and you may be scalded or seriously injured.

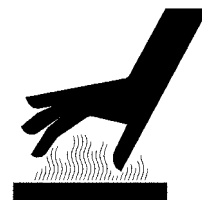

H990432

WARNING

Draining separator receiver tank

- After stopping the engine, confirm that the pressure gauge indicates 0MPa and there is no residual pressure in it, then open the drain valve gradually to drain the compressor oil.
- Note residual pressure in the separator receiver tank could force both extremely hot compressed air and oil to jet out and you may be scalded or seriously injured.

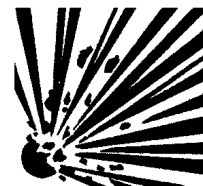

W010

1.Safety

WARNING

Adjusting tension of fan belt

- Be sure to stop the engine and remove the starter key whenever the tension of the fan belt is to be adjusted.
- Remove the negative (-) side cable from the battery.
- If the machine is running, it might catch the operator's hand into the fan belts, and this could cause a serious injury.

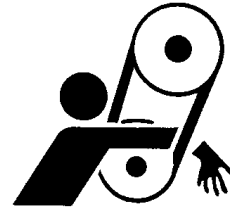

TR0304

WARNING

Hands off from cooling fan

- Be sure to stop the engine and remove the starter key whenever check or maintenance work is carried out near the cooling fan.
- If the cooling fan is rotating, it may catch the operator or part of his body into the fan, and it could cause a serious injury.

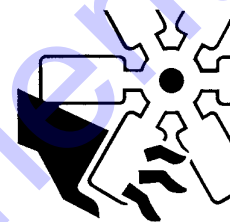

W009

WARNING

Cleaning by air-blow

- When cleaning dust accumulated in such devices as the air-filter, by blowing compressed air, wear safety glasses, etc. to protect your eyes.



M003

CAUTION

Lighting apparatus

- It is recommended to use a lamp with safety guard fitted where the site is dark.
Operating the machine gropingly or by relying on one's intuition could cause unexpected accidents.
- Any lamps without safety guard are not recommended since they can be broken and they could ignite flammables such as fuel, etc.

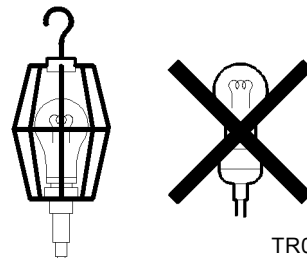

TR0206

1.Safety

CAUTION

Opening coolant water drain valve cap

- Be sure to stop the engine, and let the coolant water sufficiently cool down before draining it.
- If the drain valve is opened before the coolant water is cooled enough, hot water could jet out, and it could cause scalding.



H990432

CAUTION

Refilling or draining of engine oil

- After stopping the engine, wait for 10 to 20 minutes until the engine oil cools off. Then check the level of the engine oil, or refill or drain the oil.
- Engine oil is very hot and highly pressurized during or just after the operation. Hot oil could blow out of the tank and can cause scalding.



H990432

CAUTION

Fear of fire

- Be sure to perform the periodical check of compressor oil and oil separator.
- Neglecting checks could cause overheat of the oil, resulting in a fire.



H990433

CAUTION

Disposal of waste liquid, etc.

- Waste liquid from the machine contains harmful material. Do not discharge it onto the ground or into the river, lake or sea. Such material will contaminate the environment.
- Be sure to use a container to hold the waste liquid from the machine.
- Be sure to follow the designated regulations when disposing of oil, fuel, coolant (antifreeze), filter, battery or other harmful materials.

1. Safety

1.4 Safety Warning Labels

Folling labels are attached to the machine.

Keep them clean all the time. If they are damaged or peeled off, immediately place an order with your nearest dealer for replacement, with the number indicated on the lower right corner of the label. Adhere a new one to the original place.

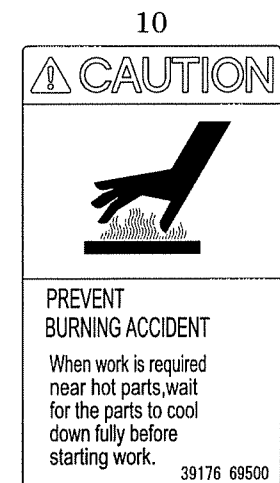
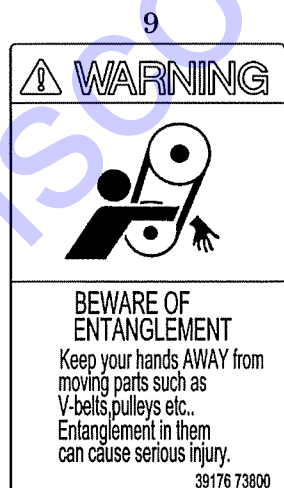
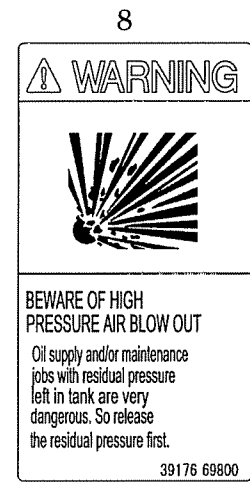
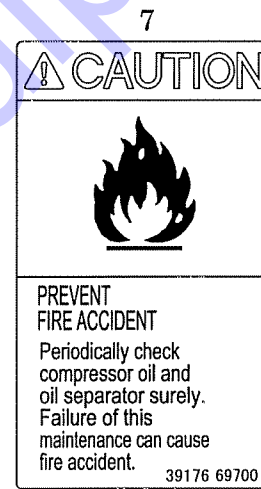
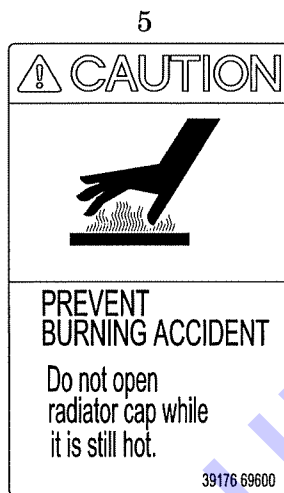
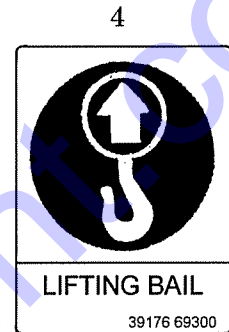
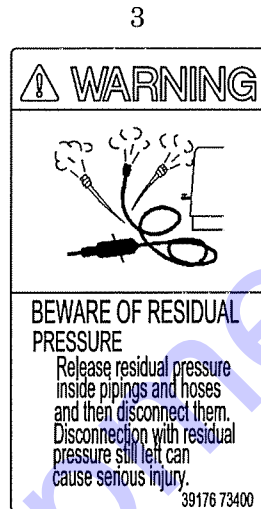
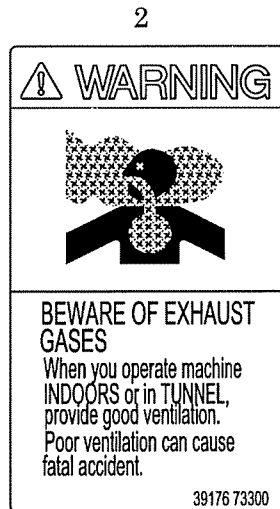
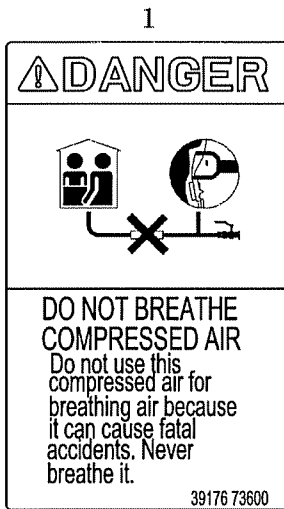

1.Safety

The pasting position of safe warning label is as follows.

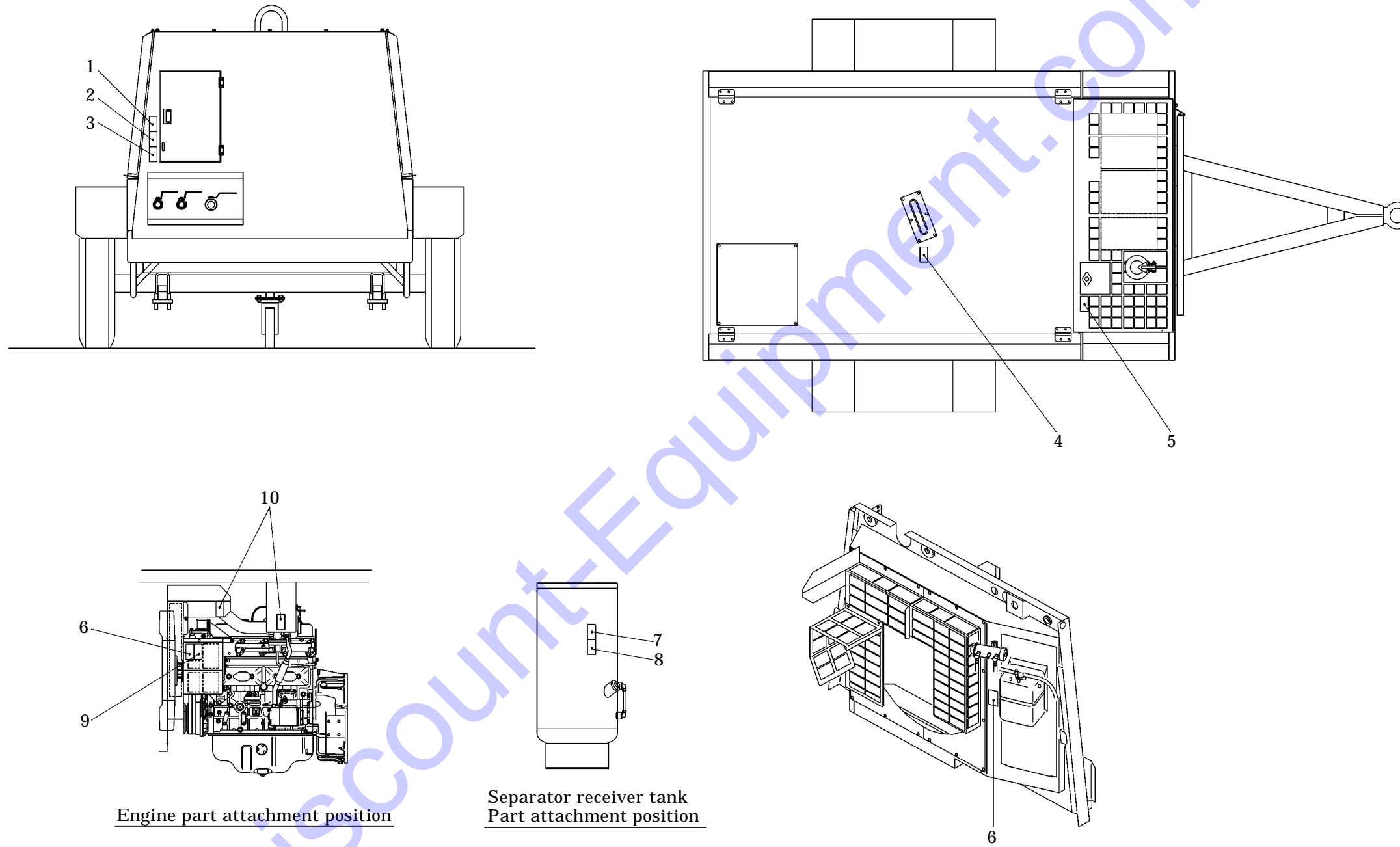

Engine part attachment position

Separator receiver tank
Part attachment position

A040036

2. Part Names

2.1 Unit Appearance and Part Names

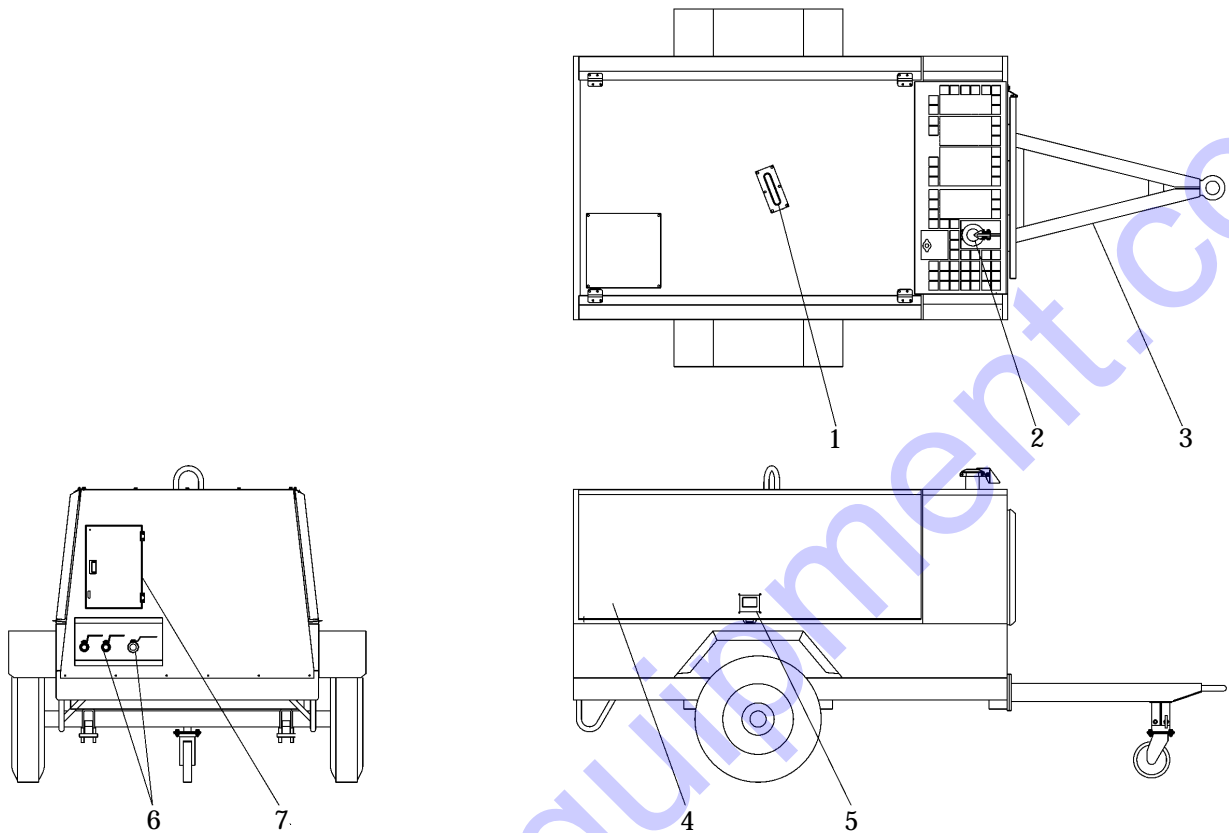

A040037

1. Lifting bail
2. Exhaust outlet
3. Drawbar
4. Door

5. Handle
6. Service valve
7. Instrument panel

2. Part Names

2.2 Internal Components and Part Names

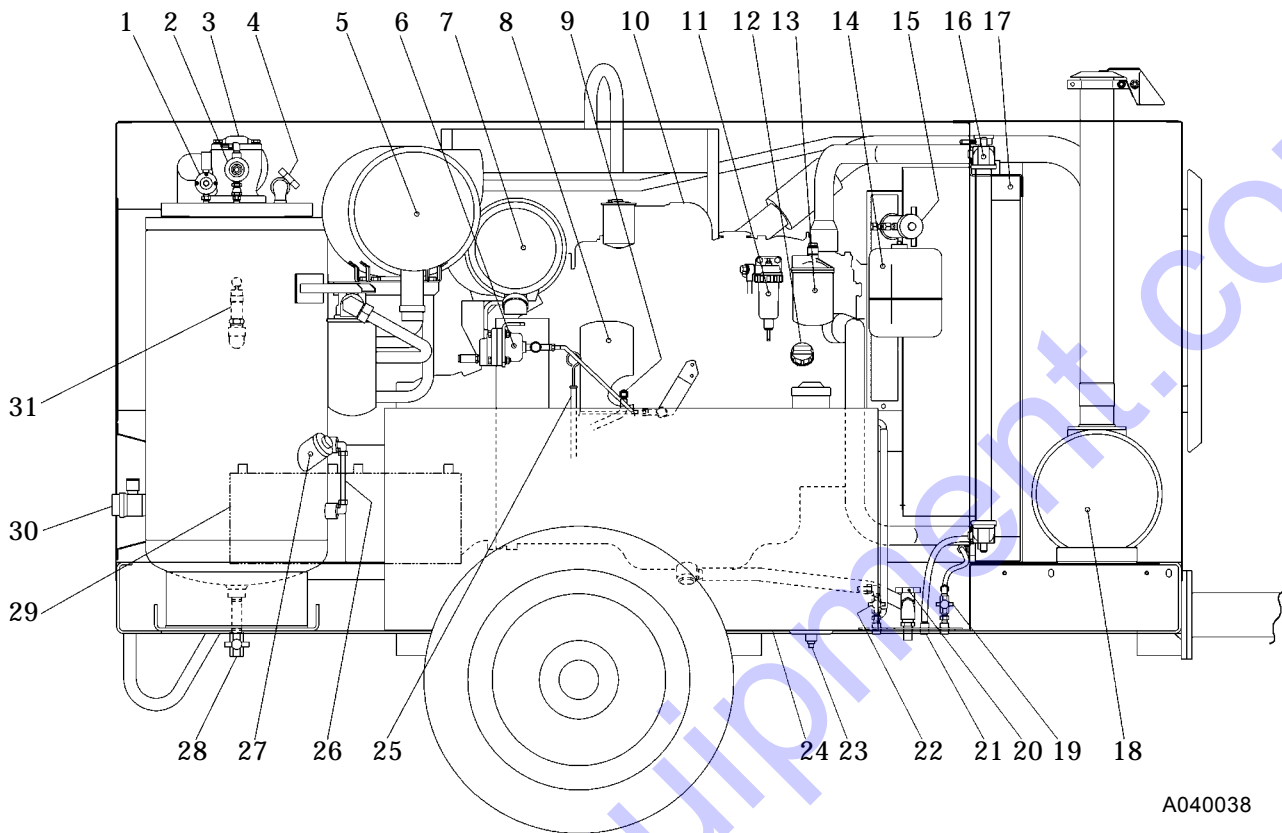

- | | |
|--|-----------------------------------|
| 1. Auto-relief valve | 17. Oil cooler |
| 2. Pressure regulator | 18. Exhaust muffler |
| 3. Pressure control valve | 19. Oil cooler drain valve |
| 4. Relief valve | 20. Engine oil drain valve |
| 5. Air filter element (compressor) | 21. Coolant drain plug (radiator) |
| 6. Speed regulator | 22. Engine oil filter drain valve |
| 7. Air filter element (engine) | 23. Fuel tank drain plug |
| 8. Engine oil filter | 24. Fuel tank |
| 9. Coolant drain plug (engine) | 25. Engine oil level gauge |
| 10. Engine | 26. Compressor oil level gauge |
| 11. Water sedimenter | 27. Compressor oil filler port |
| 12. Engine oil filler port | 28. Compressor oil drain valve |
| 13. Fuel filter | 29. Battery |
| 14. Reserve tank | 30. Service valve |
| 15. Fuel air bleeding electromagnetic pump | 31. Safety valve |
| 16. Radiator | |

3. Installation

3.1 Transportation



WARNING

Transportation

- When loading and unloading unit, be sure to use the lifting bail provided on the center of the unit top.
- Never get under the unit which is lifted up, because it is very dangerous.
- When unit is transferred or moved from working site, be sure to place it on truck bed, and fasten it by ropes at the front eye and rear stand. Also be sure to put a set of chocks to fix its wheels firmly on the truck bed.
- Never lift unit which is still in operation, or it could cause critical damage to each component or lead to serious accident.
- When lifting unit up, make sure that all the fixing bolts on the bonnet are surely tightened because it is feared that the unit may fall.
- If towing unit : Make sure machine is towed level.
- Check tire pressure and tire condition before towing.
- Attach safety chains and use correct tow hitch.
- Check operation of lights and brakes before towing.
- Check wheel lug nuts for proper torque.

Lifting up

Before lifting the unit up, make sure to check the lifting bail “ 2 ” for any crack and loosened bolts.

Connect the hook “ 1 ” of the crane or shackle with lifting bail “ 2 ” eye fitted at the top center of the unit, and make sure that there is no person standing around the unit. Then perform hoisting operation.

Use an auxiliary rope “ 3 ” and communicate with the other personnel using signs and signals while lifting operation, so that no swinging motion or twisting happens to the lifted unit.

Select a truck or a crane with capacity sufficient for weight and size of the unit by referring to the values shown in Chapter 8 “Specifications” of the manual.

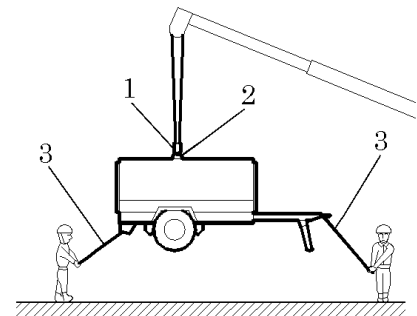

A000053

Lowering the unit from the truck bed pulling down

- Lower the unit down onto a level place which can sustain the weight of the unit.
- After placing the unit down, put chocks to lock the wheels before unfastening the crane's shackles.

3. Installation

3.2 Towing the Unit

WARNING

- Keep traction speed lower than 20 km/h.
(High speed model is lower than 80 km/h)
- Select a tractor with capacity sufficient for weight and size of this unit.
- It is 60 psi (4.2 bar) what is standard air pressure of tire.
- Replace the defaced or damaged tire
- Don't change the size and kind of this machine's tire.
- Check the tractor and draw-bar of this unit, and check whether they are deformed or damaged.
- When setting or off setting of the tractor and this machine, do not put hands and fingers into the connecting portion.
- Confirm that the tractor and the unit are firmly connected.
- Confirm that there are nobody and not any obstacles at the back and front.
- Do not tow the unit without unfastening tool, equipment and tools.
- Do not enter or walk through between the tractor and this machine.
- Be sure to follow the safety warning and cautions.
Unsafe operation could cause serious injury or death to the personnel.

- After making sure that there is not any behind the tractor, move the unit back.
So that it can be connected by coupler.
- Connect completely the joint at the draw bar of the unit and tractor, while towing could not happen loosen or disconnecting.
- Take out chocks from the tires of the unit.
- When towing, do not drive roughly and carefully drive, avoiding dangerous rough areas.

CAUTION

- Before towing the unit, check the following points and be sure to repair failures, if any:
 - Air-pressure in the tires.
 - Loose wheel bolts or nuts.
 - Abnormal wear or damage to the tires.
 - Damage of draw-bar.
- Be sure to use a vehicle with tractive ability heavier than the weight of compressor.
- Do not tow the unit without unfastening tool, equipment, and hoses.
Keep hands and fingers clear during hook-up or unhooking draw-bar.
- Be sure to follow the above instructions. Otherwise, such improper operation will cause serious injury or even death to the personnel.

3. Installation

3.3 Location and Installation

WARNING

- Exhaust gas from the engine is poisonous, and could cause death when inhaled.
Avoid using the machine in an insufficiently ventilated building or tunnel.
- Do not position the exhaust gas outlet in direction of a person or a house.

Ventilation

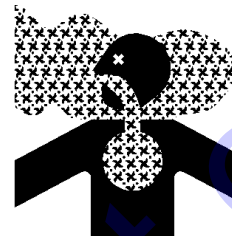

PC002

WARNING

- The machine has to be parked horizontally on a level place.
- In case the machine has to be parked on a slope, place it across grade so that the machine does not tend to roll downhill.
- Grade on a slope shall be within 15 degrees
- Be sure to put one set of chocks " 1 " to the wheels.

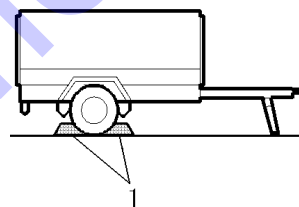

A000054

- The machine should be operated in following conditions:
- Ambient temperature 5 °F to 104°F (- 15°C to + 40°C)
- Humidity Less than 90%
- Altitude Lower than 4,921 ft (1,500 m) above sea level
- Install the machine in a place with good ventilation, lower temperature and with surroundings as dry as possible.
- If more than two machines are placed parallel in operation, keep enough distance so that exhaust air from one machine does not effect the other one.
- Also, a machine has to be installed in the environment where fresh air is always available.
- Keep enough space around the unit for inspection and maintenance access.

4. Operation

4.1 Instrument Panel

1. Fuel level gauge
2. Coolant temperature gauge
3. Discharge air temperature gauge
4. Differential pressure gauge of oil separator
5. Tachometer (with hourmeter)
6. Discharge air pressure gauge
7. Starting unloader valve
8. Starter switch
9. Emergency stop button

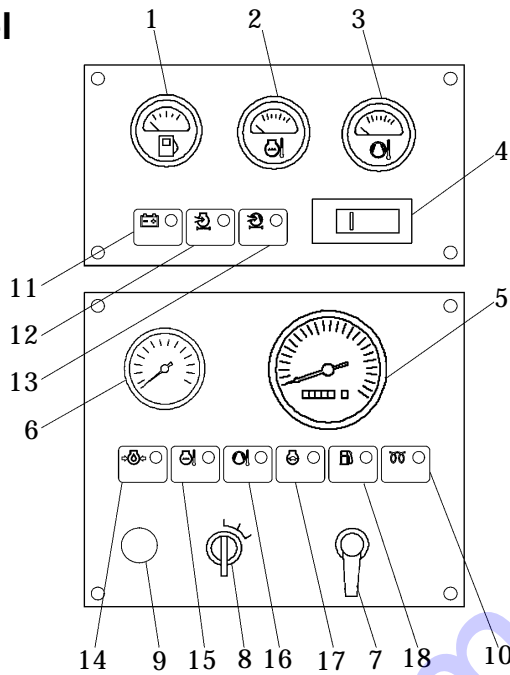

- < Indicator lamp >
10. Preheating
- < Warning lamp >
11. Charging
 12. Engine air filter
 13. Compressor air filter
- < Emergency stop lamp >
14. Engine oil pressure
 15. Coolant temperature
 16. Discharge air temperature
 17. Engine speed down
 18. Fuel residual level

Indicator lamp

NO.	Item	Trouble	Measures	Monitor
10	Preheating	Press starter switch "ON" and the lamp goes on and after preheating is finished, the lamp will be off.	—	

Warning lamp

When the lamp goes on, take appropriate measures to recover the situation swiftly.

NO.	Item	Trouble	Measures	Monitor
11	Charging	Lamp goes on when alternator is not charging.	Check wiring. Check alternator.	
12	Engine air filter	Lamp goes on when filter is clogged.	Check/Clean air filter	
13	Compressor air filter	Lamp goes on when filter is clogged.	Check/Clean air filter	

Emergency stop lamp

The compressor stops when the lamp goes on.

Be sure to follow the measures shown below before starting the unit again.

NO.	Item	Trouble	Measures	Monitor
14	Engine oil pressure	Lamp goes on when engine oil pressure drops. The function pressure is below 22psi(1.5bar).	See "Troubleshooting"	
15	Coolant temperature	Lamp goes on when coolant temperature reaches 221°F (105).	See "Troubleshooting"	
16	Discharge air temperature	Lamp goes on when the air temperature at the outlet of the air-end reaches the set temperature of 248°F (120).	See "Troubleshooting"	
17	Engine speed down	Lamp goes on when Engine run on with lower than 1000min ⁻¹ .	See "Troubleshooting"	
18	Fuel residual level	When fuel level of fuel tank becomes lower, the lamp goes on.	Add fuel oil	

4. Operation

4.2 Door

4.2.1 Open/Close the Door

WARNING

- Keep the door closed and locked while running the unit.
- When the door has to be opened, be careful not to touch portions that are rotating or very hot. Careless touch may cause serious injury.



PK0028

- Pull the handle forward to open the door.
- Be sure to close the door tightly so that its latch is firmly caught.

4.3 Check before Starting Unit

CAUTION

Check before starting the unit

- Be sure to check the unit before operation. When any abnormality is found, be sure to repair it before restarting the unit.
- Be sure to make daily checks before operation. If the unit is operated without prior check and without noticing its abnormality, such operation could cause seizure of components or may even cause fire.

4.3.1 Check Engine Oil Level

- Unit should be on level before checking oil level.
- When you check oil level after you have once started operation, wait 10 to 20 minutes after stopping engine, before checking the oil level.

(Procedure)

Pull out the engine oil dipstick, and wipe it with a clean cloth.

Then, re-insert the dipstick fully and pull it out again. If the dipstick shows the oil level between MIN and MAX, it is normal.

When the oil level is below its MIN, add engine oil.

(See 5.6.1)

- While checking oil level, check also for contamination. If the oil is found dirty, contaminated or should it be changed according to the periodic inspection list, change the oil.

(See 5.6.1)

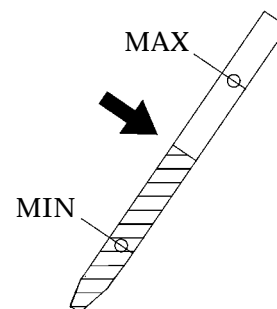

A000166

4. Operation

4.3.2 Check Coolant Level

CAUTION

Taking off the Header tank radiator cap

- Be sure to stop the machine and allow time to cool. Then loosen the radiator cap one notch. After the coolant water is sufficiently cooled and the inner pressure is released, take the cap off. If this procedure is neglected, the inner pressure can blow off the cap. Steam jetting out of the radiator could result in causing scalding. Follow this procedure under all circumstances.



W005

- Check the coolant level in the reserve tank. If it is lower than the limit, open the cap and replenish the coolant. (Level must be kept above LOW mark.)
- If little coolant is left in the reserve tank, replenish the radiator with cooling water. (See 5.6.12)

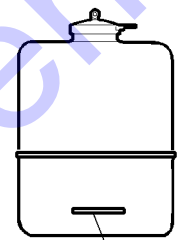

LOW

A030173

IMPORTANT

- Do not continue operation at low coolant level. Air bubble is mixed into radiator, and it causes damage to the radiator.

4. Operation

4.3.3 Check Compressor Oil Level



WARNING

Refilling of compressor oil

- When you refill the separator receiver tank with compressor oil, stop the engine, and make sure that the pressure gauge indicates 0MPa and there is no residual pressure in it, and then gradually loosen the oil filler cap for refilling oil.
- Note residual pressure in the receiver tank could force both extremely hot compressed air and oil to jet out and you may be scalded or seriously injured.



- Place the machine on level ground when checking the oil level.
- Check the oil level of the compressor. Correct oil level is between upper and lower limit of the gauge, when the unit stops. If the gauge shows lower than the middle level, replenish oil. (See 5.6.5)

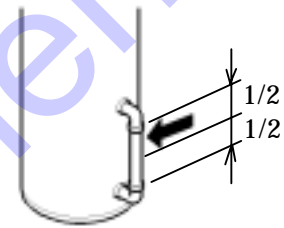

H000037

4.3.4 Drain Separator Receiver Tank



WARNING

Draining of Separator receiver tank

- After stopping the engine, confirm that the pressure gauge indicates 0MPa and there is no residual pressure in it, then open the drain valve gradually to drain the compressor oil.
- Note residual pressure in the receiver tank could force both extremely hot compressed air and oil to jet out and you may be scalded or seriously injured.



H990432

- Gradually opening the drain valve " 2 " fitted under the separator receiver tank " 1 " as shown in the fig, drain the condensate.
- Be careful not to fully open the valve. Otherwise, much oil may be lost.
- After draining the oil completely, close the drain valve " 2 " firmly.
- Drain the condensate in container " 3 ", dispose of the waste oil according to the designated regulations.

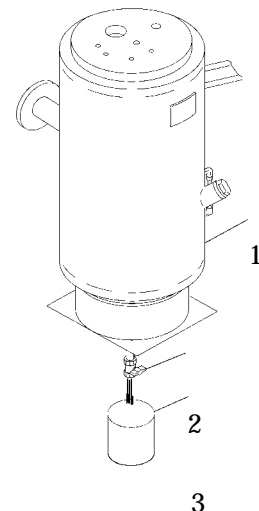

4. Operation

4.3.5 Drain Water Sedimenter

Check if the red float " 1 " in the water sedimenter rises up to the water drain level " 2 " , then drain water if it is near the drain level.

(Draining procedure)

Loosen the drain plug " 3 " and drain out condensed water inside.

After draining condensed water, close the drain plug " 3 " without fail.

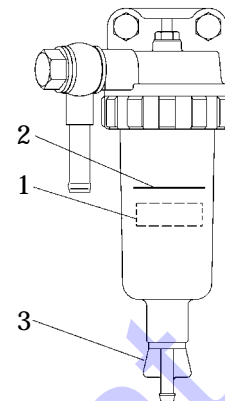

A020404

4.3.6 Check Fuel level

CAUTION

Fire prevention

- Do not, under any circumstance, smoke cigarettes or light matches during fueling.
- Fuel is extremely flammable and dangerous. It therefore, could catch fire should it flame or other sources of ignition be brought near fuel.
- Refuel only after stopping the engine, and never leave an open fuel can near the machine. Do not spill. It could cause a fire. When it is spilt, wipe it up completely.
- Refilling fuel tank should be done in an outdoor well-ventilated place.



D004

IMPORTANT

Choose appropriate fuel

- Be sure to use diesel fuel oil for diesel engine use.
(Using other oil will cause low power or damage to the engine.)
- Check fuel level gauge before operation. Replenish enough fuel to prevent fuel shortage during operation, if the level is low.
When refueling, fill a fuel tank up to the base of fuel filler port. Never overfill fuel because it may cause fuel leakage.
- Be sure to fasten the fuel tank cap firmly after replenishment. If fuel is spilt, wipe it up completely.

4. Operation

4.3.7 Check V-Belt Tension

IMPORTANT

- Too tight belt tension could damage shaft and shorten bearing life. Too loose belt tension may result in damaging belt earlier and machine components due to overheat.

Follow the procedure below to adjust tension of fan belt and V-belt for alternator.

(Procedure)

Adjust the tension by gradually loosening the fastening bolt of the alternator.

Visually check if there are any cracks or tears in the belt.

Loosen the fastening bolt of the alternator until the play of the belt reaches 0.3 to 0.5in [22 lbf (98N)] when pushed by fingers, and adjust it.

Be careful not to leave any grease or LLC on a belt while changing it. If any such material is left, wipe it off completely.

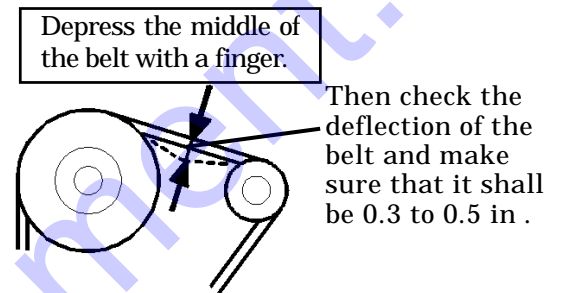

A010181

4.3.8 Check Wiring of Each Part

Check each wiring for any loose connection, damage to insulating sheathed portion, disconnection, and short-circuit.

4.3.9 Check Piping of Each Part

Check each piping for any loose connection and also check each hose and pipe for any tear and leaks.

4. Operation

4.4 Unit Operation



Operation with compressed air supply port opened is prohibited

- Do not operate the machine with service valves open unless air hoses and/or pipes are connected. High-pressurized air blows out and its air pressure could cause injury to the people nearby.
- When the machine has to be unavoidably temporarily operated with its port open, be sure to mount a silencer to reduce noise and wear protective materials such as earplugs to prevent damage to hearing.

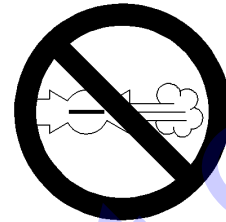

D003

Quick Glow System

- Turn the starter switch to the "RUN" position, and the preheating will be completed in several seconds and the preheating lamp will go out. Then, turn the starter switch to the "Start" position to start up the engine.
- When the engine is already warm, the preheating operation is automatically omitted. Even though the preheating lamp lights up momentarily, ignore the lamp status, and start up the engine.

4. Operation

4.4.1 Procedure to Start the Unit

IMPORTANT

——— *Be sure to warm-up* ———

- Be sure to let unit warm-up after starting for smooth operation of the engine and the compressor. Do not operate the engine at full load immediately after it starts up. This will shorten the equipment life.
- During the warm-up operation, examine the different parts of the equipment for any looseness, leakage of water, oil, fuel, and other irregularities.
- Also, make sure that warning lamps are off.

(Procedure)

- ① Close fully service valves.
 - ② Set the starting unloader valve "1" to "START" position.
 - ③ Turn to clockwise enough the starter switch with pushing the emergency stop button "4". and then do cranking engine about 5 seconds.
 - ④ Turn the starter switch "2" to "RUN" position, and the preheating lamp "3" goes on.
 - ⑤ As soon as the preheating lamp "3" has gone out, turn the starter switch "2" fully clockwise to start up the engine.
 - ⑥ Open the engine has started up, leave it running to warm-up for 5 minutes. The discharge air pressure in this condition ranges from 57 to 100psi (3.9 to 6.9 bar) .
 - ⑦ After warm-up of the unit, put the starting unloader valve "1" back to its "RUN" position, and open the service valve. The unit is now ready to operate.
- Be sure to turn the starting unloader valve "1" to "RUN" position prior to work. The discharge pressure does not increase as long as the starting unloader valve "1" stays at "START" position.

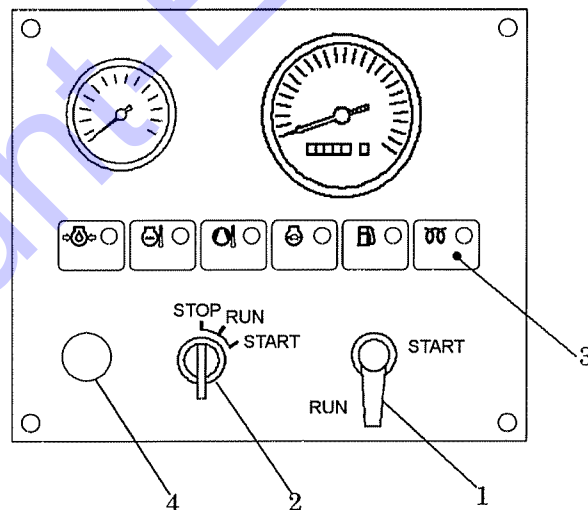

A040042

4. Operation

4.4.2 Operating Procedures when Engine Fails to Start up on First Attempt

- When the engine fails to start up even after performing the start up procedures to , do not keep the starter running, but set the starter switch back to "STOP" and wait about 30 seconds. Then, repeat the startup procedure once again.
- If the repeated procedure does not allow the engine to run, the following causes are suspected. Therefore, check the following:
 - No fuel
 - Clogging of fuel filter
 - Clogging of filter inside the fuel air bleeding electromagnetic pump
 - Discharge of battery (Low cranking speed)

4.4.3 Fuel Line Air Bleeding Device

When draining condensate in water sedimenter and replacing fuel filter, the electromagnetic pump provided as an accessory performs air bleeding operation automatically.

(Procedure)

Check and make sure that fuel is fully provided.

Turning the key of starter switch to "RUN" position, the electromagnetic pump starts to bleed air in the fuel piping system automatically.

Air bleeding will be completed about 20 to 30 seconds.

Start the machine following the starting procedures mentioned in 4.4.1. If starting fails one time, repeat the abovementioned procedures.

4.4.4 How to Start the Unit at Low Temperature

When it is difficult to start engine in cold weather, take the following measures.

(Procedure)

Close all the service valves and set the starting unloader valve to "START" position.

Fully open the relief valve "1" in the upper part of a separator receiver tank.

With emergency stop button pressed in, turn the starter switch to "START" position and perform cranking about 5 seconds two times.

Perform usual starting operation. When the engine starts, gradually close a relief valve "1", watching engine revolution rise. In the state after the valve is fully closed, perform warming-up operation.

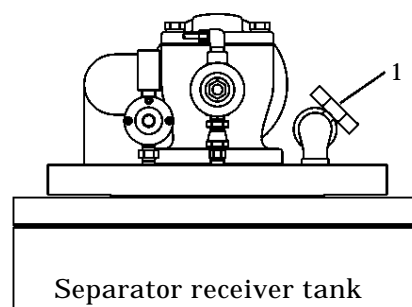

Separator receiver tank

A040042

IMPORTANT

— **Operation under Cold Weather Conditions below 23°F (-5°C)** —

- Use SAE10W-30 (CD class) for the engine oil.
- Use LLC (antifreeze).
- Use correct amount to provide freeze protection, according to the ambient temperature. (See 5.6.13)
- Battery should always be kept fully charged.











4. Operation

4.4.5 Gauge Indication while Operating







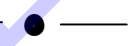

IMPORTANT

- Minimum discharge air pressure is 58psi (4.0 bar) during operation
- Continuing equipment operation at a lower pressure than the above pressure may cause overheating, since it affects the separation of lubricating oil inside the oil separator and reduces the oil flow to the compressor air-end, resulting in temperature rise.
- Make sure that RPM is higher than $1,000\text{min}^{-1}$ at no load (or low load) operation. Long continuous operation at the lower speed than $1,000\text{min}^{-1}$ could cause damage to each part by vibration. When the speed becomes lower than $1,000\text{min}^{-1}$, stop the machine soon.

- Be sure to check at times to see if gauges or each component of the unit are properly working, or if there is any air-leak, oil-leak, water-leak or fuel-leak etc.
- During normal operation, each indication of instruments is shown in the table below. Refer to the table for daily checks.
- The above table gives standard values. They may vary slightly depending on the operating conditions and other factors.

Protection device	Emergency Lamp				
	Engine oil pressure	Coolant temperature	Discharge air temperature	Engine speed down	Fuel residual level
Monitor					
Starting	Starter switch set to "RUN" position			1	
	 ON	 OFF	 OFF	 OFF	 OFF
In Operation	 OFF				

Note: 1 When engine rises, a lamp goes on temporarily.

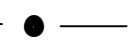
Protection device	Warning Lamp			Indicator Lamp
	Charging	Engine air filter	Compressor air filter	Preheating
Monitor				
Starting	Starter switch set to "RUN" position			2
	 ON	 OFF	 OFF	 ON
In Operation	 OFF			

Note: 2 Lamp goes off after preheating completed.

		Discharge air pressure
In Operation	At Unload	100 to 135psi (6.9 to 9.3 bar)
	At Full Load	58 to 100psi (4.0 to 6.9 bar)

4. Operation

4.4.6 Check Clogging in Oil Separator

When the differential pressure gauge of oil separator shows red range, replace the oil separator. (See 5.6.15)

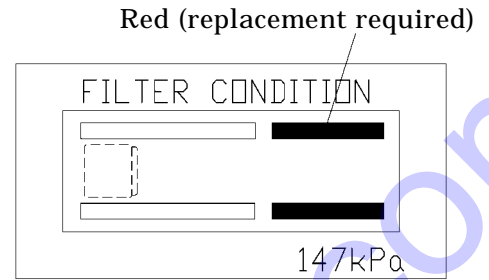

H000477

4.5 Stopping Procedures

Close the service valve completely and operate the machine about 5 minutes, until it cools down.

Turn the starter switch to "STOP" position to stop the engine.

Remove the key from the compressor every time when you stop the engine. Keep the key and be careful not to lose it.

- Unless all the service valves are fully closed upon stopping operation, the compressed air will be sent in reverse direction in the hoses (pipes) connected to air tools and relieved to atmosphere continuously through the auto-relief valve. Further, when re-starting operation next time, compressor oil will be jetted out through service valves.

5. Periodic Inspection/Maintenance

5.1 Important Items at Periodic Inspection and Maintenance or after Maintenance

The manual shows proper interval for periodic inspection and maintenance under normally operating conditions. Inspection and maintenance should be performed more often under extremely harsh conditions.

WARNING

Hang a "Now Checking and under Maintenance" tag

- Remove the starter key from the starter switch before starting inspection, and hang up a "Now Checking and under Maintenance" tag where it can be easily seen. The checker must keep the key during checking and maintenance.
- Remove the negative (-) side cable from the battery.
If the above procedure is neglected, and another person starts operating the machine during check or maintenance, it could cause serious injury.
- Use tools appropriate for the inspection and maintenance. Any makeshift or improper tools could cause unexpectedly injury by their slippage.

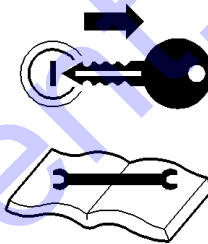

SY001

CAUTION

For protecting oil separator from fire accident

- Be sure to perform oil change basically according to the specified interval. But if such oil is found much more contaminated before the interval, change the oil even before the specified period comes. In doing so, replace the oil completely and use our recommended oil.
- Be sure to perform following periodic inspection and maintenance:
 1. Check and change compressor oil
 2. Change oil separator
- Never mix the oil of different brands, or the mixed oil may deteriorate the oil quality.

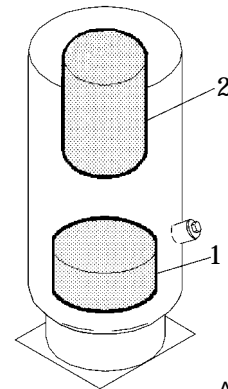

A030180

CAUTION

- Waste from machines contains harmful material. Do not dispose of such harmful fluids to the ground, rivers, lakes or ponds, and sea. It contaminates the environment.
- When draining waste fluid from machines, use leakproof containers to hold such fluids from machine.
- Be sure to follow the designated regulations when disposing of oil, fuel, coolant, filters, battery and other harmful things.

5. Periodic Inspection/Maintenance

IMPORTANT

Precautions for check and maintenance

- Be sure to use recommended fuel, oil, grease, and antifreeze.
- Do not disassemble or adjust engine, compressor or part(s) for which inspection or maintenance is not referred to in this manual.
- Use genuine parts for replacement.
- Any breakdown, caused by using unapproved parts or by wrong handling, will be out of the scope of "WARRANTY".
- Keep the electrical components away from water or steam.

5.2 Daily Inspection and Operation Log

- Be sure to carry out daily inspection every morning before operation. See Chapter 2 "Operation" of the manual for the details of inspection.
- Pay attention to and carefully observe the following points during daily operation or inspection and maintenance work. If any trouble or abnormality is found, immediately investigate its cause and make repairs. If the cause is unknown or not traceable, or if the trouble involves a part or component not described in the manual, ask your nearest dealer for information.

- (a) Controls and instruments function properly.
- (b) Quantity and any leak of water, fuel, and oil or any contamination should be checked.
- (c) Appearance, abnormal noise or excessive heat should be checked.
- (d) Loose bolt or nut should be checked.
- (e) Any damage, wear or shortage of machine components and parts should be checked.
- (f) Performance of each part or component should be proper.

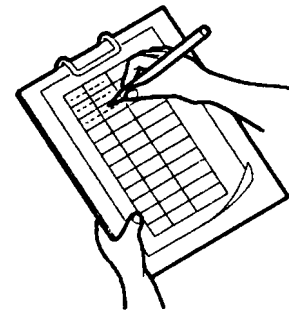

TR0049

- Keep the operation log to record constant inspection of each component, so that trouble of the unit can be easily discovered and preventive measures can be taken.
It is very useful to record information such as discharge pressure, oil level, as well as running hour, maintenance items and replenishment of lubricant on a daily maintenance log.

5.3 Inspection on Separator Receiver Tank

IMPORTANT

Periodic inspection of separator receiver tank

- Be sure to carry out the following cleaning and inspection of the separator receiver tank at least once every year.
(Place to check)
 - (1) Any damage found on the tank.
 - (2) Any excessive wear found to fastening bolts on the cover.
 - (3) Any damage found to pipes and valves etc.

5. Periodic Inspection/Maintenance

5.4 Periodic Inspection List

Such items marked shall be carried out by customers.

For the following items or clauses marked , contact us directly or our distributors because they require expert technical knowledge on them.

The following table shows the inspection and maintenance intervals under normal operation conditions. In case the unit is operated under harsh environmental conditions and operation conditions, the intervals should be shortened.

Refer to engine operation manual for inspection and maintenance of an engine.

(Unit:Hour)

	Maintenance	Daily	250	300	500	1,000	2,000	3,000	12,000	Page	
Compressor	Check compressor oil level.									4-4	
	Drain separator receiver tank.									4-4	
	Check looseness in pipe connecting part, and wear and tear of pipe.									4-6	
	Check oil, water, fuel and air leak.									4-10	
	Check performance of gauge and indication lamps.									4-10	
	Change compressor oil.			First time							5-7
	Change compressor oil filter.			First time							5-8
	Clean strainer in the scavenging orifice.										5-8
	Clean and change air filter element.										5-8
	Clean outside of the oil cooler.										5-9
	Supply grease to trailer spring pin										5-11
	Change speed regulator diaphragm.										
	Change unloader regulator o-ring.										
	Change oil separator.										5-11
	Change nylon tubes.										
	Change pressure regulator.										
	Check rubber hoses.										
	Check diaphragm of auto-relief valve.										
	Change pressure control valve of o-ring.										
	Change rubber coupling.										
Change oil seal and bearing											

5. Periodic Inspection/Maintenance

(Unit:Hour)

	Maintenance	Daily	50	250	500	1,000	2,000	3,000	6,000	Page
Engine	Drain water sedimenter									4-5
	Check fuel level									4-5
	Check engine oil level.									4-2
	Check coolant level.									4-3
	Check looseness in pipe connectors, terminals and tear in wiring.									4-6
	Check V-belt tension.									4-6
	Drain fuel tank									5-9
	Change engine oil.		First time							5-5
	Change engine oil filter.		First time							5-6
	Check battery electrolyte.									5-6
	Clean and change air-filter element.									5-8
	Change filter inside the fuel air bleeding electromagnetic pump.									5-9
	Change fuel filter.									5-9
	Clean the strainer provided inside the engine feed pump.									5-12
	Change coolant.									5-10
	Clean outside of radiator.									5-9
	Check rubber hose.									5-12
	Clean inside of radiator.									
	Clean inside of fuel tank.									
Change radiator hoses.										
Change wiring harness.										

5.5 Periodic Replacement of Parts

Part Name	Part Number	Quantity
Engine oil filter	ISUZU 1132402321	1
Compressor oil filter	37438 05601	1
Air filter element (compressor)	32143 12400 (inner element.)	1
	32143 12500 (outer element.)	1
Air filter element (engine)	32143 12600 (inner element.)	1
	32143 12700 (outer element.)	1
Fuel filter	ISUZU 1132400791	1
Oil separator ass'y " 1 "	34220 14900	1
Gasket " 2 "	34235 04400	1
Gasket " 3 "	34235 04300	1
Electromagnetic pump filter	ISUZU 8944370220	1
Fuel feed pump gasket	ISUZU 9-0957-2014-0	2

5. Periodic Inspection/Maintenance

5.6 Maintenance

5.6.1 Change Engine Oil

- At 50 hours for the first change and at every 500 hours thereafter



Caution in filling or discharging engine oil

- After stopping the engine, wait for 10 to 20 minutes until the engine oil cools off. Then check the level of the engine oil, or refill or drain the oil.
- Engine oil is very hot and highly pressurized during or just after the operation. Hot oil could blow out of the tank and can cause scalding.

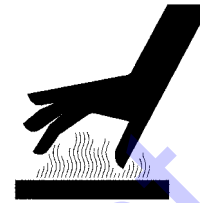

H990432

IMPORTANT

— How to choose engine oil —

- Viscosity of engine oil greatly affects startability, performance, oil consumption of the engine, as well as wear of the moving parts.
- Choose appropriate oil based upon the table below according to the outside air temperature.

Relation between viscosity (SAE) and temperature

SAE Viscosity number	Temperature
10W	- 22°F to 50°F (- 30 to 10)
30	14°F to 104°F (- 10 to 40)
40	32°F to 122°F (0 to 50)
15W/40	- 4° F to 104°F (- 20 to 40)

- Be sure to use CD class engine oil or superior class. (Using engine oil with poor quality may shorten the life of the engine).

(Procedure)

Loosen the drain valve " 1 " located inside of the frame to drain out the used oil.

When the oil is completely drained, close the drain valve " 1 " firmly and refill new engine oil through the engine oil filler " 2 " .

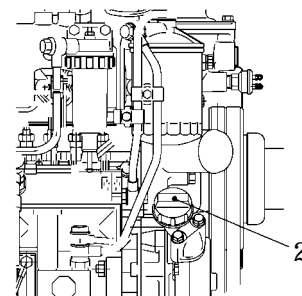
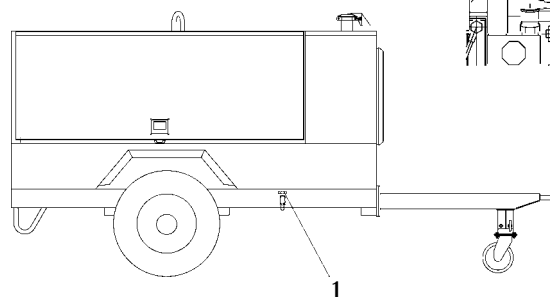

A040044

5. Periodic Inspection/Maintenance

5.6.2 Change Engine Oil Filter

- At 50 hours for the first change and at every 500 hours thereafter

(Procedure)

- ① Remove the cartridge "1", using a filter wrench.
- ② Screw in the new cartridge "2" with the packing coated slightly with oil. (For replacement parts, refer to 5.5.)
- ③ After the packing touches the sealing face, further tighten it by turning it 3/4~1 time with the filter wrench.
- ④ After installing the oil filter, check it for any leak during operation.

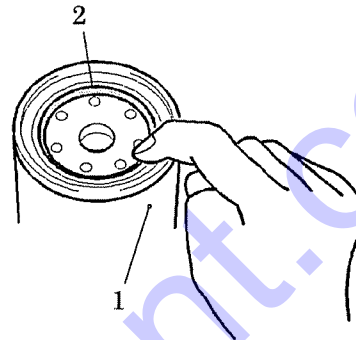

H000049

5.6.3 Check Battery electrolyte

If there seems to be a problem in starting an engine due to a flat battery, carry out the checks by following the procedures below:

1. Enclosed type battery:

Check the indicator on top surface of the battery.

If the indicator shows that charge is needed, recharge the battery immediately.

2. Ordinary type battery:

Measure specific gravity of battery electrolyte, and if it shows below 1.24, recharge the battery immediately.

Refer to 6.1. for method of specific gravity measurement and recharging the battery.

5.6.4 Clean and change Air Filter Element

IMPORTANT

—— *Cleaning of Air Filter Element should be perfectly performed* ——

- Clogged or cracked or pitted element could allow entrance of dust into engine and compressor to cause earlier wear of moving parts. Periodical inspection and cleaning of element should be performed to maintain life of compressor and engine long.

- Remove both outer element "2" and "4", and clean them.
- Replace both inner element "1" and "3" once in the proportion of replacing external ones four times. The internal ones can never be reused even after they are cleaned.
- When it is found that they cannot be repaired even after being cleaned, replace the elements "1" and "2". (See 5.6.8)

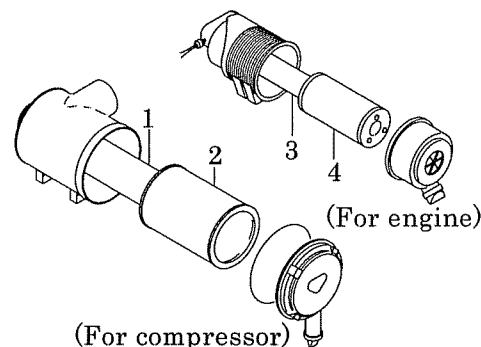

A040057

5. Periodic Inspection/Maintenance

5.6.5 Change Compressor Oil

WARNING

Refilling of compressor oil

- When you refill the separator receiver tank with compressor oil, stop the engine, and make sure that the pressure gauge indicates 0psi (0bar) and there is no residual pressure in it, and then gradually loosen the oil filler cap for refilling oil.
- Note residual pressure in the receiver tank could force both extremely hot compressed air and oil to jet out and you may be scalded or seriously injured.

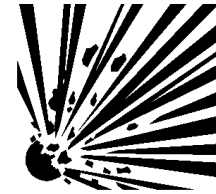

W010

IMPORTANT

Do not mix compressor oil

- Be sure to use recommended oil listed below.
- Viscosity of the oil varies depending on the temperature and other environmental conditions.
- Select one from the recommended oil listed below.

Maker and Brand of Recommended Oil

Maker	Brand
HULS	ANDEROL 3032
MOBIL	RARUS SHC 1024
TEXACO	SYN-STER DE32

- Even continuous oil replenishment cannot improve its deteriorated condition. Be sure to change the oil completely at every scheduled interval.
- Do not mix it with other brand oil, or it will cause poor performance and shorten the life of the compressor oil. (But fresh compressor oil could accept a mixture of small amount of different brands.)
- Running the unit with old and deteriorated compressor oil will cause damage to bearings, or serious accident like ignition in a separator receiver tank. Be sure to change the oil completely at every scheduled interval.

(Procedures)

Remove the oil filler cap " 2 " of separator receiver tank " 1 ".
Open drain valve " 3 " to discharge waste oil from the tank.
In case of replacement, completely discharge all the oil left in the compressor body, separator receiver tank " 1 ", pipes and oil cooler. If wasted oil is left in the unit, this residual oil will greatly shorten the life of the newly replenished oil.
Be sure to close drain valve " 3 " after the wasted oil is completely discharged.

Fill the designated quantity of new oil into the oil filler port.
After oiling, tighten the cap " 2 " in its place while paying attention not to let dust get in the tank.

Start the engine for a short while, then replenish the oil to fill shortage. Repeat this procedure for 2 to 3 times to check if the oil level has reached its appropriate point. Be careful not to overfill the oil.

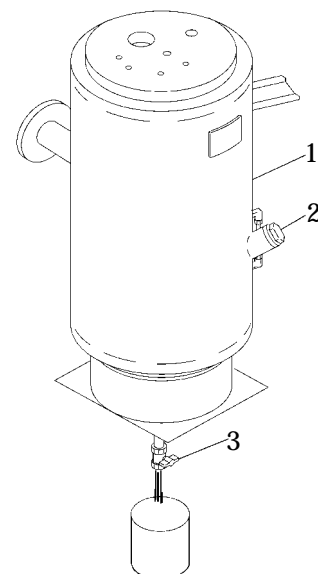

A040045

5. Periodic Inspection/Maintenance

5.6.6 Change Compressor Oil Filter

- At 300 hours for the first change and every 500 hours thereafter

IMPORTANT

Use our genuine oil filter

- Poor quality oil filters do not trap dust sufficiently and will cause damage to the bearings in a short period.

(Procedure)

Use a filter wrench to remove the cartridge " 1 " .

Spread thin film of oil on a packing " 2 " of a new cartridge " 1 " and screw it in.(For replacement parts, refer to 5.5)

After a packing touches the sealing face, tighten it 3/4 or one time turn, using filter wrench.

After installing oil filter, be sure to check for oil leak during the operation.

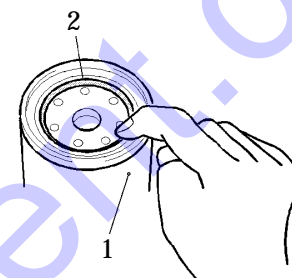

H000049

5.6.7 Clean Strainer in the Scavenging Orifice

Wash the strainer " 1 " with diesel fuel, and blow off the "dust" with air.

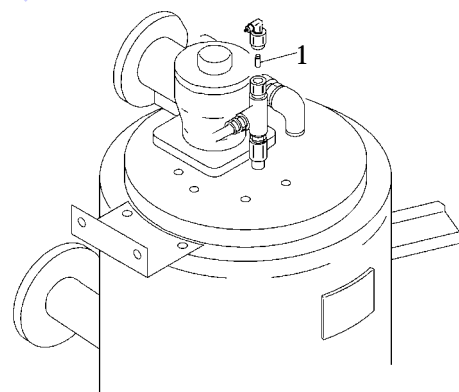

A040046

5.6.8 Change Air Filter Element

IMPORTANT

Use our genuine part

- Air filter is an important part which is crucial to machine's performance and life. Be sure to use genuine parts.

- Even before 500 hours of use, if it is used under harsh conditions, remove the element " 1 ", " 2 ", " 3 ", " 4 " check and clean it. If it is found difficult to restore it, change it a little earlier. (For replacement parts, refer to 5.5.)

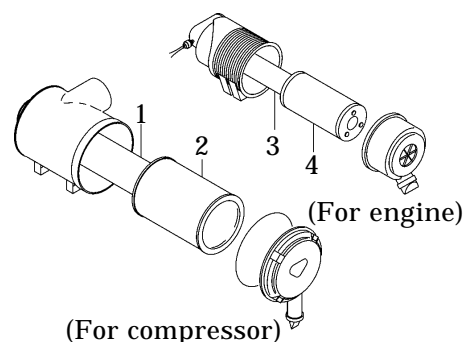

A040057

5. Periodic Inspection/Maintenance

5.6.9 Drain Fuel Tank

- Opening the drain plug “2” fitted under the fuel tank “1”, drain the condensate from the tank.
- When completely drained, firmly close the drain plug “2”.
- Drain the condensate in container “3”, dispose of condensate according to the designated regulations.

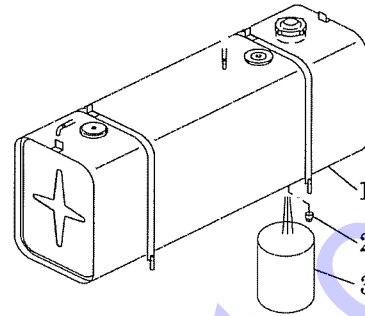

5.6.10 Change Fuel Filter

(Procedure)

- ① Remove the cartridge “1”, using a filter wrench.
- ② Spread thin film of oil on a packing “2” of a new cartridge “1” and screw it in. (For replacement parts, refer to 5.5)
- ③ After a packing touches the sealing face, tighten it by turning 2/3 times using a filter wrench.
- ④ After installing a fuel filter, be sure to check for oil leak during operation.
- ⑤ Bleed air out of fuel line. (See 4.4.3)

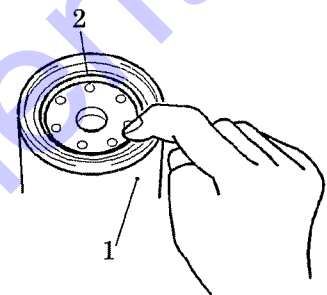

A040041

H000049

5.6.11 Change filter inside the fuel air bleeding electromagnetic pump

(Procedure)

- Remove the cap “1” by turning it counterclockwise. Then replace the filter “2” provided in it.
(For replacement parts, refer to 5.5)
- When doing this replacement, the fuel inside the filter can flow out. So place a fuel receiver under the filter beforehand.

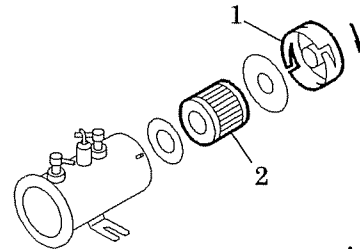

A000020

5.6.12 Clean outside of the Radiator·Oil Cooler

- When the fin tubes “1” of a radiator, an oil cooler are clogged with dust or other foreign materials, the heat exchange efficiency drops and this will raise coolant temperature and discharge air temperature. These tubes and fins should be cleaned depending on the state of clogged tubes “1” even before maintenance schedule.
- Do not use a high pressure washer to protect fin tubes “1” from being damaged.
- When the unit is used, installed near seaside and on boat board, clean the radiator using fresh water more times than once a month.

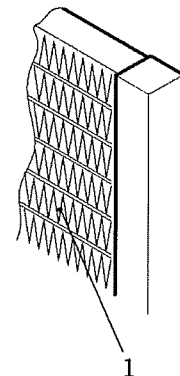

H000054

5. Periodic Inspection/Maintenance

5.6.13 Change Coolant

CAUTION

Taking off the radiator cap

- Be sure to stop the machine and allow time to cool. Then loosen the radiator cap one notch. After the coolant water is sufficiently cooled and the inner pressure is released, take the cap off. If this procedure is neglected, the inner pressure can blow off the cap. Steam jetting out of the radiator could result in causing scalding. Follow this procedure under all circumstances.



H990432

CAUTION

How to handle LLC (Antifreeze)

- LLC (Antifreeze) is a toxic material.
- When a person has drunk LLC (Antifreeze) by accident, make him vomit and see a doctor immediately.
- When a person gets LLC (Antifreeze) in his eyes, wash the eyes with clean running water and make him see a doctor immediately.
- When LLC (Antifreeze) is stored, put it in a container with an indication saying "LLC (Antifreeze) inside" and seal it up, then keep it in a place away from children.
- Beware of flames.
- Follow the designated regulations to dispose of LLC (Antifreeze).

IMPORTANT

Quality of coolant and antifreeze

- Use soft water of good quality such as tap water for coolant.
- When water with dirt, sand, and/or dust contained, or hard water such as well water (ground water) is used, this will cause deposits inside radiator or on cylinder head, and will cause engine overheat due to poor flow of coolant.
- When replacing coolant, be sure to install a coolant filter and add coolant.
- When the unit is used in a cold region and possible freezing is expected, it is recommended to use LLC (Antifreeze) for the coolant.
- Adjust mixing ratio of LLC (Antifreeze) with water according to the temperature.
- Use LLC (Antifreeze) within the range of its mixing ratio between 35 and 60%.
- If LLC (Antifreeze) in the water exceeds more than 60%, it may decrease its antifreezing effect.

Reference of LLC (Antifreeze) mixing ratio

Temperature	Mixing ratio
-4°F (-20°C)	35%
-40°F (-40°C)	55%

5. Periodic Inspection/Maintenance

(Procedure)

To drain coolant, remove cap " 2 " of header tank on radiator " 1 " top and open the drain valve " 3 " to drain it.

Also be sure to drain engine by loosening the drain plug " 4 " without fail.

After completing drainage, close the drain valve " 3 " and drain plug " 4 " and then supply coolant through the filler port of the header tank.

After coolant is filled up, run unit at unload condition for 2 or 3 minutes and stop it. Then check coolant level. When the level is low, replenish it.

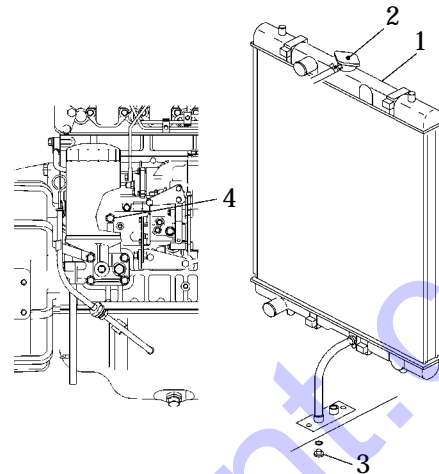

A040047

5.6.14 Supply grease to trailer spring pin

- Supply grease through grease nipples positioned at the bottom.

Grease: Chassis grease

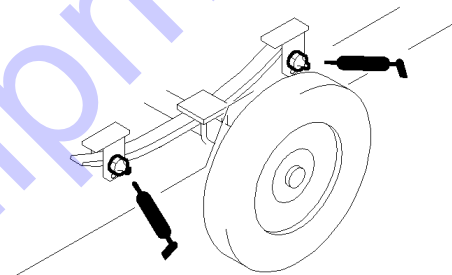

TR0260B

5.6.15 Change Oil Separator

- If even before scheduled interval of 2,000 hours operation, consumption of compressor oil is unusually high, and the differential pressure gauge of the oil separator reaches Red range, change the oil separator. (See 4.4.6)
But note that the differential pressure gauge shows correct indication only in full load operation and minimum pressure.
- Replacing oil separator ass'y " 1 " and gasket " 2 ", " 3 ".
(For part numbers, refer to 5.5).
- When replacing oil separator, contact directly us or distributor because it requires expert technical knowledge.

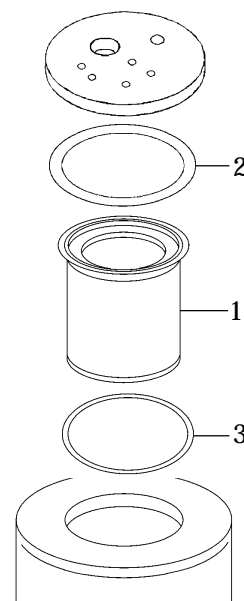

A040049-1

5. Periodic Inspection/Maintenance

5.6.16 Check Rubber hose

- Every 2,000 hours
- In case various rubber hoses for fuel system and engine lubrication system are hardened or deteriorated, replace them even before the specified replacement time.
- Replacement of the hoses requires expert technical knowledge. So contact directly us or distributor.

5.6.17 Clean the strainer provided inside the engine feed pump

- Periodically remove the strainer “1” inside the feed pump, and clean it.
- Remove the strainer “1” by loosening the joint bolt and clean it with diesel fuel oil, and also using high air pressure blow. At this time be sure to replace gasket. (For part numbers, refer to 5.5) Then after finishing all cleaning jobs, install it again in reverse steps.

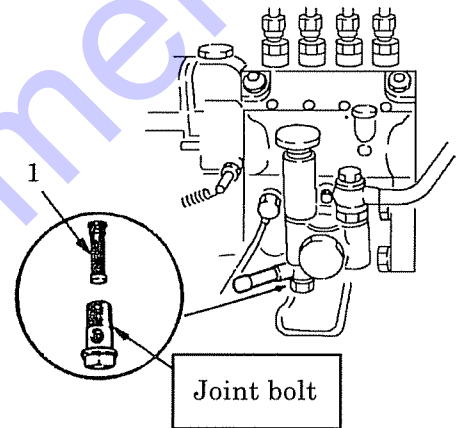

A030211

6. Maintenance/Adjustment

6.1 Maintenance of Battery



WARNING

Handling battery

- Keep flames away from battery.
- Battery may generate hydrogen gas and may explode.
- Therefore, recharging should be done at a well-ventilated place.
- Do not spark near the battery nor light a match, nor bring lit cigarette and match close to the battery.
- Do not check the battery by short-circuiting the positive and negative terminals with a metallic piece.
- Never operate the machine nor charge the batteries with the battery liquid level being kept lower than the "LOWER" level. Continuing operation at this lower level will cause deterioration of such parts as pole plates etc., and also it may cause explosion as well as reduction of battery life. Add distilled water so that the liquid level may reach the middle level between the "UPPER" and "LOWER" level without any delay.
- Do not charge the frozen battery. Otherwise it may explode. If the battery is frozen, warm it up until the battery temperature becomes 61°F to 86°F (16°C to 30°C).
- Battery electrolyte is dilute sulfuric acid. In case of mishandling, it could cause skin burning.
- When you deal with a battery, please be sure to wear protection implements, such as protection glasses and a glove.
- When such battery electrolyte contacts your clothes or skin, wash it away with large amount of water immediately.
- If the battery electrolyte gets into your eyes, wash it away immediately with plenty of water and see a doctor at once, because it is feared that eyesight might be lost.
- Dispose of battery, observing local regulations.



D004

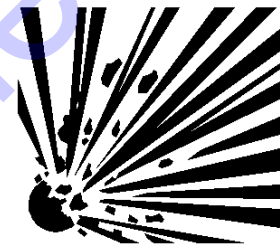

W010



TR0093



CAUTION

Do not connect the cable reversely

- If a booster cable has to be used or when cables are connected at battery replacement, be careful not to connect (+) and (-) terminals backwards. Such a wrong-connection will cause spark and damage each component.

6. Maintenance/Adjustment

6.1.1 Charge Battery

- Disconnect the cable between battery and the unit, and charge the battery with a 12V battery charger. Do not charge two batteries at the same time.
- Be sure not to connect (+) and (-) terminals backwards.
- Be sure to read the operation manual of the battery charger to know if it is applicable, before using it.

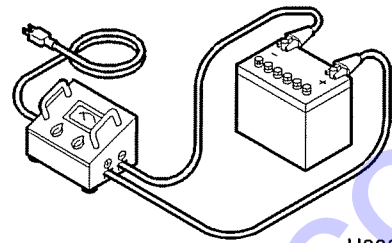

6.1.2 How to Use Booster Cable



Do not connect the cable reversely

- If a booster cable has to be used or when cables are connected at battery replacement, be careful not to connect (+) and (-) terminals backwards. Such a wrong-connection will cause spark and damage each component.

(Procedure for using a booster cable)

- ① Stop the engine.
- ② Connect one end of the (+) cable to the (+) terminal of the machine battery.
- ③ Connect the other end of the (+) cable to the (+) terminal of the external battery.
- ④ Connect one end of the (-) cable to the (-) terminal of the external battery.
- ⑤ Connect the other end of the (-) cable to the engine block of the machine.
- ⑥ Start up the engine.
- ⑦ Disconnect the booster cable by following the procedure back in the reverse order.

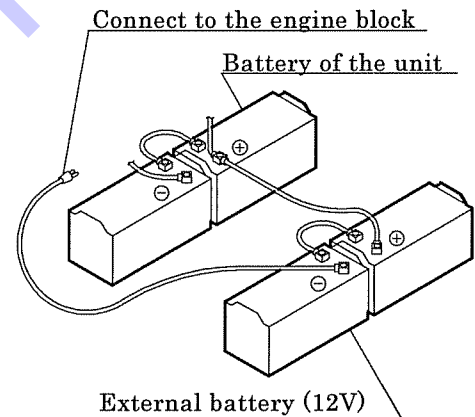

M980196E

6. Maintenance/Adjustment

6.2 Troubleshooting

- Should any trouble occur during operation, do not leave it. Investigate the cause and take appropriate measures.
- Read the manual carefully and fully understand what to do in case of trouble.
- The better you understand the construction and function of the unit, the faster you can find a problem and solution.
- This chapter describes the state, cause and countermeasures of important troubles in detail:

Symptom	Cause	Countermeasures
Low starter revolution speed.	(1) Battery malfunction.	Check battery Charge, change
Starter rotates but engine does not start.	(1) Fuel filter clogging. (2) Malfunction of fuel cut motor stopper. (3) No fuel.	Disassemble, clean, and change Check fuse Change motor stopper Check connector Replenish fuel
Discharge air pressure does not reach 100psi (6.9bar).	(1) Pressure regulator insufficient adjustment. (2) Starting unloader valve is left at its start position.	Re-adjust (Fasten) Place it at "RUN" position
Engine does not reach its maximum speed.	(1) Improper length in speed regulator rod. (2) Unloader orifice clogging. (3) Faulty speed regulator. (4) Engine trouble. (5) Fuel filter clogging.	Re-adjust Disassemble/Clean Disassemble/Check Call your nearest dealer Disassemble/Change
Revolution drops before discharge air pressure reaches 100psi (6.9bar).	(1) Pressure regulator insufficient adjustment. (2) Trouble of pressure regulator. (3) Unloader orifice clogging.	Re-adjust (Fasten) Change Disassemble/Check
Engine does not reach minimum revolution at unload.	(1) Improper length in speed regulator rod. (2) Faulty speed regulator.	Re-adjust Disassemble/Check
Safety valve relieves at unload.	(1) Pressure regulator insufficient adjustment. (2) Speed regulator diaphragm damaged. (3) Unloader valve damaged and seat malfunction. (4) Faulty safety valve. (5) Improper length of speed regulator rod	Re-adjust (loosen) Change Change Change Re-adjust (elongate)
Oil mixes in Air. (Poor oil separation)	(1) Scavenging orifice strainer clogging. (2) Low discharge pressure. (3) Oil separator deteriorated.	Disassemble/Clean Disassemble/pressure Control valve/check Disassemble/Change
Insufficient free air delivery.	(1) Air filter element clogging. (2) Unloader valve cannot fully open. (3) Engine does not reach rated speed.	Clean element or change Call your nearest dealer

6. Maintenance/Adjustment

Symptom	Cause	Countermeasures
Engine oil pressure lamp goes on.	(1) Engine oil shortage. (2) Engine oil filter clogging. (3) Malfunction of engine oil pump (4) Faulty oil pressure switch. (5) Loosened or disconnected wiring or connector.	Replenish oil Change Change Change Check/Fasten
Coolant temp. lamp goes on.	(1) Radiator clogging. (2) Faulty thermostat. (3) Faulty coolant temp. switch. (4) Low coolant level. (5) Fan belt slippage. (6) Loose wiring, connectors and disconnection	Clean Change Change Replenish Re-adjust tension Check/retighten
Discharge air temp. lamp goes on.	(1) Oil cooler clogging. (2) Oil filter clogging. (3) Faulty discharged air temp. switch. (4) Loose wiring connectors and disconnection. (5) Slippage of fan belt. (6) Shortage of compressor oil. (7) Malfunction of by-pass valve.	Clean Change Check/inspect Check and retighten Re-adjust tension Replenish oil Check/change
Engine speed down lamp goes on.	(1) Speed regulator insufficient adjustment. (2) Trouble of controller.	Re-adjust Change
Fuel residual level lamp goes on.	(1) Fuel runs short. (2) Malfunction of fuel oil level drop sending unit (3) Loose wiring connectors and disconnection	Refueling Check/change Check and retighten

- Contact your nearest dealer if you find it difficult to repair by yourselves.
- Refer to the engine operation manual for trouble concerning the engine.

7. Storage of the Unit

7.1 Preparation for Long-term Storage

When the unit is to be kept unused in storage for a long time, be sure to follow the preparations below and put the unit in a dry and less dusty place.

- Put the unit in a temporary cabin if it is stored outside. Avoid leaving the unit outside with a sheet cover directly on the paint for a long time, or this will cause rust to the unit.
- Perform the following treatments at least once every three months.

(Procedure)

Drain existing lubricant from the engine oil pan. Pour new lubricant in the engine to clean its inside. After running it for a while, drain it again.

Spread lubricant on moving parts like speed regulator and rod end, beforehand.

Completely charge the battery and disconnect grounding wires. Remove the battery from the unit, if possible, and store it in a dry place. (Charge the battery at least once every month.)

Drain coolant and fuel from the unit.

Seal the engine, air-intake port and other openings like the muffler with a vinyl sheet, packing tape, etc., to prevent moisture and dust from getting in the unit.

Be sure to repair any trouble and maintain the unit so that it will be ready for the next operation.

8. Specifications

8.1 Specifications

Length	in.(mm)	142(3,600)	Compressor	Type		Single-stage oil cooled, screw type compressor
Length (draw-bar excluded)	in.(mm)	95 (2,445)		Free air delivery	cfm(m ³ /min)	400 (11.3)
Width	in.(mm)	78(1,975)		Working pressure	psi(bar)	100 (6.9)
Height	in.(mm)	68(1,720)		Maximum pressure	psi(bar)	150 (10.3)
Dry weight	lb(kg)	4,004 (1,820)		Lubricating system		Forced Lubrication by compressed pressure.
Weight in operating condition	lb(kg)	4,488 (2,020)		Driving system		Direct driving with rubber coupling.
Fuel tank capacity	gal.(L)	43.6(165)		Receiver tank capacity	cu in.(m ³)	5,980 (0.098)
			Engine	Lubrication oil capacity	gal.(L)	13.5 (51)
				Model		ISUZU DD-4BG1-T
				Type		4-cycle, water-cooled, direct injection type with turbo charged
				Number of cylinders, bore × stroke	in. (mm)	4-4.1 × 4.9 (4-105 × 125)
				Total displacement	cu in.(L)	264 (4.329)
				Rated output	hp/rpm (kW/min ⁻¹)	108.5/2,400 (80.9/2,400)
				Lubricating oil capacity	gal.(L)	3.4 (13)
			Coolant capacity (including radiator)	gal.(L)	3.4 (13)	
			Battery		80D26R × 2	

8.2 Outline drawing

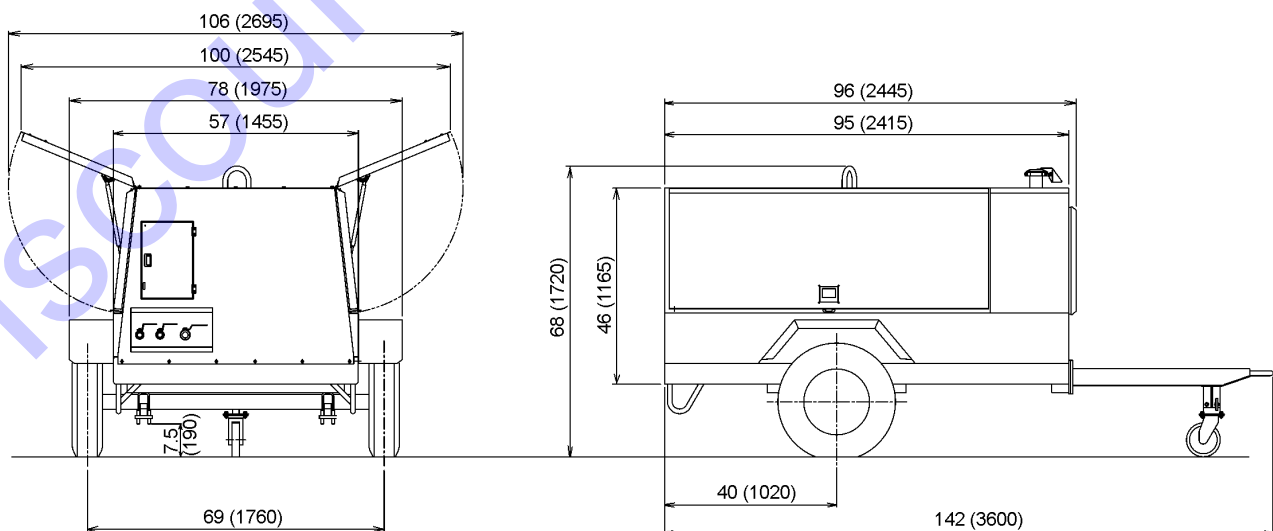

A040048

9. Wiring Diagram

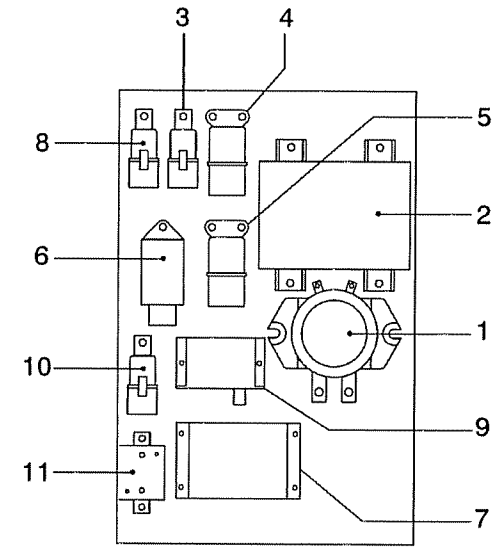
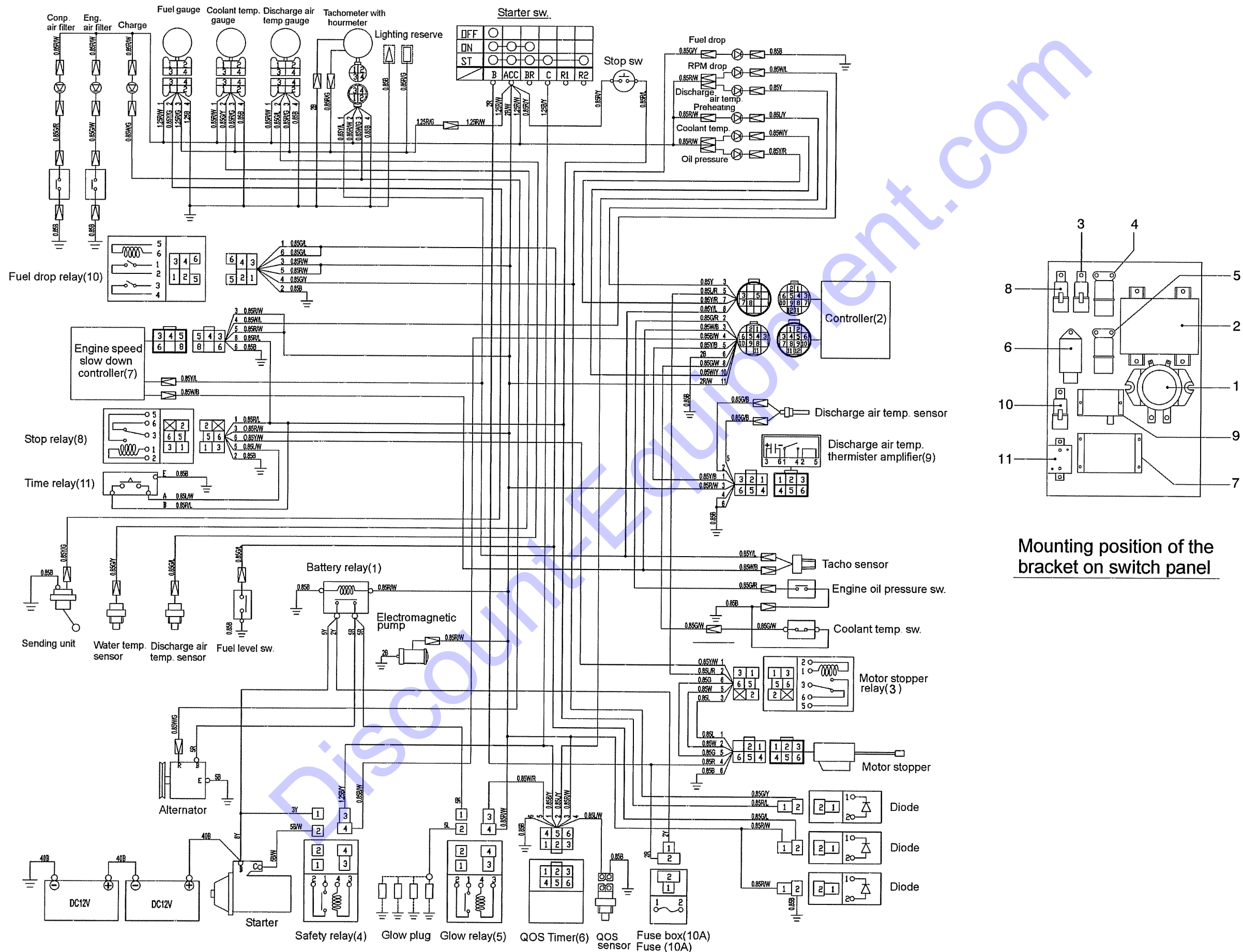

Mounting position of the bracket on switch panel

10. Piping Diagram

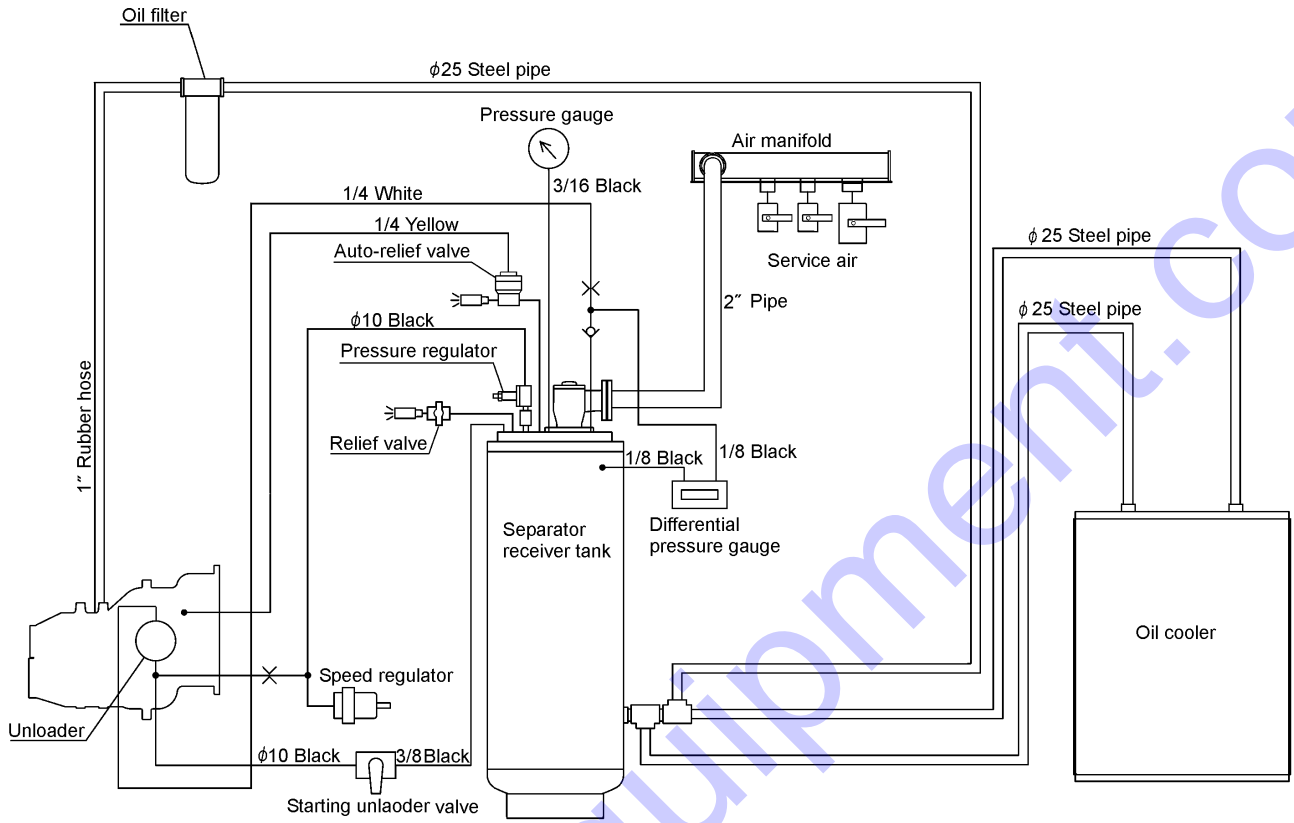

A040051



www.discount-equipment.com

Discount-Equipment.com

AIRMAN

HOKUETSU INDUSTRIES CO., LTD.