

**GENERAC®**

**MOBILE**

*Owner's Manual*  
*Light Tower*

**MLT6SMD**

**S/N 3003218476 and above**

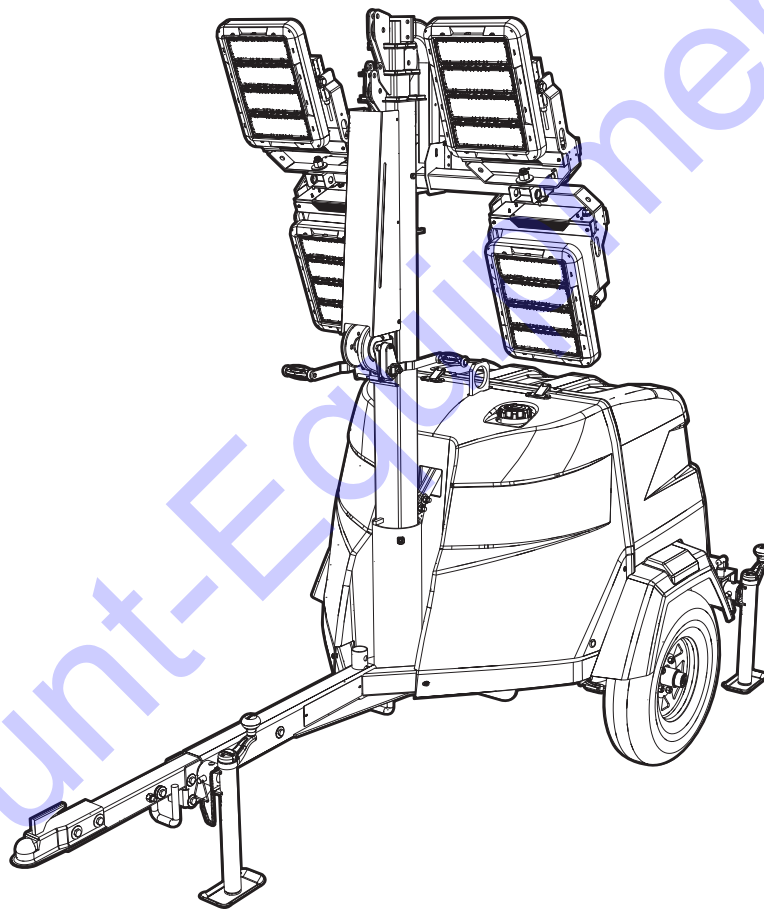

**Discount  
Equipment**

[www.discount-equipment.com](http://www.discount-equipment.com)

**SAVE THIS MANUAL FOR FUTURE REFERENCE**

# **Discount Equipment**

Discount-Equipment.com is your online resource for commercial and industrial quality parts and equipment sales.

## **Locations:**

Florida (West Palm Beach): [561-964-4949](tel:561-964-4949)

Outside Florida TOLL FREE: [877-690-3101](tel:877-690-3101)

**Need parts?** Check out our website at [www.discount-equipment.com](http://www.discount-equipment.com)

## **Can't find what you need?**

Click on this link: <http://www.discount-equipment.com/category/5443-parts/> and fill out the request form.

Please have the machine model and serial number available in order to help us get you the correct parts. One of our experienced staff members will get back to you with a quote for the right part that your machine needs.

We sell worldwide for the brands: Genie, Terex, JLG, MultiQuip, Mayco, Toro/Stone, Diamond Products, Magnum, Airman, Mustang, Power Blanket, Nifty Lift, Atlas Copco, Chicago Pneumatic, Allmand Brothers, Essick, Miller Spreader, Skyjack, Lull, Skytrak, Tsurumi, Husquvarna/Target, Whiteman-Concrete/Mortar, Stow-Concrete/Mortar, Baldor, Wacker, Sakai, Snorkel, Upright, Mi-T-M, Sullair, Neal, Basic, Dynapac, MBW, Weber, Bartell, Bennar Newman, Haulotte, Ditch Runner, Blaw-Knox, Himoina, Best, Buddy, Crown, Edco, Wyco, Bomag, Laymor, Terremite, Barreto, EZ Trench, Takeuchi, Basic, Bil-Jax, Curtis, Gehl, Heli, Honda, ICS/PowerGrit, Puckett, Waldon, ASV, IHI, Partner, Imer, Clipper, MMD, Koshin, Rice, Gorman Rupp, CH&E, Cat Pumps, Comet, General Pump, Giant, AMida, Coleman, NAC, Gradall, Square Shooter, Kent, Stanley, Tamco, Toku, Hatz, Kohler, Robin, Wisconsin, Northrock, Oztec, Toker TK, Rol-Air, Small Line, Wanco, Yanmar

**New Equipment - Used Equipment - Rental Equipment - Parts and Accessories**

# **Discount Equipment**

[www.discount-equipment.com](http://www.discount-equipment.com)

**561-964-4949**

Parts: [wbparts@Discount-Equipment.com](mailto:wbparts@Discount-Equipment.com)

Sales: [info@Discount-Equipment.com](mailto:info@Discount-Equipment.com)

**Use this page to record important information about your light tower.**

Unit Model Number	
Unit Serial Number	
Engine Model Number	
Engine Serial Number	
Generator Model Number	
Generator Serial No.	

Record the information found on your unit data label on this page. See [Unit Serial Number Locations](#).

Engine and generator serial numbers are located on separate data plates affixed to the engine and generator respectively. When contacting a Generac Mobile Products Authorized Service Dealer (ASD) about parts and service, always provide the unit model and serial number.

**Operation and Maintenance:** Proper maintenance and care of the light tower ensures a minimum number of problems and keeps operating expenses at a minimum. It is the operator's responsibility to perform all safety checks, to verify that all maintenance for safe operation is performed promptly, and to have the equipment checked periodically by a GMP ASD. Normal maintenance, service, and replacement of parts are the responsibility of the owner/operator and, as such, are not considered defects in materials or workmanship within the terms of the warranty. Individual operating habits and usage may contribute to the need for additional maintenance or service.

 **WARNING**

**CANCER AND REPRODUCTIVE HARM**

[www.P65Warnings.ca.gov](http://www.P65Warnings.ca.gov).

(000393a)

 **WARNING**

Breathing diesel engine exhaust exposes you to chemicals known to the State of California to cause cancer and birth defects or other reproductive harm.

- Always start and operate the engine in a well-ventilated area.
- If in an enclosed area, vent the exhaust to the outside.
- Do not modify or tamper with the exhaust system.
- Do not idle the engine except as necessary.

For more information go to [www.P65Warnings.ca.gov/diesel](http://www.P65Warnings.ca.gov/diesel).

(000394)

# Table of Contents

## **Section 1: Introduction and Safety**

<b>Introduction</b> .....	1
Read This Manual Thoroughly .....	1
<b>Safety Rules</b> .....	1
How to Obtain Service .....	1
<b>General Hazards</b> .....	2
<b>Explosion and Fire Hazards</b> .....	2
<b>Trailer Hazards</b> .....	2
<b>Electrical Hazards</b> .....	3
<b>Battery Hazards</b> .....	3
<b>Fuel Hazards</b> .....	4
<b>Engine Safety</b> .....	4
<b>Operating Safety</b> .....	5
Positioning the Unit .....	5
Starting the Unit .....	5
Raising and Lowering the Mast .....	5
<b>Service Safety</b> .....	6
<b>Towing Safety</b> .....	6
Hitch and Coupling .....	6
Running Lights .....	6
Wheels and Tires .....	6
Safe Towing Techniques .....	6
<b>Reporting Trailer Safety Defects</b> .....	7
<b>Safety and Operating Decals</b> .....	8

## **Section 2: General Information**

<b>Specifications</b> .....	13
<b>Unit Serial Number Locations</b> .....	14
<b>Trailer Tongue Storage and Tow Positions</b> .....	15
Place Trailer Tongue in Tow Position .....	15
Place Trailer Tongue in Storage Position .....	16
<b>Unit Dimensions</b> .....	17
<b>Component Locations</b> .....	18
<b>Control Panel</b> .....	20
Control Panel Features and Functions .....	21
<b>ECOSpeed Engine</b> .....	21
<b>PowerZone—DLA</b> .....	22
Controller Features and Functions .....	22
Operator Screens .....	23

## **Section 3: Operation**

<b>Light Tower Setup</b> .....	29
<b>Prestart Checklist</b> .....	30
<b>Raising the Mast—Manual Winch</b> .....	30
<b>Raising the Mast—Electric Winch (If Equipped)</b> .....	31
<b>Preparing for Start-Up</b> .....	32
Select Auto Mode or Manual Mode .....	32
Configure for Intended Use .....	32
<b>Manually Starting the Unit</b> .....	32
<b>Light Operation</b> .....	33
<b>Engine Derating</b> .....	33
<b>Wet Stacking</b> .....	33
<b>Dusk to Dawn Sensor</b> .....	34
<b>Customer Convenience Receptacles</b> .....	34
<b>Shutting Down the Unit</b> .....	34
<b>Automatic Shutdown</b> .....	34
<b>Tandem Tow (If Equipped)</b> .....	34
<b>Telemetry (If Equipped)</b> .....	35
<b>Spark Arrester (If Equipped)</b> .....	35
<b>Lowering the Mast—Manual Winch</b> .....	35
<b>Lowering the Mast—Electric Winch (If Equipped)</b> .....	35
Electrically Lowering the Mast .....	35
Manually Lowering the Mast .....	36
<b>Lower Radiator Hose Heater (If Equipped)</b> .....	36
Use and Maintenance .....	36
<b>Towing the Unit</b> .....	36
<b>Lifting the Unit</b> .....	37
<b>Tying Down the Unit</b> .....	37

---

## **Section 4: Maintenance**

<b>Emissions Information</b> .....	<b>39</b>
<b>Daily Walk-Around Inspection</b> .....	<b>39</b>
<b>General Maintenance</b> .....	<b>39</b>
Preparing for Service .....	39
Cleaning the Unit .....	39
Inspecting the Unit .....	39
<b>Basic Maintenance Schedule</b> .....	<b>40</b>
<b>Resetting the Maintenance Alarms</b> .....	<b>41</b>
<b>Winch Use, Operation, and Maintenance— Manual</b> .....	<b>41</b>
Prior to Use .....	41
Operation .....	41
Maintenance .....	41
<b>Winch Use, Operation, and Maintenance— Electric</b> .....	<b>41</b>
Winch Mechanical Brake .....	42
<b>Trailer Wheel Bearings</b> .....	<b>42</b>
<b>Jack Maintenance</b> .....	<b>42</b>

## **Section 5: Troubleshooting**

<b>General Troubleshooting</b> .....	<b>43</b>
--------------------------------------	-----------

## **Section 6: Wiring Diagrams**

<b>AC Wiring</b> .....	<b>45</b>
<b>DC Wiring—Control Box</b> .....	<b>46</b>
<b>DC Wiring</b> .....	<b>47</b>
<b>DC Wiring—Electric Winch Option</b> .....	<b>48</b>
<b>Trailer Wiring</b> .....	<b>49</b>

## **Section 7: Service Log**

# Section 1: Introduction and Safety

## Introduction

Thank you for purchasing a Generac Mobile Products, LLC product. This unit has been designed to provide high-performance, efficient operation, and years of use when maintained correctly.

The information in this manual is accurate based on products produced at the time of publication. The manufacturer reserves the right to make technical updates, corrections, and product revisions at any time without notice.

## Read This Manual Thoroughly



### **WARNING**

Consult Manual. Read and understand manual completely before using product. Failure to completely understand manual and product could result in death or serious injury. (000100a)

The owner is responsible for proper maintenance and safe use of the equipment. Comply with regulations the Occupational Safety and Health Administration (OSHA) has established, or with equivalent standards. Also, verify the unit is applied, used, and maintained in accordance with the manufacturer's instructions and recommendations. Do nothing to alter safe application/usage and render the unit in noncompliance with the aforementioned codes, standards, laws, and regulations.

Save these instructions for future reference. This manual contains important instructions for the unit to be followed during setup, operation and maintenance of the unit and battery. ALWAYS supply this manual to any individual that will use this machine.

## Safety Rules

The manufacturer cannot anticipate every possible circumstance that might involve a hazard. The alerts in this manual, and on tags and decals affixed to the unit, are not all inclusive. If using a procedure, work method, or operating technique that the manufacturer does not specifically recommend, verify that it is safe for others and does not render the equipment unsafe.

Throughout this publication, and on tags and decals affixed to the unit, DANGER, WARNING, CAUTION, and NOTE blocks are used to alert personnel to special instructions about a particular operation that may be hazardous if

performed incorrectly or carelessly. Observe them carefully. Alert definitions are as follows:

### **DANGER**

Indicates a hazardous situation which, if not avoided, will result in death or serious injury.

(000001)

### **WARNING**

Indicates a hazardous situation which, if not avoided, could result in death or serious injury.

(000002)

### **CAUTION**

Indicates a hazardous situation which, if not avoided, could result in minor or moderate injury.

(000003)

**NOTE:** Notes contain additional information important to a procedure and will be found within the regular text of this manual.

These safety alerts cannot eliminate the hazards that they indicate. Common sense and strict compliance with the special instructions while performing the action or service are essential to preventing accidents.

## How to Obtain Service

When the unit requires servicing or repairs, contact a Generac Mobile Products Authorized Dealer for assistance. Service technicians are factory-trained and are capable of handling all service needs. When contacting an ASD about parts and service, always supply the complete model number and serial number of the unit as given on its data decal located on the unit. Record the model number and serial numbers in the spaces provided on the inside front cover of this manual.

## General Hazards



**⚠ DANGER**

Asphyxiation. Running engines produce carbon monoxide, a colorless, odorless, poisonous gas. Carbon monoxide, if not avoided, will result in death or serious injury. (000103)



**⚠ WARNING**

Hearing Loss. Hearing protection is recommended when using this machine. Failure to wear hearing protection could result in permanent hearing loss. (000107)



**⚠ WARNING**

Moving Parts. Keep clothing, hair, and appendages away from moving parts. Failure to do so could result in death or serious injury. (000111)



**⚠ WARNING**

Hot Surfaces. When operating machine, do not touch hot surfaces. Keep machine away from combustibles during use. Hot surfaces could result in severe burns or fire. (000108)

**⚠ WARNING**

Risk of injury. Do not operate or service this machine if not fully alert. Fatigue can impair the ability to service this equipment and could result in death or serious injury. (000215)



**⚠ WARNING**

Risk of burns. Allow engine to cool before draining oil or coolant. Failure to do so could result in death or serious injury. (000139)

**⚠ WARNING**

Personal Injury. Do not use lifting eye if there are signs of damage or corrosion. Doing so could result in death, serious injury, or property damage. (000433)

**⚠ WARNING**

Personal Injury. Do not use lifting eye other than as directed. Doing so could result in death, serious injury, or property damage. (000434)

## Explosion and Fire Hazards



**⚠ DANGER**

Explosion and Fire. Fuel and vapors are extremely flammable and explosive. Add fuel in a well ventilated area. Keep fire and spark away. Failure to do so will result in death or serious injury. (000105)



**⚠ WARNING**

Risk of Fire. Unit must be positioned in a manner that prevents combustible material accumulation underneath. Failure to do so could result in death or serious injury. (000147)



**⚠ WARNING**

Risk of Fire. Hot surfaces could ignite combustibles, resulting in fire. Fire could result in death or serious injury. (000110)

## Trailer Hazards

**⚠ WARNING**

Trailer must be securely coupled to the hitch and the chains correctly attached. Uncoupled or unchained towing could result in death or serious injury. (000233)

**⚠ WARNING**

Do not operate this unit while transporting. Doing so could result in death or serious injury. (000231)

**⚠ WARNING**

Crushing hazard. Verify unit is properly secured and on level ground. An unsecured unit can suddenly roll or move, causing death or serious injury. (000234a)

**⚠ WARNING**

Property or Equipment Damage. Tighten wheel lug nuts after first 50 miles to factory specifications. Failure to do so could result in death, serious injury, property or equipment damage. (000235)

## Electrical Hazards



**⚠ DANGER**

Electrocution. In the event of electrical accident, immediately shut power OFF. Use non-conductive implements to free victim from live conductor. Apply first aid and get medical help. Failure to do so will result in death or serious injury. (000145)



**⚠ DANGER**

Electrocution. Water contact with a power source, if not avoided, will result in death or serious injury.

(000104)



**⚠ DANGER**

Electrocution. Contact with bare wires, terminals, and connections while generator is running will result in death or serious injury.

(000144)



**⚠ DANGER**

Electrocution. Verify electrical system is properly grounded before applying power. Failure to do so will result in death or serious injury.

(000152)



**⚠ DANGER**

Electrocution. Do not wear jewelry while working on this equipment. Doing so will result in death or serious injury.

(000188)



**⚠ DANGER**

Electrocution. DO NOT use the unit if electrical cord is cut or worn through. Doing so will result in death or serious injury.

(000263a)

## Battery Hazards



**⚠ DANGER**

Electrocution. Do not wear jewelry while working on this equipment. Doing so will result in death or serious injury.

(000188)



**⚠ WARNING**

Explosion. Batteries emit explosive gases while charging. Keep fire and spark away. Wear protective gear when working with batteries. Failure to do so could result in death or serious injury.

(000137a)



**⚠ WARNING**

Explosion. Do not dispose of batteries in a fire. Batteries are explosive. Electrolyte solution can cause burns and blindness. If electrolyte contacts skin or eyes, flush with water and seek immediate medical attention.

(000162)



**⚠ WARNING**

Risk of burn. Do not open or mutilate batteries. Batteries contain electrolyte solution which can cause burns and blindness. If electrolyte contacts skin or eyes, flush with water and seek immediate medical attention.

(000163a)

**⚠ WARNING**

Environmental Hazard. Always recycle batteries at an official recycling center in accordance with all local laws and regulations. Failure to do so could result in environmental damage, death or serious injury.

(000228)

Always recycle batteries in accordance with local laws and regulations. Contact your local solid waste collection site or recycling facility to obtain information on local recycling processes. For more information on battery recycling, visit the Battery Council International website at: <http://batteryCouncil.org>



## Fuel Hazards



**⚠ DANGER**

Explosion and fire. Fuel and vapors are extremely flammable and explosive. No leakage of fuel is permitted. Keep fire and spark away. Failure to do so will result in death or serious injury. (000192)



**⚠ DANGER**

Explosion and Fire. Fuel and vapors are extremely flammable and explosive. Keep fire and spark away. Failure to do so will result in death or serious injury. (000168)



**⚠ DANGER**

Risk of fire. Allow fuel spills to completely dry before starting engine. Failure to do so will result in death or serious injury. (000174)



**⚠ DANGER**

Explosion and Fire. Fuel and vapors are extremely flammable and explosive. Add fuel in a well ventilated area. Keep fire and spark away. Failure to do so will result in death or serious injury. (000105)

- **DO NOT** operate with the fuel tank cap loose or missing.

## Engine Safety

Internal combustion engines present special hazards during operation and fueling. Failure to follow the safety guidelines described below could result in severe injury or death. Read and follow all safety alerts described in the engine operator's manual. A copy of this manual was supplied with the unit when it was shipped from the factory.



**⚠ DANGER**

Asphyxiation. Running engines produce carbon monoxide, a colorless, odorless, poisonous gas. Carbon monoxide, if not avoided, will result in death or serious injury. (000103)



**⚠ DANGER**

Asphyxiation. Do not operate unit without a properly functioning exhaust system. Doing so will result in death or serious injury. (000340)



**⚠ WARNING**

Fire risk. Fuel and vapors are extremely flammable. Do not operate indoors. Doing so could result in death, serious injury, or property or equipment damage. (000281)



**⚠ WARNING**

Risk of fire. Never operate engine without the air cleaner installed. Operating engine without the air cleaner could result in death or serious injury. (000249)



**⚠ WARNING**

Explosion and Fire. Do not smoke while refueling unit. Failure to do so could result in death, serious injury, or property or equipment damage. (000284a)

**⚠ CAUTION**

Equipment damage. Do not clean air filter elements. Contaminants may remain after cleaning, shortening air filter service life. Doing so could result in engine or equipment damage. (000317)

- **DO NOT** run engine indoors or in an area with poor ventilation. Verify engine exhaust cannot seep into closed rooms or ventilation equipment.
- Shut the engine down if any of the following conditions exist during operation:
  - Abnormal change in engine speed.
  - Loss of electrical output.
  - Equipment connected to the unit overheats.
  - Sparking occurs.
  - Engine misfires or there is excessive engine/generator vibration.
  - Protective covers are loose or missing.
  - Ambient air temperature is above 120 °F (49 °C).

## Operating Safety

### Positioning the Unit



#### **⚠ DANGER**

High Voltage. Verify area above unit is clear of overhead wires and obstructions. Contact with high-voltage power lines will result in death or serious injury. (000260a)



#### **⚠ WARNING**

Risk of Fire. Unit must be positioned in a manner that prevents combustible material accumulation underneath. Failure to do so could result in death or serious injury. (000147)

#### **⚠ WARNING**

Equipment and property damage. Do not operate unit on uneven surfaces, or areas of excessive moisture, dirt, dust or corrosive vapors. Doing so could result in death, serious injury, property and equipment damage. (000250)

- If the unit is equipped with a frame grounding stud, follow any local, state, and National Electrical Code (NEC) guidelines when connecting.

### Starting the Unit



#### **⚠ DANGER**

Electrocution. DO NOT use the unit if electrical cord is cut or worn through. Doing so will result in death or serious injury. (000263a)

#### **⚠ WARNING**

Equipment damage. Do not attempt to start or operate a unit in need of repair or scheduled maintenance. Doing so could result in serious injury, death, or equipment failure or damage. (000291)



#### **⚠ WARNING**

Burn hazard. Never operate lights with a damaged or missing lens cover. Lamps are hot and pressurized while in use. Unprotected lamps can shatter, causing severe injury. (000277)

### Raising and Lowering the Mast



#### **⚠ WARNING**

Electrocution. Do not set up or operate this unit if severe weather is expected. Lightning strikes can kill or cause severe injury even if you are not touching the unit. (000296)



#### **⚠ WARNING**

Do not set up the unit if high winds are expected. High winds can cause the unit to tip or fall, causing severe injury or machine damage. (000297)

#### **⚠ WARNING**

Personal Injury. Stop immediately if the mast hangs up or the winch cable develops slack. Excess slack could cause the mast to collapse, resulting in personal injury or equipment damage. (000265)

#### **⚠ WARNING**

Tipping hazard. Extend the outriggers and level the unit before raising the mast. Keep the outriggers extended while the mast is up. Failure to do so could cause the unit to tip and fall and could result in death or serious injury. (000266)



#### **⚠ WARNING**

Burn Hazard. Allow bulb fixture to cool 10-15 minutes before handling or lowering mast. Failure to do so could result in serious injury. (000358)

- Keep area around the unit clear of people while raising and lowering the mast.
- **ALWAYS** lower the mast when not in use.

## Service Safety

This unit uses high voltage circuits capable of causing serious injury or death. Only a qualified and licensed electrician should troubleshoot or repair problems occurring in this equipment.



### ⚠️ WARNING

Electrocution. Potentially lethal voltages are generated by this equipment. Render the equipment safe before attempting repairs or maintenance. Failure to do so could result in death or serious injury.

(000187)

### ⚠️ WARNING

Accidental start-up. Disconnect negative battery terminal before servicing to prevent accidental engine rotation. Failure to do so could result in death or serious injury.

(000148a)

### ⚠️ CAUTION

Personal injury. Wear appropriate personal protective equipment at all times while operating and servicing unit. Failure to do so could result in personal injury.

(000419)

- Before servicing the unit, verify the control power switch and circuit breakers are OFF (O), and the negative (-) terminal on the battery is disconnected. **DO NOT** perform even routine service (oil/filter changes, cleaning, etc.) unless all electrical components are shut down.
- **ALWAYS** use extreme caution when servicing this unit in damp conditions. Do not service the unit if skin or clothing is wet. Do not allow water to collect around the base of the unit.
- **DO NOT** wash the unit with high pressure hoses, power washers, or steam cleaners. Water may collect in the unit, causing damage to electrical parts.
- Replace all missing and hard to read decals. Decals provide important operating instructions and warn of dangers and hazards.
- Only use mild soap and water to clean the lens covers. Other chemicals may damage the lens covers.

## Towing Safety

Towing a trailer requires care. Both the trailer and vehicle must be in good condition and securely fastened to each other to reduce the possibility of an accident. Some states require that large trailers be registered and licensed. Contact your local Department of Transportation office to check on license requirements for your particular unit.

### Hitch and Coupling

#### ⚠️ WARNING

Personal injury. Trailer must be securely coupled to the hitch with the chains correctly attached. Uncoupled or unchained towing could result in death or serious injury.

(000233a)

#### ⚠️ WARNING

Property or equipment damage. Do not alter the trailer. Alterations can damage essential safety items. Doing so could result in death, serious injury, or property or equipment damage.

(000285)

- Verify the hitch and coupling on the towing vehicle are rated greater than or equal to the trailer's gross vehicle weight rating (GVWR).
- **DO NOT** tow trailer using defective parts. Inspect the hitch and coupling for wear or damage.
- Before towing the trailer, verify the weight of the trailer is equal across all tires. On trailers with adjustable height hitches, adjust the angle of the trailer tongue to keep the trailer as level as possible.

### Running Lights

Verify directional and brake lights on the trailer are connected and working correctly.

### Wheels and Tires

- Inspect trailer tires for wear and correct inflation.
- Verify wheel lug nuts are present and tightened to the specified torque.

### Safe Towing Techniques

- Practice turning, stopping, and backing up in an area away from heavy traffic prior to transporting the unit.
- Maximum recommended speed for highway towing is 45 mph (72 km/h). Recommended off-road towing speed is 10 mph (16 km/h) or less, depending on terrain.
- When towing, maintain extra space between vehicles and avoid soft shoulders, curbs, and sudden lane changes.

## Reporting Trailer Safety Defects

If you believe your trailer has a defect which could cause a crash or could cause injury or death, you should immediately inform the National Highway Traffic Safety Administration (NHTSA) in addition to notifying Generac Mobile Products, LLC.

If NHTSA receives similar complaints, it may open an investigation, and if it determines a safety defect exists in a group of vehicles, it may order a recall and remedy campaign. However, NHTSA cannot become involved in an individual problem between you, your dealer, or Generac Mobile Products, LLC.

To contact NHTSA, you may either call the Auto Safety Hotline toll-free at 1-888-327-4236 (TTY:1-800-424-9153), go to <http://www.safercar.gov>; or write to:

Administrator  
NHTSA  
1200 New Jersey Avenue S.E.  
Washington, DC 20590

You can also obtain other information about motor vehicle safety from <http://www.safercar.gov>.

## Safety and Operating Decals

See [Figure 1-1](#) through [Figure 1-3](#). This unit features numerous safety and operating decals. These decals provide important operating instructions and warn of dangers and hazards. The following diagrams illustrate decal locations and descriptions.

Replace any missing or hard-to-read decals and use care when washing or cleaning the unit. Decal part numbers can be found in the parts manual.

ID	Description	ID	Description
1	Stowed Position	14	Safety Alert—Read Owner's Manual
2	Warning—Do Not Retract Outriggers With Tower Up	15	Warning—Electrical Storms and High Wind
3	Notice—Avoid Tangling Winch Cable	16	Danger—Do Not Operate Beneath Electrical Wires, In Electrical Storms, or In High Winds. Read Owner's Manual. Do Not Tow With Mast Raised.
4	Electric Shock Hazard	17	Warning—Hot Surface
5	Lifting Point	18	Warning—Pressurized Liquid
6	Forklift and Tie-Down Point	19	Disconnect Battery Before Servicing
7	Owner's Manual Location	20	Warning—Do Not Remove Guard. Hot Surface, Entanglement, and Cutting Hazards.
8	Engine Operation	21	Warning—Cutting Hazard
9	Danger—Fuel and Fueling Hazards	22	Warning—High Temperature: Do Not Remove Guard
10	Ultra Low Sulfur Diesel Fuel Only	23	Electrical Ground Connection
11	Not A Step	24	Neutral Bonded to Frame
12	Tie-Down Point	25	Setup and Take-Down Instructions
13	Towing Instructions	—	—

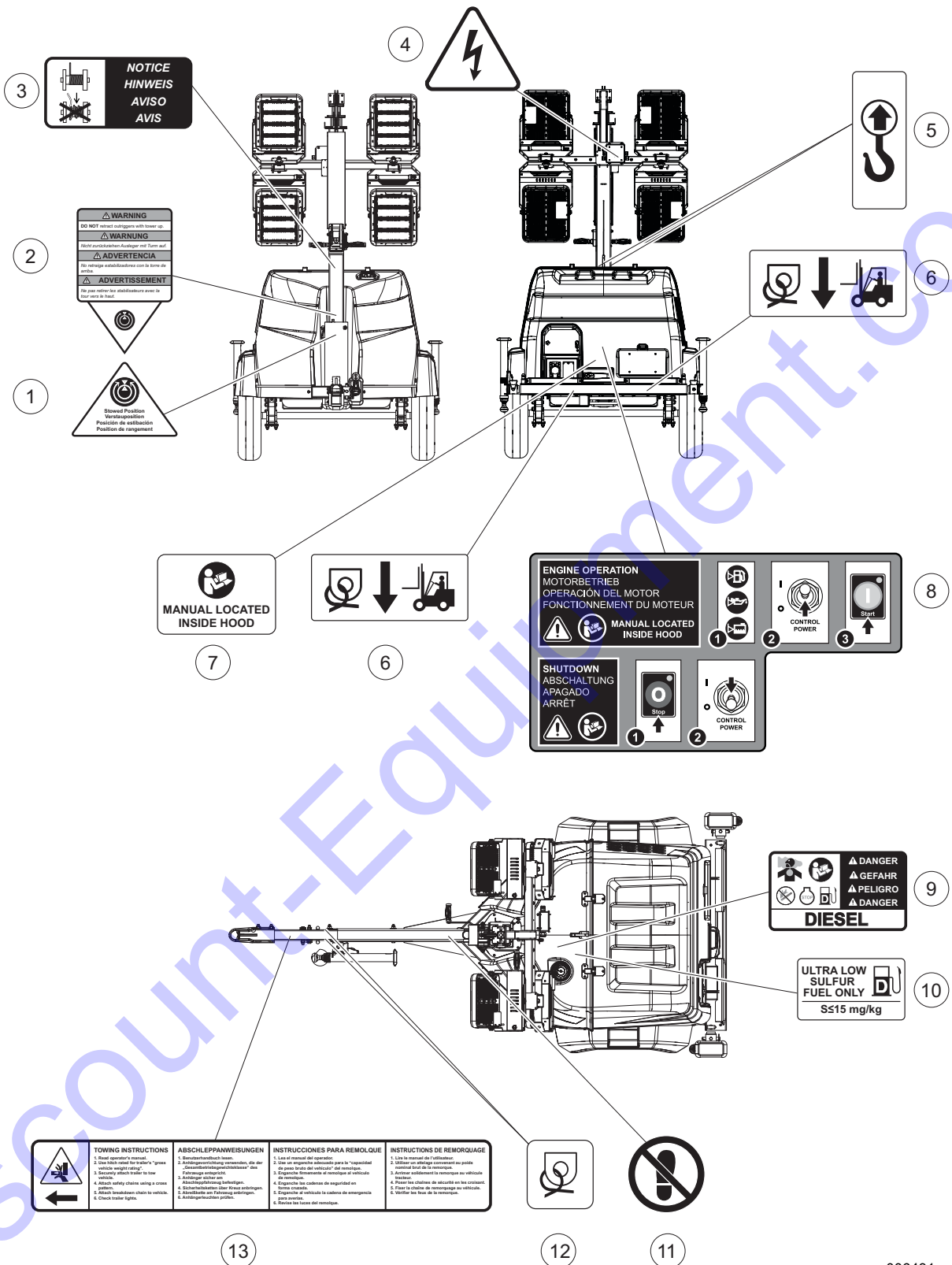

Figure 1-1. Decal Locations (1 of 3)

006431

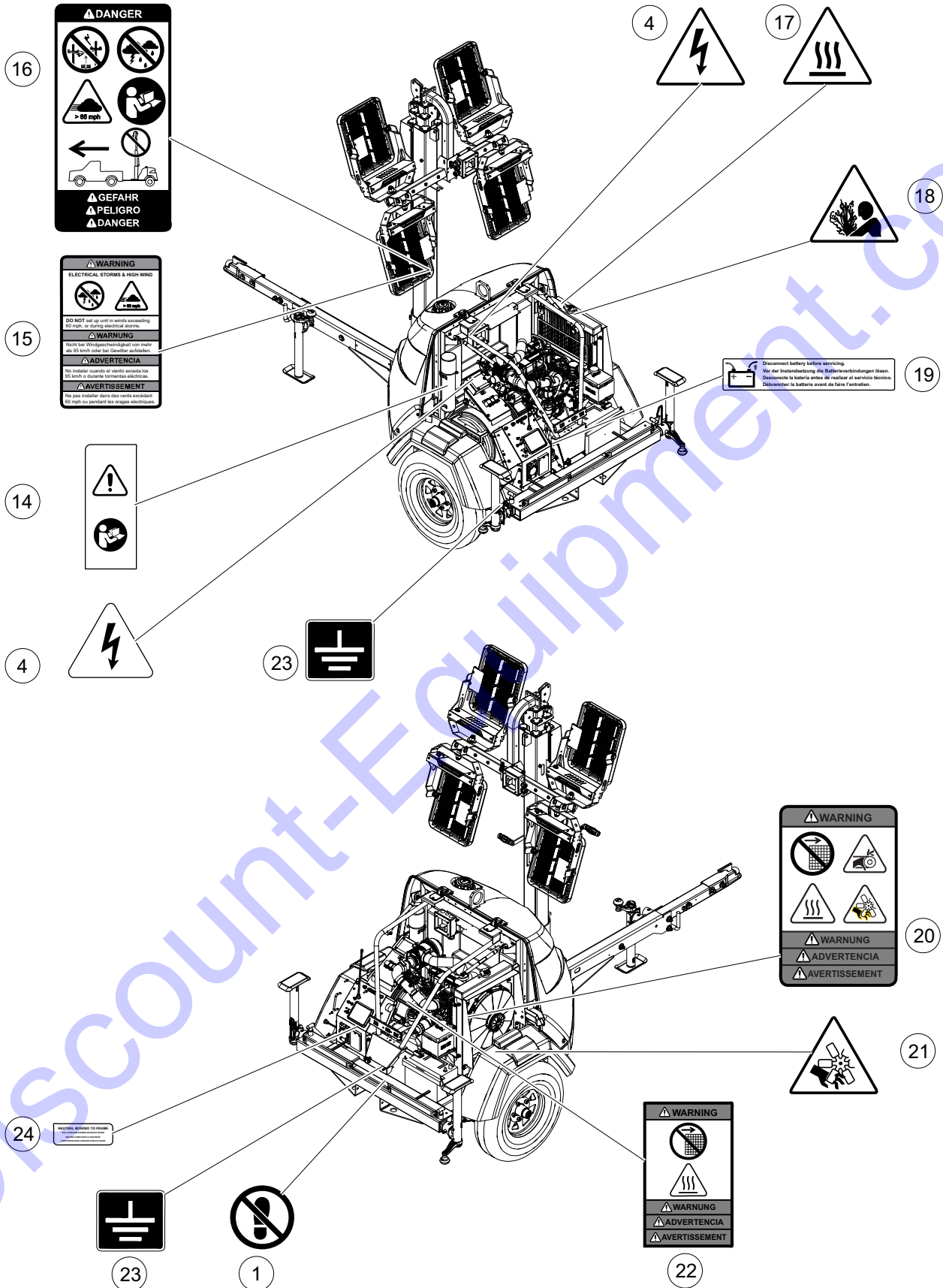

Figure 1-2. Decal Locations (2 of 3)

006432

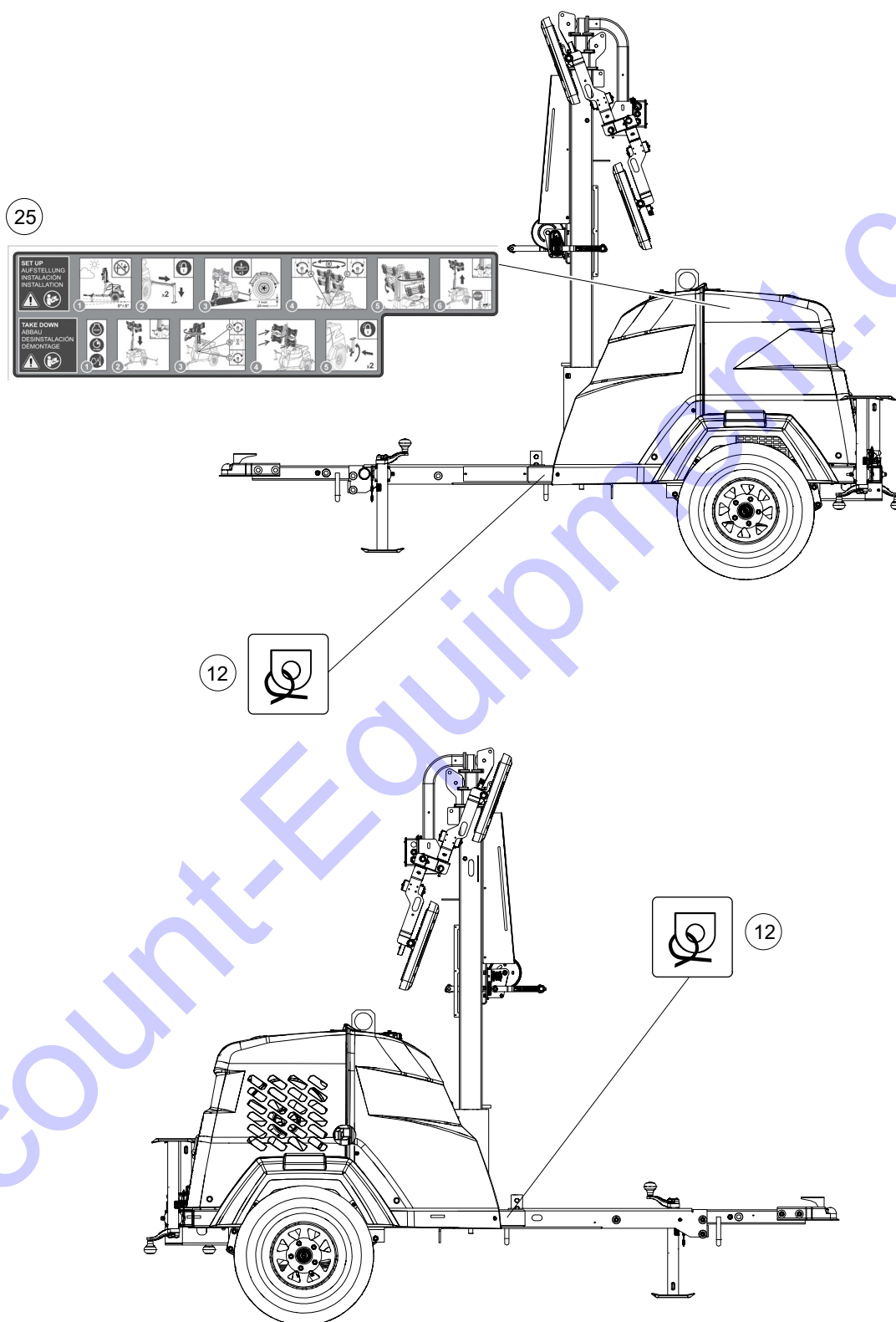

Figure 1-3. Decal Locations (3 of 3)

006433



## Section 2: General Information

### Specifications

DESCRIPTION	UNITS	MLT6SMD
<b>Engine</b>		
Make	—	Mitsubishi®
Model	—	L3E-W464MLD
EPA Tier	—	Tier 4 Final
Horsepower—Prime	hp (kW)	10.5 (7.8)
Horsepower—Standby	hp (kW)	12.2 (9.1)
Operating Speed	rpm	1,350/1,800
Displacement	in <sup>3</sup> (L)	57.97 (0.95)
Cylinders	quantity	3
Fuel Consumption—Full Load	gph (Lph)	0.59 (2.23)
Fuel Consumption—Low Speed (Lights Only)	gph (Lph)	0.19 (0.72)
Battery Type—Group Number	—	24
Battery Voltage	quantity per unit	12 (1)
Battery Rating	cold-cranking amps (CCA)	440
<b>Generator</b>		
Make	—	Marathon®
Model	—	331CSA/B3018
Type, Insulation	—	Brushless, F
<b>Generator Set (Engine/Generator)</b>		
Output - Standby	kW (kVA)	6.0 (6.0)
Output Voltage	volts	120/240, single phase
Output Amperes <b>120V (240V)</b>	amperes	50 (25)
Frequency <b>Hz</b>	Hertz	60
Power Factor	percentage	1 (1Ø)
CSA Listed	—	Yes
<b>Weights</b>		
Dry Weight	lbs (kg)	1332 (604)
Operating Weight	lbs (kg)	1602 (727)
<b>Capacities</b>		
Fuel Tank Volume	gal (L)	40.75 (154.26)
Usable Fuel Volume	gal (L)	39.9 (151.04)
Coolant (including engine)	qt (L)	4.5 (4.3)
Oil (including filter)	qt (L)	5.0 (4.7)
<b>Maximum Run Time</b>		
Operating with LED Lights Only	hours	203
Operating with LED Lights and Export Power	hours	67

DESCRIPTION	UNITS	MLT6SMD
<b>Lighting</b>		
Lighting Type	—	Light-Emitting Diode (LED)
Driver (4)	watts	320
Lumens	lm	172,200
<b>Diffused Lighting (if equipped)</b>		
Lighting Type	—	Light-Emitting Diode (LED)
Driver (4)	watts	320
Lumens	lm	130,960
<b>AC Distribution</b>		
Circuit Breaker Size	amperes	30
Voltage Selection	—	N/A
Voltage Regulation	—	AVR ± 1%
Voltages Available 1Ø	volts	120, 240
Voltages Available 3Ø	volts	N/A
<b>Trailer</b>		
Number of Axles	quantity	1
Capacity—Axle Rating	lbs (kg)	2,200 (998)
Tire Size	in (cm)	13 (33)
Hitch—Standard	—	2 in ball
Maximum Tire Pressure	psi (kPA)	50 (345)
<i>Specifications are subject to change without notice.</i>		

## Unit Serial Number Locations

Refer to the illustration to locate the unit ID tag and Vehicle Identification Number (VIN) tag on the unit. Important information, such as the unit serial number, model number, VIN, and tire loading information are found on these tags. Record the information from these tags so it is available if the tags are lost or damaged. When ordering parts or requesting assistance, you may be asked to provide this information.

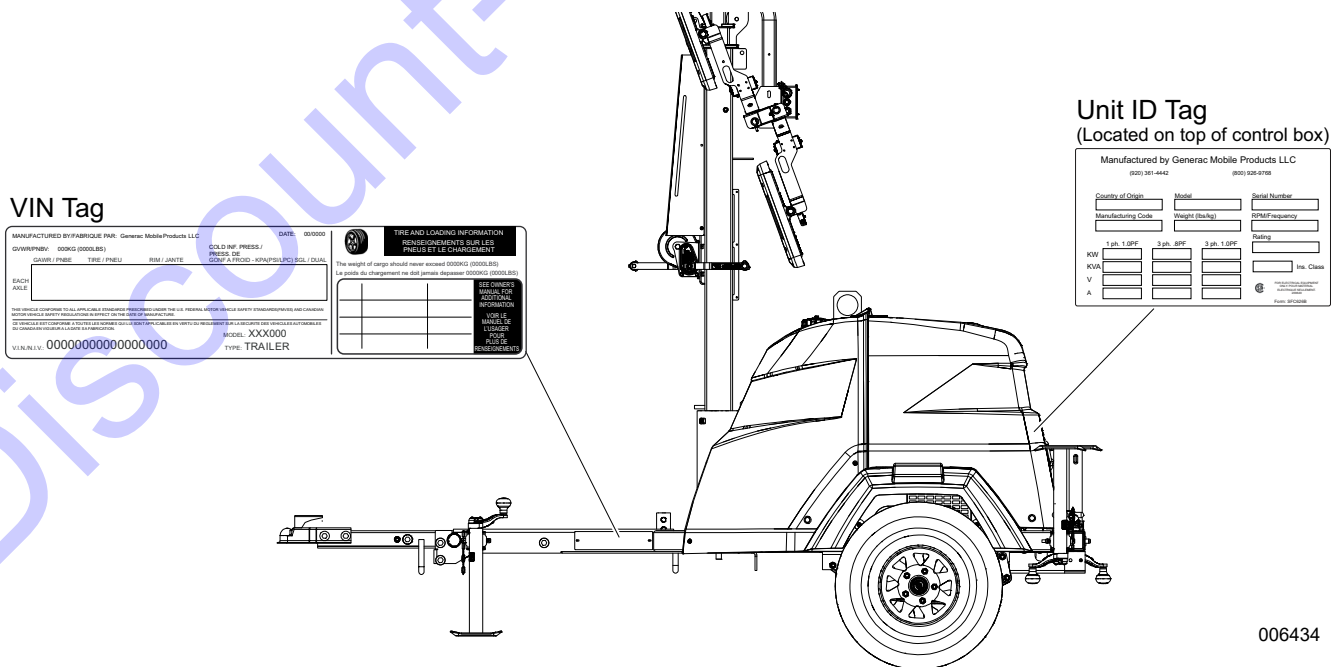

Figure 2-1. Serial Number Locations

## Trailer Tongue Storage and Tow Positions

The trailer tongue is designed to fold upright for shipping and storage.

**IMPORTANT NOTE:** Do not attempt to tow the unit with trailer tongue in the storage position.

### Place Trailer Tongue in Tow Position

1. Verify unit is on a level surface and wheels are blocked.

**NOTE:** See [Figure 2-2](#). Unit ships from factory with jack in the storage location (A).

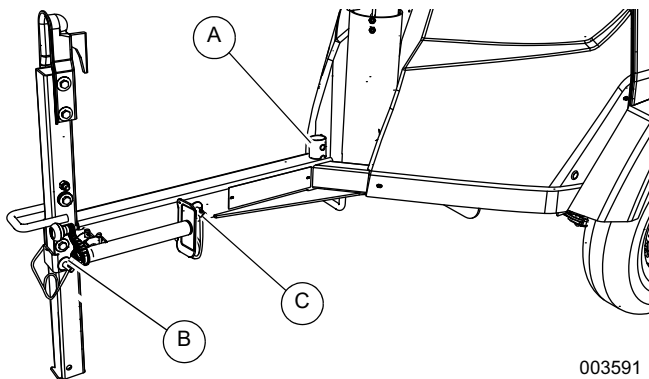

003591

**Figure 2-2. Jack and Pin Locations**

2. Remove clevis securing jack parallel to ground.
3. Remove jack from tongue weldment. Hold jack vertically and extend until weldment on jack is aligned with tongue weldment.
4. See [Figure 2-3](#). Install jack and secure with clevis (D).

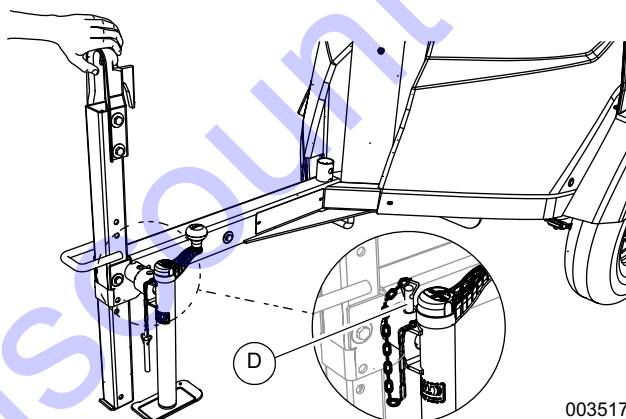

003517

**Figure 2-3. Jack Installed**

5. See [Figure 2-2](#). Remove pins (B) and (C).



**CAUTION**

Pinching and crushing hazard. To avoid possible injury, keep fingers away from pivot point when folding or unfolding trailer tongue.

(000313)

6. See [Figure 2-4](#). Using both hands, slowly lower trailer tongue into tow position.

**NOTE:** Varying levels of effort may be required depending on terrain.

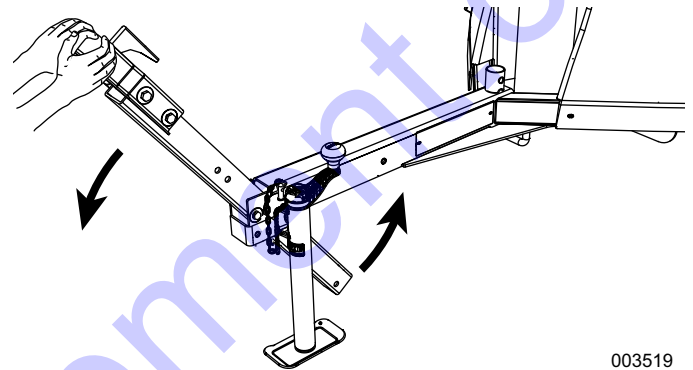

003519

**Figure 2-4. Lower Trailer Tongue into Tow Position**

7. See [Figure 2-5](#). Install pins as shown to secure trailer tongue in tow position.

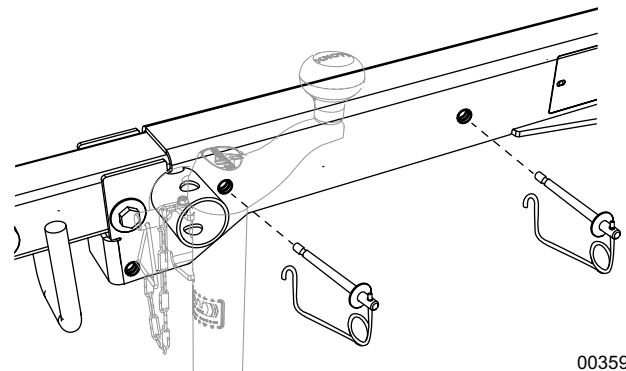

003592

**Figure 2-5. Install and Secure Pins**

### Place Trailer Tongue in Storage Position

1. Verify unit is on a level surface and wheels are blocked.
2. See **Figure 2-6**. Extend jack (A) enough to allow minimum effort to pivot trailer tongue into storage position.

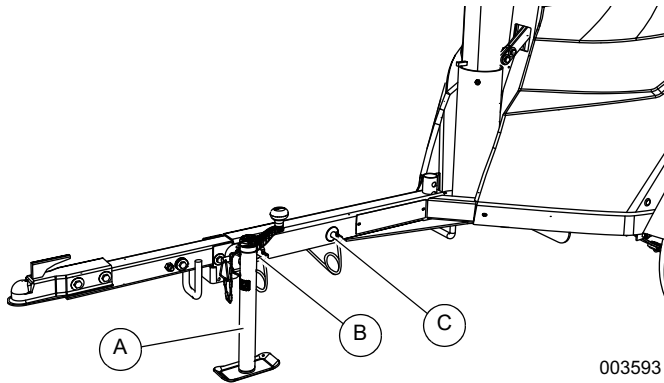

**Figure 2-6. Extend Jack and Remove Pins**

3. Remove pins (B) and (C) from trailer tongue.



**CAUTION**

Pinching and crushing hazard. To avoid possible injury, keep fingers away from pivot point when folding or unfolding trailer tongue.

(000313)

4. See **Figure 2-7**. Pivot trailer tongue into storage position.

**NOTE:** Varying levels of effort may be required depending on terrain.

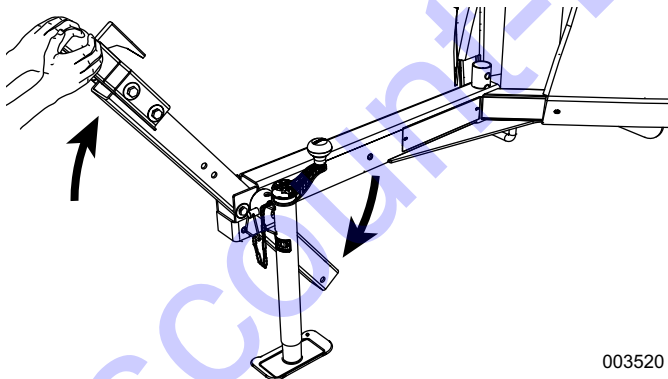

**Figure 2-7. Pivot Trailer Tongue Into Storage Position**

5. See **Figure 2-8**. Install pins (B) and (C) at locations shown to secure trailer tongue in storage position.

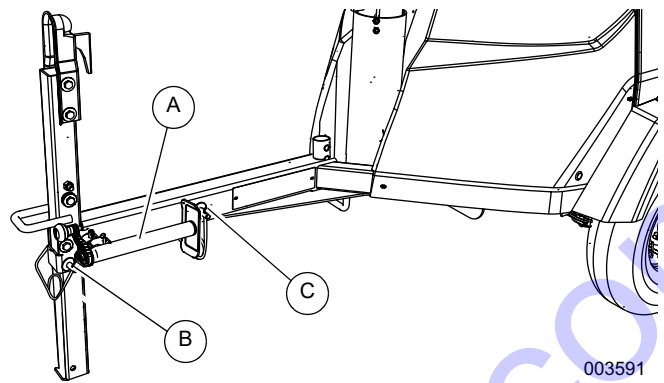

**Figure 2-8. Install Pins and Rotate Jack**

6. Remove clevis and remove jack (A) from tongue weldment.
7. Completely retract jack.
8. Rotate jack 90° counterclockwise, place jack on tongue weldment, and install clevis to secure jack parallel to ground.

## Unit Dimensions

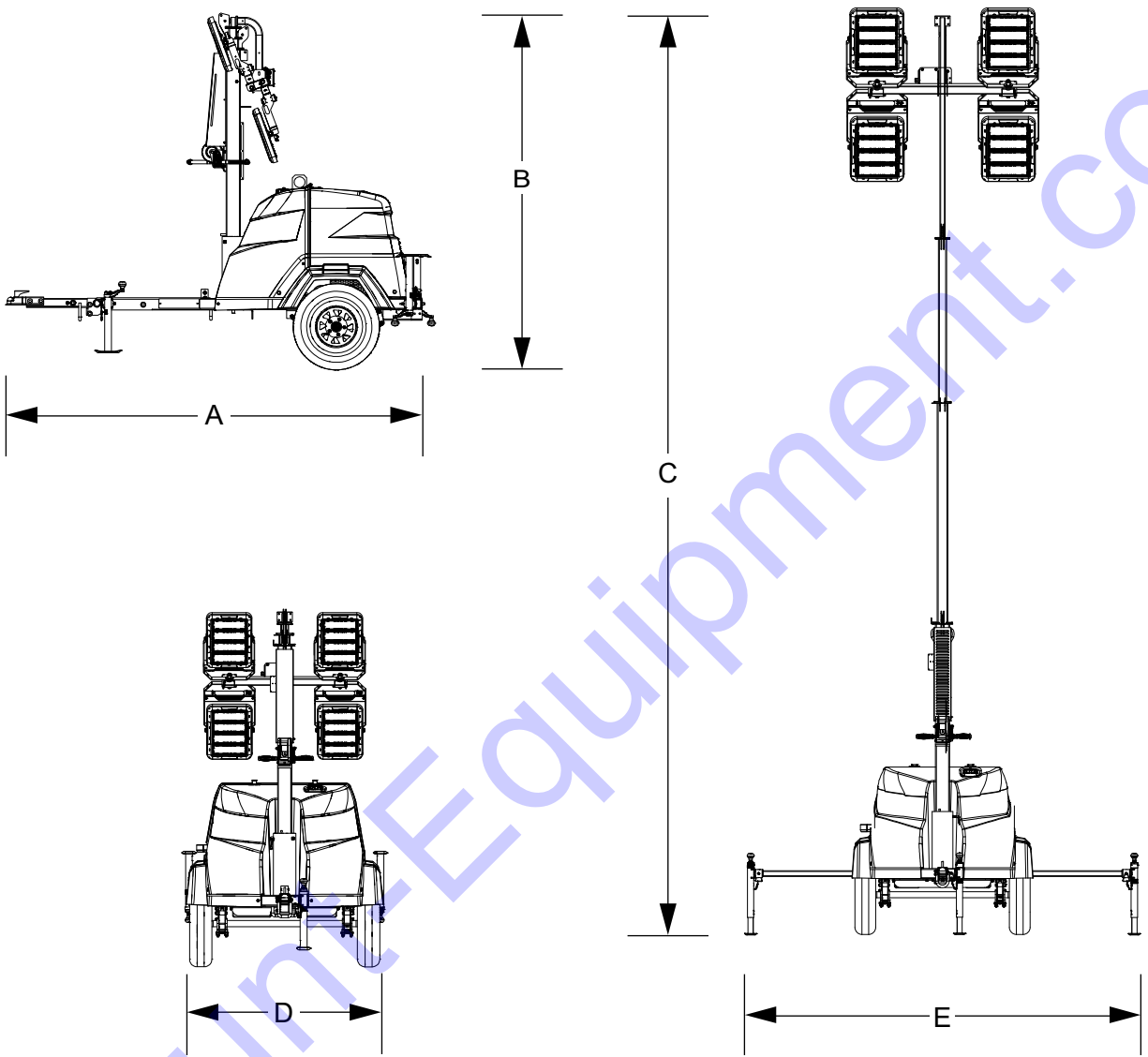

006435

**Figure 2-9. Unit Dimensions**

	A	B	C	D	E
<b>MLT6SMD</b>	118 in (3 m)	101 in (2.6 m)	23 ft (7 m)	57 in (1.5 m)	120.5 in (3.1 m)

*Specifications are subject to change without notice.*

## Component Locations

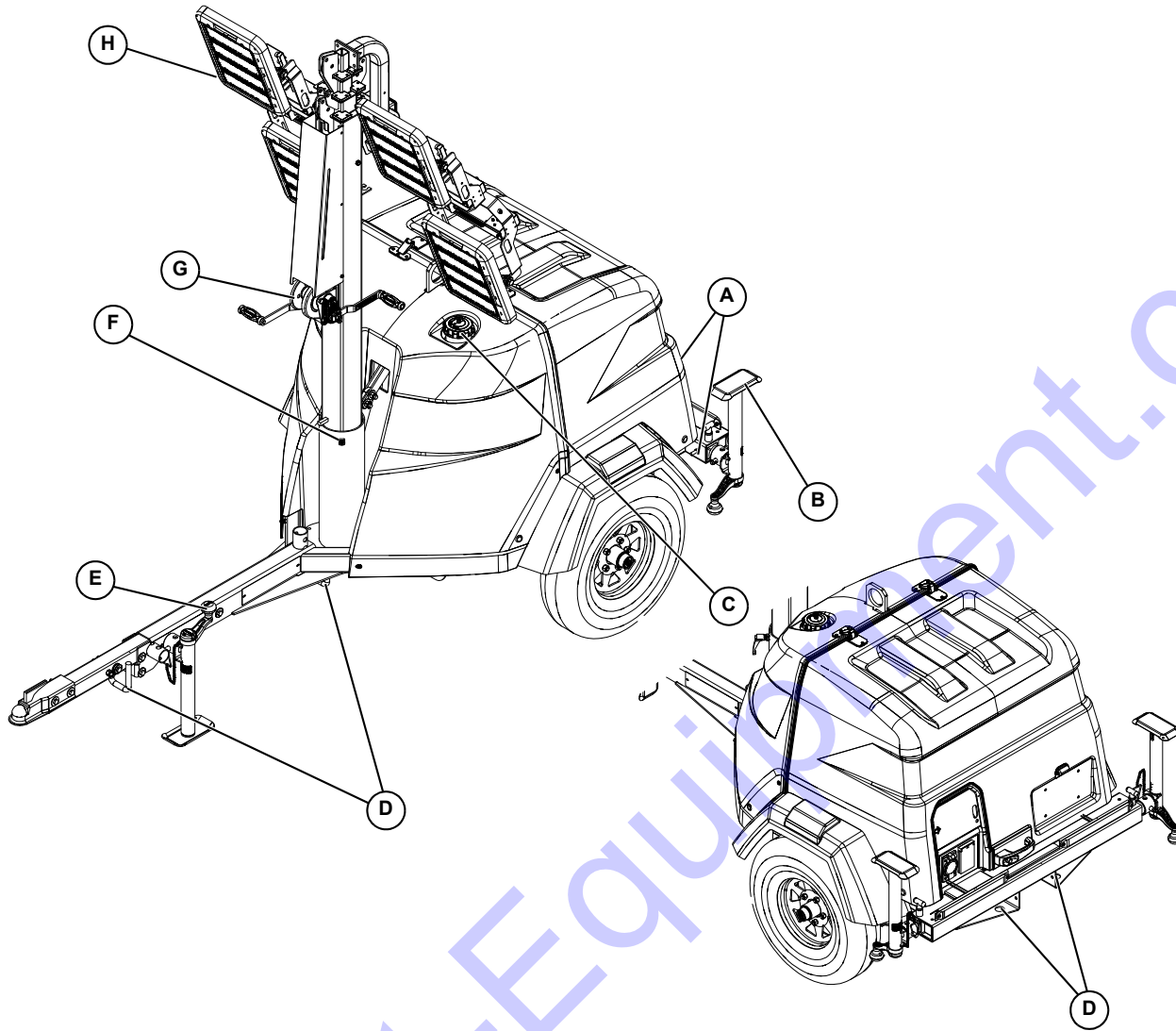

006436

**Figure 2-10. Component Locations—Front and Left Side**

- |   |                    |   |                    |
|---|--------------------|---|--------------------|
| A | Grounding studs    | E | Tongue jack        |
| B | Outrigger and jack | F | Mast rotation knob |
| C | Fuel fill          | G | Winch              |
| D | Tie-down location  | H | Light              |

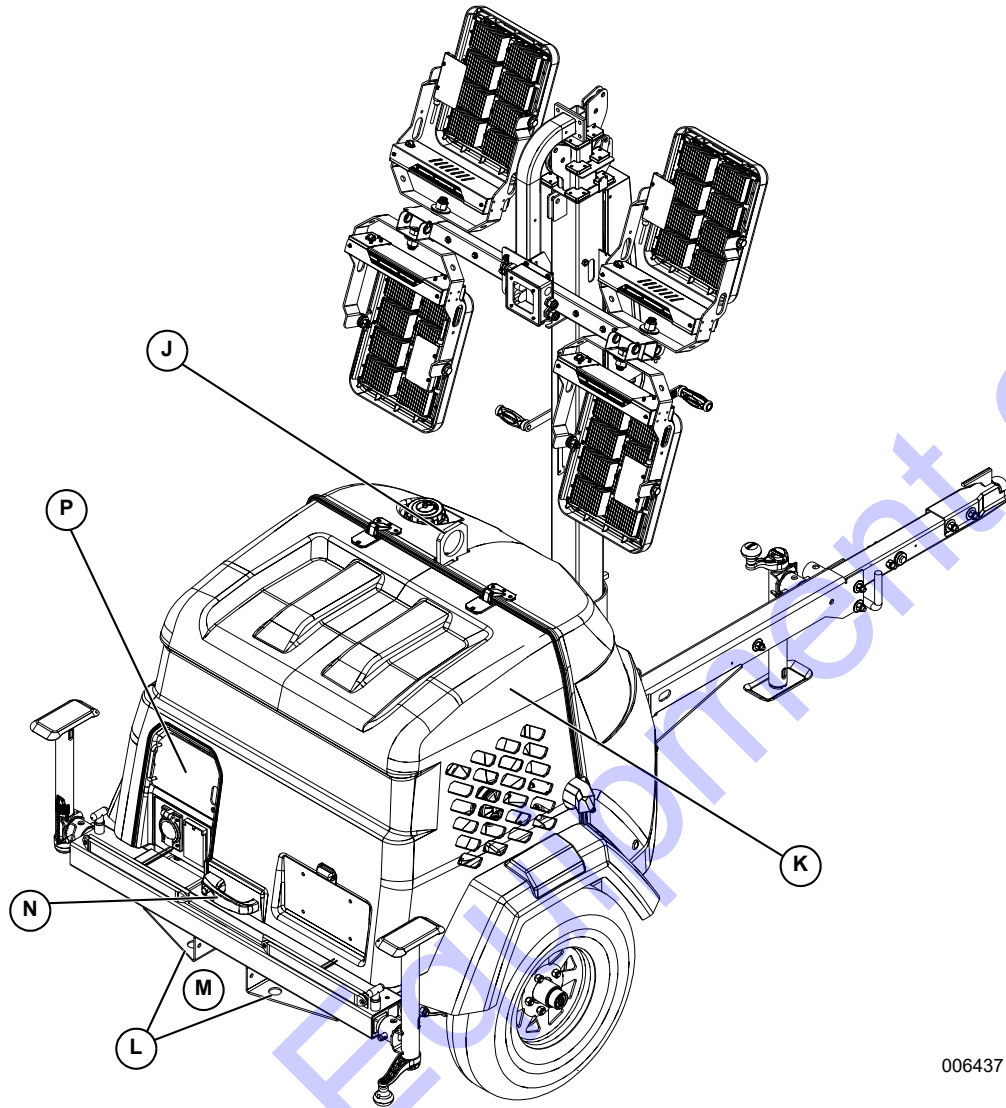

006437

**Figure 2-11. Component Locations—Rear and Right Side**

- |   |                             |   |                                       |
|---|-----------------------------|---|---------------------------------------|
| J | Central lift point          | M | Tandem tow mount (optional—not shown) |
| K | Engine/radiator access hood | N | Hood latch                            |
| L | Forklift pocket             | P | Control panel                         |

# Control Panel

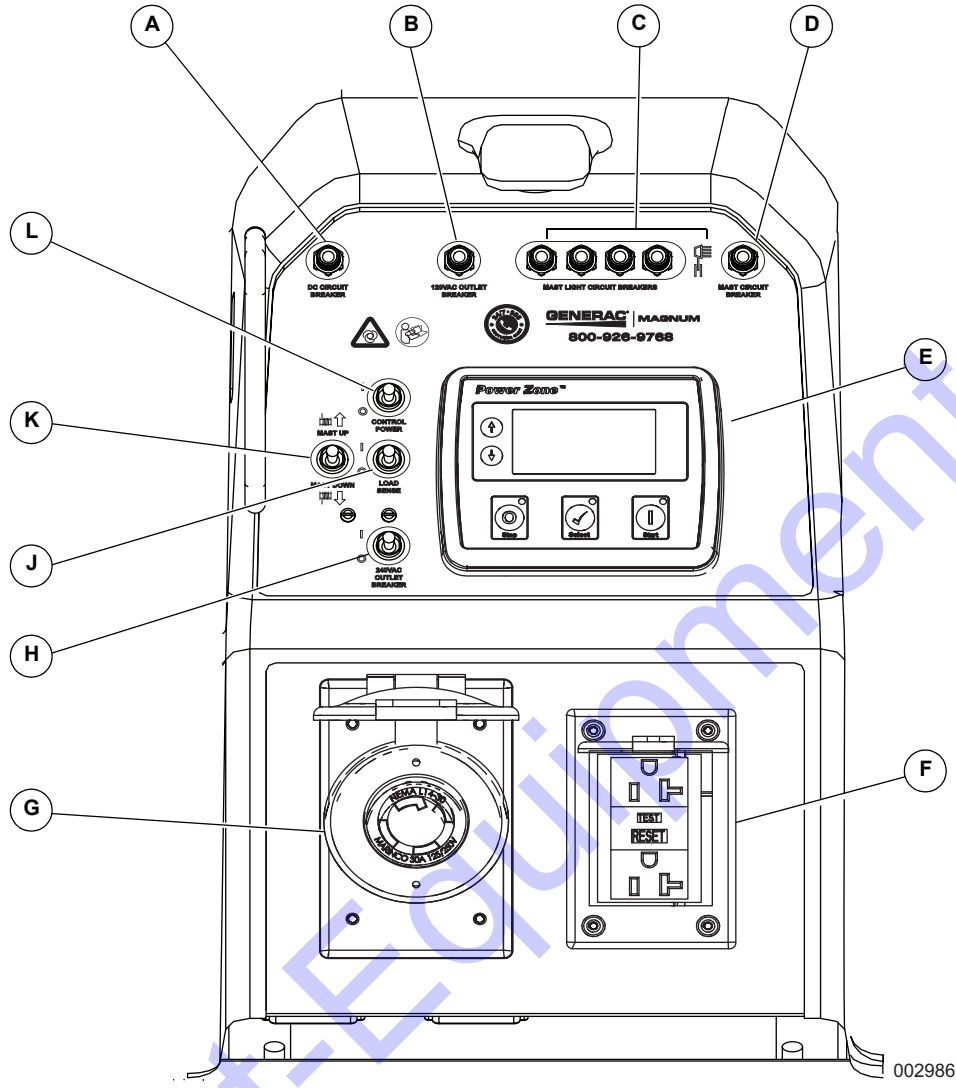

Figure 2-4. Control Panel



## Control Panel Features and Functions

### (A) DC Circuit Breaker

Resets the DC electrical circuit providing power to the control panel and engine components.

### (B) 120VAC outlet breaker

Powers the 120V/20A GFCI outlet.

### (C) Mast light circuit breakers (4)

Individual circuit breakers for the LED drivers and lights.

### (D) Mast circuit breaker

Resets the electrical circuit for the electric winch (if equipped).

### (E) PowerZone®-DLA

Serves as the main control unit for the light tower.

### (F) 120V/20A GFCI receptacle

Customer convenience receptacle for use in connecting auxiliary equipment such as fans, pumps, or drills. Includes a ground fault circuit interrupter (GFCI) test and reset button.

### (G) 240VAC/30A receptacle

Customer convenience receptacle for use in connecting auxiliary equipment such as fans, pumps, or drills.

### (H) 240VAC/30A main breaker

- Enables high speed engine operation for 60 Hz export power.
- Circuit protection for 30A twist lock outlet; circuit feed for 20A outlet breaker.

### (J) Automatic Load Sense switch

Automatic Load Sense works in tandem with the ECOSpeed™ engine to adjust engine operating speed according to lighting and export power requirements. The 240VAC/30A main breaker (H) must be ON to enable Automatic Load Sense.

- **Turning Automatic Load Sense switch ON** enables Automatic Load Sense—the default setting for normal export power operation.
- **Turning Automatic Load Sense switch OFF** disables Automatic Load Sense and allows the engine to run at high speed when the 240VAC/30A main breaker (H) is ON. Use this setting when connecting equipment that requires a higher starting amperage, such as air conditioners, air compressors, or submersible pumps.

### (K) Mast switch (if equipped)

Raises and lowers the mast on units equipped with an electric winch.

### (L) Control power switch

Enables power supply to the PowerZone-DLA.

## ECOSpeed Engine

The unit is equipped with an ECOSpeed engine that runs at variable speeds depending on the applied operational load. Operating temperature remains constant regardless of engine speed or applied loads.

- The engine runs at low speed when the LED lights are operating and the 240VAC/30A main breaker is OFF. Lower speed conserves fuel, reduces emissions and sound output, and extends total run time.
- The engine runs at high speed when the LED lights are turned on and the 240VAC/30A main breaker is ON. Higher speed maximizes export of clean 60 Hz power to the convenience outlets.

Refer to [Operation](#) for more information.

## PowerZone–DLA

The PowerZone–DLA is an auto start controller that monitors the unit and indicates operational status and fault conditions. The controller can be programmed to automatically start or stop based on time schedule, fault condition, or load demand.

The controller constantly monitors vital generator and engine functions for a number of preprogrammed alarm and fault conditions. When a fault condition occurs, the

engine will be shut down automatically and the LCD window will show the fault that caused the shutdown. The fault condition must be corrected to resume operation.

This controller records a history of unit performance, which may be viewed at any time, and will not be lost when the controller is powered down.

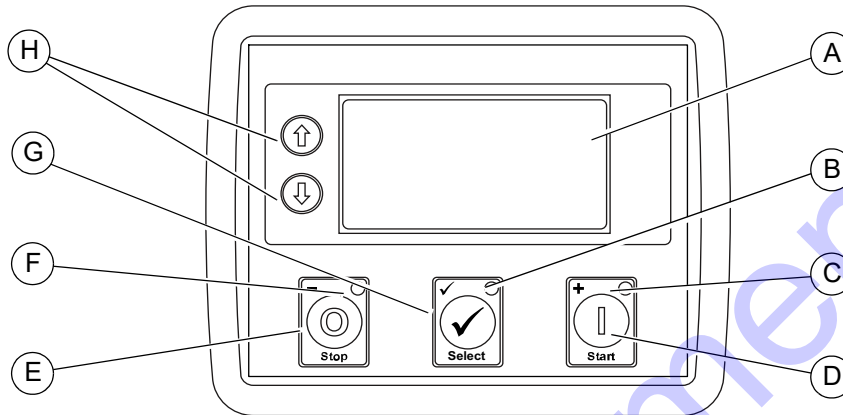

002353

**Figure 2-5. PowerZone–DLA Layout**

### Controller Features and Functions

#### (A) The Liquid Crystal Display (LCD) Window

Displays the various operating screens. The operator can monitor both the engine and generator status while the unit is running by viewing these screens.

#### (B) Select LED

Illuminates when the unit is running in Auto mode.

#### (C) Start LED

Illuminates when the unit is running in Manual mode.

#### (D) Start Button

Starts the engine if there are no shutdown errors and the engine is in “ready to start” status.

#### (E) Stop Button

Shuts down the unit and puts the controller into Stop mode, whether in Manual mode or Auto mode.

**NOTE:** Remove all loads from the generator by opening all circuit breakers (turn to OFF [O]) before pressing the stop button to prevent damage to the generator and connected equipment.

#### (F) Stop LED

Illuminates when the unit is in Stop mode and flashes when an electrical trip and shutdown fault has occurred.

#### (G) Select Button

Confirms entries chosen in the various edit menus and screens.

#### (H) Menu Navigation

Up/down arrows (↑, ↓) used to navigate through the various operator screens. They are also used to raise and lower the mast on units equipped with an electric winch.

### Operator Screens

See [Figure 2-6](#). The operator screens display the most relevant and critical information an operator will need to correctly configure and use the unit. From these six screens, the operator can access information necessary to operate the unit under normal conditions.

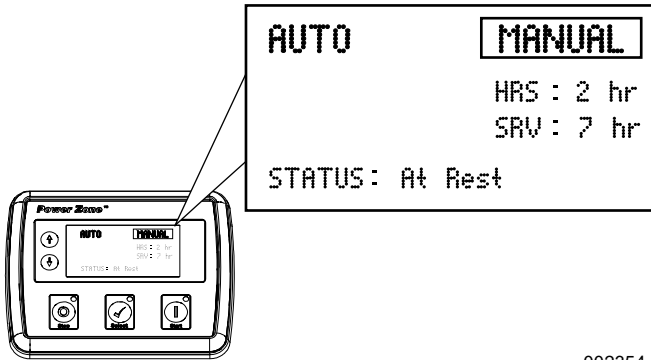

002354

**Figure 2-6. Operator Screens Location**

### Home Screen

See [Figure 2-7](#). Default screen of the controller and displays after the controller is powered up and the unit management software is loaded. Displays the controller mode, total operating hours, hours left until the next service interval, engine operating status, and engine rpm. If the unit is in Auto mode, the Home screen may also display whether the scheduler or “dusk to dawn” are enabled.

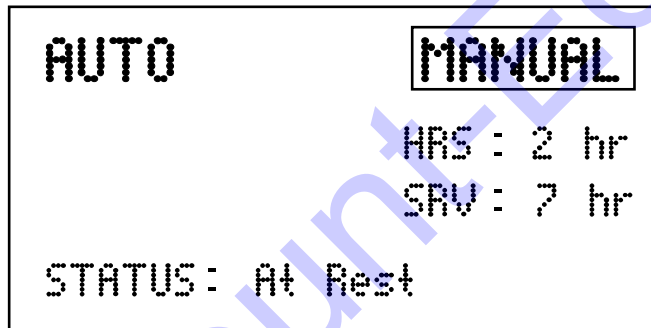

002544

**Figure 2-7. Home Screen**

### Battery Voltage Screen

See [Figure 2-8](#). Displays the engine battery voltage. A normal reading is 13.5–15V on 12 volt systems while running.



002990

**Figure 2-8. Battery Voltage Screen**

### Lights Screen

See [Figure 2-9](#). Enables the operator to turn the lights on and off. Refer to [Light Operation](#) for more information.

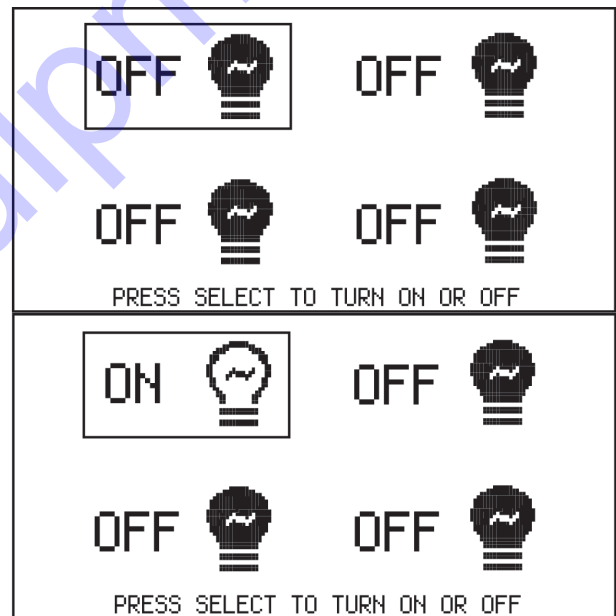

002327

**Figure 2-9. Lights Screen**

**Line Amperage Screen**

See [Figure 2-12](#). Displays the AC output amperage in amps (A). The load balance for each line (L1 and L3) is displayed in both numerical and graphical form. It is important to maintain a balanced load distribution between lines for optimum generator performance.

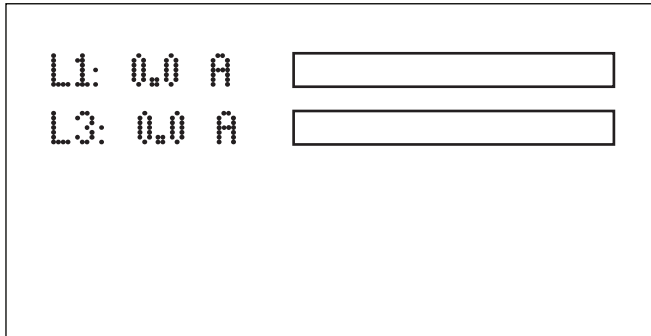

002980

**Figure 2-10. Line Amperage Screen**

**Generator Screen**

See [Figure 2-12](#). Displays the average line voltage, frequency (in Hertz), and power factor for the generator while in operation.

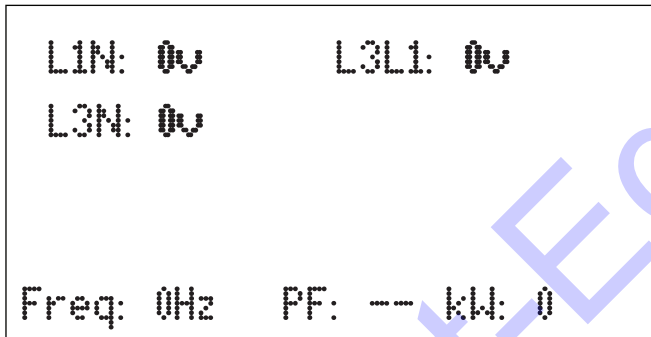

002981

**Figure 2-11. Generator Screen**

**Dusk to Dawn Screen**

**NOTE:** This feature will only work in Auto mode.

See [Figure 2-12](#). Enables or disables the “dusk to dawn” function, which uses a photo sensor to detect the surrounding light level, automatically starting the engine and turning the lights on at dusk. The engine will run and the lights will remain illuminated until dawn.

For instructions on using the Dusk to Dawn feature, see [Dusk to Dawn Sensor](#).



002328

**Figure 2-12. Dusk to Dawn Screen**

**Scheduler Screen**

**NOTE:** This feature will only work in Auto mode.

See [Figure 2-13](#). Enables the operator to program specific times for the lights to turn on and off. Once programmed, the Scheduler will start the engine and illuminate the lights until the designated shutdown time.

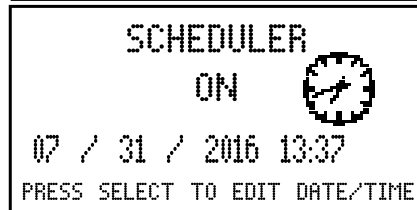

002329

**Figure 2-13. Scheduler Screen**

### Maintenance Screens

See [Figure 2-14](#). The information displayed on the maintenance screens can be used to identify, diagnose, and troubleshoot unit shutdown conditions and poor unit performance.

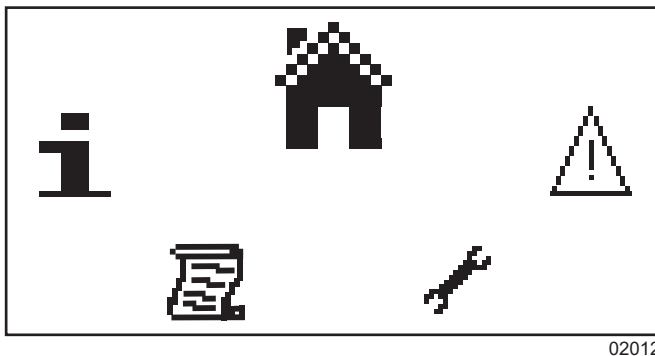

**Figure 2-14. Maintenance Screens**

Icon	Description
	Home screen
	Alarms screen
	Maintenance screen
	Event log screen
	About screen

Proceed as follows to enter the navigation menu:

1. Press the ↑ and ↓ buttons simultaneously.
2. To select the required icon, press the ↑ button to cycle right and the ↓ button to cycle left until the desired operator screen section is reached.
3. Once the desired icon is at the top, press the Select (✓) button to enter that operator screen section.

**NOTE:** Every time the operator screens are entered, the home icon will be located at the top of the screen.

### Home Screen

See [Figure 2-15](#). The Home (🏠) screen is the default screen of the controller and displays after the controller has powered up. The controller automatically returns to Home from any other screen after a period of inactivity.



**Figure 2-15. Home Screen (Manual Mode Shown)**

### Alarms Screen

See [Figure 2-16](#). The Alarms (⚠️) screen displays all the alarms, warnings, and engine Diagnostic Trouble Code (DTC) faults. When an alarm occurs, the controller automatically switches to this screen and remains there until the alarm is cleared. The Stop LED also flashes.

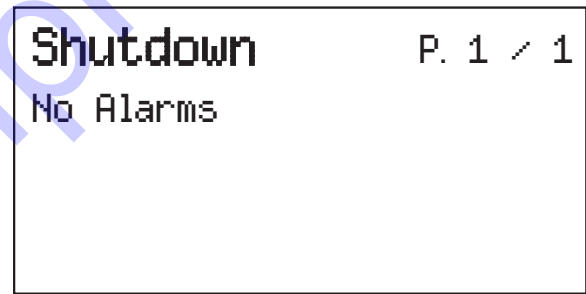

**Figure 2-16. Alarms Screen**

- **Warnings** are non-critical alarm conditions and do not affect the operation of the generator system. They serve to draw the operator's attention to an undesirable condition. By default, warning alarms are self-resetting when the fault condition is removed.
- **Electrical trips** stop the generator in a controlled manner. On initiation of the electrical trip condition, the controller de-energizes all the outputs, including the lights, to remove the load from the generator. Once this occurs, the controller starts the cooling timer and allows the engine to cool off-load before shutting down the engine.
- **Shutdown alarms** stop the generator immediately. On initiation of the shutdown condition, the controller de-energizes all the outputs, including the lights, to remove the load from the generator. Once this occurs, the controller shuts the generator set down immediately to prevent further damage.

**DTC faults** are displayed by the controller.

**Table 2-1. Possible DTC Faults**

Fault	DTC Description
Check Engine Fault	A fault not recognized by the controller has been detected. Contact the engine manufacturer for support.
Low Oil Pressure	Engine oil pressure has fallen below its configured low oil pressure alarm level.
Underspeed	Engine speed has fallen below its configured underspeed alarm level.
Overspeed	Engine speed has risen above its configured overspeed alarm level.
Low Fuel Level	Engine's fuel level has fallen below its configured low fuel level alarm.
Battery Under/Over Voltage	Engine's DC supply has fallen below or risen above its configured alarm level.

To view the active alarms, repeatedly press the ↑ and ↓ buttons until the LCD window displays the alarm.

Continue to press the ↑ and ↓ buttons to cycle through the alarms.

To exit the alarm screen, press the ↑ and ↓ buttons simultaneously to enter the navigation menu. Once entered, cycle to the desired operator screen.

The alarm condition must be corrected before a reset will take place. If the alarm condition remains, it is not possible to reset the unit. The exception to this is the Low Oil Pressure alarm and similar 'active from safety on' alarms, as the oil pressure is low with the engine at rest.

To clear alarms that stop the generator, refer to [Resetting the Maintenance Alarms](#).

**NOTE:** The LCD backlight is on if the unit has sufficient voltage while the unit is turned on, unless the unit is cranking. In this case, the backlight is turned off.

If the controller is left in Stop mode for a period of inactivity, the controller enters Power Save mode. To 'wake' the controller, press the Stop (O) button.

**Maintenance Screen**

See [Figure 2-17](#). The Maintenance screen (🔧) displays the maintenance alarms configured into the controller. The three alarms are for servicing the fuel filter, oil filter, and air filter.

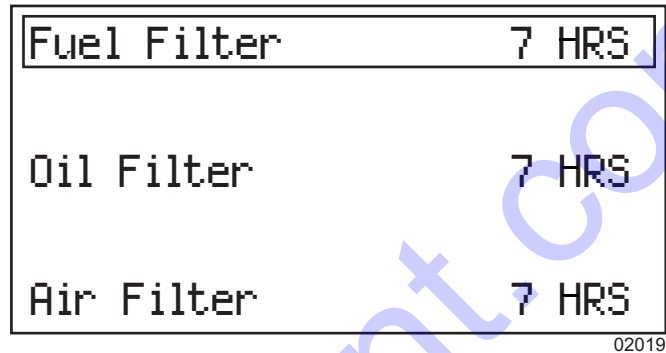

02019

**Figure 2-17. Maintenance Screen**

**Event Log Screen**

See [Figure 2-18](#). The controller's event log (📄) displays a list of the last 15 recorded electrical trips or shutdown events and the engine hours at which they occurred. Once the log is full, any subsequent electrical trip or shutdown alarm overwrites the oldest entry in the log. The log always contains the most recent shutdown alarms.

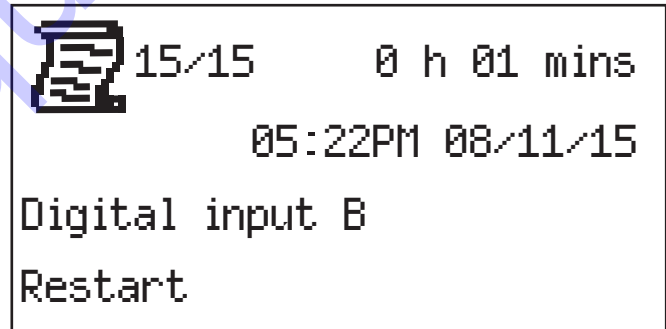

01973

**Figure 2-18. Event Log Screen**

To view the event log:

1. Press the ↑ and ↓ buttons simultaneously to display the navigation menu.
2. Cycle to the event log section and press the Auto button to enter.
3. Repeatedly press the ↑ or ↓ buttons until the LCD window displays the desired event.

Continuing to press down the ↑ or ↓ buttons will cycle through past alarms. Eventually the most recent alarm will display and the cycle begins again.

To exit the event log, press the ↑ and ↓ buttons simultaneously to enter the navigation menu. Once entered, cycle to the desired operator screen.

**About Screen**

See [Figure 2-19](#). The About (  ) screen contains information about the controller such as the controller's date and time, the product and USB identification number, and the application and engine version.

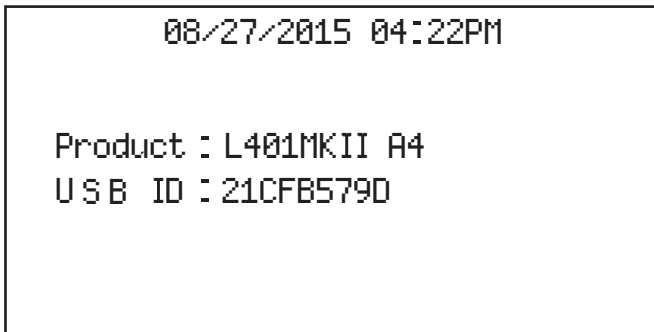

01970

**Figure 2-19. About Screen**

## Section 3: Operation

### Light Tower Setup



#### **⚠ DANGER**

High Voltage. Verify area above unit is clear of overhead wires and obstructions. Contact with high-voltage power lines will result in death or serious injury.

(000260a)

1. For maximum light coverage, position the unit at ground level or in a spot higher than the area being illuminated by the lamps.

**NOTE:** The mast extends up to 23 ft (7 m).

2. See [Figure 3-1](#). Place the unit on firm, flat ground, and block the wheels to prohibit movement. This will make it easier to level the unit.

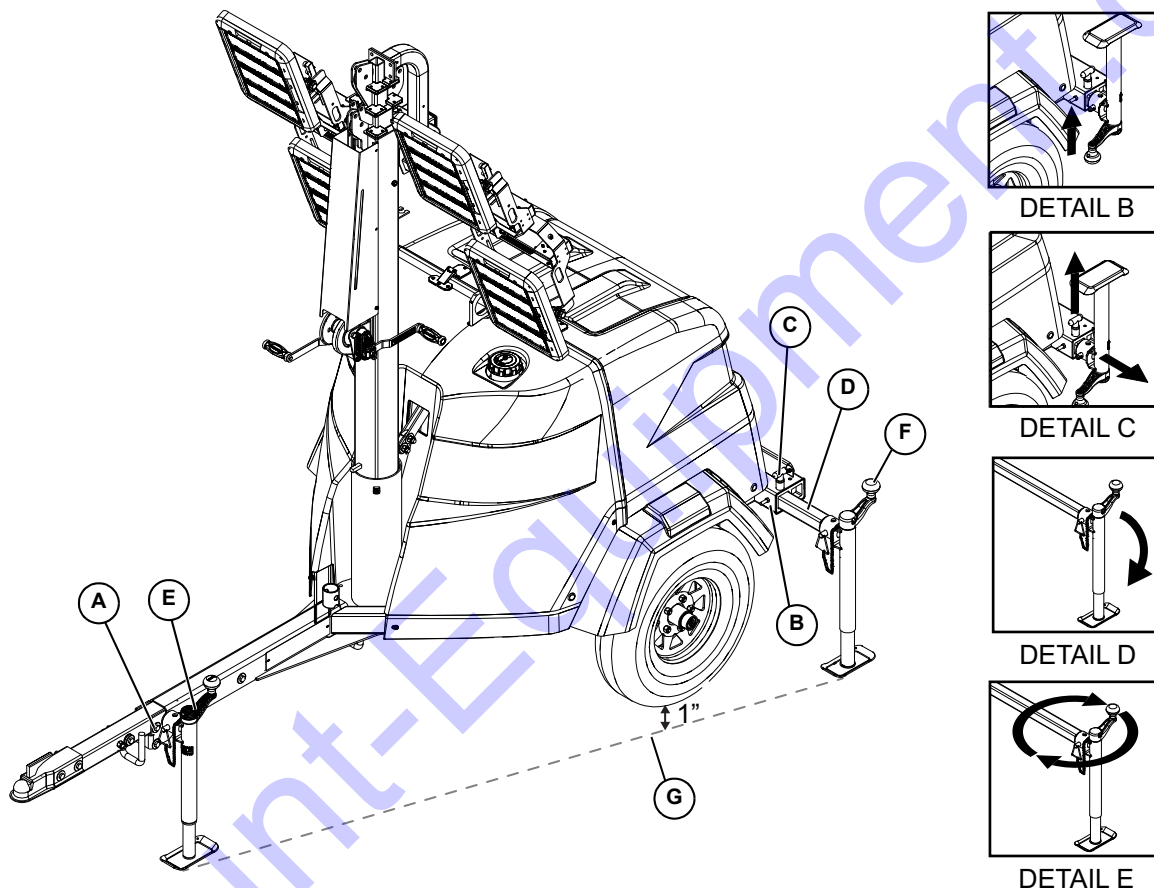

**Figure 3-1. Set Up Outriggers and Jacks**

3. Pull the locking pin (A) on the tongue jack (E) and rotate the jack 90°. Install the locking pin. Rotate the jack handle clockwise to raise the trailer tongue off the towing vehicle.
4. A grounding stud (B) is located on the rear frame of the trailer near the left side outrigger. For grounding requirements, follow local, state, or National Electrical Code (NEC) guidelines.
5. See Details C–D. Pull the locking pins (C) on the outriggers (D) and pull each outrigger out until the spring loaded locking pin snaps back into place. Pull the locking pin on the outrigger jack and rotate each jack 90° so the jack pad is facing down. Install the locking pin.
6. See Detail E. Rotate each jack handle clockwise to start leveling the trailer. Adjust all three jacks by rotating their handles clockwise until they are firmly in contact with the ground. Continue until the wheels are approximately 1 in (2.5 cm) off the ground (F).
7. If applicable, adjust the lamps prior to raising the mast. The lamps may be adjusted up, down, left, or right by simply aiming them in the desired direction.

006470



## Prestart Checklist

All items in the prestart checklist must be completed prior to starting the unit. This checklist applies to both manual and remote starting of the unit.



### ⚠️ WARNING

Consult Manual. Read and understand manual completely before using product. Failure to completely understand manual and product could result in death or serious injury. (000100a)

- Verify all maintenance procedures are up to date. For more information, refer to **General Maintenance** and **Basic Maintenance Schedule**.
- The unit must be level.
- The unit must be dry. Inspect for water inside or near the unit; dry if needed.
- For grounding requirements, follow any local, state, or National Electrical Code (NEC) guidelines.
- Verify the control power switch is OFF (O).
- Verify all circuit breakers are OFF (O).
- Inspect all electrical cords; repair or replace any that are cut, worn, or bare.
- Verify all winch cables are in good condition and centered on each pulley. Do not use if cables are kinked or beginning to unravel.
- Check oil, coolant, and fuel levels. For more information, refer to **General Maintenance**.
- Verify battery connections are secure.
- Turn the battery disconnect switch on, if equipped.
- Inspect the engine fan belt tension and condition.
- Inspect the engine fan belt guard.
- Inspect the engine exhaust system for loose or rusted components.
- Verify all covers are in place and secure.

## Raising the Mast—Manual Winch



### ⚠️ DANGER

Electrocution. DO NOT use the unit if electrical cord is cut or worn through. Doing so will result in death or serious injury.

(000263a)

### ⚠️ WARNING

Tipping hazard. Extend the outriggers and level the unit before raising the mast. Keep the outriggers extended while the mast is up. Failure to do so could cause the unit to tip and fall and could result in death or serious injury.

(000266)

1. Set up and level the unit. See **Light Tower Setup**.
2. See **Figure 3-2**. Inspect the mast cables for excessive wear or damage. Verify the cables are properly centered in each pulley (A). Inspect the electrical cord for damage.

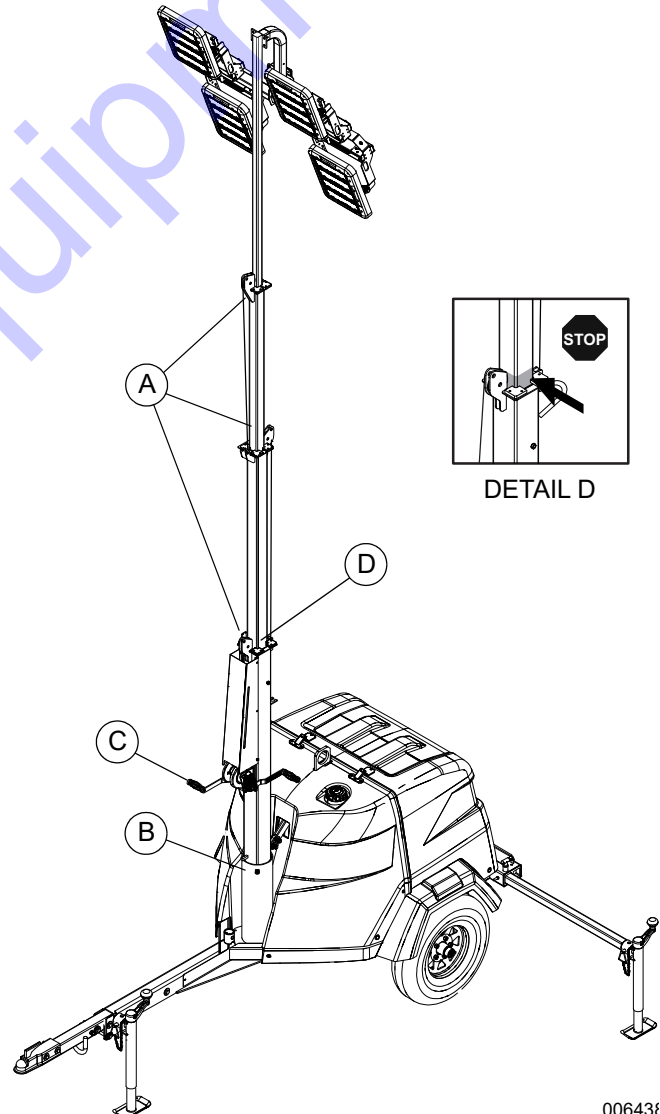

Figure 3-2. Pulley Locations - Manual Winch

00643f

3. Rotate the mast by loosening the mast rotation knob (B) at the bottom of the mast. Turn the mast until the lights face in the desired direction, and then tighten the mast rotation knob to secure the mast in position.
4. Use the winch (C) to slowly extend the mast. Verify the coiled electrical cord is extending at the top sections of the mast. STOP extending the mast when the colored mark (D) on the second mast section is visible as seen in Detail D.

**WARNING**

Tipping hazard. Do not extend the mast beyond the colored mark on the second mast section. The unit can become unstable and tip or fall, causing injury.

(000262)

**WARNING**

Personal Injury. Stop immediately if the mast hangs up or the winch cable develops slack. Excess slack could cause the mast to collapse, resulting in personal injury or equipment damage.

(000265)

**IMPORTANT NOTE:** Contact a GMP ASD immediately if the mast hangs up or the winch cable develops slack.

### Raising the Mast—Electric Winch (If Equipped)



**DANGER**

Electrocution. DO NOT use the unit if electrical cord is cut or worn through. Doing so will result in death or serious injury.

(000263a)

**WARNING**

Tipping hazard. Extend the outriggers and level the unit before raising the mast. Keep the outriggers extended while the mast is up. Failure to do so could cause the unit to tip and fall and could result in death or serious injury.

(000266)

**NOTE:** The control power must be on for the electric winch to function.

1. Set up and level the unit. See [Light Tower Setup](#).
2. See [Figure 3-3](#). Inspect the mast cables for excessive wear or damage. Verify the cables are properly centered in each pulley (A). Inspect the electrical cord for damage.

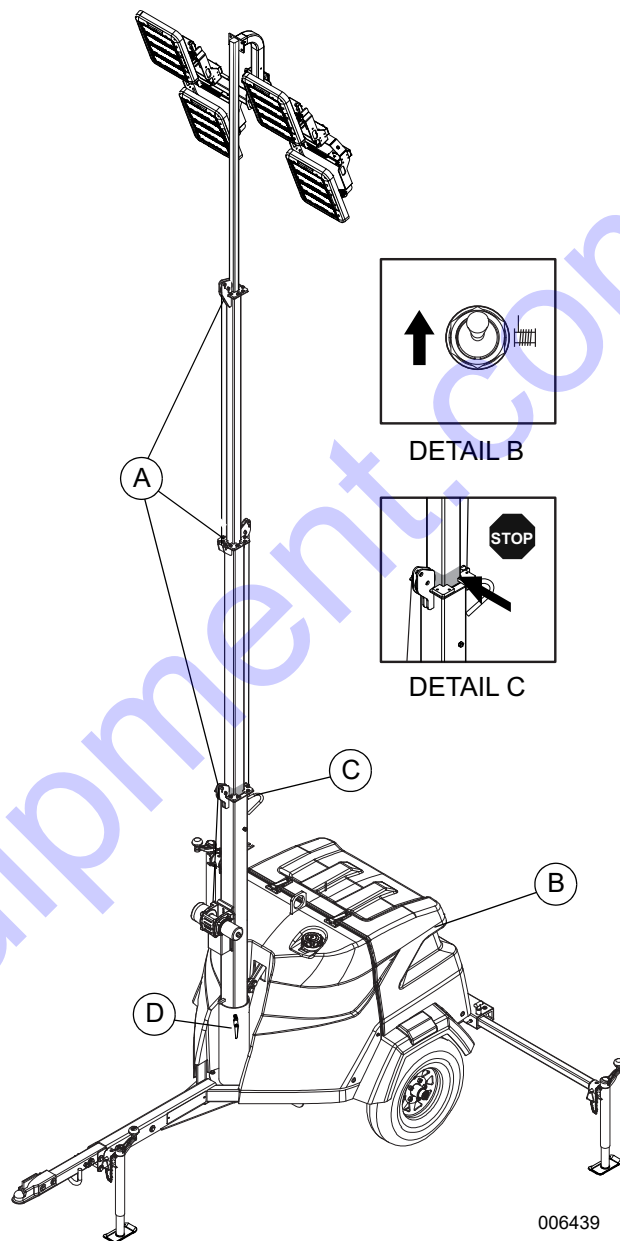

**Figure 3-3. Switch & Pulley Locations - Electric Winch**

3. Rotate the mast by loosening the mast rotation knob at the bottom of the mast (D). Turn the mast until the lights face in the desired direction and then tighten the mast rotation knob to secure the mast in position.
4. Press and hold the winch control switch (Detail B) upward to telescope the mast to the desired height. Verify that the coiled electrical cord is extending at the top sections of the mast. STOP extending the mast when the colored mark (C) on the second mast section is visible as seen in Detail C.

**IMPORTANT NOTE:** A limit switch on the main mast section will disconnect power to the upper electric winch to prevent overextending the mast.

**WARNING**

Tipping hazard. Do not extend the mast beyond the colored mark on the second mast section. The unit can become unstable and tip or fall, causing injury.

(000262)

**WARNING**

Personal Injury. Stop immediately if the mast hangs up or the winch cable develops slack. Excess slack could cause the mast to collapse, resulting in personal injury or equipment damage.

(000265)

**IMPORTANT NOTE:** Contact a GMP ASD immediately if the mast hangs up or the winch cable develops slack.

## Preparing for Start-Up

**NOTE:** If the engine was run out of fuel or the fuel tank was drained, it may be necessary to purge the fuel lines before starting. Refer to the engine manual supplied with the unit.

### Select Auto Mode or Manual Mode

See [Figure 3-4](#). Use the select button to select either Auto or Manual mode.

- Auto mode is required for programming automatic start and stop times (see [Scheduler Screen](#)), or enabling the “Night Watchman” sensor (see [Dusk to Dawn Screen](#).)
- Manual mode is used for on-demand control of the lights and convenience receptacles.

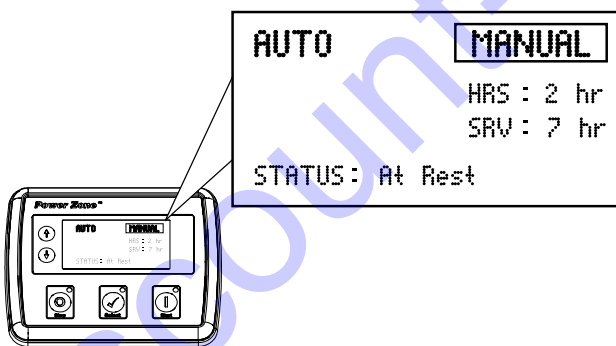

0002354

**Figure 3-4. Selecting Manual or Auto Mode**

### Configure for Intended Use

See [ECOSpeed Engine](#) to determine intended use of the unit.

### LED Lights Only

Turn the 240VAC/30A main breaker to OFF. The engine will run at low speed while operating, greatly reducing sound emissions and fuel consumption.

### LED Lights and Export Power

Turn the 240VAC/30A main breaker to ON and Load Sense OFF. The engine will run at high speed for powering high amperage equipment.

### LED Lights and Export Power with Load Sense

Turn the 240VAC/30A main breaker to ON and Load Sense ON. The engine will run at high speed when detecting applied load(s) such as hand tools and low amperage equipment.

[Table 3-1](#) illustrates the four possible combinations of 240VAC/30A main breaker and load sense switch positions.

**Table 3-1. Engine Speed Selection**

		Load Sense Switch	
		ON	OFF
240VAC/ 30A Main Breaker	ON	Load dependent—variable speed*	High speed
	OFF	Low speed	Low speed
*Engine will speed up automatically when more power is drawn from receptacles.			

## Manually Starting the Unit

Stop mode is the default start-up setting for all units equipped with the Power Zone–DLA. Proceed as follows to start the generator in Manual mode.

1. Verify the 240VAC/30A main breaker is OFF (O).
2. Set the control power switch to ON (I).
3. Verify the Load Sense switch is OFF.
4. When the controller powers up, the Home screen displays on the LCD screen and the Stop LED illuminates to indicate that the controller is in Stop mode. Press the start button to initiate the startup procedure. If there are no existing engine faults, the engine will start and the Start LED will illuminate.

**NOTE:** The engine can be started from any screen. It may take a few seconds for the engine to run smoothly and reach its governed operating speed.

5. If the engine does not start after the first cranking attempt, the engine will pause for 15 seconds to allow the starter to cool. The controller backlight will go out. The engine will make two more attempts to start for a total of three crank cycles.
6. If the engine does not start and run within three starting cycles, the LCD screen will display the “Fail to Start” alarm. The starting sequence can be repeated after the starter cools for at least two minutes. Pressing the Stop (O) button will clear the alarm and reset the controller.
7. Once the engine starts, engine speed increases to 1,800 rpm. The engine may hunt or change speeds until operating speed is reached. After a few minutes at operating speed, the Home screen displays the mode of the unit, the engine status, the engine rpm, and any active program (Scheduler or Dawn to Dusk) in Auto mode.
8. Inspect the generator for excessive noise or vibration and any leaking coolant, oil, or fuel before applying loads.
9. Once the engine is running, allow it to reach normal operating temperature before turning on the outlet breaker.
10. Switch the export outlet breaker to ON (I). Add any loads attached to the outlets. Engine sound will change when a load is applied to the unit.

## Light Operation

See [Figure 3-5](#). The lights are turned on and off using the Power Zone–DLA. To view the light screen, press the ↑ button three times from the Home screen.

**NOTE:** The lights can only be turned on and off while the unit is running in Manual mode. They operate automatically in Auto mode.

1. Switch the main circuit breaker to ON (I) when the engine is up to temperature and running smoothly.
2. To turn the light(s) on, press the Select (✓) button. To turn the light(s) off, press the Select (✓) button.

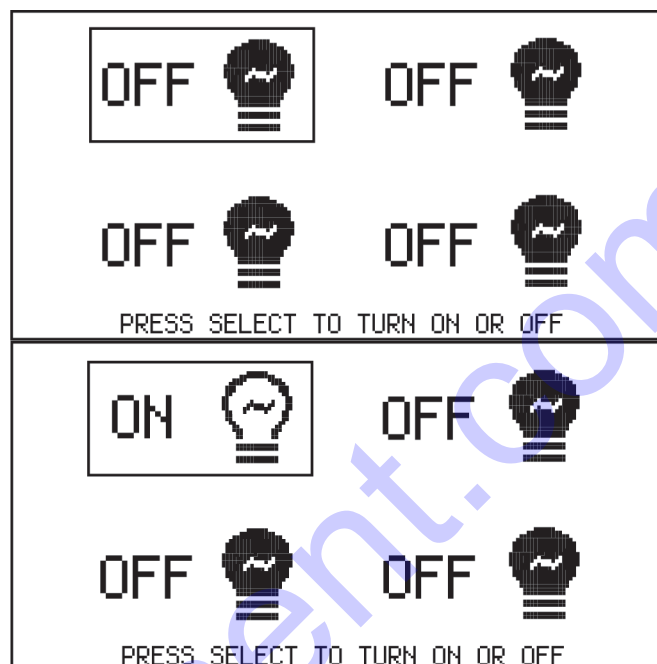

002383

**Figure 3-5. Lights Screen**

**NOTE:** The ECOSpeed engine will automatically run at low speed when the lights and load sense switch are turned on. Engine speed will remain at 1,800 rpm if auxiliary equipment is connected to the 120VAC or 240VAC customer outlets.

## Engine Derating

All units are subject to derating for altitude and temperature. Derating reduces the available power for operating tools and accessories connected to the outlets. For every increase in 1,000 ft (305 m) of elevation, engine performance for this unit typically drops between 2–4%. Engine performance decreases about 1% for every 10 °F (5.6 °C) increase in ambient air temperature over 72 °F (22 °C).

## Wet Stacking

The ECOSpeed engine in this unit eliminates the adverse effects of “wet stacking” caused by prolonged operation of a cold, lightly-loaded diesel engine. These include:

- fuel dilution
- sooting with heavy, black exhaust
- moisture accumulation

Engine temperature and speed are continuously managed to avoid developing a wet stack condition.

## Dusk to Dawn Sensor

This unit is equipped with a “dusk to dawn” photo sensor to detect the surrounding light level, to automatically start the engine and turn the lights on at dusk. The engine will run and the lights will remain illuminated until dawn.

To prepare the sensor for use, proceed as follows at the time of day desired for the lights to turn on:

1. Move shield to highest point.
2. Turn control power on and set unit to AUTO mode.
3. Turn on Dusk to Dawn in controller.
4. Loosen screws and lower shield until the audible alarm is heard and the controller initiates the starting sequence.
5. Tighten screws on dusk to dawn shield
6. Allow unit to start, and verify lights work.

## Customer Convenience Receptacles

See [Figure 3-6](#). The unit is equipped with convenience receptacles for powering accessories or tools from the generator. Power is supplied to the outlets any time the engine is running and the 240VAC/30A main breaker is switched to ON (I). Each receptacle has an individual circuit breaker, located on the control panel. Refer to [Control Panel](#).

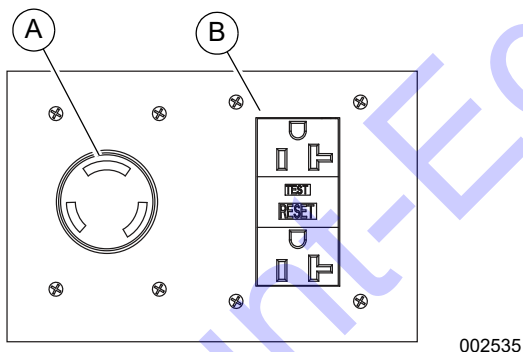

002535

**Figure 3-6. Convenience Receptacles**

See [Figure 3-6](#). The circuit breakers are labeled with the corresponding voltage for the receptacle they protect. The standard control panel is equipped with the following receptacles:

- One 240VAC/30A Twist-lock (A)
- One 120V/20A GFCI (B)

**NOTE:** Do not pull more than a combined total of 4,800W from the receptacles with the lights on. This will overload the generator and cause the main circuit breaker to trip. Should the breaker trip, switch off the lights, remove some of the loads connected to the receptacles.

With all of the lights off, the full generator output may be used with the 240VAC/30A twist-lock receptacle.

## Shutting Down the Unit

**IMPORTANT NOTE:** Verify with personnel using power supplied by the unit and notify them power will be turned off. Verify the power shutdown will not create any hazards by accidentally turning off equipment that needs to remain running (pumps, compressors, lights, etc.).

1. Remove all loads from the receptacles.
2. Switch the lights off using the controller.
3. Set the outlet breaker to OFF (O).
4. Press the Stop (O) button.
5. Set the control power switch to OFF (O) after the unit shuts down.

**NOTE:** Disconnect the battery if the unit is to be stored for an extended period. Refer to the engine operator’s manual for additional extended storage procedures.

## Automatic Shutdown

This unit is equipped with a low oil pressure and high coolant temperature automatic shutdown system. This system will automatically shut off the fuel supply to stop the engine if oil pressure drops too low or the engine exceeds normal operating temperature. Return the control power switch to STOP to reset the unit after the cause of shutdown has been determined.

## Tandem Tow (If Equipped)

See [Figure 3-7](#). The tandem tow hitch option (A) allows the operator to tow a second MLT6 Light Tower in series behind the unit equipped with the hitch.

**IMPORTANT NOTE:** Never tow more than two units at once.

- Connect any trailer wiring to the unit in front (B). Inspect for proper operation of the directional and brake lights.
- Connect the towing chains to the tie down locations (C).
- Avoid sharp turns when towing. **Do not** cross any obstacles more than 12 in (30.5 cm) deep.
- Tandem tow speeds:
  - a. Paved highway—45 mph (72 km/h)
  - b. Graded gravel—25 mph (40 km/h)
  - c. Cross country—10 mph (16 km/h)

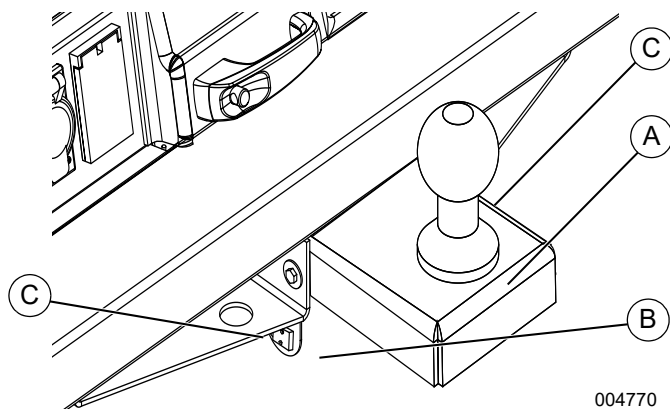

Figure 3-7. Tandem Tow

004770

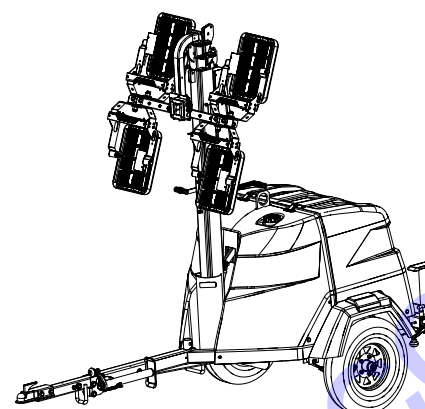

Figure 3-8. Stowed (Travel) Position

003275

## Telemetry (If Equipped)

The digital telemetry option allows the operator to remotely monitor the unit fuel level (depending on the type of telemetry selected, and other optional equipment). A transmitter inside the engine compartment sends real time equipment status information to the user via cellular or satellite connection.

## Spark Arrester (If Equipped)

A spark arrester, installed on the unit exhaust, may be required by code in certain municipalities. Contact the local authority having jurisdiction to determine whether or not a spark arrester must be installed on the unit before operation.

## Lowering the Mast—Manual Winch



Personal Injury. Stop immediately if the mast hangs up or the winch cable develops slack. Excess slack could cause the mast to collapse, resulting in personal injury or equipment damage. (000265)

1. Shut down the lights and engine. See [Shutting Down the Unit](#).
2. Lower the mast.
3. Collapse the mast to its lowest position using the winch handles. Verify the electrical cord does not get caught in, or pinched by, the mast while it is being lowered.

**IMPORTANT NOTE:** Contact a GMP ASD immediately if the mast hangs up or the winch cable develops slack.

4. See [Figure 3-8](#). If the unit is going to be moved, rotate the mast so the lights face the rear of the unit.

To rotate the mast:

- a. Loosen the mast rotation knob.
- b. Rotate the mast until the white arrows are aligned and the metal stop tabs are touching.
- c. Tighten the mast rotation knob.

## Lowering the Mast—Electric Winch (If Equipped)

### Electrically Lowering the Mast



Personal Injury. Stop immediately if the mast hangs up or the winch cable develops slack. Excess slack could cause the mast to collapse, resulting in personal injury or equipment damage. (000265)

**NOTE:** The controller power must be on to lower the mast with the electric winch. If the controller is off, the electric winch will not work.

1. Shut down the lights and engine. See [Shutting Down the Unit](#).
2. Press and hold the winch control switch downward to collapse the mast to the lowest position. Verify the electrical cord does not get caught in, or pinched by, the mast while it is being lowered.
3. If the unit is going to be moved, rotate the mast so the lights face the rear of the unit. To rotate the mast:
  - a. Loosen the mast rotation knob.
  - b. Rotate the mast until the white arrows are aligned and the metal stop tabs are touching.
  - c. Tighten the mast rotation knob.

**IMPORTANT NOTE:** Contact a GMP ASD immediately if the mast hangs up or the winch cable develops slack.

**NOTE:** If the generator is not operational, and the batteries do not have enough power to lower the mast, it may be necessary to lower the mast manually.

### Manually Lowering the Mast

**IMPORTANT NOTE:** Do not use this procedure unless it is absolutely necessary. Frequent use of this procedure could damage the motor shaft.

1. See [Figure 3-9](#). Remove the motor cover (A).

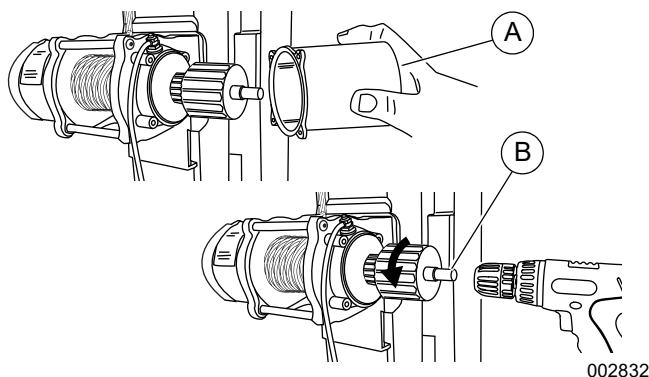

**Figure 3-9. Manually Lowering the Mast**

2. Attach a drill chuck firmly to the exposed motor shaft (B).
3. Using the drill, slowly rotate the motor shaft counterclockwise to lower mast.
4. Detach the drill chuck and install the motor cover after the mast is completely lowered.

## Lower Radiator Hose Heater (If Equipped)

### Use and Maintenance

The lower radiator hose heater is designed to prevent engine coolant from freezing in extreme cold weather conditions. While the heater is designed to be operated overnight if necessary, 2–5 hours of heating just prior to starting is usually sufficient for proper engine starting.

**NOTE:** Use the lower radiator hose heater only in its designated location. Incorrect use can damage the engine.

Proceed as follows when operating a unit equipped with a lower radiator hose heater.

1. Verify the unit is level to maintain correct orientation of the heater while it is in operation.
2. Verify the cooling system is full of the correct mixture of water and engine coolant before each heater use.
3. Use only an undamaged, outdoor rated, three-prong grounded 120VAC extension cord with a

minimum amperage rating of 10A. Connect the cord to a properly grounded 120VAC, GFCI outlet.

4. Before starting the engine, unplug the extension cord from the power first, then unplug the heater cord set from the extension cord.

## Towing the Unit

Once the engine is shut down and the mast and lights are properly stowed, proceed as follows to prepare the unit for towing.

1. Raise the outrigger jacks completely and release the locking pins to rotate them up into the travel position. Verify the locking pins snap into place. Release the outrigger locking pins and slide the outriggers into the trailer frame until the locking pins snap into place.
2. Use the tongue jack to raise or lower the trailer onto the hitch of the towing vehicle. Lock the hitch coupling and attach the safety chains or cables to the vehicle in a criss-cross pattern. Remove the tongue jack locking pin and rotate the jack into the travel position. Replace the locking pin.
3. Lubricate the grease fittings located on the leveling jacks. Refer to [Trailer Wheel Bearings](#). For maintenance interval information, refer to [Basic Maintenance Schedule](#).
4. Connect any trailer wiring to the tow vehicle. Check for proper operation of the directional and brake lights.
5. Verify the enclosure is correctly latched.
6. Inspect for correct inflation of the trailer tires. For maximum tire pressures, refer to [General Information](#).
7. See [Figure 3-10](#). Inspect the wheel lugs. Tighten or replace any lugs that are loose or missing. If a tire has been removed for axle service or replaced, tighten the lugs in the order shown, to the following specifications:

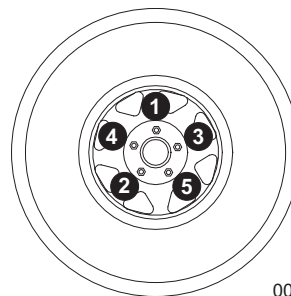

**Figure 3-10. Tightening Wheel Lugs**

- a. Start all lug nuts by hand.
- b. First pass: tighten to 20-25 ft-lbs (27-33 Nm).
- c. Second pass: tighten to 50-60 ft-lbs (67-81 Nm).
- d. Third pass: tighten to 90-120 ft-lbs (122-162 Nm).

**NOTE:** After the first road use, re-torque the lug nuts in sequence.

**NOTE:** Maximum recommended speed for highway towing is 45 mph (72 km/h). Recommended off-road towing speed is not to exceed 10 mph (16 km/h) or less, depending on the terrain.

## Lifting the Unit

Proceed as follows to prepare the unit for lifting:

1. Verify the equipment being used to lift the unit is in good condition and has sufficient capacity. For approximate weights, refer to [Specifications](#).
2. Close and lock all hoods and doors.
3. See [Figure 3-11](#). Stow the mast and lights in the travel position as shown.
4. Always remain aware of people and objects around the unit while preparing, maneuvering, and lifting the unit.
  - Before lifting the unit, attach any slings, chains, or hooks directly to the central lift point (A).

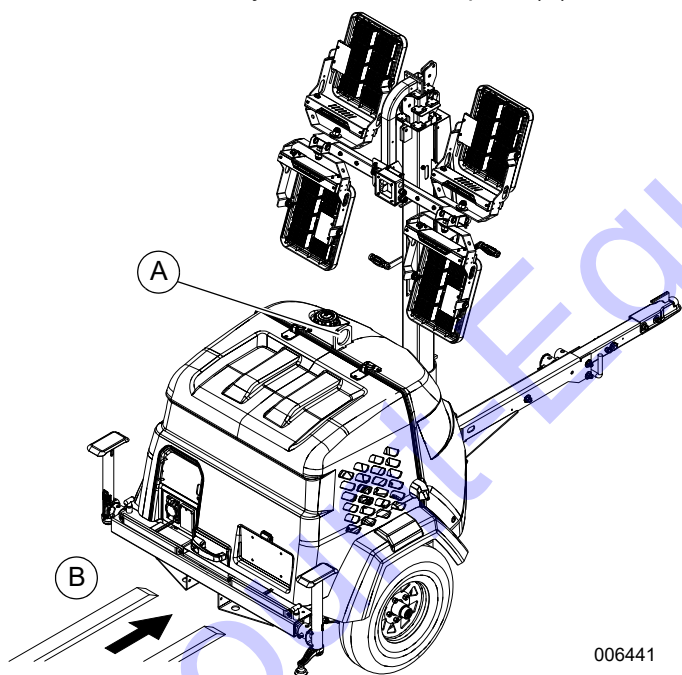

**Figure 3-11. Lifting Points**

- Use the forklift pockets (B) with care. Lift only from the side or the rear. Avoid approaching the unit at an angle, as this can permanently damage the forklift pockets, tires, or cabinet. Verify any obstructions are clear of the forklift tines before lifting.

## Tying Down the Unit

Verify the equipment being used to fasten the unit is in good condition and has sufficient strength to hold the unit in place during transport.

See [Figure 3-12](#). Use the tie-down points (C) as shown.

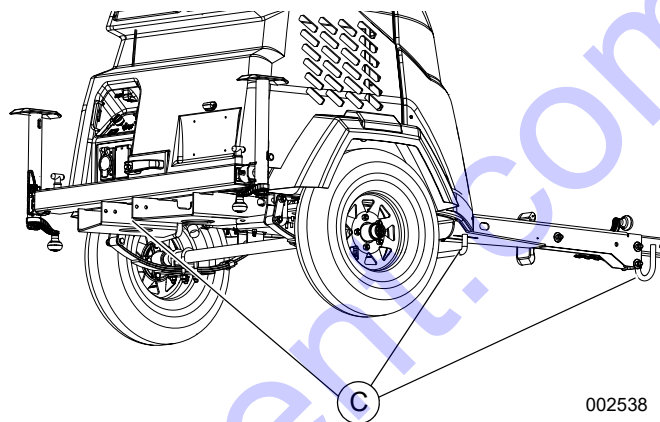

**Figure 3-12. Tie-Down Points**



## Section 4: Maintenance

### Emissions Information

For emissions warranty information, please refer to the diesel engine manual supplied with this unit.

### Daily Walk-Around Inspection



Equipment Damage. Failure to perform a daily inspection could result in damage to the unit.

(000306)

Perform a walk-around inspection of the unit every day before starting the unit. Look for conditions that could hinder performance or safety, such as (but not limited to):

- Oil/coolant/fuel leakage
- Blocked vents
- Loose/missing hardware
- Loose or broken electrical connections

Inspect the fan belt for cracks, fraying, or stretching. Verify the belt is properly seated in the pulley grooves. Replace the belt according to the manufacturer's recommendations.

### General Maintenance

Incorrectly maintained equipment can become a safety hazard. In order for equipment to operate safely and correctly over a long period of time, periodic maintenance and occasional repairs are necessary. **DO NOT** perform routine service (oil and filter changes, cleaning, etc.) unless all electrical components are shut off.

Regular maintenance will improve performance and extend engine/equipment life. Generac Mobile Products, LLC recommends that all maintenance work be performed by a GMP ASD. Regular maintenance, replacement, or repair of the emissions control devices and systems may be performed by any repair shop or person of the owner's choosing. However, to obtain emissions control warranty service free of charge, the work must be performed by a GMP ASD or authorized Mitsubishi® engine dealer depending on the repair. See the emissions warranty.

### Preparing for Service

Before servicing the unit, always follow the instructions listed below.

1. Verify the control power switch is OFF.
2. Verify the circuit breakers are OFF.
3. Disconnect the negative (–) terminal on the battery.

4. Attach a "Do Not Start" sign to the control panel to signify that the unit is being serviced and reduce the chance of unwanted operation.

### Cleaning the Unit



Equipment damage. Never spray water to clean unit. Do not introduce water into generator windings, terminals, or fuel system during the cleaning process. Doing so will result in equipment damage. (000325a)

Always clean the unit after each use to remove dust, grease, mud, or spilled fuel or oil. Use soft, clean rags to wipe the cabinet exterior and control panel. Low-pressure compressed air (less than 40 psi [276 kPa]) can also be used to remove dust and debris from the cabinet interior.

This unit contains sensitive electronic components that can be damaged by high pressure and heat. **Do not:**

- wash the unit with a high pressure hose or power washer.
- wash the engine block or fuel tank with a power washer or steam cleaner. Water may enter the cabinet and collect in the generator windings or other electrical parts, causing damage.

### Inspecting the Unit

- If the unit is stored outside, inspect for water inside the cabinet and generator before each use. If wet, dry the unit thoroughly before starting.
- Inspect condition of electrical cords. **DO NOT** use the unit if insulation is cut or worn through.
- Verify winch cables are in good condition and centered on each pulley. **DO NOT** use a cable that is kinked or starting to unravel.
- Verify the wheel lugs are present and properly tightened. Refer to [Towing Safety](#).
- Inspect the coolant level in the coolant overflow jug located near the radiator. Refer to the engine operator's manual for coolant recommendations and proper mixture. Normal operating level is between the 'full' and 'add' markings on the overflow jug.
- After engine is stopped and completely cool, coolant may be added directly to the coolant overflow jug.

- Check the oil level daily. Refer to the engine operator’s manual for the appropriate oil specification. Verify that the oil is correct for special operating conditions such as a change in season or climate.
  - **DO NOT** start the unit if the engine oil level is below the add mark on the dipstick.
  - Normal operating level is in the cross-hatch pattern between the full and add markings on the dipstick.
- Only add oil if the oil level is below the add mark on the bottom of the cross-hatch pattern on the dipstick. **DO NOT OVERFILL** the crankcase.
- Check the fuel level.
- If the unit is connected to a remote start or transfer switch, verify the remote switch is also off and tagged.

**NOTE:** If the engine was run out of fuel or the fuel tank was drained, it may be necessary to purge the fuel lines. Refer to the engine operator’s manual supplied with the unit.

## Basic Maintenance Schedule

Refer to the diesel engine manufacturer’s operating manual for a complete list of maintenance requirements. Failure to comply with the procedures as described in the engine operator’s manual will nullify the warranty, decrease performance, and cause equipment damage or premature equipment failure. Maintenance records may be required to complete a warranty request.

Use the schedule in the following tables as a guide for regular maintenance intervals. For additional or replacement copies of the engine operator’s manual, contact a GMP ASD.

Item	Daily	750 Hours	1000 Hours	As Required
Perform a <i>Daily Walk-Around Inspection</i>	◆			
Check oil level	◆			
Check coolant level	◆			
Check fuel level	◆			
Check tire pressure	◆			
Inspect all electrical connections	◆			
Inspect radiator fins for debris; clean as required	◆			
Inspect light tower winch for proper operation	◆			
Replace engine oil and oil filter			◆*†	
Belt and belt tension; inspect, adjust, and replace if necessary		◆*	◆*	
Replace fuel filter		◆	◆	
Inspect battery condition		◆	◆	
Replace air cleaner element		◆	◆	
Lubricate leveling jacks				◆
Fuel system—purge air				◆
Drain residual water from fuel filter				◆

\* Perform after the initial 50 hours of operation ONLY, then on the regularly scheduled interval as indicated in the table above.

† Generac Mobile Products, LLC recommends that oil change intervals on the MLT6SM equipped with the Mitsubishi L3E-W461ML Tier 4 engine be extended to 1000 hours after initial break-in (if operating at high speed). The engine comes from the factory with a larger sump that holds 5.5 quarts (5.2 L) of engine oil. After the initial 50 hour break-in and oil change, the sump, coupled with the larger oil filter, allows the engine to operate up to 1000 hours between routine oil changes.

Hot, humid, or dusty conditions can shorten engine oil service life, regardless of suggested oil change intervals. In extreme conditions, determine oil life and change intervals through regular oil sampling and analysis.

Always follow the recommendations of the OEM engine manual that was shipped with the unit for specific operating instructions.

## Resetting the Maintenance Alarms

The Power Zone™ controller will display a warning message when the unit is due for maintenance or service. The maintenance or service interval is set at 750 hours of engine running time. Once the unit has been serviced, the appropriate maintenance alarm reminder needs to be reset. Proceed as follows to reset the maintenance alarms:

1. With the unit shut down, set the control power switch to ON (I). The controller will toggle automatically to the Home screen after initialization.
2. Press ↑ and ↓ simultaneously to enter the navigation menu.
3. Press ↑ or ↓ to move  to the top of the screen. Press ✓ to enter the Maintenance screen.
4. Press ↑ or ↓ to highlight the desired alarm that needs to be reset. Press ✓ to start reset.
5. Enter the pin 4444. To do this, press ✓ and then ↑ or ↓ to adjust the first number of the maintenance pin. Press ✓ to continue to the next number.

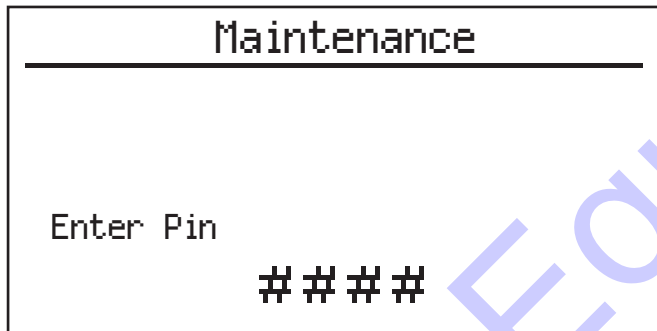

02026

Figure 4-1. Entering Maintenance Pin

## Winch Use, Operation, and Maintenance—Manual

### Prior to Use

- Inspect rope or cable, and replace if damaged.
- Inspect mounting hardware for correct tightness. Torque if necessary.
- Gears, ratchet pivot point, and shaft bushings must be kept lubricated with a thin film of oil or grease.

### Operation

#### Raising the Lights:

1. Verify the cable is securely fastened to the object being lifted and to the winch drum.
2. Verify the cable and cable attachments are not damaged. Contact a GMP ASD to order a replacement cable if necessary.

3. Referring to the “Lift / Let Down” decal on the winch, turn handle according to the specified direction to lift. The ratchet **MUST** make a loud clicking sound while winding the cable.

#### Lowering the Lights:

Referring to the “Lift / Let Down” decal on the winch, turn handle according to the specified direction to lower. No clicking will be heard because the brake system is activated.

### Maintenance

The following procedures should be performed at least annually:

1. The gears and bushings of the winch must be kept lubricated. Apply a thin film of grease to the gear teeth, and oil the bushings as needed.
2. The ratchet pawl pivot point must be kept lubricated with a thin oil.

**NOTE:** Do not get oil or grease on the brake mechanism.

## Winch Use, Operation, and Maintenance—Electric

- Keep the winch free of dirt, oil, grease, water, and other substances.
- Inspect all mounting bolts and verify they are tightened to the recommended torque values. Replace any damaged fasteners.
- Periodically inspect all connections to verify they are tight and free of corrosion.
- Inspect the cable for visible damage every time the winch is operated. Examples of damage are: cuts, knots, crushed or frayed portions, and broken strands. Replace cable immediately if damaged. Failure to replace a damaged cable could result in breakage.
- Regularly check the brake for slippage or drift. This is detected visually when winch is under load. If the winch drum continues to turn after controls are released, the brake may need to be replaced.
- Periodically clean and grease the brake assembly to ensure proper performance and extend the life of the winch. If winch seems to labor or get excessively hot during the lowering of loads, the brake will need to be serviced or replaced.
- Inspect motor brushes periodically and replace when necessary.

**NOTE:** Only the motor brushes and brake assembly require periodic replacement.

### Winch Mechanical Brake

The mechanical brake generates heat when loads are lowered and the wire cable is powered out. Care must be taken to avoid overheating the mechanical brake.

Whine or chatter associated with a new mechanical brake is normal and typically disappears with use.

Overheating the mechanical brake may result in permanent damage to, or failure of, the brake. Replace any damaged brake components before resuming use of the winch.

Maintenance Activity	After First Operation	Before Each Use	Semi-Annually
Inspect fasteners	◆		◆
Inspect electrical connections	◆		◆
Inspect condition of cables		◆	
Clean and grease brake assembly			◆
Inspect motor brushes			◆
Inspect winch and control	◆	◆	◆

### Trailer Wheel Bearings

The trailer axles are equipped with a Zerk grease fitting to allow lubrication of the wheel bearings without the need to disassemble the axle hub. Use only a high quality grease made specifically for lubrication of wheel bearings, such as Valvoline® W615 or equivalent.

Proceed as follows to lubricate the wheel bearings:

1. See **Figure 4-2**. Remove the small rubber plug (A) from the metal end cap (B).

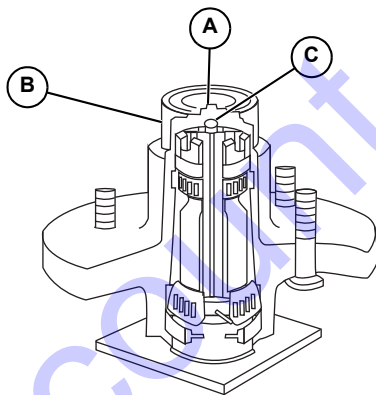

002540

**Figure 4-2. Wheel Bearing Cross Section**

2. Attach a standard grease gun fitting to the Zerk grease fitting (C).
3. Pump grease into the Zerk fitting until fresh grease is visible around the nozzle of the grease gun.
4. Wipe any excess grease from the axle hub with a clean cloth and install the rubber plug.

The minimum recommended lubrication is every 12 months or 12,000 mi (19,312 km). More frequent lubrication may be required under extremely dusty or damp operating conditions.

Every six months, or depending on usage, inspect for play in each bearing by jacking up the trailer, then trying to rock the wheel. If further assistance is required, contact Generac Mobile Products Technical Service at 1-800-926-9768.

### Jack Maintenance

Inspect each jack foot before each use for damage and remove any mud or debris. The jacks must be clean and in good operating condition to properly support the unit.

## Section 5: Troubleshooting

### General Troubleshooting

**WARNING**

Electrocution. Potentially lethal voltages are generated by this equipment. Render the equipment safe before attempting repairs or maintenance. Failure to do so could result in death or serious injury.

(000187)

**WARNING**

Risk of burns. Allow engine to cool before draining oil or coolant. Failure to do so could result in death or serious injury.

(000139)

**WARNING**

Equipment damage. Only qualified service personnel may install, operate, and maintain this equipment. Failure to follow proper installation requirements could result in death, serious injury, and equipment or property damage.

(000182a)

Some of the more common problems are listed in the following table. This information is intended to be a check or verification that simple causes can be located and fixed. It does not cover all types of problems. Refer to the OEM engine operator's manual for additional troubleshooting information. Procedures that require in-depth knowledge or skills should be referred to a GMP ASD.

Problem	Possible Cause	Solution
Unit cranks, but will not start	Low fuel level.	Verify fuel level in tank.
	Fuel flow obstructed.	Check fuel pump operation.
		Inspect fuel supply hose from tank to fuel filter for cracks and abrasion.
		Inspect for gelled fuel in fuel system in cold weather, especially at fuel filter.
	Air in fuel system.	Purge air from fuel system.
	Restricted air filter.	Inspect air filter for blockage.
Glow plug(s) inoperable.	Refer to OEM engine operator's manual for additional information.	
Unit starts, but stumbles and dies	Low ambient temperature.	Verify if ambient temperature is within unit limits.
	Intake heater inoperable.	Inspect engine air inlet heater functionality.
	Air in fuel lines.	Purge air from fuel lines.
High coolant temperature shutdown	Low coolant level.	Allow engine to cool, then check coolant level in radiator. Add coolant if needed.
	Blockage in radiator.	Inspect radiator surroundings for blockage and remove any foreign matter.
	Debris on radiator face.	
	Broken coolant pump belt.	Inspect for visible leaks. Check tension of water pump drive belt.
	Cooling fan inoperable.	Remove load on generator and restart engine.
Check coolant temperature and shut engine down immediately if it starts to overheat.		
Low oil pressure shutdown	Low oil level.	Check oil level. Add oil if necessary.
	Oil pump inoperable.	Contact a GMP ASD.
Unit stalls when export power is used	Load exceeds unit rating.	Turn outlet breaker ON and load sense switch OFF, confirm generator output is 60 Hz ± 2 Hz. Reapply load.
One or more lights do not turn on	Light breaker tripped.	Inspect light breakers.
	Lights not turned on.	Inspect electronic control to see if lights are on. Turn lights on.
The lights are flashing	Dusk-to-dawn sensor adjustment needed.	Adjust the dusk-to-dawn sensor according to <b><i>Dusk to Dawn Sensor</i></b> .
	Low generator frequency.	Verify AC frequency is >40hz.

# Section 6: Wiring Diagrams

## AC Wiring

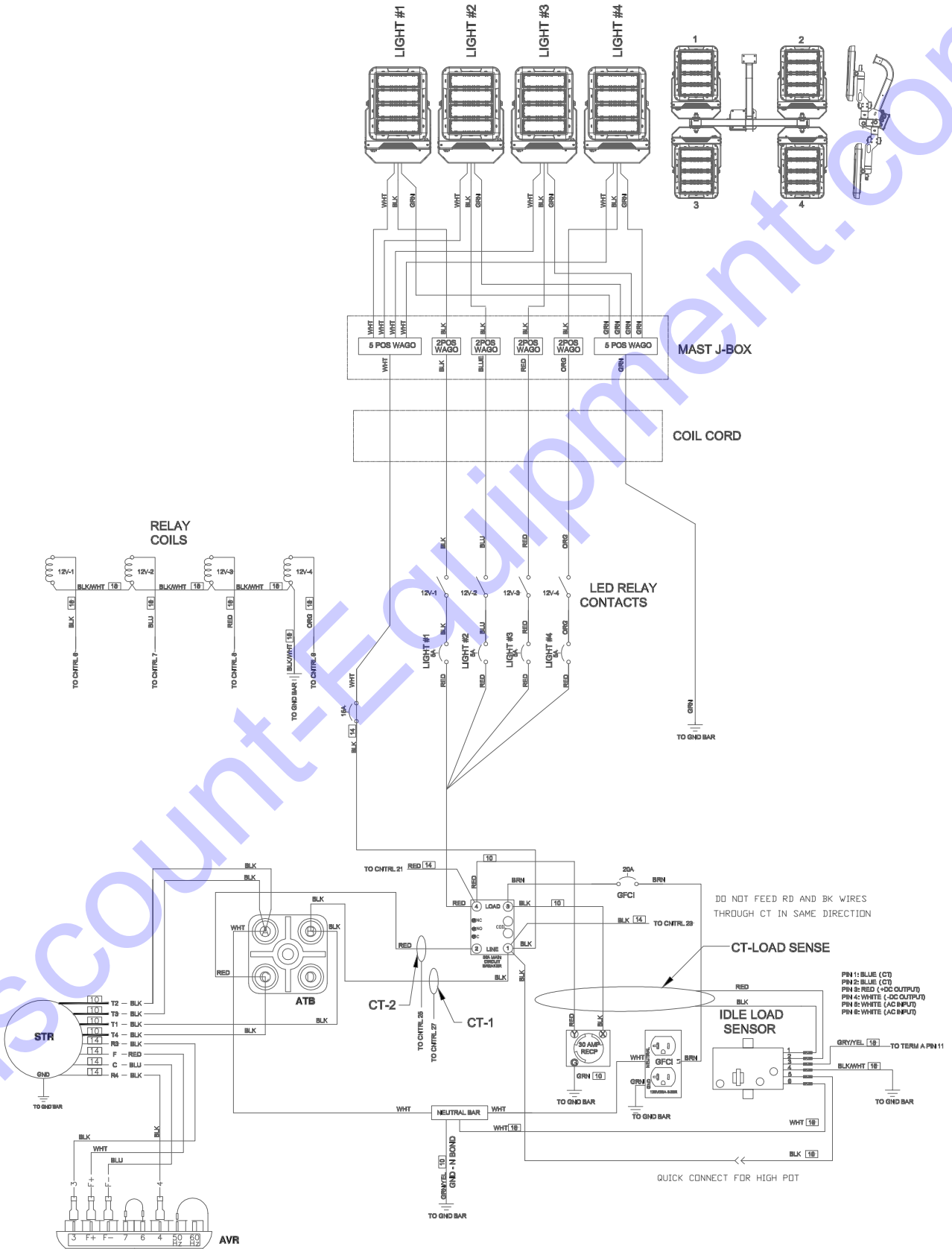

# DC Wiring—Control Box

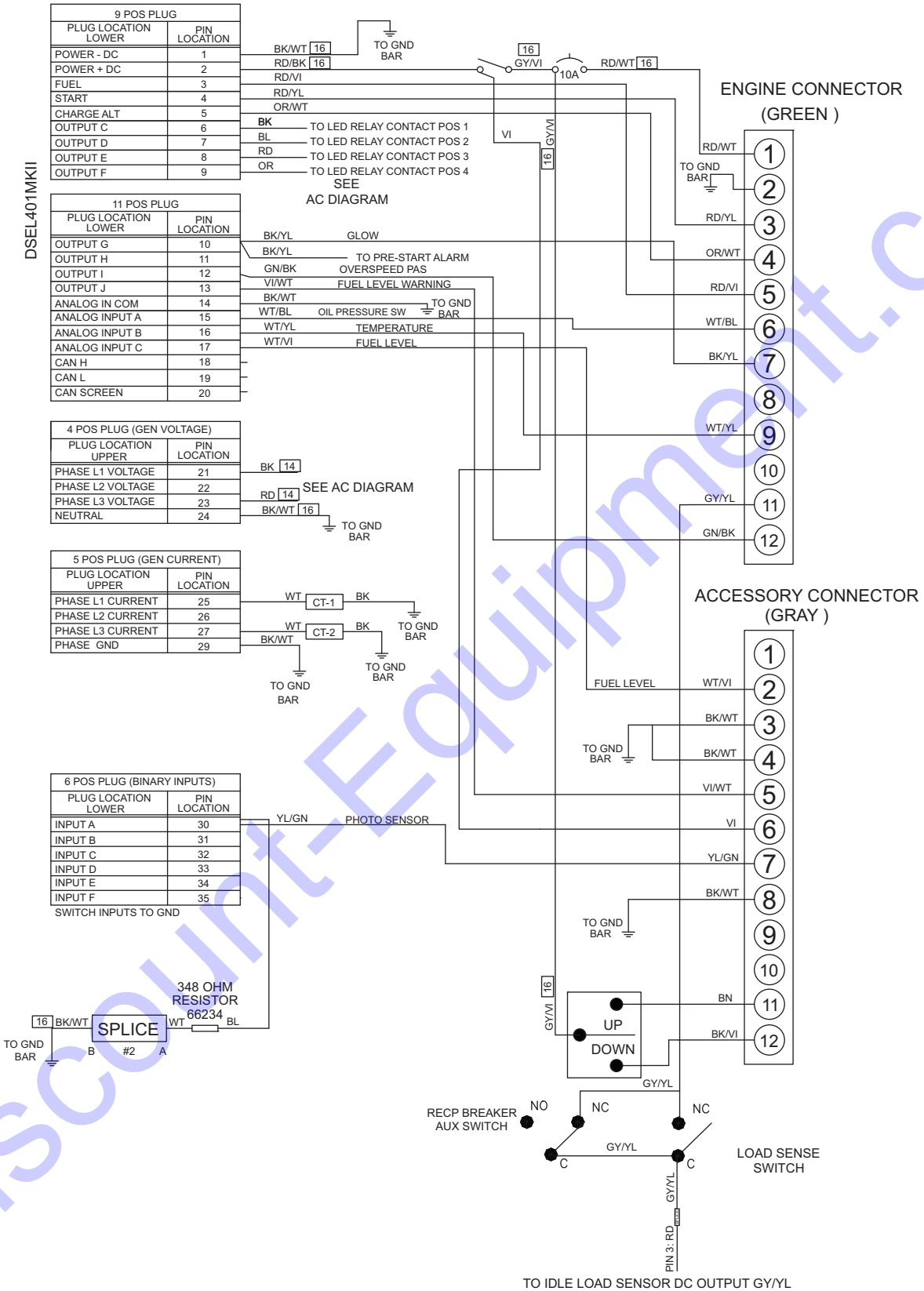

75013A\_H\_09.08.16



# DC Wiring

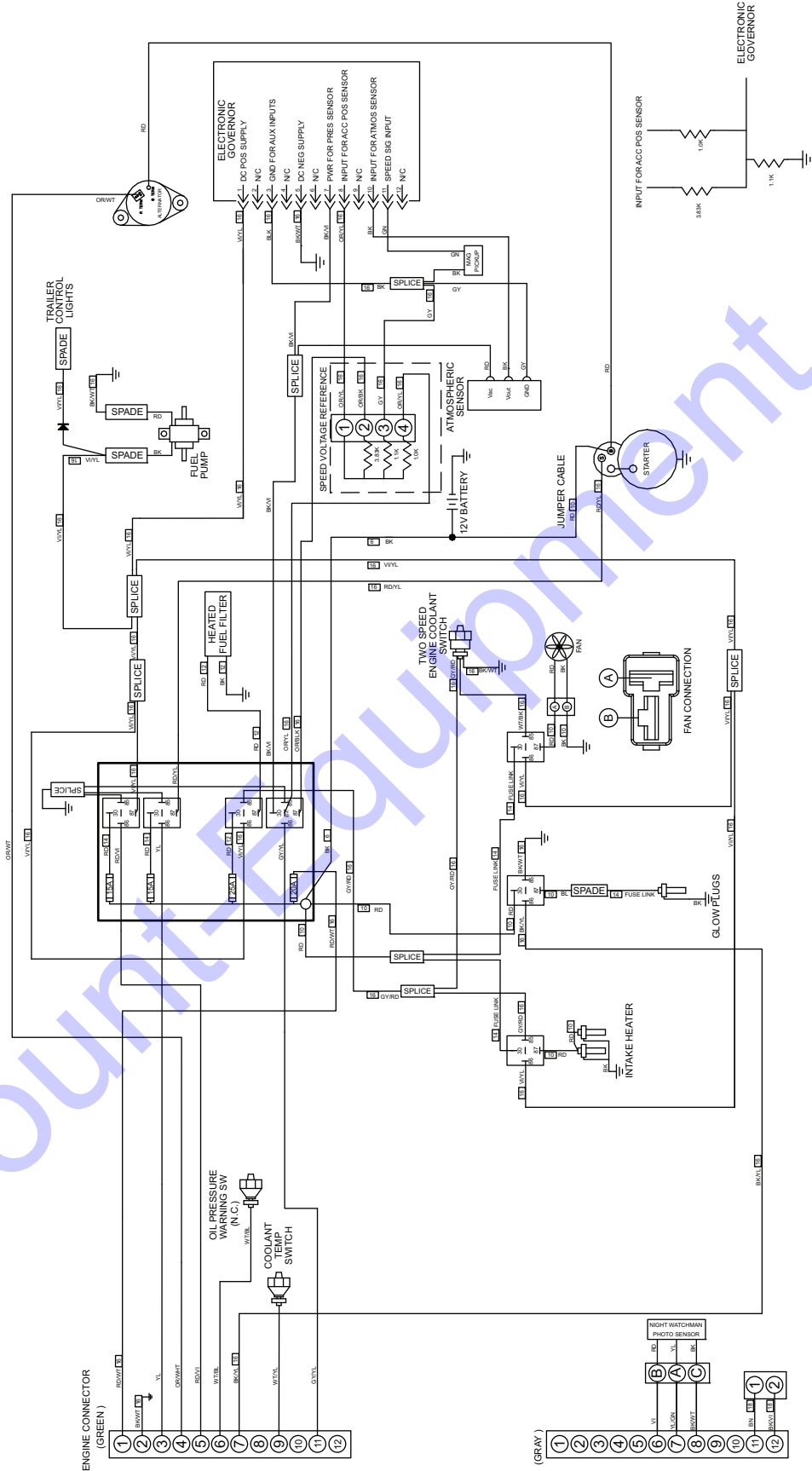

75013B\_H\_09.08.16

# DC Wiring—Electric Winch Option

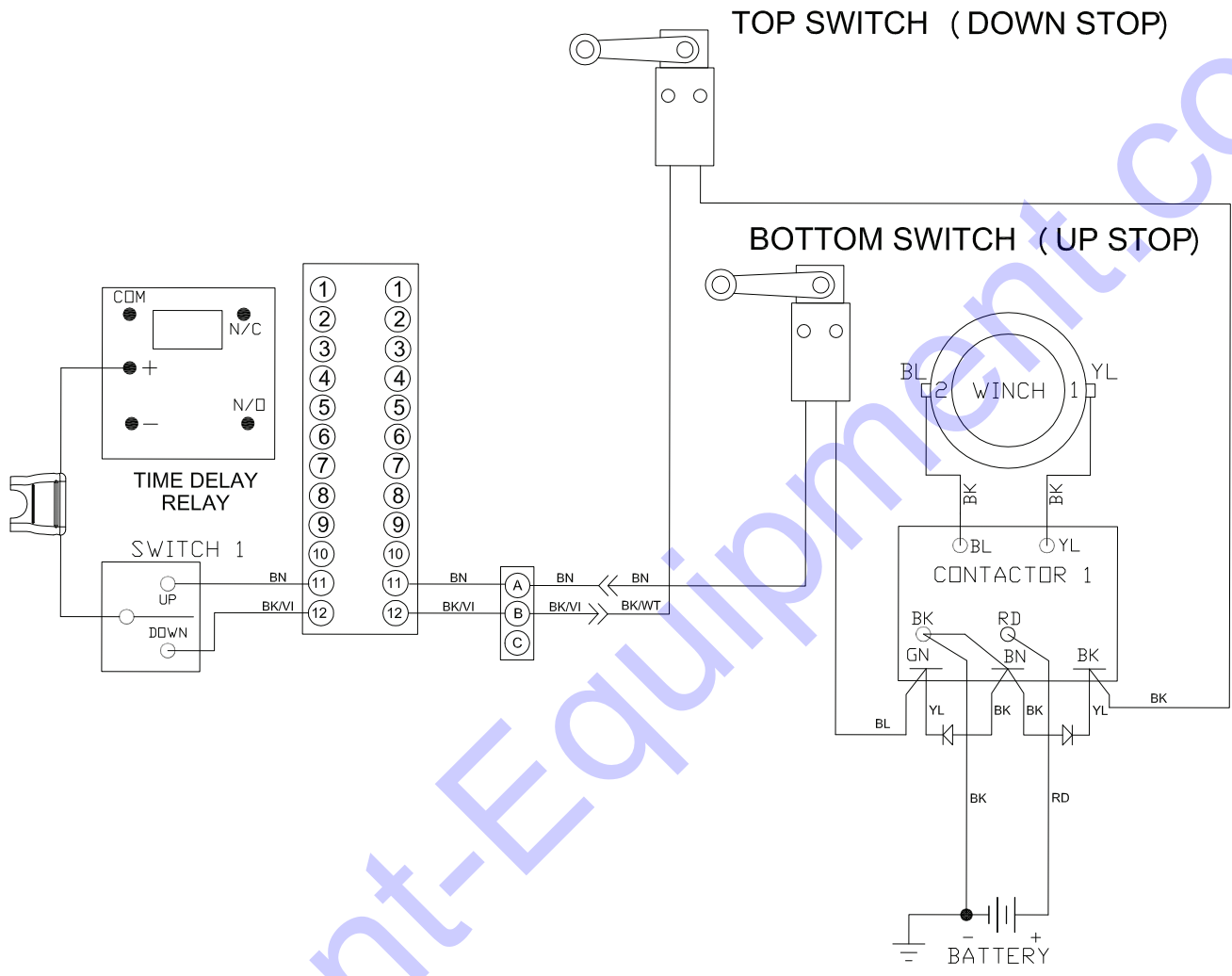

# Trailer Wiring

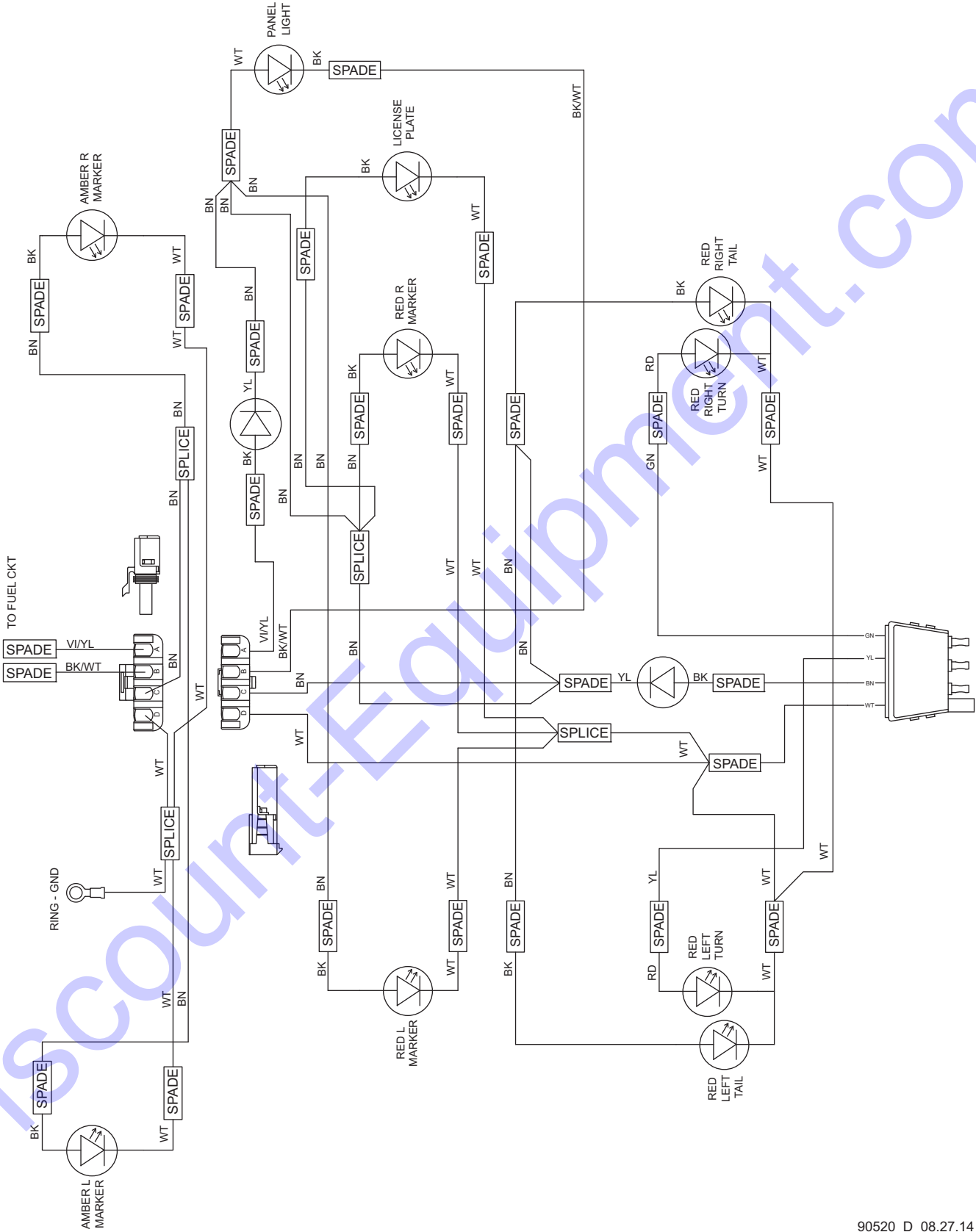

90520\_D\_08.27.14



[www.discount-equipment.com](http://www.discount-equipment.com)

Part No. 1000017442 Rev. E 10/05/18

©2018 Generac Mobile Products, LLC

All rights reserved.

Specifications are subject to change without notice.

No reproduction allowed in any form without prior written consent from Generac Mobile Products, LLC.

**GENERAC** | **MOBILE**