

# Allmand™



## Operator's Manual Maxi-Lite II® / Mine Spec® / Rig Spec®



# **Discount Equipment**

Discount-Equipment.com is your online resource for commercial and industrial quality parts and equipment sales.

## **Locations:**

Florida (West Palm Beach): [561-964-4949](tel:561-964-4949)

Outside Florida TOLL FREE: [877-690-3101](tel:877-690-3101)

**Need parts?** Check out our website at [www.discount-equipment.com](http://www.discount-equipment.com)

## **Can't find what you need?**

Click on this link: <http://www.discount-equipment.com/category/5443-parts/> and fill out the request form.

Please have the machine model and serial number available in order to help us get you the correct parts. One of our experienced staff members will get back to you with a quote for the right part that your machine needs.

We sell worldwide for the brands: Genie, Terex, JLG, MultiQuip, Mayco, Toro/Stone, Diamond Products, Magnum, Airman, Mustang, Power Blanket, Nifty Lift, Atlas Copco, Chicago Pneumatic, Allmand Brothers, Essick, Miller Spreader, Skyjack, Lull, Skytrak, Tsurumi, Husquvarna/Target, Whiteman-Concrete/Mortar, Stow-Concrete/Mortar, Baldor, Wacker, Sakai, Snorkel, Upright, Mi-T-M, Sullair, Neal, Basic, Dynapac, MBW, Weber, Bartell, Bennar Newman, Haulotte, Ditch Runner, Blaw-Knox, Himoina, Best, Buddy, Crown, Edco, Wyco, Bomag, Laymor, Terremite, Barreto, EZ Trench, Takeuchi, Basic, Bil-Jax, Curtis, Gehl, Heli, Honda, ICS/PowerGrit, Puckett, Waldon, ASV, IHI, Partner, Imer, Clipper, MMD, Koshin, Rice, Gorman Rupp, CH&E, Cat Pumps, Comet, General Pump, Giant, AMida, Coleman, NAC, Gradall, Square Shooter, Kent, Stanley, Tamco, Toku, Hatz, Kohler, Robin, Wisconsin, Northrock, Oztec, Toker TK, Rol-Air, Small Line, Wanco, Yanmar

**New Equipment - Used Equipment - Rental Equipment - Parts and Accessories**

# **Discount Equipment**

[www.discount-equipment.com](http://www.discount-equipment.com)

**561-964-4949**

Parts: [wbparts@Discount-Equipment.com](mailto:wbparts@Discount-Equipment.com)

Sales: [info@Discount-Equipment.com](mailto:info@Discount-Equipment.com)

## WARNING

Improper operation of this machine can cause death or serious injury.

Before transporting the trailer or starting the engine, do the following:

1. Read this owner's/operator's manual.
2. Read all safety decals on the machine.
3. Clear the area of other persons.

Learn and practice the safe use of the machine controls in a safe, clear area before you operate this machine on a worksite.

It is your responsibility to observe applicable laws and regulations, and to follow the manufacturer's instructions on machine operation and maintenance.

### California Proposition 65 Warning

The engine exhaust from this product contains chemicals known to the State of California to cause cancer, birth defects, or other reproductive harm.

### California Proposition 65 Warning

Battery posts, terminals, and related accessories contain lead and lead compounds - chemicals known to the State of California to cause cancer and reproductive harm. Wash hands after handling.

## IMPORTANT INFORMATION

Company Equipment Number: \_\_\_\_\_

Model Number: \_\_\_\_\_

Serial Number: \_\_\_\_\_

Engine Model Number: \_\_\_\_\_

Engine Serial Number: \_\_\_\_\_

Generator Model Number: \_\_\_\_\_

Generator Serial Number: \_\_\_\_\_



## TABLE OF CONTENTS

MAXI-LITE II / MINE SPEC / RIG SPEC

INTRODUCTION and OVERVIEW .....	1-1
SAFETY .....	2-1
USING THE LIGHT TOWER .....	3-1
MOVING THE LIGHT TOWER .....	4-1
MAINTAINING THE LIGHT TOWER TRAILER .....	5-1
SPECIFICATIONS .....	6-1
TROUBLESHOOTING .....	7-1
WARRANTY .....	W-1

Discount-Equipment.com





# INTRODUCTION and OVERVIEW

MAXI-LITE II / MINE SPEC / RIG SPEC

<b>ABOUT THIS MANUAL</b> .....	<b>1-2</b>
<b>PRODUCT OVERVIEW</b> .....	<b>1-3</b>
Laydown Tower- Front view .....	1-3
Laydown Tower- Rear view .....	1-4
Vertical Tower- Front view (Four-light tower).....	1-5
Vertical Tower- Rear view (Four-light tower) .....	1-6
Vertical Tower- Front view (Six-light tower) .....	1-7
Vertical Tower- Rear view (Six-light tower) .....	1-8
<b>CONTROL PANELS</b> .....	<b>1-10</b>
CONTROL PANEL OVERVIEW.....	1-10
ENGINE PANEL .....	1-10
LIGHT PANEL .....	1-11
AUXILIARY POWER PANEL.....	1-11
TYPES OF OUTLETS .....	1-12
<b>ADDITIONAL OPTIONS</b> .....	<b>1-14</b>

DiscountedEquipment.com



Congratulations on your purchase of a new Allmand light tower. Welcome to the Allmand Family of equipment owners.

The Allmand light tower offers many advantages to make operation safer, more convenient and more cost effective. It will give you high quality performance and durability for more productivity on the job site for many years.

## ABOUT THIS MANUAL

This *Operator's Manual* provides you with the information necessary to safely and efficiently operate your light tower.

**Before** you operate this machine, read this manual completely and carefully so that you understand the safety instructions and the operation of controls and safety equipment. You must comply with all **Danger**, **Warning**, and **Caution** notices. They are for your benefit.

Specific operating instructions and specifications are included to familiarize you (the operator) and the maintenance personnel with the correct and safe procedures necessary to operate and maintain this equipment in a safe and efficient manner.

Keep this manual in the manual storage canister on the machine.

**Save these original instructions for future reference.**

### Left Side/Right Side Orientation

Any reference in this manual to left side or right side shall be determined when viewing the machine from the rear. The front of the machine is that end having the light tower attached to it when the light tower is in the vertical position.

### Replacement Parts

For easy reference when ordering replacement parts or making service inquiries regarding this machine, record the model number and serial number of this machine, and the engine and generator models and serial numbers, in the "Important Information" area on the

inside of the front cover. The serial number for this machine is stamped on the serial number plate located on the lower right rear of the trailer.

Replacement of any part on this machine by anything other than an Allmand authorized replacement part may adversely affect the performance, durability, or safety of this machine.

### Disclaimer

Allmand Bros., Inc. reserves the right to make changes on, and add improvements to, its products at any time, without public notice or obligation. Allmand also reserves the right to discontinue manufacturing any product at its discretion, at any time.

The information found in this manual was in effect at the time it was printed. Allmand Bros. may change the contents of this manual at any time, without notice or incurring obligation.



## PRODUCT OVERVIEW

### Laydown Tower- Front view

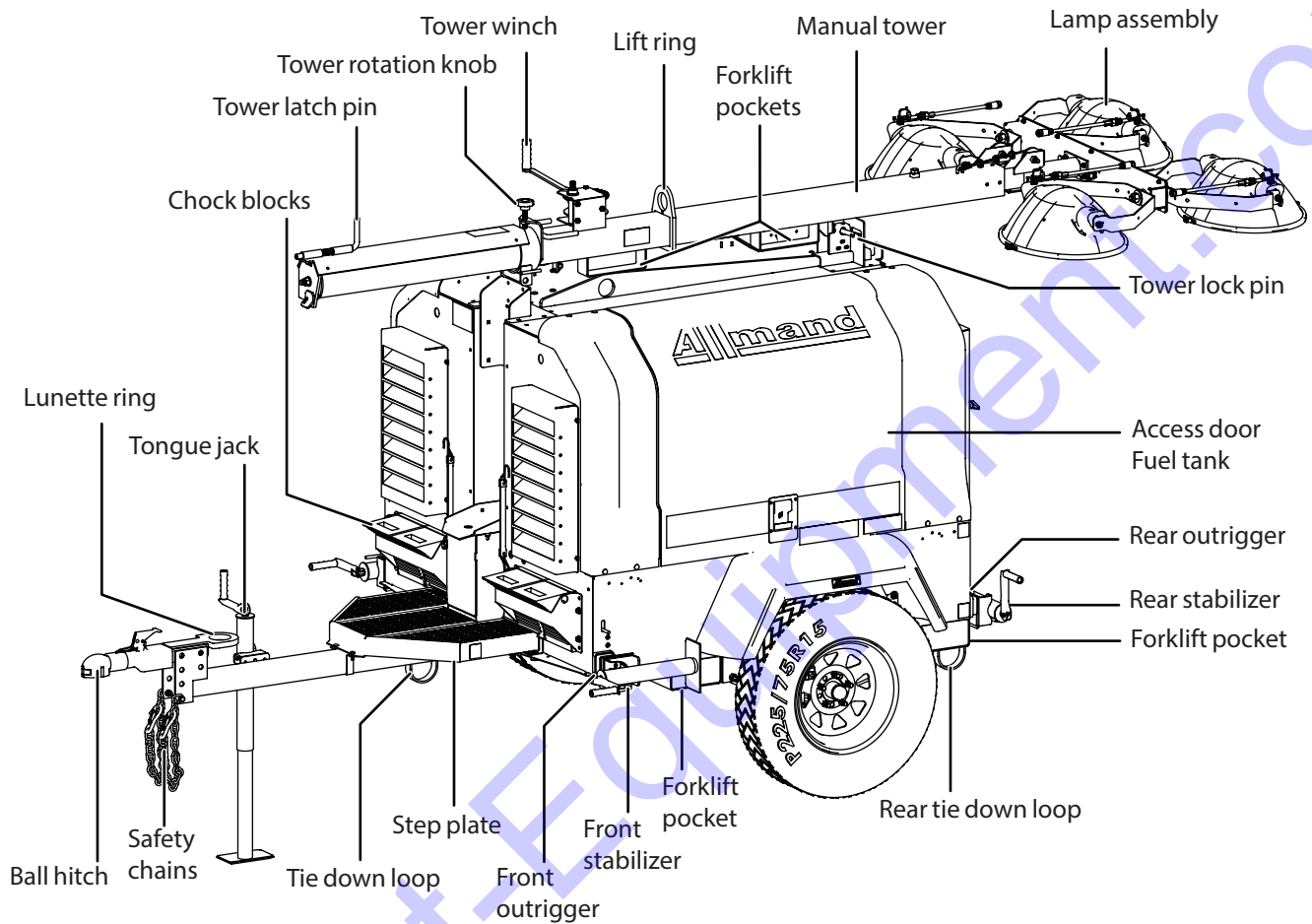

Laydown Tower- Rear view

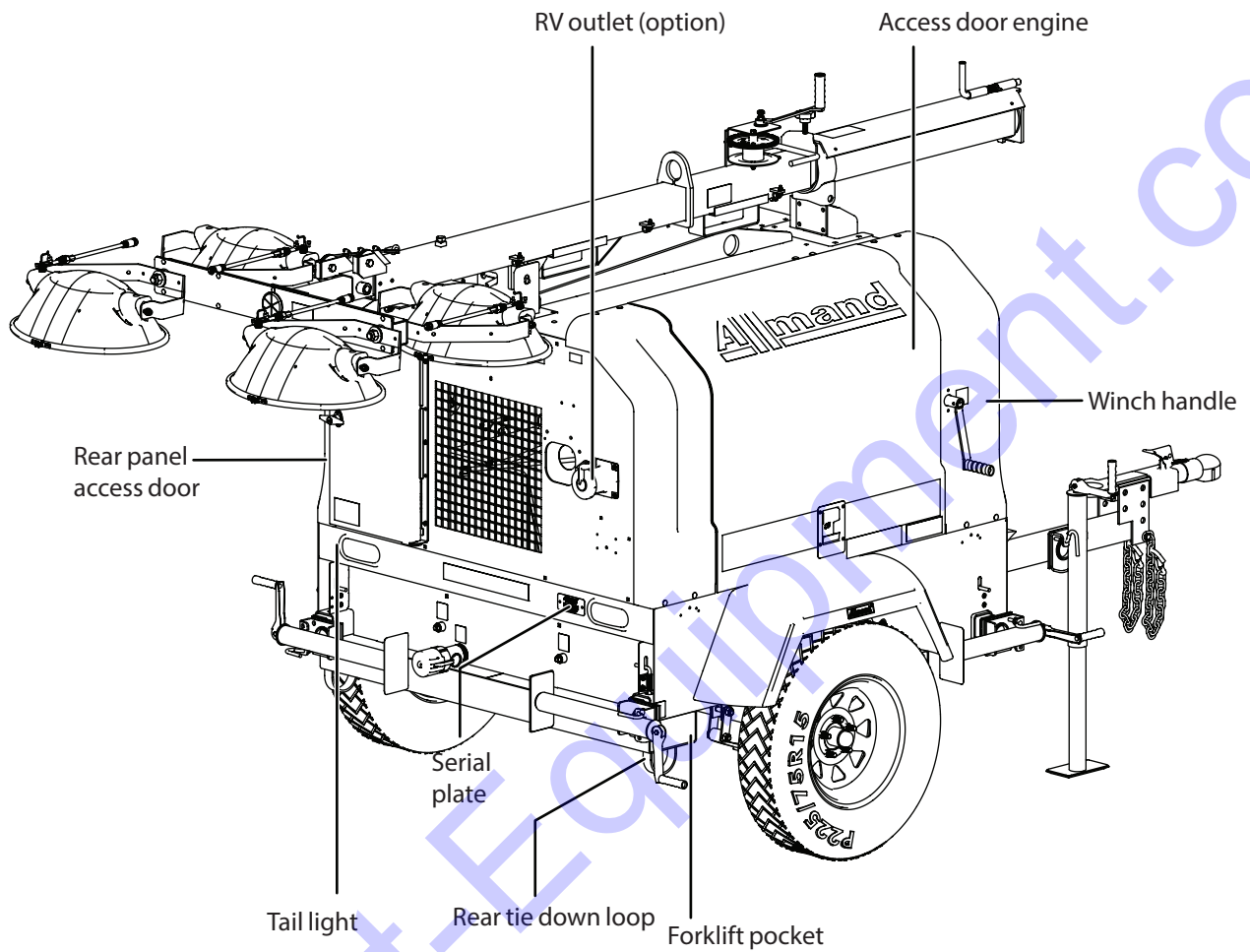



**Vertical Tower- Front view (Four-light tower)**

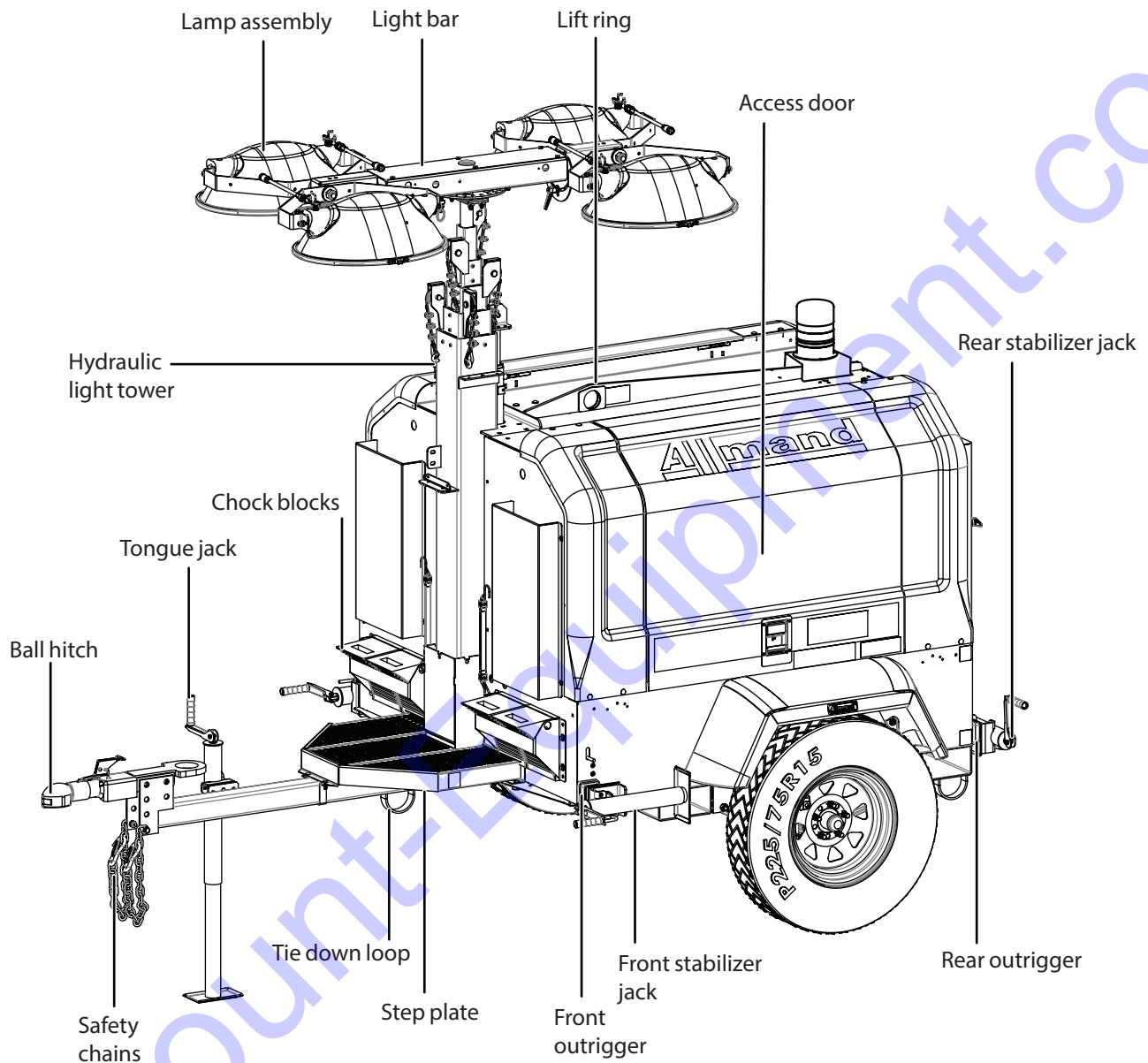

**Vertical Tower- Rear view (Four-light tower)**

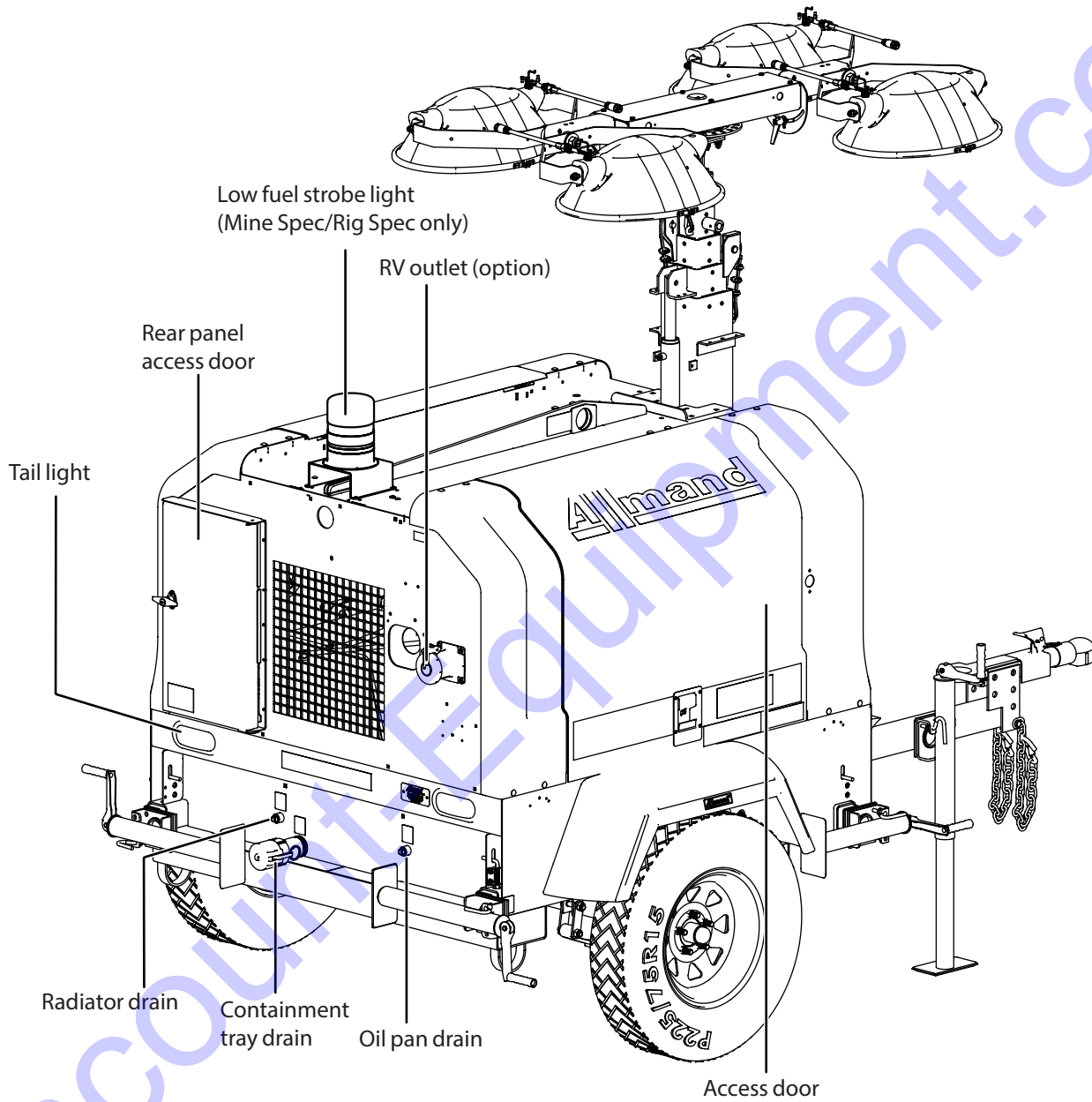

**Vertical Tower - Front view (Six-light tower)**

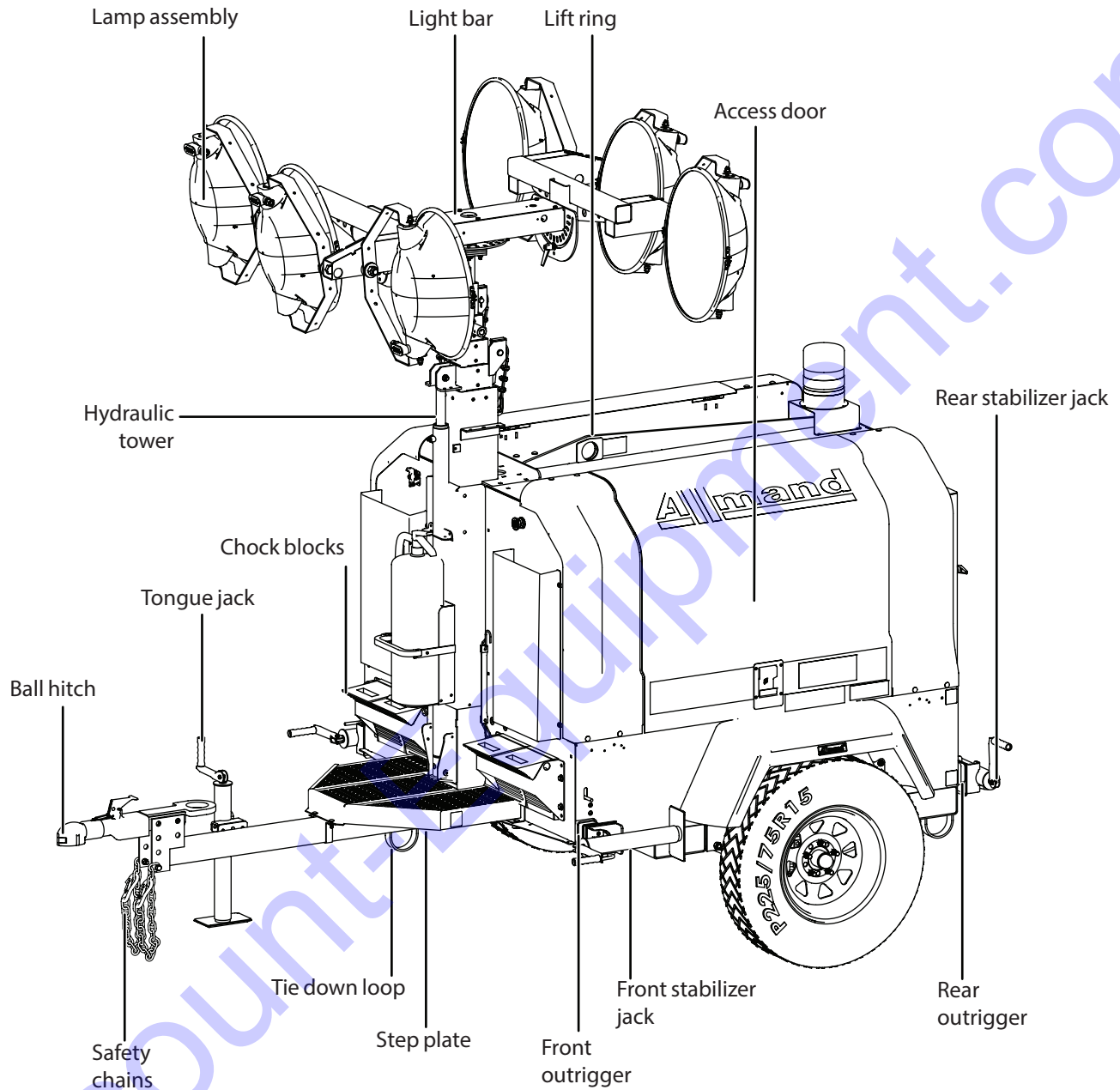

**Vertical Tower - Rear view (Six-light tower)**

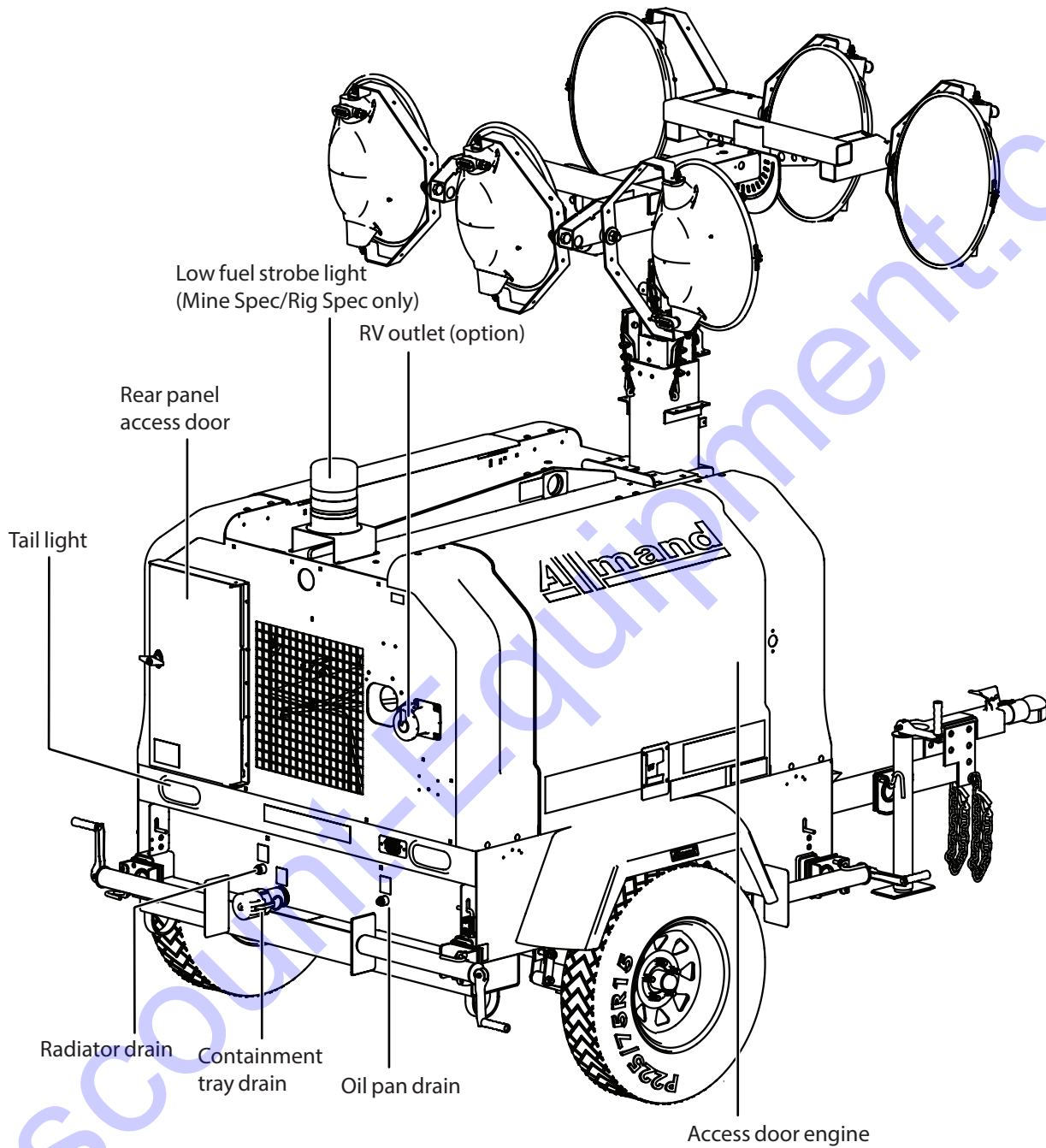

**Quick lock ball coupler**

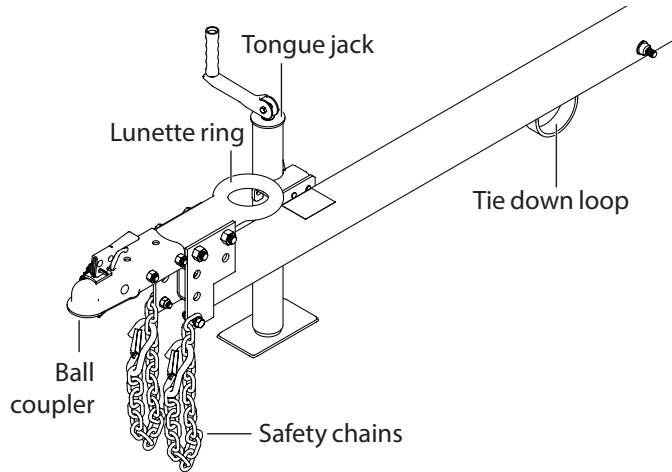

**Ball hitch**

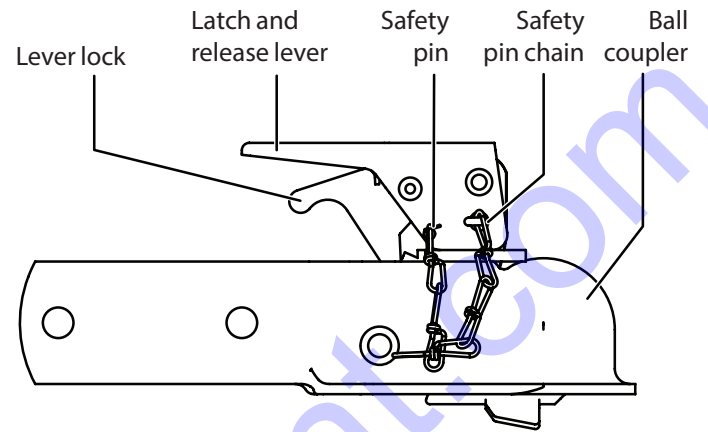

**Pintel hitch and lunette ring**

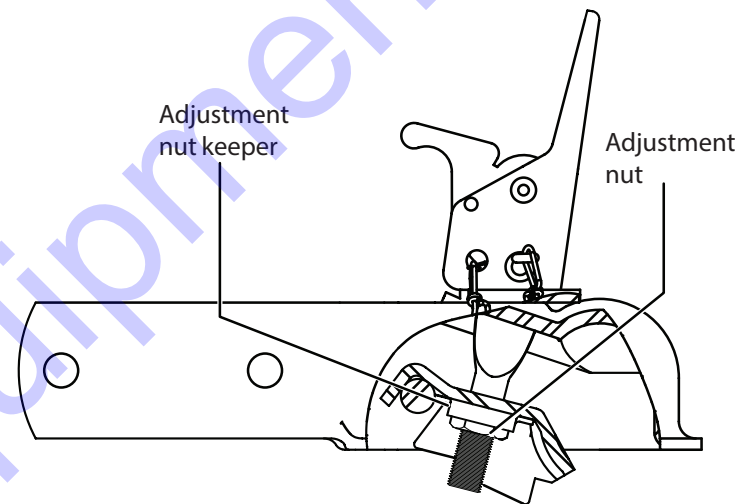
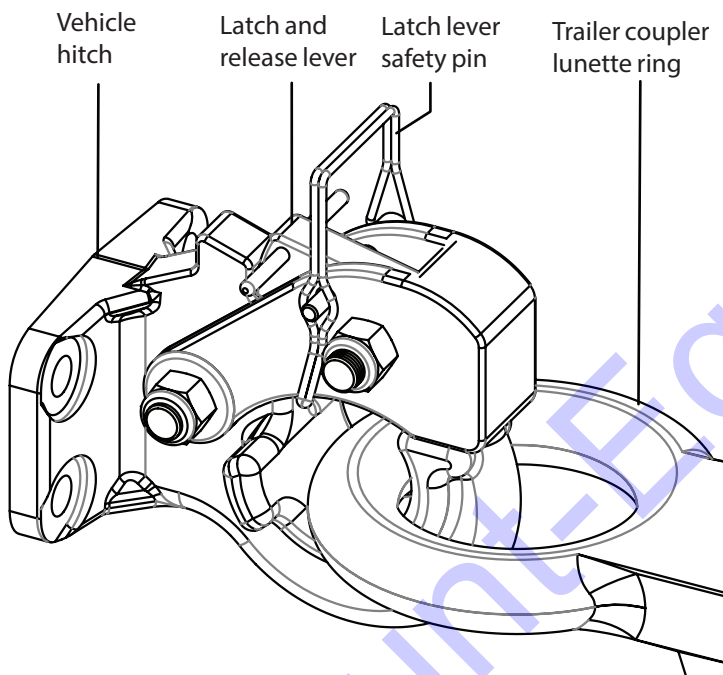

**Bulldog ball coupler**

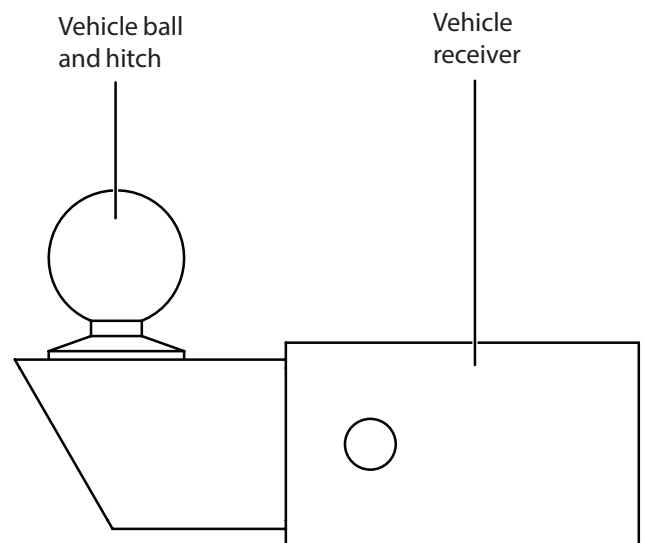
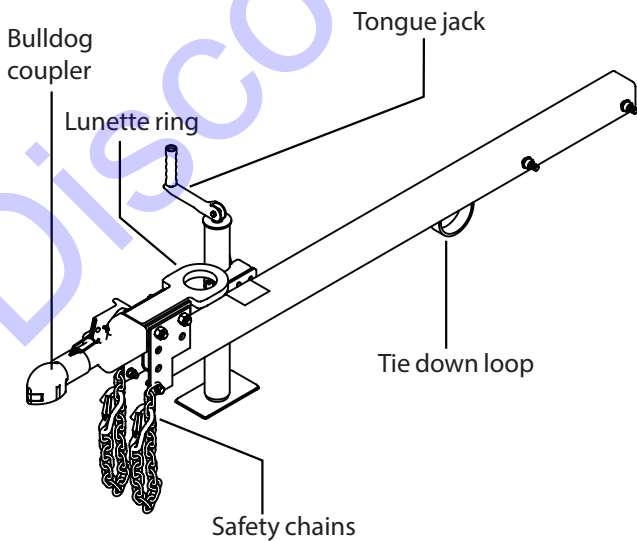

## CONTROL PANELS

### CONTROL PANEL OVERVIEW

The main control panel is actually composed of three sub-panels, which include the (1) engine panel which controls and provides information on the engine, the (2) light panel, which controls the tower lights, and the (3) auxiliary power panel, which provides power.

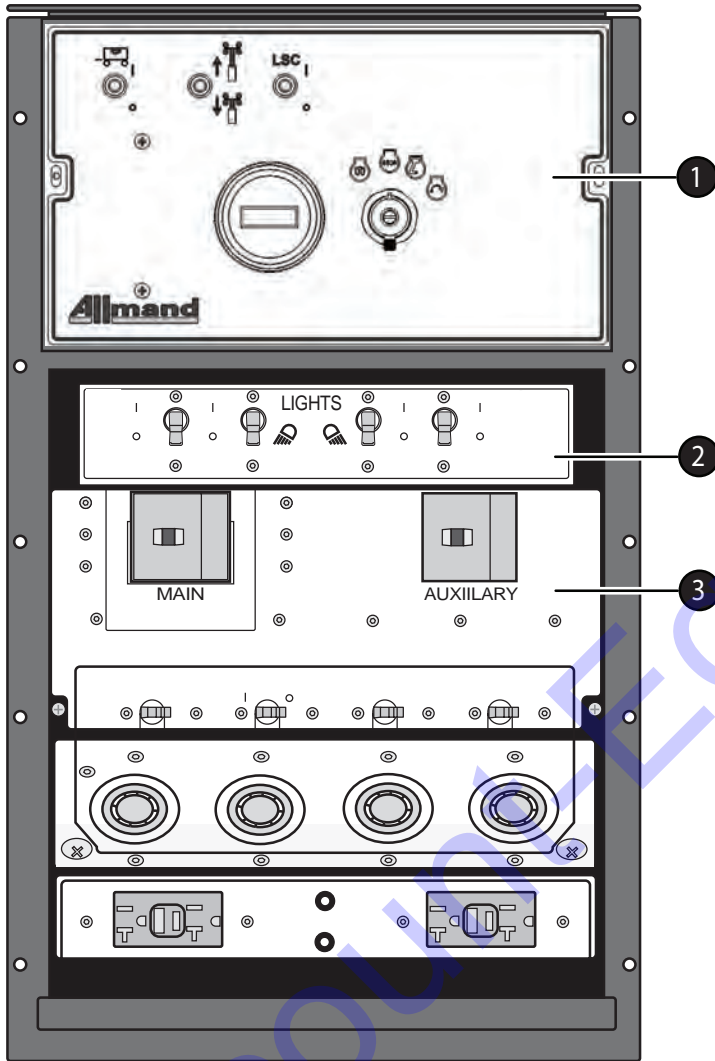

1	<b>Engine panel</b>	Controls engine functions.
2	<b>Light panel</b>	Controls light functions.
3	<b>Auxiliary power panel</b>	Includes the main electrical circuit breaker and controls all electric outlets.

### ENGINE PANEL

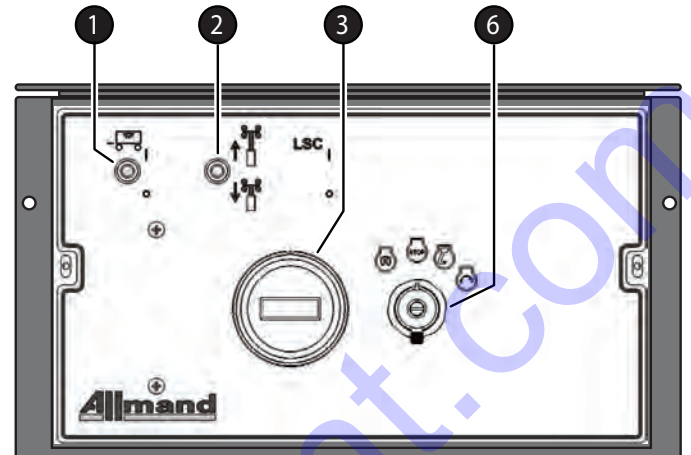

Standard

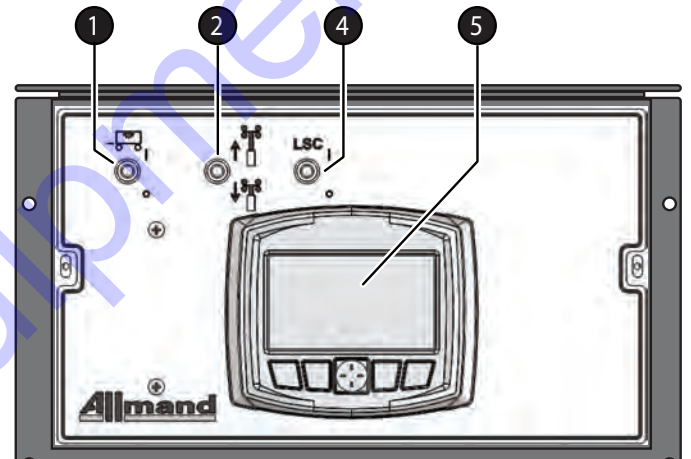

LSC 2.0 (Optional)

1	<b>Interior Light Switch (optional)</b>	Operates the interior light inside the trailer. The ignition key must be in the RUN position.
2	<b>Tower Raise / Lower Switch (vertical towers only)</b>	Move the switch UP to raise the tower, or DOWN to lower the tower. The ignition key must be in the RUN position.
3	<b>Hourmeter</b>	Indicates the total number of hours that the engine has been in operation. Operates only when the engine is running.
4	<b>LSC 2.0 Mode Switch (optional)</b>	Turns on power to the Light Sequencing Commander. See separate LSC 2.0 Operator's Manual for detailed instructions.

5	<b>LSC 2.0 Control (optional)</b>	The Light Sequencing Commander starts and stops the engine automatically. See separate LSC 2.0 Operator's Manual for detailed instructions.
6	<b>Ignition Switch</b>	Starts and stops the engine manually. Turn the switch to the left to preheat the engine before starting. Turn the switch to the right (RUN) to run the engine and accessories. Turn the switch all the way to the right (START) to start the engine.

**LIGHT PANEL**

The unit comes with either four or six lights and will come with a corresponding number of light switches.

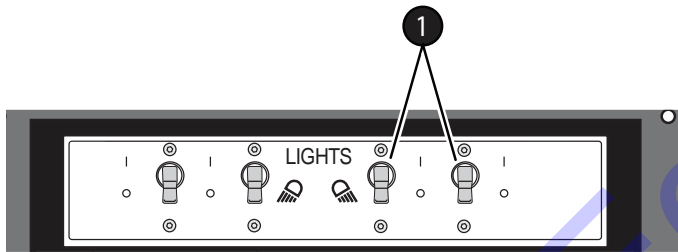

1	<b>Switches</b>	Switch to turn lights on or off. The switches also act as circuit breakers for the lights.
---	-----------------	--

For machines equipped with LSC 2.0 (option), the light switches must be in the ON position for automatic light control.

**AUXILIARY POWER PANEL**

The Main circuit breaker is located on the Auxiliary Power Panel. The Main breaker protects all the AC lights and outlets on the machine. It does not control the 12 Volt DC functions.

The Auxiliary circuit breaker(s), located on the Auxiliary Power Panel, protects the 50 Amp outlet(s) located on the right-rear panel of the machine, if the machine is so equipped.

The 240 Volt single phase or 208 Volt three phase outlets (if so equipped) are protected by circuit breakers immediately above each outlet.

The 120 Volt Ground Fault Circuit Interrupter (GFCI) outlets are duplex outlets. These are protected by push button breakers. The upper breaker protects the left side GFCI outlet and the lower breaker protects the right side GFCI outlet.

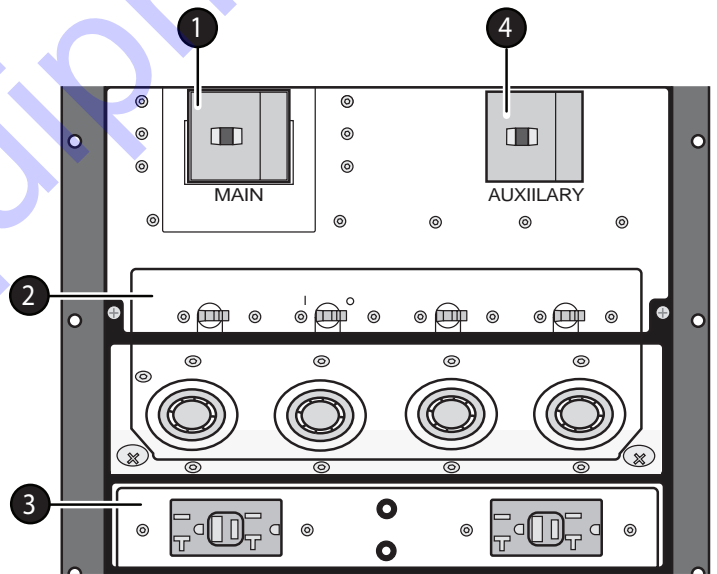

1	<b>Main breaker</b>	Protects all of the AC lights and outlets on the machine.
2	<b>240/208V outlets and breakers</b>	Outlets provide 240V/208V power. The breakers protect the outlets directly below them.
3	<b>120V GFCI outlets and breakers</b>	Outlets provide 120 V power, with Ground Fault protection. The push-button breakers protect the outlets.
4	<b>Auxiliary breaker(s)</b>	Protects the 50 A, 208V outlet(s) on the right side of the machine.

**TYPES OF OUTLETS**

There are a number of different outlets available on the unit. These can be in different combinations. Standard outlet configuration for the unit will depend on the generator output, but usually consists of:

- Two - 20 A, 120 V GFCI
- Two to four - 30 A, 240 V, four prong twist-lock

On machines with a three phase generator, a 50 A, 208 V outlet is included.

Your machine may be equipped with an outlet package specific for your needs. The outlets available on the unit are identified below:

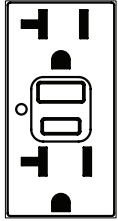

20 Amp, 120 Volt  
Duplex GFCI  
NEMA 5-20R

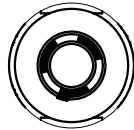

15 Amp, 125 Volt  
2-Pole, 3-Wire Twist Lock  
NEMA L6-15

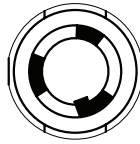

30 Amp, 250 Volt  
2-Pole, 3-Wire Twist Lock  
NEMA L6-30R

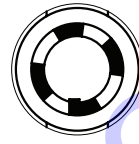

30 Amp, 125/250 Volt  
4-Pole, 4-Wire Twist Lock  
NEMA L14-30R

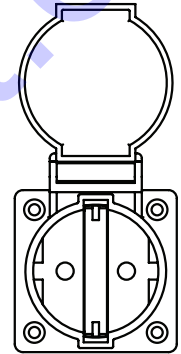

20 Amp, 250 Volt  
2-Pin, 3-Wire  
SCHUKO



50 Amp, 125/250 Volt  
3-Pole, 4-Wire  
CS6369 RECEPTACLE

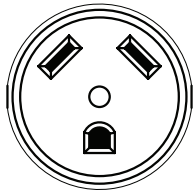

30 Amp, 125 Volt  
2-Pole, 3-Wire  
NEMA TT-30R (RV)



50 Amp, 125/250 Volt  
3-Pole, 4-Wire  
NEMA L14-50R (RV)

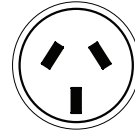

10 Amp, 240 Volt  
2-Pole, 3-Wire  
AU1-10

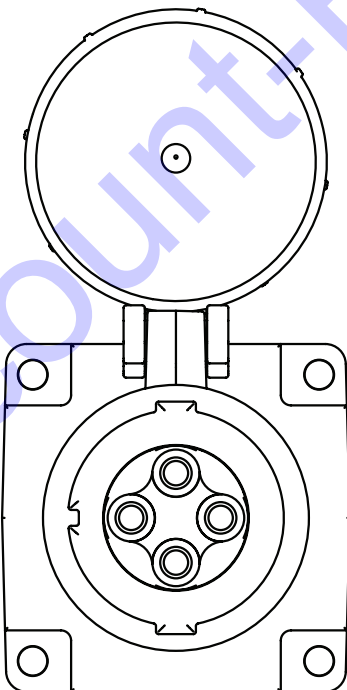

60 Amp, 600 Volt  
4-Pole, 5-Wire Pin and Sleeve

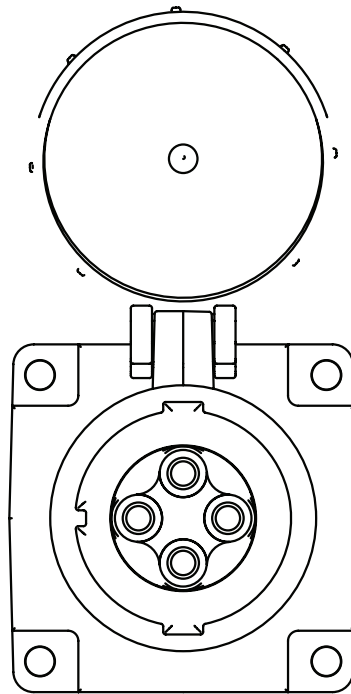

100 Amp, 600 Volt  
4-Pole, 5-Wire Pin and Sleeve



## GENERATORS

The following generators are available as options on the tower.

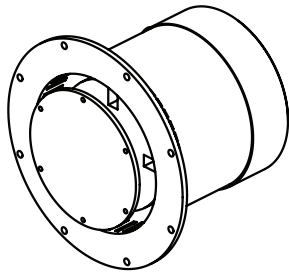

Mecca Alte Generator  
6/7.5 kW

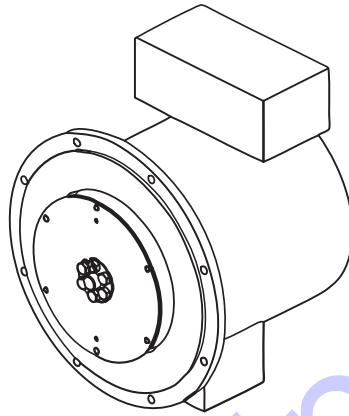

Mecca Alte Generator  
8 kW 60 Hz

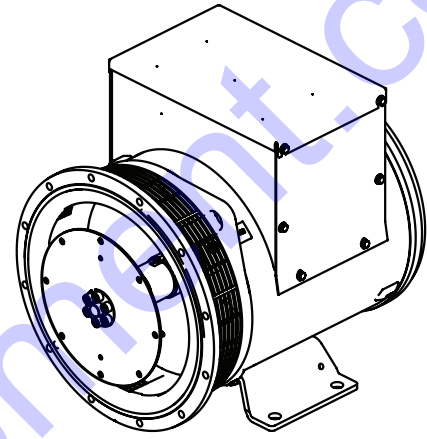

Marathon Generator  
13 kW

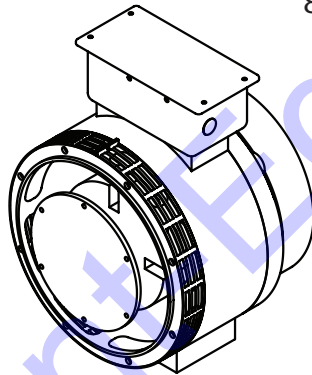

Marathon Generator  
8 kW 60 Hz AVR

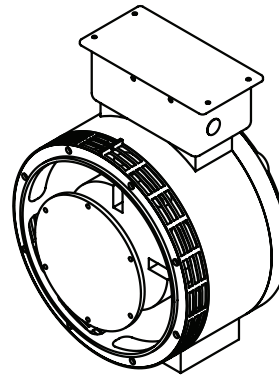

Marathon Generator  
6 kW 50 Hz AVR

DiscountEquipment.com

## ADDITIONAL OPTIONS

### Fire extinguisher \*

This is a 20-lb. multi-purpose dry chemical fire extinguisher, classified as a 10-A:120-B-C.

### Emergency stop switch \*

The emergency stop switch, or E-Stop, is a large button on the front of the machine that, when pressed, immediately shuts down the engine and all electric lights and outlets.

### Battery disconnect \*

The battery disconnect is a pad-lockable switch that renders the trailer inoperable by disconnecting the 12-volt battery from all systems on the trailer.

### Exhaust system blankets \*

The exhaust system blankets protect against exposure to high heat from the exhaust system.

### Wheel chocks\*

A set of four wheel chocks, and brackets to hold them on the front of the trailer, provide a convenient means of chocking the wheels to immobilize the trailer.

### Electric axle brakes

Electric axle brakes assist in slowing and stopping the trailer. Your tow vehicle must be equipped for operating the electric brakes and will need to have a 7-pole tail light harness.

### 7-pole tail light harness

The 7-pole tail light harness connects to the tow vehicle's trailer tail light receptacle and allows the operation of the trailer's turn signals, tail and running lights, brake lights, and electric brakes.

### Low fuel strobe light\*

When the fuel level in the fuel tanks is at approximately 1/8 full, the strobe light will begin blinking to indicate the fuel is low.

### Operational beacon

Provides a visible indication that the engine is running regardless of whether the lights are on or not.

### Heavy duty battery \*

The heavy duty battery has 33% more starting power at 0° F (-17° C) than the standard battery, for improved cold weather starting.

### Saf-T-Visor

Saf-T-Visors attach to the light fixtures and help to reduce the glare from the lights.

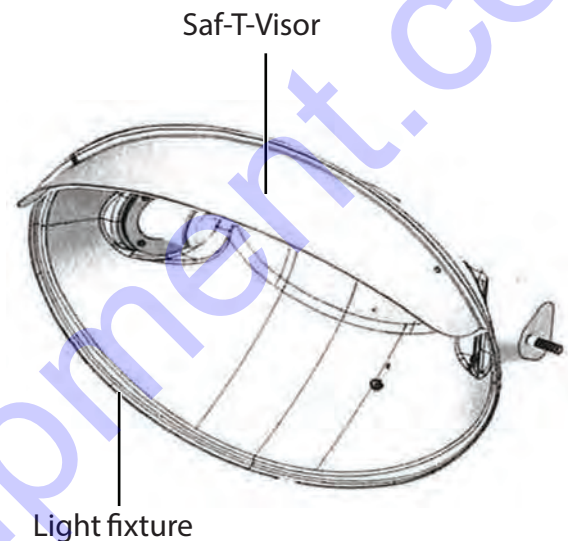

### Arctic Package

The arctic package is intended for machines used in extreme cold weather conditions. It includes a 110 Volt AC engine block heater, a 110 Volt AC battery heating blanket, a battery box, and an interior compartment light.

### Engine Air Intake Shutdown Valve\*

The Engine Air Intake Shutdown Valve automatically shuts down the engine in the event of an over-speed condition. A red T-handle, under the main side cover, allows for testing of the valve.

\* Standard Feature on Mine Spec / Rig Spec

**Vehicle Identification Number (VIN) package**

The VIN package includes side marker lights, front (amber) and rear (red), a license plate bracket and light, reflectors on the light tower, and the VIN tag.

MANUFACTURER BY / FABRIQUE PAR:		DATE:	
SPKS/PROV	KS (	LD)	
SAVY/PAGE	KS	TYPE/PAGE	INDI/DATE
FRONT / AVANT	KS LED		COIL INFL. PRES./PRES. DE GONFL. A FROID KPA SINGLE DUAL PUL/LPC <input type="checkbox"/> <input type="checkbox"/>
INTERM/ INTERM	KS LED		KPA SINGLE DUAL PUL/LPC <input type="checkbox"/> <input type="checkbox"/>
REAR / ARRIERE	KS LED		KPA SINGLE DUAL PUL/LPC <input type="checkbox"/> <input type="checkbox"/>

THIS VEHICLE CONFORMS TO ALL APPLICABLE U.S. FEDERAL MOTOR VEHICLE SAFETY STANDARDS IN EFFECT ON THE DATE OF MANUFACTURE SHOWN ABOVE.  
 THIS VEHICLE CONFORMS TO ALL APPLICABLE STANDARDS PRESCRIBED UNDER THE CANADIAN MOTOR VEHICLE SAFETY REGULATIONS IN EFFECT ON THE DATE OF MANUFACTURE. - CE VEHICULE EST CONFORME A TOUTES LES NORMES QUI LIH SONT APPLIQUEES EN VERTU DU REGLEMENT SUR LA SECURITE DES VEHICULES AUTOMOBILES DU CANADA EN VIGUEUR A LA DATE DE SA FABRICATION.

XLH/LLY: TYPE/TYPE: FD-226

**Cable management - vertical tower**

All units with vertical light towers can be equipped with either a Nycoil power cable or a cable reel. The Nycoil power cable is coiled around the tower mast. The cable reel has the power cable wrapped on the cord reel inside of it. Either system deploys automatically as the mast is raised and retracts automatically as the mast is lowered.

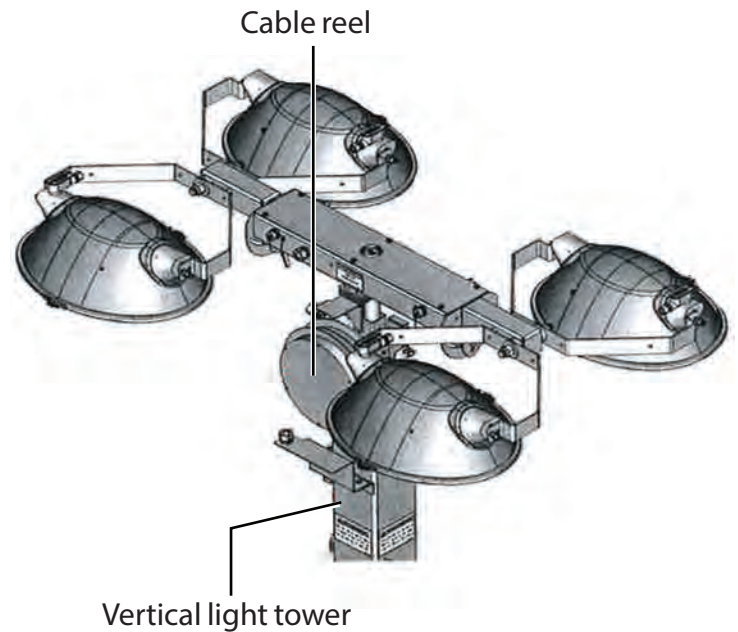
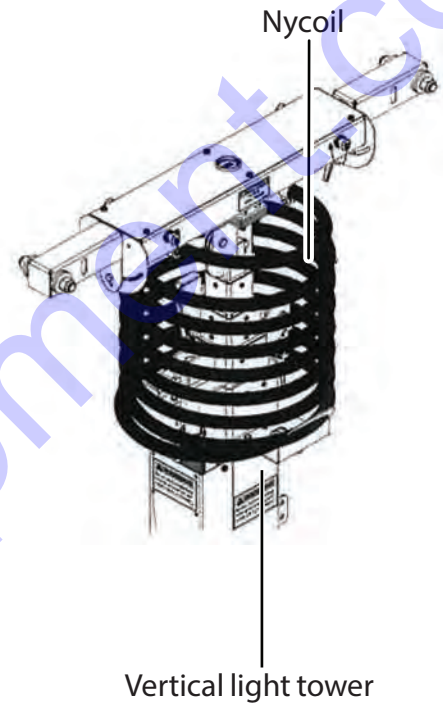

Discount-Equipment.com



## **SAFETY**

MAXI-LITE II / MINE SPEC / RIG SPEC

<b>SAFETY DEFINITIONS .....</b>	<b>2-2</b>
<b>SAFETY PRECAUTIONS .....</b>	<b>2-2</b>
<b>SAFETY HAZARDS AND WARNINGS .....</b>	<b>2-3</b>
<b>ELECTROCUTION HAZARD .....</b>	<b>2-3</b>
<b>UNSAFE OPERATION HAZARD .....</b>	<b>2-3</b>
<b>FALL HAZARD .....</b>	<b>2-3</b>
<b>MODIFICATION HAZARD .....</b>	<b>2-3</b>
<b>EXPOSURE HAZARD .....</b>	<b>2-3</b>
<b>ROLLOVER HAZARD .....</b>	<b>2-3</b>
<b>EXPLOSION HAZARD.....</b>	<b>2-4</b>
<b>FIRE HAZARD.....</b>	<b>2-4</b>
<b>EXHAUST HAZARD.....</b>	<b>2-4</b>
<b>ENTANGLEMENT/SEVER HAZARD .....</b>	<b>2-4</b>
<b>PIERCING HAZARD.....</b>	<b>2-4</b>
<b>PIERCING HAZARD.....</b>	<b>2-4</b>
<b>FLYING OBJECT HAZARD .....</b>	<b>2-4</b>
<b>BURN HAZARD .....</b>	<b>2-5</b>
<b>BURN HAZARD .....</b>	<b>2-5</b>
<b>SLIPPING OR TRIPPING HAZARD .....</b>	<b>2-5</b>
<b>DECALS AND SAFETY LABELS.....</b>	<b>2-6</b>
<b>OPERATION ICONS.....</b>	<b>2-9</b>

DiscountEquipment.com

## SAFETY DEFINITIONS

Safety statements are one of the primary ways to call your attention to potential hazards. Review and become familiar with the various precautions included throughout the manual. We recommend that you do this before operation, during operation, and during periodic maintenance procedures. This is extremely important for your safety and the safety of others, and to avoid damage to your equipment.

Keep all equipment information and safety decals clean and visible and replace them if they become damaged or unreadable. Also, if a part needs to be replaced that has a decal attached to it, make sure to order the new part and decal at the same time.



This safety alert symbol appears with most safety statements. It means pay attention, become alert, your safety is involved! Read and abide by the message that follows the safety alert symbol.

### DANGER

Indicates a hazardous situation which, if not avoided, **will** result in death or serious injury.

### WARNING

Indicates a hazardous situation which, if not avoided, **could** result in death or serious injury.

### CAUTION

Indicates a hazardous situation which, if not avoided, **could** result in minor or serious injury.

### NOTICE

Indicates a situation which can cause damage to the equipment, personal property, and/or the environment, or may cause the equipment to operate improperly. Also included to make procedures easier or clearer.

## SAFETY PRECAUTIONS

There's no substitute for common sense and safe, careful work habits. This information contains general safety precautions and guidelines that must be followed to reduce the risk of injury to you and others. Special safety precautions are listed in specific procedures. Read and understand all of the safety precautions before operating the machine or performing repairs or maintenance on your equipment.

This safety section can't cover every situation that may occur in the use of the equipment. If you are uncertain about any of the information or any procedure in the manual, contact Allmand service department at 1-800-562-1373, for clarification. Your safety is important to us and we're happy to help.

## SAFETY HAZARDS AND WARNINGS

### DANGER



The safety messages that follow have **DANGER** level hazards.

#### ELECTROCUTION HAZARD



- Contact with overhead electrical wires will result in death or serious injury. Always maintain a minimum distance of 45 ft. (14 m) from overhead wires to light tower.
- Servicing electrical components while the engine is running will result in death or serious injury. Always shut down the engine before servicing electrical components.
- Capacitors are capable of discharging high voltage that will result in death or serious injury. Always shutdown the engine, then discharge capacitors by grounding them with an insulated device.
- Contact with wires that have been made bare by damaged, cut, or worn insulation will result in death or serious injury. Always replace damaged wiring before starting the engine or operating the light tower.



The safety messages that follow have **WARNING** level hazards.

#### UNSAFE OPERATION HAZARD

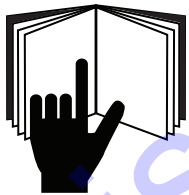

- Untrained personnel operating this equipment could result in death or serious injury. Read and understand the Operators Manual before operating or servicing this equipment.
- Use of alcohol or drugs while operating or attempting to operate this machine could result in death or serious injury. Never operate this machine while under the influence of alcohol, drugs, or when otherwise impaired.
- Failure to replace safety decals or instructions that have become damaged or torn could result in death or serious injury. Always replace decals that are damaged, torn, or otherwise illegible.

- Failure to replace worn, broken, or defective parts could result in death or serious injury. Always inspect the machine prior to use and replace any part that is broken, defective, or not within specifications.

#### FALL HAZARD

Falling from moving equipment could result death or serious injury. Never ride, or carry riders, on this equipment.

#### MODIFICATION HAZARD

Unauthorized modification of the light tower trailer could result in death or serious injury. Never modify the light tower trailer without consulting the Allmand Service Department.

#### CRUSH HAZARD

Standing or walking under elevated equipment could result in death or serious injury. When elevating or lifting the trailer, always keep clear of the area around and under the trailer, and do not allow others in the area.

#### EXPOSURE HAZARD



Failure to wear appropriate personal protective equipment could result in death or serious injury. Always wear personal protective equipment including appropriate clothes, gloves,

work shoes, and eye and hearing protection, as required for the task at hand.

#### ROLLOVER HAZARD

- Raising the light tower without properly positioning the outriggers and stabilizer jacks first could cause machine rollover, resulting in death or serious injury. Always position the outriggers and stabilizer jacks on a smooth, level, and stable surface before raising the light tower.
- Attempting to move or lift the trailer with the light tower raised could cause machine rollover, resulting in death or serious injury. Always lower the light tower to its fully lowered position before moving or lifting the trailer.

- Operating the light tower fully raised in winds exceeding 53 mph (85 km/h) can cause machine rollover resulting in death or serious injury. Always lower the light tower when winds are expected to exceed 53 mph (85 km/h).

### EXPLOSION HAZARD



- Smoking, open flame, or other forms of ignition near the battery could cause an explosion, resulting in death or serious injury. Always keep smoking materials, open flame, and other forms of ignition away from the battery.
- Failure to follow the correct procedure for jump starting could cause a battery explosion, resulting in death or serious injury. Always follow the proper procedure for jump starting the engine.
- Attempting to jump start or charge a frozen battery could cause an explosion, resulting in death or serious injury. Always be sure that the battery is not frozen, split open or damaged before attempting to charge or jump start it.

### FIRE HAZARD

- Smoking, open flame, or other forms of ignition near the diesel fuel could cause a fire, resulting in death or serious injury. Always:
  - Keep smoking materials, open flame, and other forms of ignition away from fuel.
  - Shut down engine before refueling.
  - Clean up fuel spills immediately.
  - Use an appropriate container, rather than shop rags, to catch fuel when performing service or maintenance.
  - Store any containers containing fuel in a well ventilated area, away from combustibles or sources of ignition.

### EXHAUST HAZARD



Operating the engine in a non-ventilated, enclosed area could result in death or serious injury. Always operate the engine in a well-ventilated area.

### ENTANGLEMENT/SEVER HAZARD



Contact with moving or rotating parts of the machine could cause death or serious injury. Always:

- Verify that all guards and covers are attached properly to the machine before starting the engine.
- Remove jewelry, tie back long hair, and keep hands, other body parts, and clothing away from moving or rotating parts.
- Follow your companies "Lock Out, Tag Out" procedure, or attach a "Do Not Operate" tag in a prominent place on the machine prior to performing service or maintenance on the machine.

### PIERCING HAZARD



Hydraulic fluid or diesel fuel under high pressure can penetrate skin, resulting in death or serious injury. Always use a piece of cardboard or wood to check for hydraulic or fuel leaks, and never use

your hands.

### CONTROL HAZARD

An underrated tow hitch could cause loss of control of the towing vehicle or trailer, resulting in death or serious injury. Always:

- Make sure that the vehicle's towing capacity exceeds that of the trailer load.
- Make sure that the vehicle's hitch and ball are rated to accept the trailer load, and are the appropriate size for the trailer coupler socket.
- Make sure that safety chains are properly and securely attached between the tow vehicle and the trailer, and do not let them drag on pavement. Dragging safety chains on the road surface could cause them to fail in an emergency, resulting in death or serious injury.

### FLYING OBJECT HAZARD



Exposure to flying debris, pressurized steam or water, and compressed air could result in death or serious injury. Always wear eye protection when working around or cleaning the machine.

**BURN HAZARD**

Contact with light fixtures in use or immediately after they have been switched off could result in death or serious injury. Always allow lights to cool before handling, and wear heat-resistant gloves.

- Rapid release of hot coolant under pressure could result in death or serious injury. Use extreme caution when opening the radiator cap, and always wear eye protection and heat resistant gloves.

**CAUTION**

The safety messages that follow are **CAUTION** level hazards.

**SLIPPING OR TRIPPING HAZARD**

- Spilled liquids on the shop floor could cause a slip hazard, resulting in minor or serious injury. Immediately clean up any spilled fuel, lubricants, or other liquids.
- Dirt and debris on the shop floor could cause a tripping hazard, resulting in minor or serious injury. Always clean up accumulated dirt and debris and pick up tools on the shop floor as soon as practical.

**NOTICE**

Please take note of the following items. While not hazards, these items do deserve your attention.

**WARNING LIGHTS**

Stop the engine immediately if any warning light turns on. Determine the reason for the warning and repair the problem before continuing to operate the equipment.

**PARTS AND REPAIR**

- Always use genuine Allmand replacement parts. Other replacement parts may not perform adequately, may cause a safety hazard, and may affect warranty coverage.
- Always tighten screws, nuts, and bolts to the specified torque. Loose fasteners can cause equipment damage or improper operation.
- Retrieve any tools or parts that may have dropped inside of the equipment, to avoid improper equipment operation or damage to the equipment.

**EQUIPMENT CLEANLINESS**

Clean accumulated dirt and debris from the outside of the trailer, and from internal components, before you inspect the machine or perform maintenance or repairs. Operating your light tower trailer with accumulated dirt and debris will cause premature wear of equipment components.

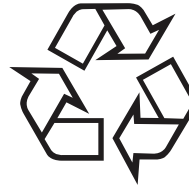
**DISPOSAL OF HAZARDOUS MATERIALS**

Always dispose of hazardous materials properly at an approved recycling facility. Follow the federal EPA guidelines and the guidelines of state and local environmental protection agencies for the proper disposal of engine oil, diesel fuel, and engine coolant.



## DECALS AND SAFETY LABELS

### WARNING





Failure to replace safety decals or instructions that have become damaged or torn could result in death or serious injury. Always replace decals that are damaged, torn, or are otherwise illegible.



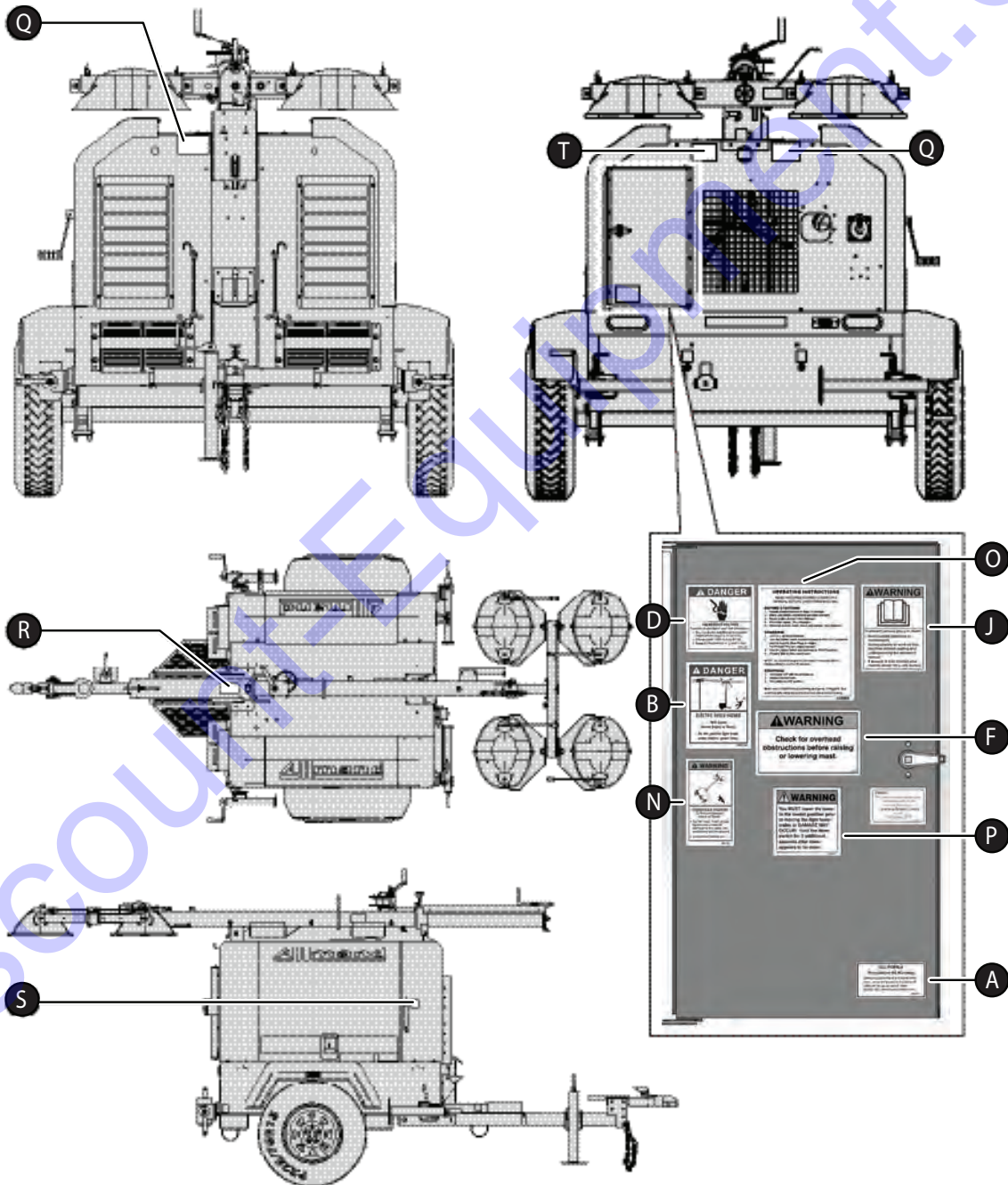

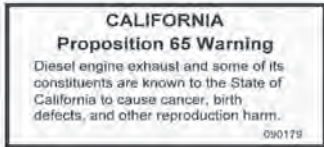
Keep all equipment information and safety decals clean and visible and replace them if they become damaged or unreadable. Refer to the tables on the following pages to identify the label you want to replace. Call the Allmand Parts Department at 1-800-562-1373 to order replacement decals.





### LABEL LOCATIONS



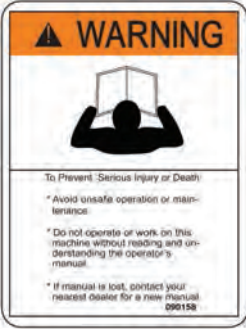

(Not all label locations shown)

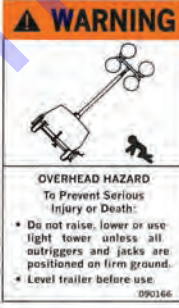

All Maxi-Lite II / Mine Spec / Rig Spec:	
A	<p>California Proposition 65 Warning Part No. 090179</p> 
B	<p>DANGER - Contacting Power Lines. Contacting electric power lines when elevating the light tower will result in death or serious injury. Always maintain a safe distance from power lines when elevating the tower. Part No. 090165</p> 
C	<p>DANGER - Ground Rod. Operating the machine without first installing the ground rod will result in death or serious injury. Always drive the ground rod into the earth and connect the ground wire to the grounding lug on the trailer before operating the machine. Part No. 090163</p> 
D	<p>DANGER - Contacting High Voltage Components. Contact with high voltage components within this compartment will result in death or serious injury. Do not enter electrical compartments when engine is running. Always close cover before operating the machine. Part No. 090162</p> 

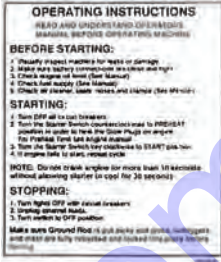

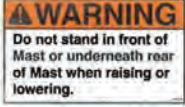

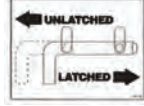









E	<p>DANGER - Contacting High Voltage Components. Contact with high voltage components will result in death or serious injury. Always read the instructions in the Operator's Manual before servicing high voltage electrical components. Part No. 090002</p> 
F	<p>WARNING - Check for overhead obstructions before raising or lowering mast. Part No.</p> 
G	<p>WARNING - Explosive Gases. Explosive gases could result in death or serious injury. Keep open flame and lighted materials away from battery. Part No. 090159</p> 
H	<p>WARNING - Standing under the light tower when it is being lowered could result in death or serious injury. Always stay clear of the light tower when the tower is being lowered. Part No. 101404</p> 
I	<p>WARNING - Excessive Towing Speed. To prevent serious injury, death or equipment damage, do not exceed 55 mph (88 km/h). Part No. 090160</p> 

J	<p>WARNING - Read Operator's Manual. Read and understand the Operator's Manual before operating this machine.</p> <p>Part No. 090158</p>	
K	<p>WARNING - Roll Over Hazard. Performing high speed sharp turns could cause trailer to roll over resulting in death or serious injury. Always slow to a safe speed when performing sharp turns.</p> <p>Part No. 090226</p>	
L	<p>Lifting Ring Rating - 3500 lbs (1588 kg)</p> <p>Part No. 104754</p>	
M	<p>WARNING - Automatic Engine Start. Engine may start unexpectedly. To avoid serious injury or death, always read instructions in LSC 2.0 Operator's Manual before servicing.</p> <p>Part No. 105939</p>	
N	<p>WARNING - Use Outriggers. Elevating light tower without deploying the outriggers could cause machine to tip over and result in death or serious injury. Always deploy the outriggers on a firm level surface and make sure machine is level before raising the tower.</p> <p>Part No. 090166</p>	

O	<p>Operating Instructions. Read and understand the Operator's Manual before operating this machine.</p> <p>Part No. 102909</p>	
<p>Specific to Vertical Towers:</p>		
P	<p>WARNING - You must lower the tower to the lowest position prior to moving the light tower trailer, or damage may occur. Hold the down switch for three (3) additional seconds after the tower appears to be down.</p> <p>Part No. 100247</p>	
<p>Specific to Laydown Towers:</p>		
Q	<p>WARNING - Do not stand in front of mast or underneath rear of mast when raising or lowering.</p> <p>Part No. 090003</p>	
R	<p>WARNING - Non-vertical tower can cause severe injury or death. Keep all persons clear before raising or lowering mast. Do not extend or retract mast unless latch is securely in place.</p> <p>Part No. 090164</p>	
S	<p>CAUTION - If winch is used in freezing or icy conditions, apply silicone to ratchet pawl and spacer. Refer to winch operator manual.</p> <p>Part No. 090474</p>	
T	<p>Mast Latch</p> <p>Part No. 090139</p>	

## Operation Icons

The following table contains operation icons that may be found on the unit, along with the meaning of each icon.

Icon	Meaning	Icon	Meaning
	On (Power)		Trailer Interior Light
	Off (Power)		Earth Ground
	Engine Stop		Raise Light Tower
	Engine Run		Lower Light Tower
	Engine Start		Engine Oil Drain
	Engine Preheat		Fluid Containment Drain
	Hourmeter		Engine Coolant Drain
	Worklight		

Discount-Equipment.com



# USING THE LIGHT TOWER

MAXI-LITE II / MINE SPEC / RIG SPEC

<b>OVERVIEW</b> .....	<b>3-2</b>
<b>WORK SITE CONSIDERATIONS</b> .....	<b>3-2</b>
<b>OVERHEAD CLEARANCE</b> .....	<b>3-2</b>
<b>GROUND CONDITIONS</b> .....	<b>3-2</b>
<b>WIND</b> .....	<b>3-2</b>
<b>LEVELING AND STABILIZING THE TRAILER</b> .....	<b>3-3</b>
<b>INSTALLING and USING THE GROUND ROD</b> .....	<b>3-5</b>
<b>ADJUSTING THE LIGHTS</b> .....	<b>3-6</b>
<b>RAISING AND LOWERING THE LIGHT TOWER</b> .....	<b>3-7</b>
<b>ENGINE OPERATION</b> .....	<b>3-10</b>
<b>PRE-START CHECKS</b> .....	<b>3-10</b>
<b>STARTING THE ENGINE</b> .....	<b>3-10</b>
<b>JUMP STARTING THE ENGINE</b> .....	<b>3-10</b>
<b>STOPPING THE ENGINE</b> .....	<b>3-11</b>
<b>AUTOMATIC ENGINE SHUTDOWN SYSTEMS</b> .....	<b>3-12</b>
<b>FUELING YOUR LIGHT TOWER</b> .....	<b>3-12</b>
<b>TURNING ON THE LIGHTS</b> .....	<b>3-13</b>
<b>SEQUENCED LIGHTING SYSTEM (SLS)</b> .....	<b>3-13</b>
<b>SHUTDOWN PROCEDURE</b> .....	<b>3-13</b>
<b>AUXILIARY AC OUTLET OPERATION</b> .....	<b>3-14</b>
<b>USING OTHER OPTIONAL EQUIPMENT</b> .....	<b>3-14</b>
<b>SAF-T-VISOR</b> .....	<b>3-14</b>

## OVERVIEW

Allmand light tower trailers are intended to be used for job site illumination and electrical power. The diesel engine drives a generator, which provides power for the light fixtures and the power outlets. When the lights are not in use, all of the generator power is available at the outlets. When all four lights are on, they consume approximately 4.5 to 5.5 kilowatts (kW) of power (depending on the rating of the light fixtures equipped on your light tower), leaving the remainder of the generator power for the outlets. The amount of power available depends on the generator with which your light tower is equipped.

Most controls for the light tower are accessed through the door on the left rear of the trailer. Access for inspection and maintenance of the engine, generator, and other components is through the side doors.

## WORK SITE CONSIDERATIONS

Prior to starting and operating the light tower, you must determine where to place it on the work site. The best possible light coverage and illumination is attained when the light tower is located on the same level as the work area to be illuminated. When placing the light tower trailer, consideration must be given to overhead clearance, ground conditions, and wind.

As the operator, it is your responsibility to ensure that the light tower trailer is properly positioned on the work site. Proper placement on the work site will provide for safe and stable operation of the light tower.

## OVERHEAD CLEARANCE

Before positioning the light tower trailer on the work site, make sure that there are no overhead obstructions where you intend to place the trailer. If the work site is in an enclosed area, such as a building, keep in mind that, when vertical and extended, the light tower mast requires a minimum of 36 feet (11 m) from ground level to the top of the light fixture.

Always keep well clear of any overhead power lines or buss bars.

### DANGER



Contact with overhead electrical wires will result in death or serious injury. Always maintain a minimum distance of 45 feet (14 m) from overhead wires to the light tower.

Keep well clear of any loose cables, ropes, or obstructions that could interfere with the light tower mast.

## GROUND CONDITIONS

You must place the light tower trailer on a firm, stable surface that will support the total weight of the trailer, as well as each of the five stabilizer jacks. Make sure that the surface where the light tower is to be positioned has enough area to allow full extension of all outriggers. We recommend that the trailer be positioned on a level surface, however, if it is necessary for the trailer to be positioned on a grade, do not exceed a grade of 5% (2.9° incline) in any direction. Grades greater than 5% may exceed the extension limits of the stabilizer jacks, preventing contact of one or more of the jacks with the ground.

### WARNING

Raising the light tower without properly positioning the outriggers and stabilizer jacks first could cause machine rollover, resulting in death or serious injury. Always deploy the outriggers and stabilizer jacks on a firm, level, and stable surface before raising the light tower.

## WIND

When the light tower is vertical and extended, wind can exert a powerful force on the light tower trailer. When you position the trailer on the work site, be aware of ground obstructions such as buildings, structures, or trees that may direct wind toward the light tower or cause buffeting around the light tower.

With the outriggers and stabilizer jacks properly deployed on stable ground, and the light tower trailer properly leveled, the light tower is designed to withstand sustained winds of 53 mph (85 km/h) without the danger of rollover.

**! WARNING****ROLLOVER HAZARD**

Operating the light tower mast fully raised in winds exceeding 53 mph (85 km/h) can cause machine rollover, resulting in death or serious injury. Always lower the light tower when winds are expected to exceed 53 mph (85 km/h).

**LEVELING AND STABILIZING THE TRAILER**

After you determine the appropriate placement of the light tower trailer at the work site, you must make sure that the trailer is level and stable prior to starting and operating the light tower.

**Chocking the Wheels**

After you position the light tower, you must place the wheel chocks on both sides of the wheels to hold the trailer in place while the outriggers are being deployed.

**To chock the wheels:**

- 1 Make sure that the trailer is properly positioned on the work site as described in "WORK SITE CONSIDERATIONS" on page 3-2.
- 2 Place a wheel chock on one side of each wheel. If the trailer is positioned on a slight incline, place a wheel chock on the downhill side of each wheel first.
- 3 Place a wheel chock on the other side of each wheel.

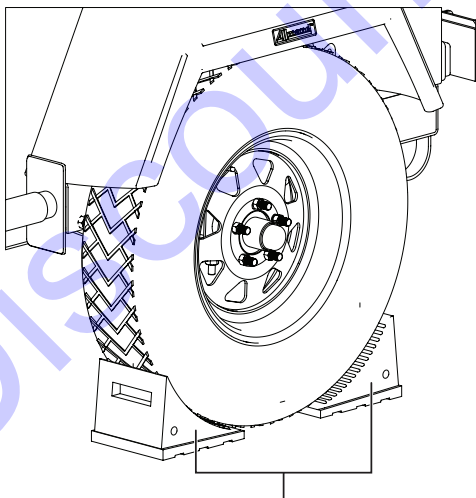

Wheel Chocks

**! WARNING****ROLLOVER HAZARD**

Do not set this trailer up on non-level or unstable ground. Only set up on a smooth, flat, level surface. Always level the light tower trailer before raising the light tower.

**Wheel Chocks and Brackets (Optional)**

Two pairs of wheel chocks, with storage brackets, are available from Allmand as an option. These are located on the front of the machine.

**To remove wheel chocks from the brackets:**

- 1 Release the rubber strap from over the top of the two wheel chocks in the bracket.
- 2 Remove the wheel chocks from the bracket with an upward and slightly forward motion, to clear the louvers immediately above the bracket.

**To install the wheel chocks into the brackets:**

- 1 Hold the wheel chocks by the hand hole, with the curved surface toward you. Tilt the upper portion of the chocks away from the trailer, to clear the louvers, as you insert the chocks into the bracket.
- 2 When both wheel chocks are inserted into the bracket, pull the rubber strap over the top of both chocks and hook it into the hole in the bracket to secure them.

Wheel chocks (four) are stored on the front of the trailer, two on either side of the tower.

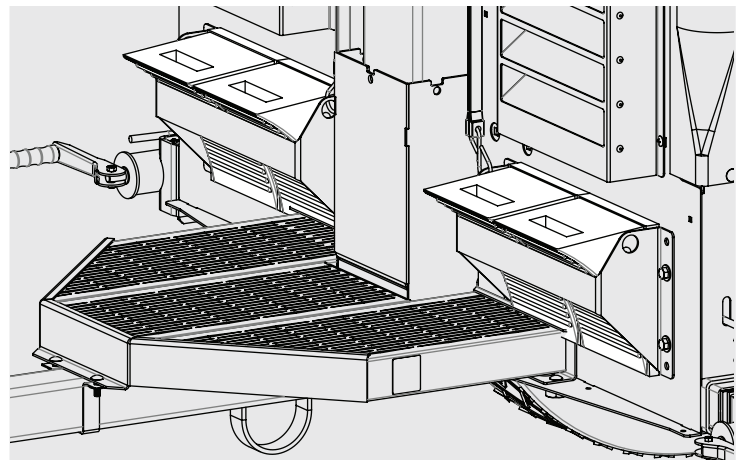

**To level and stabilize the trailer:**

- 1 Position the unit on a suitable site. See "WORK SITE CONSIDERATIONS" on page 3-2.
- 2 Block both sides of each wheel with wheel chocks.

**! WARNING****ROLLOVER HAZARD**

All stabilizer jacks must be in firm contact with a flat, level, solid ground surface.

- 3 Extend the outriggers and lock them into place.

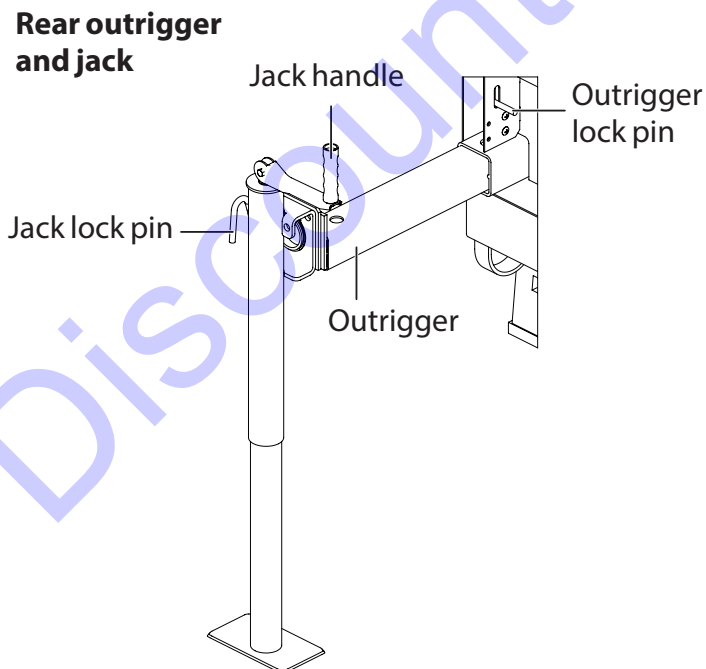
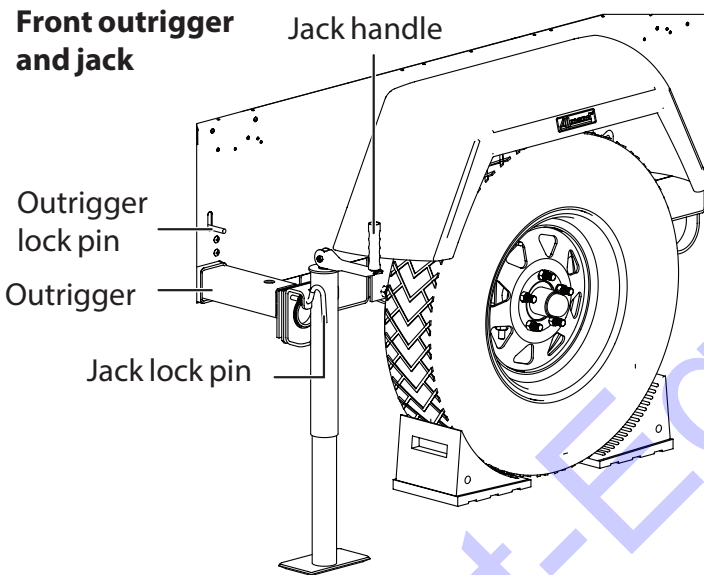

- 4 Pull out the jack lock pin, then rotate the stabilizer jacks into position (perpendicular to the ground). Release the lock pin to lock them into place.
- 5 Adjust each stabilizer jack and the tongue jack to achieve proper leveling. Turning the handles clockwise will raise the jacks and counterclockwise will lower the jacks.

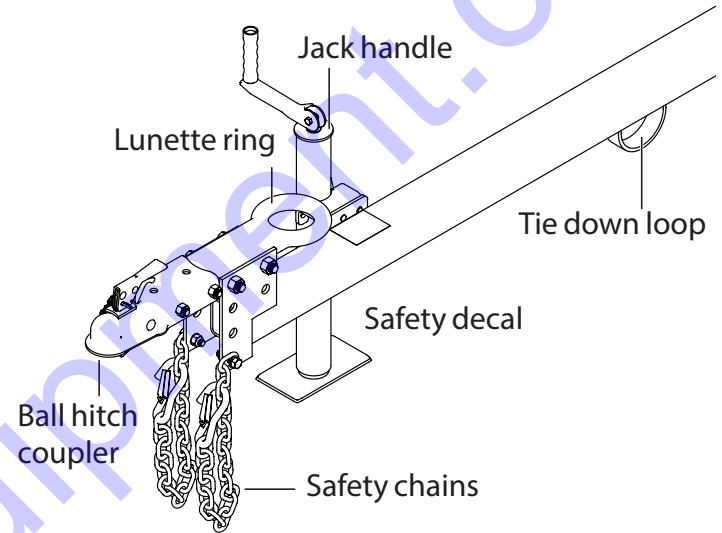



## INSTALLING and USING THE GROUND ROD

The ground rod is a safety device that reduces the chance of personal injury from stray electrical currents. Therefore, Allmand recommends using the ground rod whenever the light tower is in use. It is the user's responsibility to determine the requirements and/or applicability of local, state, or national electrical code, which governs the use of the ground rod.

### To install the ground rod:

- 1 Drive the ground rod (provided) fully into the ground using a heavy hammer, such as a single jack.
- 2 Attach the grounding cable (provided) to the rod and then to the grounding lug on the trailer. See "Maxi-Lite II Laydown Tower- Front view" on page 3 for the location of the grounding lug. Make sure that the cable connections are tight.

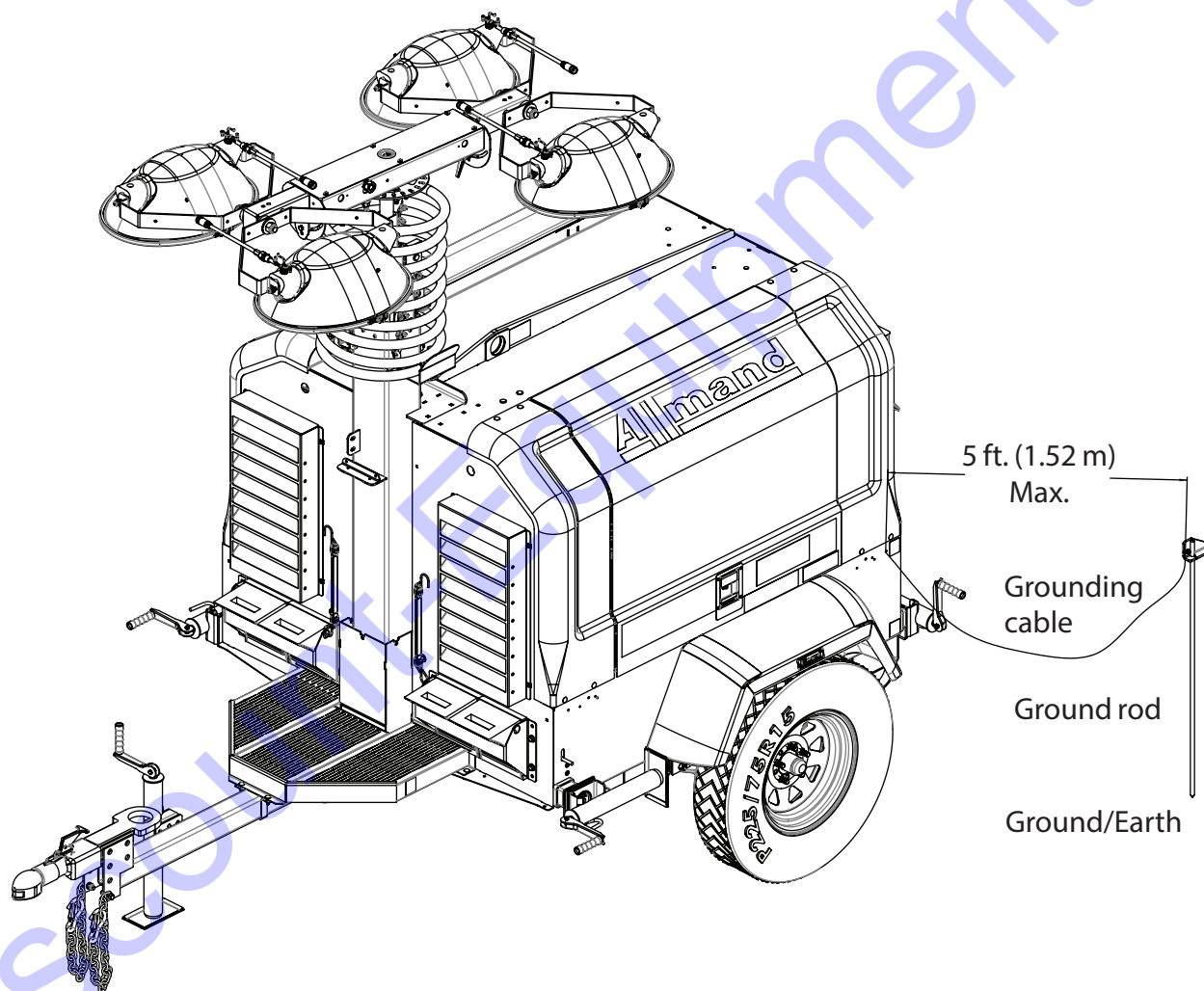

## ADJUSTING THE LIGHTS - VERTICAL TOWER

The light bar and light fixtures must be adjusted to the work angle you want prior to raising the tower.

### WARNING

#### BURN HAZARD

The light fixtures become extremely hot during use. Always use caution and wear heat-resistant gloves when handling the lights or allow the lights to cool down before handling.

## ROTATING THE LIGHTS TO THE DESIRED ANGLE

**To adjust the light bar at the work site:**

- 1 Release the light bar park pin by pulling the ring out and turning it 90° so that the pin remains in the retracted position.

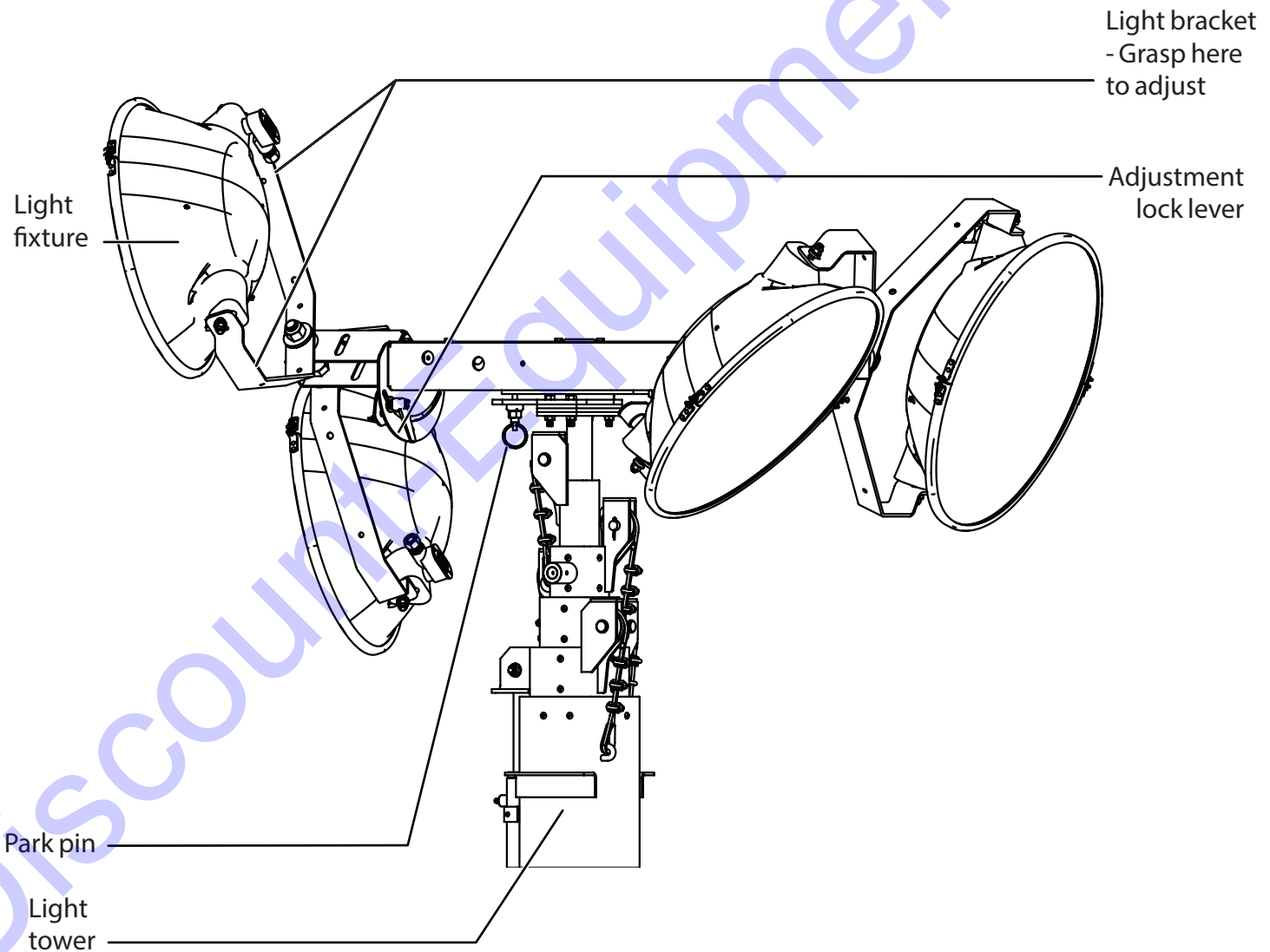

- 2 With the park pin released, the light bar can be manually rotated. It has enough built-in resistance that the bar will stay in position after the operator has directed the lights on the work zone.

If the light bar rotates too easily or does not stay in position, remove the cap plug from the center of the light bar cover and tighten the nut to achieve the proper resistance, then replace the cap plug.

- 3** To adjust each light fixture, manually swivel each fixture at its base into the working position you want. There are two adjustments per light. The fixture and bracket assembly rotates on the pivot point where it attaches to the bar and the light fixture rotates within the bracket.

### NOTICE

Note that there are two adjustments for each individual light: you can rotate the bracket or you can rotate the light itself within the bracket. All necessary adjustments need to be made before raising the tower.

## POSITIONING THE TOWER ARMS

With the light tower fully lowered and the lights off, the tower arms and light fixtures can be manually rotated into the position you want.

Each arm of the light tower needs to be independently rotated while the tower is down. On four light models, the light bar will rotate 45° in either direction. On six light models, the light bar will rotate 90° in either direction.

### To rotate the tower arms on four light models:

There is an adjustment lock lever on each arm. To loosen or tighten, the lock lever can be pulled out to allow it to “ratchet.”

- 1 Loosen the adjustment lock lever on each arm.
- 2 Rotate the arm to either side of center to the desired angle (up to 45°).
- 3 Tighten the adjustment lock lever to hold the light bar in position.

### To rotate the tower arms on six light models:

- 1 Release the tower arm park pin by pulling the ring out and turning it 90° so that the pin stays in the retracted position.
- 2 Loosen the adjustment lock lever (one on each arm).
- 3 Rotate the arm to either side of center to the desired angle (up to 90°).
- 4 Secure the arm in the desired position by:
  - Setting the tower arm lock pin by turning the ring 90° and letting the pin spring back into one of the indexed slots.
  - Tightening the adjustment lock lever.

## ADJUSTING THE LIGHTS - LAYDOWN TOWER

The light bar and light fixtures must be adjusted to the work angle you want prior to raising the tower.

### WARNING

#### BURN HAZARD

The light fixtures become extremely hot during use. Always use caution and wear heat-resistant gloves when handling the lights or allow the lights to cool down before handling.

## ROTATING THE LIGHTS TO THE DESIRED ANGLE

### To adjust the light bar at the work site:

- 1 Rotate the light fixture up or down in its bracket to adjust the vertical angle of the light.
- 2 Rotate the light fixture and bracket left or right to adjust the horizontal angle of the light.
- 3 The entire light tower can be rotated to the left or right to place the light where it is needed.

## RAISING AND LOWERING THE LIGHT TOWER - VERTICAL TOWER

Before operating the tower lights, review “[SAFETY PRECAUTIONS](#)” on page 2-2. The light tower is raised and lowered by a hydraulic pump.

### WARNING

#### ROLLOVER HAZARD

Before raising, lowering, or operating the tower lights, the trailer must be set up, properly leveled and stabilized, and the ground rod installed. Refer to “[WORK SITE CONSIDERATIONS](#)” section on page 3-2.

### WARNING

#### CRUSH HAZARD

Allow adequate clearance around and above the trailer when raising or lowering the light tower. Ensure that there are no obstructions or persons near the light tower when raising or lowering it.

**NOTICE**

The hydraulically actuated light tower uses 12VDC battery power to operate. The light tower may be raised and lowered, as needed, without the engine running.

**NOTICE**

Before raising the light tower, visually inspect the equipment for damage or wear, and repair or replace components as required. Never operate the light tower with damaged or malfunctioning components.

Before raising the light tower, adjust the tower lights to the work position you want.

**To raise the hydraulic tower:**

- 1 If required, start the engine. See “[STARTING THE ENGINE](#)” on page 3-8 for starting procedure.
- 2 Turn the lights off. Refer to “[TURNING ON THE LIGHTS](#)”.
- 3 Press the light tower hydraulic lift switch **UP** to raise the light tower to the desired height.

**To lower the hydraulic tower:**

- 1 If required, start the engine. Refer to your *Engine Operator's Manual* for starting procedure.
- 2 Turn the lights off. Refer to “[TURNING ON THE LIGHTS](#)”.
- 3 Press the tower light hydraulic lift switch **DOWN** to lower the light tower to the desired height or to the full down position.
- 4 When the tower reaches the bottom, hold the switch for an additional three seconds to make sure that the tower is at its lowest possible position.
- 5 If necessary, stop the engine.

**RAISING AND LOWERING THE LIGHT TOWER - LAYDOWN TOWER**

Before operating the tower lights, review “[SAFETY PRECAUTIONS](#)” on page 2-2.

The manual winch tower can be raised and extended by operating two hand crank winches. One winch, mounted with the handle extending through the side of the trailer frame, raises and lowers the mast from the horizontal towing position to the vertical position and back. The second winch mounted on the tower extends

and retracts the telescopic sections.

**WARNING****ROLLOVER HAZARD**

Before raising, lowering, or operating the tower lights, the trailer must be set up, properly leveled and stabilized, and the ground rod installed. Refer to “[WORK SITE CONSIDERATIONS](#)” section on page 3-2.

**WARNING****CRUSH HAZARD**

Allow adequate clearance around and above the trailer when raising or lowering the light tower. Ensure that there are no obstructions or persons near the light tower when raising or lowering it.

**NOTICE**

Before raising the light tower, visually inspect the equipment for damage or wear, and repair or replace components as required. Never operate the light tower with damaged or malfunctioning components.

Before raising the light tower, adjust the tower lights to the work position you want. Refer to “[ADJUSTING THE LIGHTS - LAYDOWN TOWER](#)”.

**To raise the laydown tower:**

- 1 Turn the lights off. Refer to “[TURNING ON THE LIGHTS](#)”.
- 2 Release the pin that secures the mast to the rear mast support.
- 3 Operate the hand crank on the right side of the trailer to raise the mast from horizontal to vertical.
- 4 Engage the automatic spring lock pin.
- 5 Operate the hand crank winch on the tower clockwise to raise the lights vertically.
- 6 To rotate lights, turn the upper black knob counterclockwise and turn the tower with the handles. Retighten knob.

**To lower the laydown tower:**

- 1 Turn the lights off. Refer to “[TURNING ON THE LIGHTS](#)”.
- 2 Loosen the upper black knob and rotate tower until handles are parallel with the front of the trailer and retighten knob.

- 3 Operate the upper hand crank winch counterclockwise to lower the lights to the lowest vertical position.

**! WARNING**

**TIP HAZARD**

Lowering the light tower to the horizontal position before lowering the mast to the lowest vertical position could cause the trailer to tip over, resulting in death or serious injury. Always use the hand crank winch on the light tower to lower the tower vertically first, before using the winch on the side of the trailer to lower the light tower to the horizontal towing position.

- 4 Operate the lower hand crank winch on the side of the trailer clockwise to take up any slack in the cable.
- 5 Disengage the automatic spring lock.
- 6 Operate the lower hand crank on the side of the trailer counterclockwise to lower the mast into the horizontal towing position.
- 7 Secure the light cords into hook on the rear tower support.
- 8 Secure the rear support release pin, locking the mast to the rear tower support for towing.

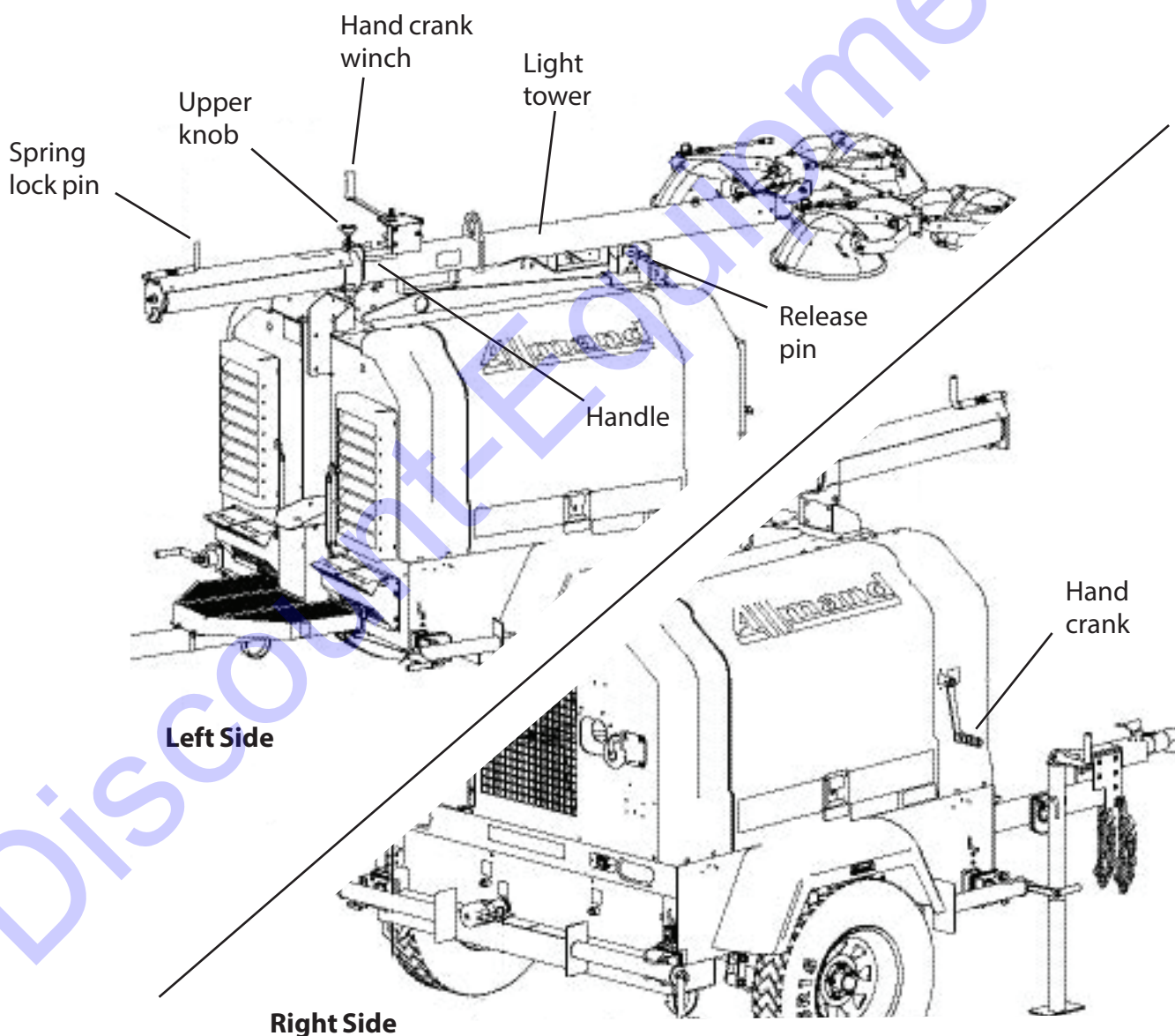

## ENGINE OPERATION

Before starting the engine or operating the light tower, review “SAFETY PRECAUTIONS” on page 2-2.

The **Maxi-Lite II** light tower is powered by a diesel engine and generator unit.

### PRE-START CHECKS

- 1 Check the engine oil and add oil if required. Fill the engine with the proper grade of lubricating oil.
- 2 Check the fuel level and add diesel fuel as required.
- 3 Make sure that the air cleaner is firmly attached and that air cleaner seals and hose clamps are properly secured. The air cleaner element should be checked, and replaced if necessary.

### STARTING THE ENGINE

#### To start the engine:

- 1 For LSC 2.0, refer to the LSC 2.0 Operator’s Manual.
- 2 Turn the key to the left to the PREHEAT position.
- 3 Wait 10 seconds for glow plug to heat.
- 4 Turn the key all the way to the right to the START position, until the engine starts.

If the engine has run out of fuel, refill the fuel tank, then proceed with the starting procedure.

#### NOTICE - Don’t burn out the starter

Do not operate the starter for more than 10 seconds without allowing 30 seconds to pass between starting attempts. Possible starter damage could result from excessive heat caused by cranking the engine too long.

#### NOTICE - Don’t double-start

If the engine develops sufficient speed to disengage the starter but does not keep running (a false start), the engine must be allowed to come to a complete stop before you try to restart it.

If the starter is engaged while the flywheel is rotating, the starter pinion and flywheel ring gear may clash. This could damage to the starter or flywheel ring gear.

## JUMP STARTING THE ENGINE

In the event of a low or exhausted battery, the engine on your light tower can be jump started.

#### To jump start the engine:

- 1 Open the left side panel door to gain access to the battery.
- 2 Connect jumper cables to the battery terminals on the battery of the starting vehicle, red to the positive terminal and black to the negative terminal.

#### CAUTION

Exercise extreme caution not to touch the ends of the jumper cables together when they are connected to a battery. Touching the ends of the cables together can cause a fire or possibly an explosion.

- 3 Connect the jumper cables to the battery in your trailer, red to the positive terminal and black to the negative terminal.
- 4 Start the starting vehicle.
- 5 Attempt to start the engine on the light trailer.
- 6 When the engine on the light trailer starts, wait a bit, then remove the jumper cables from the battery in the trailer, then from the battery in the starting vehicle.

## STOPPING THE ENGINE

### To stop the engine:

- 1 For LSC 2.0, refer to the LSC 2.0 Operator's Manual.
- 2 Turn the key to the STOP position to shut down the engine.

## EMERGENCY STOP (E-STOP) PLUNGER

The Emergency Stop, or "E-Stop" plunger is a kill switch for the entire system. In an emergency, the E-Stop plunger can be pressed to completely shut down the operation of the Mine Spec II trailer.

When the E-Stop plunger is pressed the engine stops, the lights are turned off, and the tower remains up. Pulling the E-Stop plunger out resets the system and the engine can be restarted.

## BATTERY DISCONNECT

A lockable switch that renders the trailer inoperable. Can be used to prevent tampering and vandalism when the trailer is left overnight or for extended periods of time.

## CHALWYN VALVE (ENGINE AIR INTAKE SHUTDOWN VALVE) - (OPTIONAL ON MAXI-LITE II, STANDARD ON MINE SPEC / RIG SPEC)

The Engine Air Intake Shutdown Valve is intended to prevent the Diesel engine from going into an over-speed condition in the event that flammable gas or vapor is present at the engine air intake. Should an over-speed condition occur, the Engine Air Intake Shutdown Valve automatically closes, preventing air from getting into the cylinders, thereby stopping the engine.

The Engine Air Intake Shutdown Valve should be tested daily. To test, open the left side cover door and locate the red switch. With the engine running, switch to the OFF position. The engine should shut down. If the engine does not shut down, the valve is not functioning properly. In that event, shut down the engine, tag the machine "Do Not Operate," and notify your service or maintenance department.

## AUTOMATIC ENGINE SHUTDOWN SYSTEMS

The engine is equipped with several automatic engine shutdown systems. These systems are in place to prevent excessive engine damage in the event of a low oil or overheat condition. For additional information, refer to your *Engine Operator's Manual*.

### LOW OIL PRESSURE SHUTOFF

If a low oil pressure condition occurs, the oil pressure sending unit breaks the circuit between the battery and the fuel solenoid, which shuts off the fuel.

### HIGH COOLANT TEMPERATURE SHUTOFF

If a high coolant temperature condition occurs, the temperature sending unit breaks the circuit between the battery and the fuel solenoid, which shuts off the fuel.

## FUELING YOUR LIGHT TOWER

Open either side panel. The fuel tank is actually two tanks, one on each side, both with filler caps. The tanks are connected, so filling either side will fill the entire tank. The trailer holds 100 gallons (378.5 L).

### NOTICE

Pressurized fueling is NOT ALLOWED.

The diesel fuel used for the engine must be clean and free of dirt, contaminants and water.

In North America, diesel fuels that meet ASTM D975 for Ultra Low Sulfur Diesel (ULSD) are required to be used. ULSD has a maximum sulfur content of 15 Parts Per Million (PPM) or 15 mg/kg. Diesel fuel may be No. 1-D or No. 2-D.

Refer to the *Engine Operator's Manual* for more detailed fuel requirements.

### LOW FUEL STROBE LIGHT (MINE SPEC / RIG SPEC ONLY)

All Mine Spec and Rig Spec machines are equipped with low fuel level strobe lights. When the fuel level in the fuel tanks is at approximately 1/8 full, the strobe light will begin blinking to indicate the low fuel level.



## TURNING ON THE LIGHTS

The tower light control panel contains the breaker switches that control the trailer lights (one switch per light).

The four or six light fixtures are controlled and protected by four or six breaker switches located on the light control panel. For additional information, see “[CONTROL PANEL OVERVIEW](#)” on page 1-10. The switches work just like a regular circuit breaker in your home. Normal settings are ON and OFF. If a breaker trips, it is in the “center” position, and you have to turn it all the way OFF and then back ON again.

### SEQUENCED LIGHTING SYSTEM (SLS)

The lights are automatically controlled by the sequenced lighting system (SLS). Simply leave the breaker switches in the ON position for automatic light control. However, the breaker switches may be turned off for individual light control.

#### To turn the lights on:

Start the engine and the lights will sequence on automatically.

Turn one or more light breaker switches to the OFF position for individual light control.

#### To turn the lights off:

Turn the engine off, and the lights will shut down automatically.

The lights will turn off a fraction of a second ahead of engine shutdown; this prevents capacitor damage.

## SHUTDOWN PROCEDURE

#### To shut down for a short period of time:

- 1 With the lights off, lower the light tower to the full down position.
- 2 Turn the engine off.

#### To shut down for a long period, or to prepare for trailering:

- When shutting down the light tower for long periods of time or when preparing to trailer, refer to “[PREPARING FOR TRAILERING - SHUTDOWN](#)” on page 4-3.

## AUXILIARY AC OUTLET OPERATION

Depending on your model options, the 240VAC single phase rear outlet panel is equipped with four 240/208VAC outlets and two 120VAC GFCI outlets. These can be used for powering accessories.

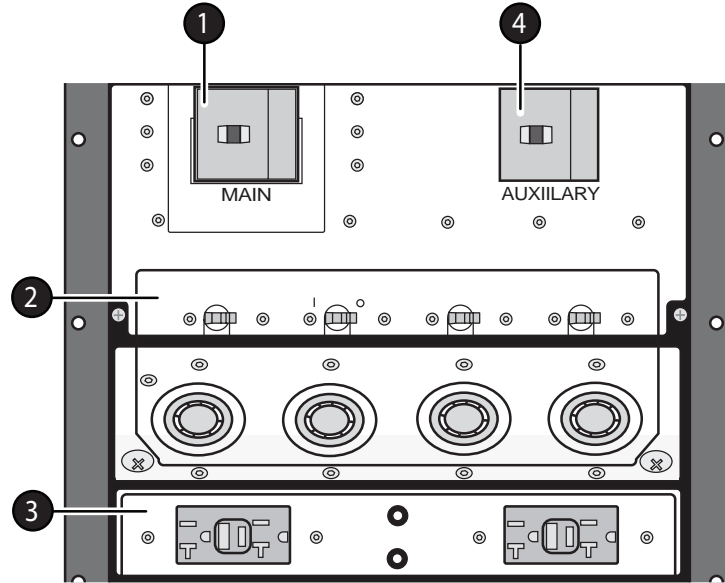

<b>1</b>	<b>Main breaker</b>	Turns the whole panel on or off.
<b>2</b>	<b>240/208V breakers and outlets</b>	Outlets provide 240V/208V power. Breakers directly above turn the outlets on and off.
<b>3</b>	<b>120V GFCI breakers</b>	Outlets provide 120V power, protected by GFCI (Ground fault circuit interrupter). Two reset buttons are located between the outlets.
<b>4</b>	<b>Auxiliary breaker</b>	Turns the 50A outlet on the other side of the trailer on or off.

The 240VAC outlet is protected by a 30A circuit breaker.

The 120VAC GFCI outlets are each protected by a 20A push button-type circuit breaker.

The main circuit breaker is a 90A DPST circuit breaker.

### If any of the outlet circuit breakers trip:

- 1 Remove the load from the outlets.
- 2 Turn off the tower lights (if they are on).
- 3 Correct the excessive load problem.
- 4 Wait 10 minutes to let the generator cool down, then reconnect the load and resume work.

## USING OTHER OPTIONAL EQUIPMENT

### SAF-T-VISOR

#### To install the Saf-T-Visor:

- 1 Turn off the lights and shut off the engine. Allow the bulbs and fixtures to cool.
- 2 Lower the light tower to the full down position.
- 3 Loosen the lens channel screws to allow the removal of the lens channel.
- 4 Remove the silicone gasket and lens.
- 5 Clean the reflector and lens.
- 6 Install the silicone gasket and lens (replace if damaged).
- 7 Place the Saf-T-Visor in the desired location on the lamp.
  - a. If the lamp is in a horizontal orientation, the Saf-T-Visor can be placed on either the top or bottom of the lamp.
  - b. If the lamp is in a vertical orientation, the Saf-T-Visor can be placed on either the left or right side of the lamp.
- 8 Once the Saf-T-Visor is placed on the lamp, install the lens channel and screws.
  - a. The outer edge of the Saf-T-Visor should be positioned between the lens channel and the silicone gasket.
- 9 Install the J-hooks and screws on the Saf-T-Visor.
  - a. The J-hooks should be placed around the lens channel on the back of the lamp, with the screws on the front of the lamp (near the lens).



# MOVING THE LIGHT TOWER

MAXI-LITE II / MINE SPEC / RIG SPEC

<b>PREPARING THE LIGHT TOWER FOR DELIVERY</b> .....	<b>4-2</b>
<b>CHECKLIST</b> .....	<b>4-2</b>
<b>BEFORE TRAILERING OR TRANSPORTING</b> .....	<b>4-3</b>
<b>PREPARING FOR TRAILERING - SHUTDOWN</b> .....	<b>4-3</b>
<b>PREPARING FOR TRAILERING - STOWING THE LIGHTS</b> .	<b>4-4</b>
<b>TRAILERING OR TOWING THE LIGHT TOWER</b> .....	<b>4-5</b>
<b>TOWING VEHICLE AND HITCH CONSIDERATIONS</b> .....	<b>4-5</b>
<b>LIFTING THE LIGHT TOWER</b> .....	<b>4-7</b>
<b>TRANSPORTING ON A TRAILER</b> .....	<b>4-8</b>

Discount-Equipment.com



## PREPARING THE LIGHT TOWER FOR DELIVERY

The light tower requires service as well as proper operation in order to provide the performance and safety it has been designed for. Never deliver or put the machine into service with known defects or missing instructions or decals. Always instruct the customer in proper operation and safety procedures as described in this *Operator's Manual*. Always provide the manual with the equipment to ensure proper and safe operation.

### **DANGER**

#### **ELECTROCUTION HAZARD**

Do not operate the light tower if the insulation on the electrical cord or other electrical wiring is cut or worn, or if bare wires are exposed. Repair or replace damaged wiring before starting the engine.

### **WARNING**

#### **UNSAFE OPERATION HAZARD**

Never permit anyone to install or operate the equipment without proper training.

### **NOTICE**

See the appropriate section in the *Engine Operator's Manual* and the *Generator Operator's Manual* for additional pre-operation checks.

## CHECKLIST

- Visually inspect the equipment to ensure that all instructions and decals are in place and are legible.
- Inspect the light tower locking bar latch assembly, which locks the light tower in the vertical position, for proper operation.

- Check the hitch assembly and safety chains to make sure that they are in good condition.
- Check the outriggers and jacks to make sure that they operate properly.
- Inspect the light assemblies for damage and test for proper operation.
- Inspect the electrical wiring for signs of damage or excessive wear.
- Check the ground rod cable and the grounding lug. Make sure that they are clean, undamaged, and functional.
- Inspect the tires to ensure that they are in good condition and are properly inflated.
- Check the engine oil, fuel, engine coolant levels, and hydraulic fluid levels, if so equipped.
- Check to make sure that this *Operator's Manual*, the *Engine Operator's Manual*, and the *Generator Operator's Manual* are with the equipment.
- Install the plug into the Fluid Containment System.
- Inspect the machine physically for damage, and repair if necessary.

After completing the pre-operation checklist, operate the tower through a complete operation cycle, following the operating instructions in the *Operator's Manual*.

## **ALWAYS READ AND UNDERSTAND THE INSTRUCTIONS FIRST**

Before trailering, transporting, or lifting your light tower, read the chapter on **SAFETY** on page 2-1.

## BEFORE TRAILERING OR TRANSPORTING

- Lower the light tower and shut down the tower lights and the engine. See "PREPARING FOR TRAILERING - SHUTDOWN" below.
- Visually inspect the trailer and equipment for damage. Repair or replace any components as needed, prior to moving the trailer.
- Check the trailer lights for proper operation.
- Inspect the tires to ensure that they are in good condition and are properly inflated.
- Inspect the trailer springs and undercarriage for damage or loose parts.
- Check the hitch assembly and safety chains.
- Check the outriggers and jacks to make sure that they are properly stowed.
- Make sure that the ground rod and cable are properly stowed.
- Clean any spills from inside the trailer bilge area around the outside of the trailer that may have occurred during operation.
- Make sure that all compartment doors are closed and securely locked.

## PREPARING FOR TRAILERING - SHUTDOWN

### To prepare the light tower for trailering:

- 1 With the tower lights off, lower the light tower to the full DOWN position. Refer to "" on page 3-7.
- 2 Turn the engine off. Refer to your *Engine Operator's Manual* for stopping procedure.

### NOTICE

See appropriate section of the *Engine Operators Manual* and *Generator Operator's Manual* for additional post-operation and shutdown procedures.

- 3 Adjust the light bar and light fixtures for trailering; see "PREPARING FOR TRAILERING - STOWING THE TOWER LIGHTS" below.

### NOTICE

Visually inspect the light mounting brackets and hardware for loose fasteners or damaged brackets. Repair any problems before trailering.

- 4 Secure the light cords into the hook on the rear mast support.
- 5 Disconnect the ground rod cable from the ground lug.
- 6 Remove the ground rod from the earth and clean and secure the ground rod and cable in the trailer.
- 7 Close, secure, and lock all compartment doors.
- 8 Raise all five stabilizer jacks and rotate into trailering position (parallel with the outrigger bar).
- 9 Retract all four outrigger bars and secure them in the stowed position with the latch pin.

### NOTICE

Before transporting, be sure that each outrigger jack is securely latched in the transport position by installing the outrigger lock pins.

## PREPARING FOR TRAILERING - STOWING THE LIGHTS

The light bar and fixtures must be stowed before trailering or transporting.

### WARNING

#### BURN HAZARD

The light fixtures become extremely hot during use. Always use caution and heat-resistant gloves when handling the lights or allow the lights to sufficiently cool down before handling.

#### To stow the tower lights for trailering:

- 1 Make sure that all lights are off and tower is lowered to the full down position.
- 2 Release the light bar park pin by pulling the ring and turning it 90 degrees so that the pin remains in the retracted position.
- 3 Rotate the light bar into the trailering / transport park position (in line with trailer) and engage the park pin by twisting the park pin ring until the plunger is released and the pin engages and locks into the hole in the light bar.
- 4 Reposition the light fixtures for trailering / transport by pulling them down into the lowest position and face the fixtures toward the center of the trailer.



## TRAILERING OR TOWING THE LIGHT TOWER

Before trailering or towing the light tower trailer, read “BEFORE TRAILERING OR TRANSPORTING” on page 4-3 and read the chapter on SAFETY on page 2-1

### CAUTION

Maximum highway speed is 60 mph (97 km/h) and the maximum off-highway speed is 20 mph (32 km/h). Do not exceed these limits or damage to the light tower may occur.

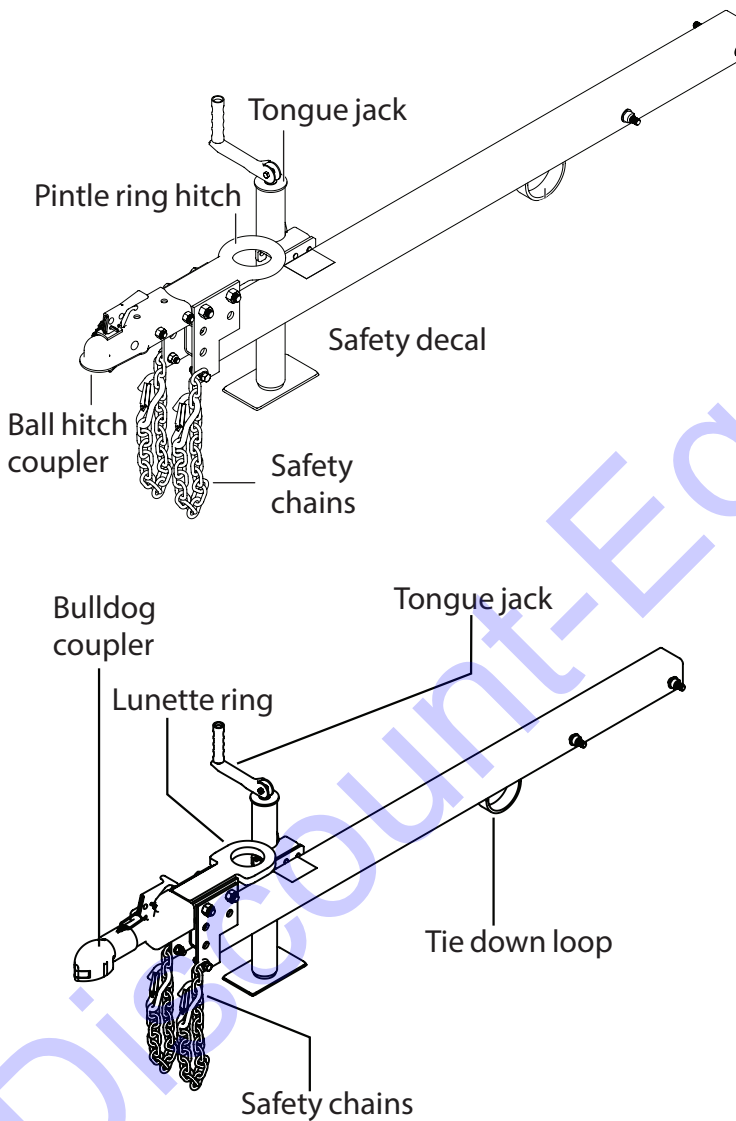

## TOWING VEHICLE AND HITCH CONSIDERATIONS

The towing vehicle must be able to safely pull the full trailer load.

### CAUTION

Never pull a trailer load that exceeds the vehicle’s towing capacity. You risk losing control of the trailer and vehicle.

Before trailering, always check your vehicle owner’s manual for the maximum towing/trailering load and gross vehicle weight specifications that include the fully loaded trailer.

The vehicle must be equipped with a towing hitch that can safely handle the trailering load and tongue weight of the trailer.

### WARNING

#### CONTROL HAZARD

A vehicle hitch that is underrated or improperly installed can lead to loss of control of the trailer and/or vehicle. Never use a hitch size or rating that does not match or exceed the trailer coupler specifications.

## CONNECTING THE TRAILER HITCH COUPLER AND LIGHTS

The trailer is normally equipped with a combination trailer coupler for a 2-inch ball hitch and a 3-inch lunette ring for a pintle hitch. It may be equipped with the optional bulldog hitch.

If you are using the standard hitch, the trailer coupler may be reversed to use either the ball or lunette hitch coupler. To reverse the coupler, remove the two bolts securing the hitch to the hitch bracket and reposition the coupler as needed.

### WARNING

#### CONTROL HAZARD

Make sure that the coupler bolts are securely tightened before trailering the light tower.

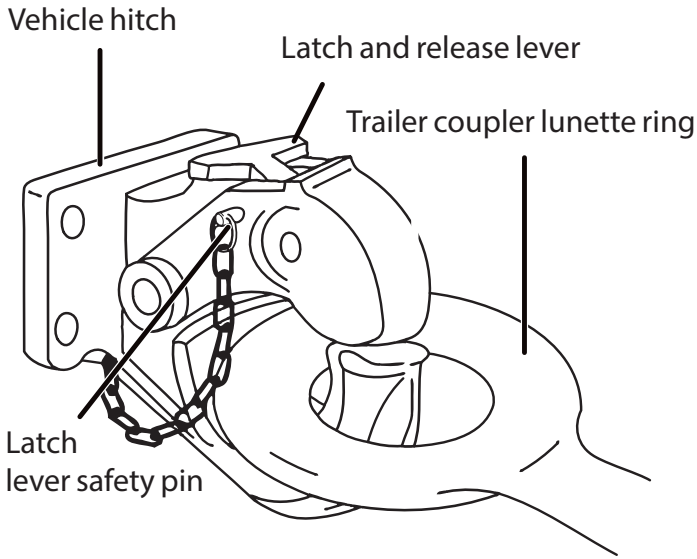

**Typical Lunette Ring Pintle-Type Hitch and Coupler**

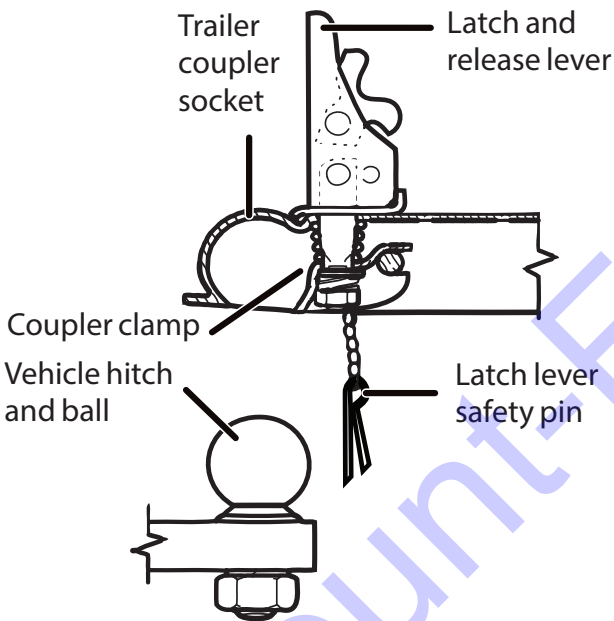

**Typical Ball-Type Hitch and Coupler**

The trailer's safety chains prevent the trailer from completely detaching from the towing vehicle when underway.

<b>NOTICE</b>
Safety chains must be rated at the same or greater weight capacity as the trailer's GVWR.

Before trailering, read "BEFORE TRAILERING OR TRANSPORTING" on page 4-3.

**To connect the light tower to the tow vehicle:**

- 1 Connect the tow vehicle hitch to the trailer coupler. Make sure that the coupler is securely attached to the tow vehicle's hitch.
- 2 Connect the safety chains to the vehicle's hitch frame and crisscross the chains under the trailer tongue to prevent it from dropping to the road if the trailer separates from the hitch ball. Rig the chains as tightly as possible, with enough slack to permit free turning.



**WARNING****CONTROL HAZARD**

Attach the safety chains properly and securely between the towing vehicle and trailer before trailering. Never let the chains drag on the ground when trailering.

- 3 Connect the light connector from the vehicle harness to the trailer harness.

Make sure that there is adequate slack in the wiring harness to prevent binding or disconnection when turning.

**NOTICE**

Do not allow excessive harness slack or the wiring harness can be damaged from scraping the ground.

- 4 Before trailering, check all lights for proper operation.

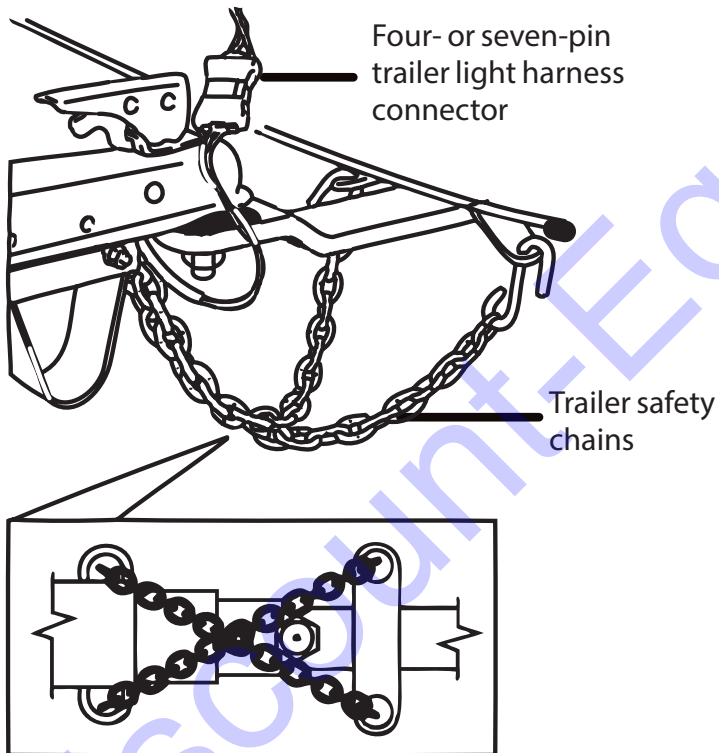
**LIFTING THE LIGHT TOWER**

The fully loaded light tower and trailer weighs approximately 3,500 lbs. (1,588 kg) with four fixtures. The Maxi-Lite II light tower is equipped with bottom forklift pockets and a lifting eye for lifting or hoisting. Forklift blades must be at least 60" in length to lift the trailer.

**WARNING****ROLLOVER HAZARD**

Before lifting, lower the light tower and shut down the tower lights and the engine. Refer to "PREPARING FOR TRAILERING - SHUTDOWN" on page 4-3.

**WARNING****CRUSH HAZARDS**

Always make sure that the lifting device you are using is in good condition and is rated for the maximum capacity of the task to safely lift the light tower trailer.

Always get assistance when using a forklift, crane, or hoist when loading or unloading.

Only use the lifting eye on the lifting bar to lift or hoist the unit with a hoist or crane.

Only use shackles or a locking-type hook when lifting.

Do not stand or walk under the unit when lifted. Keep others away from the unit when lifted.

Only lift one light tower at a time.

## TRANSPORTING ON A TRAILER

When transporting the light tower on a truck or trailer, always secure the unit using properly rated tie-down chains or straps to connect the trailer frame to the

towing trailer. There are four tie-down rings under the trailer (in front of and behind the axles on both sides of the trailer). **The operator of the towing vehicle is responsible for securing the load properly.**

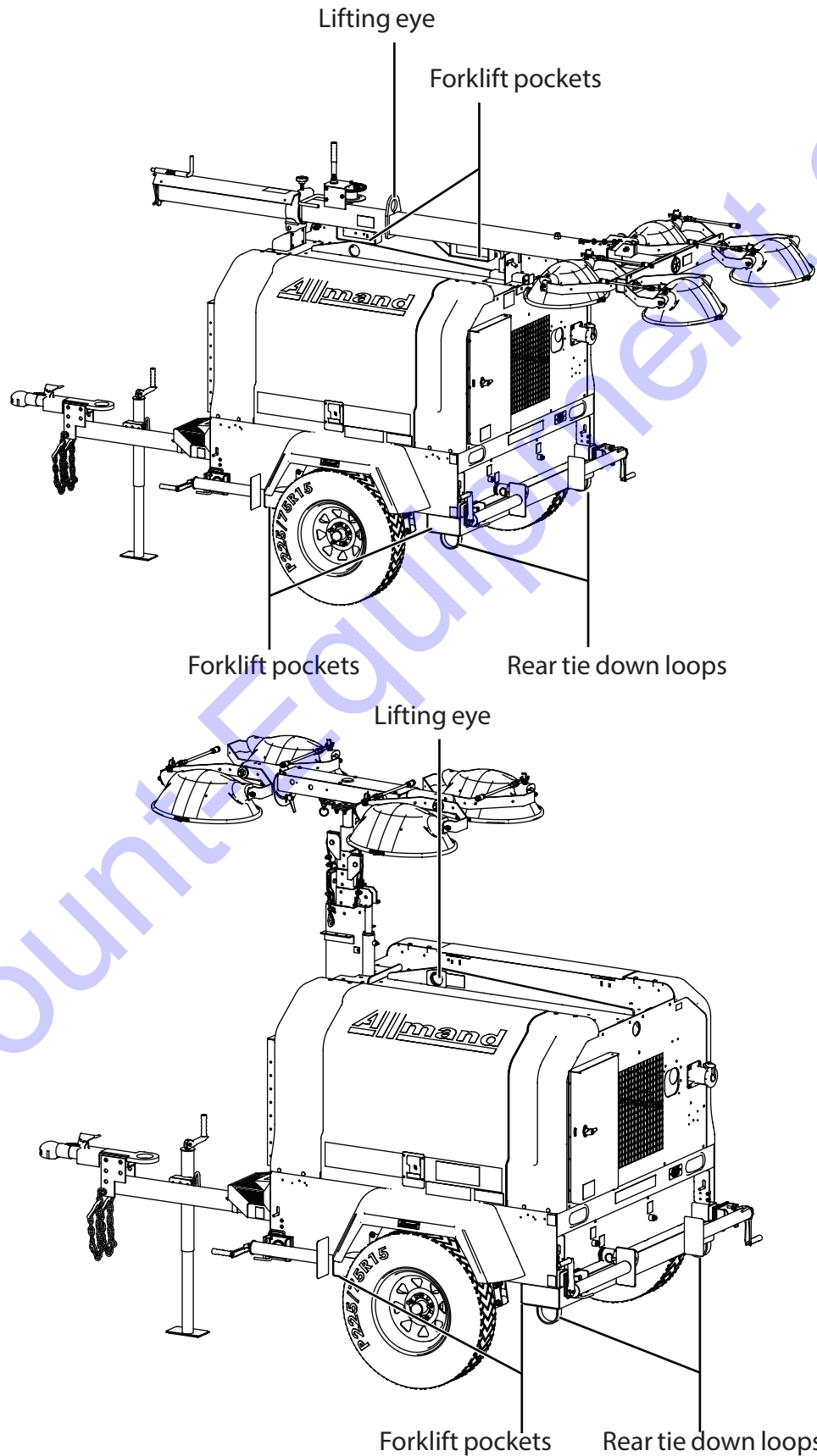



# MAINTAINING THE LIGHT TOWER

MAXI-LITE II / MINE SPEC / RIG SPEC

<b>GENERAL .....</b>	<b>5-2</b>
<b>MAINTAINING THE ENGINE .....</b>	<b>5-5</b>
<b>CHANGING AND ADDING ENGINE OIL.....</b>	<b>5-5</b>
<b>CHANGING THE ENGINE FILTERS.....</b>	<b>5-5</b>
<b>MAINTAINING THE ELECTRICAL SYSTEM.....</b>	<b>5-6</b>
<b>BALLAST PANEL.....</b>	<b>5-6</b>
<b>MAINTAINING THE HYDRAULIC PUMP .....</b>	<b>5-7</b>
<b>HYDRAULIC FLUID SPECIFICATION .....</b>	<b>5-7</b>
<b>ADDING HYDRAULIC FLUID .....</b>	<b>5-7</b>
<b>PRIMING THE HYDRAULIC PUMP .....</b>	<b>5-7</b>
<b>MAINTAINING THE LIGHT TOWER AND LAMPS ....</b>	<b>5-8</b>
<b>CHANGING LAMPS .....</b>	<b>5-8</b>
<b>MAINTAINING THE TRAILER.....</b>	<b>5-8</b>
<b>MAINTAINING THE TRAILER FRAME .....</b>	<b>5-8</b>
<b>MAINTAINING THE WHEELS AND TIRES.....</b>	<b>5-9</b>
<b>CLEANING THE TRAILER AND LIGHT TOWER.....</b>	<b>5-10</b>
<b>CLEANING AND DRAINING THE OPTIONAL FLUID     CONTAINMENT SYSTEM (FCS) .....</b>	<b>5-11</b>
<b>MAINTENANCE RECORD.....</b>	<b>5-12</b>

## GENERAL

Before performing any maintenance procedures, read the chapter on "SAFETY" on page 2-1.

Scheduled maintenance prevents unexpected downtime, reduces the number of accidents due to poor equipment performance, and helps extend the life of the light tower.

Proper maintenance and care of your light tower and trailer is a must for safe and reliable operation. Use the

following maintenance and care guidelines, in addition to those scheduled by your shop equipment maintenance schedule.

Where equipment is operated under severe conditions (very dusty, extreme heat or cold, etc.), your light tower should be serviced more frequently.

The illustrations below show the locations of needed service features (oil filter, dipstick, oil fill; air filter, serial plates, etc.), and specs for each engine - HP, oil capacity, water capacity, etc.

### CAT C1.1 Maintenance Points

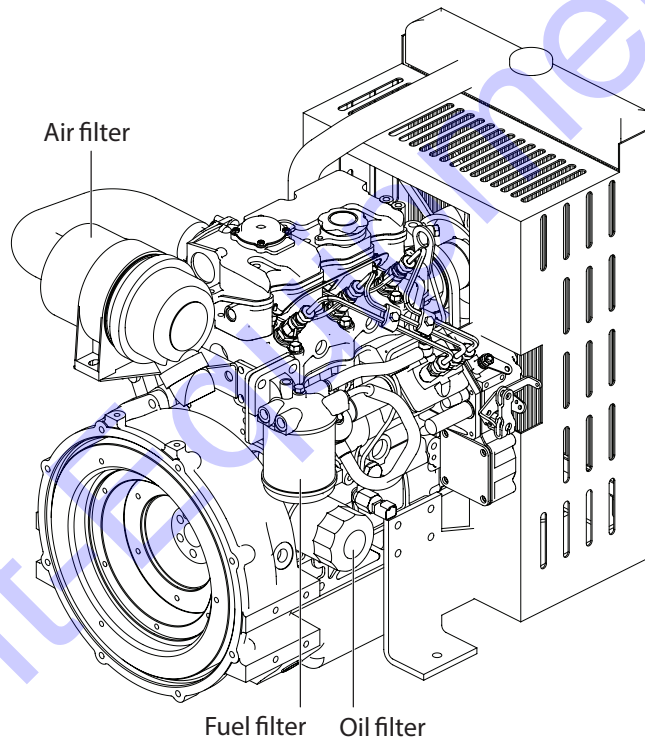

### CAT C1.5 Maintenance Points

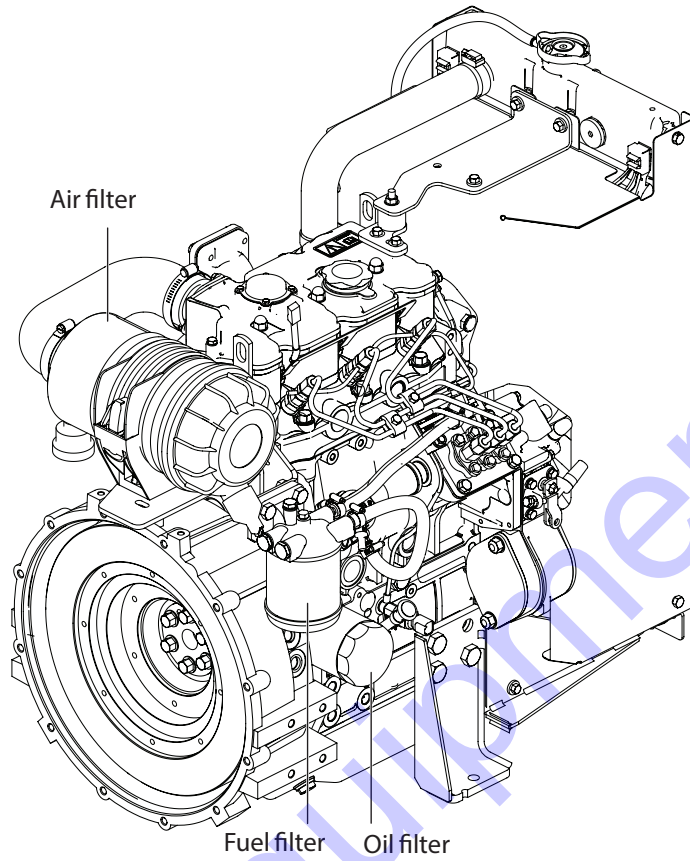

### Isuzu 4LE Maintenance Points

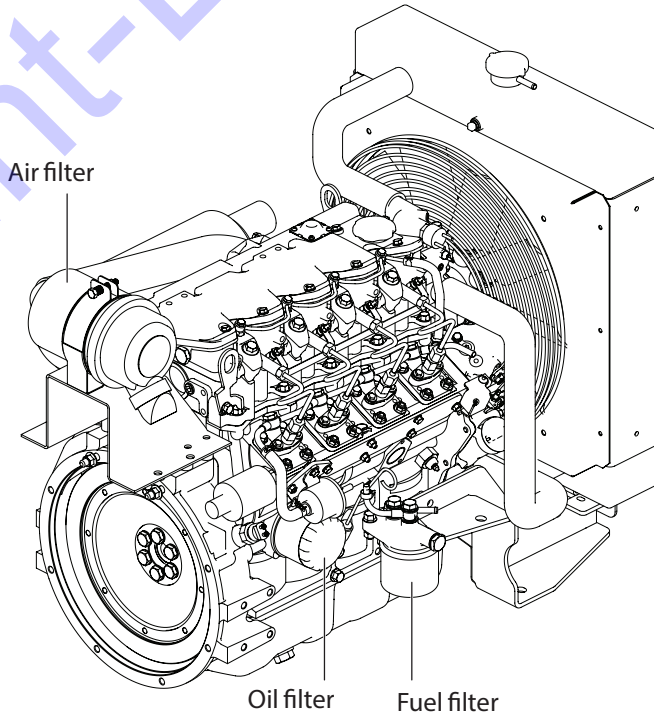

### Kubota D1005 & D1105 Maintenance Points

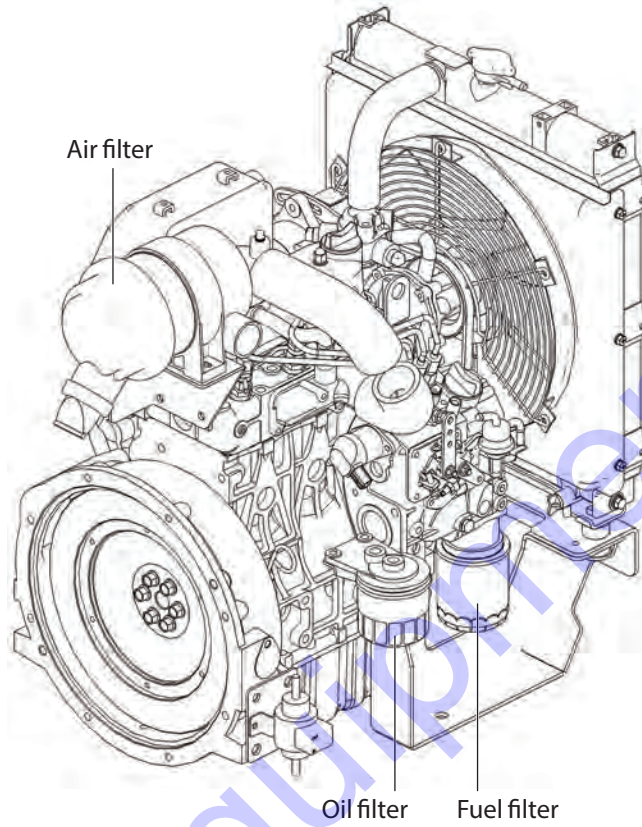

## MAINTAINING THE ENGINE

Refer to the *Engine Operator's Manual* for all scheduled engine maintenance procedures.

### CHANGING AND ADDING ENGINE OIL

Use a high-quality engine oil of API (American Petroleum Institute) service class CC/CD/CE. Refer to the *Engine Operator's Manual* for detailed engine oil specifications and service procedures.

All models are equipped with remote oil drains.

#### To change the engine oil:

- 1 Start the engine and let it warm up.
- 2 Place a drain pan under the remote oil drain.
- 3 Remove the oil drain plug and let the oil drain into the pan until empty.
- 4 Replace the oil drain plug and dispose of the old oil in a responsible manner.
- 5 Remove the oil fill cap from the top of the engine.
- 6 Add clean oil per the stated capacity.
- 7 Replace the oil fill cap.
- 8 Start the engine and let it warm up, then check for leaks.

## CHANGING THE ENGINE FILTERS

Refer to the *Engine Operator's Manual* for air, oil, and fuel filter part numbers and service procedures.

#### To change the engine oil filter (always do this when you change the oil):

- 1 Place a drain pan under the engine oil filter.
- 2 Remove the old oil filter with an oil filter wrench, then dispose of the old filter.
- 3 Using new oil, coat the rubber gasket on the new oil filter.
- 4 Install the new oil filter by threading it onto the spin-on bracket, then tighten with the filter wrench. Do not over-tighten.
- 5 Start the engine and let it warm up, then check for leaks.

#### To change the engine air filter:

- 1 Remove the top of the air cleaner.
- 2 Remove and dispose of the old air filter element.
- 3 Install the new air filter element.
- 4 Replace the top of the air cleaner.

## MAINTAINING THE ELECTRICAL SYSTEM

Refer to the *Generator Operator's Manual* for all general scheduled maintenance procedures.

### BALLAST PANEL

The ballast panel is located on the left, front side of the light tower trailer. The ballast panel can be accessed by removing the left side panel, then removing the internal access cover. The ballast panel contains the four tower light lamp ballasts and capacitors.

The safety messages that follow have **WARNING** level electrocution hazards.

#### **WARNING**

##### **ELECTROCUTION HAZARD**

Only qualified electricians should service or perform replacement procedures. Ballasts and capacitors are capable of discharging high voltage. Always use appropriate personal safety clothing and gear when servicing electrical equipment.

#### **WARNING**

##### **ELECTROCUTION HAZARD**

High voltage is present when the engine is running. Never attempt to service electrical components while the engine is running.

#### **WARNING**

##### **ELECTROCUTION HAZARD**

Do not operate the light tower if the insulation on the electrical wiring is cut or worn, or if bare wires are exposed. Repair or replace damaged wiring before starting the engine.

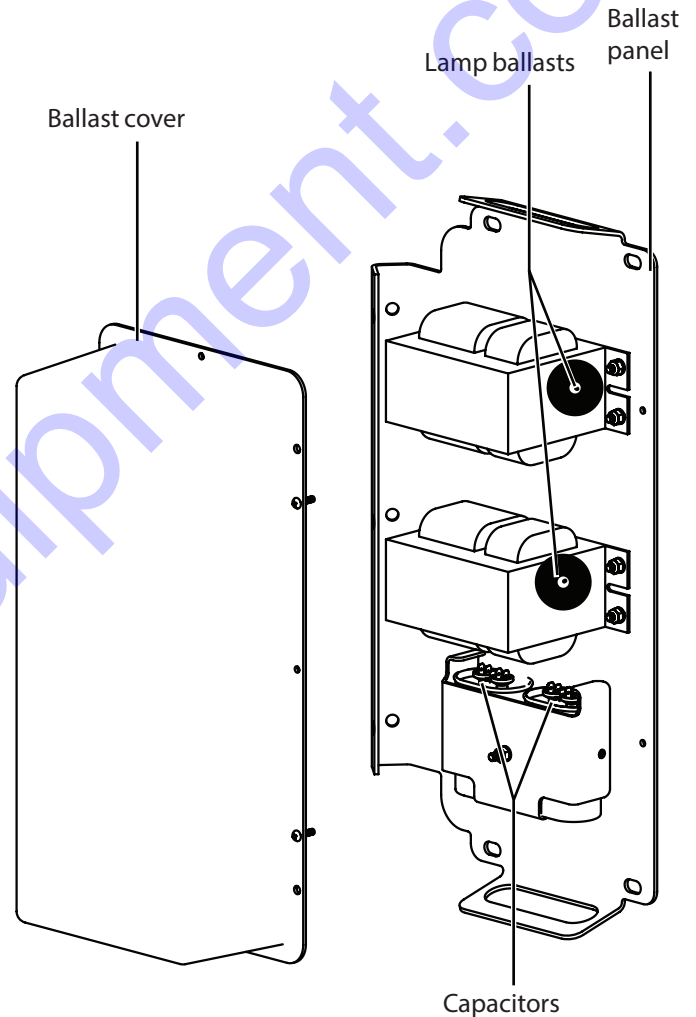



## MAINTAINING THE HYDRAULIC PUMP

### HYDRAULIC FLUID SPECIFICATION

Recommended Hydraulic Fluids

USE LONG LIFE SYNTHETIC HYDRAULIC FLUID SUCH AS PENTOCIN CHF 113											
USE AUTOMATIC TRANSMISSION FLUID											
-40	-30	-20	10	0	10	20	30	40	50	°C	
-40	-22	-4	14	32	50	68	86	104	122	°F	
Ambient Temperature											

### ADDING HYDRAULIC FLUID

Fill the reservoir with aviation hydraulic fluid or any clean hydraulic fluid having a viscosity index that is suitable for the climate conditions in which the unit will be operated. Refer to the preceding table. Standard units are supplied with automatic transmission fluid (ATF), and arctic units are supplied with long life synthetic hydraulic fluid.

### PRIMING THE HYDRAULIC PUMP

Pumps that have been disassembled for repair, or pumps that have been replaced require proper priming to avoid possible pump failure. A pump is said to be "primed" when the internal portions of the pump are filled with oil and all air has been expelled.

#### To prime the hydraulic pump:

- 1 Make sure that the oil reservoir is filled with oil to the full mark.
- 2 Place a catch pan under the pump to catch excess oil.
- 3 Loosen the hose end to allow oil and air to escape.
- 4 Turn on the ignition switch and move the tower raise / lower switch to the "raise" or up position. Do so intermittently, or "jog" the pump. This will expel air and oil through the loosened fitting. Repeat until oil flow is free of air.
- 5 Re-tighten the hose end. Turn off the ignition switch.
- 6 Remove the catch pan and dispose of the oil following the guidelines of governmental agencies.
- 7 Replenish the oil in the reservoir to the full mark.

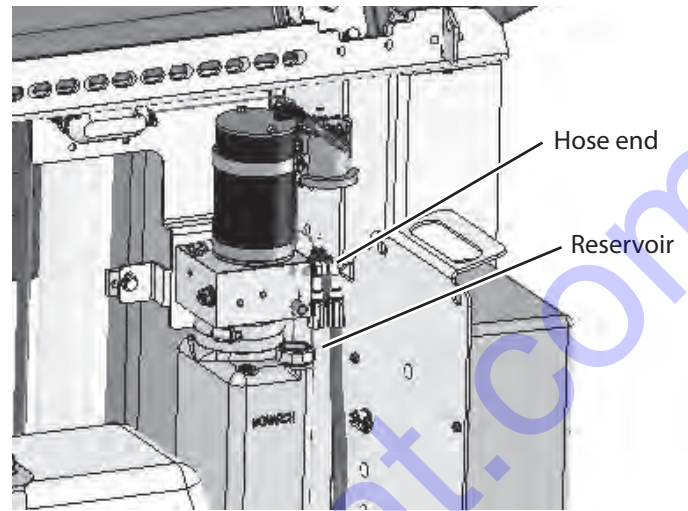

Once the pump has been primed, the cylinder should be purged of air. To purge the cylinder of air:

- 1 Make sure that the oil reservoir is filled with oil to the full mark.
- 2 Clean the bleeder fitting on the upper end of the cylinder barrel.
- 3 Place a bleeder hose over the end of the bleeder fitting. Place the other end of the bleeder hose in a suitable catch container.
- 4 Turn on the ignition switch and move the tower raise / lower switch to the "raise" or up position.
- 5 Open the bleeder fitting. Allow oil and air to bleed out of the cylinder. Close the bleeder when oil flow is free of air.
- 6 Remove the catch container and the bleeder hose. Dispose of the oil in the catch container following the guidelines of governmental agencies.
- 7 Move the tower raise / lower switch to the "lower" or down position. Be sure that the tower is fully lowered. Turn off the ignition switch.
- 8 Replenish the oil in the reservoir to the full mark.

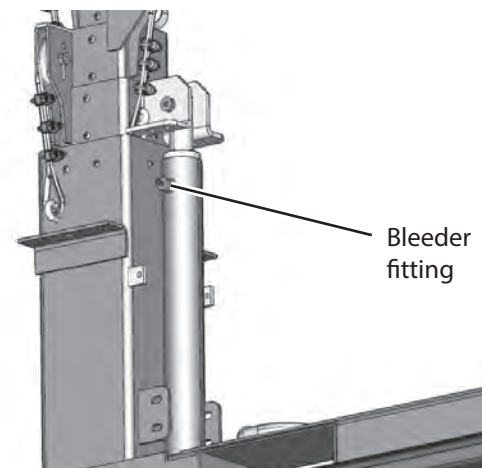

## MAINTAINING THE LIGHT TOWER AND LAMPS

### CHANGING LAMPS

#### **! WARNING**

#### **BURN HAZARD**

The light bulbs and fixtures become extremely hot during use. Allow the bulbs and fixtures to sufficiently cool down before changing bulbs or severe burns may occur.

#### To change the lamps:

- 1 Turn off the lights and shut off the engine. Allow the bulbs and fixtures to cool.
- 2 Lower the light tower to the full down position.
- 3 Loosen the lens channel screws to allow the removal of the lens channel.
- 4 Remove the silicone gasket and lens.
- 5 Remove the support clip screws and support clip.
- 6 Carefully remove the old lamp and install the correct replacement.
- 7 Clean the reflector and lens.
- 8 Install the support clip and screws.
- 9 Install the silicone gasket and lens (replace if damaged).
- 10 Install the lens channel and screws.
- 11 Test the new lamp to make sure that it operates properly.

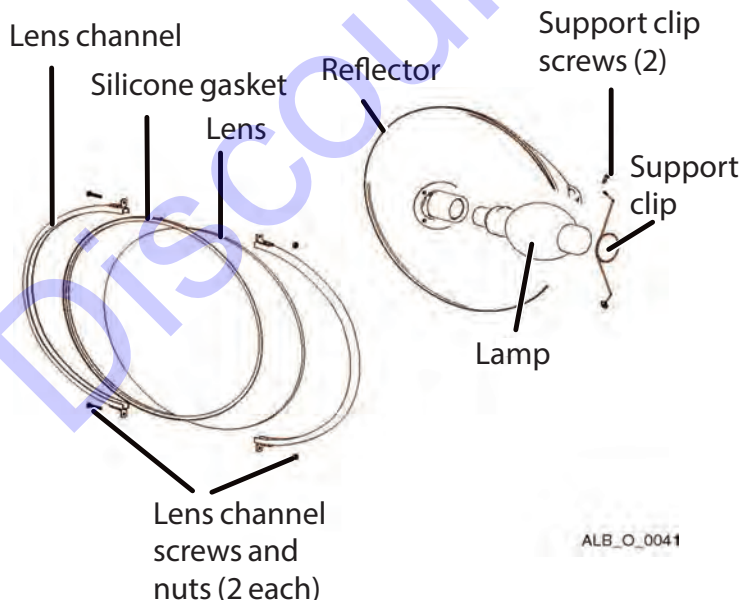

ALB\_O\_0041

## MAINTAINING THE TRAILER

Proper maintenance and care of your trailer is a must for safe and reliable operation. Follow these maintenance and care guidelines in addition to those scheduled by your shop equipment maintenance schedule.

### MAINTAINING THE TRAILER FRAME

#### To maintain the trailer frame:

- 1 Check the coupler operation. Also check for corrosion or damage. Repair or replace as needed.
- 2 Inspect the lifting bar for corrosion or damage and repair or replace as needed.
- 3 Inspect the trailer frame and body panels for rust, nicks, and chips. Use the proper touch-up paint to touch up nicks or scratches. Contact your dealer for additional information.
- 4 Inspect the axle, springs, and undercarriage for wear and damage. Repair or replace as needed.
- 5 Inspect the outrigger bars, front and rear stabilizer jacks, and locking mechanisms for proper operation, wear, and damage. Repair or replace as needed.
- 6 Inspect the safety chains for wear and corrosion damage. Repair or replace as needed.

## LUBRICATING THE TRAILER

Use N.G.L.I. consistency #2 high-temperature anti-friction bearing lubricating grease for all mechanical pivot points on the trailer.

## MAINTAINING THE WHEELS AND TIRES

### WARNING

#### TOWING HAZARD

Never tow the trailer with damaged tires, rims, or lug nuts.

### To maintain the wheels and tires:

- 1 Check the tires for any cracks, cuts, or damage. Repair or replace the damaged tires before towing.
- 2 Check the air pressure of the trailer tires when cold. The correct air pressure for the tire is specified on the tire. Never over- or under-inflate tires.
- 3 Check the wheel rims for any cracks or damage. Repair or replace as needed.
- 4 Make sure that all the lug nuts are in place and are properly torqued. The correct torque for the lug nuts is 90 lb-ft (122 N-m).
- 5 When torquing lug nuts, always use a criss-cross pattern, as indicated below.

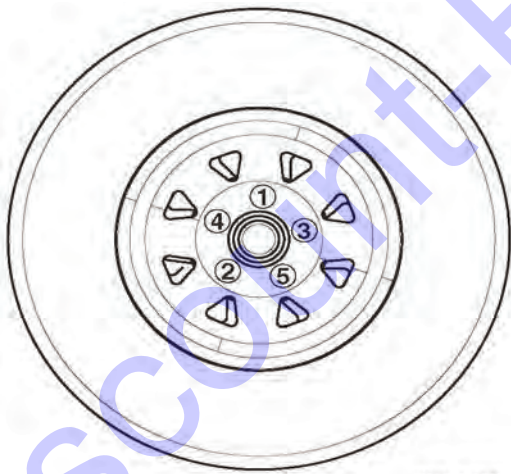

## MAINTAINING THE WHEEL BEARINGS

Typical wheel hub bearing assembly

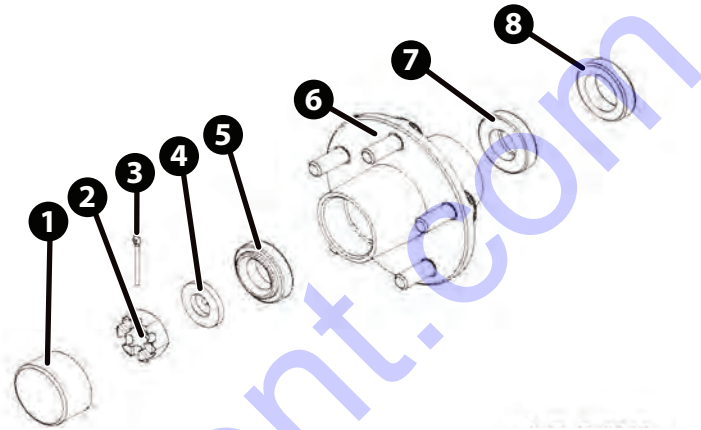

- 1 - Dust cover
- 2 - Castle nut
- 3 - Cotter pin
- 4 - Washer
- 5 - Outer hub wheel bearing
- 6 - Wheel hub
- 7 - Inner hub wheel bearing
- 8 - Hub grease seal

Wheel bearings require scheduled maintenance and periodic replacement. More frequent service may be required under extremely dusty or damp operating conditions. The best protection against failure is to keep the wheel bearings clean and fully lubricated.

When replacing or repacking wheel bearings, always:

- Use a high-quality wheel bearing grease.
- Avoid mixing grease types.
- Clean all components thoroughly of all old grease and inspect for damage or wear. Replace components as needed.
- Use a new grease seal and cotter pin.
- Keep all components clean during assembly.
- Replace questionable components.
- Replace bearings and races as a set. Never mix bearings and races. Bearing part numbers are sometimes found on the bearing races. Use the correct bearing set.
- Pack grease into the bearing prior to installation.

- Do not over- or under-tighten the bearing nut. Wheel bearings should only be tightened by hand (spin the wheel while tightening). Back off the nut to insert the cotter pin. The wheel should spin freely, but without play.
- Pack some grease into the inner hub area and dust cap and make sure that the dust cap fits tightly.

### MAINTAINING THE TRAILER LIGHTS

#### WARNING

#### TOWING HAZARD

Never tow the trailer with lights that don't work.

Lights are a vital safety feature of your trailer and are required by state law. Keep the lights in proper working order by doing the following:

- Check the trailer lights and wiring harness for damage or wear. Repair or replace as needed.
- Make sure that the wiring harness is secured to the trailer and does not hang down onto the ground.
- Check the tail light housing assemblies for damage or leaks. Use silicone or rubber sealant to seal the lens or wiring harness, if needed, or replace the housing assembly if it can't be sealed. Electrical grease will help protect the sockets and prevent corrosion.
- When replacing bulbs, make sure that you use the proper bulb.

## CLEANING THE TRAILER AND LIGHT TOWER

Keeping the light tower clean is important to ensure proper operation. Dirt and dust buildup acts as an insulator and may cause the engine, generator, and light assemblies to operate at excessively high temperatures.

Use the following guidelines to clean your light tower:

- Use caution when using compressed air or water/steam pressure washers. Do not pressure-clean electrical components, because it may damage electrical components.
- Clean the light tower and remove all dust, dirt, or other foreign material.
- Remove dust, dirt, and debris from the radiator.
- Inspect and clean the cooling air intake and exhaust louvers of the enclosure. Remove dirt or any buildup that may restrict the cooling air flow.
- If you use a pressure washer, do not direct the spray on the following areas:
  - 
  - 
  -
- Inspect and clean all engine linkages so they operate properly.

**CLEANING AND DRAINING THE OPTIONAL  
FLUID CONTAINMENT SYSTEM (FCS)**

All light towers are equipped with a sealed bilge, designed to catch fuel, oil, or coolant spills. It can hold up to 110% of all onboard fluids/liquids. Should a spill occur, position a suitable container beneath the unit and remove the bilge drain plug. After the fluid has been drained, reinstall the drain plug and dispose of the fluid properly in accordance with EPA or other governmental guidelines.

Discount-Equipment.com



# SPECIFICATIONS

MAXI LITE II / MINE SPEC / RIG SPEC

<b>SPECIFICATIONS (STANDARD AND OPTIONAL FEATURES) .....</b>	<b>6-2</b>
<b>EQUIPMENT IDENTIFICATION .....</b>	<b>6-2</b>
<b>MODEL AND SERIAL NUMBERS .....</b>	<b>6-6</b>
<b>GENERATOR .....</b>	<b>6-6</b>
<b>OVERALL DIMENSIONS .....</b>	<b>6-7</b>
<b>STANDARD AND OPTIONAL FEATURES.....</b>	<b>6-7</b>
<b>OPTIONAL ACCESSORY EQUIPMENT .....</b>	<b>6-8</b>
<b>GENERAL SERVICE INFORMATION.....</b>	<b>6-9</b>

Discount-Equipment.com



## SPECIFICATIONS (STANDARD AND OPTIONAL FEATURES)

### EQUIPMENT IDENTIFICATION - Laydown Front

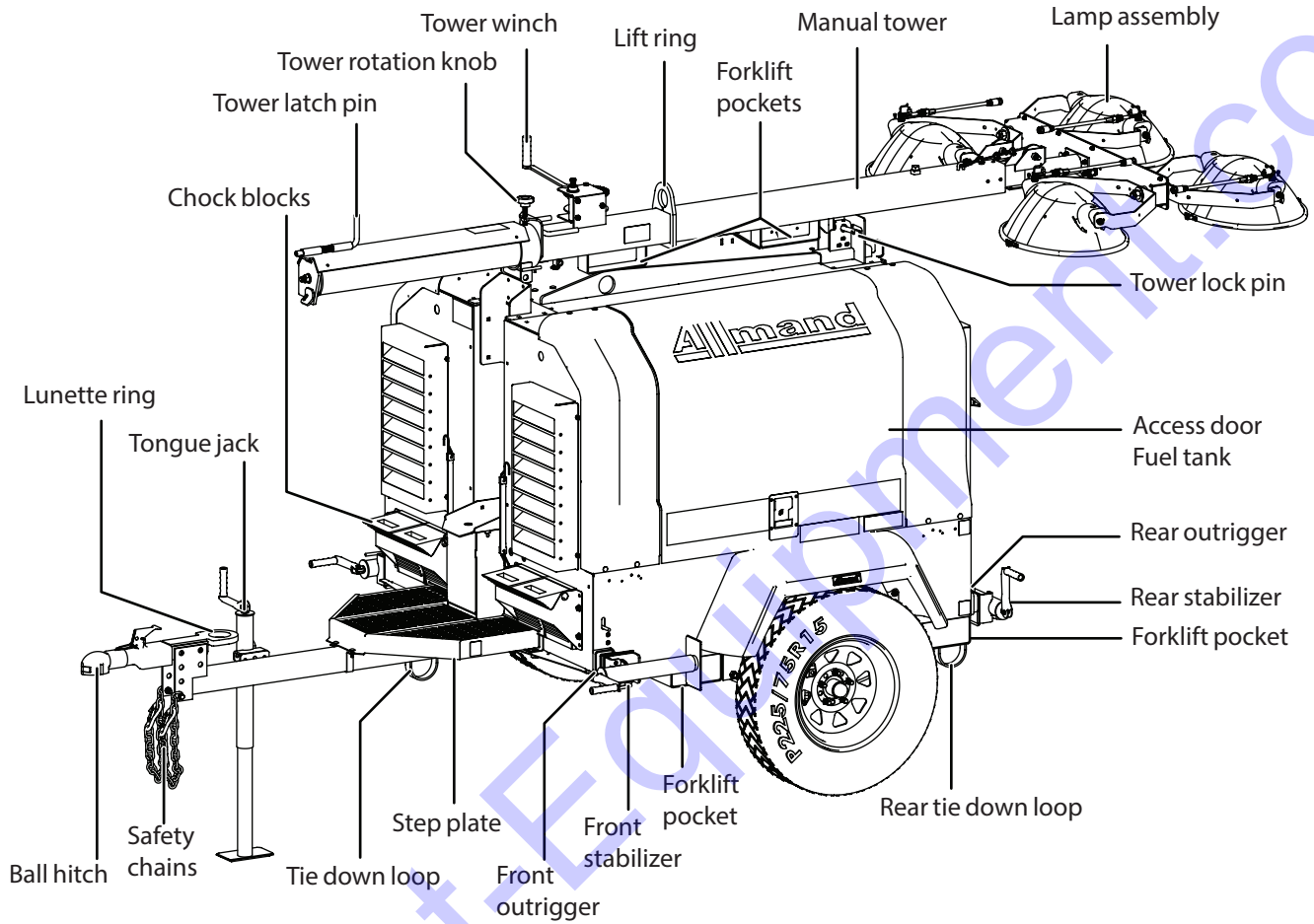

### EQUIPMENT IDENTIFICATION - Laydown Rear

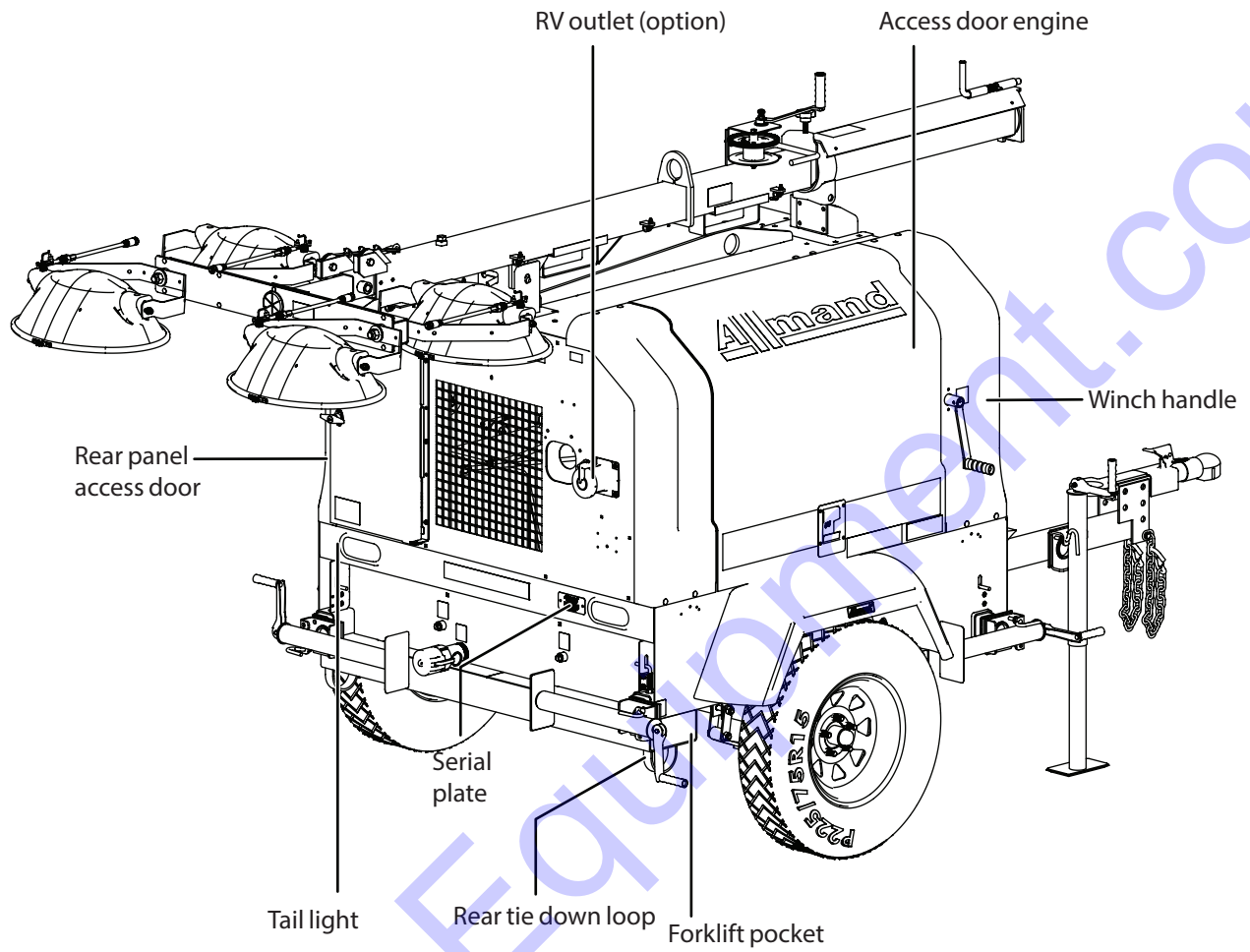



EQUIPMENT IDENTIFICATION - Vertical Front (Four-light model shown)

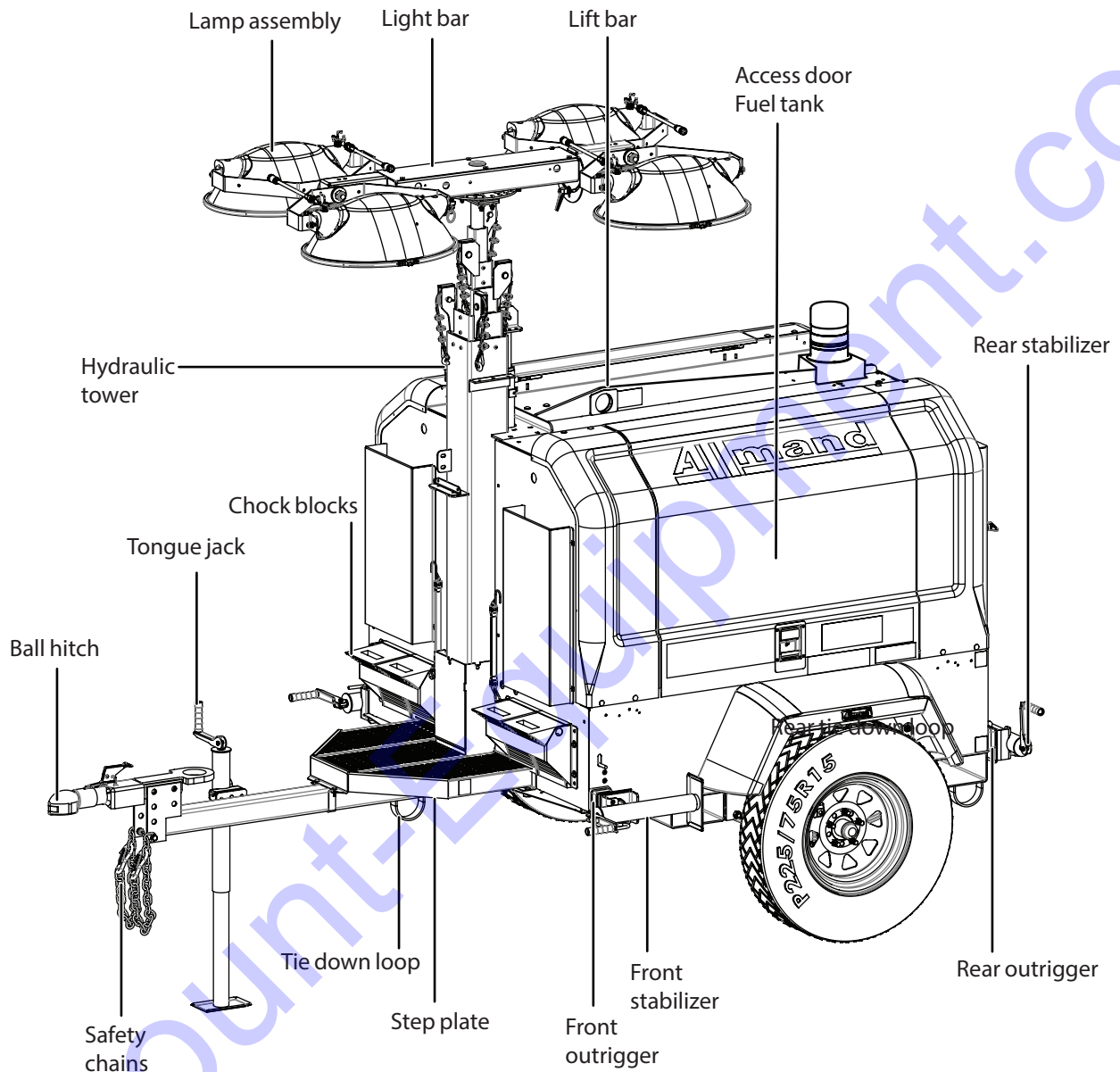

**EQUIPMENT IDENTIFICATION - Vertical Rear (Four-light model shown)**

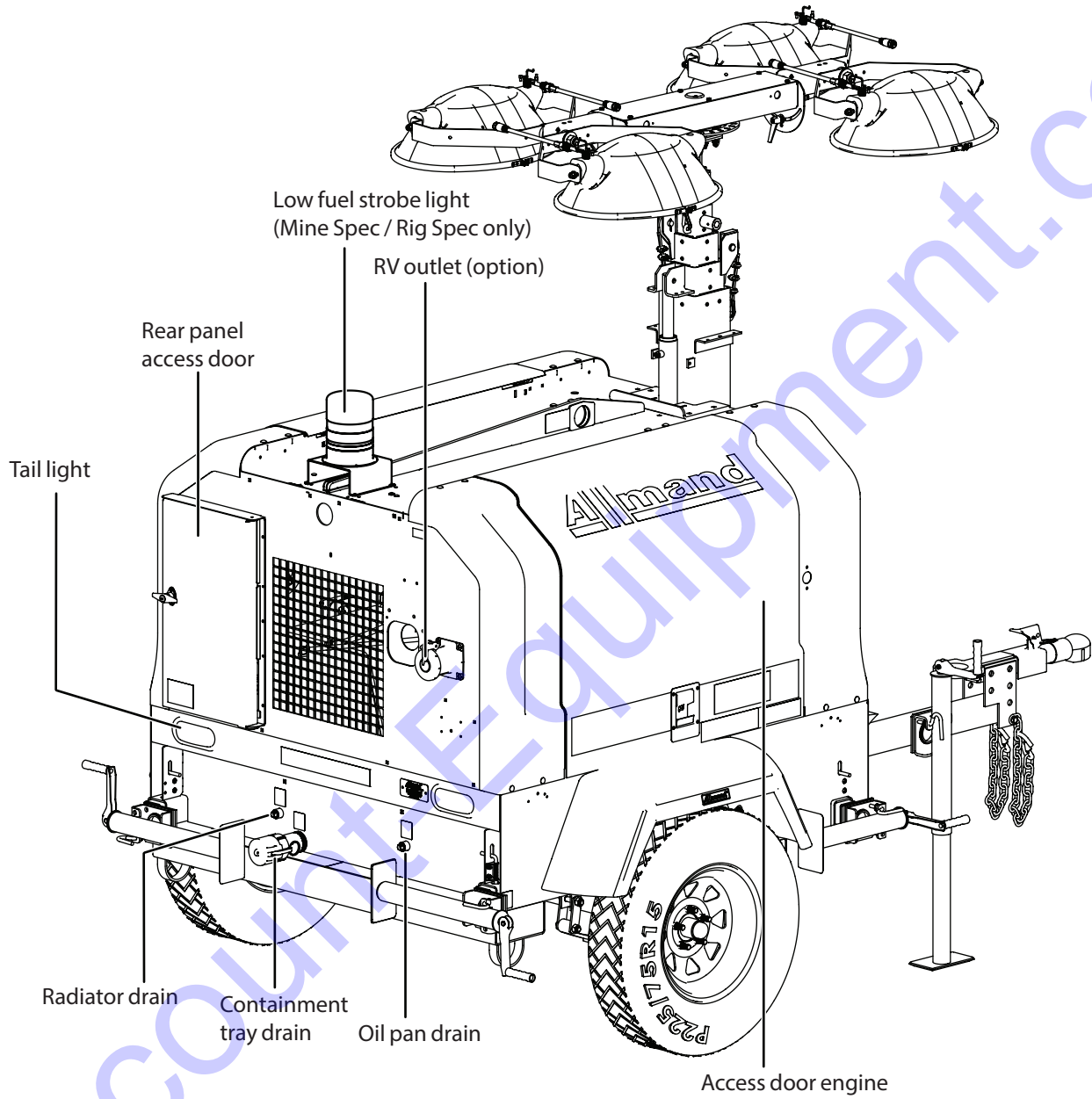

## MODEL AND SERIAL NUMBERS

Model and serial number information is required for product support and to order parts. The following descriptions show model and serial number locations on the primary trailer and light tower components.

### TRAILER

All trailers have a serial number plate on the rear panel.

### GENERATOR

The generators have a serial number stamped into the top side of the housing.

### ENGINES

#### CAT engine

The Caterpillar® engine has the serial number plate attached to the upper-right side of the engine block, above the fuel injection pump.

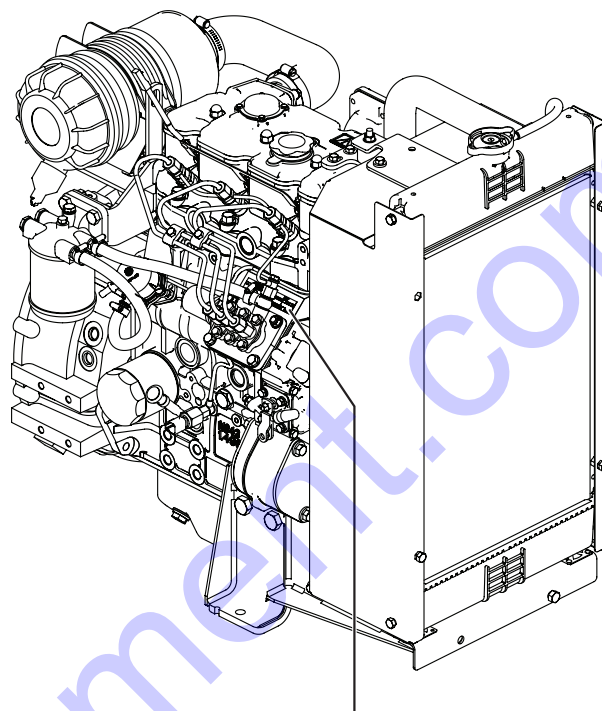

CAT C1.5 Engine serial plate

#### Kubota

The Kubota engine has the serial number plate attached to the left side of the engine block.

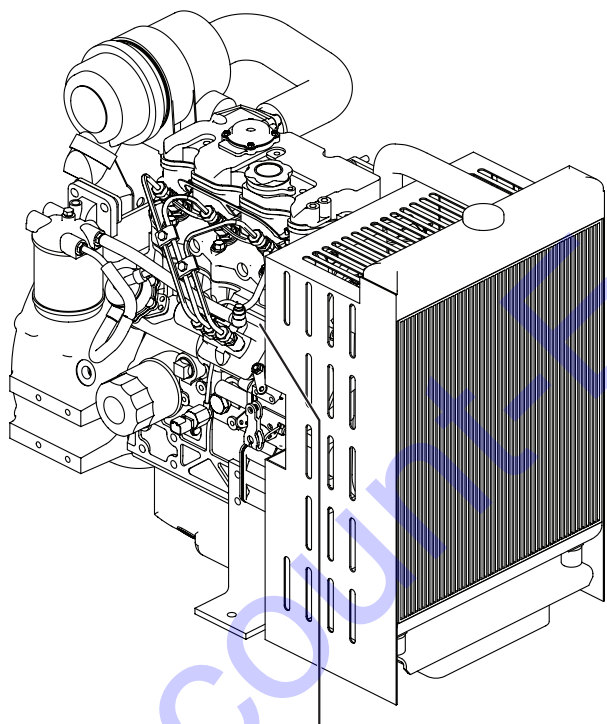

CAT C1.1 Engine serial plate

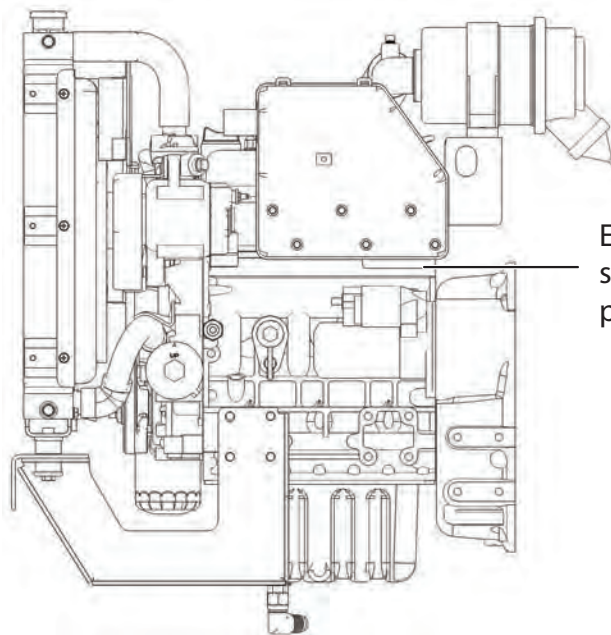

Engine serial plate

**Isuzu**

The Isuzu engine has the serial number plate attached to the left side of the engine block by the oil filter.

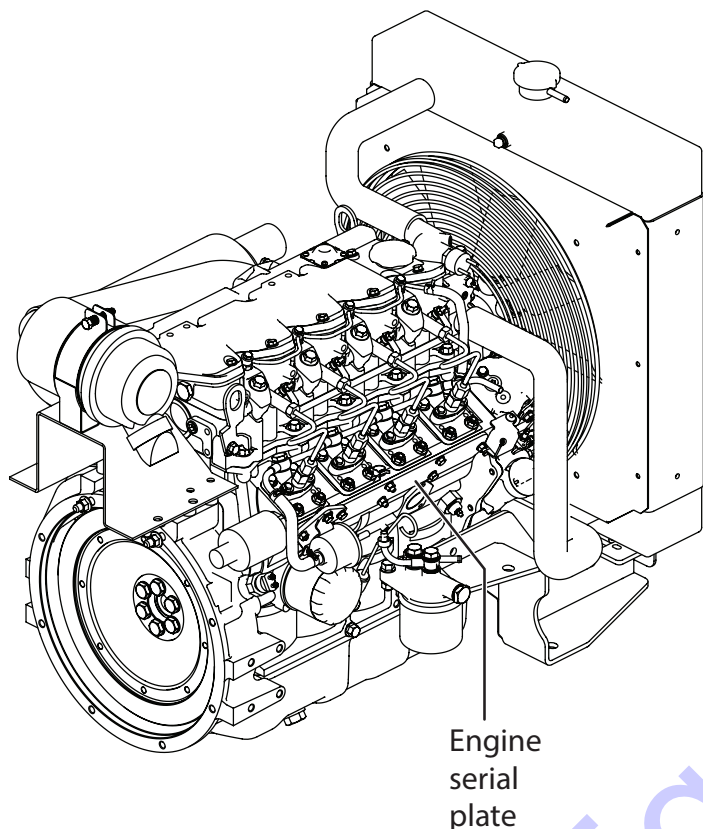

**OVERALL DIMENSIONS**

	<b>Hydraulic Tower</b>
Height Light Tower Lowered	7 ft. 8 in. (2.34 m)
Height Light Tower Raised	25 ft. 6 in. (7.8 m)
Width (outriggers retracted)	74 in. (1.9 m)
Width (outriggers extended)	12 ft. 10 in. (3.91 m)
Length w/o fixtures	10 ft. 4 in. (3.14 m)
Length with fixtures	10 ft. 4 in. (3.14 m)
Dry Weight (6 lights)	2,537 lbs (1050 kg)

**STANDARD AND OPTIONAL FEATURES**

**NOTICE**

Refer to the *Engine Operator's Manual* or the *Generator Operator's Manual* for specific engine or generator specifications.

**TRAILER**

	<b>3" Pintle Hitch</b>
Max. road speed (paved road)	60 mph (97 km/h)
Max off-road speed	20 mph (32 km/h)
Axles	1
Axle rating	5000 lbs (2268 kg)
Tire size/rating	15 in. C
Max. tire pressure	See tire manufacturer spec.
Door locks	Standard
Trailer lights	Stop, turn, running - DOT approved
Trailer light connector	4-pin plug
Lifting eye	Standard
Tie-down rings	Standard
Top forklift pockets	Standard
Stabilizers	Four (4)
Outrigger stabilizers	Two (2)
Tongue jack	Standard
Ground rod	Standard

**LIGHT TOWER (Hydraulic)**

Sections	Seven (7)
Hydraulic cylinder	Standard
Vertical	Standard
Max. wind load	53 mph (85.3 km/h)
Light bar rotation	360°
Tower cord reel	Standard

**TOWER LIGHTS**

SHO-HD 1000W and 1250 metal halide	Restart - 10-15 minutes
Four fixtures	Standard
Max. wind load	53 mph (85.3 km/h)
Light bar weight	15 lbs (6.75 kg)
<b>Individual light switches</b>	
1000W light switch (two per four lights)	Optional
1000W light switch (four per four lights)	Standard (Can) Optional (USA)
1250W light switch (two per light)	Optional (USA) N/A (Can)
Individual ballast (one per light)	Standard

**GENERATOR**

20 kW	Standard
120VAC convenience outlet	Standard
125/250VAC twist-lock convenience outlet	Standard
50A service outlet	Standard
208VAC single phase twist-lock outlet	Standard
240VAC three phase convenience outlet	Optional
240VAC single phase convenience outlet	N/A
Main disconnect breaker	Standard

**OPTIONAL ACCESSORY EQUIPMENT**

- Saf-t-Visor
- Electric Winch Tower
- Hydraulic Tower
- LSC100 Light Sequence Commander
- Heavy Duty Battery (700 CCA)
- Battery Heating Pad
- Engine Block Heater
- Sound Attenuation package
- Four or Six Metal Halide or High Pressure Sodium Lamps (5,000, 6,000, or 7,000 Watts Total)
- Seven - Blade RV Taillight Connector
- 50 or 100 gal. Fuel Tank
- Bulldog Hitch (ball/pintle)
- VIN Package (for licensing)
- Quick - Disconnect Lamp Fixtures



**GENERAL SERVICE INFORMATION**

Model	Kubota D1005 (standard engine)
Type	Water-cooled four cycle (diesel)
Bore	2.99 in. (76 mm)
Stroke	2.90 in. (73.7 mm)
Displacement	61.1 cu. in. (1001 cc)
Power @1800 rpm	13.1 hp (9.8 kW)
Power output derating	3% per 1000 ft. (305 m) above sea level and 1% per 10°F above 77°F
<b>Note:</b> Horsepower ratings are established in accordance with the Society of Automotive Engineers Small Engine Test Code - J1349 Gross	
Fuel system	Indirect injected diesel
Starting system	12VDC Negative (-) ground
Electrical system	12VDC Negative (-) ground
Battery type	Group 24
Battery rating	550 CCA
Number of batteries	1
Compression ratio	22.5:1
Weight	204.3 lbs (109 kg)
Oil capacity	5.4 qts (5.1 L)
Lubrication	Forced lubrication by pump
Oil filtration	Cartridge type
Cooling system	Pressurized radiator - forced circulation with water pump
Low pressure engine shutdown	Standard (all engines)
High temperature engine shutdown	
Glow plug cold start assist	
Fuel	Use a clean No.2 diesel fuel oil (SAE J313 JUN87), according to ASTM D795. Do not use an alternative fuel because its quality is unknown and may be inferior. Kerosene, which is very low in octane rating, adversely affects the engine. Refer to the <i>Engine Operator's Manual</i> for more detailed fuel requirements.
Engine oil	Use a high quality engine oil of API (American Petroleum Institute) service class CC/CD/CE. Refer to the <i>Engine Operator's Manual</i> for more detailed lubrication requirements.
Fuel tank	100 Gal. (378.5 L)

Model	Kubota D1105 (optional engine)
Type	Water-cooled four cycle (diesel)
Bore	3.07 in. (78 mm)
Stroke	3.09 in. (78 mm)
Displacement	68.5 cu. in. (1123 cc)
Power @1800 rpm	15.4 hp (11.5 kW)
Power output derating	3% per 1000 ft. (305 m) above sea level and 1% per 10°F above 77°F
<b>Note:</b> Horsepower ratings are established in accordance with the Society of Automotive Engineers Small Engine Test Code - J1349 Gross	
Fuel system	Indirect injected diesel
Starting system	12VDC Negative (-) ground
Electrical system	12VDC Negative (-) ground
Battery type	Group 24
Battery rating	550 CCA
Number of batteries	1
Compression ratio	22.5:1
Weight	204.3 lbs (109 kg)
Oil capacity	5.4 qts (5.1 L)
Lubrication	Forced lubrication by pump
Oil filtration	Cartridge type
Cooling system	Pressurized radiator - forced circulation with water pump
Low pressure engine shutdown	Standard (all engines)
High temperature engine shutdown	
Glow plug cold start assist	
Fuel	Use a clean No.2 diesel fuel oil (SAE J313 JUN87), according to ASTM D795. Do not use an alternative fuel because its quality is unknown and may be inferior. Kerosene, which is very low in octane rating, adversely affects the engine. Refer to the <i>Engine Operator's Manual</i> for more detailed fuel requirements.
Engine oil	Use a high quality engine oil of API (American Petroleum Institute) service class CC/CD/CE. Refer to the <i>Engine Operator's Manual</i> for more detailed lubrication requirements.
Fuel tank	100 Gal. (378.5 L)

Model	CAT C1.1 (optional engine)
Type	Water-cooled four cycle (diesel)
Bore	3.03 in. (77 mm)
Stroke	3.19 in. (81 mm)
Displacement	69 cu. in. (1100 cc)
Power @1800 rpm	14.3 hp (11.9 kW)
Power output derating	3% per 1000 ft. (305 m) above sea level and 1% per 10°F above 77°F
<b>Note:</b> Horsepower ratings are established in accordance with the Society of Automotive Engineers Small Engine Test Code - J1349 Gross	
Fuel system	Indirect injected diesel
Starting system	12VDC Negative (-) ground
Electrical system	12VDC Negative (-) ground
Battery type	Group 24
Battery rating	550 CCA
Number of batteries	1
Compression ratio	23:1
Weight	191 lbs (87 kg)
Oil capacity	3.6 qts (3.4 L) to 4.6 qts (4.4L)
Lubrication	Forced lubrication by pump
Oil filtration	Cartridge type
Cooling system	Pressurized radiator - forced circulation with water pump
Low pressure engine shutdown	Standard (all engines)
High temperature engine shutdown	
Glow plug cold start assist	
Fuel	Use a clean No.2 diesel fuel oil (SAE J313 JUN87), according to ASTM D975. Do not use an alternative fuel because its quality is unknown and may be inferior. Kerosene, which is very low in octane rating, adversely affects the engine. Refer to the <i>Engine Operator's Manual</i> for more detailed fuel requirements.
Engine oil	Use a high quality engine oil of API (American Petroleum Institute) service class CC/CD/CE. Refer to the <i>Engine Operator's Manual</i> for more detailed lubrication requirements.
Fuel tank	100 Gal. (378.5 L)



Model	CAT C1.5 (optional engine)
Type	Water-cooled four cycle (diesel)
Bore	3.3 in. (84 mm)
Stroke	3.5 in. (90 mm)
Displacement	91.0 cu. in. (1491 cc)
Power @1800 rpm	18.8 hp (14 kW)
Power output derating	3% per 1000 ft. (305 m) above sea level and 1% per 10°F above 77°F
<b>Note:</b> Horsepower ratings are established in accordance with the Society of Automotive Engineers Small Engine Test Code - J1349 Gross	
Fuel system	Indirect injected diesel
Starting system	12VDC Negative (-) ground
Electrical system	12VDC Negative (-) ground
Battery type	Group 24
Battery rating	550 CCA
Number of batteries	1
Compression ratio	22.5:1
Weight	191 lbs (87 kg)
Oil capacity	6.3 qts (6 L) Max. 4.8 qts (4.5 L) Min.
Lubrication	Forced lubrication by pump
Oil filtration	Cartridge type
Cooling system	Pressurized radiator - forced circulation with water pump
Low pressure engine shutdown	Standard (all engines)
High temperature engine shutdown	
Glow plug cold start assist	
Fuel	Use a clean No.2 diesel fuel oil (SAE J313 JUN87), according to ASTM D795. Do not use an alternative fuel because its quality is unknown and may be inferior. Kerosene, which is very low in octane rating, adversely affects the engine. Refer to the <i>Engine Operator's Manual</i> for more detailed fuel requirements.
Engine oil	Use a high quality engine oil of API (American Petroleum Institute) service class CC/CD/CE. Refer to the <i>Engine Operator's Manual</i> for more detailed lubrication requirements.
Fuel tank	100 Gal. (378.5 L)

Model	CATTURBO C1.5 (optional engine)
Type	Water-cooled four cycle (diesel)
Bore	3.3 in. (84 mm)
Stroke	3.5 in. (90 mm)
Displacement	91.0 cu. in. (1491 cc)
Power @1800 rpm	18.8 hp (14 kW)
Power output derating	2% per 1000 ft. (305 m) above sea level and 1% per 10°F above 77°F
<b>Note:</b> Horsepower ratings are established in accordance with the Society of Automotive Engineers Small Engine Test Code - J1349 Gross	
Fuel system	Indirect injected diesel
Starting system	12VDC Negative (-) ground
Electrical system	12VDC Negative (-) ground
Battery type	Group 24
Battery rating	550 CCA
Number of batteries	1
Compression ratio	22.5:1
Weight	375 lbs (170 kg)
Oil capacity	6.4 qts (6.1 L) Max. 4.8 qts (4.5 L) Min.
Lubrication	Forced lubrication by pump
Oil filtration	Cartridge type
Cooling system	Pressurized radiator - forced circulation with water pump
Low pressure engine shutdown	Standard (all engines)
High temperature engine shutdown	
Glow plug cold start assist	
Fuel	Use a clean No.2 diesel fuel oil (SAE J313 JUN87), according to ASTM D795. Do not use an alternative fuel because its quality is unknown and may be inferior. Kerosene, which is very low in octane rating, adversely affects the engine. Refer to the <i>Engine Operator's Manual</i> for more detailed fuel requirements.
Engine oil	Use a high quality engine oil of API (American Petroleum Institute) service class CC/CD/CE. Refer to the <i>Engine Operator's Manual</i> for more detailed lubrication requirements.
Fuel tank	100 Gal. (378.5 L)

Model	Isuzu 4LE1 (optional engine)
Type	Water-cooled four cycle (diesel)
Bore	3.35 in. (85 mm)
Stroke	3.78 in. (96 mm)
Displacement	133 cu. in. (2179 cc)
Power @1800 rpm	31.4 bhp
Power output derating	3.5% per 1000 ft. (305 m) above sea level and 1% per 10°F above 77°F
<b>Note:</b> Horsepower ratings are established in accordance with the Society of Automotive Engineers Small Engine Test Code - J1349 Gross	
Fuel system	Indirect injected diesel
Starting system	12VDC Negative (-) ground
Electrical system	12VDC Negative (-) ground
Battery type	Group 24
Battery rating	450 CCA
Number of batteries	1
Compression ratio	21.5:1
Weight	387 lbs (175 kg)
Oil capacity	Max. 8.5 qts (8.0 L), Min. 5.6 qts (5.3 L)
Lubrication	Forced lubrication by pump
Oil filtration	Cartridge type
Cooling system	Pressurized radiator - forced circulation with water pump
Low pressure engine shutdown	Standard (all engines)
High temperature engine shutdown	
Glow plug cold start assist	
Fuel	Use a clean No.2 diesel fuel oil (SAE J313 JUN87), according to ASTM D975. Refer to the <i>Engine Operator's Manual</i> for more detailed fuel requirements.
Engine oil	Use a high quality engine oil of API (American Petroleum Institute) service class CC/CD/CE. Refer to the <i>Engine Operator's Manual</i> for more detailed lubrication requirements.
Fuel tank	50 Gal. (189 L), (70 Gal. optional [264 L])



## **TROUBLESHOOTING**

MAXI LITE II / MINE SPEC / RIG SPEC

**TROUBLESHOOTING ..... 7-2**

**TROUBLESHOOTING CHART ..... 7-3**

Discount-Equipment.com



## TROUBLESHOOTING

Before performing any troubleshooting procedures, read the following safety messages and read the chapter on “SAFETY” on page 2-1

For engine and generator troubleshooting, refer to the *Engine Operator's Manual* and *Generator Operator's Manual* or contact your dealer.

### **WARNING**

#### **ELECTROCUTION HAZARD**

Only qualified, licensed electricians should service or perform replacement procedures on the electrical components. Ballast and capacitors are capable of discharging high voltage. Always use appropriate personal safety clothing and gear when servicing electrical components.

### **WARNING**

#### **ELECTROCUTION HAZARD**

High voltage is present when the engine is running. Never attempt to service electrical components while the engine is running.

### **WARNING**

#### **ELECTROCUTION HAZARD**

Do not operate the light tower if the insulation on the electrical wiring is cut or worn, or if bare wires are exposed. Repair or replace damaged wiring before starting the engine.

Always follow the electrical component manufacturer's specifications for voltage and test procedures

## TROUBLESHOOTING CHART

PROBLEM	Possible Cause
<b>No light from one or more lights</b>	The circuit breakers on the outlet box are not turned on or have been tripped. If necessary clear the overload condition, then allow 15 minutes and reset the breakers.
	The lamps have not been allowed to cool sufficiently from the last use. Allow 15 minutes between the time the lamps are turned off and the time they are restarted.
	One or more lamps are burned out or broken. Replace the lamp(s).
	One or more lamps are not screwed in securely. Screw the lamp(s) in securely.
	The plug and socket at the light bar are not securely connected and locked.
	The temperature of the ballast is below -20° F (-29° C). The efficiency of the capacitors in the ballast is not sufficient to light the lamps. For operations where the temperature of the ballast falls below -20° F (-29° C), some means must be used to warm the ballast.
	Low electrical system voltage.
	A loose connection is possible in the back of the lamp socket in the lamp holder. Turn off the engine and repair the loose connection.
	A circuit breaker or breakers are defective. Repair or replace the circuit breaker(s).
	A loose connection is possible on the terminal board. Turn off the engine and check the connections.
	The engine and generator are not running up to speed (1800 RPM).
	An incorrect style replacement lamp (requiring a different ballast) has been installed. Replace the lamp with the correct replacement.
	Too much power is being drawn from the auxiliary outlets. Remove some of the load from the auxiliary outlets.
	A capacitor or transformer has failed. Replace the defective part.
Corrosion has occurred on the lamp bases. Turn off the engine and allow the lamps to cool, then remove the lamps and clean the bases.	



## WARRANTY

MAXI LITE II / MINE SPEC / RIG SPEC

Discount-Equipment.com



**ALLMAND BROS. INC. WARRANTY POLICY**

**LIMITED WARRANTY**

Allmand Bros. Inc. warrants to the original purchaser that, during the warranty period specified below, it will repair or replace at manufacturer's discretion, free of charge, any part that is defective in material or workmanship or both, or to refund the cost of the product if it is determined by the manufacturer that repair or replacement will not return the goods to proper working order or utility. This warranty is effective for and is subject to the time periods and conditions stated below.

**There is no other express warranty. Implied warranties, including those of merchantability or fitness for a particular purpose, are limited to the warranty period listed below, or to the extent permitted by law. Liability for incidental or consequential damages are excluded to the extent exclusion is permitted by law.** Some states or countries do not allow limitations on how long an implied warranty lasts, and some states or countries do not allow the exclusion or limitation of incidental or consequential damages, so the above limitation or exclusion may not apply to you. This warranty gives you specific legal rights and you may also have other rights which vary from state to state or country to country.\*\*

**WARRANTY PERIOD**

Product	Warranty
Lighting Systems	2 years *
1250-Watt Ballast	2 years
Arrowboard AB2220	3 years
Arrowboard AB2400	3 years
LED Lamps	5 years
Solar Panels	10 years
Maxi-Heat	1 year
Replacement Parts	90 days

Product	Warranty
Generator	See Generator Manufacturer's Warranty
Engine	See Engine Manufacturer's Warranty

*\* 2nd year - parts only; no labor (only parts manufactured by Allmand Bros. Inc)*

The warranty begins on the date of original purchase (invoice date). If you do not provide proof of the invoice date at the time warranty service is requested, the manufacturing date of the product will be used to determine the warranty period. The original purchaser is deemed to be the first person or entity that acquires the product for actual use. The warranty does not transfer to subsequent purchasers. Any person or entity holding products for wholesale or retail sale is not considered an original purchaser. However, leasing or using the product beyond normal demonstration purposes is considered to be "actual use" by an original purchaser, and the warranty period will begin on the first date of such use.

Transportation charges on parts or product submitted to the factory for repair or replacement under this warranty shall be borne by the purchaser. If it is subsequently determined that the parts are warrantable, the cost of the transportation charges will be credited back to the purchaser. Air freight for international shipments of replacement parts is not covered under this warranty. The manufacturer shall in no event pay mileage expenses or be responsible for down time or lost revenue.

**ABOUT YOUR WARRANTY**

This warranty covers only defects in material or workmanship. It does not cover damage from improper use or abuse, improper maintenance or repair, or normal wear and tear.

**Improper Use and Abuse** – The proper, intended use of the product is described in the Operator's Manual. Using the product in a manner not described in the Operator's Manual or continuing to use the product after it has been damaged will not be covered under this warranty. Warranty coverage also will not be provided if the serial number on the product has been removed, defaced, or altered, or if the product shows evidence of abuse, such as impact damage or water- or chemical-corrosion damage.

**Improper Maintenance or Repair** – This product must be maintained according to the procedures and schedules provided in the Operator's Manual, and serviced or repaired using original equipment parts or equivalent. Damage caused by lack of maintenance or use of non-original parts is not covered by warranty. The warranty does not extend to any failures resulting from unauthorized alterations, modifications, or other changes, or to damage resulting from improper installation, repair, operation, or maintenance. This exclusion does not apply to installations, repairs, or other work performed at the manufacturer's plant or under the manufacturer's direct supervision.

**Normal Wear and Tear** – Like most mechanical devices, this unit is subject to wear even when properly maintained. This warranty does not cover repair when normal use has exhausted the life of a part or the product. Maintenance and wear items such as filters, belts, tires, lamps, batteries, etc. are not covered by warranty, unless the cause of such wear is due to defects in material or workmanship directly related to those items.

**Other Exclusions** – This warranty excludes damages due to accident, abuse, modifications, alterations, improper servicing, or chemical deterioration. Attachments or accessories that were not originally installed in the product are also excluded. This warranty does not include used, reconditioned, second-hand, or demonstration equipment. This warranty also excludes failure due to acts of God and other force majeure events beyond the manufacturer's control.



# Allmand™

**BRIGHTER. WARMER. SAFER.**



[www.discount-equipment.com](http://www.discount-equipment.com)



*Reliability, performance, and integrity since 1938*

104819