

ENGINE

- Mitsubishi® L3E – liquid cooled, diesel engine
 - Standby - 12.2 hp @ 1800 rpm
 - Prime - 10.5 hp @ 1800 rpm
 - 0.95 L displacement, 3 cylinder
 - ECOSpeed™ EPA Final Tier 4 compliant multi-speed operation
- Polyethylene Fuel Tank:
 - Fuel Type: Diesel
 - Fuel Capacity: 104.0 gal (393.68 L)
 - External 3.5 in. (89 mm) fill port
- Fuel Consumption:
 - Lights Only: 0.195 gph (0.738 Lph)
 - Full Load: 0.549 gph (2.078 Lph)
 - Maximum Runtime (Lights Only): 530* hours
- Low fuel indicator beacon
- Cooling system allows operation to 120°F (49°C) ambient
- 100% containment of oil and coolant
- 1000-hour**service interval
- Full flow oil filter, spin on type
- Dry type cartridge air filter
- Wind Rating: 65 mph (105 kph)



**Results based on engine manufacturer and field test data after 100-hour engine break-in period and may vary based on factors including age and maintenance of equipment, environmental conditions and fuel density. Consult the Owner's Manual for fuel and maintenance recommendations.*

***To achieve maximum service interval, replacement of oil filter after 50-hour break-in period is required. Consult Owner's Manual for required oil filter model number.*

GENERATOR

- Marathon Electric®, Brushless
- 120/240 VAC – 50/25A
- +/-1% automatic voltage regulation

SYSTEM CONTROLS

- Power Zone™ Autolight controller
- Automated dusk to dawn or 7 day scheduler operation
- One touch manual starting
- Individual light fixture control
- Back-lit LCD display -40°F/C rated heated display.
- Three (3) Programmable service timers for Fuel Filter, Air Filter and Oil Service
- Alarms and comprehensive warnings
- Electrical trip or shutdown protection upon fault condition
- Key pad controlled electric mast optioned deployment

FLOODLIGHTS

- Four (4) 296W LED fixtures
- Efficiency: 145 lumens per watt
- Lumens per fixture: 43,050
- Total lumens: 172,200
- Coverage: 19,526 ft² (1,814 m²) at 0.5 ft-c
- IP68 LED modules; IP65 rated drivers
- Aluminum / Poly construction housing
- Fixture-mounted LED drivers
- 240Vac mast cord and fixtures

ELECTRICAL SYSTEM

- 30A Main Breaker with auxiliary speed control
- Dual floodlight switch circuits with 5A breakers
- Individually breakered convenience outlets:
- 120 VAC 20 Amp GFCI duplex outlets (NEMA 5-20R type)
- 240 VAC 30 Amp Twistlock outlets (NEMA L6-30R type)

MAST

- Vertical mast; 23 foot (7 m), 4-section with ground adjustable light fixtures
- Dual handle manual winch; electric winch optional
- 359° ground rotational mast with mast fully extended
- Industrial black powder coat finish with polymer guides

ENCLOSURE

- Aluminum Enclosure - .080" 5052
- UV & fade resistant, high temperature cured, white polyester powder paint
- 63 dB(A) @ 23 feet – low speed LED
- 68 dB(A) @ 23 feet – prime power
- Stainless steel hinges on doors
- Multi-lingual operating/safety decals
- License plate holder with light
- Manual holder with operating manual

TRAILER

- Tubular steel frame
- Four (4) 2000 lb. (907 kg) tube and sleeve leveling jacks
- Plated outriggers lock in position when deployed
- 7,800 lb. (3538 kg.) safety chains with spring loaded safety hooks
- Molded polyethylene fenders
- DOT approved tail, side, brake, and directional lights
- 3000 lb. (1361 kg) leaf spring axle
- 15 in. (38 cm) – 6 ply Tires
- 2 in. (50.8 mm) ball hitch with tandem tow receiver

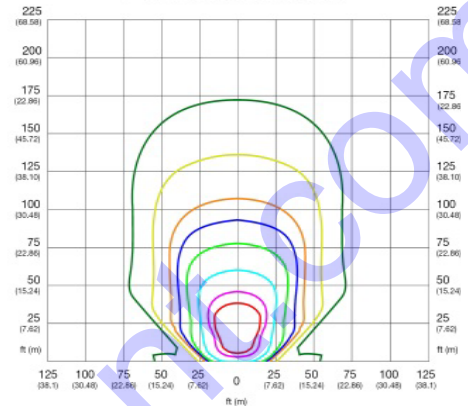

Area covered: 19,526 ft² (1,814 m²)
at minimum of 0.5 foot candles (ft-c)

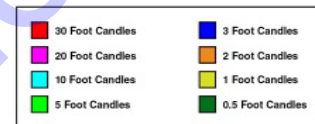

WEIGHT & DIMENSIONS

- Dry weight: 1694 lbs. (768 kg)
- Operating weight: 2770 lbs. (1256 kg)

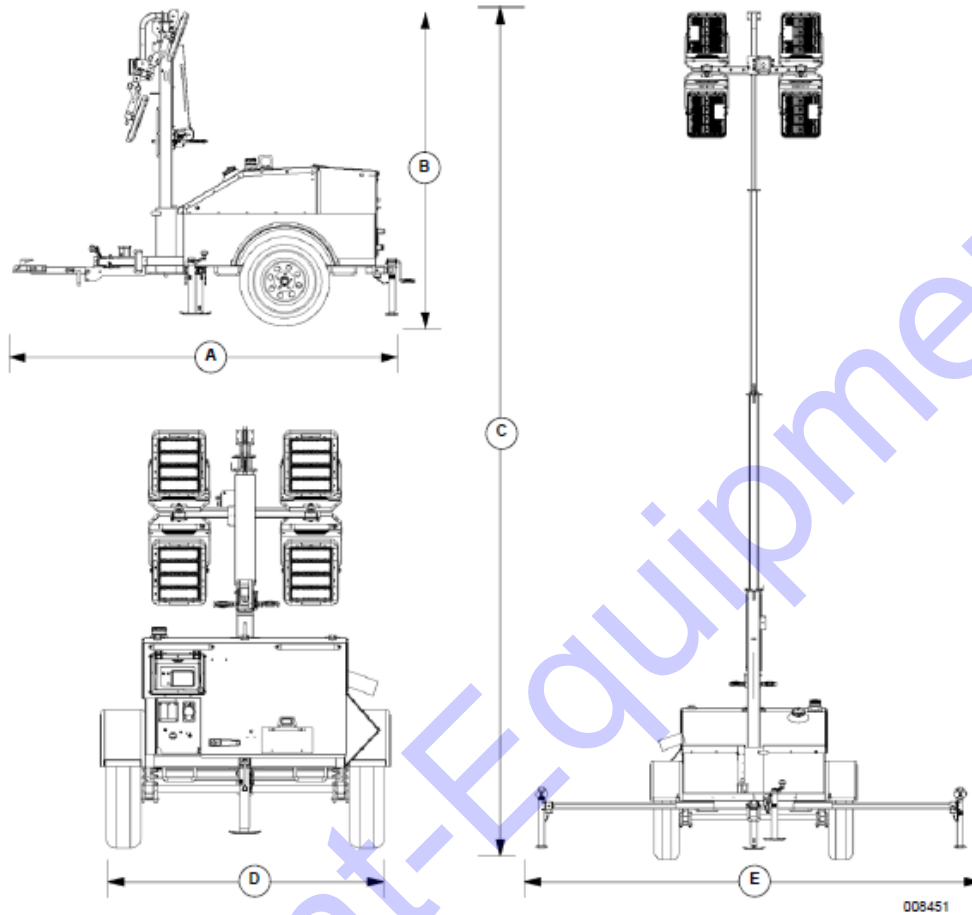

Figure 2-1. Unit Dimensions

	A	B	C	D	E
MLT4060MVD	124.5 in (316.23 cm)	101.2 in (257.05 cm)	23 ft (7 m)	68.2 in (173.23 cm)	144.8 in (367.80 cm)

Specifications are subject to change without notice.

WARRANTY

1 Year, Unlimited Hours / 2 Years, 2000 Hours on tower; 5 year limited warranty on LED modules and drivers

CERTIFICATIONS

CSA Approved