



# MAGNUM<sup>TM</sup>

POWER PRODUCTS LLC

## LIGHT TOWER

MLT4060MV • MLT4060KV

MLT4080KV

## OPERATING MANUAL

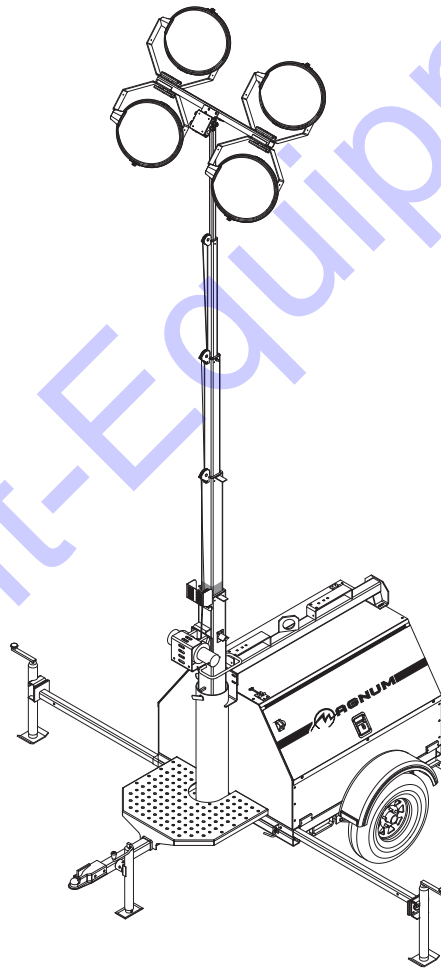

00121



[www.discount-equipment.com](http://www.discount-equipment.com)

# **Discount Equipment**

Discount-Equipment.com is your online resource for commercial and industrial quality parts and equipment sales.

## **Locations:**

Florida (West Palm Beach): [561-964-4949](tel:561-964-4949)

Outside Florida TOLL FREE: [877-690-3101](tel:877-690-3101)

**Need parts?** Check out our website at [www.discount-equipment.com](http://www.discount-equipment.com)

## **Can't find what you need?**

Click on this link: <http://www.discount-equipment.com/category/5443-parts/> and fill out the request form.

Please have the machine model and serial number available in order to help us get you the correct parts. One of our experienced staff members will get back to you with a quote for the right part that your machine needs.

We sell worldwide for the brands: Genie, Terex, JLG, MultiQuip, Mayco, Toro/Stone, Diamond Products, Magnum, Airman, Mustang, Power Blanket, Nifty Lift, Atlas Copco, Chicago Pneumatic, Allmand Brothers, Essick, Miller Spreader, Skyjack, Lull, Skytrak, Tsurumi, Husquvarna/Target, Whiteman-Concrete/Mortar, Stow-Concrete/Mortar, Baldor, Wacker, Sakai, Snorkel, Upright, Mi-T-M, Sullair, Neal, Basic, Dynapac, MBW, Weber, Bartell, Bennar Newman, Haulotte, Ditch Runner, Blaw-Knox, Himoina, Best, Buddy, Crown, Edco, Wyco, Bomag, Laymor, Terremite, Barreto, EZ Trench, Takeuchi, Basic, Bil-Jax, Curtis, Gehl, Heli, Honda, ICS/PowerGrit, Puckett, Waldon, ASV, IHI, Partner, Imer, Clipper, MMD, Koshin, Rice, Gorman Rupp, CH&E, Cat Pumps, Comet, General Pump, Giant, AMida, Coleman, NAC, Gradall, Square Shooter, Kent, Stanley, Tamco, Toku, Hatz, Kohler, Robin, Wisconsin, Northrock, Oztec, Toker TK, Rol-Air, Small Line, Wanco, Yanmar

**New Equipment - Used Equipment - Rental Equipment - Parts and Accessories**

# **Discount Equipment**

[www.discount-equipment.com](http://www.discount-equipment.com)

**561-964-4949**

Sales: [info@Discount-Equipment.com](mailto:info@Discount-Equipment.com)

Parts: [wbparts@Discount-Equipment.com](mailto:wbparts@Discount-Equipment.com)

## INTRODUCTION

This manual provides information and procedures to safely operate and maintain the Magnum Power Products LLC unit. For your own safety and protection from physical injury, carefully read, understand, and observe the safety instructions described in this manual. Keep a copy of this manual with the unit at all times. *The information contained in this manual was based on machines in production at the time of publication. Magnum Power Products LLC reserves the right to change any portion of this information without notice.*

Read all of the manuals included with the unit. Each manual details specific information regarding items such as setup, use and service requirements. An engine operator's manual provides detailed operation and maintenance procedures for the engine. Additional copies of the engine operator's manual are available from the engine manufacturer.

**DO NOT MODIFY** or use this equipment for any application other than which it was designed for.

Magnum Power Products LLC recommends that a trained and licensed professional perform all electrical wiring and testing functions. Any wiring should be in compliance with the National Electrical Code (NEC), state and local codes and Occupational Safety and Health Association (OSHA) guidelines.

Engine Make: \_\_\_\_\_

Engine Serial Number: \_\_\_\_\_

Engine Model Number: \_\_\_\_\_

Generator Make: \_\_\_\_\_

Generator Model Number: \_\_\_\_\_

Generator Serial Number: \_\_\_\_\_

Unit Model Number: \_\_\_\_\_

Unit Serial Number: \_\_\_\_\_

### **▲ WARNING**

**CALIFORNIA PROPOSITION 65 WARNING: Diesel engine exhaust and some of its constituents are known to the state of California to cause cancer, birth defects and other reproductive harm.**

# TABLE OF CONTENTS

	Page
INTRODUCTION .....	2
SAFETY NOTES .....	4
OPERATING SAFETY .....	4
ENGINE SAFETY .....	5
SERVICE SAFETY .....	6
TOWING SAFETY .....	6
REPORTING TRAILER SAFETY DEFECTS .....	7
SAFETY SYMBOL SUMMARY .....	8
SPECIFICATIONS - MLT4060MV, MLT4060KV .....	9
SPECIFICATIONS - MLT4080KV .....	10
UNIT DIMENSIONS .....	11
UNIT SERIAL NUMBER LOCATIONS .....	12
COMPONENT LOCATIONS .....	13
LIGHT TOWER SET UP .....	14
RAISING THE MAST .....	15
MAIN CONTROL PANEL - MLT4060MV, MLT4060KV .....	16
MAIN CONTROL PANEL - MLT4080KV .....	17
PRESTART CHECKLIST .....	18
STARTING THE UNIT .....	18
AUTOMATIC SHUTDOWN .....	19
LIGHT OPERATION .....	19
VOLTAGE REGULATION OPTION .....	19
DERATING FOR ALTITUDE .....	19
WET STACKING .....	20
CONTROL PANEL RECEPTACLES .....	20
SHUTTING DOWN THE UNIT .....	20
REMOVING THE LIGHTS FOR TRANSPORTATION .....	22
TOWING THE UNIT .....	22
LIFTING THE UNIT .....	23
GENERAL MAINTENANCE .....	24
BASIC MAINTENANCE SCHEDULE - MITSUBISHI ENGINE .....	25
BASIC MAINTENANCE SCHEDULE - KUBOTA ENGINE .....	26
WINCH USE, OPERATION & MAINTENANCE .....	27
JACK MAINTENANCE .....	27
TRAILER WHEEL BEARINGS .....	28
LOWER RADIATOR HOSE HEATER OPTION - USE AND MAINTENANCE .....	28
TROUBLESHOOTING THE LIGHTS .....	29
MAST LIGHT CONNECTIONS .....	30
AC WIRING DIAGRAM .....	31
DC WIRING DIAGRAM - MITSUBISHI ENGINE .....	32
DC WIRING DIAGRAM - KUBOTA ENGINE .....	33
DC WIRING DIAGRAM - ELECTRIC WINCH .....	34
DC WIRING DIAGRAMS FOR OPTIONAL EQUIPMENT .....	35
TRAILER LIGHTS WIRING DIAGRAM .....	36

## SAFETY NOTES



This is the safety alert symbol. It is used to alert you to potential personal injury hazards. Obey all safety messages that follow this symbol to avoid possible injury or death.

This manual contains DANGERS, WARNINGS, CAUTIONS, NOTICES and NOTES which must be followed to prevent the possibility of improper service, damage to the equipment, personal injury or death. The following formatting options will apply when calling the readers attention to the DANGERS, WARNINGS, CAUTIONS, NOTICES and NOTES.

### **▲ DANGER**

**INDICATES A HAZARDOUS SITUATION WHICH, IF NOT AVOIDED, WILL RESULT IN DEATH OR SERIOUS INJURY.**

### **▲ WARNING**

**Indicates a hazardous situation which, if not avoided, could result in death or serious injury.**

### **▲ CAUTION**

Indicates a hazardous situation which, if not avoided, could result in minor or moderate injury.

### **NOTICE**

Indicates a hazardous situation which, if not avoided, could result in property or equipment damage.

**Note:** Notes contain additional information important to a procedure and will be found within the regular text body of this manual.

## OPERATING SAFETY



Before using the unit be sure to read and understand all of the instructions provided with the unit. This equipment was designed for specific applications; **DO NOT** modify or use this equipment for any application other than which it was designed for. Equipment operated improperly or by untrained personnel can be dangerous.

Read the operating instructions and familiarize yourself with the location and proper use of all instruments and controls. Inexperienced operators should receive instruction from someone familiar with the equipment before being allowed to operate or set up the unit. The following points should be practiced at all times:

- The area immediately surrounding the unit should be dry, clean, and free of debris.
- Position and operate the unit on a firm, level surface.
- **NEVER** start a unit in need of repair.
- **ALWAYS** lower the mast when not in use, or if high winds or electrical storms are expected in the area.
- Make certain the unit is well grounded and securely fastened to a good earthen ground. Follow any local, state or National Electrical Code (NEC) guidelines.
- The mast extends up to 25 ft (7.6 m). **ALWAYS** make sure the area above the unit is open and clear of overhead wires and obstructions.
- Keep area around the mast clear of people while raising and lowering the mast.
- Keep all body parts, clothing and other loose items clear of the winch, cables and pulleys during operation.
- Bulbs become extremely hot during use. Allow them to cool 10-15 minutes before handling.
- **NEVER** raise or lower the mast while lights are in operation.

- **ALWAYS** extend the outriggers and level the unit before raising the mast. **DO NOT** retract the outriggers while the mast is up.
- If for any reason any part of the mast hangs up or the winch cable develops slack while raising or lowering the mast, **STOP** immediately and contact an authorized service representative.
- **NEVER** use the unit if insulation on the electrical cord is cut or worn through.
- **NEVER** operate the lights without protective lens covers in place or with a lens cover that is cracked or damaged.
- Only use mild soap and water to clean the lens covers. Other chemicals may have an adverse effect on the glass.
- **NEVER** operate a unit while tired, distracted, or under the influence of drugs or alcohol.

## ENGINE SAFETY



Internal combustion engines present special hazards during operation and fueling. Failure to follow the safety guidelines described below could result in severe injury or death. Also read and follow all safety warnings described in the engine operator's manual. A copy of this manual was supplied with unit when it was shipped from the factory.

- **DO NOT** run engine indoors or in an area with poor ventilation unless exhaust hoses are used. Diesel engine exhaust contains carbon monoxide, a deadly, odorless and colorless gas which, if inhaled, can cause nausea, fainting or death. Make sure engine exhaust cannot seep into closed rooms or ventilation equipment.
- **DO NOT** operate the unit on a combustible surface.
- **DO NOT** fill fuel tank near an open flame, while smoking, or while engine is running. **DO NOT** fill tank in an enclosed area with poor ventilation.
- **DO NOT** operate with the fuel tank cap loose or missing.
- **DO NOT** touch or lean against hot exhaust pipes or engine cylinders.
- **DO NOT** clean air filter with gasoline or other types of low flash point solvents.
- **DO NOT** remove engine coolant cap while engine is hot.
- **DO NOT** operate the unit without a functional exhaust system. Prolonged exposure to sound levels in excess of 85 dB(A) can cause permanent hearing loss. Wear hearing protection when working around a running engine.
- Keep area around exhaust pipes and air ducts free of debris to reduce the chance of an accidental fire.
- Batteries contain sulfuric acid which can cause severe injury or death. Sulfuric acid can cause eye damage, burn flesh or eat holes in clothing. Protective eye wear and clothing are necessary when working on or around the battery. Always disconnect the negative (-) battery cable from the corresponding terminal before performing any service on the engine or other components.
- Shut the engine down if any of the following conditions exist during operation:
  1. Noticeable change in engine speed.
  2. Loss of electrical output.
  3. Equipment connected to the generator overheats.
  4. Sparking occurs.
  5. Engine misfires or there is excessive engine/generator vibration.
  6. Protective covers are loose or missing.
  7. If the ambient air temperature is above 120°F (49°C).

## SERVICE SAFETY



This unit uses high voltage circuits capable of causing serious injury or death. Only a qualified electrician should troubleshoot or repair electrical problems occurring in this equipment.

- Before servicing, make sure the Engine Start switch is turned to OFF, circuit breakers are open (off) and the negative terminal on the battery is disconnected. **NEVER** perform even routine service (oil/filter changes, cleaning, etc.) unless all electrical components are shut down.
- **NEVER** allow water to accumulate around the base of the unit. If water is present, **DO NOT** service.
- **NEVER** service electrical components if clothing or skin is wet. If the unit is stored outside, check the engine and generator for any moisture and dry the unit before use.
- **NEVER** wash the unit with a power washer or high pressure hose.
- Open the main circuit breaker before disconnecting battery cables.
- Keep all body parts, clothing, and other loose items away from moving parts on the unit.
- Wear heavy leather gloves when handling winch cables. Never let cables slip through bare hands.
- Make sure slings, chains, hooks, ramps, jacks, and other types of lifting devices are attached securely and have enough weight-bearing capacity to lift or hold the unit safely. Always remain aware of the position of other people around when lifting the unit.

## TOWING SAFETY



Towing a trailer requires care. Both the trailer and vehicle must be in good condition and securely fastened to each other to reduce the possibility of an accident. Some states require that large trailers be registered and licensed, contact your local Department of Transportation office to check on license requirements for your particular unit.

- Check that the hitch and coupling on the towing vehicle are rated equal to, or greater than, the trailer's Gross Vehicle Weight Rating (GVWR).
- Check tires on trailer for tread wear, inflation, and condition.
- **NEVER** tow trailer using defective parts. Inspect the hitch and coupling for wear or damage.
- Make sure the trailer hitch and the coupling are compatible. Make sure the coupling is securely fastened to the vehicle.
- Connect safety chains in a crossing pattern under the tongue and **ATTACH THE BREAKAWAY CABLE TO THE REAR BUMPER OF THE TOWING VEHICLE**. Do not attach the cable to the trailer hitch.
- Make sure directional and brake lights on the trailer are connected and working properly.
- Check that all lug nuts holding wheels on are tight and none are missing.
- Maximum recommended speed for highway towing is 45 mph (72 km/h). Recommended off-road towing speed is not to exceed 10 mph (16 km/h) or less, depending on terrain.
- When towing, maintain extra space between vehicles and avoid soft shoulders, curbs and sudden lane changes. If you have not pulled a trailer before, practice turning, stopping, and backing up in an area away from heavy traffic.



## REPORTING TRAILER SAFETY DEFECTS

If you believe your trailer has a defect which could cause a crash or could cause injury or death, you should immediately inform the National Highway Traffic Safety Administration (NHTSA) in addition to notifying Magnum Power Products LLC.

If NHTSA receives similar complaints, it may open an investigation; and if it finds that a safety defect exists in a group of vehicles, it may order a recall and remedy campaign. However, NHTSA cannot become involved in an individual problem between you, your dealer, or Magnum Power Products LLC.

To contact NHTSA, you may either call the Auto Safety Hotline toll-free at 1-888-327-4236 (TTY:1-800-424-9153), go to <http://www.safercar.gov>; or write to:

















Administrator  
NHTSA  
1200 New Jersey Avenue S.E.  
Washington, DC 20590

You can also obtain other information about motor vehicle safety from <http://www.safercar.gov>.



## SAFETY SYMBOL SUMMARY

This equipment has been supplied with numerous safety and operating decals. These decals provide important operating instructions and warn of dangers and hazards. Replace any missing or hard-to-read decals and use care when washing or cleaning the unit. Decal placement and part numbers can be found in the parts manual. Below is a summary of the intended meanings for the symbols used on the decals.

	Safety alert symbol; used to alert you to potential personal injury hazards.		Asphyxiation hazard; operate in well ventilated area.
	Hot surface(s) nearby.		Dangerous voltage may be present.
	Belt/entanglement hazard; keep body parts clear of this area.		Anchor/tie down point.
	Fan hazard; keep body parts clear of this area.		Forklift here only.
	Crush hazard; keep body parts clear of this area.		Use clean diesel fuel only.
	Ultraviolet radiation hazard; operate only with lens intact.		Burn/scald hazard; pressurized steam.
	Stop engine before fueling.		Read and understand the supplied operator's manual before operating unit.
	Fire/explosion hazard; keep open flames away from unit.		Unit electrical ground.
	Lift here only.		

00198

## SPECIFICATIONS - MLT4060MV, MLT4060KV

MAGNUM MODEL	MLT4060MV	MLT4060KV
<b>Engine</b>		
Make/Brand.....	Mitsubishi .....	Kubota
Model .....	L3E-W461ML.....	D1005-E3BG1-MGM-1
EPA Tier .....	4f.....	4f
Type .....	Diesel, liquid cooled, 4-stroke.....	Diesel, liquid cooled, 4-stroke
Horsepower - prime <b>hp (kW)</b> .....	10.5 (7.8) .....	11.7 (8.7)
Horsepower - standby <b>hp (kW)</b> .....	12.2 (9.1) .....	13.1 (9.8)
Operating Speed <b>rpm</b> .....	1800.....	1800
Displacement <b>in<sup>3</sup> (L)</b> .....	57.97 (0.95) .....	61.08 (1.00)
Cylinders - qty .....	3.....	3
Fuel Consumption - 100% prime <b>gph (Lph)</b> .....	0.47 (1.78) .....	0.50 (1.89)
Battery Type - Group Number .....	24.....	24
Battery Voltage (Quantity per Unit) .....	12V (1).....	12V (1)
Battery Rating .....	440 CCA.....	440 CCA
<b>Generator</b>		
Make/Brand.....	Marathon Electric.....	Marathon Electric
Model .....	201CSA5411.....	201CSA5411
Type, Insulation .....	Brushless, F.....	Brushless, F
<b>Generator Set (Engine/Generator)</b>		
Output <b>kW (kVA)</b> .....	6.0 (6.0) .....	6.0 (6.0)
Output Voltage <b>V</b> .....	120/240, single phase.....	120/240, single phase
Output Amperes <b>120V (240V) A</b> .....	50 (25) .....	50 (25)
Frequency <b>Hz</b> .....	60.....	60
Power Factor.....	1 (1Ø).....	1 (1Ø)
<b>Weights</b>		
Dry Weight <b>lbs (kg)</b> .....	1759 (798) .....	1779 (807)
Operating Weight <b>lbs (kg)</b> .....	2162 (981) .....	2182 (990)
<b>Capacities</b>		
Fuel Tank Volume <b>gal (L)</b> .....	56 (212) .....	56 (212)
Usable Fuel Volume <b>gal (L)</b> .....	56 (212) .....	56 (212)
Coolant (incl. engine) <b>qt (L)</b> .....	4.5 (4.3) .....	4.8 (4.5)
Oil (incl. filter) <b>qt (L)</b> .....	3.8 (3.6) .....	5.4 (5.1)
Maximum Run Time <b>hrs</b> .....	119.....	112
<b>Lighting</b>		
Lighting Type.....	Metal Halide.....	Metal Halide
Ballast Type .....	Coil & Core .....	Coil & Core
Lumens .....	440,000.....	440,000
Coverage <b>acres (m<sup>2</sup>)</b> .....	5 - 7 (20,234 - 28,328).....	5 - 7 (20,234 - 28,328)
<b>AC Distribution</b>		
Circuit Breaker Size .....	30.....	30
Voltage Regulation .....	Capacitor +/-6%.....	Capacitor +/-6%
Voltages Available 1Ø.....	120, 240.....	120, 240
<b>Trailer</b>		
Number of Axles .....	1.....	1
Capacity - Axle Rating <b>lbs (kg)</b> .....	2200 (998) .....	2200 (998)
Tire Size <b>in</b> .....	13.....	13
Hitch - Standard .....	2" Ball .....	2" Ball
Maximum Tire Pressure <b>psi</b> .....	50.....	50

Specifications are subject to change without notice.

# SPECIFICATIONS - MLT4080KV

## MAGNUM MODEL

## MLT4080KV

### Engine

Make/Brand.....	Kubota
Model .....	D1105-E3BG
EPA Tier .....	4f
Type .....	Diesel, liquid cooled, 4-stroke
Horsepower - prime <b>hp (kW)</b> .....	13.5 (10.1)
Horsepower - standby <b>hp (kW)</b> .....	15.4 (11.5)
Operating Speed <b>rpm</b> .....	1800
Displacement <b>in<sup>3</sup> (L)</b> .....	68.53 (1.12)
Cylinders - qty .....	3
Fuel Consumption - 100% prime <b>gph (Lph)</b> .....	0.70 (2.65)
Battery Type - Group Number .....	24
Battery Voltage (Quantity per Unit) .....	12V (1)
Battery Rating .....	440 CCA

### Generator

Make/Brand.....	Marathon Electric
Model .....	201CSA5412
Type, Insulation .....	Brushless, F

### Generator Set (Engine/Generator)

Output <b>kW (kVA)</b> .....	8.0 (8.0)
Output Voltage <b>V</b> .....	120/240, single phase
Output Amperes <b>120V (240V) A</b> .....	66 (33)
Frequency <b>Hz</b> .....	60
Power Factor.....	1 (1Ø)

### Weights

Dry Weight <b>lbs (kg)</b> .....	1785 (810)
Operating Weight <b>lbs (kg)</b> .....	2188 (992)

### Capacities

Fuel Tank Volume <b>gal (L)</b> .....	56 (212)
Usable Fuel Volume <b>gal (L)</b> .....	56 (212)
Coolant (incl. engine) <b>qt (L)</b> .....	4.8 (4.5)
Oil (incl. filter) <b>qt (L)</b> .....	5.4 (5.1)
Maximum Run Time <b>hrs</b> .....	80

### Lighting

Lighting Type.....	Metal Halide
Ballast Type .....	Coil & Core
Lumens .....	440,000
Coverage <b>acres (m<sup>2</sup>)</b> .....	5 - 7 (20,234 - 28,328)

### AC Distribution

Circuit Breaker Size .....	40
Voltage Regulation .....	Capacitor +/-6%
Voltages Available 1Ø.....	120, 240

### Trailer

Number of Axles .....	1
Capacity - Axle Rating <b>lbs (kg)</b> .....	2200 (998)
Tire Size <b>in</b> .....	13
Hitch - Standard .....	2" Ball
Maximum Tire Pressure <b>psi</b> .....	50

*Specifications are subject to change without notice.*

# UNIT DIMENSIONS

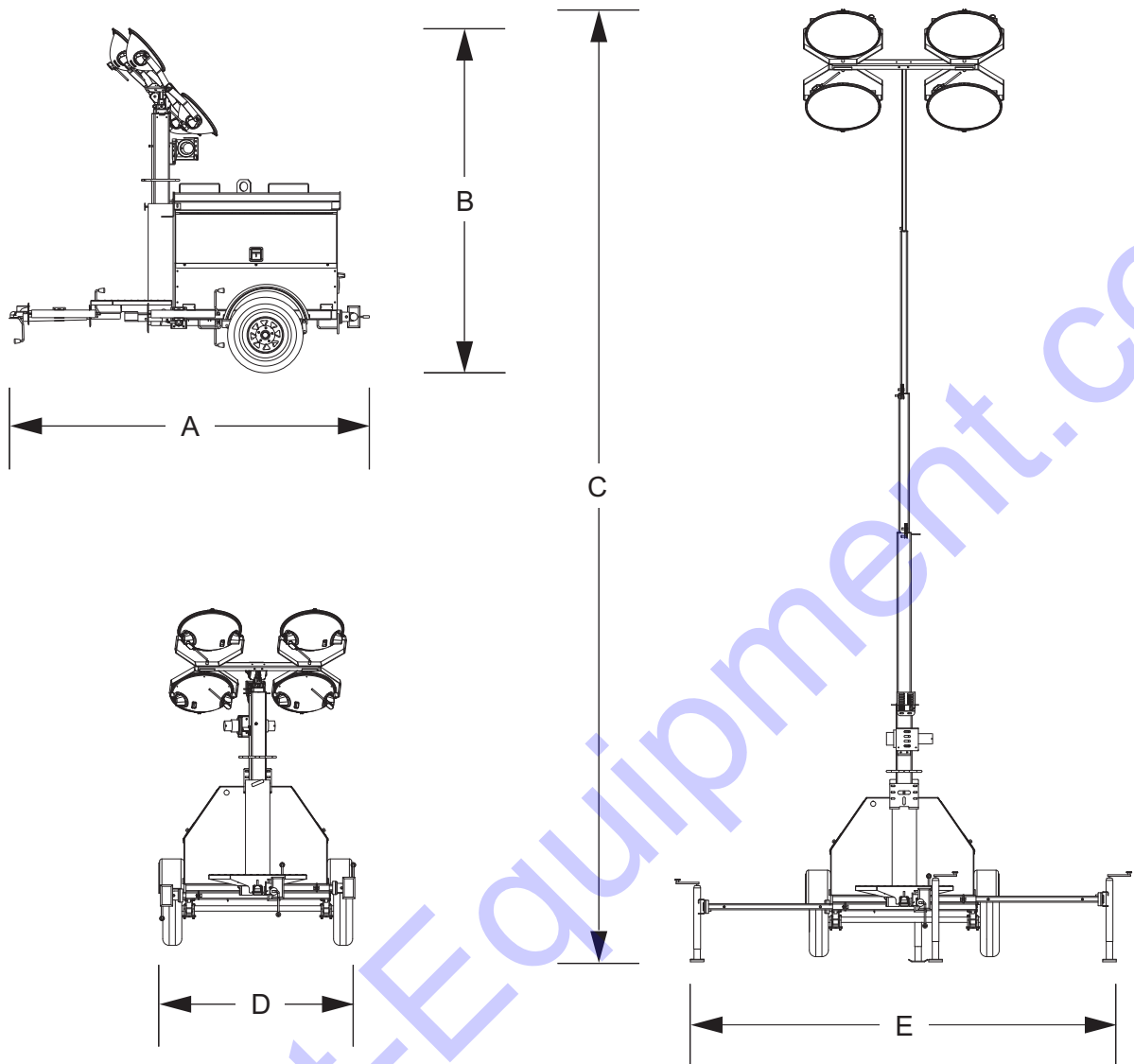

00213

	<b>A</b>	<b>B</b>	<b>C</b>	<b>D</b>	<b>E</b>
<b>MLT4060MV/KV, MLT4080KV</b>	115 in (2.92 m)	107 in (2.71 m)	25 ft (7.6 m)	68 in (1.73 m)	140 in (3.56 m)

Specifications are subject to change without notice.



# COMPONENT LOCATIONS

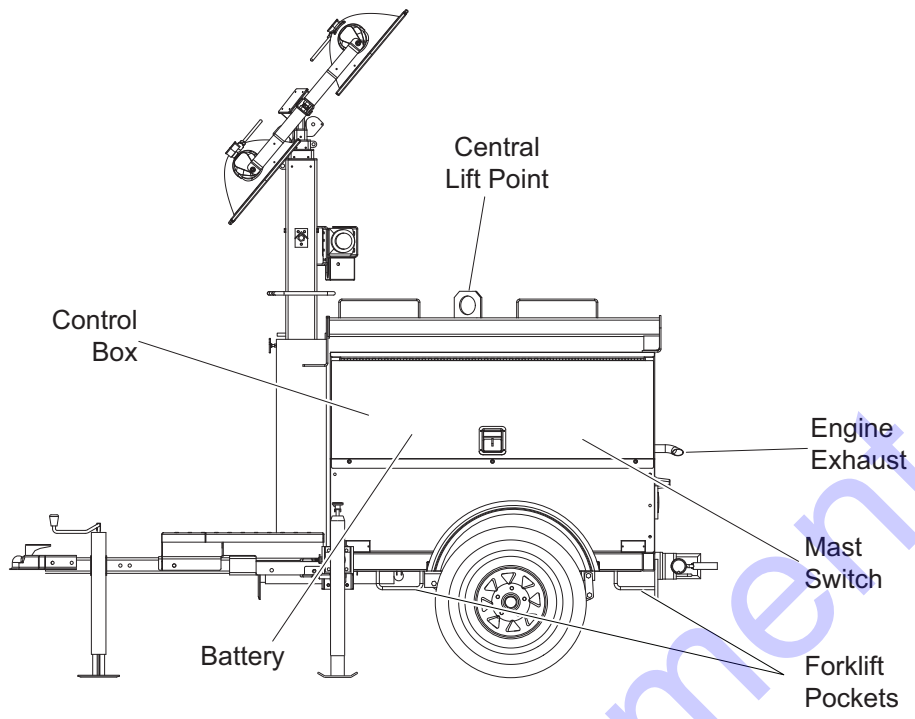

LEFT SIDE

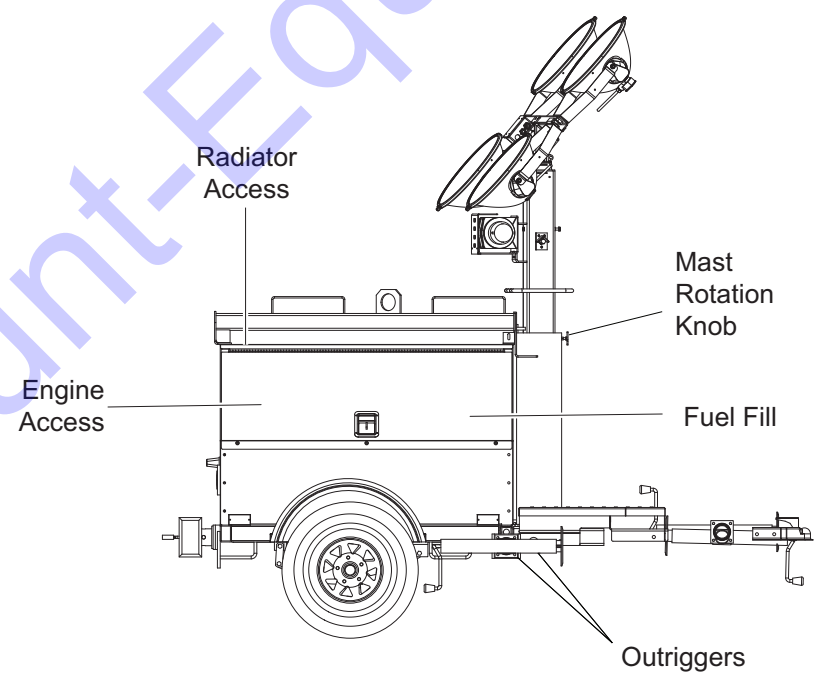

RIGHT SIDE

00109

## LIGHT TOWER SET UP

1. For maximum light coverage, locate the unit at ground level or in a spot higher than the area being illuminated by the lamps.

### ▲ WARNING

The mast extends up to 25 ft (7.6 m). Make sure area above the unit is open and clear of overhead wires and obstructions.

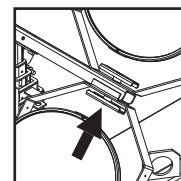
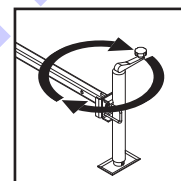
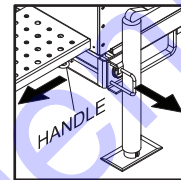
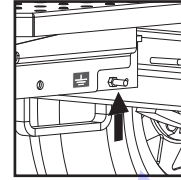
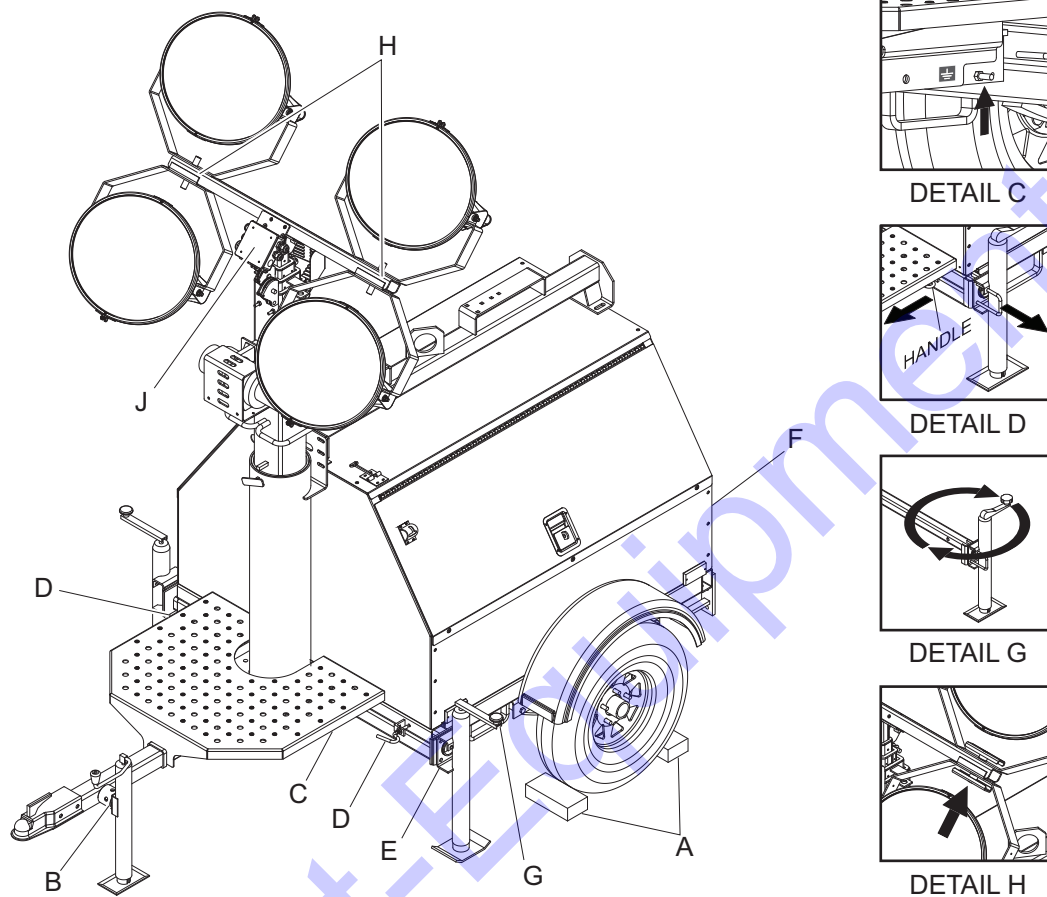

00156

2. Place the unit on firm ground that is relatively flat, then block the wheels to keep it from moving (A). This will make it easier to level the unit.
3. Pull the locking pin on the tongue jack and rotate the jack 90°. Replace the locking pin (B). Turn the jack handle clockwise to raise the trailer tongue off of the towing vehicle.
4. Connect a good earthen ground to the grounding stud on the frame of the trailer near the trailer tongue (C).

**Note:** Consult local codes for proper grounding requirements.

5. Pull the locking pin (D) on the outrigger (E) and pull each outrigger out until the spring loaded locking pin snaps back into place. Pull the locking pin on the outrigger jack and rotate each 90° so the jack pad is facing down and the spring loaded pin snaps back into place.
6. Pull the locking pin on the rear jack (F) and rotate the jack 90° until the spring loaded pin snaps back into place. Turn the jack handle clockwise to start leveling the trailer. Adjust all four jacks by turning their handles clockwise until they are firmly in contact with the ground and the trailer is as level as possible (G).
7. Before raising the mast, it may be necessary to adjust the lamps. The lamps may be adjusted up, down, left or right by loosening the wing nuts on the trunnion (H) and aiming them in the desired direction. Tighten the hardware completely and make sure the lamps are connected to the junction box (J).



## RAISING THE MAST

1. Set up and level the unit. Refer to *“Light Tower Set Up” on page 14.*

### ▲ WARNING

The unit must be leveled with the outriggers extended before raising the mast. The outriggers must remain extended while the mast is up. Failure to level the unit or extend the outriggers will severely reduce stability and could allow the unit to tip and fall.

2. Check the mast cables for excessive wear or damage. Make sure the cables are properly centered in each pulley (A). Check the electrical cord for damage.

### ▲ WARNING

Do not start the unit if insulation on the electrical cord is cut or worn through. Bare wires in contact with the mast or frame may energize the unit and cause electrocution. Repair or replace a damaged cord.

3. Press and hold the winch control toggle switch (B) upward to telescope the mast to the desired height. Extend the mast slowly, making sure that the coiled electrical cord is extending at the top sections of the mast. If, for any reason, the winch cable begins to develop slack or any of the mast sections get stuck, **STOP IMMEDIATELY** and contact an authorized service center.

### ▲ CAUTION

Do not extend the mast beyond the colored mark on top of the lower mast section (C). A limit switch on the main mast section will disconnect power to prevent overextending the mast.

4. The mast can be rotated by loosening the mast rotation knob at the bottom of the mast (D). Turn the mast until the lights face in the desired direction and then tighten the knob.

### ▲ WARNING

Never raise or lower the mast while the unit is operating.

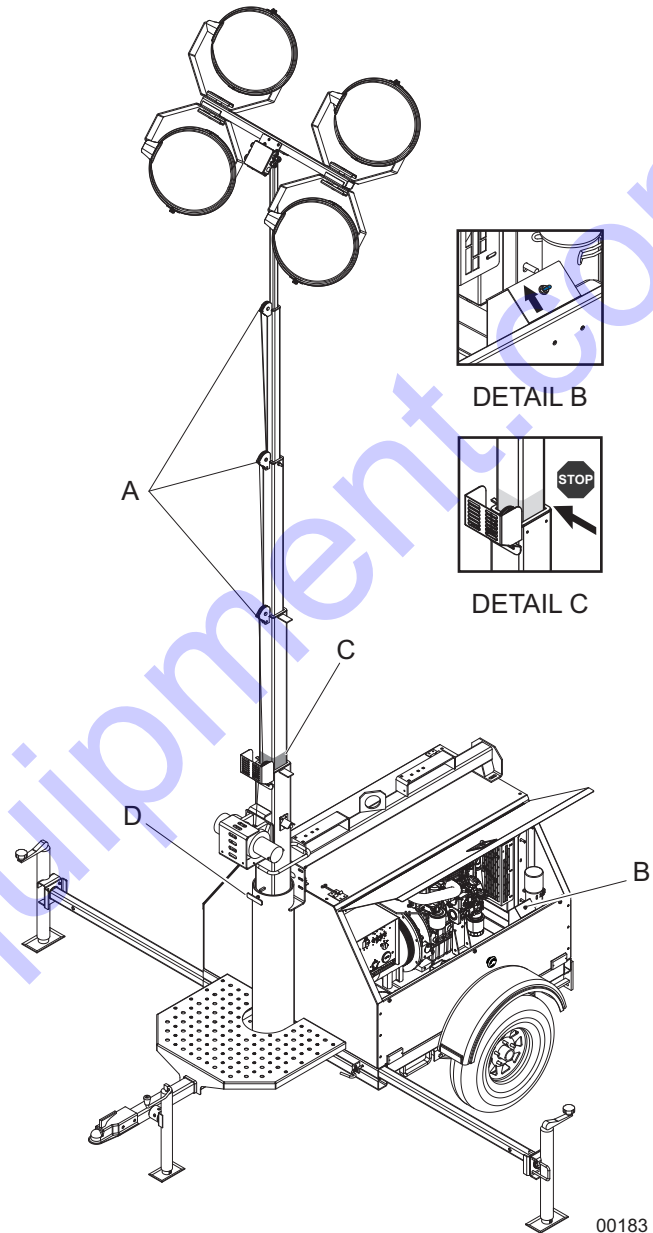

00183

## MAIN CONTROL PANEL - MLT4060MV, MLT4060KV

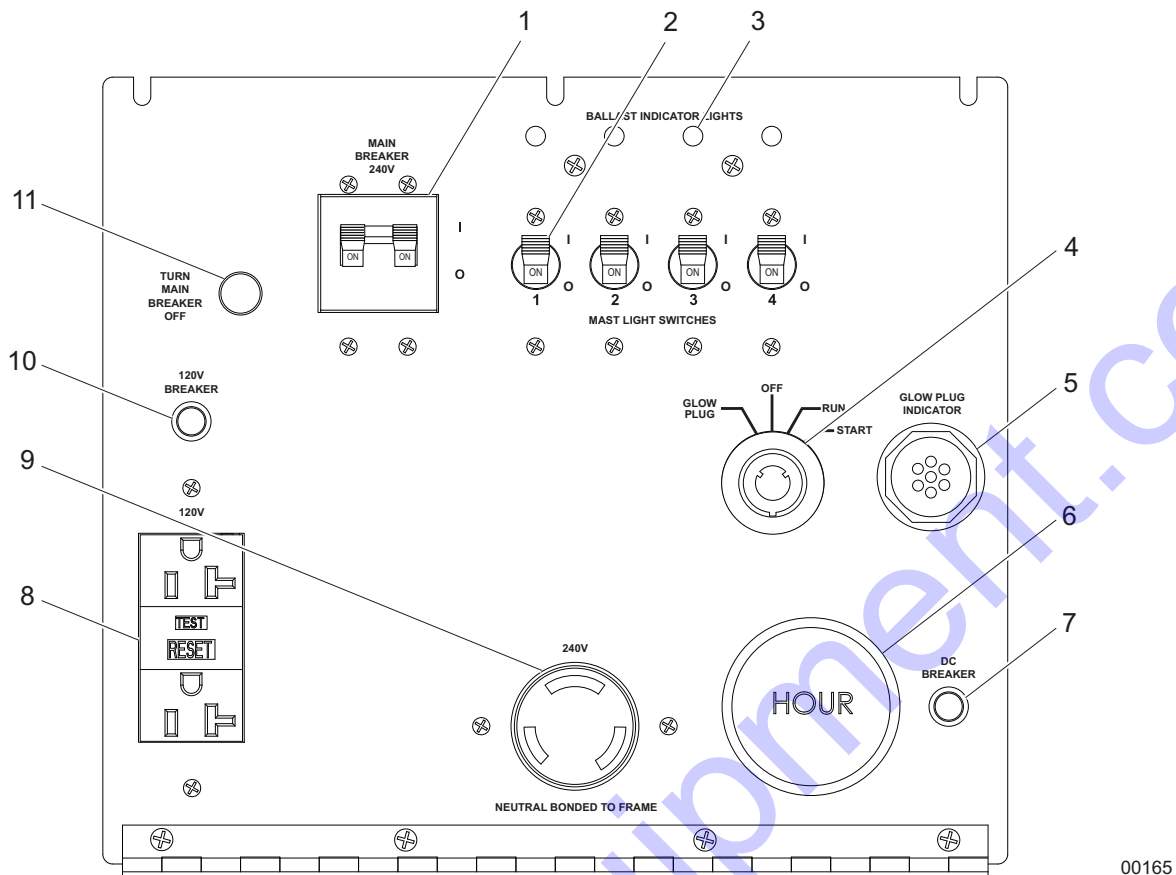

00165

1. **MAIN CIRCUIT BREAKER:** This 240V (30A) breaker will disconnect power to the lights and control panel receptacles.
2. **LIGHT SWITCHES:** One circuit breaker is supplied for each light.
3. **BALLAST INDICATOR LIGHTS:** Indicates power from the ballast to each light.
4. **ENGINE START SWITCH:** Keyed switch operates glow plugs, starts and stops engine.
5. **GLOW PLUG INDICATOR:** Indicates operation of the engine glow plugs (Mitsubishi engines only).
6. **ENGINE HOUR METER:** Keeps track of engine hours for service.
7. **DC BREAKER:** Circuit breaker (10A) for the engine electrical system.
8. **120V DUPLEX RECEPTACLE:** This unit is equipped with one 120V (20A) GFCI receptacle to supply power for accessories connected to the generator when the engine is running and the main circuit breaker is switched "ON/I".
9. **240V TWIST-LOCK RECEPTACLE:** This 240V (30A) receptacle supplies power for accessories connected to the generator when the engine is running and the main circuit breaker is switched to the "ON/I" position.
10. **120V BREAKER:** This 120V (20A) circuit breaker is supplied for the 120V GFCI duplex receptacle.
11. **CIRCUIT BREAKER INDICATOR LIGHT:** This light indicates that the main circuit breaker must be opened (switched off) before starting the engine.

## MAIN CONTROL PANEL - MLT4080KV

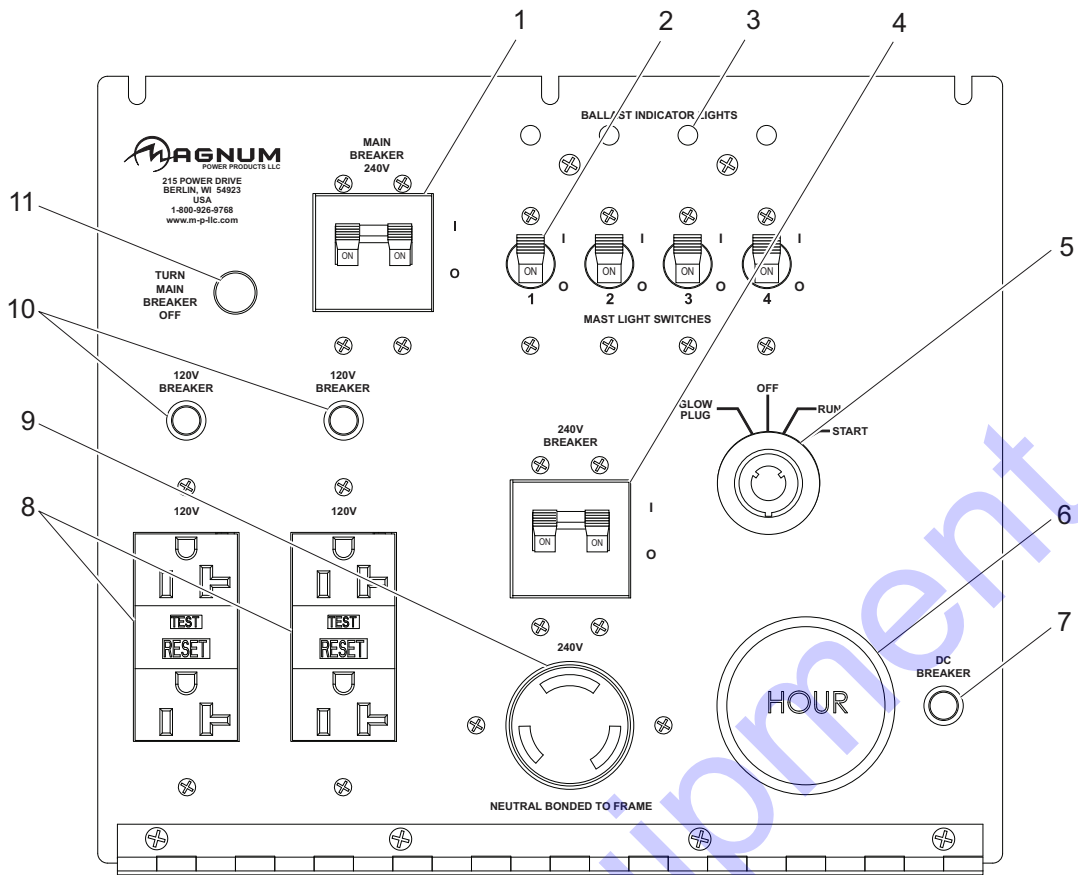

00166

1. **MAIN CIRCUIT BREAKER:** This 240V (40A) breaker will disconnect power to the lights and control panel receptacles.
2. **LIGHT SWITCHES:** One circuit breaker is supplied for each light.
3. **BALLAST INDICATOR LIGHTS:** Indicates power from the ballast to each light.
4. **240V BREAKER:** This 240V (30A) circuit breaker is supplied for the 240V twist-lock receptacle.
5. **ENGINE START SWITCH:** Keyed switch operates glow plugs, starts and stops engine.
6. **ENGINE HOUR METER:** Keeps track of engine hours for service.
7. **DC BREAKER:** Circuit breaker (10A) for the engine electrical system.
8. **120V DUPLEX RECEPTACLES:** This unit is equipped with two 120V (20A) GFCI receptacles to supply power for accessories connected to the generator when the engine is running and the main circuit breaker is "ON/I".
9. **240V TWIST- LOCK RECEPTACLE:** This 240V (30A) receptacle supplies power for accessories connected to the generator when the engine is running and both the main circuit breaker and 240V breaker are switched to the "ON/I" position.
10. **120V BREAKERS:** These 120V (20A) circuit breakers are supplied for the 120V GFCI duplex receptacles.
11. **CIRCUIT BREAKER INDICATOR LIGHT:** This light indicates that the main circuit breaker must be opened (switched off) before starting the engine.

# PRESTART CHECKLIST

Before starting the unit, all items in the prestart checklist must be completed.

- Read and understand **ALL** safety sections at the beginning of this manual.
- Ensure all maintenance procedures are up to date. For more information, refer to *“General Maintenance” on page 24* and Basic Maintenance Schedules beginning on *page 25*.
- The unit must be level.
- The unit must be dry. Check for any water inside, on, or near the unit, dry if needed.
- Ensure the unit is properly grounded to a good earthen ground. Installation should be in compliance with the National Electrical Code (NEC), as well as any state and local codes or regulations.
- Switch the “CONTROL ON/OFF” toggle switch to “OFF/O”.
- Switch all circuit breakers to “OFF/O”.
- Inspect all electrical cords; repair or replace any that are cut, worn, or bare.
- Ensure all winch cables are in good condition and centered on each pulley. Do not use if cables are kinked or beginning to unravel.
- Check oil, coolant, and fuel levels. For more information, refer to *“General Maintenance” on page 24*.
- Ensure engine battery connections are secure.
- Turn the battery disconnect switch on, if equipped.

## STARTING THE UNIT

1. Check that the main circuit breaker and individual circuit breakers for each of the lights are in the “OFF/O” position.

**Note:** When the red “TURN MAIN BREAKER OFF” light is illuminated, the main circuit breaker must be turned “OFF/O”.

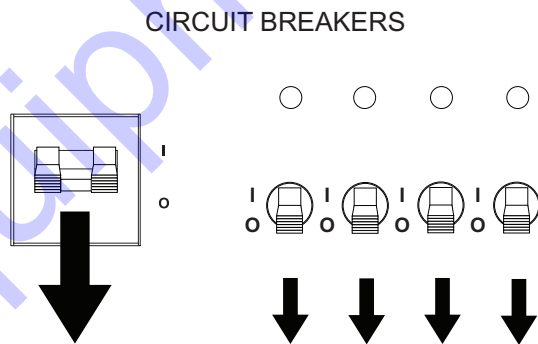

2. Turn the key on the Engine Start switch to the left “GLOW PLUG” position and hold the key in place for five seconds, or until the glow plug indicator turns red. (Kubota units do not have a glow plug indicator.) As soon as it is glowing, turn the key to the right “START” position and hold it until the engine cranks and starts running. Release the key, it will move to the “RUN” position.

**Note:** For cold weather conditions, refer to the engine operator’s manual for appropriate glow plug interval.

ACTIVATE GLOW PLUGS

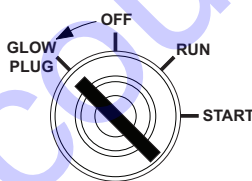

CRANK ENGINE TO START

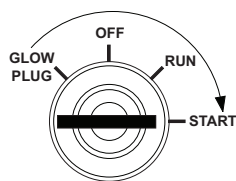

RELEASE KEY

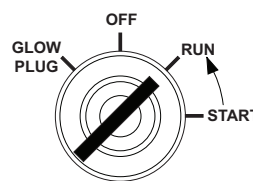

00203

### NOTICE

Do not crank the engine longer than 10 seconds at a time. If the engine will not start, wait 30 seconds to allow the starter motor to cool and then repeat the starting procedure. Excessive cranking will cause damage to the starter.

**Note:** If oil pressure is not obtained within 15 seconds after the key is switched to the “RUN” position, the low oil automatic shutdown will turn off the fuel supply, stopping the engine. Check the oil level and turn the key to the “OFF” position to reset the oil pressure timer before attempting to restart the engine.

3. Once the engine is running, allow it to reach normal operating temperature before switching on any loads.



## WET STACKING

The unit is powered by a diesel engine. Diesel engines are susceptible to wet stacking if lightly loaded. Wet stacking occurs when an engine is run at less than 30% of its full load capacity, causing unburned fuel to accumulate in the exhaust system. Wet stacking can be detected by continuous black exhaust when the unit is under a constant load. It can also cause fouling of injectors and buildup on engine valves. Diesel engines operate properly when applied loads are between 30% and 100% capacity. Appropriate generator sizing is determined by the anticipated load. If the unit is in a wet stack condition, load the unit heavily for five hours or until the exhaust is clear.

## CONTROL PANEL RECEPTACLES

Depending upon the model, the control panel is equipped with two or three receptacles for running accessories or tools from the generator. Power is supplied to the receptacles any time the engine is running and the main circuit breaker is switched "ON/I".

**Note:** Do not pull more than 1000W from each receptacle when the lights are on. This will overload the generator and cause the main circuit breaker to trip. Should the breaker trip, switch off the lights, remove some of the load to the receptacles and wait 10 minutes for the bulbs to cool before turning them back on.

With all of the lights off, the full generator output may be used with the optional 240V twist-lock receptacle.

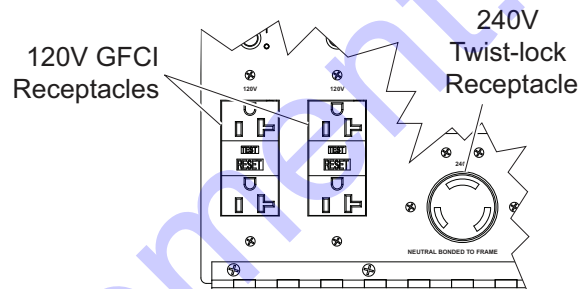

00114

## SHUTTING DOWN THE UNIT

Check with personnel using power supplied by the unit and let them know the power is going to be turned off. Make sure the power shut down will not create any hazards by accidentally turning off equipment that needs to be kept on (pumps, compressors, lights, etc.).

When you have finished using the unit, proceed with shut down as follows:

1. Remove any loads from the receptacles.
2. Switch the individual circuit breakers for each light to the "OFF/O" position.
3. Switch the main circuit breaker to the "OFF/O" position.
4. Turn the Engine Start switch to the "OFF" position.

CIRCUIT BREAKERS

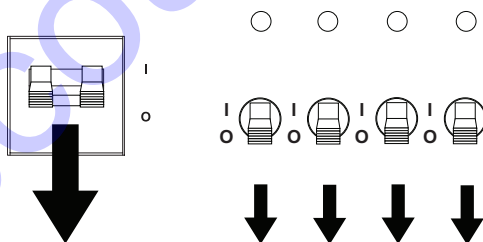

ENGINE START SWITCH

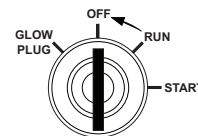

00201

**Note:** For extended storage time, disconnect the battery. For extended storage requirements, refer to the engine operator's manual.

## LOWERING THE MAST

### ELECTRICALLY LOWERING THE MAST

1. Shut down the lights and engine. Allow the lights to cool 10-15 minutes before lowering the mast.
2. If the trailer is going to be moved, it is recommended that the mast is turned so the lights face toward the back of the unit. To rotate the mast:
  - A. Loosen the mast rotation knob.
  - B. Rotate the mast until the white arrows are aligned and the metal stop tabs are touching. The winch and lights should be facing toward the back of the unit.
  - C. Tighten the mast rotation knob.
3. Press and hold the winch control toggle switch downward to collapse the mast to its lowest position. Ensure the electrical cord does not get caught in, or pinched by, the mast while it is being lowered.

### ▲ CAUTION

**STOP IMMEDIATELY** if the mast hangs up, or the winch cable begins to develop slack. Excess slack in the cable could cause the mast to collapse, which could result in personal injury or equipment damage. Contact an authorized service center.

**Note:** If the generator is not operational, and the batteries do not have enough power to lower the mast, it may be necessary to lower the mast manually.

**Note:** Magnum Power Products LLC strongly recommends that the lights be removed from the mast and stowed for transportation. Refer to [“Removing the Lights for Transportation” on page 22.](#)

### MANUALLY LOWERING THE MAST

### NOTICE

Do not use this procedure unless it is absolutely necessary. Continuous use of this procedure could damage the planetary gear brake of the winch. This procedure will not work if the planetary gear brake is damaged.

1. Remove the power cables from the two terminals on the winch motor assembly (A).
2. Remove the two flange head screws (B) securing the winch motor assembly to the winch. Retain the screws for reassembly.
3. Carefully remove the motor assembly (C), making sure the two pieces do not separate.
4. Insert a 3/8" allen head wrench (D) into the sleeve bearing.
5. Rotate the wrench counter-clockwise to lower the mast. If any slack is observed in the cable, stop immediately and remove the slack.
6. When the mast is completely down, reinstall the winch motor assembly, securing it with the screws retained in step 2.

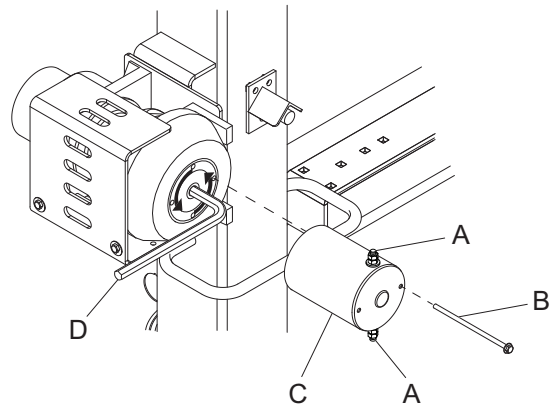



## REMOVING THE LIGHTS FOR TRANSPORTATION

1. On units equipped with quick disconnect fittings for the lights, disconnect the power cords from the junction box at the top of the mast. Replace the dust caps on the junction box. On hard wired units, remove the junction box cover, located on the top of the mast, and disconnect **ONLY** the mast light wires from the connectors. To release the mast light wires from the connectors, flip the locking levers down and pull out the appropriate wires.
2. Remove the lights by removing the wing nut that holds the light fixture bracket to the cross tube. Attach the lights to the storage brackets (if equipped) located on the mast tube on either side of the central lift point.

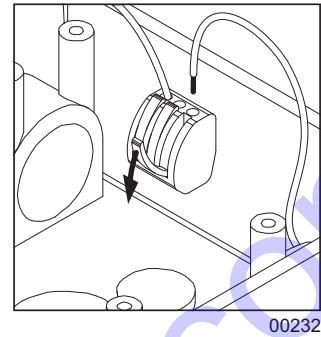

## TOWING THE UNIT

Once the engine is shut down and the mast and lights are properly stowed, follow these steps to prepare the unit for towing.

1. Raise the rear jack completely and release the locking pin to rotate it up into the travel position. Make sure the locking pin snaps into place.
2. Raise the outrigger jacks completely and release the jack locking pin to swing the jacks up into the travel position. Make sure the locking pins snap into place. Release the outrigger locking pins and slide the outriggers into the trailer frame until the locking pins snap into place.
3. Use the tongue jack to raise or lower the trailer onto the hitch of the towing vehicle. Lock the hitch coupling and attach the safety chains or cables to the vehicle. Remove the jack locking pin and rotate the jack into the travel position. Replace the locking pin.

**Note:** A film of grease on the coupler will extend coupler life and eliminate squeaking. Wipe the coupler clean and apply fresh grease each time the unit is towed.

4. To ensure proper operation of the jacks, lube the grease fittings located on the leveling jacks. Refer to “[Jack Maintenance](#)” on [page 27](#). For maintenance interval information, refer to Basic Maintenance Schedules beginning on [page 25](#).
5. Connect any trailer wiring to the tow vehicle. Check for proper operation of the stop and signal lights.
6. Make sure the mast cradle locking pin is in place.
7. Make sure the doors are properly latched.
8. If the unit is going to be driven over rough ground, remove the bulbs from the light fixtures.
9. Check for proper inflation of the trailer tires. Refer to Specifications beginning on [page 9](#).
10. Check the wheel lugs. Tighten or replace any that are loose or missing. If a tire has been removed for axle service or replaced, tighten the lugs, in the order shown, to the following specifications:

- A. Start all lug nuts by hand.
- B. First pass tighten to 20-25 ft-lbs (27-33 Nm).
- C. Second pass tighten to 50-60 ft-lbs (67-81 Nm).
- D. Third pass tighten to 90-120 ft-lbs (122-162 Nm).

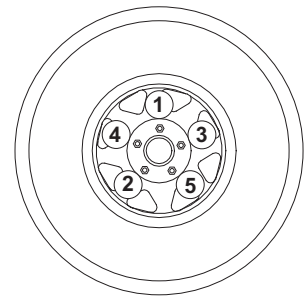

**Note:** After the first road use, re-torque the lug nuts in sequence.

11. Maximum recommended speed for highway towing is 45 mph (72 km/h). Recommended off-road towing speed is not to exceed 10 mph (16 km/h) or less, depending on the terrain.

## LIFTING THE UNIT

When lifting the unit, attach any slings, chains or hooks directly to the central lift point. The central lift point is located on the mast between the two forklift pockets.

1. Make sure the equipment being used to lift the unit has sufficient capacity. For approximate weights, refer to Specifications beginning on [page 9](#).
2. Always remain aware of people and objects around the unit while moving.
3. Use the upper or lower forklift pockets with care. Approach the unit as perpendicular as possible to avoid any damage to the unit. Make sure the mast winch handles or any other obstructions are clear of the forklift tines before lifting.

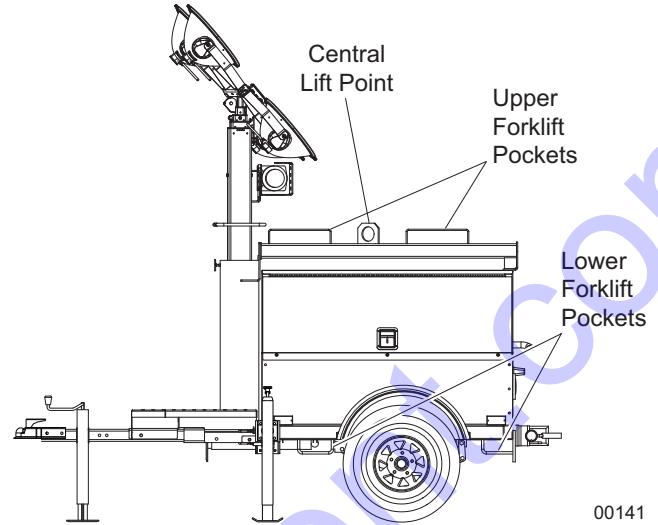

00141

## GENERAL MAINTENANCE

Poorly maintained equipment can become a safety hazard. In order for the equipment to operate safely and properly over a long period of time, periodic maintenance and occasional repairs are necessary. **NEVER** perform routine service (oil/filter changes, cleaning, etc.) unless all electrical components are shut off. Before servicing the unit, always follow the instructions listed below.

- Ensure the Engine Start switch is turned to the “OFF/O” position.
- Ensure the circuit breakers are open, “OFF/O”.
- Disconnect the negative (-) terminal on the battery.
- Attach a “DO NOT START” sign to the control panel. This will notify everyone that the unit is being serviced and will reduce the chance of someone inadvertently trying to start the unit.
- Never wash the unit with a high pressure hose or with any kind of power washer.
- Never wash the engine block or fuel tank with a power washer or steam cleaner. Water may enter the cabinet and collect in the generator windings or other electrical parts, causing damage.
- If the unit is stored outside, check for water inside the cabinet and generator before each use. If wet, dry the unit thoroughly before starting.
- Inspect condition of electrical cords. **DO NOT** use the unit if insulation is cut or worn through.
- Check that winch cables are in good condition and are centered on each pulley. **DO NOT** use a cable that is kinked or starting to unravel.
- Check the wheel lugs. Refer to *“Towing the Unit” on page 22.*
- Check coolant levels. Refer to the engine operator’s manual when determining proper mixture.
  - Coolant is checked visually by inspecting the level in coolant overflow jug near the radiator.
  - Normal operation is between the “FULL” and “ADD” markings on the overflow jug, this is known as “Normal Range.”
  - **WHEN ENGINE IS STOPPED AND COMPLETELY COOL**, coolant may be added directly to the jug .
- Check the oil levels. Refer to the engine operator’s manual when determining proper viscosity.
  - **DO NOT** start the unit if the engine oil level is below the “ADD” mark on the dipstick.
  - Normal operation is between the “FULL” and “ADD” markings on the dipstick.
  - Add oil only if oil level is below cross-hatch pattern on the dipstick. **DO NOT OVERFILL** crankcase.
- Check fuel level.

PROPER MAST  
CABLE ROUTING

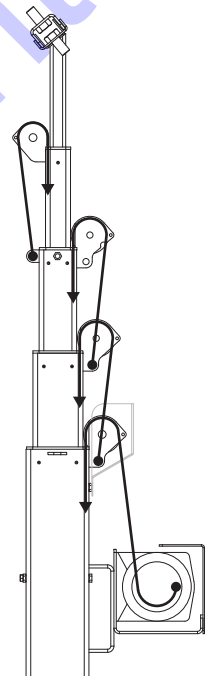

00132

**Note:** If the engine was run out of fuel or the fuel tank was drained, it may be necessary to bleed the fuel lines. Refer to the engine operator’s manual supplied with the unit.

## BASIC MAINTENANCE SCHEDULE - MITSUBISHI ENGINE

### NOTICE

Refer to the original equipment manufacturer's operating manual for a complete list of maintenance requirements. Failure to comply with the procedures as described in the engine operator's manual will nullify the warranty, decrease performance and cause equipment damage or premature equipment failure. Maintenance records may be required to complete a warranty request.

Use the schedule in the following table as a guide for regular maintenance intervals. For additional or replacement copies of the engine operator's manual, contact an authorized dealer in your area.

Item	Daily	50 Hours	250 Hours	400 Hours	500 Hours	1000 Hours	As Required
Check Oil Level	◆						
Check Coolant Level	◆						
Check Fuel Level	◆						
Check Tire Pressure	◆						
Check All Electrical Connections	◆						
Inspect Radiator Fins For Debris, Clean As Required	◆						
Inspect Light Tower Winch For Proper Operation	◆						
Fuel Tank - Drain Water		◆					
Check Air Cleaner		◆					
Replace Engine Oil And Oil Filter			◆*				
Belt And Belt Tension - Inspect And Adjust			◆				
Replace Fuel Filter				◆			
Drain And Clean Fuel Tank					◆**		
Check Glow Plugs					◆		
Lubricate Leveling Jacks					◆		
Bolts And Nuts On The Engine - Retighten						◆*	
Replace Heated Fuel Filter (If Equipped)						◆	
Inspect Engine Starting Battery						◆	
Air Cleaner Element - Clean, Check And Replace							◆
Fuel System - Bleed Air							◆
Water Sedimenter - Drain Water							◆

\* Perform after the initial 50 hours of operation, then on the regularly scheduled interval indicated in the schedule above.

\*\* Certain conditions may require the fuel tank to be drained and cleaned more often. When operating in extremely dusty conditions, clean the fuel tank as often as necessary.

## BASIC MAINTENANCE SCHEDULE - KUBOTA ENGINE

### NOTICE

Refer to the original equipment manufacturer's operating manual for a complete list of maintenance requirements. Failure to comply with the procedures as described in the engine operator's manual will nullify the warranty, decrease performance and cause equipment damage or premature equipment failure. Maintenance records may be required to complete a warranty request.

Use the schedule in the following table as a guide for regular maintenance intervals. For additional or replacement copies of the engine operator's manual, contact an authorized dealer in your area.

Item	Daily	50 Hours	100 Hours	200 Hours	400 Hours	500 Hours	1 Year
Check Oil Level	◆						
Check Coolant Level	◆						
Check Fuel Level	◆						
Check Tire Pressure	◆						
Check All Electrical Connections	◆						
Inspect Radiator Fins For Debris, Clean As Required	◆						
Inspect Light Tower Winch For Proper Operation	◆						
Check Fuel Pipes And Clamp Bands		◆					
Clean Air Cleaner Element			◆				
Clean Fuel Filter			◆				
Check Fan Belt Tightness			◆				
Drain Water Separator			◆				
Check Radiator Hoses And Clamp Bands				◆			
Change Engine Oil				◆*			
Check Intake Air Line				◆			
Replace Oil Filter Cartridge					◆*		
Replace Fuel Filter Cartridge					◆		
Clean Water Separator					◆		
Lubricate Leveling Jacks						◆	
Remove Sediment In Fuel Tank						◆	
Replace Fan Belt						◆	
Replace Air Filter Element							◆**

\* Change the engine oil and oil filter after the initial 50 hours of operation, then at the appropriate interval thereafter.

\*\* Replace the air cleaner element yearly, or after six cleanings, whichever occurs first.

## WINCH USE, OPERATION & MAINTENANCE

- Keep winch free of dirt, oil, grease, water and other substances.
- Check all mounting bolts and make sure they are tightened to the recommended torque values. Replace any damaged fasteners.
- Periodically check all connections to be sure they are tight and free of corrosion.
- Check cable for visible damage every time winch is operated. Examples of damage are: cuts, knots, mashed or frayed portions, and broken strands. Replace cable immediately if damaged. Failure to replace a damaged cable could result in breakage.
- Regularly check brake for slippage or drift. This is detected visually when winch is under load. If winch drum continues to turn after controls are released, the brake may need to be replaced.
- Periodically clean and grease brake assembly. This will ensure proper performance and extend the life of the winch. If winch seems to labor or get excessively hot during the lowering of loads, the brake will need to be serviced or replaced.
- Check motor brushes periodically and replace when necessary.

**Note:** Only the motor brushes and brake assembly require periodic replacement.

### PREVENTIVE MAINTENANCE SCHEDULE

Maintenance Activity	After First Operation	Before Each Use	Semi-Annually Or After Each 25 Hours Of Operation
Check Fasteners	◆		◆
Check Electrical Connections	◆		◆
Clean And Grease Brake Assembly			◆
Check Motor Brushes			◆
Visually Check Winch And Control	◆	◆	◆

### MECHANICAL BRAKE

The mechanical brake generates heat when loads are lowered and the wire cable is powered out. Care must be taken to avoid overheating the mechanical brake.

Whine or chatter associated with a new mechanical brake is normal and typically disappears with use.

Overheating the mechanical brake may result in permanent damage to, or failure of, the brake. Replace any damaged brake components before resuming use of the winch.

### JACK MAINTENANCE

The following procedures should be performed at least annually.

#### SIDE-WIND MODELS

- The internal gearing and bushings of the jack must be kept lubricated. Apply a small amount of automotive grease to the internal gearing by removing the jack cover, or if equipped, use a needle nose applicator or standard grease gun on the lubrication point found on the side of the jack near the crank. Rotate the jack handle to distribute the grease evenly.
- A lightweight oil must be applied to the handle unit at both sides of the tube.
- If equipped, the axle bolt and nut assembly of the caster wheel must also be lubricated with the same lightweight oil.

## TOP-WIND MODELS

- Apply a lightweight oil to the screw stem.

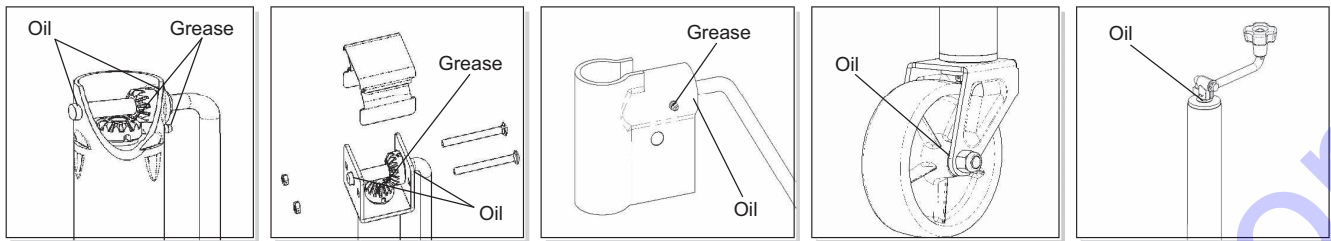

## TRAILER WHEEL BEARINGS

The trailer axles are equipped with a grease zerk fitting to allow lubrication of the wheel bearings without the need to disassemble the axle hub. To lubricate the axle bearings, remove the small rubber plug on the grease cap, attach a standard grease gun fitting to the grease zerk fitting and pump grease into the fitting until new grease is visible around the nozzle of the grease gun. Use only a high quality grease made specifically for lubrication of wheel bearings. Wipe any excess grease from the hub with a clean cloth and replace the rubber plug when finished. The minimum recommended lubrication is every 12 months or 12,000 miles (19,312 km). More frequent lubrication may be required under extremely dusty or damp operating conditions.

## LOWER RADIATOR HOSE HEATER OPTION - USE AND MAINTENANCE

### ⚠ CAUTION

Improper use of the lower radiator hose heater could result in damage to the engine or personal injury. Do not modify the location of the lower radiator hose heater.

The following points should be followed when operating a unit equipped with a lower radiator hose heater.

- Ensure the cooling system is full of the proper mixture of water and engine coolant before each heater use.
- The heater is designed for all-night operation, however, 2-5 hours of heating just prior to starting is usually sufficient for proper engine starting.
- The unit must be level to maintain proper orientation of the heater while it is in operation.
- Use only an undamaged, outdoor rated, three-prong grounded 120VAC extension cord with a minimum amperage rating of 10A. Connect the cord to a properly grounded 120VAC, GFCI receptacle.
- Before starting the engine, unplug the extension cord from the power first, then unplug the heater cordset from the extension cord.



## TROUBLESHOOTING THE LIGHTS

### **⚠ DANGER**

**THIS UNIT USES HIGH VOLTAGE CIRCUITS CAPABLE OF CAUSING SERIOUS INJURY OR DEATH. ONLY A QUALIFIED ELECTRICIAN SHOULD TROUBLESHOOT OR REPAIR ELECTRICAL PROBLEMS OCCURRING IN THIS EQUIPMENT.**

#### MAST LIGHTS OFF BUT BALLAST INDICATORS ON CONTROL PANEL ARE ON

1. Mast light is too hot. Allow light to cool 10-15 minutes before restarting.
2. Faulty bulb connection. Check that the bulb is tight in the socket.
3. Bulb broken. Check for broken arc tube or outer bulb jacket, broken or loose components in bulb envelope or blackening/deposits inside tube.
4. Check the connections inside the mast junction box and each mast light housing/socket.
5. Check the mast electrical cord for damage and check the cord connections inside the control box.

#### MAST LIGHTS OFF AND BALLAST INDICATORS ON CONTROL PANEL ARE OFF

1. Check the connections inside the control box and inside each ballast box.
2. Generator output incorrect. Check the incoming voltage to the ballast by checking the available voltage on the duplex receptacle. Incoming voltage should be 120V +/- 5V. If voltage is incorrect, the engine speed may need to be adjusted or generator may require service.
3. Low transformer output. The voltage from the transformer should read approximately 400VAC as the light "strikes" (induces an arc), then drop and slowly rise back up to stabilize at 240-260VAC. On quick disconnect models, measure across the junction box terminals when the light is unplugged. On hard wired models, remove the mast junction box cover and insert the wire probes into the connector blocks for the light and ground. If proper voltage is not achieved, perform capacitor check to determine if the capacitor or coil needs to be replaced.

#### MAST LIGHTS ON BUT THE LIGHT OUTPUT IS LOW

1. Fixture or lens are dirty. Clean reflective surface inside fixture and both inside and outside surface of glass lens. Use mild soap and water to clean lens. Other chemicals may have an adverse effect on the glass.
2. Bulb worn due to normal use. Replace bulb.
3. Check the mast coil cord, mast junction box and mast light connections.
4. Generator output incorrect. Check the incoming voltage to the ballast. Incoming voltage should be 120V +/- 5V. If voltage is incorrect, engine speed may need to be adjusted or generator may require service.
5. Low transformer output. The voltage from the transformer should read approximately 400VAC as the light "strikes" (induces an arc), then drop and slowly rise back up to stabilize at 240-260VAC. On quick disconnect models, measure across the junction box terminals when the light is unplugged. On hard wired models, remove the mast junction box cover and insert the wire probes into the connector blocks for the light and ground. If proper voltage is not achieved, perform capacitor check to determine if the capacitor or coil needs to be replaced.

# MAST LIGHT CONNECTIONS

## MAST JUNCTION BOX WIRING 4-LIGHT

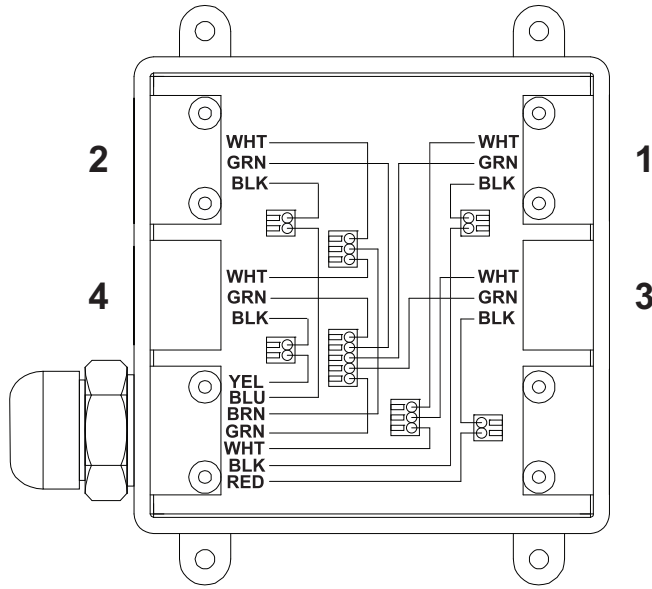

## MAST LIGHT CONNECTIONS 4-LIGHT

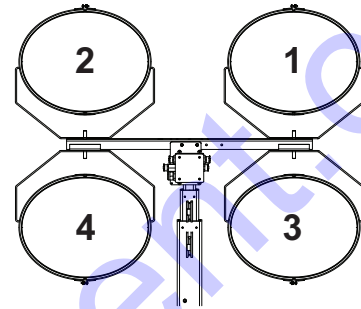

00175

# AC WIRING DIAGRAM

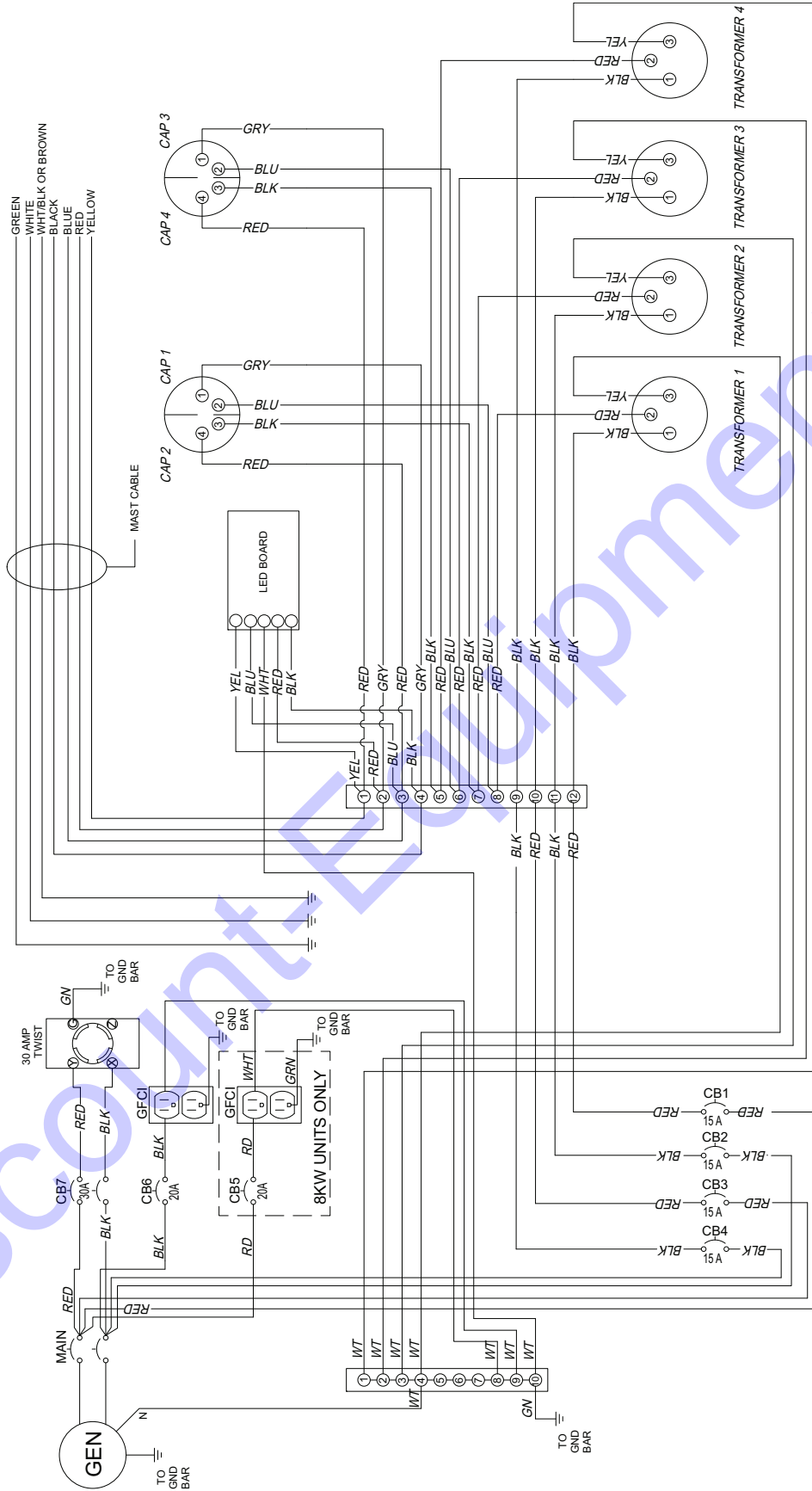

90347\_C\_12.02.13

# DC WIRING DIAGRAM - MITSUBISHI ENGINE

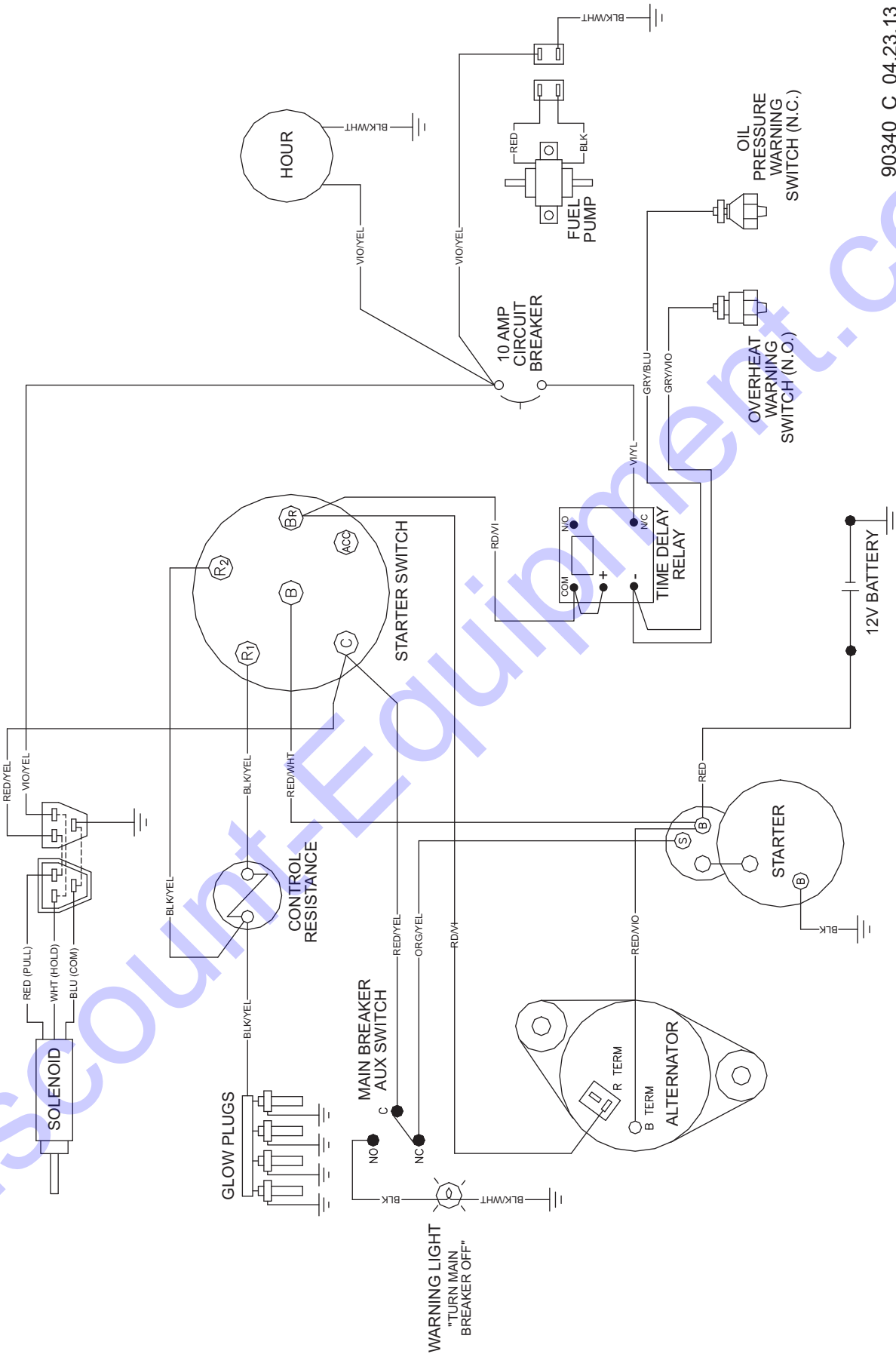

90340\_C\_04.23.13

# DC WIRING DIAGRAM - KUBOTA ENGINE

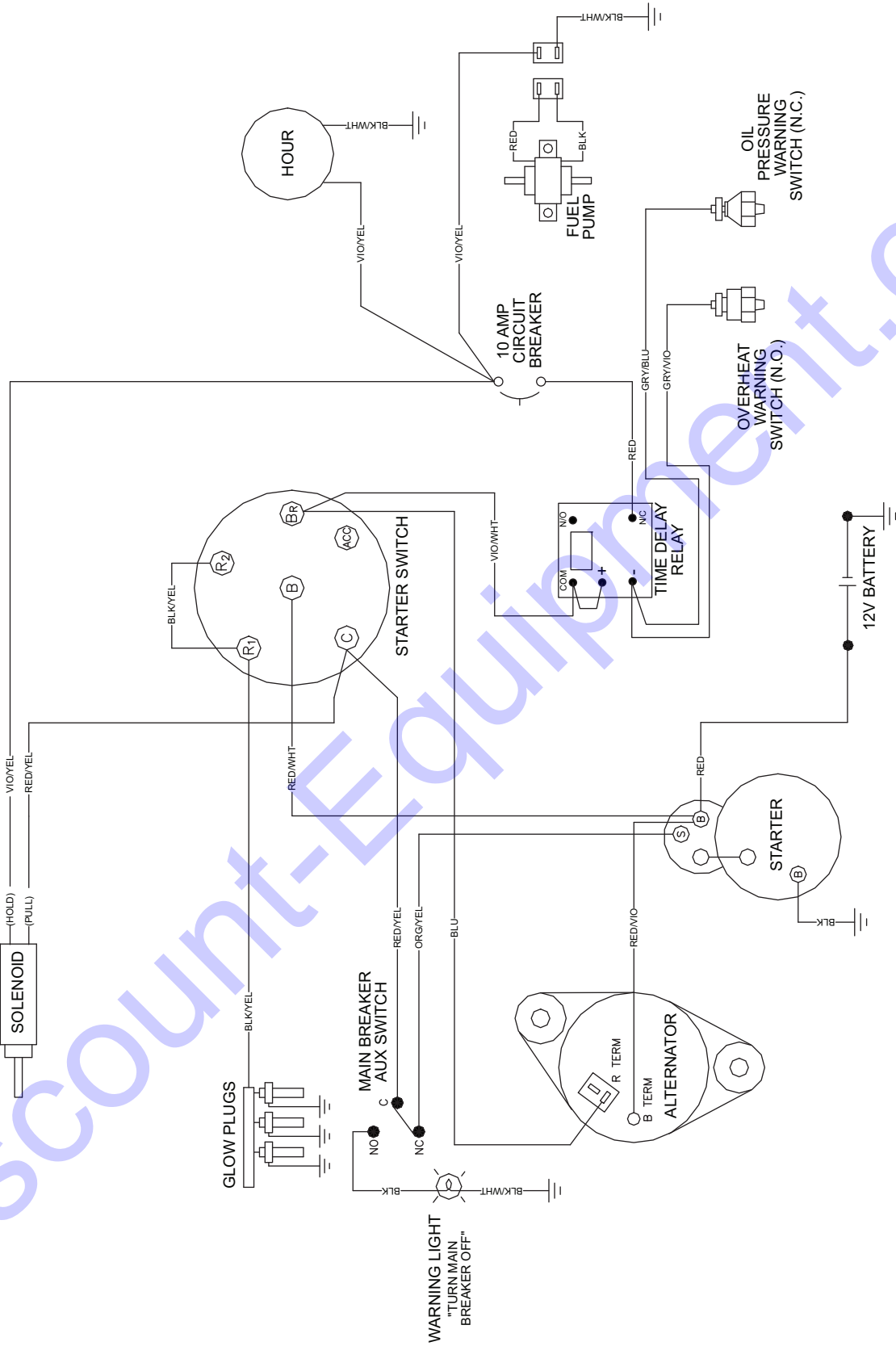

90339\_D\_09.10.13



# DC WIRING DIAGRAMS FOR OPTIONAL EQUIPMENT

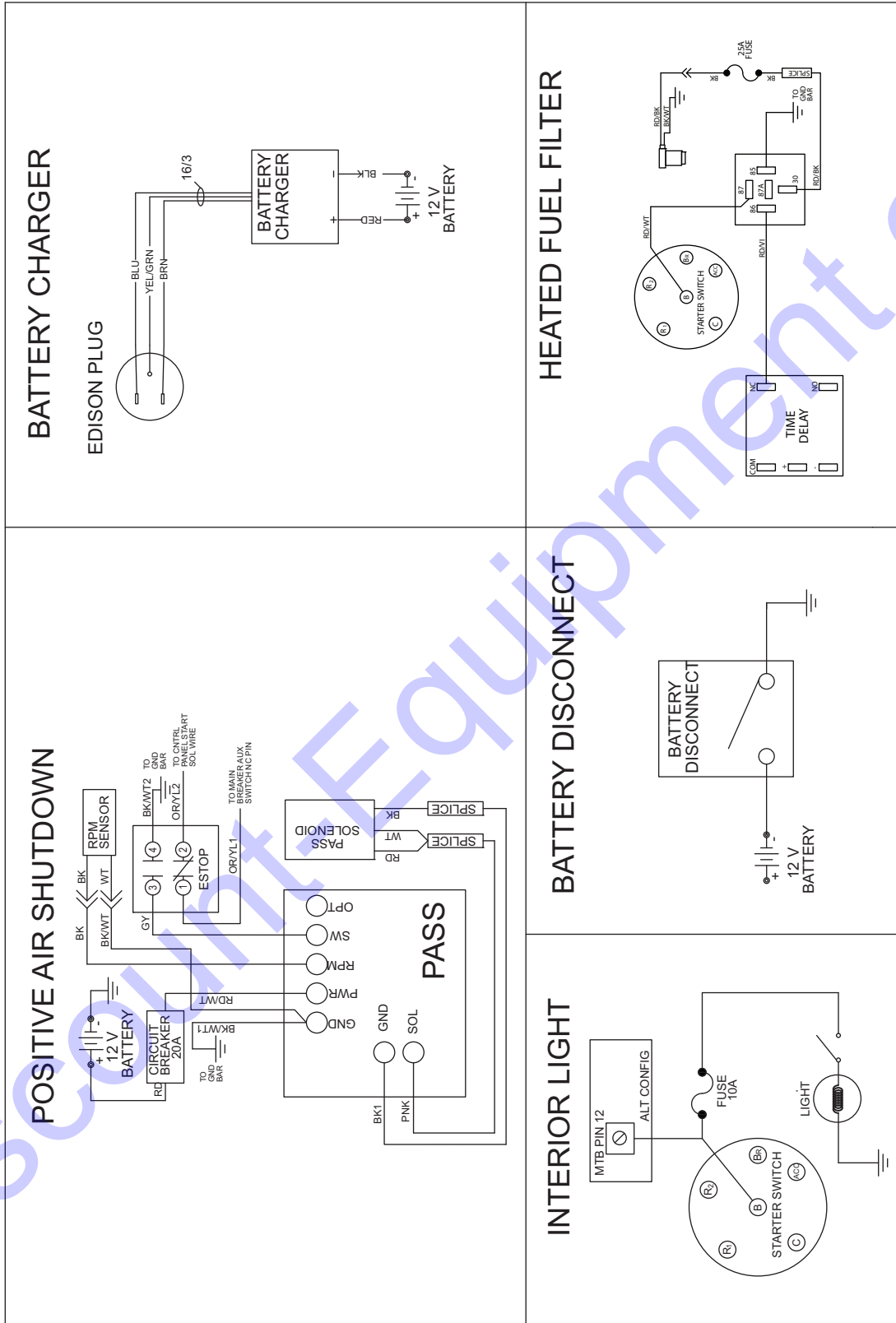

90323\_I\_11.18.13



# TRAILER LIGHTS WIRING DIAGRAM

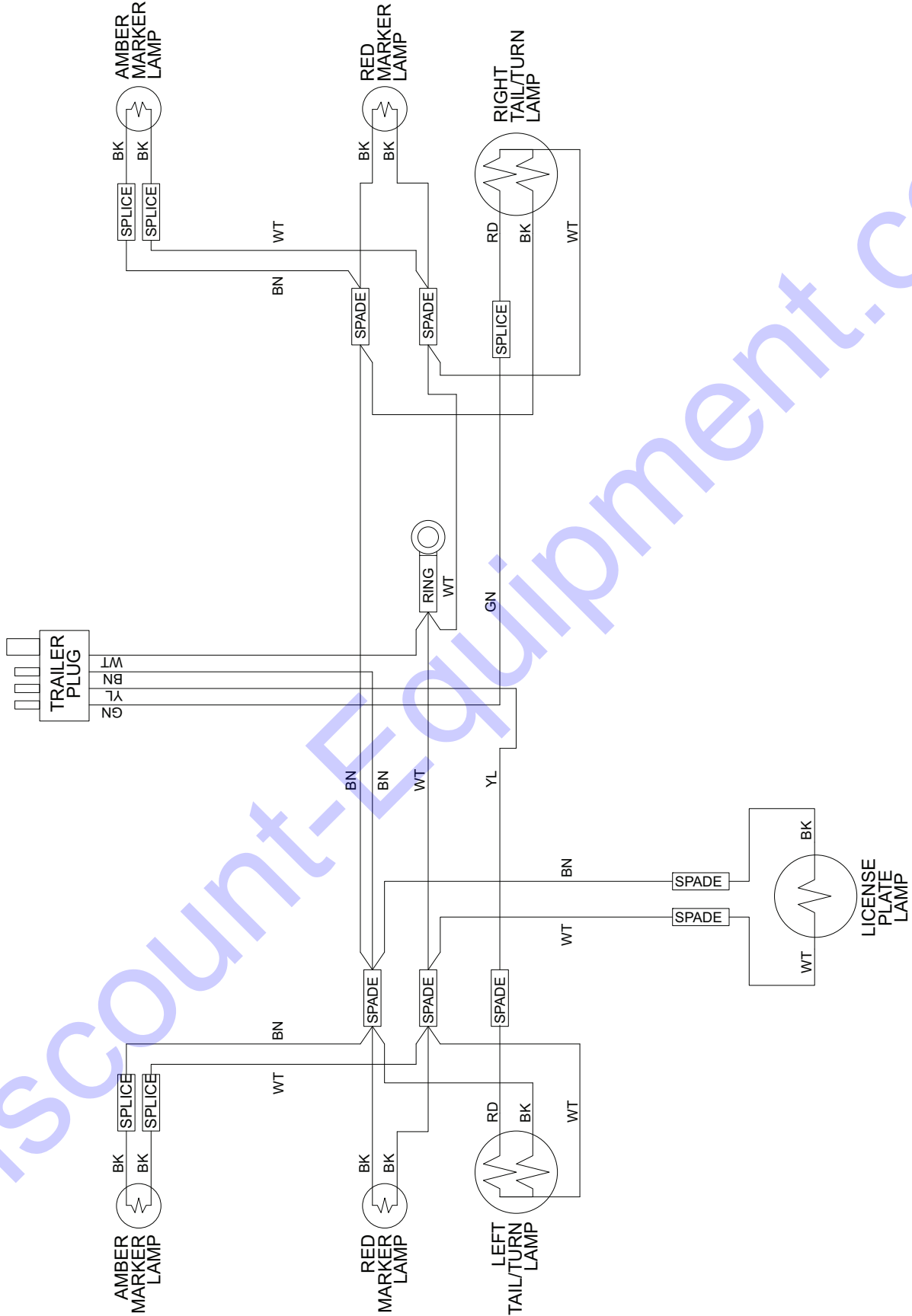

90341\_B\_12.20.13



[www.discount-equipment.com](http://www.discount-equipment.com)

REV: C  
PART NO: 33298  
01.10.14