



# OPERATOR MANUAL

**MODELS: 1050PM, 1265PM, 1285PM &  
1650PM**



## PLASTER/MORTAR MIXER

A 100% employee-owned American manufacturer

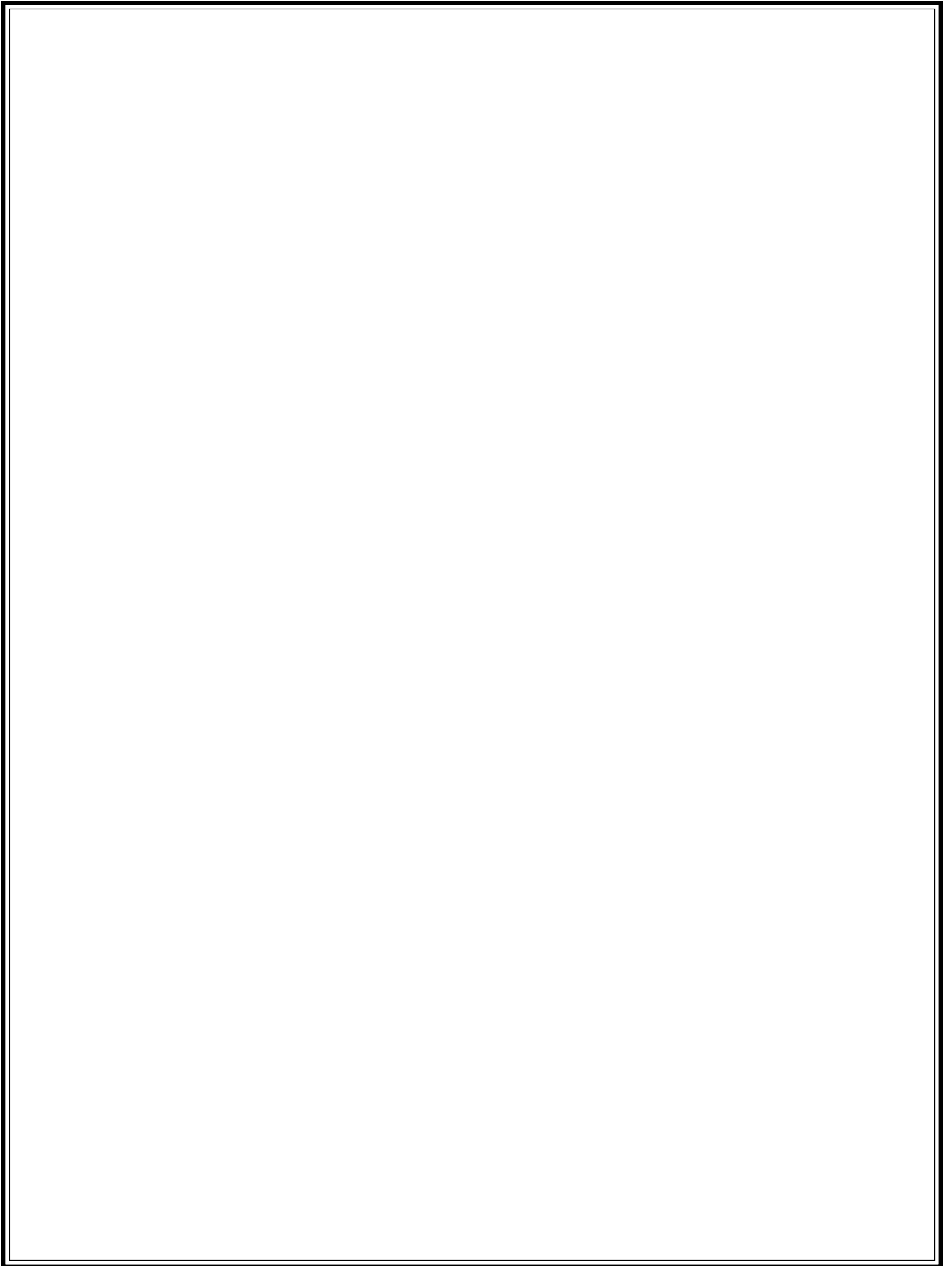

# Table of Contents

1050PM, 1265PM, 1285PM  
& 1650PM

|  |              |
|--|--------------|
| <b>TABLE OF CONTENTS</b> .....         | <b>3</b>     |
| <b>FOREWORD</b> .....                  | <b>4</b>     |
| <b>LIMITED WARRANTY</b> .....          | <b>5</b>     |
| <br>                                   |              |
| <b>TECHNICAL DATA</b> .....            | <b>6-9</b>   |
| Machine Data .....                     | 6            |
| Torque Chart - Imperial .....          | 7            |
| Torque Chart - Metric .....            | 8            |
| Hardware Identification .....          | 9            |
| <br>                                   |              |
| <b>HEALTH &amp; SAFETY</b> .....       | <b>10-14</b> |
| Safety Training .....                  | 10           |
| Safety Precautions .....               | 11-14        |
| <br>                                   |              |
| <b>INTRODUCTION</b> .....              | <b>15-18</b> |
| Intro .....                            | 15           |
| Operating Principle .....              | 15           |
| Delivery Checks .....                  | 15           |
| Before Starting .....                  | 15           |
| Determining the Right Machine .....    | 15           |
| Standard Features .....                | 16           |
| Preparation for Service .....          | 16           |
| Before Starting .....                  | 16-17        |
| Hardware .....                         | 18           |
| Fuel .....                             | 18           |
| Location and Use of Controls .....     | 18           |
| <br>                                   |              |
| <b>OPERATIONS</b> .....                | <b>19-20</b> |
| To Start .....                         | 19           |
| To Stop .....                          | 19           |
| Initial Operation .....                | 20           |
| <br>                                   |              |
| <b>MAINTENANCE</b> .....               | <b>21-24</b> |
| Before Towing .....                    | 21           |
| Maintenance and Lubrication .....      | 22           |
| Maintenance Chart .....                | 23           |
| Cleaning .....                         | 24           |
| <br>                                   |              |
| <b>CALIFORNIA PROPOSITION 65</b> ..... | <b>IBC</b>   |

# User Information

## Foreword

These instructions include:

- Safety regulations
- Operating instructions
- Maintenance instructions

**These instructions have been prepared for operation on the construction site and for the maintenance engineer.**

These instructions are intended to simplify operation of the machine and to avoid malfunctions through improper operation.

Observing the maintenance instructions will increase the reliability and service life of the machine when used on the construction site and reduce repair costs and down-times.

**Always keep these instructions at the place of use of the machine.**

**Only operate the machine as instructed and follow these instructions.**

**Observe the safety regulations as well as the guidelines of the civil engineering trade association. Observe safety rules for the operation of equipment and the pertinent regulations for the prevention of accidents.**

Stone Construction Equipment, Inc. is not liable for the function of the machine when used in an improper manner and for other than the intended purpose.

Operating errors, improper maintenance and the use of incorrect operating materials are not covered by the warranty.

The above information does not extend the warranty and liability conditions of business of Stone Construction Equipment, Inc.

1. Machine Type: \_\_\_\_\_

Machine S/N: \_\_\_\_\_

2. Engine Type: \_\_\_\_\_

Engine S/N: \_\_\_\_\_

3. VIN: \_\_\_\_\_

4. Purchase Date: \_\_\_\_\_

5. Dealer/Distributor Information:

Name: \_\_\_\_\_

Address: \_\_\_\_\_

\_\_\_\_\_

Phone #: \_\_\_\_\_

Fax #: \_\_\_\_\_

6. Battery  
Manufacturer: \_\_\_\_\_

Battery Type: \_\_\_\_\_

Battery S/N: \_\_\_\_\_

*Location of above information:*

1. Information on S/N tag.
2. Information on engine tag.
3. Information on S/N tag - if applicable.
4. Date you purchased machine.
5. Dealer machine was purchased from.
6. Information on battery and battery warranty card.

Stone Construction Equipment, Inc.  
P.O. Box 150, Honeoye, New York 14471  
Phone: (800) 888-9926

## Limited Warranty

The Manufacturer warrants that products manufactured shall be free from defects in material and workmanship that develop under normal use for a period of 90 days for concrete vibrators and electric pumps, one year for Rhino®, Bulldog®, WolfPac Rollers™, trowels, Stompers®, saws, forward plates, engine powered pumps, Lift Jockey™, Mortar Buggy™ and 6 months for all other products from the date of shipment. The foregoing shall be the exclusive remedy of the buyer and the exclusive liability of the Manufacturer. Our warranty excludes normal replaceable wear items, i.e. gaskets, wear plates, seals, O-rings, V-belts, drive chains, clutches, etc. Any equipment, part or product which is furnished by the Manufacturer but manufactured by another, bears only the warranty given by such other manufacturer. (The Manufacturer extends the warranty period to "Lifetime" for the drum bearings and seals for the mortar mixers, and agrees to furnish, free of charge, the bearings and seals only upon receipt of the defective parts. The warranty is two years for eccentric bearings on the forward plate compactors, mortar and plaster mixer drums, trowel gearboxes and five years on the Bulldog trench roller eccentric bearings.) A Warranty Evaluation Form must accompany all defective parts. Warranty is voided by product abuse, alterations, and use of equipment in applications for which it was not intended, use of non-manufacturer parts, or failure to follow documented service instructions. The foregoing warranty is exclusive of all other warranties whether written or oral, expressed or implied. No warranty of merchantability or fitness for a particular purpose shall apply. The agents, dealer and employees of Manufacturer are not authorized to make modification to this warranty, or additional warranties binding on Manufacturer. Therefore, additional statements, whether oral or written, do not constitute warranty and should not be relied upon.

The Manufacturer's sole responsibility for any breach of the foregoing provision of this contract, with respect to any product or part not conforming to the Warranty or the description herein contained, is at its option (a) to repair, replace or refund such product or parts upon the prepaid return thereof to location designated specifically by the Manufacturer. Product returns not shipped prepaid or on an economical transportation basis will be refused (b) as an alternative to the foregoing modes of settlement - the Manufacturer's dealer to repair defective units with reimbursement for expenses, except labor, and be reviewed with the Manufacturer prior to repair. A Warranty Evaluation Form must accompany all warranty claims.

Except as set forth hereinabove and without limitation of the above, there are no warranties or other affirmations which extends beyond the description of the products and the fact hereof, or as to operational efficiency, product reliability or maintainability or compatibility with products furnished by others. In no event whether as a result of breach of contract or warranty or alleged negligence, shall the Manufacturer be liable for special or consequential damages including but not limited to: Loss of profits or revenues, loss of use of the product or any associated product, cost of capital, cost of substitute products, facilities or services or claims of customers.

No claim will be allowed for products lost or damaged in transit. Such claims should be filed with the carrier within fifteen days.

Effective September 2001.



**Stone Construction Equipment, Inc.**  
32 East Main Street, P. O. Box 150  
Honeoye, NY 14471-0150

**Phone: 1-800-888-9926 • 1-716-229-5141**  
**Fax: 1-716-229-2363**  
[www.stone-equip.com](http://www.stone-equip.com) • e-mail: [sceny@mcimail.com](mailto:sceny@mcimail.com)

# Technical Data

## Machine Data - 1050PM, 1265PM, 1285PM & 1650PM

| MODEL                                      | STONE<br>1050PM   | STONE<br>1265PM                             | STONE<br>1285PM   | STONE<br>1650PM   |
|--|---|---|---|---|
| <b>Dimensions</b>                          |   |   |   |   |
| Operating Wt.<br>lbs. / kg                 | 875 / 396,9   | 1085 / 492,1                                | 1120 / 508  | 1267 / 574,7  |
| Batch Capacity<br>Bags                     | 2 ½ - 3 ½   | 3 - 4                                       | 3 - 4   | 4 ½ - 5 ½   |
| Batch Capacity<br>cu. ft. / m <sup>3</sup> | 10 / ,28  | 12 / ,34                                    | 12 / ,34  | 16 / ,45  |
| Total Volume<br>cu. ft. / m <sup>3</sup>   | 11.5 / ,33  | 14.8 / ,42                                  | 14.8 / ,42  | 19.5 / ,55  |
| Shipping Dimensions<br>L x W x H / cm      | 75 x 56 x 59<br>190,5 x 142,2 x 150   | 81 x 56 x 59<br>205,7 x 142,2 x 150         | 81 x 56 x 59<br>205,7 x 142,2 x 150                             | 81 x 56 x 59<br>233,7 x 142,2 x 150                             |
| Engine                                     | 10 hp B&S,<br>8.5 hp Robin,<br>11 hp Honda,<br>8 hp B&S I/C,<br>8 hp B&S I/P<br>3 hp Electric | 10 hp B&S,<br>11 hp Honda,<br>3 hp Electric | 11 hp Robin,<br>11 hp Honda,<br>18 hp B&S I/C,<br>5 hp Electric | 11 hp Robin,<br>11 hp Honda,<br>18 hp B&S I/C,<br>5 hp Electric |
| Drive & Clutch                             | V-belts to Gears<br>Front Post Hand Clutch  | V-belts to Gears<br>Front Post Hand Clutch  | Totally enclosed<br>gear drive & clutch<br>(no chain or belt)   | Totally enclosed<br>gear drive & clutch<br>(no chain or belt)   |

Mortar Mixer Features: Bag Splitter, Safety Guard, Patented Guard Lifter, Safety Chain

# Technical Data

## Torque Chart - Imperial

| SAE GRADE 5<br>Coarse Thread, Zinc-Plated |          |       |
|---|----------|-------|
| SIZE                                      | TORQUE   |       |
|   | ft. lbs. | Nm    |
| 1/4 - 20 (.250)                           | 6        | 8     |
| 5/16 - 18 (.3125)                         | 13       | 18    |
| 3/8 - 16 (.375)                           | 23       | 31    |
| 7/16 - 14 (.4375)                         | 37       | 50    |
| 1/2 - 13 (.500)                           | 57       | 77    |
| 9/16 - 12 (.5625)                         | 82       | 111   |
| 5/8 - 11 (.625)                           | 112      | 152   |
| 3/4 - 10 (.750)                           | 200      | 271   |
| 7/8 - 9 (.875)                            | 322      | 436.5 |
| 1 - 8 (1.000)                             | 483      | 655   |

| SAE GRADE 8<br>Coarse Thread, Zinc-Plated |          |     |
|---|----------|-----|
| SIZE                                      | TORQUE   |     |
|   | ft. lbs. | Nm  |
| 1/4 - 20 (.250)                           | 9        | 12  |
| 5/16 - 18 (.3125)                         | 18       | 24  |
| 3/8 - 16 (.375)                           | 33       | 45  |
| 7/16 - 14 (.4375)                         | 52       | 70  |
| 1/2 - 13 (.500)                           | 80       | 108 |
| 9/16 - 12 (.5625)                         | 115      | 156 |
| 5/8 - 11 (.625)                           | 159      | 215 |
| 3/4 - 10 (.750)                           | 282      | 382 |
| 7/8 - 9 (.875)                            | 454      | 615 |
| 1 - 8 (1.000)                             | 682      | 925 |

| SAE GRADE 5<br>Fine Thread, Zinc-Plated |          |     |
|---|----------|-----|
| SIZE                                    | TORQUE   |     |
|   | ft. lbs. | Nm  |
| 1/4 - 28 (.250)                         | 7        | 10  |
| 5/16 - 24 (.3125)                       | 14       | 19  |
| 3/8 - 24 (.375)                         | 26       | 35  |
| 7/16 - 20 (.4375)                       | 41       | 56  |
| 1/2 - 20 (.500)                         | 64       | 87  |
| 9/16 - 18 (.5625)                       | 91       | 123 |
| 5/8 - 18 (.625)                         | 128      | 173 |
| 3/4 - 16 (.750)                         | 223      | 302 |
| 7/8 - 14 (.875)                         | 355      | 481 |
| 1 - 12 (1.000)                          | 529      | 717 |
| 1 - 14 (1.000)                          | 541      | 733 |

| SAE GRADE 8<br>Fine Thread, Zinc-Plated |          |      |
|---|----------|------|
| SIZE                                    | TORQUE   |      |
|   | ft. lbs. | Nm   |
| 1/4 - 28 (.250)                         | 10       | 14   |
| 5/16 - 24 (.3125)                       | 20       | 27   |
| 3/8 - 24 (.375)                         | 37       | 50   |
| 7/16 - 20 (.4375)                       | 58       | 79   |
| 1/2 - 20 (.500)                         | 90       | 122  |
| 9/16 - 18 (.5625)                       | 129      | 175  |
| 5/8 - 18 (.625)                         | 180      | 244  |
| 3/4 - 16 (.750)                         | 315      | 427  |
| 7/8 - 9 (.875)                          | 501      | 679  |
| 1 - 12 (1.000)                          | 746      | 1011 |
| 1 - 14 (1.000)                          | 764      | 1036 |

t-chrt\_i.doc

# Technical Data

## Torque Chart - Metric

### Property Class 8.8

ZINC-PLATED

| SIZE |
|------|
| M6   |
| M8   |
| M10  |
| M12  |
| M14  |
| M16  |
| M20  |
| M24  |

#### Coarse Thread

| Nm  | ft. lbs. |
|-----|----------|
| 9.9 | 7        |
| 24  | 18       |
| 48  | 35       |
| 83  | 61       |
| 132 | 97       |
| 200 | 148      |
| 390 | 288      |
| 675 | 498      |

#### Fine Thread

| Nm  | ft. lbs. |
|-----|----------|
| 10  | 7        |
| 25  | 18       |
| 49  | 36       |
| 88  | 65       |
| 140 | 103      |
| 210 | 155      |
| 425 | 313      |
| 720 | 531      |

### Property Class 10.9

ZINC-PLATED

| SIZE |
|------|
| M6   |
| M8   |
| M10  |
| M12  |
| M14  |
| M16  |
| M20  |
| M24  |

#### Coarse Thread

| Nm  | ft. lbs. |
|-----|----------|
| 14  | 10       |
| 34  | 25       |
| 67  | 49       |
| 117 | 86       |
| 185 | 136      |
| 285 | 210      |
| 550 | 406      |
| 950 | 701      |

#### Fine Thread

| Nm   | ft. lbs. |
|------|----------|
| 14   | 10       |
| 35   | 26       |
| 68   | 50       |
| 125  | 92       |
| 192  | 142      |
| 295  | 218      |
| 600  | 443      |
| 1000 | 738      |

### Property Class 12.9

ZINC-PLATED

| SIZE |
|------|
| M6   |
| M8   |
| M10  |
| M12  |
| M14  |
| M16  |
| M20  |
| M24  |

#### Coarse Thread

| Nm   | ft. lbs. |
|------|----------|
| 16.5 | 12       |
| 40   | 30       |
| 81   | 60       |
| 140  | 103      |
| 220  | 162      |
| 340  | 251      |
| 660  | 487      |
| 1140 | 841      |

#### Fine Thread

| Nm   | ft. lbs. |
|------|----------|
| 16.5 | 12       |
| 42   | 31       |
| 82   | 60       |
| 150  | 111      |
| 235  | 173      |
| 350  | 258      |
| 720  | 531      |
| 1200 | 885      |

Conversion Factor: 1 ft. lb. = 1.3558 Nm



# Technical Data

# Hardware Identification

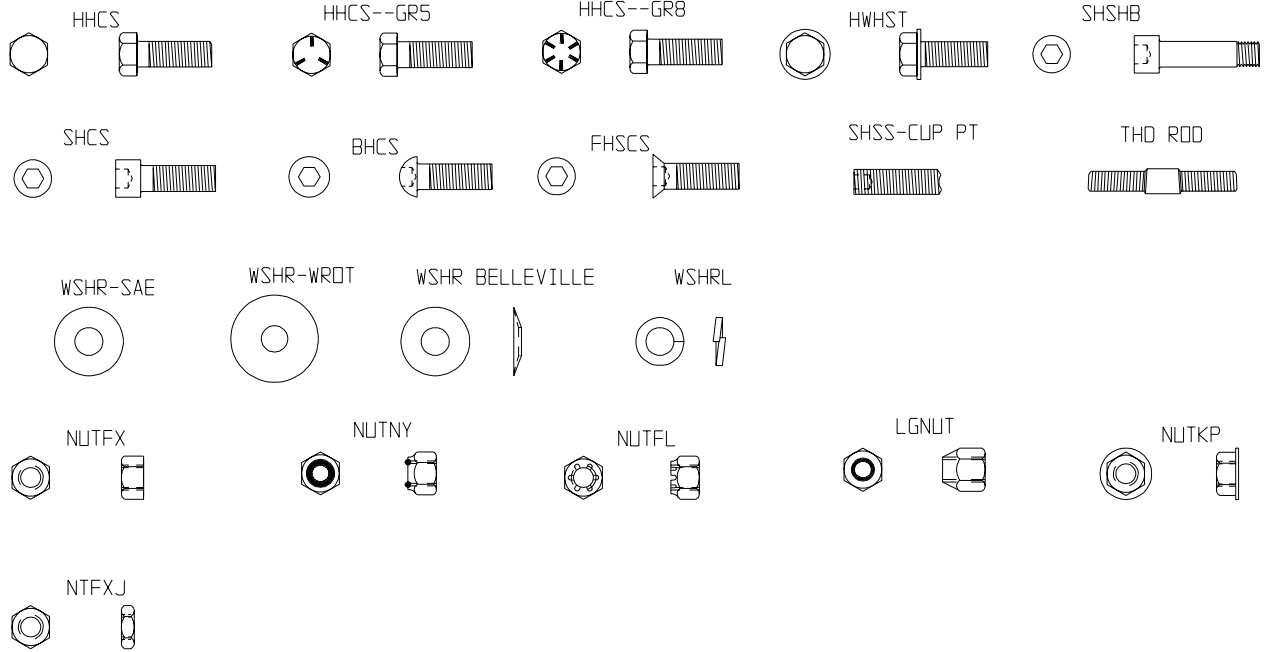

### **SAFETY**

These machines are designed to carry out the function of mixing material of the non-cohesive, bituminous and granular varieties.

If used correctly, they will provide an effective and safe means of mixing and meet the appropriate performance standards.

It is essential that the operator of the machine is adequately trained in its safe operation, be authorized to operate it, and have sufficient knowledge of the machine to ensure that it is in full working order, before being put to use.

# Health & Safety

## Safety Precautions



- Before using this equipment, study the entire Owner's Manual to become familiar with its operation. Do not allow untrained or unauthorized personnel, especially children, to operate this equipment. Use only factory authorized parts for service.



- When warning decals are destroyed or missing, contact the Manufacturer immediately at 1-800-888-9926 for replacement. For the safety of yourself and others, it is imperative that the following rules are observed. Failure to do so may result in serious injury or death.



- This notation appears before warnings in this manual. It means that the following steps must be carried out to avoid the possibility of personal injury or death. These warnings are intended to help the technician avoid potential hazards encountered in normal service procedures. We strongly recommend the reader take advantage of the information provided to prevent personal injury or injury to others.

### Follow Safety Instructions

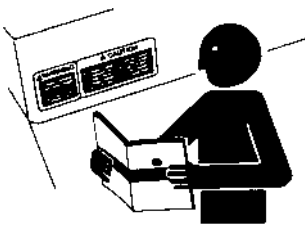

- Carefully read all safety messages and decals in this manual and on your machine safety signs. Keep decals in good condition. Replace missing or damaged decals. Be sure new equipment components and repair parts include the current safety signs. Replacement safety signs and decals are available through your dealer.
- Learn how to operate the machine and how to use controls properly. Do not let anyone operate without instruction.
- Keep your machine in proper working condition. Unauthorized modifications to the machine may impair the function and/or safety and affect machine life.
- If you do not understand any part of this manual and need assistance, contact your dealer.



**DANGER**  
**WARNING**  
**CAUTION**

### Understand Signal Words

- A signal word – **DANGER**, **WARNING**, or **CAUTION** – is used with the safety-alert symbol. **DANGER** identifies the most serious hazards.
- **DANGER or WARNING safety signs are located near specific hazards. General precautions are listed on CAUTION safety signs. CAUTION also calls attention to safety messages in this manual.**

# Health & Safety

## Safety Precautions



### Warning - Loose Hardware

- With power off, daily check for loose hardware. Immediately inform your supervisor to have it corrected--Do Not Run the Mixer.



### Warning-Handling Fuel

- Transport and handle fuel only when contained in approved safety containers.
- Do not smoke when refueling the mixer or during any other fuel handling operation.
- Do not refuel the mixer with the unit running or while hot.
- If fuel is spilled during refueling, wipe it off the engine immediately and discard the rag in a safe place.
- Do not operate the equipment if fuel or oil leaks exist – repair immediately.
- Never operate this equipment in an explosive atmosphere.



### Warning-Operating

- Never perform any work on the mixer while it is running.
- Before working on the mixer, stop the engine and disconnect the spark plug wire(s) to prevent accidental starting. If electric, unplug motor.
- Keep cowl closed during operation.
- Keep hands, clothing and jewelry away from all moving parts.
- Keep all guards in place, including drum guards.
- Never stick your hands or any solid object into the drum while it is in operation.



### Warning-Hot Surfaces

- Avoid contact with hot exhaust system and engines.
- Allow engine to cool before performing any repairs or service.



# Health & Safety

## Safety Precautions

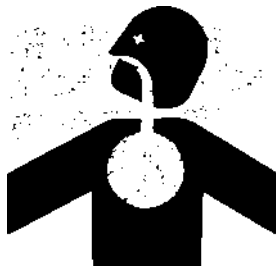

### Warning-Ventilation

- Never operate any gas powered mixer in a poorly ventilated or enclosed area.
- Avoid prolonged breathing of exhaust gases.
- Engine exhaust fumes can cause sickness or death.



### Warning-Extension Cords

- Always use the proper size grounded extension cord, conforming to the National Electric Code and Local Ordinances.
- Inspect all extension and extension and electrical cords for cuts, frayed wire and broken connectors before use. Do not use cords if not in good condition.
- Do not route extension cords through standing water.
- Do not operate the mixer in standing water.
- When cleaning the mixer, never spray water over the motor.



### Wear Protective Clothing

- Wear close fitting clothing and safety equipment appropriate to the job.
- Prolonged exposure to loud noise can cause impairment or loss of hearing.
- Wear a suitable hearing protective device such as earmuffs or earplugs to protect against objectionable or uncomfortable loud noises.
- Operating equipment safely requires the full attention of the operator. Do not wear radio or music headphones while operating machine.

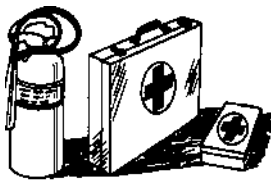

### Prepare for Emergencies

- Be prepared if a fire starts.
- Keep a first aid kit and fire extinguisher handy.
- Keep emergency numbers for doctors, ambulance service, hospital, and fire department near your telephone.



### Warning-Eye Protection

- Always wear splash goggles when operating mixer.

# Health & Safety

## Safety Precautions



### Warning-Towing

- Warning: Do not tow the mixer with the drum in the dump position. Mixer may become unstable and tip over when hitting a curb, pothole, or other obstruction.
- Warning: Always properly attach safety chains before mixer is towed. Maximum towing speed 55 m.p.h. (90 km/hr). Reduce speed according to highway conditions.



### Warning-Starting Fluid

- Starting fluid (ether) is highly flammable, do not use or an explosion or fire may result.



### Practice Safe Maintenance

- Understand service procedure before doing work. Keep area clean and dry.
- Never lubricate, service or adjust machine while it is moving. Keep hands, feet, and clothing from power-driven parts. Disengage all power and operate controls to relieve pressure. Lower equipment to the ground. Stop the engine. Remove the key. Allow machine to cool.
- Securely support any machine elements that must be raised for service work.
- Keep all parts in good condition and properly installed. Fix damage immediately. Replace worn or broken parts. Remove any buildup of grease, oil, or debris.
- Disconnect battery ground cable (-) before making adjustments on electrical systems or welding on machine.

### Dispose of Waste Properly

- Improperly disposing of waste can threaten the environment and ecology. Potentially harmful waste used with equipment includes such items as oil, fuel, coolant, brake fluid, filters, and batteries.
- Use leakproof containers when draining fluids. Do not use food or beverage containers that may mislead someone into drinking from them.
- Do not pour waste onto the ground, down a drain, or into any water source.
- Air conditioning refrigerants escaping into the air can damage the Earth's atmosphere. Government regulations may require a certified air conditioning service center to recover and recycle used air conditioning refrigerants.
- Inquire about the proper way to recycle or dispose of waste from your local environmental or recycling center.

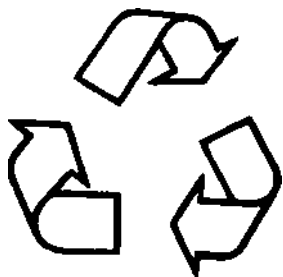

# Introduction

## Intro/Operating Principle/Delivery Checks/Before Starting/Determining the Right Machine

Congratulations on your purchase of a Stone Champion™ Mortar Mixer! You've made an excellent choice! Stone mixers have been specifically designed as the ideal machine for the professional contractor.

Upon receipt of your equipment, **CAREFULLY CHECK FOR ANY FREIGHT DAMAGE.** Any damage should be immediately reported to the carrier and a claim registered.

Stone Champion™ Mortar Mixers are manufactured to the strictest specifications and inspection procedures. If any material or manufacturing defects are found, return the tag on the machine with assembler's signature and your findings to the manufacturer. We want to know when a product is less than perfect. We also welcome any and all input about how the product may serve you better.

### OPERATING PRINCIPLE

The following instructions were compiled to provide you information on how to obtain long and trouble-free use of your unit. Periodic maintenance of this unit is essential. Read the manual in its entirety and follow the instructions carefully. Failure to do so may injure yourself or a bystander.

**DELIVERY CHECKS**--Immediately upon taking delivery of your new equipment and before putting it into service:

- Read the handbook completely--it could save a great deal of unnecessary expense.
- Read the engine manual supplied.
- Check the general condition of the equipment--has it been damaged during delivery?
- Check engine oil level.
- Check fuel levels.

Recommended lubricants are detailed in the Maintenance section.

**BEFORE STARTING**--These starting instructions are general guidelines only. Consult the engine manual included with this unit for specific instructions.

### DETERMINING THE RIGHT MACHINE

**1050PM**--Ideal for jobs requiring a 10 cu.ft. mixer.

**1265PM**--Ideal mid-range all purpose size with 12 cu.ft. capacity.

**1285PM**--Utilized for jobs requiring maximum productivity with an 12 cu.ft. size.

**1650PM**--Applicable for jobs requiring 16 cu.ft. capacity.

Mix only Mortar, Plaster, Terrazzo, Fireproofing and Grout. Do not operate machine if rocks, stones, ice or frozen materials are in mix and/or in drum of mixer.

The Stone Champion™ mixer line provides the most popular sizes and configurations available. Engine options available can accommodate any job. Engines available are 8hp B&S, 8hp B&S I/P, 9.2hp Wisconsin, 10hp B&S I/P, 11hp Honda, 18 hp B&S electric start and 5hp Electric.

# Introduction

## Standard Features/Preparation for Service

### STANDARD FEATURES

Your new mixer comes standard with some or all of the following features:

**Patented Automatic Guard Lifter**--Lifts the drum guard as drum is tilted to prevent mix from being poured through the guard causing build up. The guard and guard lifter system is designed for your safety and convenience, please **DO NOT** operate the mixer with the guard lifter disconnected or the guards removed.

**Quadruple Shaft Seal**--Provides a life long neoprene and urethane seal system that completely isolates the sealed ball bearings in the drum trunnions from the mix.

**Back Dump**--The back dumping system allows the drum to be tipped over backwards to facilitate cleaning of units mounted in front of plaster pumps, troughs, etc.

**Handwheel 1650 Only**--The handwheel dump system provides more leverage for easier dumping of these large capacity mixers.

**Power Blend Paddle System 1265PM and 1285PM**--Adds a new dimension to the mixing action. The sharper angle at which the blades enter the mix divides, separates and recombines in addition to the normal folding and extruding actions. The blades "cut" the mix rather than "plow it", resulting in a more lateral movement and less energy consumption. This cutting action minimizes the unproductive rolling action common to other mixers. The six paddles with longer blades insures a thorough mix in minimum time.

**Curved Plaster Blades Option for 1265PM and 1285PM**--The Power Blend Paddle System is recommended for mixing plaster and fireproofing materials. It can be used with or without rubber blades. It features curved blades to facilitate cleaning and curved ends on the long blades to minimize splashing and balling "of the mix".

### PREPARATION FOR SERVICE

#### READ ENGINE OWNERS MANUAL.

**Before Starting**--Mixers are shipped completely assembled and ready for operation except for installation of the safety chain and dump handle.

**Safety Chain Installation**--Remove the safety chain kit from the engine compartment. The kit includes (1) 12 ft. length of safety chain and (2) connecting links. Pull one end of the chain through the (2) key hole slots located in the front post of the mixer with a hook (see drawing below and decal on mixer front post). Attach the connecting links to each end of the chain. Follow the instructions in the **Towing** section of this manual and on the mixer front post to attach the safety chain to the towing vehicle.

### INSTALLING CHAIN TO MIXER

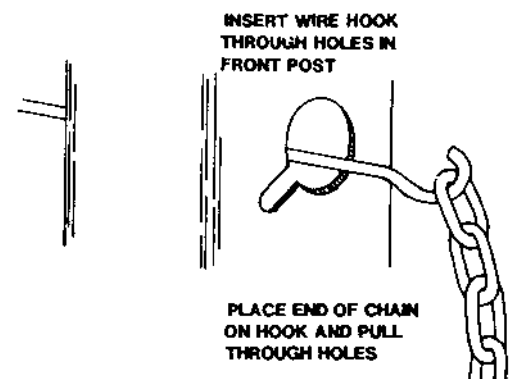



# Introduction

## Before Starting (cont'd)

**Dump Handle Installation 1050PM, 1265PM and 1285PM**--Remove the dump handle from the mixer drum where it is attached to the paddle shaft.

Consult the **FRAME AND DRUM ASSEMBLY** section of the Service/Parts Manual and use the (2) 3/8 bolts and nuts provided near the top, tow pole end of the drum to install the drum handle as shown in the exploded view. Do not torque bolt that holds the guard - see note in the **TORQUE CHART** section of this manual.

**Oil Levels and Lubrication**--Be sure to check the oil levels in the engine and engine reduction unit before starting this unit. The **ENGINE WARRANTY IS VOID** if it is run without oil. Consult the **ENGINE MANUAL** supplied with this unit for specific instructions and oil recommendations.

**Axle Blocks (Spring Axle Option Only)**--Before your mixer was shipped, wood blocks were placed in the axle springs to avoid bouncing during transport. Before operation, loosen spring bolts, remove blocks and retighten spring bolts until locknut is fully engaged.

**Rubber Blades**--Are factory pre-set. Due to local preferences, some readjustment may be desired.

# Introduction

## Hardware/Fuel/Location and Use of Controls



**BEFORE WORKING ON MACHINE, MAKE SURE ENGINE SPARK PLUG WIRE IS DISCONNECTED, OR, IF ELECTRIC, THAT THE ELECTRIC CORD IS DISCONNECTED, TO PREVENT ANY ACCIDENTAL STARTING.**

**Hardware**--Check all hardware on mixer and engine/motor before starting. Consult the **TORQUE CHART** section of this manual and tighten any loose hardware accordingly.

**Fuel**--If your mixer is equipped with a gasoline engine, fill the gas tank with clean gasoline from a safety can. Consult the **ENGINE MANUAL** supplied with this unit for the proper type of gasoline required.

**DO NOT** mix oil with gasoline.

Before operating this unit, it is important to familiarize yourself, and any other personnel who will be using it, with the location and proper use of the controls to insure safe and efficient operation.

A. Always make sure that the drum latch is in the lock position (down) before starting machine. With engine running, turn clutch lever to the right to turn paddles or to the left to stop.

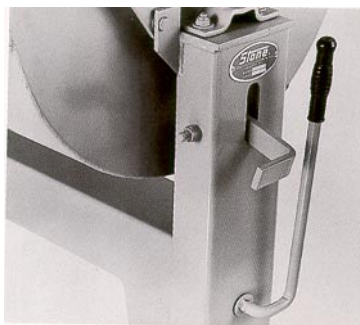

B. To dump mix from drum, stop paddles, move drum latch up and pull dump handle down. Always use caution when dumping mix.

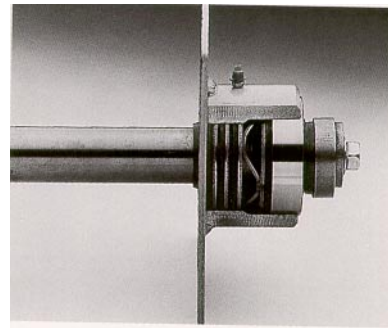
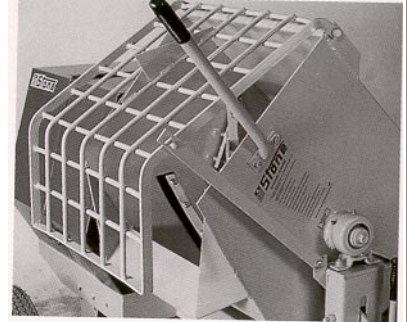

C. Always grease drum seals as recommended in the maintenance chart. The grease purges dirt--prolonging bearing life.

D. Always keep drum and paddles clean. Never run machine with hardened mix or foreign objects in drum--doing so damages paddles and/or engine.

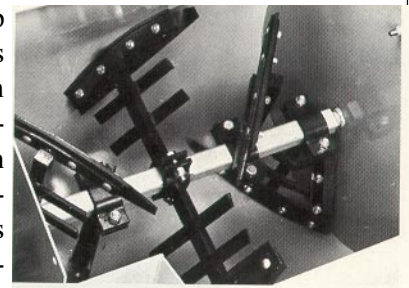

# Operations

## To Start/To Stop



FOLLOW THE GUIDELINES FOUND IN THE *SAFETY PRECAUTION* SECTION OF THIS MANUAL WHENEVER HANDLING GASOLINE.

### TO START

#### **Disengage Drive Train 1050PM and 1265PM--**

Move clutch lever located at front of mixer to the up position (lever parallel to front post).

#### **Disengage Drive Train 1285PM and 1650PM--**

Move clutch lever located at left side of mixer to the rear position (until clutch snaps out of engagement).

**Check Drum Dump Latch--**Make sure that the drum latch is engaged with the drum in the upright or mixing position.

### START THE ENGINE/MOTOR GASOLINE ENGINE

**Cold Start--**Open the fuel valve under the gas tank all the way. Open the throttle approximately half way and apply the choke. Pull the starter rope sharply about (3) times. When the engine starts, open the choke and adjust the throttle as necessary to keep it running. Allow the engine to warm up for a few minutes before placing it under load. If the engine doesn't start after (3) pulls, open choke slightly to prevent flooding. Always operate the engine at full throttle when under load.

**Hot Start--**Open the valve under the gas tank all the way if it has been shut off. Open the throttle approximately half way. Do not apply the choke. Pull

the starter rope sharply until the engine starts. When the engine starts, adjust the throttle. Always operate the engine at full throttle when under load.

**NOTE:** These starting instructions are general guidelines only. Since many engine Options are available on the manufacturer's PM mixers, consult the ENGINE MANUAL included with this unit for specific instructions.



**ELECTRIC MOTORS--USE THE PROPER SIZE (3) WIRE (GROUNDED) EXTENSION CORD, CONFORMING TO THE NATIONAL ELECTRIC CODE AND LOCAL ORDINANCES. Do Not USE (2) WIRE EXTENSION CORD. CHECK ANY EXTENSION CORD WHICH YOU PLAN ON USING CAREFULLY FOR BROKEN CONNECTORS, BARE WIRES AND DAMAGED INSULATION. Do Not USE ANY CORD FOUND TO BE IN POOR CONDITION. MAKE SURE THE EXTENSION CORD IS NOT ROUTED THROUGH STANDING WATER AND THAT ALL THE CONNECTIONS ARE TIGHT. USE THE SHORTEST EXTENSION CORD POSSIBLE. TURN MOTOR ON.**

**Electric Motor Switch--**Located on the motor. It is used to start and stop the electric mixer.

### TO STOP THE ENGINE / MOTOR

**Gasoline Engines--**To improve the engine service life, move the clutch lever to the up position to disengage the drive train and allow the engine to idle without load for (2) to (5) minutes before shutting it down. When the idling period is up, use the grounding clip, engine stop switch or oil minder switch to stop the engine. Consult the ENGINE MANUAL included with this unit for specific instructions.

# Operations

## Operating

**CAUTION – IF THE MIXER IS TO BE LEFT UNATTENDED FOR ANY LENGTH OF TIME--CLOSE THE FUEL VALVE UNDER THE GAS TANK.**

**Electric Motors**--Disengage the drive train by moving the clutch lever to the up position. Turn the motor off using the switch.

**CAUTION – TURN THE MOTOR OFF. IF THE MIXER IS TO BE LEFT UNATTENDED FOR ANY LENGTH OF TIME--DISCONNECT THE POWER CORD.**

### OPERATING

Before drum can be tilted to dump mix, the drum lock bolt needs to be removed from the back dump stop mechanism. Do Not discard this bolt--it is required to lock the drum in an upright position for safe towing. Refer to Frame and Drum Assembly drawing for location of the above parts.

Start the engine / motor as instructed above and allow gasoline engines to reach operating temperatures. Close the engine cowl. **NEVER** operate the mixer with cowl open. **NEVER** operate the mixer with the drum guard open or removed. Move the clutch lever clockwise to the down position to engage the drive train and set mixer paddles in motion. For 1285PM and 1650PM, move clutch lever forward to engage the drive train.

The mixer is now ready for the addition of the mortar mix. For best results proceed as follows:

1. Pour half the required amount of water into drum.
2. Add half the required amount of sand.
3. Add the total required amount of mortar mix (cement, lime, etc.).
4. Add the balance of sand and water.

After mixing for the proper length of time (homogeneous mix obtained), discharge the mix from the drum by using the dump handle to dump the drum and control the discharge.

After discharge, if another batch of mortar is to be mixed, return the drum to the mixing position and make sure the drum latch is engaged. Immediately pour in half of the required water for the next batch with paddles turning. This will clean the paddles and drum between batches and help prevent lumps of dried mortar from forming and contaminating the next batch.

If no more mortar is to be mixed in the next hour or so, the mixer drum and paddles should be thoroughly cleaned. If no more mortar is to be mixed that day, the entire mixer should be thoroughly cleaned inside and outside to insure maximum life and performance.

# Maintenance

## Before Towing

**Before towing**--check the state and local laws that apply to your intended route and check the following:

1. Hitch attached to the towing vehicle securely.
2. Tow pole fully extended and bolted to mixer securely.
3. Safety chain hooked up properly (see illustration below or decal on mixer front post).
4. Drum lock bolt and nut inserted through back dump mechanism and tightened.
5. Lug nuts, wheel nuts and axle mount nuts tight.
6. Main axle springs and small snubber springs and bolts not broken or cracked.
7. Tires in good shape and at proper inflation: B78 x 13 tires need to be inflated to 35 P.S.I. to insure maximum safety and load capacity.

**Do NOT EXCEED TOWING SPEED OF 55 MPH/90 KMH. FOR POOR ROAD CONDITIONS OR INCLEMENT WEATHER--REDUCE SPEED ACCORDINGLY.**

Refer to FRAME AND DRUM ASSEMBLY, STANDARD AXLE ASSEMBLY and SPRING AXLE ASSEMBLY sections of the Service/Parts Manual for parts identification and location.

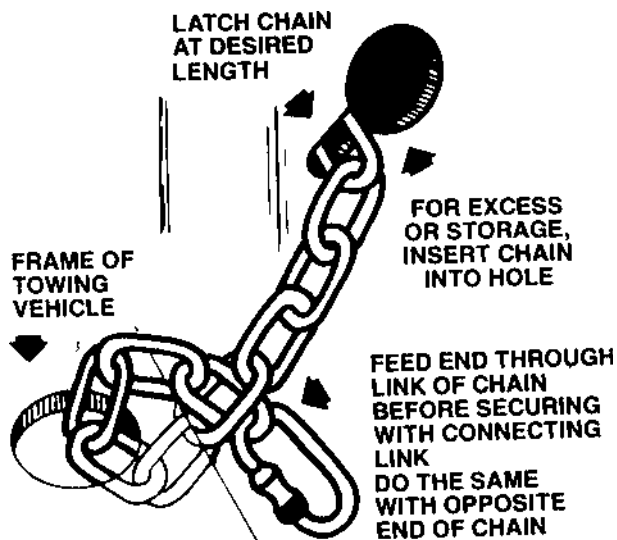

# Maintenance

## Maintenance and Lubrication



NEVER POUR OR SPRAY WATER OVER THE ENGINE OR MOTOR.



NEVER PUT HANDS OR ANY OBJECT INTO DRUM WHILE ENGINE OR MOTOR IS RUNNING.



ALWAYS DISCONNECT THE SPARK PLUG WIRE OR ELECTRIC CORD WHEN CLEANING INSIDE DRUM.



ALWAYS MAKE SURE GUARD LIFTER IS RECONNECTED TO GUARD BEFORE USING MIXER--DO NOT OPERATE MIXER WITH DRUM GUARD OPEN OR REMOVED.

### MAINTENANCE AND LUBRICATION

To get long and trouble-free service from this mixer, it is essential that you perform periodic maintenance on the engine and machine mechanisms. Follow the guide lines listed below:

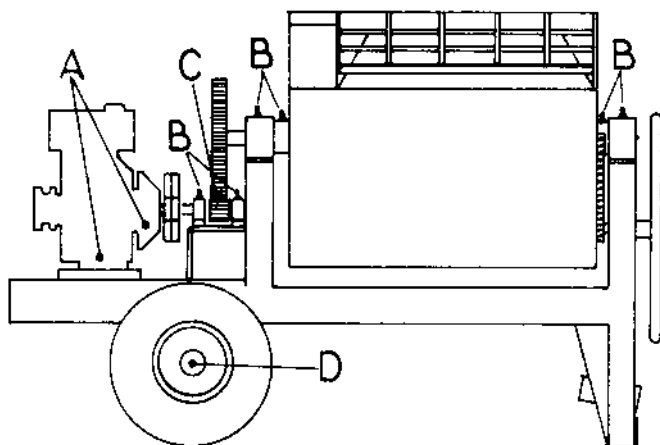

(Engine housing not shown for clarity)

- A. **ENGINE** - Daily check the oil levels in the engine and engine reduction unit daily. The engine warranty is **VOID** if run without oil. Since there are many options available on this mixer, consult the ENGINE MANUAL for specific recommendation as to oil level, oil type required and frequency of oil changes required. For maximum service life from the engine, follow those recommendations.
- B. **WEEKLY** - Grease drum bearings (2) places and trunnions (2) places. On the 1265PM models only, grease countershaft pillow block bearings (2) places on gas powered models and (4) places on the electric models.
- C. **BULL GEAR** - Lightly grease the bull gear and pinion after each 250 hours of operation. Avoid over-greasing as this will attract dirt and accelerate wear.
- D. **WHEEL HUBS** - Repack annually (4) tapered roller bearings in wheel hubs and replace wheel seals. Install washer and nut. Torque to 20 ft. lbs., back off one turn, torque to 7 ft. lbs., back off to first slot in nut and insert cotter key.
- E. If the mixer has been towed through deep mud or water, disassemble the wheel hubs and repack per D above with a good grade of high speed wheel bearing grease. **WHEEL BEARING LUBRICATION**--Fill wheel hub with grease to inside diameter of outer races and also fill hub grease cap. Never use grease heavier than 265 A.S.T.M. penetration (No. 2 grade). Grease bearing cone by machine or by hand method. Force grease between rollers, cone and cage. (If Ball Bearing Hub: force grease between balls.) It is not recommended that a pressure grease fitting be installed on the hub.

# Maintenance

## Maintenance Chart

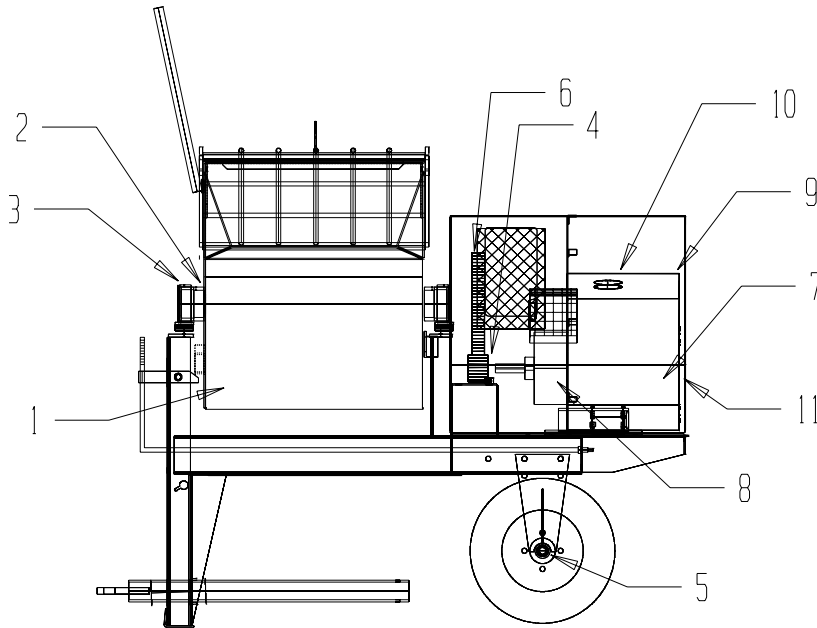

| MIXER MAINTENANCE<br>REFER TO MIXER OWNER'S MANUAL PROVIDED PRIOR<br>TO OPERATING OR SERVICING EQUIPMENT   | EVERY 5 HOURS<br>OR DAILY | 25 HOURS OR<br>EVERY WEEK | 50 HOURS OR<br>EVERY MONTH | 100 HOURS OR<br>EVERY YEAR |
|--|---------------------------|---------------------------|----------------------------|----------------------------|
| 1. MIXER: CLEAN MIXER INSIDE & OUT/REMOVE ALL BUILD UP   | CLEAN                     |                           |                            |                            |
| 2. DRUM SEALS: GREASE FITTINGS W/ LITHIUM BASE GREASE  |                           | GREASE                    |                            |                            |
| 3. TRUNNIONS: GREASE FITTINGS W/ LITHIUM BASE GREASE   |                           | GREASE                    |                            |                            |
| 4. PILLOW BLOCK BEARINGS: W/ LITHIUM BASE GREASE   |                           | GREASE                    |                            |                            |
| 5. WHEEL HUBS: REPACK EVERY YEAR W/ WHEEL BRG GREASE   |                           |                           |                            | EVERY YEAR                 |
| 6. BULL GEAR: LIGHTLY GREASE EVERY 250 HRS   |                           |                           |                            |                            |
| ENGINE MAINTENANCE<br>REFER TO ENGINE OWNER'S MANUAL PROVIDED PRIOR<br>TO OPERATING OR SERVICING EQUIPMENT |                           |                           |                            |                            |
| 7. OIL LEVEL: 40F-110F SAE 30W SE,SF,SG  | CHECK                     |                           | CHANGE *                   |                            |
| BELOW 40F SAE 10W-30 SE,SF,SG  | CHECK                     |                           | CHANGE *                   |                            |
| 8. REDUCTION OIL: SAE 30W SE,SF,SG   |                           |                           |                            | CHANGE                     |
| 9. AIR FILTER: PRE-CLEANER WASH IN SOAP & WATER/APPLY OIL  |                           | CLEAN **                  |                            | REPLACE                    |
| ELEMENT CLEAN BY TAPPING   |                           | CLEAN **                  |                            | REPLACE                    |
| 10. SPARK PLUG: CLEAN OR REPLACE   |                           |                           | CLEAN                      | REPLACE                    |
| 11. COOLING SYS & AIR SCREEN   |                           |                           |                            | CLEAN                      |

\* CHANGE OIL AFTER FIRST 5 HOURS, THEN EVERY 50 HOURS  
CHANGE OIL EVERY 25 HOURS UNDER HEAVY LOADS OR HIGH TEMPERATURES  
\*\* CLEAN/CHANGE AIR FILTER MORE OFTEN UNDER DUSTY CONDITIONS

SAFETY 1ST DISCONNECT SPARK PLUG OR ELECTRIC CORD BEFORE SERVICING  
DANGER DO NOT REFUEL WHEN ENGINE IS HOT OR SMOKE WHEN REFUELING  
AVOID PROLONGED BREATHING OF EXHAUST GASES PM004-A

# Maintenance

## Lubrication/Cleaning

### CLEANING

For consistent performance, long life and continued high quality mixing of plaster or mortar, thoroughly clean the mixer inside and out at the end of each day's operation. To prevent lumps of dried plaster from forming and contaminating future batches of plaster or mortar, do not allow built up materials to form on drum guards, around paddles or anywhere inside the drum.

Before cleaning, shut off the engine or motor and disconnect the spark plug wire or electric cord to prevent accidental starting. Spray the mixer with water before the mix dries to remove any accumulations. Dried mix should be scraped out as necessary. **DO NOT** beat on the drum with a shovel, hammer or other device to break up accumulations of dried mix, as this will dent and damage the drum.

**The Back Dump Feature**--this facilitates the cleaning of units mounted permanently, or semi-permanently in front of plaster pumps, troughs, etc. Dirty water and contaminants can be disposed of without running them through plaster pumps and other equipment. To back dump mixer, refer to Frame and Drum Assembly drawing and parts list for parts identification and proceed as follows:

1. Disconnect guard lifter (Item 26). Use dump handle (Item 1) and tilt drum far enough so that the dump stop will clear the frame.
2. Reverse procedure when completed.

**Gearcase Models 1285PM and 1650PM**--Refer to Gearcase Assembly Drawing and Parts List for parts identification located in the Parts/Service Manual.

Daily--check oil level in the gearcase. Oil level should be halfway across the oil sight glass plug in the clutch access cover located on the right side of gearcase.

Yearly--drain the gearcase and refill with fresh oil as follows:

1. On the gasoline powered models, disconnect spark plug wire(s). On electric models, disconnect electric cord at mixer.
2. Drain the old oil from the gearcase by removing the two magnetic drain plugs from the clutch access cover and the bottom of the gearcase. Note: both of these plugs have hexagonal heads--do not remove the square head plug at the bottom of the case.
3. After draining the oil from the gearcase, clean off the two magnetic drain plugs, reinstall and tighten securely.
4. Remove the oil fill plug from the upper right side of the gearcase and refill the gearcase with 2-1/4 quarts of SAE 90 motor oil. Replace the oil fill plug and tighten securely.
5. Reconnect spark plug wire(s) or electric cords, start engine/motor and run the mixer for a couple of minutes. Shut off the engine/motor, check for leaks and allow oil level to settle. Double check the oil level; it should be halfway across the oil sight glass plug in the clutch access cover.



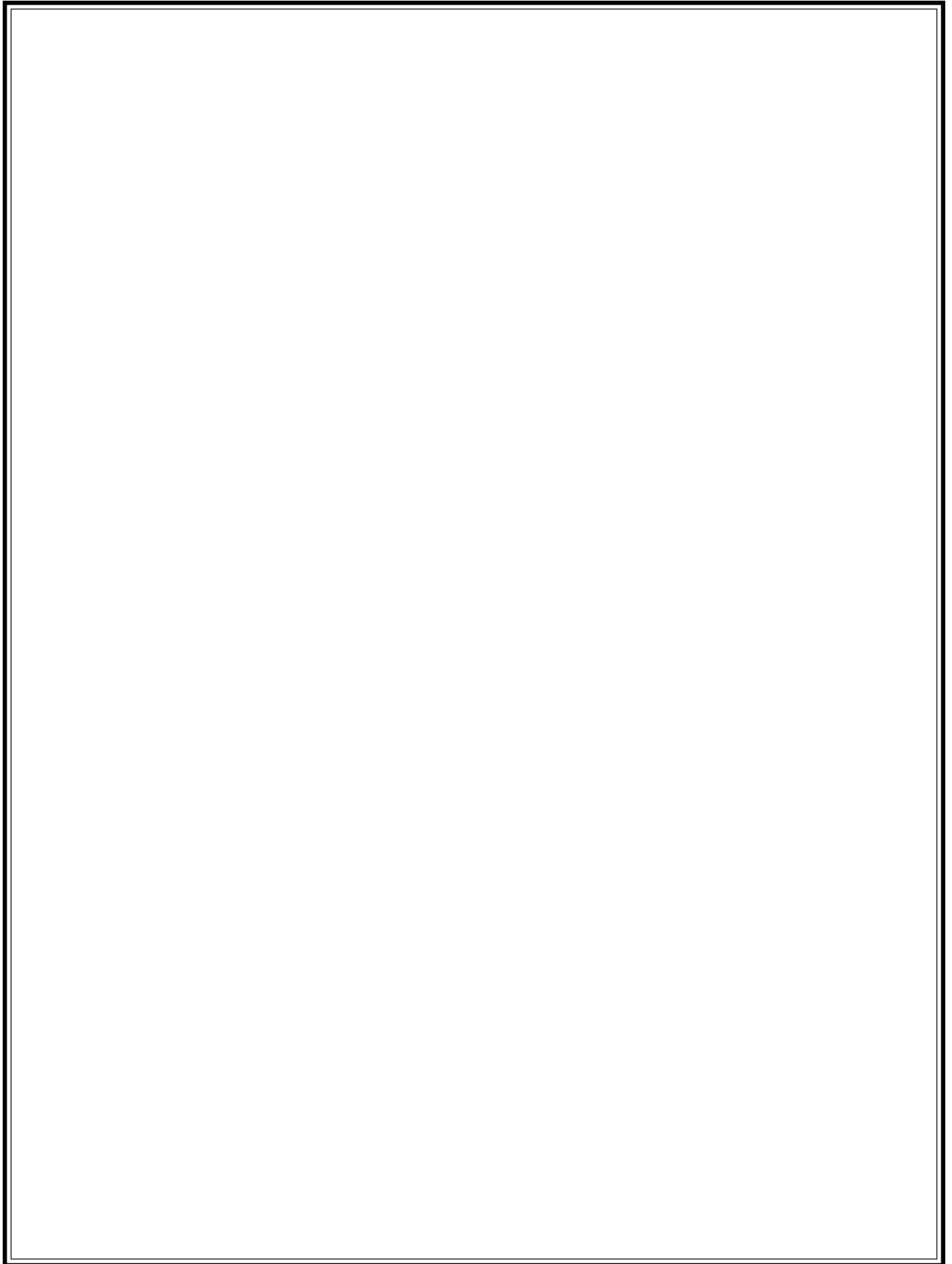

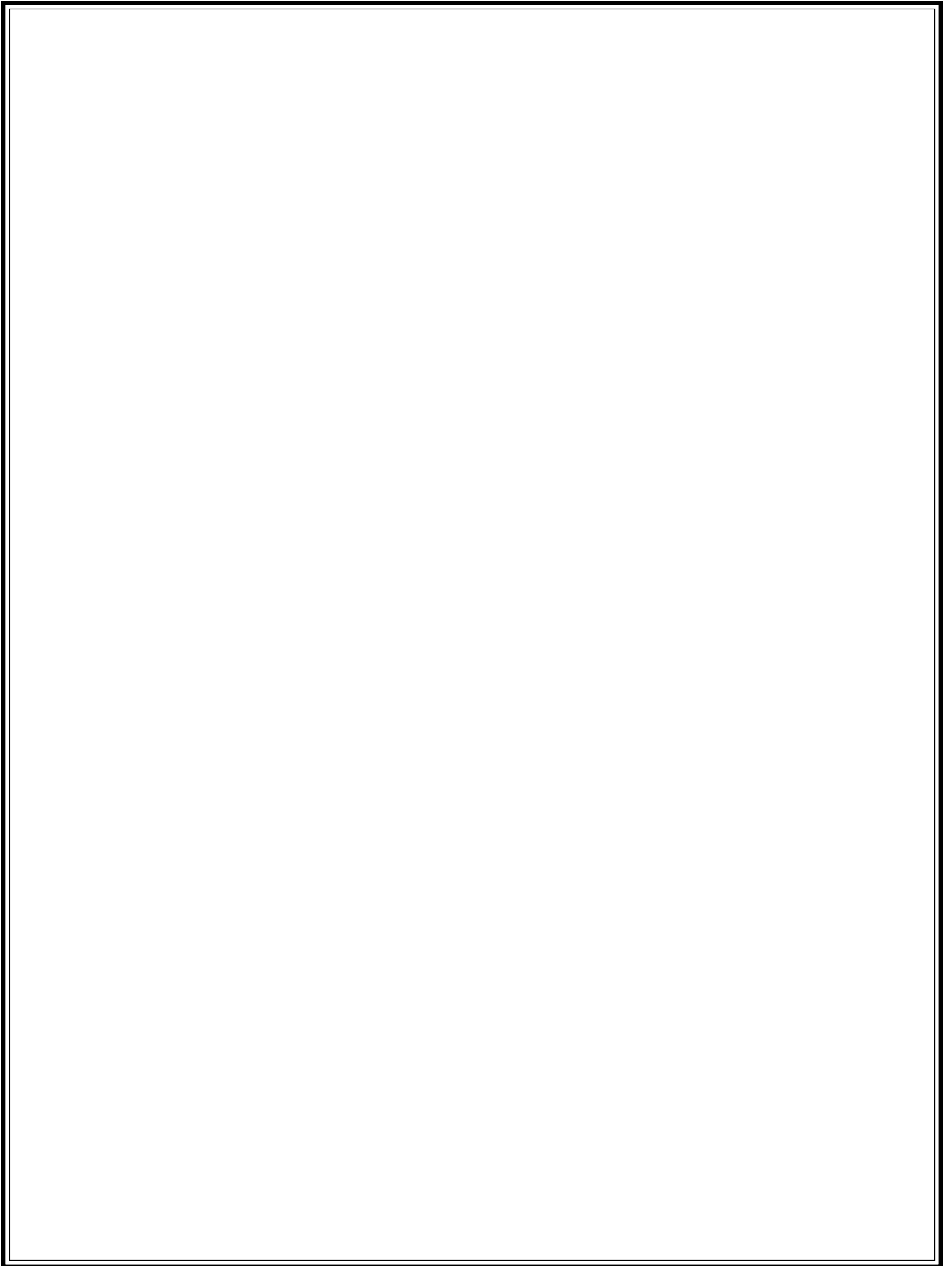

**CALIFORNIA PROPOSITION 65 WARNING: Engine exhaust from this product contains chemicals known to the State of California to cause cancer, birth defects, or other reproductive harm.**



Stone Construction Equipment, Inc.  
P.O. Box 150, Honeoye, New York 14471  
Phone: (800) 888-9926  
Fax: 716-229-2363  
e-mail: [sceny@mcimail.com](mailto:sceny@mcimail.com)  
www: [stone-equip.com](http://stone-equip.com)

A 100% employee-owned American manufacturer

© 1987 Stone Construction Equipment, Inc.  
Printed in U.S.A.