

OPERATION AND PARTS MANUAL



MC-44S CONCRETE MIXER

Revision #8 (09/15/11)

The logo for Discount Equipment features the word 'Discount' in a bold, blue, italicized font above the word 'Equipment' in a bold, blue, sans-serif font. The text is flanked by two orange arrows pointing outwards.

**Discount
Equipment**

www.discount-equipment.com

THIS MANUAL MUST ACCOMPANY THE EQUIPMENT AT ALL TIMES.

Discount Equipment

Discount-Equipment.com is your online resource for commercial and industrial quality parts and equipment sales.

Locations:

Florida (West Palm Beach): [561-964-4949](tel:561-964-4949)

Outside Florida TOLL FREE: [877-690-3101](tel:877-690-3101)

Need parts? Check out our website at www.discount-equipment.com

Can't find what you need?

Click on this link: <http://www.discount-equipment.com/category/5443-parts/> and fill out the request form.

Please have the machine model and serial number available in order to help us get you the correct parts. One of our experienced staff members will get back to you with a quote for the right part that your machine needs.

We sell worldwide for the brands: Genie, Terex, JLG, MultiQuip, Mayco, Toro/Stone, Diamond Products, Magnum, Airman, Mustang, Power Blanket, Nifty Lift, Atlas Copco, Chicago Pneumatic, Allmand Brothers, Essick, Miller Spreader, Skyjack, Lull, Skytrak, Tsurumi, Husquvarna/Target, Whiteman-Concrete/Mortar, Stow-Concrete/Mortar, Baldor, Wacker, Sakai, Snorkel, Upright, Mi-T-M, Sullair, Neal, Basic, Dynapac, MBW, Weber, Bartell, Bennar Newman, Haulotte, Ditch Runner, Blaw-Knox, Himoina, Best, Buddy, Crown, Edco, Wyco, Bomag, Laymor, Terremite, Barreto, EZ Trench, Takeuchi, Basic, Bil-Jax, Curtis, Gehl, Heli, Honda, ICS/PowerGrit, Puckett, Waldon, ASV, IHI, Partner, Imer, Clipper, MMD, Koshin, Rice, Gorman Rupp, CH&E, Cat Pumps, Comet, General Pump, Giant, AMida, Coleman, NAC, Gradall, Square Shooter, Kent, Stanley, Tamco, Toku, Hatz, Kohler, Robin, Wisconsin, Northrock, Oztec, Toker TK, Rol-Air, Small Line, Wanco, Yanmar

New Equipment - Used Equipment - Rental Equipment - Parts and Accessories

Discount Equipment

www.discount-equipment.com

561-964-4949

Sales: info@Discount-Equipment.com

Parts: wbparts@Discount-Equipment.com



CALIFORNIA — Proposition 65 Warning

Engine exhaust and some of its constituents, and some dust created by power sanding, sawing, grinding, drilling and other construction activities contains chemicals known to the State of California to cause cancer, birth defects and other reproductive harm. Some examples of these chemicals are:

- Lead from lead-based paints.
- Crystalline silica from bricks.
- Cement and other masonry products.
- Arsenic and chromium from chemically treated lumber.

Your risk from these exposures varies, depending on how often you do this type of work. To reduce your exposure to these chemicals: **ALWAYS** work in a well ventilated area, and work with approved safety equipment, such as dust masks that are specially designed to filter out microscopic particles.

MC-44S CONCRETE MIXER — TABLE OF CONTENTS

MULTIQUIP MC-44S Concrete Mixer

Proposition 65 Warning	2
Table Of Contents	4
Parts Ordering Procedures	5
Specifications	6
Dimensions (Mixer)	7
Safety Message Alert Symbols	8
Rules For Safe Operation	9-10
Operation and Safety Decals	11
General Information	12
Mixer Basic Components	13
Basic Engine Components	14
Handwheel Assembly	15
Towing Guidelines	16
Safety Chain Connection	17
Electric Motor	18-19
Pre-Inspection (Gasoline Engine)	20
Initial Start-up (Gasoline Engine)	21
Initial Start-up (Electric Motor)	22
Operation	23
Maintenance (Engine)	24-25
Maintenance (Mixer)	26-28
Troubleshooting (Engine)	30
Troubleshooting (Engine/Mixer)	31
Explanation Of Code In Remarks Column	32
Suggested Spare Parts	33

Componet Drawings

Nameplate and Decals	34-35
Mixer Assembly (Steel Drum)	36-37
Main Frame Assembly	38-39
Axle Assembly	40-41
Cabinet Assembly	42-43
Gas Engine Mounting Plate Asassembly	44-45
Electric Motor Mounting Plate Asassembly	46-47

HONDA GX120K1QX2 Engine

Air Cleaner Assembly	48-49
Camshaft Assembly	50-51
Carburetor Assembly	52-53
Control Assembly	54-55
Crankcase Cover Assembly	56-57
Crankshaft Assembly	58-59
Cylinder Barrel Assembly	60-61
Cylinder Head Assembly	62-63
Fan Cover Assembly	64-65
Flywheel Assembly	66-67
Fuel Tank Assembly	68-69
Ignition Coil Assembly	70-71
Muffler Assembly	72-73
Piston Assembly	74-75
Recoil Starter Assembly	76-77
Gasket Kit Assembly	78-79
Labels Assembly	80-81

Terms and Condition Of Sale — Parts	82
---	----

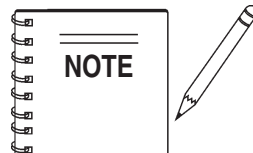

**Specification and part number
are subject to change without
notice.**

MC-44S CONCRETE MIXER — SPECIFICATIONS

Table 1. Specifications (Engine/Electric Motor)

	Model	HONDA GX120K1QX2	Baldor 34F324-5596
Engine/Electric Motor	Type	Air-cooled 4 stroke, Single Cylinder, OHV, Horizontal Shaft Gasoline Engine	1/2 HP, Single-phase 115 VAC, Electric Motor
	Bore X Stroke	2.7 in. X 1.7 in. (60 mm x 42 mm)	N/A
	Displacement	7.3 cu. in. (119 cc)	N/A
	Max Output	3.9 H.P./3,600 rpm	1/2 HP/1725 R.P.M.
	Fuel Tank Capacity	0.63 U.S. Gallons (0.60 Liters)	N/A
	Fuel	Unleaded Automobile Gasoline	N/A
	Lube Oil Capacity	0.63 qt. (0.6 liter)	N/A
	Speed Control Method	Centrifugal Fly-weight Type	N/A
	Starting Method	Recoil Start	Electric
	Input Voltage	N/A	115 VAC Single Phase
	Dimension (L x W x H)	11.7 x 13.4 X 12.5 in. (297 X 341 X 318 mm)	13.87 x 7.56 X 8.62 in. (352 X 192 X 219 mm)
Dry Net Weight	28.7 lbs (13.0 Kg.)	Approx. 12 lbs (5.4 kg.)	

Table 2. MC-44S Mixer Specifications

Height	60 in. (1,525 mm)
Width	51 in. (1,296 mm)
Length	66 in. (1,677 mm)
Maximum Drum Capacity	6.35 cu. ft. (180 liters)
Maximum Mixing Capacity	4 cu. ft. (113 liters)
Bag Capacity	(1/3 to 1/2 bag)
Weight - With Engine/Electric Motor	495 lbs. (224 Kg.)

MC-44S CONCRETE MIXER — DIMENSIONS (MIXER)

See Table 2 for mixer dimensions

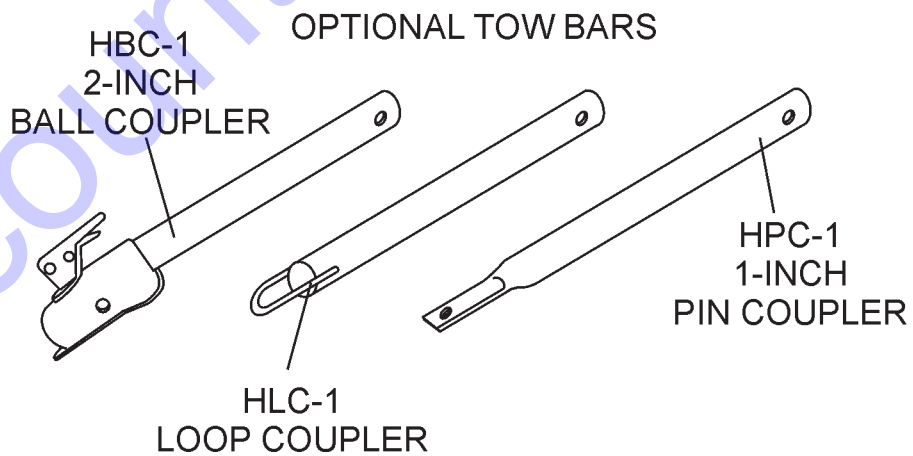
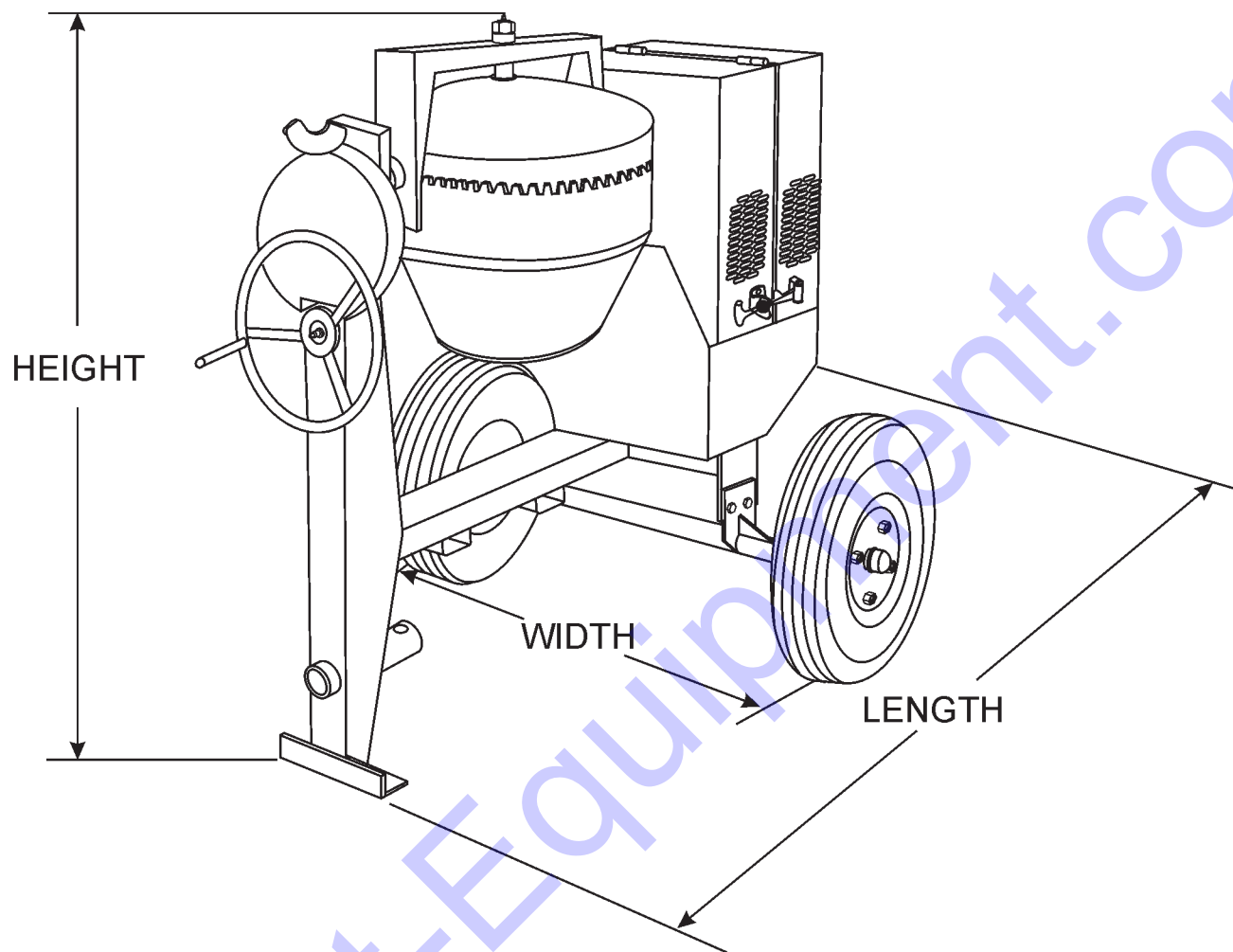
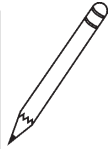
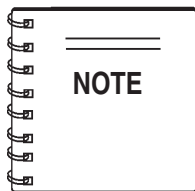

Figure 1. Mixer Dimensions

MC-44S CONCRETE MIXER — SAFETY MESSAGE ALERT SYMBOLS

FOR YOUR SAFETY AND THE SAFETY OF OTHERS!

Safety precautions should be followed at all times when operating this equipment. Failure to read and understand the Safety Messages and Operating Instructions could result in injury to yourself and others.



This Owner's Manual has been developed to provide complete instructions for the safe and efficient operation of the Multiquip *Model MC-44S (Steel) Concrete Mixer*.

Before using these mixers, ensure that the operating individual has read and understands all instructions in this manual.

SAFETY MESSAGE ALERT SYMBOLS

The three (3) Safety Messages shown below will inform you about potential hazards that could injure you or others. The Safety Messages specifically address the level of exposure to the operator, and are preceded by one of three words: **DANGER**, **WARNING**, or **CAUTION**.



DANGER: You **WILL** be **KILLED** or **SERIOUSLY** injured if you do not follow directions.



WARNING: You **CAN** be **KILLED** or **SERIOUSLY** injured if you do not follow directions.



CAUTION: You **CAN** be injured if you do not follow directions.

Potential hazards associated with the **Multiquip MC-44S** concrete mixer operation will be referenced with Hazard Symbols which appear throughout this manual, and will be referenced in conjunction with Safety Message Alert Symbols.

HAZARD SYMBOLS



Rotating Parts



NEVER operate equipment with covers, or guards removed. Keep fingers, hands, hair and clothing away from all moving parts to prevent injury.



Accidental Starting



OFF **ALWAYS** place the circuit breaker or power ON/OFF switch in the **OFF** position when the pump is not in use.



Sight and Hearing hazard

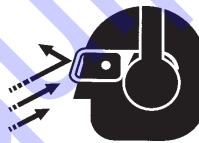

ALWAYS wear approved eye and hearing protection.



Respiratory Hazard



ALWAYS wear approved respiratory protection.



Equipment Damage Messages

Other important messages are provided throughout this manual to help prevent damage to your mixer, other property, or the surrounding environment.

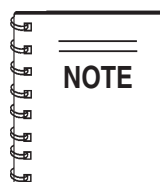

This mixer, other property, or the surrounding environment could be damaged if you do not follow instructions.

MC-44S CONCRETE MIXER — RULES FOR SAFE OPERATION

DANGER:



Failure to follow instructions in this manual may lead to serious injury or even death! This equipment is to be operated by trained and qualified personnel only! This equipment is for industrial use only.

The following safety guidelines should always be used when operating the **Multiquip MC-44S** Concrete Mixer:

GENERAL SAFETY

- **DO NOT** operate or service this equipment before reading this entire manual.



- This equipment should not be operated by persons under 18 years of age.

- **NEVER** operate this equipment without proper protective clothing, shatterproof glasses, steel-toed boots and other protective devices required by the job.



- **NEVER** operate this equipment when not feeling well due to fatigue, illness or taking medicine.



- **NEVER** operate this equipment under the influence of drugs or alcohol.



- Whenever necessary, replace nameplate, operation and safety decals when they become difficult read.

- **ALWAYS** check the machine for loosened threads or bolts before starting.

- **ALWAYS** wear proper respiratory (mask) hearing and eye protection equipment when operating the mixer.



- **NEVER!** place hands inside the drum while the drum is rotating.

- **NEVER** touch the hot exhaust manifold, muffler or cylinder. Allow these parts to cool before servicing engine or mixer.



- **High Temperatures** – Allow the engine to cool before adding fuel or performing service and maintenance functions. Contact with *hot* components can cause serious burns.

- The engine of this mixer requires an adequate free flow of cooling air. **NEVER!** operate the mixer in any enclosed or narrow area where free flow of the air is restricted. If the air

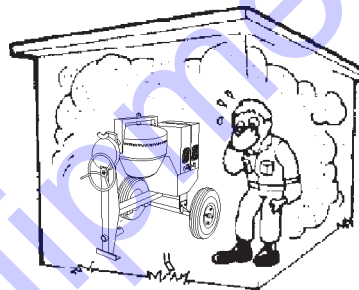

flow is restricted it will cause serious damage to the mixer or engine and may cause injury to people and property. Remember the mixer's engine (gasoline models only) gives off **DEADLY** gases.

- **ALWAYS** refuel in a well-ventilated area, away from sparks and open flames.

- **ALWAYS** use extreme caution when working with **flammable** liquids. When refueling, **stop the** engine and allow it to cool. **DO NOT** smoke around or near the machine. Fire or explosion could result from fuel vapors, or if fuel is spilled on a hot engine.

- **NEVER** operate the mixer in an explosive atmosphere or near combustible materials. An explosion or fire could result causing severe **bodily harm or even death**.

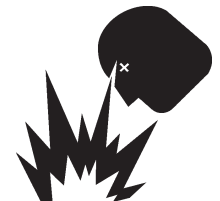

- Topping-off to filler port is dangerous, as it tends to spill fuel.

- Refer to the **Engine Owner's Manual** for engine technical questions or information.

- **NEVER** use accessories or attachments, which are not recommended by Multiquip for this equipment. Damage to the equipment and/or injury to user may result.

- Manufacturer does not assume responsibility for any accident due to equipment modifications.

MC-44S CONCRETE MIXER — RULES FOR SAFE OPERATION

- **NEVER** run engine without air cleaner. Severe engine damage may occur.
- **ALWAYS** read, understand, and follow procedures in Operator's Manual before attempting to operate equipment.
- **ALWAYS** be sure the operator is familiar with proper safety precautions and operations techniques before using roller.
- **ALWAYS** store equipment properly when it is not being used. Equipment should be stored in a clean, dry location out of the reach of children.
- **NEVER** leave the mixer unattended, turn off engine or electric motor when unattended.
- **CAUTION** must always be observed while servicing this mixer. Rotating parts can cause injury if contacted.
- Unauthorized equipment modifications will void all warranties.
- Ensure that any extension cable is protected against damage and not liable to be tripped over or trapped underneath the mixer.
- **DO NOT** allow extension cord to come into contact with water or fluids.
- **DO NOT** spray water onto electric motor.
- This mixer is intended for the production of concrete. Mixer must be used only for its intended purpose.
- This mixer is not suitable for the mixing of **flammable** or **explosive** substances.
- **NEVER** operate the mixer in an **explosive** atmosphere.
- Before starting the mixer, check that all **guards** are in position and correctly fitted.
- Keep area around the mixer **clear of obstructions** which could cause persons to fall onto **moving parts**.
- **ALWAYS** ensure mixer is on level ground before mixing.
- Become familiar with the controls of the mixer before operating.
- **ALWAYS** replace any worn or damaged warning decals.
- Ensure the drum is **rotating** while filling and emptying the drum.
- **ALWAYS** disconnect AC power plug from power source before moving mixer (electric model only).
- **High Temperatures** – Always stop engine and allow the engine to cool before adding fuel, oil or performing service and maintenance functions. Contact with **hot** components can cause serious burns.

- **NEVER** disconnect any "**emergency or safety devices**". These devices are intended for operator safety. Disconnection of these devices can cause severe injury, bodily harm or even death! Disconnection of any of these devices will void all warranties.
- If mixer is equipped with an electric motor, operate electric motor only at the specified voltage indicated on the nameplate.
- Make sure the **OFF/ON** power switch on the electric motor is **always** in the **OFF** position before inserting the mixer's power plug into an AC receptacle (electric model only).

Maintenance Safety

- **NEVER** lubricate components or attempt service on a running machine.
- **ALWAYS** allow the machine a proper amount of time to cool before servicing.
- Keep the machinery in proper running condition.
- Fix damage to the machine immediately and always replace broken parts, or missing decals.
- Dispose of hazardous waste properly. Examples of potentially hazardous waste are used motor oil, fuel and fuel filters.
- **DO NOT** use food or plastic containers to dispose of hazardous waste.
- **DO NOT** pour waste, oil or fuel directly onto the ground, down a drain or into any water source.

Emergencies

- **ALWAYS** know the location of the nearest **fire extinguisher** and **first aid kit**.



- In emergencies **always** know the location of the nearest phone or **keep a phone on the job site**. Also know the phone numbers of the nearest **ambulance**, **doctor** and **fire department**. This information will be invaluable in the case of an emergency.



MC-44S CONCRETE MIXER — OPERATION AND SAFETY DECALS

Machine Safety Decals

The **Multiquip MC-44S** mixer is equipped with a number of safety decals (Figure 1A). These decals are provided for operator safety and maintenance information. The illustration below and on the next page shows these decals as they appear on the machine. Should any of these decals become unreadable, replacements can be obtained from your dealer.



P/N: 13118



CONTACT MQ PARTS
DEPARTMENT



P/N: 512910

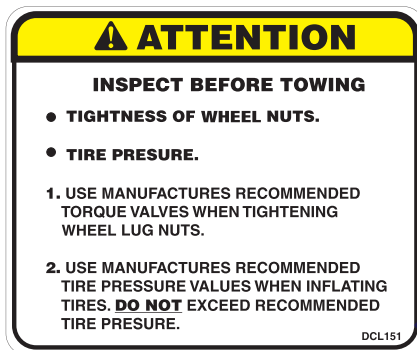

P/N: DCL151



P/N: CIPDCL160

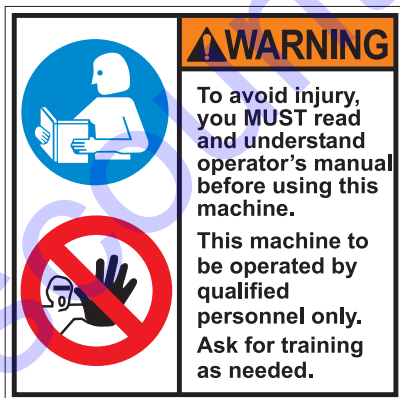

P/N: 35137



P/N: EM948630

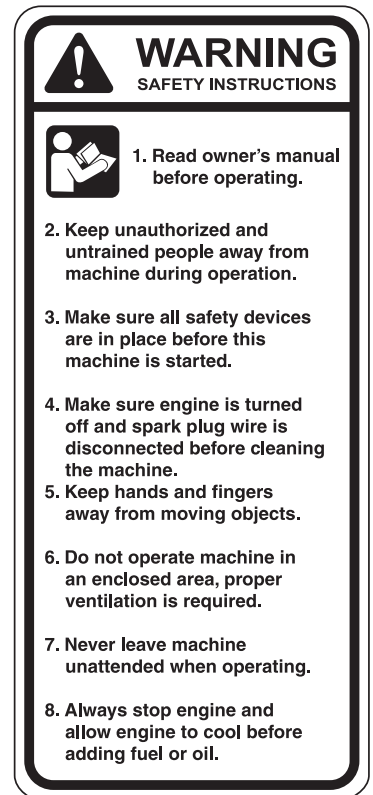

P/N: 504713

Figure 1A. MC-44S Mixer Decals

MC-44S CONCRETE MIXER — GENERAL INFORMATION

Application

This mixer is **only** intended for the production of **concrete**. The mixer must be used for its intended purpose and is not suitable for the mixing of **flammable** or **explosive** substances. The mixer **must not be used** in an explosive atmosphere. Use Table 4 (Mixing Hints) as a guide when mixing concrete for various applications.

Power Plants

The **Multiquip MC42-S** mixer can be powered by either a Honda GX120K1QX2 air-cooled, 4-stroke gasoline engine or a 1/2 HP electric motor. Refer to Table 2 for specific engine or electric motor data information.

Electrical

If mixer is equipped with an **electric motor**, make sure that the power being supplied to the motor corresponds to the voltage rating label on the motor. Supplying the wrong voltage to the electric motor will cause severe electrical damage to the motor.

Always make sure the **OFF/ON** switch on the electric motor is in the **OFF** position before applying power.

It is **strongly recommended** when inserting the mixer's power cord into a receptacle, that a G.F.C.I. (**Ground Fault Current Interrupter**) receptacle be used (115 VAC applications).

Extension Cables

The extension cable should be a 3-wire configuration that includes a ground wire that conforms to UL code. The wire cross section must be a minimum of 2.5 mm². Choose an extension cord of adequate current carrying capacity as referenced in Table 5. Remember **distance** affects the wire size of the extension cable.

Ensure that the extension cable is carefully laid out avoiding **wet areas**, **sharp edges** and locations where vehicles might run over it. Avoid allowing the extension cable to be trapped underneath the mixer.

Unroll the extension cable fully or it will overheat and could catch fire. Make sure that all extension cable connections are dry and safe. Replace any defective or badly worn extension cable immediately.

Hardware

Check all hardware on the mixer before starting. Periodically inspect all hardware. Loose hardware can contribute to early component failure and poor performance. Use Table 3 as general guideline when the torquing of mixer hardware is required. Remember to keep all mixer hardware components tight.

Hardware Diameter	Torque (ft-lbs)
5/16-inch x 18	14
3/8-inch x 16	24
3/8-inch x 24	37
1/2-inch x 13	39
1/2-inch x 13 (Grade 8)	90

Engine Maintenance

For basic engine maintenance, refer to the engine maintenance section in this manual. For a more detailed engine maintenance, refer to the **Honda** Engine Owner's manual furnished with the engine.

APPLICATIONS	MIX RATIOS	BATCH QUANTITIES					APPROX. BATCH OUTPUT	
		CEMENT 112 lbs. (50 Kgs.) Bag	SAND		STONE		CU. FT.	LTR
			CU. FT.	LTR	CU. FT.	LTR		
Most Ordinary	1:2:4	1/2 BAG	1-1/4	35	2-1/2	71	3	85
Foundations	1:3:6	1/3 BAG	1-1/4	35	2-1/2	71	2-3/4	78
Rough Mass Concrete	1:4:8	1/4 BAG	1-1/4	35	2-1/2	71	2-3/4	78
Watertight Floors, Tanks, Pits, Etc.	1:1-1/2:3	2/3 BAG	1-1/4	35	3	71	3	85

MC-44S CONCRETE MIXER — MIXER BASIC COMPONENTS

Figure 2. Mixer Major Components

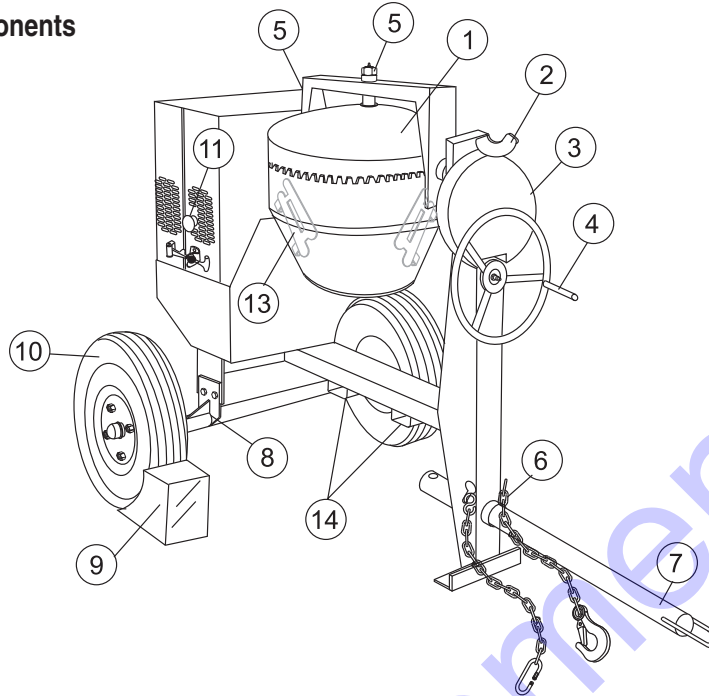

1. **Steel Mixing Drum** — The Multiquip MC-44S concrete mixer uses a 4 cu. ft **steel** mixing drum. This drum is to be used for mixing of concrete. Always clean the drum after each use. **DO NOT** use this mixing drum for the mixing of volatile liquids.
2. **Dump Latch** — To rotate the mixing drum, this latch must be in the up position. To lock the drum, place the latch in the down position.
3. **Dump Gear Guard** — **NEVER** operate the mixer with this guard removed. Its purpose is to prevent dirt and debris from entering the dump gear. In addition operator clothing could become entangled in the dump gear, causing severe injury and bodily harm.
4. **Handwheel** — Turn this wheel clockwise or counter-clockwise to rotate the mixing drum. Remember the dump latch must be in the **up position** in order for the mixing drum to be rotated.
5. **Zerk Fittings** — There is, at the bottom and engine side of the **yoke**, and center of the **handwheel** grease zerk fittings. Lubricate these fittings as referenced in the maintenance section of this manual.
6. **Safety Chain** — This mixer uses a 3/16-inch thick, 72-inches long zinc-plated safety chain. **ALWAYS** connect the safety chain when towing.
7. **Tow Bar** — This mixer uses various towing bars, please reference the frame assembly drawing and parts list in this manual to determine which tow bar meets your requirements.
8. **Rigid Suspension** — This mixer uses a rigid type suspension. Check the mounting hardware for bolt hole elongation and tightness. See maintenance section of this manual for recommended maintenance.
9. **Chock Blocks** — Place these blocks (not included as part of the mixer package) under each mixer wheel to prevent rolling, when mixer is not connect to the towing vehicle.
10. **Tires Ply** — The tire ply (layers) number is rated in letters; This mixer uses 13-inch 2-ply tires. Replace with only recommended type tires.
11. **ON/OFF Switch (gasoline only)** — This switch is provided on *mixer with gasoline* engines only and is located on the side of the mixer frame. When activated it will shut down the engine. Pull out when starting the engine.
12. **Cabinet/Latch** — Encloses engine and electric motor. **NEVER** run mixer with cabinet removed. Use latches to secure engine compartment cabinet.
13. **Mixing Blades (Steel)** — Used for the mixing of concrete. When blades show signs of wear, entire steel mixing drum assembly must be replaced. See steel mixing drum assembly in the parts section of this manual.
14. **Forklift Pockets** — When lifting of the mixer is required, use these fork lift pockets to lift the mixer. Remember to insert the forks of the forklift a minimum of 24 inches into the lift pockets.

MC-44S CONCRETE MIXER — BASIC ENGINE COMPONENTS

Honda GX Series Engine Shown

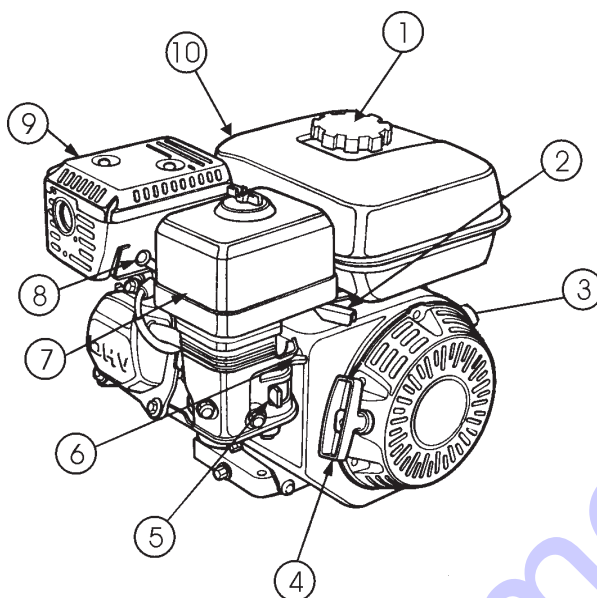

Figure 3. Engine Controls and Components

INITIAL SERVICING

The engine (Figure 3) must be checked for proper lubrication and filled with fuel prior to operation. Refer to the manufacturers Engine manual for instructions & details of operation and servicing.

1. **Fuel Filler Cap** – Remove this cap to add unleaded gasoline to the fuel tank. Make sure cap is tightened securely. **DO NOT** over fill.



WARNING

Adding fuel to the tank should be accomplished only when the engine is stopped and has had an opportunity to cool down. In the event of a fuel spill,

DO NOT attempt to start the engine until the fuel residue has been completely wiped up, and the area surrounding the engine is dry.

2. **Throttle Lever** – Used to adjust engine RPM speed (lever advanced forward **SLOW**, lever back toward operator **FAST**).
3. **Engine ON/OFF Switch** – ON position permits engine starting, OFF position stops engine operations.
4. **Recoil Starter (pull rope)** – Manual-starting method. Pull the starter grip until resistance is felt, then pull briskly and smoothly.

5. **Fuel Valve Lever** – **OPEN** to let fuel flow, **CLOSE** to stop the flow of fuel.
6. **Choke Lever** – Used in the starting of a cold engine, or in cold weather conditions. The choke enriches the fuel mixture.
7. **Air Cleaner** – Prevents dirt and other debris from entering the fuel system. Remove wing-nut on top of air filter cannister to gain access to filter element.

NOTE

Operating the engine without an air filter, with a damaged air filter, or a filter in need of replacement will allow dirt to enter the engine, causing rapid engine wear.

8. **Spark Plug** – Provides spark to the ignition system. Set spark plug gap to 0.6 - 0.7 mm (0.028 - 0.031 inch). Clean spark plug once a week.
9. **Muffler** – Used to reduce noise and emissions.



WARNING

Engine components can generate extreme heat. To prevent burns, **DO NOT** touch these areas while the engine is running or immediately after operating. **NEVER** operate the engine with the muffler removed.

10. **Fuel Tank** – Holds unleaded gasoline. For additional information refer to engine owner's manual.

MC-44S CONCRETE MIXER — HANDWHEEL ASSEMBLY

Assembly

The Multiquip MC-44S concrete mixer is shipped with the handwheel detached. Attach the handwheel to the mixer as shown in Figure 4.

STEP 1.
CUT TY-BAND SECURING
DUMP LATCH AND HANDWHEEL.

STEP 2.
REMOVE SNAP RING.
USE SNAP RING TOOL

SQUEEZE
HANDLES
TO OPEN
SNAP RING

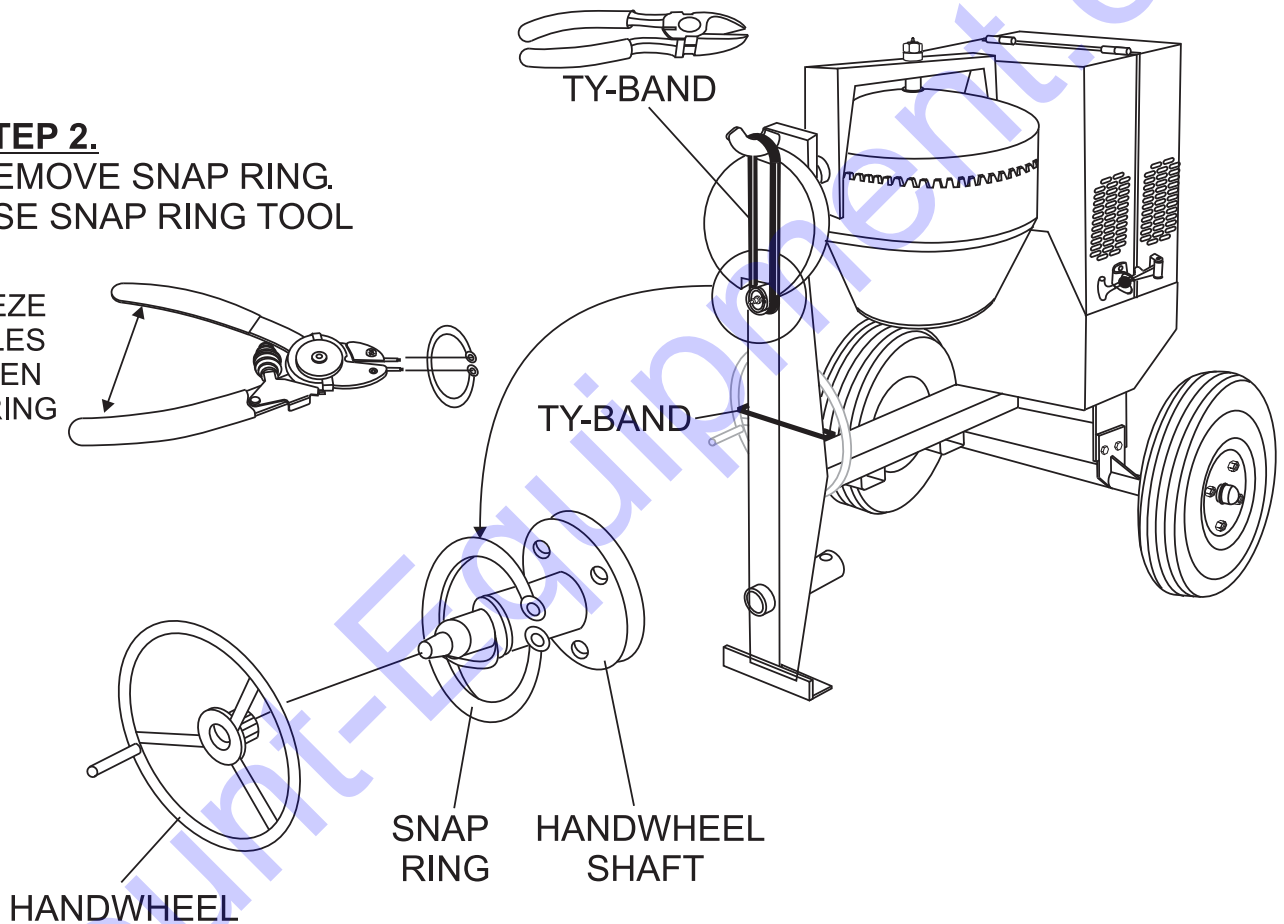

STEP 3.
PLACE HANDWHEEL
ONTO HANDWHEEL-
SHAFT.

STEP 4.
RE-INSTALL SNAP
RING BACK ONTO
HANDWHEEL SHAFT.

Figure 4. Handwheel Assembly

MC-44S CONCRETE MIXER — TOWING GUIDELINES

Towing Safety Precautions

CAUTION:



- Check with your county or state safety towing regulations department before towing your *mixer*.

To reduce the possibility of an accident while transporting the mixer on public roads, always make sure that the mixer towing components and the towing vehicle are in good operating condition and both units are mechanically sound.

The following list of suggestions should be used when towing the mixer:

- Make sure that the hitch and coupling of the towing vehicle are rated equal to, or greater than the trailer "gross vehicle weight rating" (GVWR).
- **ALWAYS** inspect the hitch and coupling for wear. **NEVER** tow the mixer with defective hitches, couplings, chains etc.
- **CHECK** the tire air pressure on both the towing vehicle and the trailer. Also check the tire tread wear on both vehicles.
- **ALWAYS** make sure the mixer is equipped with a "Safety Chain".
- **ALWAYS** attach trailer's safety chain to the frame of towing vehicle.
- **ALWAYS** make sure that the towing vehicle's directional, backup, and brake lights are working properly.
- Remember in most cases the maximum speed unless otherwise posted for highway towing is 45 MPH, however before towing your mixer, check your local state, and county vehicle towing requirements. Recommended off-road towing is not to exceed **10 MPH** or less depending on type of terrain.
- Place *chocked blocks* underneath wheels to prevent **rolling**, while parked, if disconnected from towing vehicle.
- Inflate tires to correct pressure, inspect tires for cuts, and excessive wear. See Table 16 (Tire Wear Troubleshooting).
- When towing of the mixer is required, place the drum in the up position (mouth facing upwards).
- **ALWAYS** make sure that the fuel valve lever is in the **OFF** position (gasoline models only).

- Check wheel mounting lug nuts with a **torque wrench**. Torque wheel lug nuts as described in the maintenance section of this manual.
- Check tightness of U-clamp nuts, torque suspension hardware as referenced in the maintenance section of this manual.
- Avoid sudden stops and starts. This can cause skidding, or jackknifing. Smooth, gradual starts and stops will improve gas mileage.
- Avoid sharp turns to prevent rolling.

CAUTION:



If the mixer tow bar is deformed or damaged replace **entire tow bar**. **NEVER** tow the mixer with a defective tow bar. There exist the possibility of the trailer separating from the towing vehicle.

Tow Bar to Vehicle Connection (Coupler Only)

1. Check the vehicle hitch ball, and mixer's coupler for signs of wear or damage. Replace any parts that are worn or damaged before towing.
2. Use only a 2-inch ball diameter (towing vehicle), this will match the mixer's 2-inch coupler. Use of any other ball diameter will create an extremely dangerous condition which can result in separation of the coupler and ball or ball failure.
3. After tow bar has been connected to mixer (see next page), attach mixer's coupler to the hitch ball on the towing vehicle securely and make sure the lock lever is in the down position (locked).

Mixer Tow Bar Vehicle Connection (Pintle and Loop)

1. Make sure the bumper on the towing vehicle is equipped to handle either a pintle or loop type tow bar configuration.
2. After tow bar has been connected to mixer (see next page), secure either type of tow bar to the towing vehicle, following state and county towing regulations.
3. As a minimum, use a 1/2-inch bolt and nylock nut grade 5 when securing either tow bar to the towing vehicle,

MC-44S CONCRETE MIXER — SAFETY CHAIN CONNECTION

CAUTION:



NEVER! tow the mixer with the safety chain removed. The safety chain is intended to prevent complete separation of the mixer from the towing vehicle in the event of a tow bar failure.

Reference Figure 5 for the installation of the **Safety Chain**.

Tow Bar to Mixer Connection

1. Insert the tow bar through the round opening at the bottom of the mixer stand.

Align the hole on the tow bar with the hole on the mixer frame, and insert 1/2-inch bolt through tow bar and frame. Secure tow bar to frame with 1/2-inch nylock nut. Tighten to 40 ft.-lbs.

2. Route the safety chain through the holes just above the tow bar, located on each side of the mixer stand.

Loop the chain together and place under the tow bar. Secure the loop with the connector link.
3. Extend the safety chain along the length of the tow bar, looping it through the tow bar's connector link. Remove any excess chain slack.
4. Connect the free end of (clevis safety hook) the safety chain to the towing vehicle. **Remember it is critical that the length of the chain be properly adjusted,** to prevent the **draw bar** and the front of the mixer stand from dropping to the the ground (contact) in the event the draw bar becomes disconnected from the towing vehicle.

Figure 5. Tow Bar and Safety Chain Installation

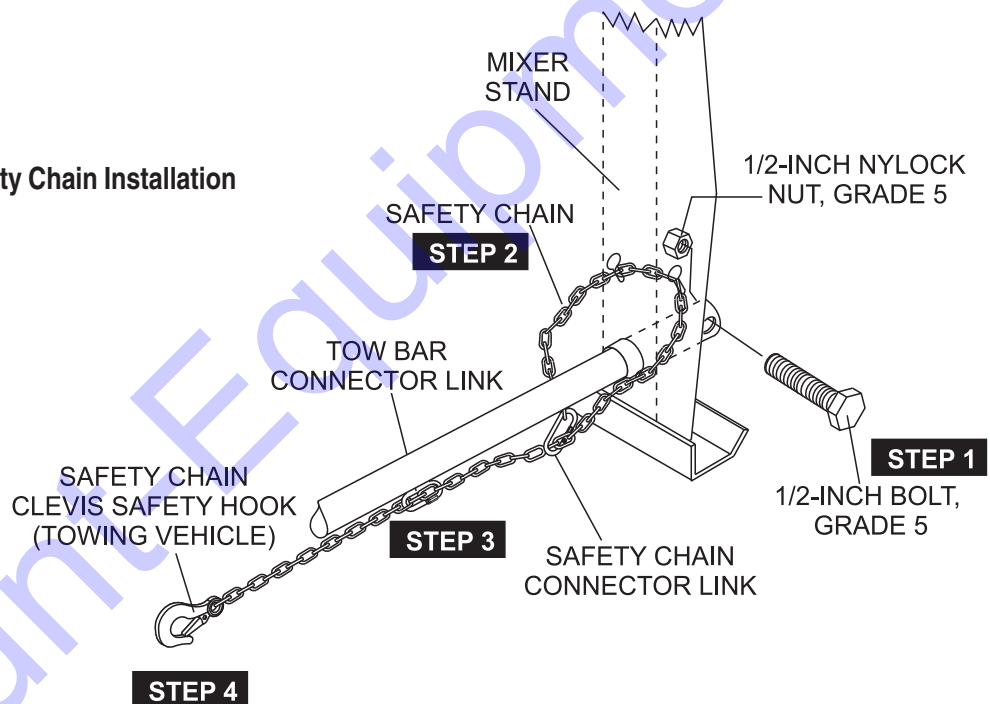

OPTIONAL TOW BARS

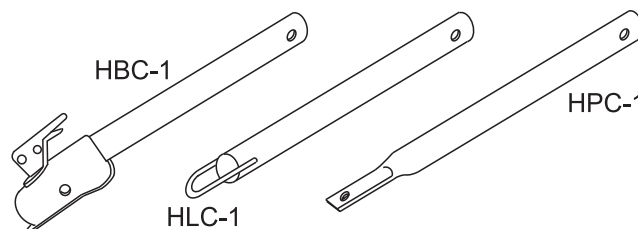

MC-44S CONCRETE MIXER — ELECTRIC MOTOR

Electric Motor

For maintenance care and operation of the electric motor, refer to your electric motor instruction booklet furnished with the electric motor.

Protect the electric motor from dust as much as possible and keep ventilating openings clean.

CAUTION:



- **DO NOT** spray water at any time on the *electric motor*.
- **DO NOT** operate electric motor in a explosive environment.

The electric motor used in this mixer is a single-phase 1.5 HP motor. The input voltage requirement for this motor is either 115 or 230 VAC only.

Electric Motor Connection

A 12 inch electrical cable (Figure 2) with a pigtail at one end is provided with the electrical motor for hookup to a power source. Table 1. shows the required NEMA connector for the desired motor horsepower rating. In addition, Table 2 also shows the matching NEMA approved connector for the required extension cord.

ALWAYS, make certain that the power source required for the electric motor is **correct** and always use the correct NEMA configuration plug. **Failure** to supply the correct voltage to the motor can severely damage the motor.

The electric motor supplied with the mixer is configured from the factory for 115VAC grounded operation. Make certain that the correct size grounded (3-wires) extension cord is used. See Table 5.

Motors can burn out when the line voltage falls 10% below the voltage rating of the motor. Failure to use proper voltage will cause the motor to overheat and actuate the overload switch.

If overload protection should actuate because of improper voltage or any other malfunction, turn the main switch on the motor to the "OFF" position and correct the problem, press the reset switch button, and turn the main switch to the "ON" position.

Table 5. Recommended Extension Cord Sizes

Electric Motor	Input Voltage	50 ft. (15.24 m)	75 ft. (22.86 m)	100 ft. (30.48 m)	200 ft. (60.96 m)
1/2 HP	115 VAC	No. 12	No. 10	No. 8	No. 6

Electric Motor Voltage Change Switch

1. **ALWAYS** make certain the electric motor's **ON/OFF** switch is in the "OFF" position and the power cord has been disconnected from the power source.

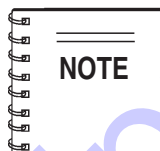

NEVER! *disable or disconnect the ON/OFF switch on the electric motor. It is provided for operator safety. Injury may result if it is disable, disconnected or improperly maintained.*

MC-44S CONCRETE MIXER — ELECTRIC MOTOR

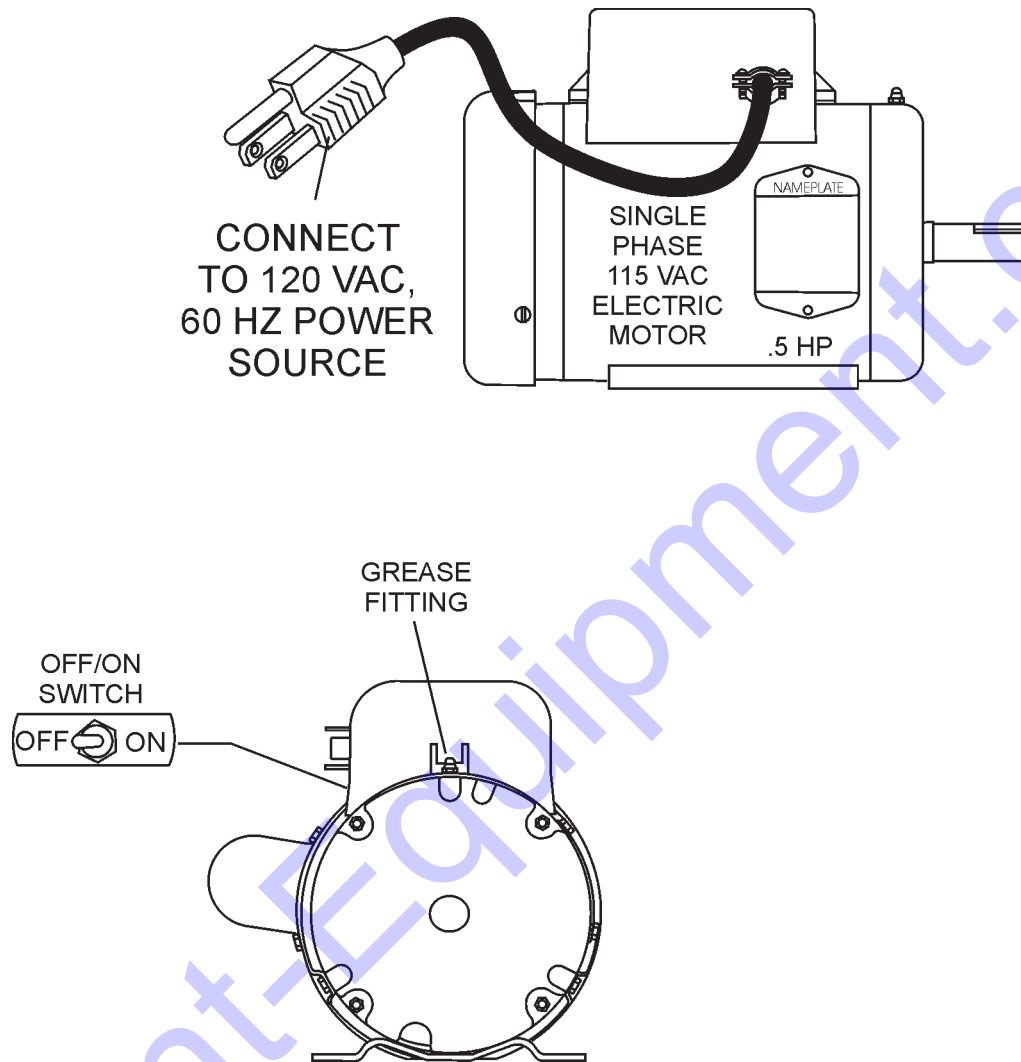

Figure 6. Single Phase Electric Motor with 12 inch Pigtail Cable

MC-44S CONCRETE MIXER — PRE-INSPECTION (GAS ENGINE)

Before Starting

1. Read safety instructions at the beginning of manual.
2. Clean the **mixer**, removing dirt and dust, particularly the engine cooling air inlet, carburetor and air cleaner.
3. Check the air filter for dirt and dust. If air filter is dirty, replace air filter with a new one as required.
4. Check carburetor for external dirt and dust. Clean with dry compressed air.
5. Check fastening nuts and bolts for tightness.

Engine Oil Check



1. To check the engine oil level, place the mixer on secure level ground with the engine stopped.
2. Remove the filler dipstick from the engine oil filler hole (Figure 7) and wipe it clean.

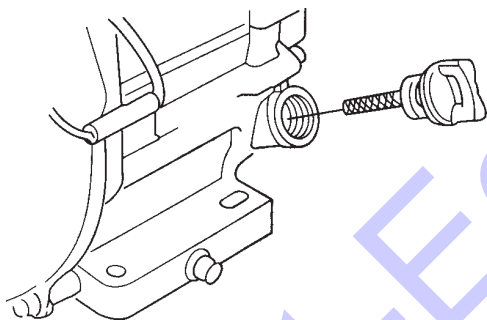

Figure 7. Engine Oil Dipstick (Removal)

3. Insert and remove the dipstick without screwing it into the filler neck. Check the oil level shown on the dipstick.
4. If the engine oil level is low (Figure 8), fill to the edge of the oil filler hole with the recommended oil type (Table 6). See Table 2 for the oil capacity of your type engine.

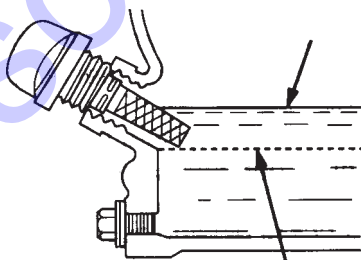

Figure 8. Engine Oil Dipstick (Oil Level)

Table 6. Oil Type

Season	Temperature	Oil Type
Summer	25°C or Higher	SAE 10W-30
Spring/Fall	25°C~10°C	SAE 10W-30/20
Winter	0°C or Lower	SAE 10W-10

Explosive Fuel



Fuel Check

If your mixer has a gasoline engine, determine if the engine fuel is low. If fuel is low, remove the fuel filler cap and fill with **unleaded** gasoline. Motor fuels are highly flammable and can be dangerous if mishandled. **DO NOT** smoke while refueling. **DO NOT** attempt to refuel the trowel if the engine is **hot!** or **running**.

1. Remove the gasoline cap located on top of fuel tank.
2. Visually inspect to see if fuel level is low. If fuel is low, replenish with unleaded fuel.
3. When refueling, be sure to use a strainer for filtration. **DO NOT** top-off fuel. Wipe up any spilled fuel.

V-belt Check

A worn or damaged V-belt can adversely affect the performance of the mixer. If a V-belt is defective or worn simply replace the V-belt as outlined in the maintenance section of this manual.

Blade Check

Check for worn blades. If using a steel tub and the blades are worn, replace the entire tub assembly. Remember the blades are welded to tub.

If using a plastic tub, replace the blades using the part numbers referenced in the parts section of this manual.

Start/Stop Switches

This mixer has been equipped with a start/stop switches for both the gasoline and electric motor mixers. These switches should be tested every time the engine or motor is started.

Grease Fittings (Zerk)

Check the zerk grease fittings (Figure 26) as shown in the maintenance section of this manual. These grease fittings lubricate the **handwheel** and the **yoke mechanism**.

MC-44S CONCRETE MIXER — INITIAL START-UP (GAS ENGINE)

Starting the Engine (Gasoline Only)

The following steps outline the procedure for starting the engine. Depending on the type of engine employed in the mixer the steps may vary slightly. If your mixer has an electric motor disregard this section.

1. Move the fuel shut-off lever (Figure 9) to the **ON** position.

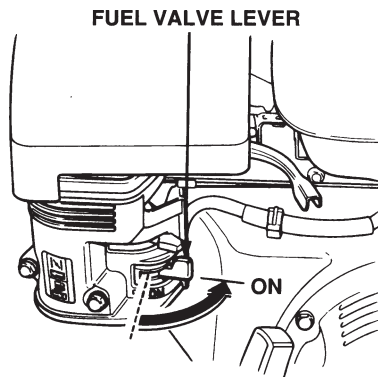

Figure 9. Fuel Shut-Off Lever

2. To start a cold engine, move the choke lever (Figure 10) to the **CLOSED** position.

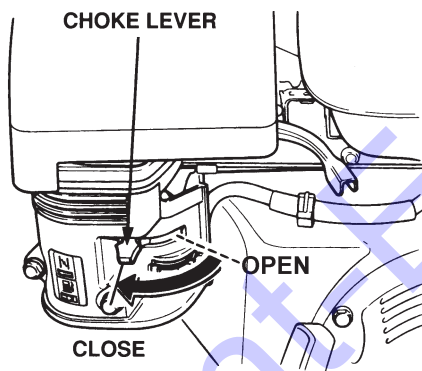

Figure 10. Choke Lever

3. Move the throttle lever (Figure 11) away from the slow position, about 1/3 of the way toward the fast position.

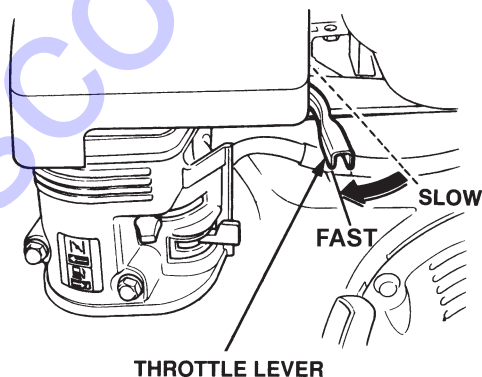

Figure 11. Throttle Lever

4. Turn the engine switch (Figure 12) to the **ON** position.

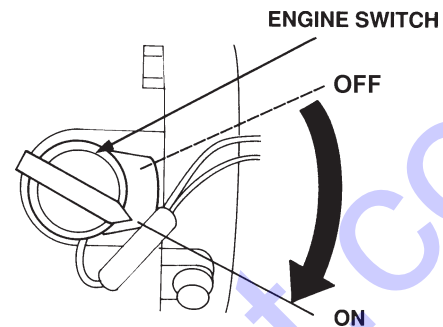

Figure 12. Engine ON/OFF Switch

5. Located at the rear of the mixer frame is the main **start/stop** button (Figure 13). Pull this button outward to start the engine.

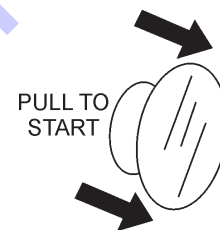

Figure 13. Engine Start/Stop Button

6. Pull the **starter grip** (Figure 14) lightly until you feel resistance, then pull briskly. The drum should be rotating at this time.

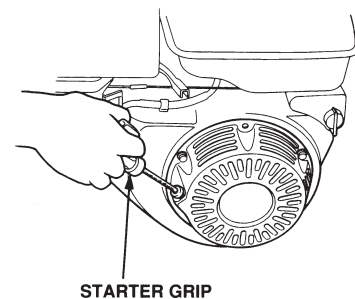

Figure 14. Starter Grip

MC-44S CONCRETE MIXER — INITIAL START-UP (ELECTRIC MOTOR)

Initial Start-up Instructions (Electric Motor)

Starting

CAUTION:



DO NOT attempt to operate the mixer until the Safety, General Information and Inspection sections have been read and understood.

1. Before starting, make sure mixer is positioned on a secure flat surface to prevent rolling.
2. Use an extension cord (see Table 5) of adequate current carrying capacity, insert the electric motor's power plug into one end of the extension cord.
3. **NEVER!** use a *worn* or *frayed* extension cord.
4. **NEVER!** operate mixer with V-belt cover removed.

DANGER



NEVER! touch the power cord (Figure 15) with *wet hands* or while *standing in water* when it is connected to a power source. The possibly exists of electrical shock (electrocution) even death. **NEVER!** spray water directly on the electric motor.

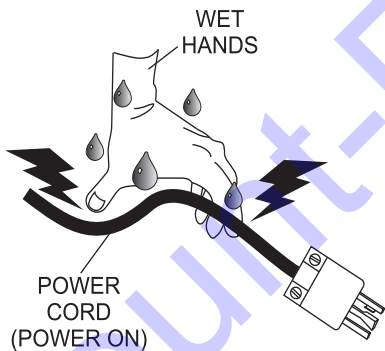
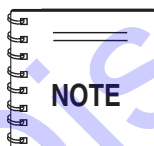

Figure 15. Extension Cord (Wet Hands)



To prevent personnel from tripping over the extension cord, position the extension cord so that it lays flat and is not curled underneath the mixer.

5. Plug the other end of the extension cord into a 120 VAC G.F.C.I. protected receptacle. Remember the power requirements for this electric motor is 120 VAC, 60 Hz. The use of any other input voltage will severely damage the motor.

CAUTION:

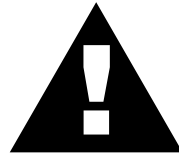

ALWAYS read the label on the electric motor before applying power. The label will indicate the proper power requirements for the motor. Remember the use of any other input voltage will severely damage the motor.

CAUTION:



To prevent tripping (Figure 16) of personnel, position the extension cord so that it lays flat and is not curled underneath the mixer.

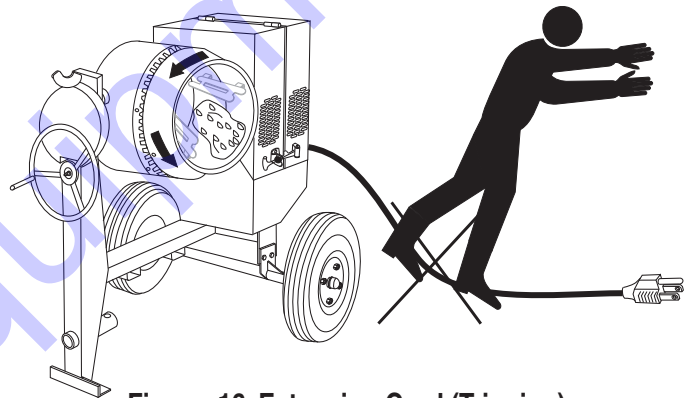

Figure 16. Extension Cord (Tripping)

WARNING:



ALWAYS read the label on the electric motor before applying power. The label will indicate the correct power requirements for the motor. Remember the use of an incorrect input voltage will severely damage the electric motor.

Starting the Electric Motor

1. Set the electric motor's **ON/OFF** switch (Figure 17) to the **ON** position.

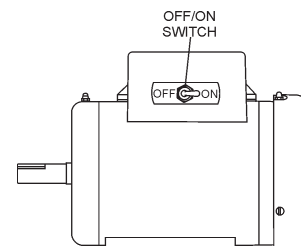

Figure 17. Electric Motor ON/OFF Switch (ON Position)

MC-44S CONCRETE MIXER — OPERATION

Operation

1. To position the tub, make sure the mixer is placed on firm level ground, then **pull up** on the **dump latch** (Figure 18) and turn the **hand wheel** until the tub is at the desired position. Once the tub is at the desired position, **pull down** on the dump latch to lock the tub in position.

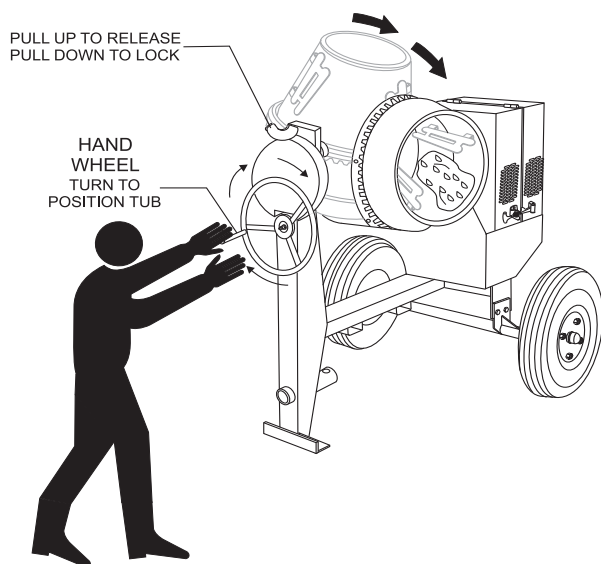

Figure 18. Mixing Drum Positioning

CAUTION:



NEVER stand in front or behind the mixing drum while it is being placed in the dump position. Stay clear of the mixing drum while it is being positioned.

2. As the drum rotates, use a shovel (Figure 19) to place the cement mix inside the drum, add water as required. Be careful to only place the **tip** of the shovel inside the drum.

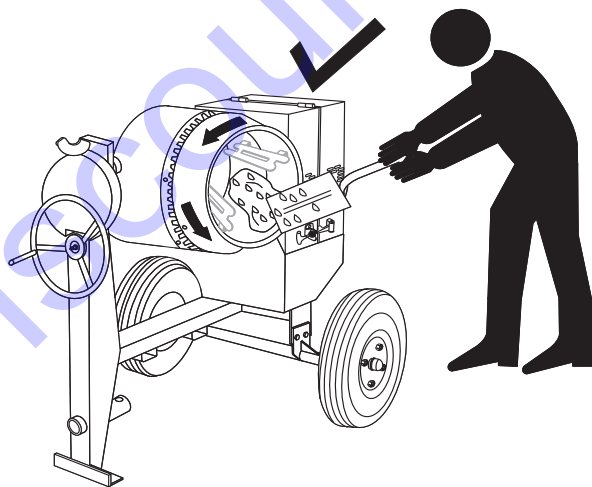

Figure 19. Filling Mixing Drum

3. Placing the shovel all the way inside the drum (Figure 20) will cause the shovel to strike the blades. This condition will make the shovel rotate, and could cause injury to personnel. **NEVER** place hands inside the mixing drum while it is rotating.

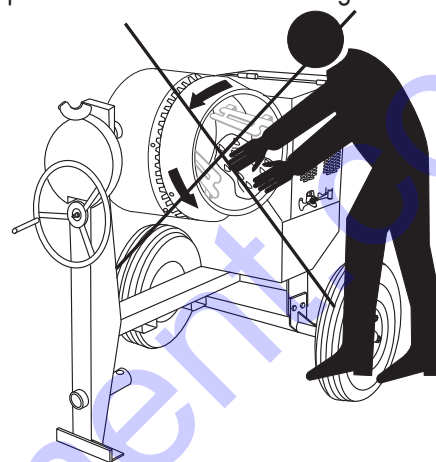

Figure 20. Filling Mixing Drum

Stopping the Mixer (Gasoline)

1. Push the main **start/stop** switch (Figure 21) inward to stop the engine.

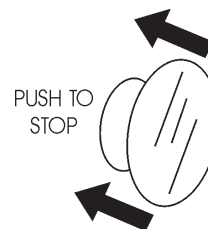

Figure 21. Start/Stop Button (Stop Position)

2. Place fuel shut-off lever in the **OFF** position.
3. Clean drum of all debris and foreign matter.

Stopping the Mixer (Electric)

1. Place the electric motor's **ON/OFF** switch (Figure 22) in the **OFF** position.

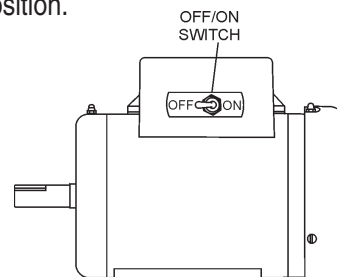

Figure 22. Electric Motor ON/OFF Switch (OFF Position)

2. Disconnect the electric motor's extension cord from its power source.
3. Clean drum of all debris and foreign matter.

MC-44S CONCRETE MIXER — MAINTENANCE (ENGINE)

Use Table 7 as a general maintenance guideline when servicing your engine. For more detail engine maintenance information, refer to the engine owner's manual supplied with your engine.

Table 7. Engine Maintenance Schedule

DESCRIPTION (3)	OPERATION	BEFORE	FIRST MONTH OR 10 HRS.	EVERY 3 MONTHS OR 25 HRS.	EVERY 6 MONTHS OR 50 HRS.	EVERY YEAR OR 100 HRS.	EVERY 2 YEARS OR 200 HRS.
Engine Oil	CHECK	X					
	CHANGE		X				
Air Cleaner	CHECK	X					
	CHANGE			X (1)			
All Nuts & Bolts	Re-tighten If Necessary	X					
Spark Plug	CHECK-CLEAN				X		
	REPLACE						X
Cooling Fins	CHECK				X		
Spark Arrester	CLEAN					X	
Fuel Tank	CLEAN					X	
Fuel Filter	CHECK					X	
Idle Speed	CHECK-ADJUST					X (2)	
Valve Clearance	CHECK-ADJUST						X (2)
Fuel lines	CHECK	Every 2 years (replace if necessary) (2)					

(1) Service more frequently when used in **DUSTY** areas.

(2) These items should be serviced by your service dealer, unless you have the proper tools and are mechanically proficient. Refer to the HONDA or ROBIN Shop Manual for service procedures.

(3) For commercial use, log hours of operation to determine proper maintenance intervals.

MC-44S CONCRETE MIXER — MAINTENANCE (ENGINE)

Maintenance

Perform the scheduled maintenance procedures as defined by Table 6 and below:

DAILY

- Thoroughly remove dirt and oil from the engine and control area. Clean or replace the air cleaner elements as necessary. Check and retighten all fasteners as necessary. Check the gearbox for oil leaks. Repair or replace as needed.

WEEKLY

- Remove the fuel filter cap and clean the inside of the fuel tank.
- Remove or clean the filter at the bottom of the tank.
- Remove and clean the spark plug (Figure 23), then adjust the spark gap to 0.024 ~0.028 inch (0.6~0.7 mm). This unit has electronic ignition, which requires no adjustments.

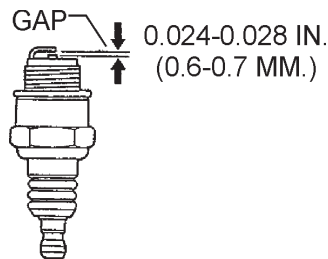

Figure 23. Spark Plug Gap

ENGINE OIL

- Drain the engine oil when the oil is **warm** as shown in Figure 24.
- Remove the oil drain bolt and sealing washer and allow the oil to drain into a suitable container.
- Replace engine oil with recommended type oil as listed in Table 6. For engine oil capacity, see Table 2 (engine specifications). **DO NOT** overfill.
- Install drain bolt with sealing washer and tighten securely.

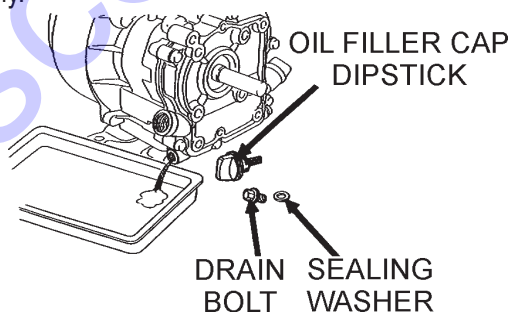
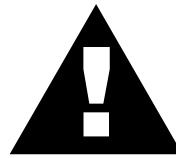

Figure 24. Engine Oil (Draining)

DANGER :



DO NOT use gasoline as a cleaning solvent, because that would create a risk of fire or explosion.

ENGINE AIR CLEANER

- Remove the air cleaner cover and foam filter element as shown in Figure 25.
- Tap the paper filter element (Figure 34) several times on a hard surface to remove dirt, or blow compressed air [not exceeding 30 psi (207 kPa, 2.1 kgf/cm²)] through the filter element from the air cleaner case side. **NEVER** brush off dirt. Brushing will force dirt into the fibers. Replace the paper filter element if it is excessively dirty.
- Clean foam element in warm, soapy water or nonflammable solvent. Rinse and dry thoroughly. Dip the element in clean engine oil and completely squeeze out the excess oil from the element before installing.

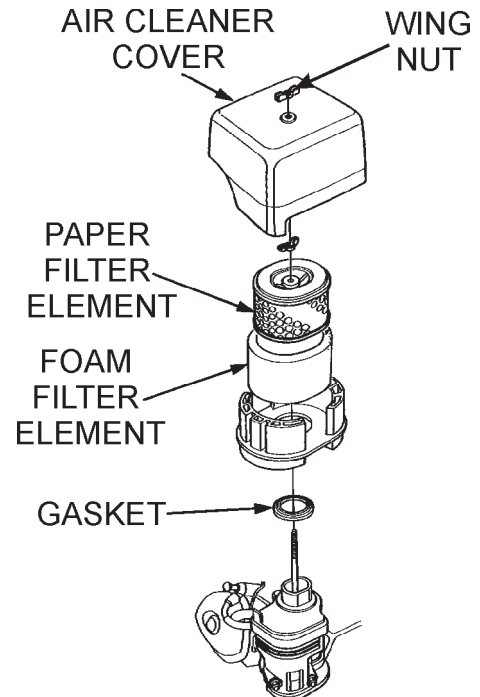

Figure 25. Engine Air Cleaner

MC-44S CONCRETE MIXER — MAINTENANCE (MIXER)

Ball Socket and Clamp Face Maintenance

1. If the towing vehicle is equipped with a ball socket, smear socket periodically with multi-purpose grease. This will keep the ball socket well lubricated.
2. Periodically oil **pivot points** and **clamp face** surfaces of coupler with SAE 30 WT. motor oil.
3. When parking or storing your mixer. Keep the coupler off the ground so dirt will not build up in the ball socket.

Grease Fittings (Zerk) Maintenance (Mixer)

There are 3 grease (Figure 26) fittings that will require lubrication. Lubricate these fittings **once a week**. Use lithium base grease, grade NO.1.

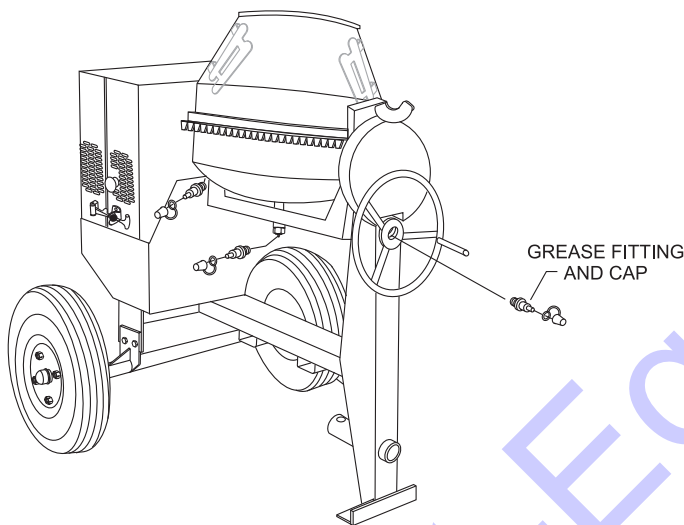

Figure 26. Grease Fittings Mixer

Grease Fittings (Zerk) Maintenance (Electric Motor)

1. There are two grease (Figure 27) fittings at each end of the electric motor that will require lubrication. Lubricate these fittings about **every 16 months**.

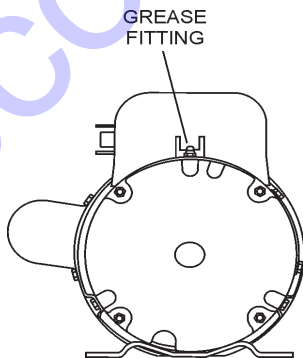

Figure 27. Grease Fittings Electric Motor

2. Use Poleyrex EM (Exxon Mobil) or equivalent lubricant. Clean grease fitting, apply grease gun to fitting (1/2 shot). Remember too much grease or injecting grease too quickly can cause premature bearing failure. Slowly apply the recommended amount of grease, taking a minute or so to apply.

Wheel Bearings

1. After every 3 months of operation, remove the hub dust cap and inspect the wheel bearings (Figure 28). Once a year, or when required, disassemble the wheel hubs remove the old grease and repack the bearings forcing grease between rollers, cone and cage with a good grade of high speed wheel bearing grease (**never** use grease heavier than 265 A.S.T.M. penetration ("No. 2."))

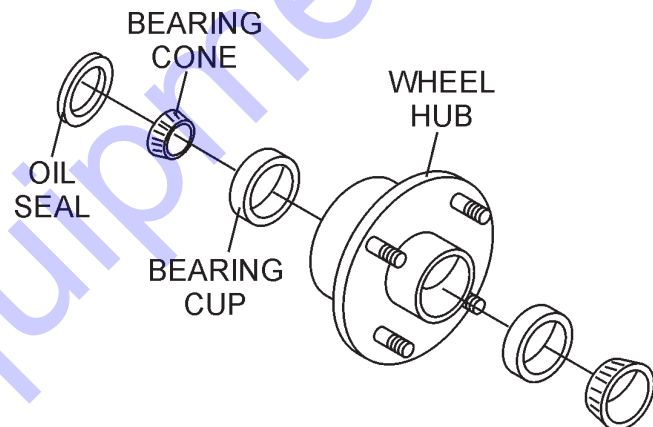

Figure 28. Wheel Hub and Bearings

2. Fill the wheel hub (Figure 28) with grease to the inside diameter of the outer races and also fill the hub grease cap. Reassemble the hub and mount the wheel. Then tighten the adjusting nut, at the same time turn the wheel in both directions, until there is a slight bind to be sure all the bearing surfaces are in contact.

Then back-off the adjusting nut 1/6 to 1/4 turn or to the nearest locking hole or sufficiently to allow the wheel to rotate freely within limits of .001" to .010" end play. Lock the nut at this position. Install the cotter pin and dust cap, and tighten all hardware.

Mixer Cleaning

1. For thorough mix and longer drum life, **always** wash drum out after each use.
2. **NEVER!** pour or spray water over the engine or electric motor.

MC-44S CONCRETE MIXER — MAINTENANCE (MIXER)

Tires/Wheels/Lug Nuts

Tires and wheels are a very important and critical components of the trailer. When specifying or replacing the trailer wheels it is important the wheels, tires, and axle are properly matched.

CAUTION:



DO NOT attempt to repair or modify a wheel. **DO NOT** install an inter-tube to correct a leak through the rim.

If the rim is cracked, the air pressure in the inter-tube may cause pieces of the rim to explode (break-off) with great force and can cause serious eye or bodily injury.

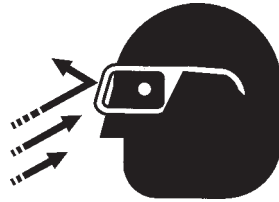

Tires Wear/Inflation

Tire inflation pressure is the most important factor in tire life. Pressure should be checked cold before operation. **DO NOT** bleed air from tires when they are hot. Check inflation pressure weekly during use to insure the maximum tire life and tread wear.

Table 8 (Tire Wear Troubleshooting) will help pinpoint the causes and solutions of tire wear problems.

CAUTION:

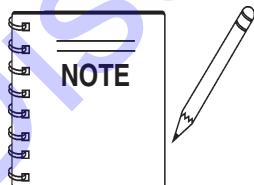
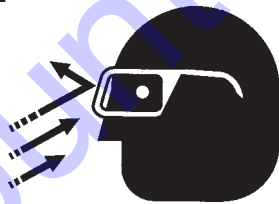

ALWAYS wear safety glasses when removing or installing force fitted parts. Failure to comply may result in serious injury.

TABLE 8. TIRE WEAR TROUBLESHOOTING

WEAR PATTERN	CAUSE	SOLUTION	
	Center Wear	Over Inflation	Adjust pressure to particular load per tire manufacturer.
	Edge Wear	Under Inflation	Adjust pressure to particular load per tire manufacturer.
	Side Wear	Loss of chamber or overloading.	Make sure load does not exceed axle rating. Align wheels.
	Toe Wear	Incorrect toe-in	Align wheels.
	Cupping	Out-of balance	Check bearing adjustment and balance tires.
	Flat Spots	Wheel lockup & tire skidding.	Avoid sudden stops when possible and adjust brakes.

Suspension

The rigid suspension and associated components (Figure 29) should be visually inspected every 6,000 miles for signs of excessive wear, elongation of bolt holes, and loosening of mounting bracket. Replace any damaged suspension component immediately.

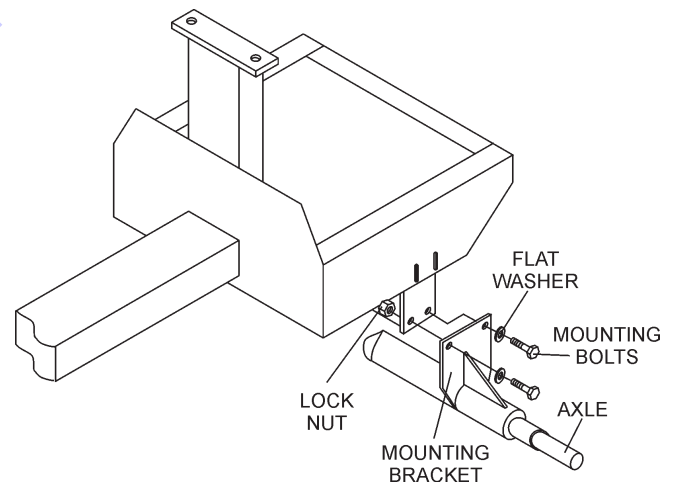
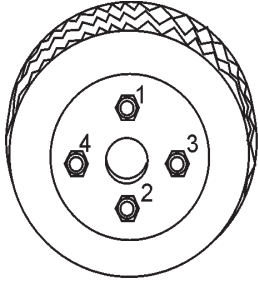
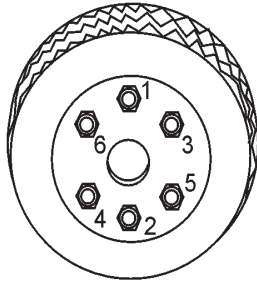

Figure 29. Suspension Components

MC-44S CONCRETE MIXER — MAINTENANCE (MIXER)



4-LUG NUTS



6-LUG NUTS

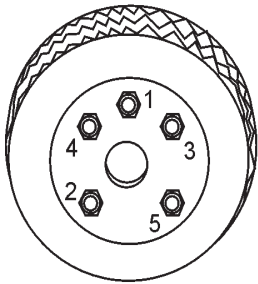

5-LUG NUTS

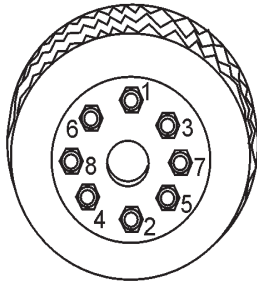

8-LUG NUTS

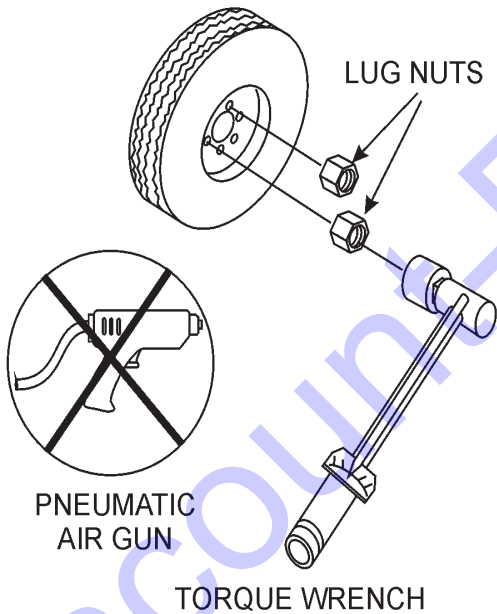
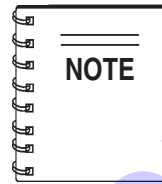

Figure 30. Wheel Lug Nuts Tightening Sequence

Lug Nut Torque Requirements

It is extremely important to apply and maintain proper wheel mounting torque on the trailer. Be sure to use only the fasteners matched to the cone angle of the wheel. Proper procedure for attachment of the wheels is as follows:

1. Start all wheel lug nuts by hand.
2. Torque all lug nuts in sequence. See Figure 30. **DO NOT** torque the wheel lug nuts all the way down. Tighten each lug nut in 3 separate passes as defined by Table 9.
3. After first road use, retorque all lug nuts in sequence. Check all wheel lug nuts periodically.



NEVER! use an pneumatic air gun to tighten wheel lug nuts.

Mixer Storage

For storage of the mixer for over 30 days, the following is recommended:

- Drain the fuel tank completely, or add STA-BIL to the fuel.
- Run the engine until the fuel is completely consumed.
- Completely drain used oil from the engine crankcase and fill with fresh clean oil, then follow the procedures described in the engine manual for engine storage.
- Clean the entire mixer and engine compartment.
- Place the mixing drum in the down position (mouth facing downward).
- Cover the mixer and place it a clean dry area, that is protected from harsh elements.

MC-44S CONCRETE MIXER — TROUBLESHOOTING (ENGINE)

Practically all breakdowns can be prevented by proper handling and maintenance inspections, but in the event of a breakdown, please take a remedial action following the

diagnosis based on the Troubleshooting (Tables 9 and 10) information shown below and on the next page. If the problem cannot be remedied, please leave the unit just as it is and consult our company's business office or service plant.

TABLE 9. ENGINE TROUBLESHOOTING

SYMPTOM	POSSIBLE PROBLEM	SOLUTION
Difficult to start		
Fuel is available but spark plug will not ignite. (Power available at high tension cable).	Ignition plug being bridge?	Check ignition system.
	Carbon deposit at ignition?	Clean or replace ignition.
	Short circuit due to defective insulators?	Replace insulators.
	Improper spark gap?	Set spark plug gap to the correct gap.
Fuel is available but spark plug will not ignite. (Power NOT available at high tension cable).	Short circuit at stop switch?	Check stop switch circuit. Replace stop switch if defective.
	Ignition coil defective?	Replace ignition coil.
Fuel is available and spark plug ignites (compression normal).	Muffler clogged with carbon deposits?	Clean or replace muffler.
	Fuel in use inadequate (water, dust)?	Flush fuel sytem and replace with fresh fuel.
	Air Cleaner clogged?	Clean or replace air cleaner.
Fuel is available and spark plug ignites (compression low).	Defective cylinder head gasket?	Tighten cylinder head bolts or replace head gasket.
	Cylinder worn?	Replace cylinder.
	Spark plug loose?	Tighen spark plug.
Operation not satisfactory		
Not enough power available (compression normal, no miss-firing).	Air cleaner clogged?	
	Air in fuel line?	Bleed (remove air) from fuel line.
	Fuel level in carbureator float chamber improper?	Adjust carbureator float
	Carbon deposits in cylinder?	Clean or replace cylinder
Not enough power available (compression normal, miss-firing).	Ignition coil defective?	Flush fuel sytem and replace with fresh fuel.
	Ignition plug often shorts?	Replace ignition wires, clean ignition.
	Fuel in use inadequate (water, dust)?	Flush fuel sytem and replace with fresh fuel.
Engine overheats.	Excessive carbon deposition in combustion chamber?	Clean or replace crankcase.
	Exhaust or muffler clogged with carbon.	Clean or replace muffler.
	Spark plug heat value incorrect?	Replace spark plug with correct type spark plug.

MC-44S CONCRETE MIXER — TROUBLESHOOTING (ENGINE/MIXER)

TABLE 9. ENGINE TROUBLESHOOTING (Continued)

SYMPTOM	POSSIBLE PROBLEM	SOLUTION
Operation not satisfactory		
Rotational speed fluctuates.	Governor adjustment improper?	Adjust governor to correct lever.
	Governor spring defective?	Clean or replace ignition.
	Fuel flow erratic?	Check fuel line.
	Air taken in through suction line?	Check suction line.
Recoil starter not working properly.	Dust in rotating part?	Clean recoil starter assembly.
	Spring spring failure?	Replace sprial spring.

TABLE 10. MIXER TROUBLESHOOTING

SYMPTOM	POSSIBLE PROBLEM	SOLUTION
Drum rotates rough.	Defective ring gear?	Check that the ring gear and bearings are not worn . Replace as necessary.
	Defective pinion gear?	Check that the pinion gear and bearings are not worn . Replace as necessary.
	Worn V-belt?	Replace V-belt.
	Loose pulley?	Tighten or replace pulley.
Drum does not rotate at all.	Incorrect or no voltage being supplied to electric motor?	Check that the electric motor has the correct supply voltage.
	Power to electric motor?	Inspect power source and extension cord. Push reset button on electric motor. Make sure correct voltage is being supplied to motor.
	Fuel?	Check level of fuel in fuel tank. Add fuel if necessary. Make sure fuel is being supplied to the engine. Check to ensure that the fuel filter is not clogged.
	Broken V-belt?	Replace V-belt.
	Defective ring or pinion gears?	Check that the gears and bearings are not broken. Replace as necessary.
	Defective electric motor?	Replace electric motor.

EXPLANATION OF CODE IN REMARKS COLUMN

The following section explains the different symbols and remarks used in the Parts section of this manual. Use the help numbers found on the back page of the manual if there are any questions.

NOTICE

The contents and part numbers listed in the parts section are subject to change **without notice**. Multiquip does not guarantee the availability of the parts listed.

SAMPLE PARTS LIST

NO.	PART NO.	PART NAME	QTY.	REMARKS
1	12345	BOLT.....	1	INCLUDES ITEMS W/%
2%		WASHER, 1/4 IN.....		NOT SOLD SEPARATELY
2%	12347	WASHER, 3/8 IN....	1	MQ-45T ONLY
3	12348	HOSE	A/R	MAKE LOCALLY
4	12349	BEARING	1	S/N 2345B AND ABOVE

NO. Column

Unique Symbols — All items with same unique symbol

(@, #, +, %, or >) in the number column belong to the same assembly or kit, which is indicated by a note in the “Remarks” column.

Duplicate Item Numbers — Duplicate numbers indicate multiple part numbers, which are in effect for the same general item, such as different size saw blade guards in use or a part that has been updated on newer versions of the same machine.

NOTICE

When ordering a part that has more than one item number listed, check the remarks column for help in determining the proper part to order.

PART NO. Column

Numbers Used — Part numbers can be indicated by a number, a blank entry, or TBD.

TBD (To Be Determined) is generally used to show a part that has not been assigned a formal part number at the time of publication.

A blank entry generally indicates that the item is not sold separately or is not sold by Multiquip. Other entries will be clarified in the “Remarks” Column.

QTY. Column

Numbers Used — Item quantity can be indicated by a number, a blank entry, or A/R.

A/R (As Required) is generally used for hoses or other parts that are sold in bulk and cut to length.

A blank entry generally indicates that the item is not sold separately. Other entries will be clarified in the “Remarks” Column.

REMARKS Column

Some of the most common notes found in the “Remarks” Column are listed below. Other additional notes needed to describe the item can also be shown.

Assembly/Kit — All items on the parts list with the same unique symbol will be included when this item is purchased.

Indicated by:

“INCLUDES ITEMS W/(unique symbol)”

Serial Number Break — Used to list an effective serial number range where a particular part is used.

Indicated by:

“S/N XXXXX AND BELOW”

“S/N XXXX AND ABOVE”

“S/N XXXX TO S/N XXX”

Specific Model Number Use — Indicates that the part is used only with the specific model number or model number variant listed. It can also be used to show a part is NOT used on a specific model or model number variant.

Indicated by:

“XXXXX ONLY”

“NOT USED ON XXXX”

“Make/Obtain Locally” — Indicates that the part can be purchased at any hardware shop or made out of available items. Examples include battery cables, shims, and certain washers and nuts.

“Not Sold Separately” — Indicates that an item cannot be purchased as a separate item and is either part of an assembly/kit that can be purchased, or is not available for sale through Multiquip.

MC-44S CONCRETE MIXER — SUGGESTED SPARE PARTS

MC-44S CONCRETE MIXER 1 TO 4 UNITS WITH HONDA GX120K1QX2 ENGINE

<u>Qty.</u>	<u>P/N</u>	<u>Description</u>
2	507725	V-BELT w/GAS ENGINE
1	29173-001	STOP BUTTON w/GAS ENGINE
2	491010	LATCH SET
1	500904	EXPANSION PLUG
2	EM903017	SPINDLE BEARING CUP
2	EM903054	SPINDLE BEARING CONES
1	EM505472	SPACER, DRUM
2	041006204	BEARING, JACKSHAFT
2	EM914288	SEAL, AXLE
2	EM903012	BEARING CUP
2	EM903113	BEARING CONE
2	3469	DUST CAP, AXLE
4	17210ZE0505	ELEMENT, AIR CLEANER
4	9807955846	SPARK PLUG
1	17620ZH7023	CAP, FUEL TANK
1	28462ZH8003	ROPE, RECOIL STARTER

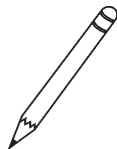
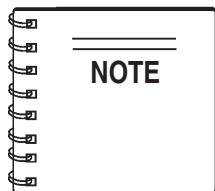

Part numbers on this Suggested Spare Parts List may supercede/replace the P/N's shown in the test pages of this manual.

MC-44S CONCRETE MIXER — NAME PLATE AND DECALS

NAME PLATE AND DECALS

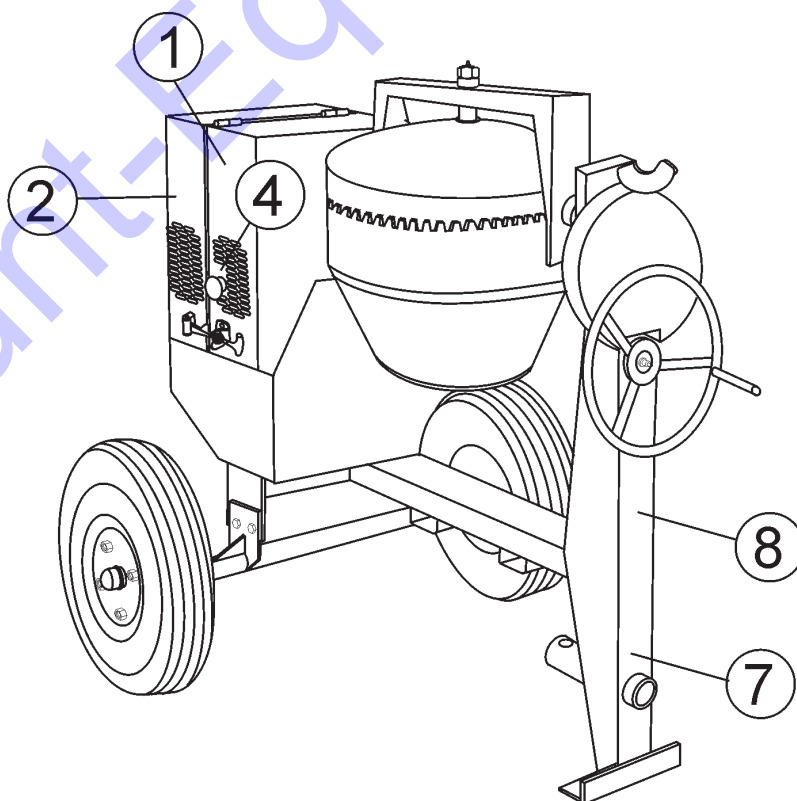
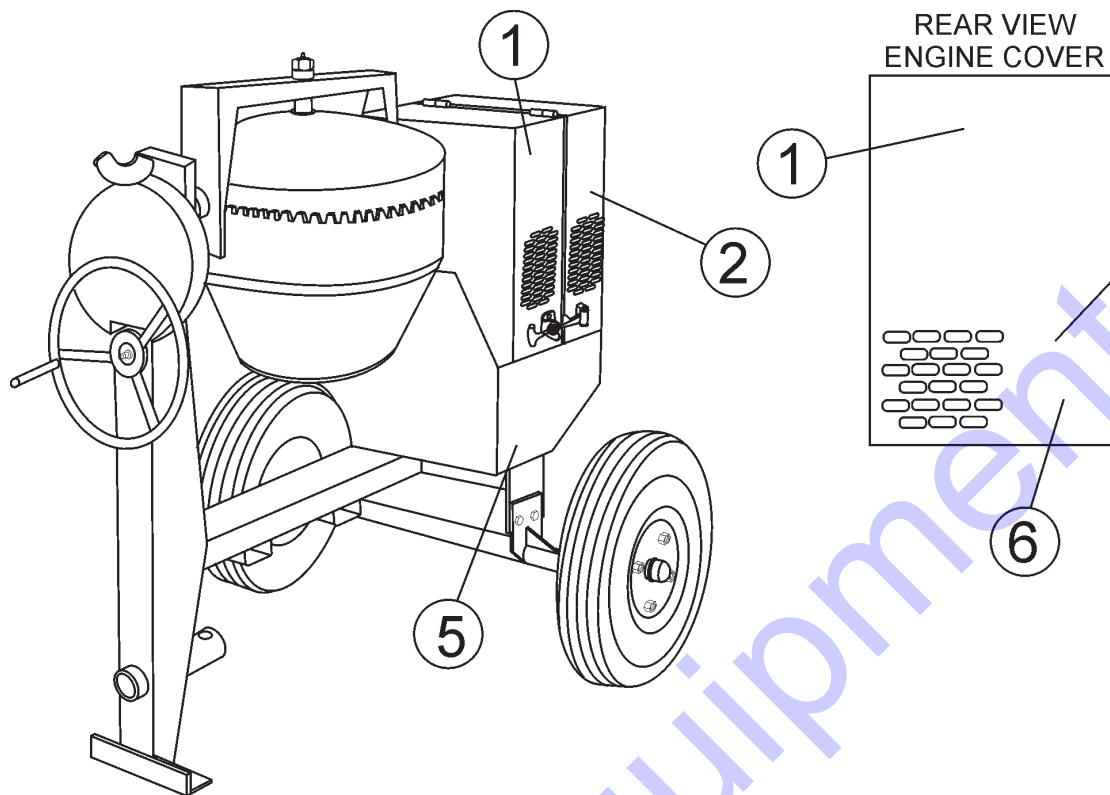

MC-44S CONCRETE MIXER— NAME PLATE AND DECALS

NAME PLATE AND DECALS

<u>NO</u>	<u>PART NO</u>	<u>PART NAME</u>	<u>QTY.</u>	<u>REMARKS</u>
1	512910	MQ MULTIQUIP LOGO	3	
2	CIPDCL160	DECAL, CRUSH WARNING	2	
3	504713	DECAL, SAFETY INSTRUCTIONS	1	
4	EM948630	DECAL, EMERGENCY STOP	1	
5	DCL151	DECAL, TOWING INSTRUCTIONS	1	
6	35137	DECAL, READ	1	
7	13118	DECAL, POWDER COATED	1	
8		NAMEPLATE	1 CONTACT MQ PARTS DEPT.

SEE OPERATION AND SAFETY DECALS PAGE.

MC-44S — STEEL BARREL ASSY.

STEEL BARREL ASSY.

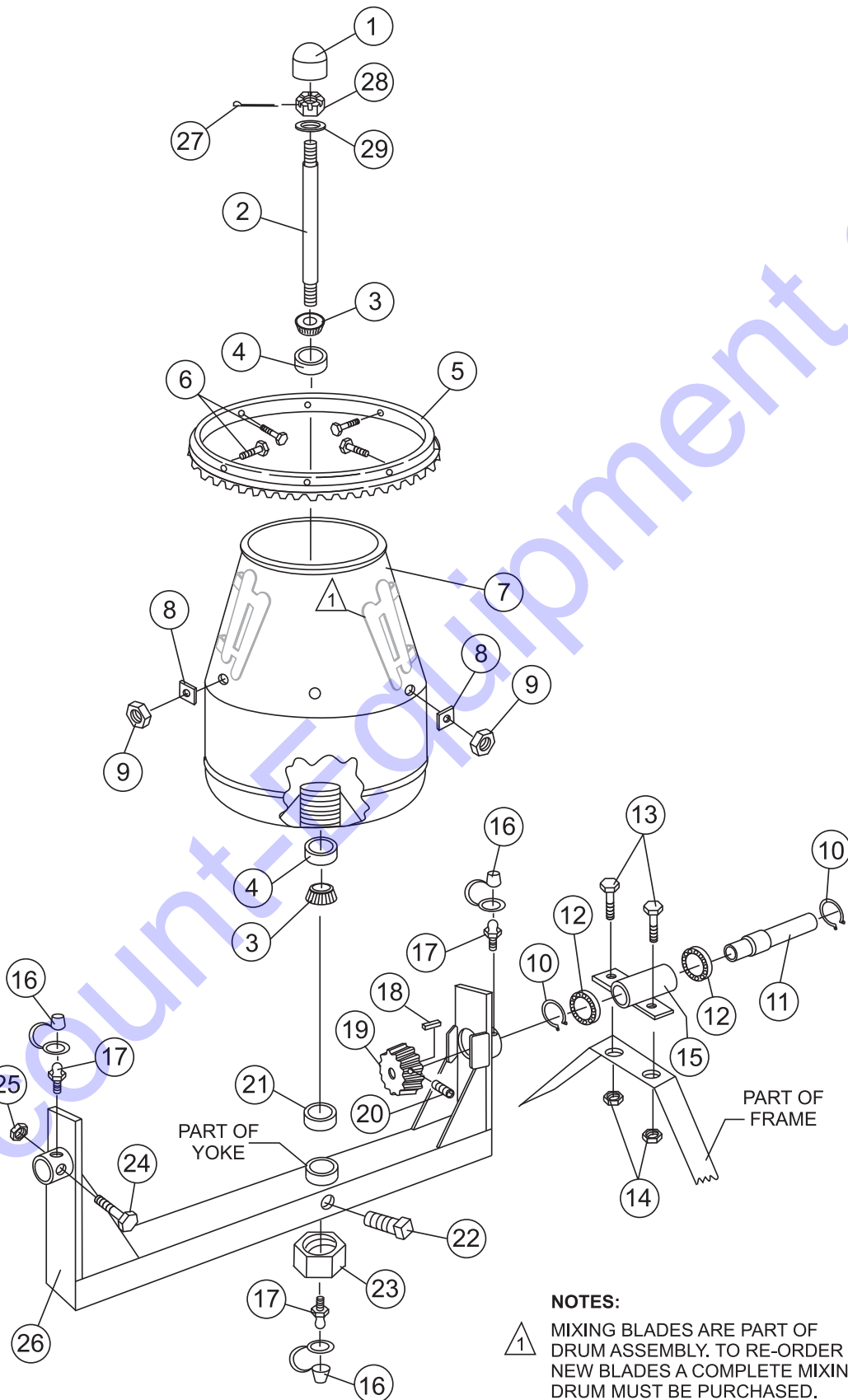

MC-44S — STEEL BARREL ASSY.

STEEL BARREL ASSY.

<u>NO</u>	<u>PART NO</u>	<u>PART NAME</u>	<u>QTY.</u>	<u>REMARK</u>
1	500904	CAP	1	
2	501867	KING PIN	1	
3	EM903054	SPINDLE BEARING 5/8" CONE	2	REPLACES 492154
4	EM903017	SPINDLE BEARING CUP	2	REPLACES 492233
5	504096	RING GEAR	1	
6	EM963610	BOLT 3/8" NC 1-1/4" G5	6	
7	501061	BARREL, STEEL 4 CU. FT.	1	
8	511732	SHIM 0.25 THICK	AR	
8	511731	SHIM .187 THICK	AR	
8	511730	SHIM .140 THICK	AR	
9	EM969013	NUT, LOCK 3/8" NC	5	
10	490952	RING, RETENTION	2	
11	502019	DRIVE PINION SHAFT	1	
12	493296	PINION SHAFT BEARING	2	
13	EM963692	BOLT 1/2" NC X 1-1/2" G5	2	
14	492584	LOCKNUT, HEX 1/2" NC	2	
15	514672	HOUSING JACKSHAFT	1	
16	491008	CAP, GREASE FITTING	3	
17	EM916001	GREASE FITTING 1/8" NPT	3	REPLACES 491698
18	500214	SQUARE KEY 1/4" X 30 MM	1	
19	501917	DRIVE PINION	1	
20	492467	ALLEN SCREW 5/16 NC 3/8"	1	
21	EM505472	SPACER, BARREL	1	
22	492483	SET SCREW 3/8" X 1- 1/4" NC	1	
23	500601	NUT, HEX LOWER 1"	1	REPLACES 492579
24	492406	BOLT 5/8" NC X 1-1/2" NC	2	
25	492584	LOCKNUT, HEX 1/2" NC	2	
26	510736	YOKE	1	
27	491685	COTTER PIN 3/32" X 2"	1	
28	500601	CASTLE NUT 1"	1	
29	501269	SPACER	1	

MC-44S — MAIN FRAME ASSY.

MAIN FRAME ASSY.

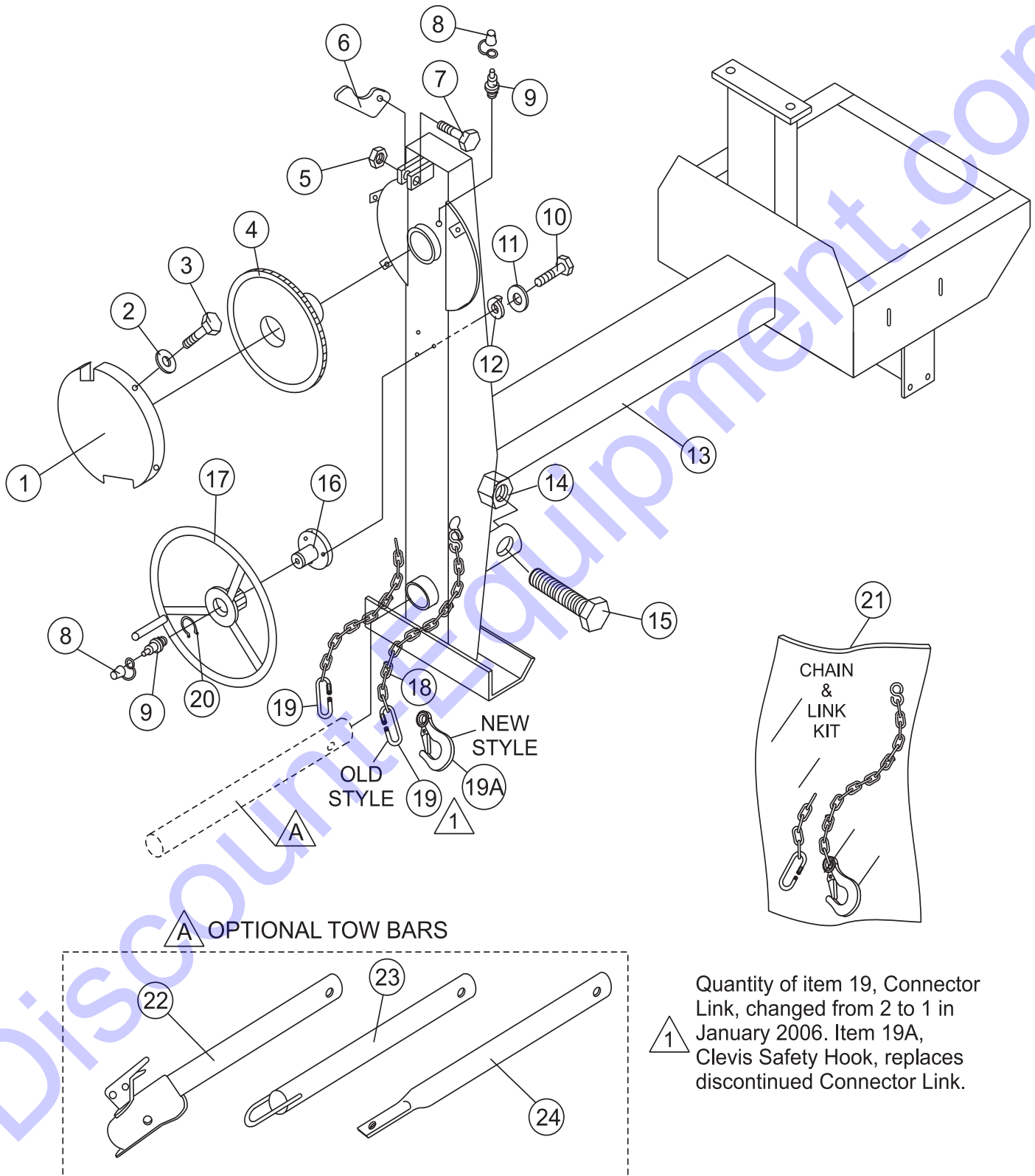

Quantity of item 19, Connector Link, changed from 2 to 1 in January 2006. Item 19A, Clevis Safety Hook, replaces discontinued Connector Link.

MC-44S — MAIN FRAME ASSY.

MAIN FRAME ASSY.

<u>NO</u>	<u>PART NO</u>	<u>PART NAME</u>	<u>QTY.</u>	<u>REMARK</u>
1	501844	GUARD, GEAR WHEEL	1	
2	2101402	WASHER, LOCK 1/4"	4	
3	492284	ROUND HEAD BOLT 1/4" NC 3/8 G2"	4	REPLACES 492279
4	502017	DUMP GEAR	1	
5	EM969013	NUT, LOCK 3/8" NC	1	
6	490896	DUMP LATCH	1	
7	EM963610	BOLT 3/8" NC X 1-1/2" G5	1	
8	491008	GREASE CAP	2	
9	EM916001	GREASE FITTING 1/8" NPT	2	REPLACES 491698
10	EM963055	ALLEN BOLT 3/16" NS X 5/8"	4	
11	3103160	WASHER, LOCK 3/16"	4	
12	495595	WASHER, FLAT 3/16"	4	
13	514643	FRAME	1	
14	10176	LOCK NUT 1/2 NC	1	REPLACES 492586
15	EM124	BOLT 1/2"- 13 X 4 G5	1	
16	500596	HANDWHEEL SHAFT	1	
17	501902	HANDWHEEL	1	
18*		SAFETY CHAIN	1	
19*	01004	CONNECTOR LINK	2	BEFORE JANUARY 2006
19*	01004	CONNECTOR LINK	1	AFTER JANUARY 2006
19A*	516580	CLEVIS SAFETY HOOK, 1/4"	1	AFTER JANUARY 2006
20	490958	RING RETAINING	1	
21	13363KIT	CHAIN LINK KIT	1	INCLUDES ITEMS W/*
22	HBC-1	BALL HITCH 2-INCH	1	CONTACT UNIT SALES
23	HLC-1	LOOP HITCH	1	CONTACT UNIT SALES
24	HPC-1	PIN HITCH 1-INCH	1	CONTACT UNIT SALES

AXLE ASSY.

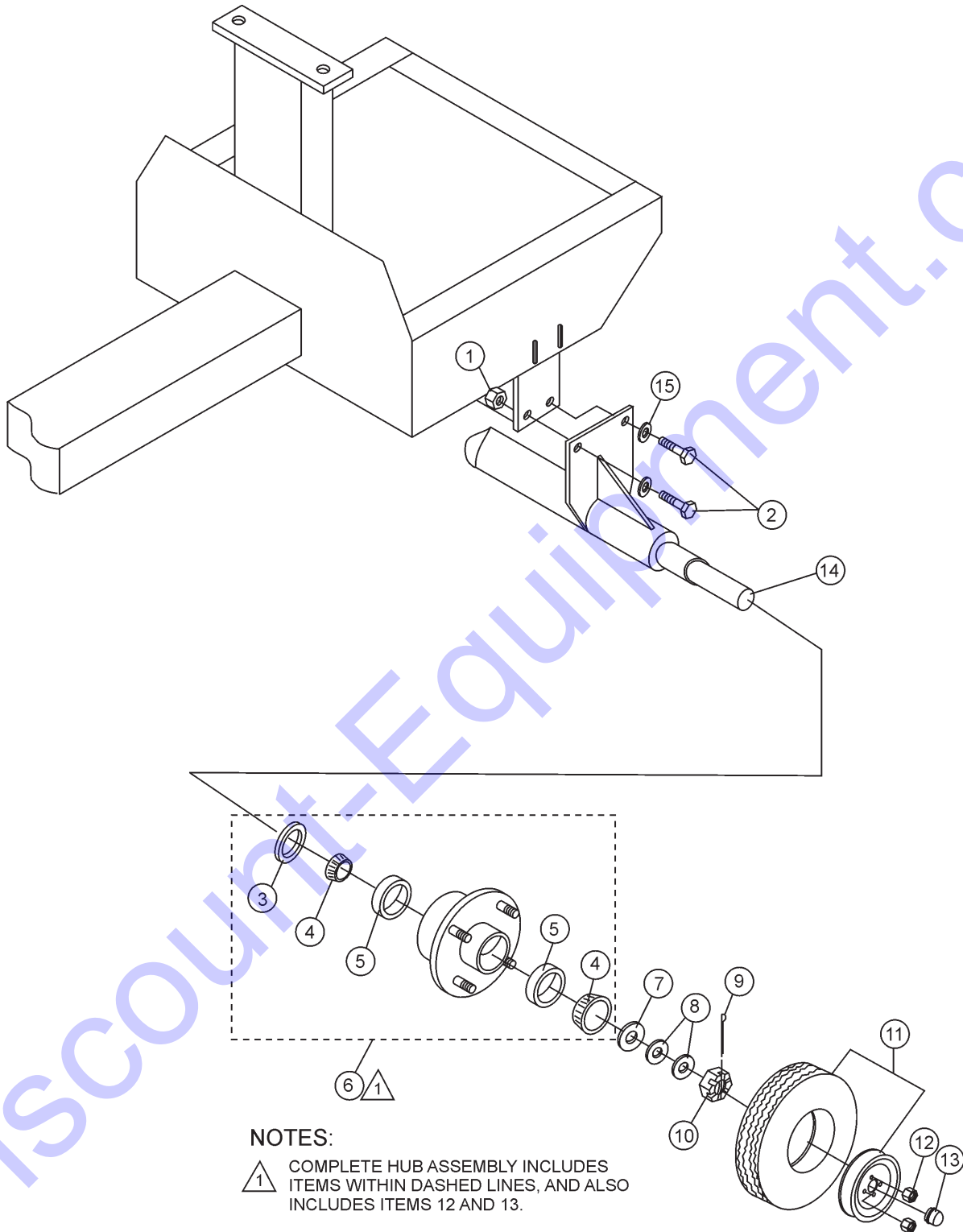

AXLE ASSY.

<u>NO</u>	<u>PART NO</u>	<u>PART NAME</u>	<u>QTY.</u>	<u>REMARK</u>
1	492584	LOCK NUT 1/2" NC	8	
2	492394	BOLT 1/2" NC 1-1/2" G5	8	
3*#	EM914288	OIL SEAL	2	
4#	EM903113	BEARING CONE	4	
5#	EM903012	BEARING CUP	4	
6	EM941306	HUB ASSY., 4-BOLT (1-1/16" SPINDLE)	2	INCLUDES ITEMS W/#
7	EM511159	WASHER, FLAT, .087" THICKNESS	2	
8	EM501299	WASHER, FLAT, .135" THICKNESS	AR	
9	491688	COTTER PIN 1/8" X 1-1/2'	2	
10	8164	NUT, SLOTTED HEX JAM 1"- 20	2	
11	3005	TIRE AND RIM, CARLISE	2	BEFORE JANUARY 2006
11	516476	TIRE AND RIME, TOWMASTER II	2	AFTER JANUARY 2006
12#	8115	LUG NUTS	8	
13#	3469	DUST CAP	2	
14	514679	AXLE, RIGID	1	
15	492600	WASHER, FLAT	12	

MC-44S — CABINET ASSY.

CABINET ASSY.

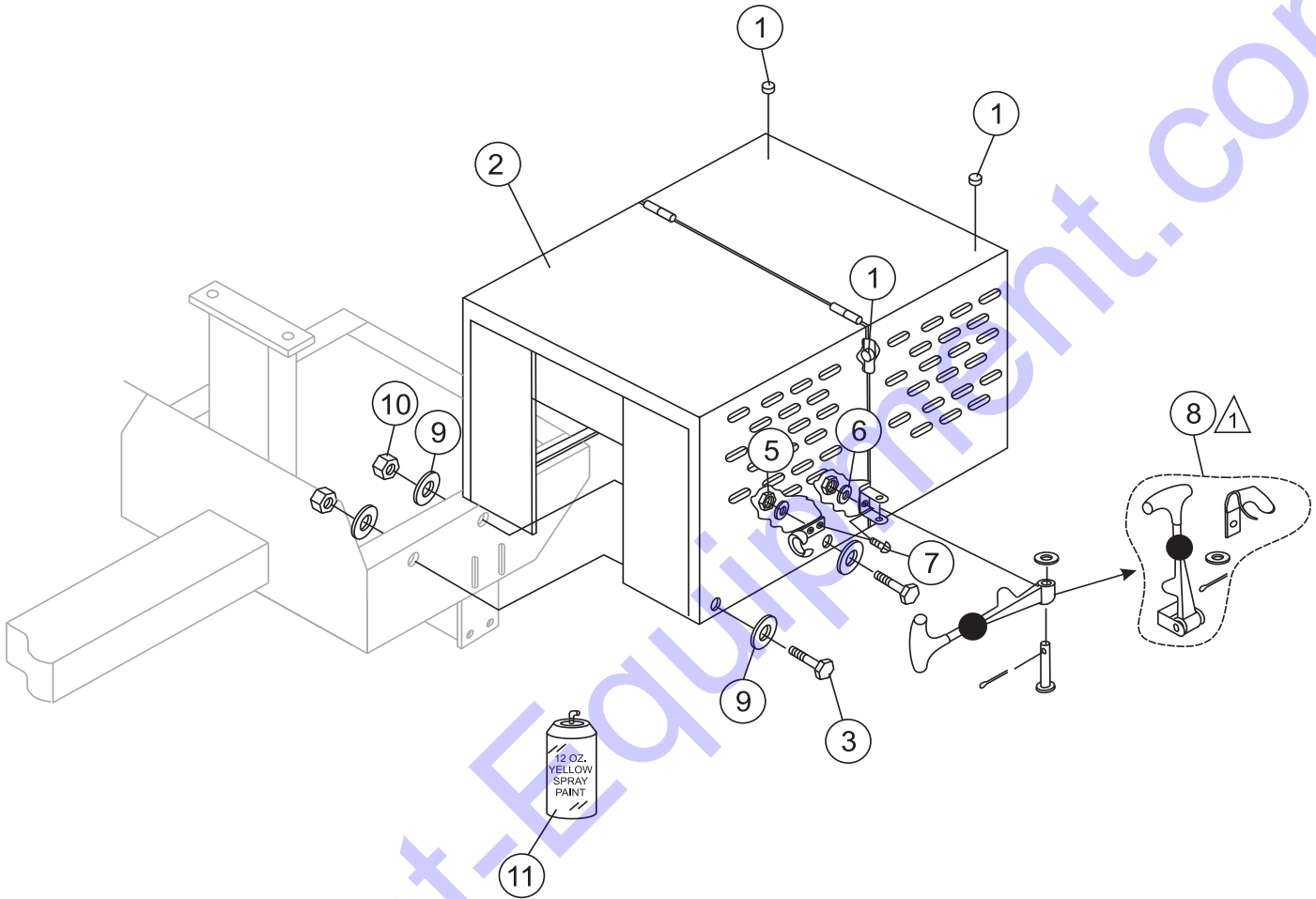

NOTES:

- △ COMPLETE LATCH ASSEMBLY INCLUDES ITEMS WITHIN DASHED LINES. ITEMS CANNOT BE PURCHASED SEPARATELY.

CABINET ASSY.

<u>NO</u>	<u>PART NO</u>	<u>PART NAME</u>	<u>QTY.</u>	<u>REMARKS</u>
1	490202	RUBBER PROTECTOR	4	
2	514771	ENGINE HOUSING CABINET W/DECALS	1	INCLUDES ITEM W//* REPLACES P/N 514648
3	492375	BOLT 3/8" NC X 1" G5	6	
4	EM923023	WASHER, FLAT 5/16"	8	
5	13287	LOCK NUT 8-32	6	REPLACEMENT PART ONLY
6	2203	WASHER, FLAT #10	6	REPLACEMENT PART ONLY
7	1307	RHMS 8-32 X 1/2"	6	REPLACEMENT PART ONLY
8/*	491010	LATCH ASSY., COMPLETE	2	
9	492598	WASHER, FLAT 3/8"	12	
10	2105164	NUT 3/8" NC G5	6	
11	EM974007	PAINT, SPRAY CAN 12 OZ. TRAFFIC RED	AR	

MC-44S — GAS ENGINE MOUNTING PLATE ASSY.

GAS ENGINE MOUNTING PLATE ASSY.

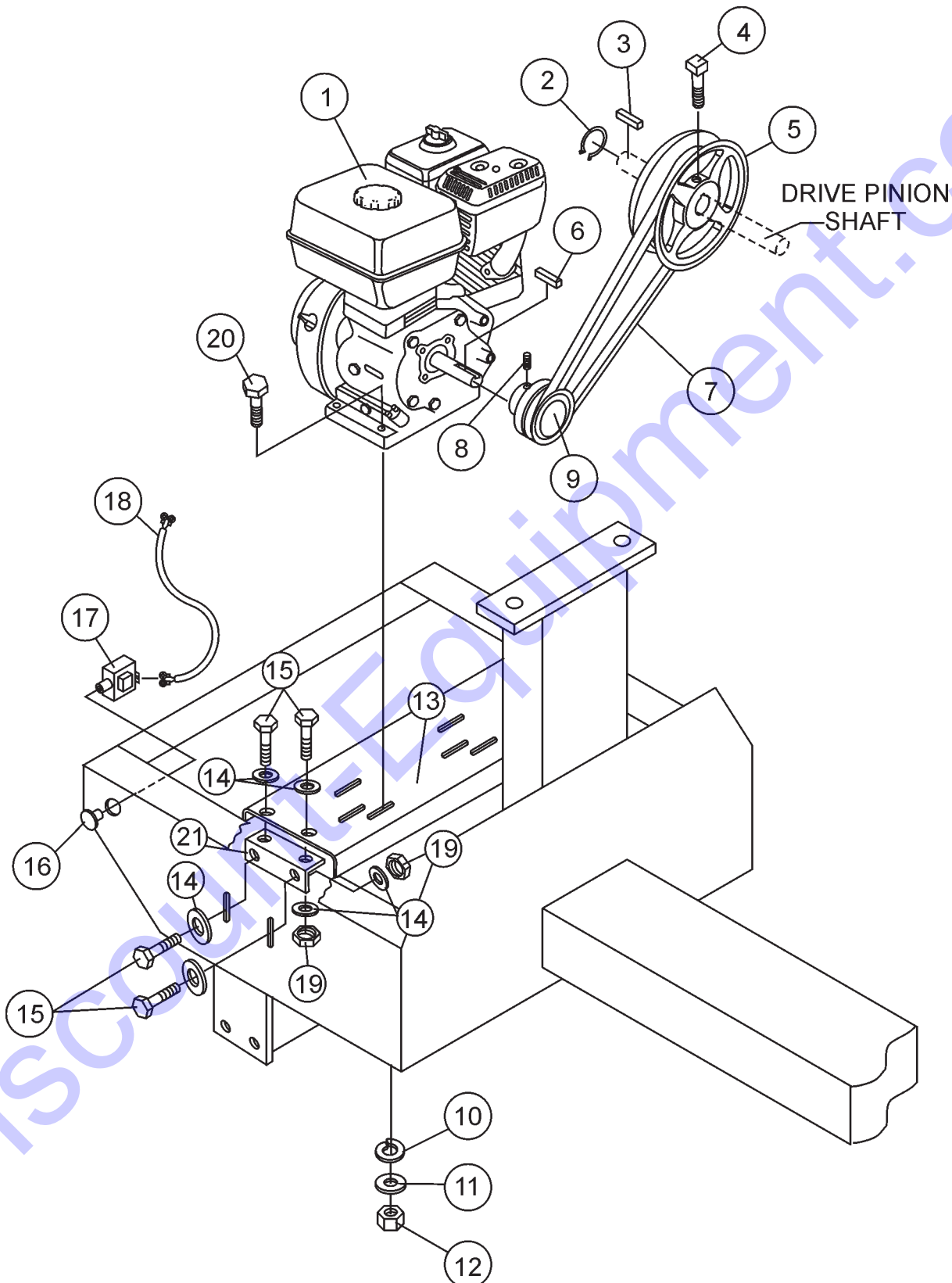

MC-44S — GAS ENGINE MOUNTING PLATE ASSY.

GAS ENGINE MOUNTING PLATE ASSY.

<u>NO</u>	<u>PART NO</u>	<u>PART NAME</u>	<u>QTY.</u>	<u>REMARKS</u>
1	GX120K1QX2	ENGINE, HONDA 3.9 HP	1	
2	490956	RING, RETAINING	1	
3	500246	SQUARE KEY 1/4 X 35 MM	1	
4	EM961045	SET SCREW 5/16" NC X 3/4"	1	
5	492066	UPPER PULLEY	1	
6	501019	SQUARE KEY 3/16" X 45 MM	1	
7	507725	V-BELT A-48	1	USED UP TO JUNE 2005
7	EM507846	V-BELT A-50	1	USED STARTING JULY 2005
8	492467	ALLEN SCREW 5/16" NC X 3/8"	1	
9	492065	DRIVE PULLEY 4.0 HP	1	
10	EM923343	WASHER, LOCK 5/16"	4	
11	EM923023	WASHER, FLAT 5/16"	4	
12	2105164	NUT, HEX 5/16 X18 NC G5	4	
13	514670	BASE PLATE, ENGINE	1	
14	492600	WASHER, FLAT 1/2"	8	
15	EM963692	BOLT, HEX 1/2" NC 1-1/2" G5	4	
16	29174-001	BUTTON, STOP	1	
17	29173-001	SWITCH, STOP	1	
18	510573C	ENGINE CABLE HARNESS	1	
19	492584	LOCKNUT 1/2"	4	
20	492367	BOLT 5/16" X 1-3/4" G5	4	
21	514684	SUPPORT BRACKET	1	

MC-44S — ELECTRIC MOTOR MOUNTING PLATE ASSY.

ELECTRIC MOTOR MOUNTING PLATE ASSY.

<u>NO</u>	<u>PART NO</u>	<u>PART NAME</u>	<u>QTY.</u>	<u>REMARKS</u>
1	34F3245596	MOTOR, ELECTRIC .5 HP	1	
2	490956	RING, RETAINING	1	
3	500246	SQUARE KEY 3/16" X 45 MM	1	
4	EM961045	SET SCREW 5/16" NC X 3/4"	1	
5	492066	UPPER PULLEY	1	
6	501019	SQUARE KEY 3/16" X 45 MM	1	
7	507725	V-BELT A-48	1	USED UP TO JUNE 2005
7	EM507846	V-BELT A-50	1	USED STARTING JULY 2005
8	492467	ALLEN SCREW 5/16" NC X 1/2"	1	
9	492067	DRIVE PULLEY	1	
10	EM923343	WASHER, LOCK 5/16"	4	
11	EM923023	WASHER, FLAT 5/16"	4	
12	492553	NUT, HEX 5/16 X18 NC G5	4	
13	502041	BASE PLATE ENGINE	1	
14	492600	WASHER, FLAT 1/2"	8	
15	EM963692	BOLT, HEX 1/2" NC 1-1/2" G5	4	
16	4922584	LOCKNUT 1/2"	4	
17	492367	BOLT 5/16" X 1-3/4"	4	
18	514684	SUPPORT BRACKET	1	

HONDA GX120K1QX2 ENGINE — AIR CLEANER ASSY.

AIR CLEANER ASSY.

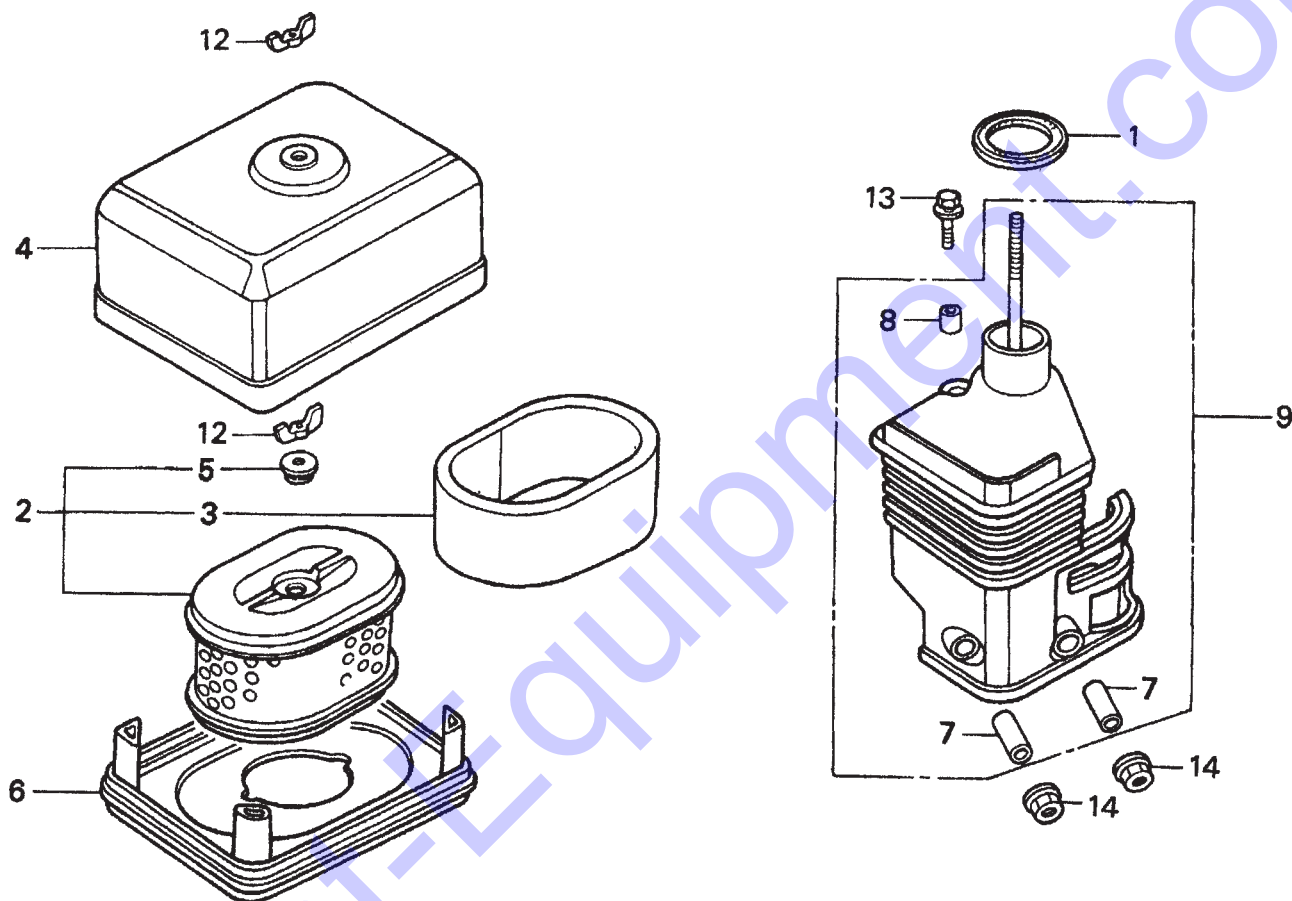

HONDA GX120K1QX2 ENGINE — AIR CLEANER ASSY.

AIR CLEANER ASSY.

<u>NO.</u>	<u>PART NO.</u>	<u>PART NAME</u>	<u>QTY.</u>	<u>REMARKS</u>
1	16271ZE1000	GASKET, ELBOW	1	
2	17210ZE0505	ELEMENT, AIR CLEANER (DUAL)	1	INCLUDES ITEMS W/*
3*	17218ZE0505	FILTER, OUTER	1	
4	17230ZE0820	COVER, AIR CLEANER (DUAL)	1	
5*	17232891000	GROMMET, AIR CLEANER	1	
7#	17238ZE0010	COLLAR, AIR CLEANER	2	
8#	17239ZE1000	COLLAR B, AIR CLEANER	1	
9	17410ZE0030	ELBOW, AIR CLEANER	1	INCLUDES ITEMS W/#
12	90325044000	WINGNUT, TOOL BOX SETTING	2	
13	957010602000	BOLT, FLANGE 6X20	1	
14	9405006000	NUT, FLANGE 6MM	2	

HONDA GX120K1QX2 ENGINE — CAMSHAFT ASSY.

CAMSHAFT ASSY.

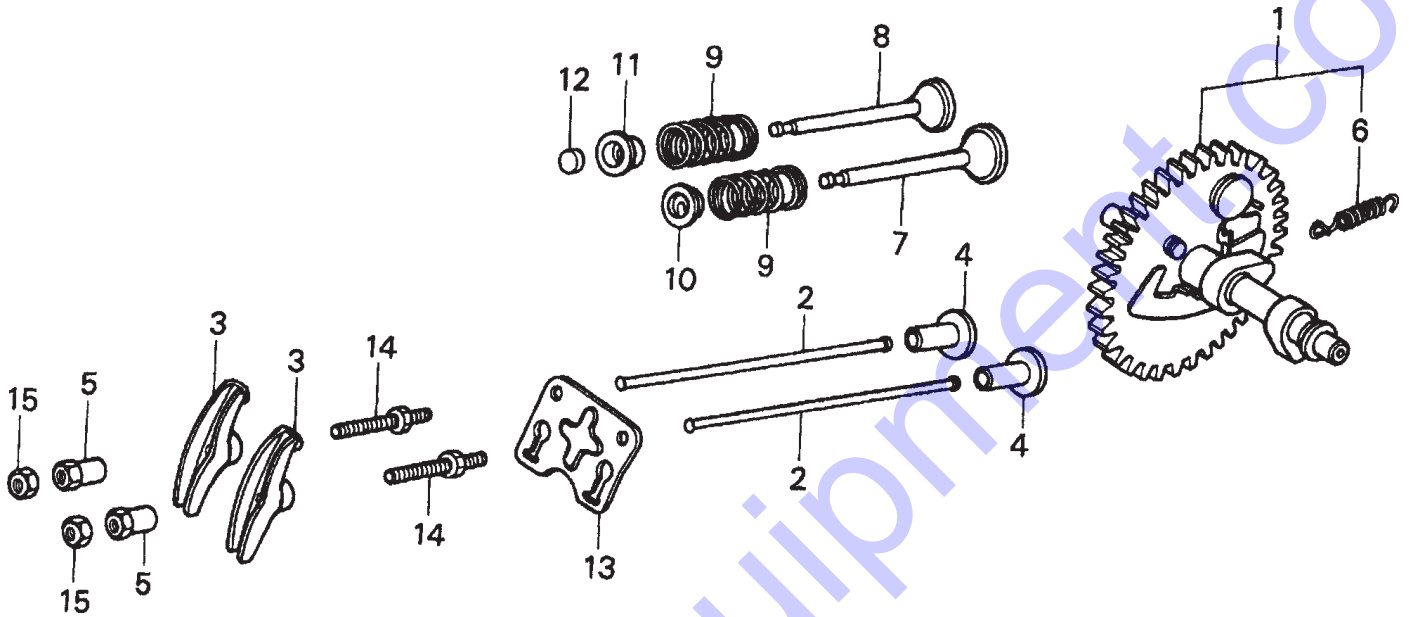

HONDA GX120K1QX2 ENGINE — CAMSHAFT ASSY.

CAMSHAFT ASSY.

<u>NO.</u>	<u>PART NO.</u>	<u>PART NAME</u>	<u>QTY.</u>	<u>REMARKS</u>
1	14100ZE0812	CAMSHAFT ASSEMBLY	1	INCLUDES ITEMS W/*
2	14410ZE0010	ROD, PUSH	2	
3	14431ZE1000	ARM, VALVE ROCKER	2	
4	14441ZE1010	LIFTER, VALVE	2	
5	14451ZE1013	PIVOT, ROCKER ARM	2	
6*	14568ZE1000	SPRING, WEIGHT RETURN	1	
7	14711ZF0010	VALVE, IN.	1	
8	14721ZF0000	VALVE, EX.	1	
9	14751ZF1000	SPRING, VALVE	2	
10	14771ZE1000	RETAINER, IN. VALVE SPRING	1	
11	14773ZE1000	RETAINER, EX. VALVE SPRING	1	
12	14781ZE1000	ROTATOR, VALVE	1	
13	14791ZE0010	PLATE, PUSH ROD GUIDE	1	
14	90012ZE0010	BOLT, PIVOT 8MM	2	
15	90206ZE1000	NUT, PIVOT ADJ.	2	

HONDA GX120K1QX2 ENGINE — CARBURETOR ASSY.

CARBURETOR ASSY.

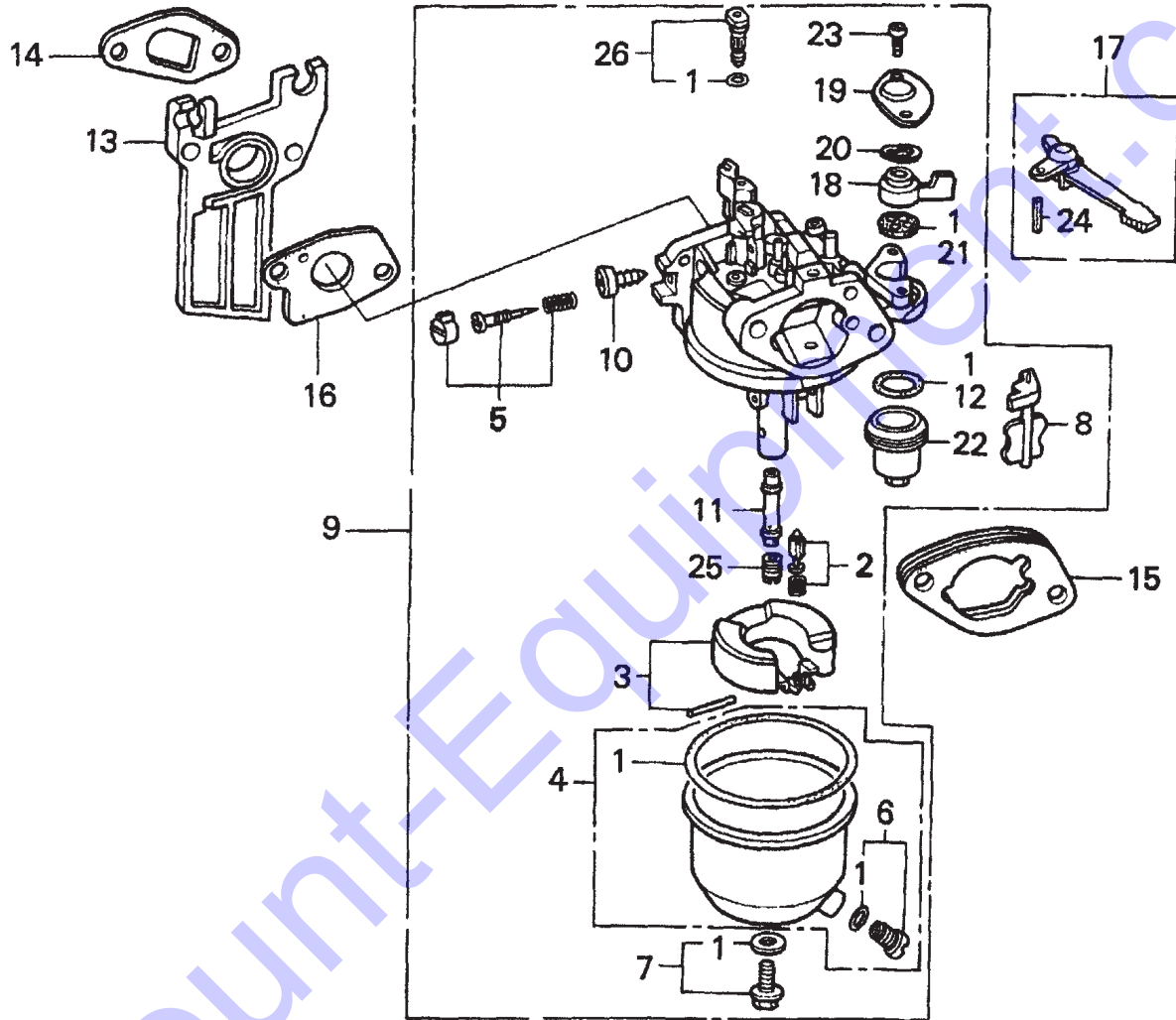

HONDA GX120K1QX2 ENGINE — CARBURETOR ASSY.

CARBURETOR ASSY.

<u>NO.</u>	<u>PART NO.</u>	<u>PART NAME</u>	<u>QTY.</u>	<u>REMARKS</u>
1*	16010ZE1812	GASKET SET	1	
2*	16011ZE0005	VALVE SET, FLOAT	1	
3*	16013ZE0005	FLOAT SET	1	
4*	16015ZE1811	CHAMBER SET, FLOAT	1	
5*	16016ZH7W01	SCREW SET	1	
6*	16024ZE1811	SCREW SET, DRAIN	1	
7*	16028ZE0005	SCREW SET B	1	
8*	16044ZE0005	CHOKE SET	1	
9	16100ZH7W51	CARBURETOR ASSEMBLY, BE60B B	1	INCLUDES ITEMS W/*
10*	16124ZE0005	SCREW, THROTTLE STOP	1	
11*	16166ZH7W50	NOZZLE, MAIN	1	
12*	16173001004	GASKET, FUEL STRAINER CUP	1	
13	16211ZE0000	INSULATOR, CARBURETOR	1	
14	16212ZH7800	GASKET, INSULATOR	1	
15	16220ZE1020	SPACER, CARBURETOR	1	
16	16221ZH8801	GASKET, CARBURETOR	1	
17	16610ZE1000	LEVER, CHOKE (STANDARD)	1	INCLUDES ITEMS W/#
18*	16953ZE1812	LEVER, VALVE	1	
19*	16954ZE1811	PLATE, LEVER SETTING	1	
20*	16956ZE1811	SPRING, VALVE LEVER	1	
21*	16957ZE1812	GASKET, VALVE	1	
22*	16967ZE0811	CUP, FUEL STRAINER	1	
23*	93500030080G	SCREW, PAN (3 X 6)	2	
24#	9430520122	PIN, SPRING (2 X 12)	1	
25	99101ZH80550	JET, MAIN (#55) (OPTIONAL)	1	
25	99101ZH80580	JET, MAIN (#58) (OPTIONAL)	1	
25*	99101ZH80600	JET, MAIN (#60)	1	
26*	99204ZE00350	JET, SET, PILOT (#35)	1	

HONDA GX120K1QX2 ENGINE — CONTROL ASSY.

CONTROL ASSY.

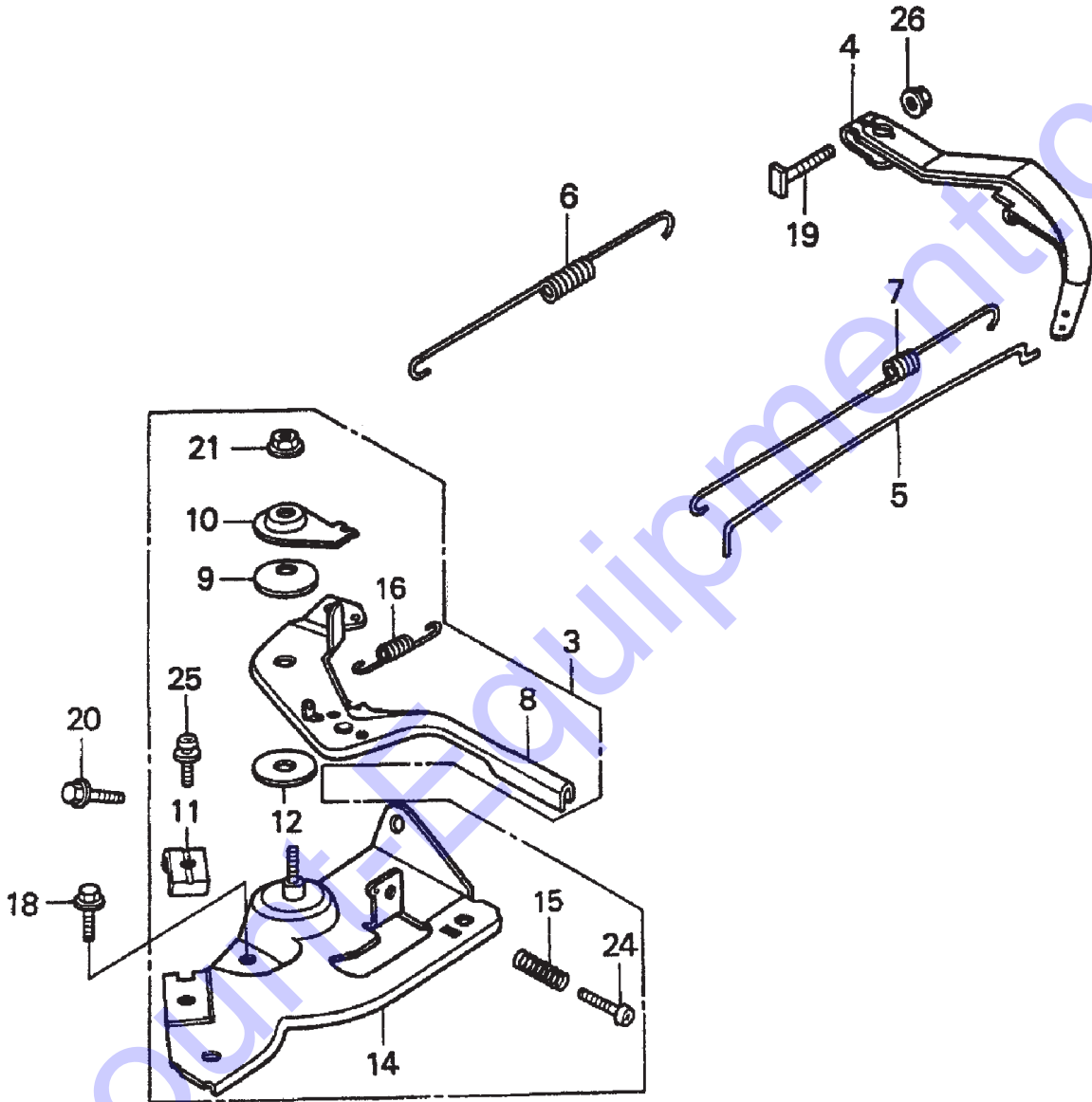

HONDA GX120K1QX2 ENGINE — CONTROL ASSY.

CONTROL ASSY.

<u>NO.</u>	<u>PART NO.</u>	<u>PART NAME</u>	<u>QTY.</u>	<u>REMARKS</u>
3	16500ZH7820	CONTROL ASSEMBLY (REMOTE)	1	INCLUDES ITEMS W/#
4	16551ZE0010	ARM, GOVERNOR	1	
5	16555ZE0000	ROD, GOVERNOR	1	
6	16561ZE0020	SPRING, GOVERNOR	1	
7	16562ZE0020	SPRING, THROTTLE RETURN	1	
8#	16571ZH7000	LEVER, CONTROL	1	
9#	16574ZE1000	SPRING, LEVER	1	
10#	16575ZH8000	WASHER, CONTROL LEVER	1	
11#	16576891000	HOLDER, CABLE		
12#	16578ZE1000	SPACER, CONTROL LEVER	1	
14#	16580ZH7810	BASE CONTROL	1	
15#	16584883300	SPRING, CONTROL ADJUSTING	1	
16#	16592ZE1810	SPRING, CABLE RETURN		
18	90013883000	BOLT, FLANGE 6X12 (CT200)	1	
19	90015ZE5010	BOLT, GOVERNOR ARM	1	
20	90022888010	BOLT, FLANGE 6X20 (CT200)	1	
21#	90114SA0000	NUT, SELF- LOCK 6MM	1	
24#	93500050250H	SCREW, PAN 5X25	1	
25#	93500050160A	SCREW, PAN	1	
26	9405006000	NUT, FLANGE 6MM	1	

HONDA GX120K1QX2 ENGINE — CRANKCASE COVER ASSY.

CRANKCASE COVER ASSY.

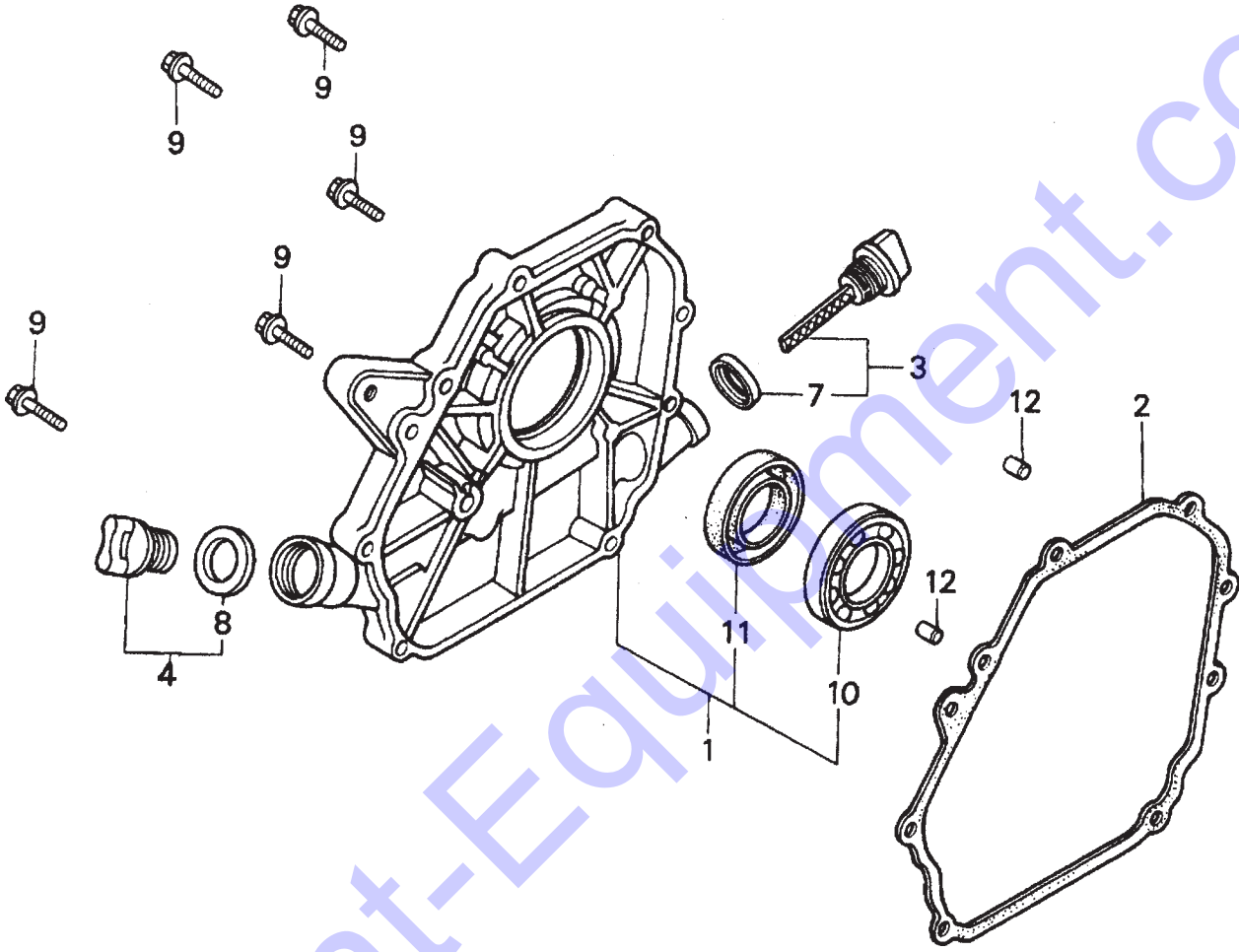

HONDA GX120K1QX2 ENGINE — CRANKCASE COVER ASSY.

CRANKCASE COVER ASSY.

<u>NO.</u>	<u>PART NO.</u>	<u>PART NAME</u>	<u>QTY.</u>	<u>REMARKS</u>
1	11300ZE0640	COVER ASSEMBLY, CRANKCASE (W- TYPE).....	1	INCLUDES ITEMS W/*
2	11381ZH7800	GASKET, CASE COVER	1	
3	15600ZE1003	CAP ASSEMBLY, OIL FILLER	1	INCLUDES ITEMS W/#
4	15600ZG4003	CAP ASSEMBLY, OIL FILLER	1	INCLUDES ITEMS W/+
7#	15625ZE1003	GASKET, OIL FILLER CAP	1	
8+	15625ZE1003	GASKET, OIL FILLER CAP	1	
9	90015883000	BOLT, FLANGE 6X28	7	
10*	91001878003	BEARING, RADIAL BALL	1	
11*	91203ZE0003	OIL SEAL 22X41X6	1	
12	9430108140	PIN A, DOWEL 8X14	2	

HONDA GX120K1QX2 ENGINE — CRANKSHAFT ASSY.

CRANKSHAFT ASSY.

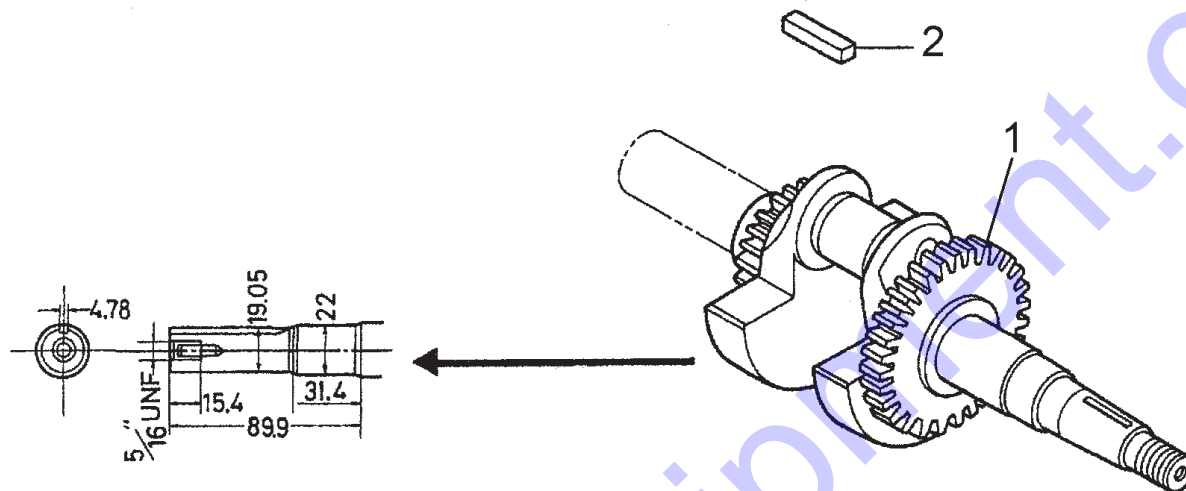

HONDA GX120K1QX2 ENGINE — CRANKSHAFT ASSY.

CRANKSHAFT ASSY.

<u>NO.</u>	<u>PART NO.</u>	<u>PART NAME</u>	<u>QTY.</u>	<u>REMARKS</u>
1	13310ZE0601	CRANKSHAFT, H-TYPE	1	
2	90745ZE1600	KEY 4.78 X4.78X38	1	

HONDA GX120K1QX2 ENGINE — CYLINDER BARREL ASSY.

CYLINDER BARREL ASSY.

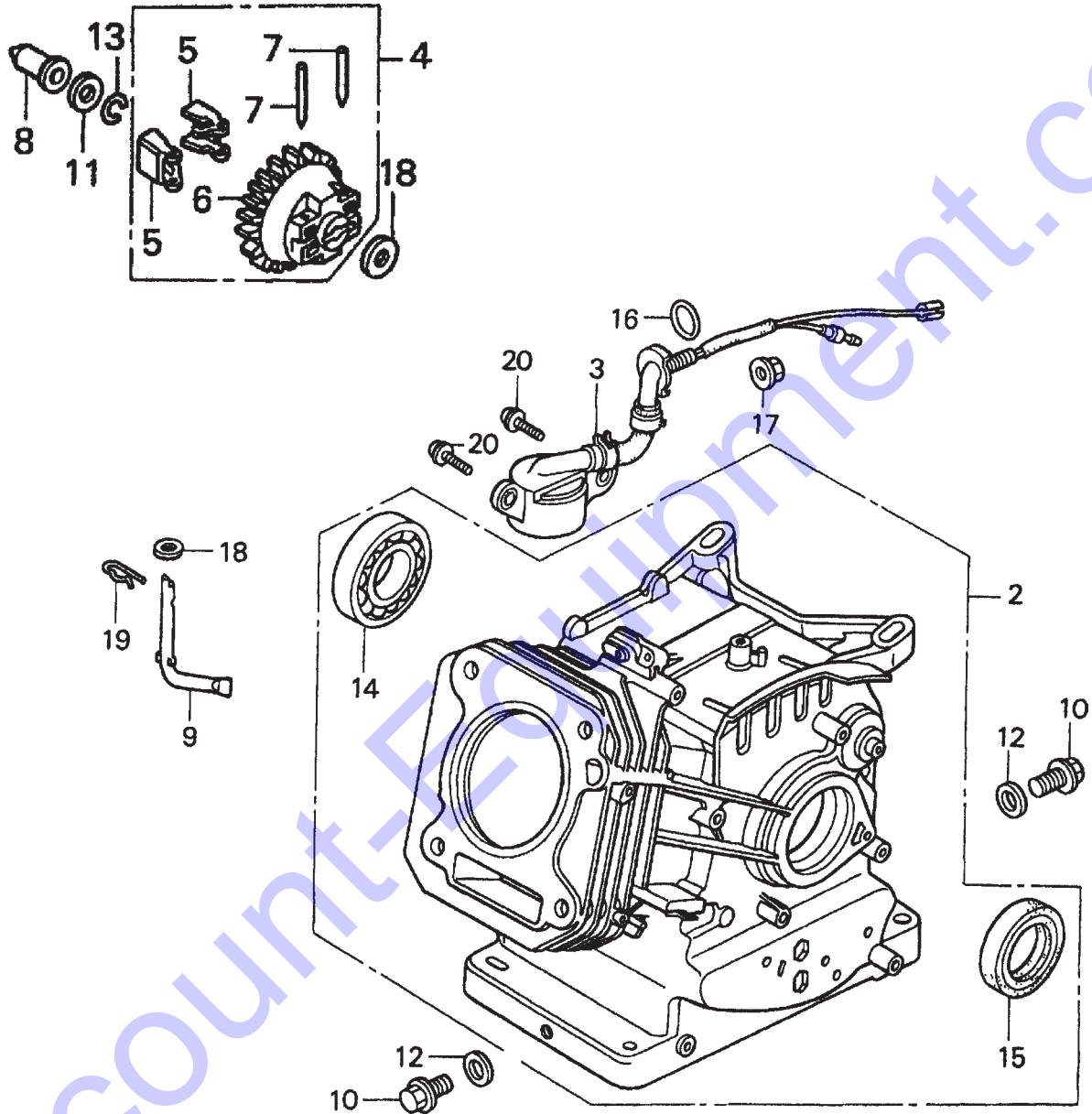

HONDA GX120K1QX2 ENGINE — CYLINDER BARREL ASSY.

CYLINDER BARREL ASSY.

<u>NO.</u>	<u>PART NO.</u>	<u>PART NAME</u>	<u>QTY.</u>	<u>REMARKS</u>
2	120A0ZH7810	CYLINDER ASSEMBLY (OIL ALERT)	1	INCLUDES ITEMS W/*
3	15510ZE1033	SWITCH ASSEMBLY, OIL LEVEL	1	
4	16510ZE1000	GOVERNOR ASSEMBLY	1	INCLUDES ITEMS W/#
5#	16511ZE1000	WEIGHT, GOVERNOR	2	
6#	16512ZE1000	HOLDER, GOVERNOR WEIGHT	1	
7#	16513ZE1000	PIN, GOVERNOR WEIGHT	2	
8	16531ZE1000	SLIDER, GOVERNOR	1	
9	16541ZE1000	SHAFT, GOVERNOR ARM	1	
10	90131ZE1000	BOLT, DRAIN PLUG	2	
11	90451ZE1000	WASHER, THRUST 6mm	1	
12	90601ZE1000	WASHER, DRAIN PLUG 10.2mm	2	
13	90602ZE1000	CLIP, GOVERNOR HOLDER	1	
14*	91001878003	BEARING, RADIAL BALL 62/22	1	
15*	91202ZE6003	OIL SEAL 22X35X6	1	
16	91353671003	O- RING 13.5X1.5 (ARAI)	1	
17	9405010000	NUT, FLANGE 10mm	1	
18	9410106800	WASHER, PLAIN 6mm	2	
19	9425108000	PIN, LOCK 8mm	1	
20	957010601200	BOLT, FLANGE 6X12	2	

HONDA GX120K1QX2 ENGINE — CYLINDER HEAD ASSY.

CYLINDER HEAD ASSY.

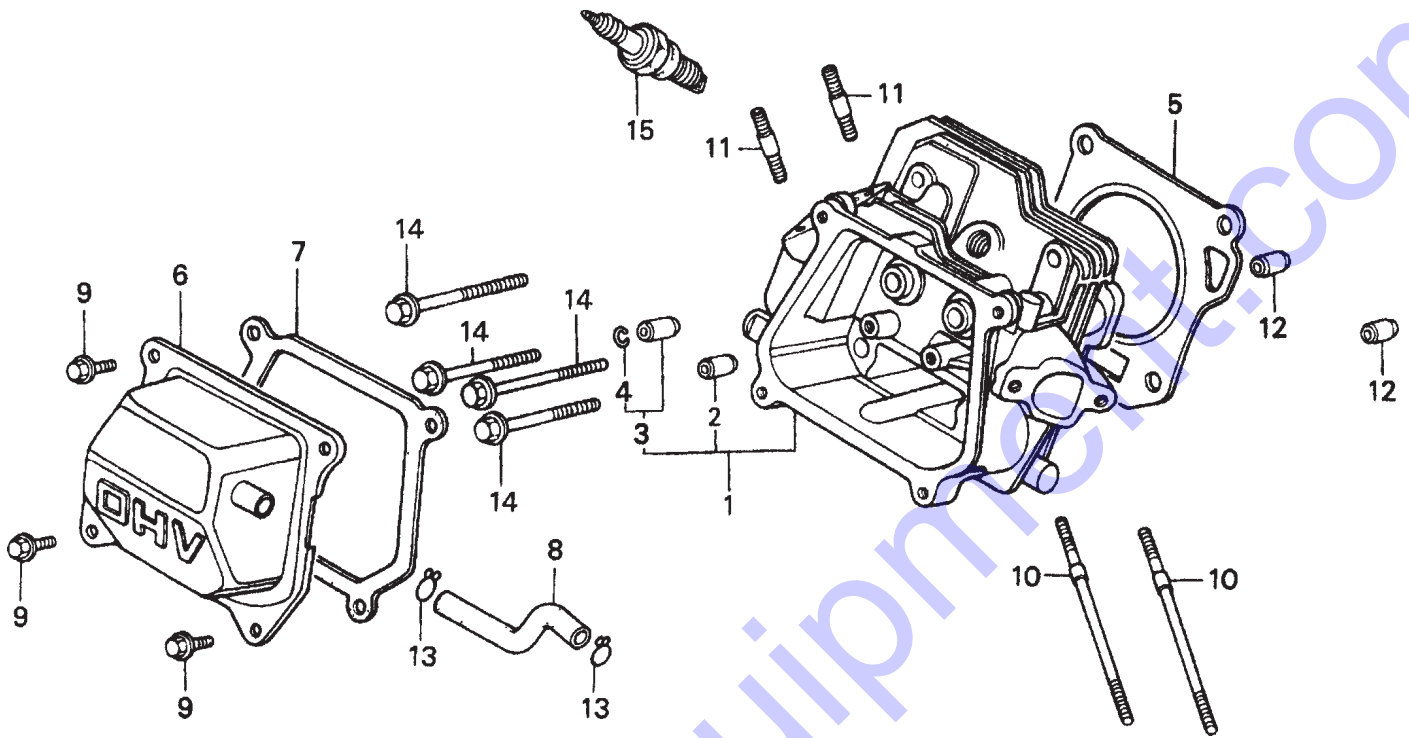

HONDA GX120K1QX2 ENGINE — CYLINDER HEAD ASSY.

CYLINDER HEAD ASSY.

<u>NO.</u>	<u>PART NO.</u>	<u>PART NAME</u>	<u>QTY.</u>	<u>REMARKS</u>
1	12210ZH7000	CYLINDER HEAD	1	INCLUDES ITEMS W/*
2*	12204ZE1306	GUIDE, VALVE (OS) OPTIONAL	1	
3*	12205ZE1315	GUIDE, EX. VALVE (OS) OPTIONAL	1	INCLUDES ITEMS W/+
4*+	12216ZE5300	CLIP, VALVE GUIDE	1	
5	12251ZH7800	GASKET, CYLINDER HEAD	1	
6	12310ZE1020	COVER, HEAD	1	
7	12391ZE1000	GASKET, CYLINDER HEAD COVER	1	
8	15721ZH8000	TUBE, BREATHER	1	
9	90013883000	BOLT, FLANGE 6X12 (CT200)	4	
10	90043ZE1020	BOLT, STUD 6X109	2	
11	90047ZE1000	BOLT, STUD 8X32	2	
12	9430110160	PIN, A, DOWEL 10X16	2	
14	957230805500	BOLT, FLANGE 8X55	4	
15	9807955846	SPARK PLUG BPR6ES (NGK)	1	

HONDA GX120K1QX2 ENGINE — FAN COVER ASSY.

FAN COVER ASSY.

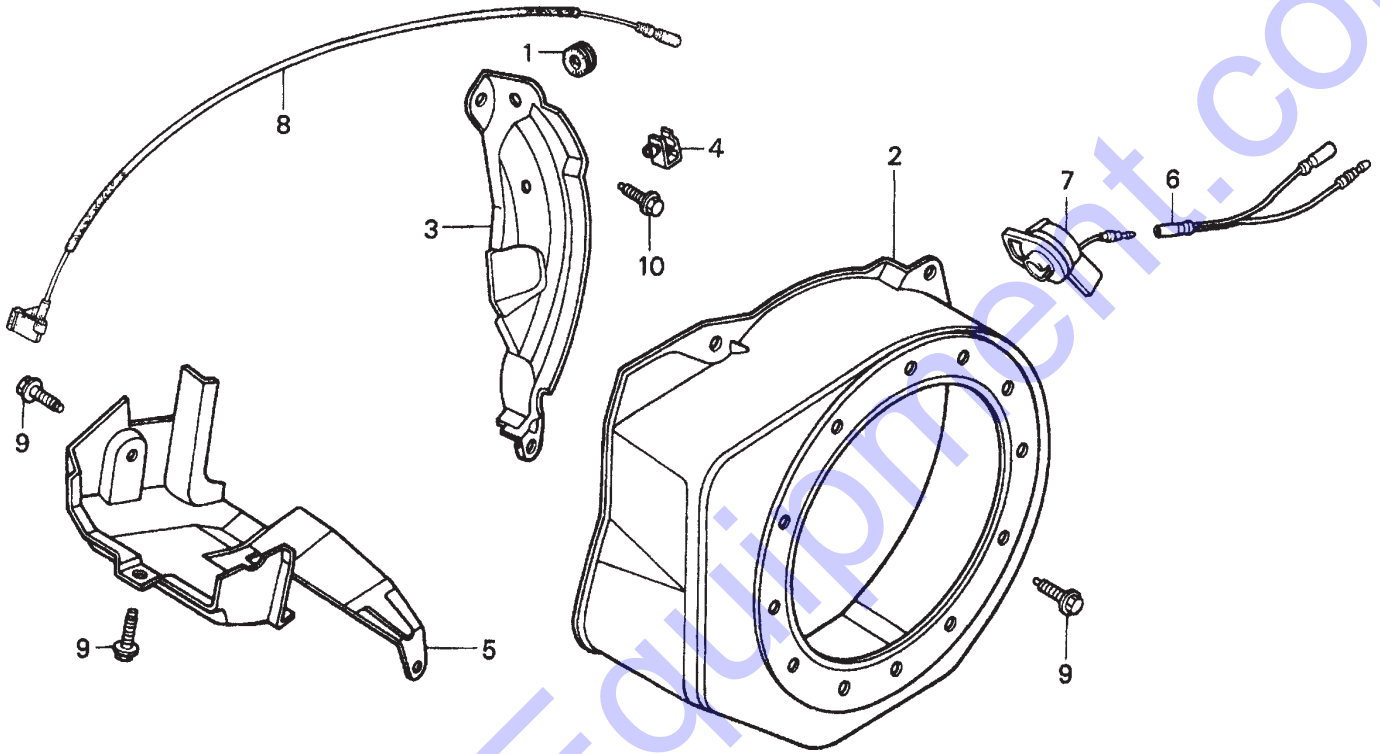

HONDA GX120K1QX2 ENGINE — FAN COVER ASSY.

FAN COVER ASSY.

<u>NO.</u>	<u>PART NO.</u>	<u>PART NAME</u>	<u>QTY.</u>	<u>REMARKS</u>
1	11347371300	GROMMET, ADJUSTING COVER	1	
2	19610ZE0000ZE	COVER, FAN *NH1* BLACK	1	
3	19611ZH7810	PLATE, SIDE (OIL ALERT)	1	
4	90601ZH7013	CLIP, HARNESS	1	
5	19630ZH7000	SHROUD	1	
6	32197ZH8003	SUB- HARNESS	1	
7	36100ZE1015	SWITCH ASSEMBLY, ENGINE STOP	1	
8	36101ZE1010	WIRE, STOP SWITCH 370MM	1	
9	90013883000	BOLT, FLANGE 6X12 (CT200)	6	
10	90022888010	BOLT, FLANGE 6X12 (CT200)	1	
11	34150ZH7003	ALERT UNIT, OIL	1	
13	957010600800	BOLT, FLANGE 6X8	1	

HONDA GX120K1QX2 ENGINE — FLYWHEEL ASSY.

FLYWHEEL ASSY.

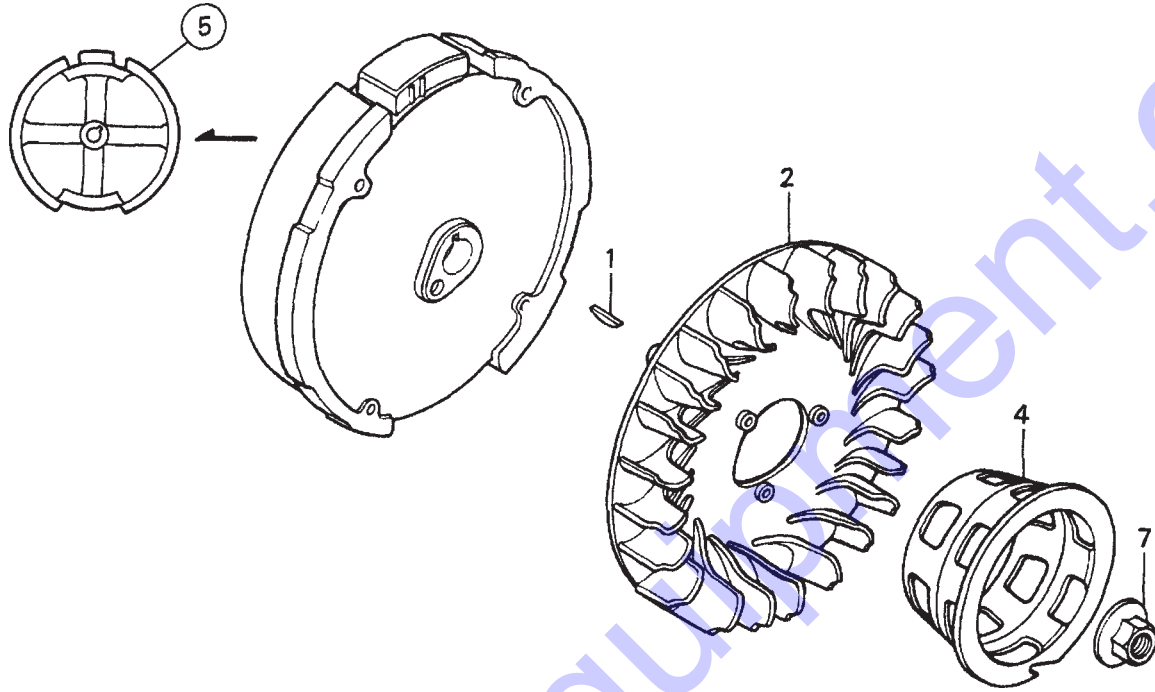

HONDA GX120K1QX2 ENGINE — FLYWHEEL ASSY.

FLYWHEEL ASSY.

<u>NO.</u>	<u>PART NO.</u>	<u>PART NAME</u>	<u>QTY.</u>	<u>REMARKS</u>
1	13331357000	KEY, SPECIAL WOODRUFF 25X18	1	
2	19511ZE0000	FAN, COOLING	1	
4	28451ZH8003	PULLEY, STARTER	1	
5	31100ZE0010	FLYWHEEL	1	
7	90201878003	NUT, SPECIAL 14MM	1	

HONDA GX120K1QX2 ENGINE — FUEL TANK ASSY.

FUEL TANK ASSY.

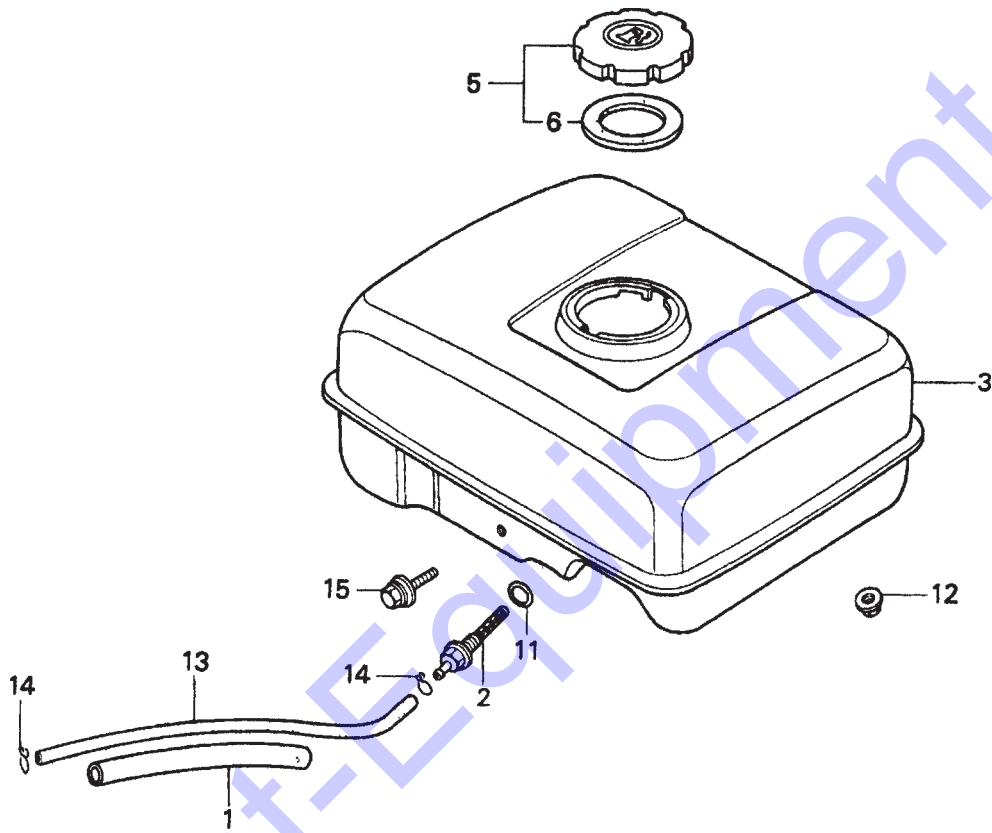

HONDA GX120K1QX2 ENGINE — FUEL TANK ASSY.

FUEL TANK ASSY.

<u>NO.</u>	<u>PART NO.</u>	<u>PART NAME</u>	<u>QTY.</u>	<u>REMARKS</u>
1	16854ZH8000	RUBBER, SUPPORTER 107MM	1	
2	16955ZE1000	JOINT, FUEL TANK	1	
3	17510ZE0020ZD	TANK, FUEL *NH1* (BLACK)	1	
5	17620ZH7023	CAP, FUEL FILLER	1	INCLUDES ITEMS W/*
6*	17631ZH7003	GASKET, FUEL FILLER CAP	1	
11	91353671003	O- RING 13.5X1.5 (ARAI)	1	
12	9405006000	NUT, FLANGE 6MM	2	
13	950014500360M	BULK HOSE, FUEL (4.5X3000) (4.5X140)	1	
14	9500202080	CLIP, TUBE (B8)	2	
15	90004ZH7003	BOLT, FLANGE 6X29	1	

HONDA GX120K1QX2 ENGINE — IGNITION COIL ASSY.

IGNITION COIL ASSY.

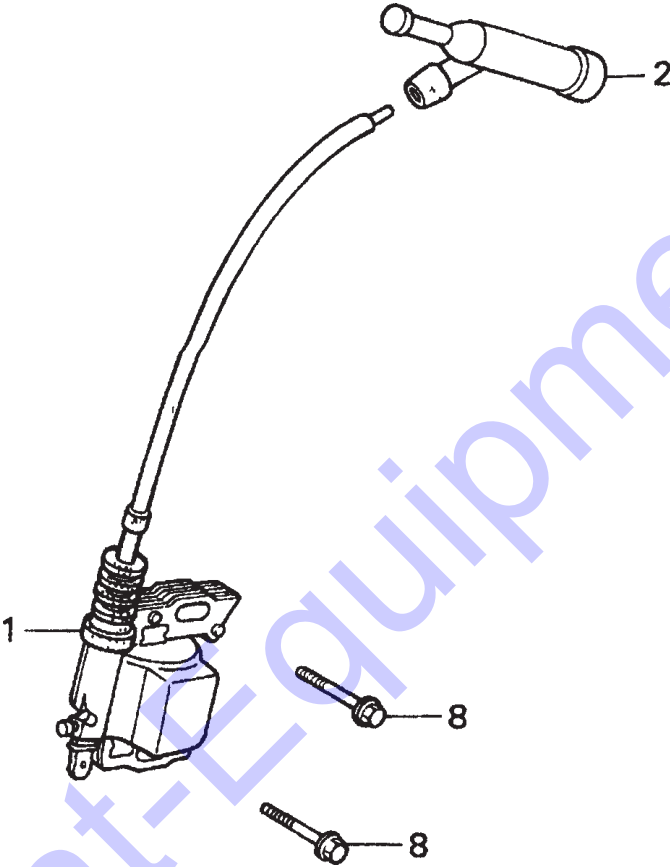

HONDA GX120K1QX2 ENGINE — IGNITION COIL ASSY.

IGNITION COIL ASSY.

<u>NO.</u>	<u>PART NO.</u>	<u>PART NAME</u>	<u>QTY.</u>	<u>REMARKS</u>
1	30500ZE1033	COIL ASSEMBLY, IGNITION	1	
2	30700ZE1013	CAP ASSEMBLY, NOISE SUPPRESSOR	1	
8	90121952000	BOLT, FLANGE 6X25	2	

HONDA GX120K1QX2 ENGINE — MUFFLER ASSY.

MUFFLER ASSY.

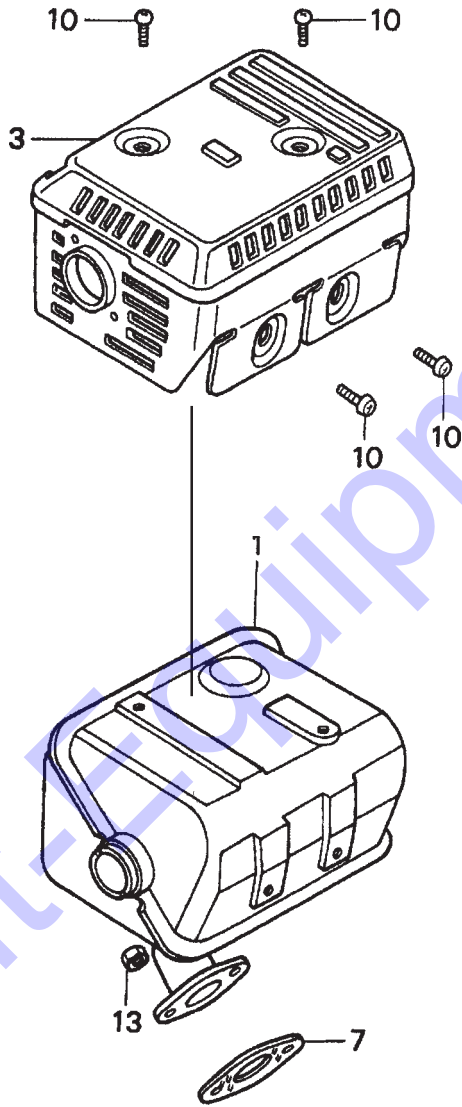

HONDA GX120K1QX2 ENGINE — MUFFLER ASSY.

MUFFLER ASSY.

<u>NO.</u>	<u>PART NO.</u>	<u>PART NAME</u>	<u>QTY.</u>	<u>REMARKS</u>
1	18310ZF1000	MUFFLER	1	
3	18320ZF1H01	PROTECTOR, MUFFLER	1	
7	18381ZH8800	GASKET, MUFFLER	1	
10	90050ZE1000	SCREW, TAPPING 5X8	4	
13	94001080000S	NUT, HEX. 8MM	2	

HONDA GX120K1QX2 ENGINE — PISTON ASSY.

PISTON ASSY.

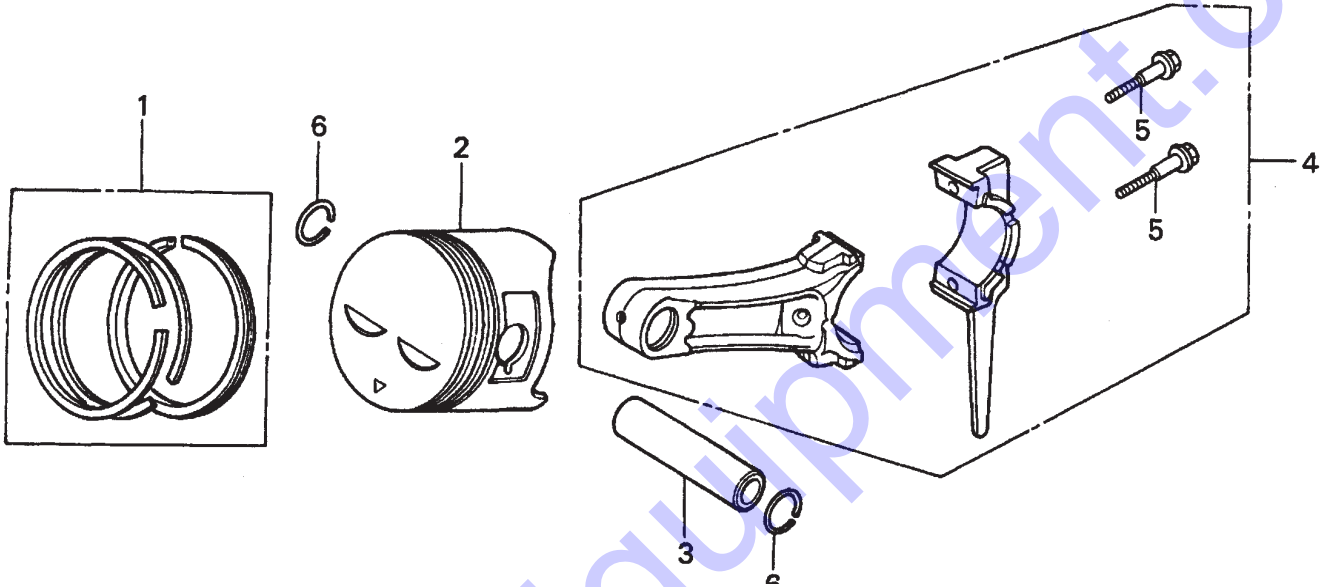

HONDA GX120K1QX2 ENGINE — PISTON ASSY.

PISTON ASSY.

<u>NO.</u>	<u>PART NO.</u>	<u>PART NAME</u>	<u>QTY.</u>	<u>REMARKS</u>
1	13010ZK7V01	RING SET, PISTON (STANDARD)	1	
1	13011ZE6013	RING SET, PISTON (OS 0.25), OPTIONAL	1	
1	13012ZK7V01	RING SET, PISTON (OS 0.50) , OPTIONAL	1	
1	13013ZK7V01	RING SET, PISTON (OS 0.75), OPTIONAL	1	
2	13101ZH7000	PISTON, STANDARD	1	
2	13102ZH7000	PISTON, OS 0.25	1	
2	13103ZH7000	PISTON, OS 0.50	1	
2	13104ZH7000	PISTON, 0.75	1	
3	13111ZE0000	PIN, PISTON	1	
4	132A0ZE0000	ROD ASSY, CONNECTING (UNDER SIZE)	1	INCLUDES ITEMS W/*
4	13200ZE0000	ROD ASSEMBLY, CONNECTING	1	INCLUDES ITEMS W/*
5*	90001ZE1000	BOLT, CONNECTING ROD	2	
6	90551ZE0000	CLIP, PISTON PIN 13MM	2	

HONDA GX120K1QX2 ENGINE — RECOIL STARTER ASSY.

RECOIL STARTER ASSY.

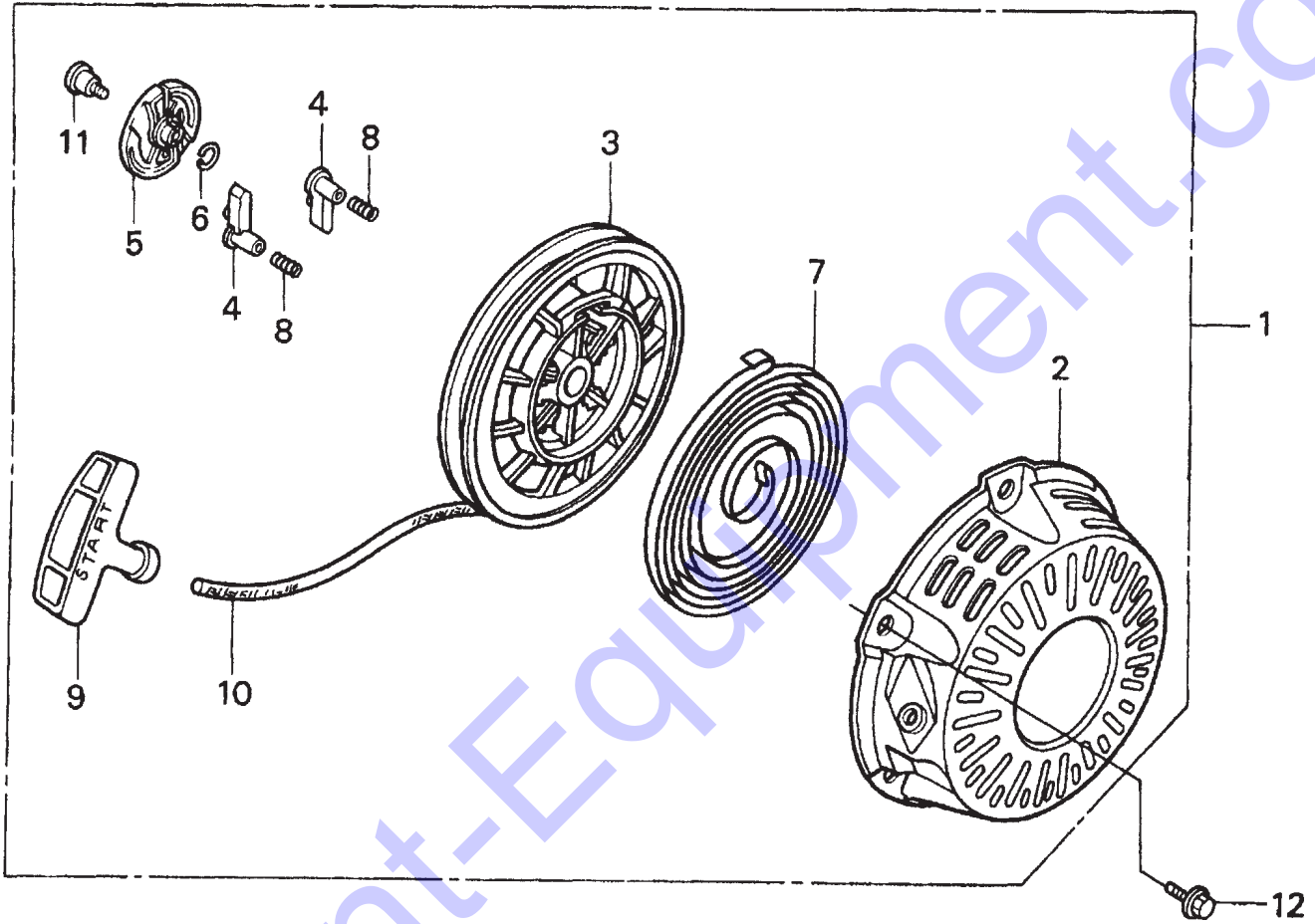

HONDA GX120K1QX2 ENGINE — RECOIL STARTER ASSY.

RECOIL STARTER ASSY.

<u>NO.</u>	<u>PART NO.</u>	<u>PART NAME</u>	<u>QTY.</u>	<u>REMARKS</u>
1	28400ZH8013ZB	STARTER ASSY., RECOIL *NH1* (BLACK)	1	INCLUDES ITEMS W/*
2*	28410ZH8003ZB	CASE, RECOIL STARTER *NH1* (BLACK)	1	
3*	28420ZH8013	REEL, RECOIL STARTER	1	
4*	28422ZH8013	RATCHET, STARTER	2	
5*	28433ZH8003	GUIDE, RATCHET	1	
6*	28441ZH8003	SPRING, FRICTION	1	
7*	28442ZH8003	SPRING, RECOIL STARTER	1	
8*	28443ZH8003	SPRING, RETURN	2	
9*	28461ZH8003	KNOB, RECOIL STARTER	1	
10*	28462ZH8003	ROPE, RECOIL STARTER	1	
11*	90003ZH8003	SCREW, SETTING	1	
12	9008ZE2003	BOLT, FLANGE 6X10	3	

NO ARTWORK AVAILABLE

HONDA GX120K1QX2 ENGINE — GASKET KIT ASSY.

GASKET KIT ASSY.

<u>NO.</u>	<u>PART NO.</u>	<u>PART NAME</u>	<u>QTY.</u>	<u>REMARKS</u>
2	06111ZH7405	GASKET KIT	1	INCLUDES ITEMS W/*
3*	11381ZH7800	GASKET, CASE COVER	1	
4*	12251ZH7800	GASKET, CYLINDER HEAD	1	
5*	12391ZE1000	GASKET, CYLINDER HEAD COVER	1	
6*	16212ZH7800	GASKET, INSULATOR	1	
7*	16221ZH8801	GASKET, CARBURETOR	1	
8*	18381ZH8800	GASKET, MUFFLER	1	

HONDA GX120K1QX2 ENGINE — LABELS ASSY.

LABELS ASSY.

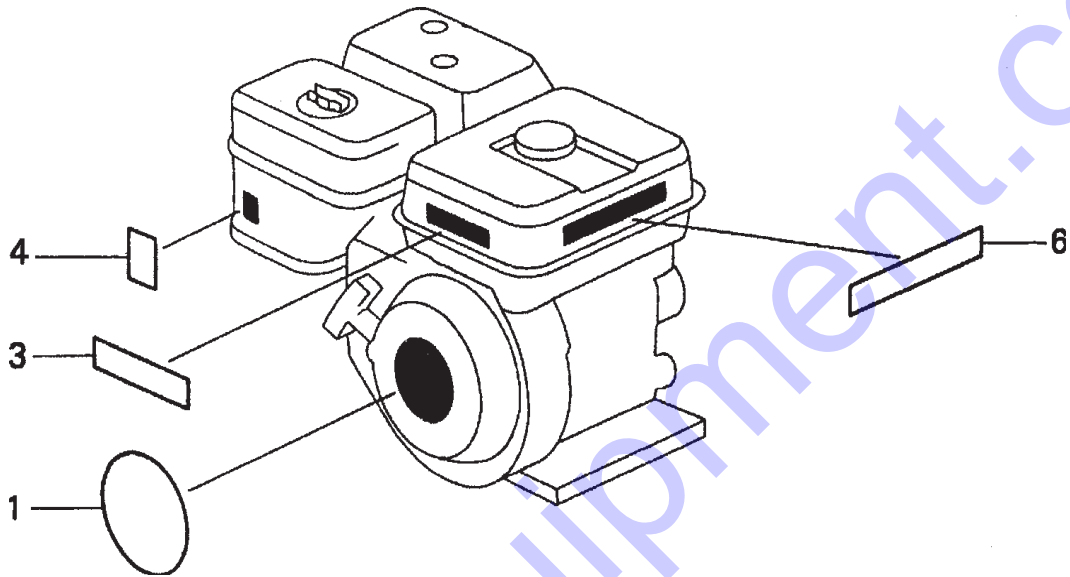

HONDA GX120K1QX2 ENGINE — LABELS ASSY.

LABELS ASSY.

<u>NO.</u>	<u>PART NO.</u>	<u>PART NAME</u>	<u>QTY.</u>	<u>REMARKS</u>
1	87521ZH7020	RING SET, PISTON (STANDARD)	1	
3	87522zH9000	LABEL CAUTION	1	
4	87528ZE1810	MARK CHOKE	1	
6	87532ZH8810	MARK, OIL ALERT		

Discount Equipment

Discount-Equipment.com is your online resource for commercial and industrial quality parts and equipment sales.

Locations:

Florida (West Palm Beach): [561-964-4949](tel:561-964-4949)

Outside Florida TOLL FREE: [877-690-3101](tel:877-690-3101)

Need parts? Check out our website at www.discount-equipment.com

Can't find what you need?

Click on this link: <http://www.discount-equipment.com/category/5443-parts/> and fill out the request form.

Please have the machine model and serial number available in order to help us get you the correct parts. One of our experienced staff members will get back to you with a quote for the right part that your machine needs.

We sell worldwide for the brands: Genie, Terex, JLG, MultiQuip, Mayco, Toro/Stone, Diamond Products, Magnum, Airman, Mustang, Power Blanket, Nifty Lift, Atlas Copco, Chicago Pneumatic, Allmand Brothers, Essick, Miller Spreader, Skyjack, Lull, Skytrak, Tsurumi, Husquvarna/Target, Whiteman-Concrete/Mortar, Stow-Concrete/Mortar, Baldor, Wacker, Sakai, Snorkel, Upright, Mi-T-M, Sullair, Neal, Basic, Dynapac, MBW, Weber, Bartell, Bennar Newman, Haulotte, Ditch Runner, Blaw-Knox, Himoina, Best, Buddy, Crown, Edco, Wyco, Bomag, Laymor, Terremite, Barreto, EZ Trench, Takeuchi, Basic, Bil-Jax, Curtis, Gehl, Heli, Honda, ICS/PowerGrit, Puckett, Waldon, ASV, IHI, Partner, Imer, Clipper, MMD, Koshin, Rice, Gorman Rupp, CH&E, Cat Pumps, Comet, General Pump, Giant, AMida, Coleman, NAC, Gradall, Square Shooter, Kent, Stanley, Tamco, Toku, Hatz, Kohler, Robin, Wisconsin, Northrock, Oztec, Toker TK, Rol-Air, Small Line, Wanco, Yanmar

New Equipment - Used Equipment - Rental Equipment - Parts and Accessories

Discount Equipment

www.discount-equipment.com

561-964-4949

Parts: wbparts@Discount-Equipment.com

Sales: info@Discount-Equipment.com