

OPERATION AND PARTS MANUAL



MODEL
MC94SH/MC94PH
MC94SE/MC94PE
CONCRETE MIXER
(HONDA GX240 SERIES GASOLINE ENGINES
AND 1.5 HP ELECTRIC MOTOR)

Revision #11 (06/07/18)



www.discount-equipment.com

THIS MANUAL MUST ACCOMPANY THE EQUIPMENT AT ALL TIMES.

Discount Equipment

Discount-Equipment.com is your online resource for commercial and industrial quality parts and equipment sales.

Locations:

Florida (West Palm Beach): [561-964-4949](tel:561-964-4949)

Outside Florida TOLL FREE: [877-690-3101](tel:877-690-3101)

Need parts? Check out our website at www.discount-equipment.com

Can't find what you need?

Click on this link: <http://www.discount-equipment.com/category/5443-parts/> and fill out the request form.

Please have the machine model and serial number available in order to help us get you the correct parts. One of our experienced staff members will get back to you with a quote for the right part that your machine needs.

We sell worldwide for the brands: Genie, Terex, JLG, MultiQuip, Mayco, Toro/Stone, Diamond Products, Magnum, Airman, Mustang, Power Blanket, Nifty Lift, Atlas Copco, Chicago Pneumatic, Allmand Brothers, Essick, Miller Spreader, Skyjack, Lull, Skytrak, Tsurumi, Husquvarna/Target, Whiteman-Concrete/Mortar, Stow-Concrete/Mortar, Baldor, Wacker, Sakai, Snorkel, Upright, Mi-T-M, Sullair, Neal, Basic, Dynapac, MBW, Weber, Bartell, Bennar Newman, Haulotte, Ditch Runner, Blaw-Knox, Himoinsa, Best, Buddy, Crown, Edco, Wyco, Bomag, Laymor, Terremite, Barreto, EZ Trench, Takeuchi, Basic, Bil-Jax, Curtis, Gehl, Heli, Honda, ICS/PowerGrit, Puckett, Waldon, ASV, IHI, Partner, Imer, Clipper, MMD, Koshin, Rice, Gorman Rupp, CH&E, Cat Pumps, Comet, General Pump, Giant, AMida, Coleman, NAC, Gradall, Square Shooter, Kent, Stanley, Tamco, Toku, Hatz, Kohler, Robin, Wisconsin, Northrock, Oztec, Toker TK, Rol-Air, Small Line, Wanco, Yanmar

New Equipment - Used Equipment - Rental Equipment - Parts and Accessories

Discount Equipment

www.discount-equipment.com

561-964-4949

Parts: wbparts@Discount-Equipment.com

Sales: info@Discount-Equipment.com

FUEL AND CHEMICAL EXPOSURE WARNINGS



WARNING

Gasoline engine exhaust and some of its constituents, and some dust created by power sanding, sawing, grinding, drilling and other construction activities contains chemicals known to the State of California to cause cancer, birth defects and other reproductive harm. Some examples of these chemicals are:

- Lead from lead-based paints.
- Crystalline silica from bricks.
- Cement and other masonry products.
- Arsenic and chromium from chemically treated lumber.

Your risk from these exposures varies, depending on how often you do this type of work. To reduce your exposure to these chemicals: **ALWAYS** work in a well ventilated area, and work with approved safety equipment, such as dust masks that are specially designed to filter out microscopic particles.

SILICOSIS/RESPIRATORY WARNINGS

⚠ WARNING



SILICOSIS WARNING

Grinding/cutting/drilling of masonry, concrete, metal and other materials with silica in their composition may give off dust or mists containing crystalline silica. Silica is a basic component of sand, quartz, brick clay, granite and numerous other minerals and rocks. Repeated and/or substantial inhalation of airborne crystalline silica can cause serious or fatal respiratory diseases, including silicosis. In addition, California and some other authorities have listed respirable crystalline silica as a substance known to cause cancer. When cutting such materials, always follow the respiratory precautions mentioned above.

⚠ WARNING

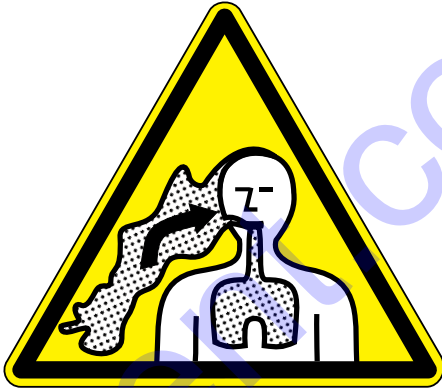

RESPIRATORY HAZARDS

Grinding/cutting/drilling of masonry, concrete, metal and other materials can generate dust, mists and fumes containing chemicals known to cause serious or fatal injury or illness, such as respiratory disease, cancer, birth defects or other reproductive harm. If you are unfamiliar with the risks associated with the particular process and/or material being cut or the composition of the tool being used, review the material safety data sheet and/or consult your employer, the material manufacturer/supplier, governmental agencies such as OSHA and NIOSH and other sources on hazardous materials. California and some other authorities, for instance, have published lists of substances known to cause cancer, reproductive toxicity, or other harmful effects.

Control dust, mist and fumes at the source where possible. In this regard use good work practices and follow the recommendations of the manufacturers or suppliers, OSHA/NIOSH, and occupational and trade associations. Water should be used for dust suppression when wet cutting is feasible. When the hazards from inhalation of dust, mists and fumes cannot be eliminated, the operator and any bystanders should always wear a respirator approved by NIOSH/MSHA for the materials being used.

TABLE OF CONTENTS

MC94P/S Series Concrete Mixers

Fuel And Chemical Exposure Warnings	2
Silicosis/Respiratory Warnings	3
Table Of Contents	4
Parts Ordering Procedures	5
Training Checklist	6
Safety Information	7-12
Mixer Specifications/Noise And Vibration	13
Engine/Electric Motor Specifications	14
General Information	15
Basic Components (Mixer)	16
Engine Components	17
Electric Motor Components	18-19
Towing Guidelines	20
Safety Chain Connection	21
Inspection	22-23
Start-Up	24-25
Operation	26-27
Maintenance (Engine)	28-31
Maintenance (Mixer)	31-34
Troubleshooting (Mixer)	35
Troubleshooting (Engine)	36-37
Explanation Of Code In Remarks Column	38
Suggested Spare Parts	39

Component Drawings

Nameplate And Decals Assembly	40-41
Plastic Barrel Assembly	42-43
Steel Barrel Assembly	44-45
Main Frame Assembly	46-47
Axle Assembly	48-49
Cabinet Assembly	50-51
Gas Engine Mounting Plate Assembly	52-53
Electric Motor Mounting Plate Assembly	54-55
Engine Service Parts	56-57
Terms And Conditions Of Sale — Parts	58

NOTICE

Specifications and part numbers are subject to change without notice.

TRAINING CHECKLIST

Training Checklist			
No,	Description	OK?	Date
1	Read operation manual completely.		
2	Machine layout, location of components, checking of engine oil levels.		
3	Fuel system, refueling procedure.		
4	Operation of controls (machine not running).		
5	Safety controls, safety stop switch operation.		
6	Emergency stop procedures.		
7	Machine transport and storage.		

SAFETY INFORMATION



Do not operate or service the equipment before reading the entire manual. Safety precautions should be followed at all times when operating this equipment. Failure to read and understand the safety messages and operating instructions could result in injury to yourself and others.







SAFETY MESSAGES

The four safety messages shown below will inform you about potential hazards that could injure you or others. The safety messages specifically address the level of exposure to the operator and are preceded by one of four words: **DANGER**, **WARNING**, **CAUTION** or **NOTICE**.

SAFETY SYMBOLS

 DANGER
<p>Indicates a hazardous situation which, if not avoided, WILL result in DEATH or SERIOUS INJURY.</p>
 WARNING
<p>Indicates a hazardous situation which, if not avoided, COULD result in DEATH or SERIOUS INJURY.</p>
 CAUTION
<p>Indicates a hazardous situation which, if not avoided, COULD result in MINOR or MODERATE INJURY.</p>
NOTICE
<p>Addresses practices not related to personal injury.</p>

Potential hazards associated with the operation of this equipment will be referenced with hazard symbols which may appear throughout this manual in conjunction with safety messages.

Symbol	Safety Hazard
	Lethal exhaust gas hazards
	Explosive fuel hazards
	Burn hazards
	Rotating parts hazards

SAFETY INFORMATION

GENERAL SAFETY

⚠ CAUTION

- **NEVER** operate this equipment without proper protective clothing, shatterproof glasses, respiratory protection, hearing protection, steel-toed boots and other protective devices required by the job or city and state regulations.



- Avoid wearing jewelry or loose fitting clothes that may snag on the controls or moving parts as this can cause serious injury.

- **NEVER** operate this equipment when not feeling well due to fatigue, illness or when under medication.



- **NEVER** operate this equipment under the influence of drugs or alcohol.



- **ALWAYS** clear the work area of any debris, tools, etc. that would constitute a hazard while the equipment is in operation.

- **ALWAYS** check the equipment for loosened threads or bolts before starting.

- **DO NOT** use the equipment for any purpose other than its intended purposes or applications.

NOTICE

- This equipment should only be operated by trained and qualified personnel 18 years of age and older.
- Whenever necessary, replace nameplate, operation and safety decals when they become difficult to read.
- Manufacturer does not assume responsibility for any accident due to equipment modifications. Unauthorized equipment modification will void all warranties.
- **NEVER** use accessories or attachments that are not recommended by Multiquip for this equipment. Damage to the equipment and/or injury to user may result.
- **ALWAYS** know the location of the nearest fire extinguisher.
- **ALWAYS** know the location of the nearest first aid kit.
- **ALWAYS** know the location of the nearest phone or **keep a phone on the job site**. Also, know the phone numbers of the nearest ambulance, doctor and fire department. This information will be invaluable in the case of an emergency.



SAFETY INFORMATION

MIXER SAFETY

DANGER

- **NEVER** operate the equipment in an explosive atmosphere or near combustible materials. An explosion or fire could result causing severe **bodily harm or even death.**



- **DO NOT** mix **flammable** or **explosive** substances.

WARNING

- **NEVER** place your hands inside the drum while starting or operating this equipment.
- **NEVER** disconnect any **emergency or safety devices.** These devices are intended for operator safety. Disconnection of these devices can cause severe injury, bodily harm or even death. Disconnection of any of these devices will void all warranties.
- Before operating mixer, ensure that safety grate is in position and correctly fitted.



CAUTION

- **NEVER** lubricate components or attempt service on a running machine.

NOTICE

- **ALWAYS** keep the machine in proper running condition.
- **ALWAYS** ensure mixer is on level ground before mixing.
- Fix damage to machine and replace any broken parts immediately.
- **DO NOT** tip mixer onto drum mouth when the drum is rotating.
- Ensure the drum is rotating while filling and emptying the drum.
- **ALWAYS** store equipment properly when it is not being used. Equipment should be stored in a clean, dry location out of the reach of children and unauthorized personnel.

ENGINE SAFETY (GASOLINE MODELS ONLY)

DANGER

- Engine fuel exhaust gases contain poisonous carbon monoxide. This gas is colorless and odorless, and can cause death if inhaled.
- The engine of this equipment requires an adequate free flow of cooling air. **NEVER** operate this equipment in any enclosed or narrow area where free flow of the air is restricted. If the air flow is restricted it will cause injury to people and property and serious damage to the equipment or engine.



WARNING

- **DO NOT** place hands or fingers inside engine compartment when engine is running.
- **NEVER** operate the engine with heat shields or guards removed.
- Keep fingers, hands hair and clothing away from all moving parts to prevent injury.
- **DO NOT** remove the engine oil drain plug while the engine is hot. Hot oil will gush out of the oil tank and severely scald any persons in the general area of the mixer.



CAUTION

- **NEVER** touch the hot exhaust manifold, muffler or cylinder. Allow these parts to cool before servicing equipment.
- Make certain the operator knows how to and is capable of turning the engine OFF in case of an emergency.



NOTICE

- **NEVER** run engine without an air filter or with a dirty air filter. Severe engine damage may occur. Service air filter frequently to prevent engine malfunction.
- **NEVER** tamper with the factory settings of the engine or engine governor. Damage to the engine or equipment can result if operating in speed ranges above the maximum allowable.



SAFETY INFORMATION

FUEL SAFETY (GASOLINE MODELS ONLY)

DANGER

- **DO NOT** start the engine near spilled fuel or combustible fluids. Fuel is extremely flammable and its vapors can cause an explosion if ignited.
- **ALWAYS** refuel in a well-ventilated area, away from sparks and open flames.
- **ALWAYS** use extreme caution when working with **flammable** liquids.
- **DO NOT** fill the fuel tank while the engine is running or hot.
- **DO NOT** overfill tank, since spilled fuel could ignite if it comes into contact with hot engine parts or sparks from the ignition system.
- Store fuel in appropriate containers, in well-ventilated areas and away from sparks and flames.
- **NEVER** use fuel as a cleaning agent.
- **DO NOT** smoke around or near the equipment. Fire or explosion could result from fuel vapors or if fuel is spilled on a hot engine.



GENERATOR SAFETY

If using a generator to power mixer, refer to applicable generator manual safety information section.



ELECTRIC MOTOR SAFETY (ELECTRIC MODELS ONLY)

NOTICE

- Operate electric motor only at the specified voltage indicated on the nameplate.
- **DO NOT** spray water onto electric motor.
- **ALWAYS** disconnect AC power plug from power source before moving mixer.
- **ALWAYS** make sure the ON/OFF switch on the electric motor is in the OFF position when not in use and before inserting the mixer's power plug into an AC receptacle.



Power Cord/Cable Safety

DANGER

- **NEVER** let power cords or cables **lay in water**.
- **NEVER** use **damaged** or **worn** cables or cords when connecting equipment to generator. Inspect for cuts in the insulation.
- **NEVER** grab or touch a live power cord or cable with wet hands. The possibility exists of **electrical shock, electrocution or death**.
- Make sure power cables are securely connected. Incorrect connections may cause electrical shock and damage to the mixer.

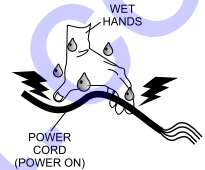

CAUTION

- Ensure that cables and cords will not be tripped over or trapped underneath the mixer.

NOTICE

- **ALWAYS** make certain that proper power or extension cord has been selected for the job.

TRANSPORTING SAFETY

CAUTION

- **NEVER** allow any person or animal to stand underneath the equipment while lifting.

NOTICE

- **ALWAYS** make sure forklift forks are inserted into pockets (if applicable) as far as possible when lifting the mixer.
- **ALWAYS** shutdown engine before transporting.
- **NEVER** lift the equipment while the engine is running.
- Tighten fuel tank cap securely and close fuel cock to prevent fuel from spilling.
- **DO NOT** lift machine to unnecessary heights.
- **ALWAYS** tie down equipment during transport by securing the equipment with rope.
- **NEVER** tip the engine to extreme angles during lifting as it may cause oil to gravitate into the cylinder head, making the engine start difficult.

SAFETY INFORMATION

TOWING SAFETY

CAUTION

- Check with your local county or state safety towing regulations, in addition to meeting **Department of Transportation (DOT) Safety Towing Regulations**, before towing your mixer.
- In order to reduce the possibility of an accident while transporting the mixer on public roads, **ALWAYS** make sure the towing vehicle is mechanically sound and in good operating condition.
- **ALWAYS** shutdown engine before transporting and place the fuel valve in the **OFF** position.
- **ALWAYS** inspect the hitch and coupling for wear. **NEVER** tow a mixer with defective hitches, couplings, chains, etc.
- Check the tire air pressure on both towing vehicle and mixer **Mixer tires should be inflated to 50 psi cold**. Also check the tire tread wear on the vehicle and mixer.
- **ALWAYS** make sure the mixer is equipped with a **safety chain**.
- **ALWAYS** properly attach mixer's safety chains to towing vehicle.
- The maximum speed for highway towing is **55 MPH** unless posted otherwise. Recommended off-road towing is not to exceed **15 MPH** or less depending on type of terrain.
- Avoid sudden stops and starts. This can cause skidding, or jack-knifing. Smooth, gradual starts and stops will improve towing.
- Avoid sharp turns to prevent rolling.
- Mixer should be adjusted to a level position at all times when towing.
- Raise and lock mixer wheel stand in up position when towing.
- Place **chock blocks** underneath wheel to prevent **rolling** while parked.

ENVIRONMENTAL SAFETY/DECOMMISSIONING

NOTICE

Decommissioning is a controlled process used to safely retire a piece of equipment that is no longer serviceable. If the equipment poses an unacceptable and unrepairable safety risk due to wear or damage or is no longer cost effective to maintain (beyond life-cycle reliability) and is to be decommissioned (demolition and dismantlement), be sure to follow rules below.

- **DO NOT** pour waste or oil directly onto the ground, down a drain or into any water source.
- Contact your country's Department of Public Works or recycling agency in your area and arrange for proper disposal of any electrical components, waste or oil associated with this equipment.
- When the life cycle of this equipment is over, remove battery if equipped and bring to appropriate facility for lead reclamation. Use safety precautions when handling batteries that contain sulfuric acid.
- When the life cycle of this equipment is over, it is recommended that the mixer frame and all other metal parts be sent to a recycling center.



Metal recycling involves the collection of metal from discarded products and its transformation into raw materials to use in manufacturing a new product.

Recyclers and manufacturers alike promote the process of recycling metal. Using a metal recycling center promotes energy cost savings.

EMISSIONS INFORMATION

NOTICE

The gasoline engine used in this equipment has been designed to reduce harmful levels of carbon monoxide (CO), hydrocarbons (HC) and nitrogen oxides (NOx) contained in gasoline exhaust emissions.

This engine has been certified to meet US EPA Evaporative emissions requirements in the installed configuration.

Attempting to modify or make adjustments to the engine emission system by unauthorized personnel without proper training could damage the equipment or create an unsafe condition.

Additionally, modifying the fuel system may adversely affect evaporative emissions, resulting in fines or other penalties.

Emission Control Label

The emission control label is an integral part of the emission system and is strictly controlled by regulation(s).

The label must remain with the engine for its entire life.

If a replacement emission label is needed, please contact your authorized engine distributor.

MIXER SPECIFICATIONS/NOISE AND VIBRATION

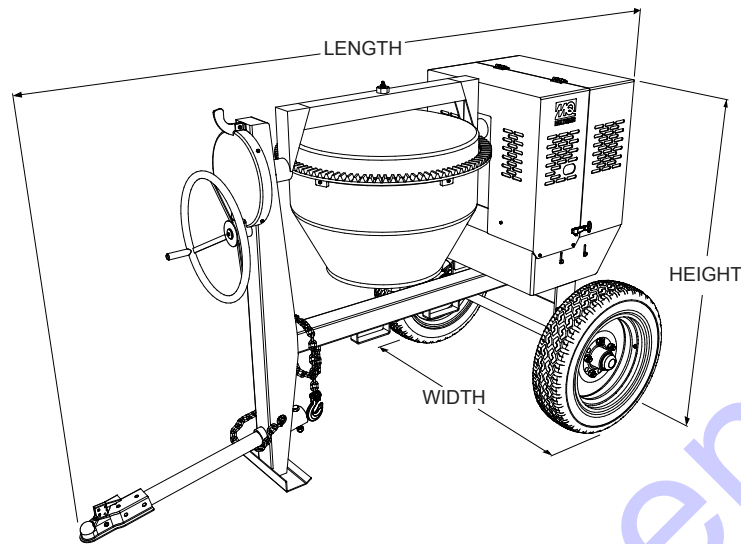

Figure 1. Dimensions

Table 1. MC94SP Series Specifications/Dimensions	
Height	63 in. (1,600 mm)
Width	51 in. (1,296 mm)
Length	103 in. (2,616 mm)
Maximum Mixing Capacity	9 cu. ft. (170 liters)
Bag Capacity	1 to 1.5 bag
Weight - With Engine/ Electric Motor	755 lbs. (342 Kg.)

Table 2. MC94SP Noise And Vibration (Gasoline Only)	
Guaranteed ISO 11201:2010 Based Sound Pressure Level at Operator Station in dB(A)	TBD
Guaranteed ISO 3744:2010 Based Sound Power Level in dB(A)	TBD

NOTES:

1. Sound Pressure and Power Levels are "A" weighted Measures per ISO 226:2003 (ANSI S1.4-1981). They are measured with the operating condition of the machine which generates the most repeatable but highest values of the sound levels. Under normal circumstances, the sound level will vary depending on the condition of the material being worked upon.
2. The vibration level indicated is the vector sum of the RMS (Root Mean Square) Values of amplitudes on each axis, standardized to an 8 hour exposure period, and obtained using operating condition of the machine that generates the most repeatable but highest values in accordance with the applicable standards for the machine.

ENGINE/ELECTRIC MOTOR SPECIFICATIONS

Table 3. Engine/Electric Motor Specifications		
Model	HONDA GX240K1QX2 GX240UT1QA2	Baldor 35LYL229
Type	Air-cooled 4 stroke, Single Cylinder, OHV, Horizontal Shaft Gasoline Engine	1.5 HP, 1Ø-120/240 VAC, Electric Motor
Bore X Stroke	2.9 in. X 2.3 in. (73 mm x 58 mm)	N/A
Displacement	14.81 cu. in. (242 cc)	N/A
Max Output	8.0H.P./3,600 rpm	1.5 HP/1725 R.P.M.
Fuel Tank Capacity	1.59 U.S. Gallons (6.0 Liters)	N/A
Fuel	Unleaded Automobile Gasoline	N/A
Lube Oil Capacity	1.16 qt. (1.1 liter)	N/A
Speed Control Method	Centrifugal Fly-weight Type	N/A
Starting Method	Recoil Start	Electric
Input Voltage	N/A	120/240 VAC, 1Ø
Dimension (L x W x H)	14.0 x 16.9 X 16.1 in. (355 X 430 X 410 mm)	15.55 x 8.65 X 9.06 in. (395 X 220 X 230 mm)
Dry Net Weight	55.1 lbs (25.0 Kg.)	Approx. 12 lbs (5.4 kg.)

Table 4. Mixing Hints								
Applications	Mix Ratios	Batch Quantities					Approx. Batch Output	
		Cement Bag 112 lb (50 Kg)	Sand		Stone			
			Cu. Ft.	Ltr	Cu. Ft.	Ltr	Cu. Ft.	Ltr
Most Ordinary	1:2:4	1/2 Bag	1¼	35	2½	71	3	85
Foundations	1:3:6	1/3 Bag	1¼	35	2½	71	2¾	78
Rough Mass Concrete	1:4:8	1/4 Bag	1¼	35	2½	71	2¾	78
Watertight Floors, Tanks, Pits, etc.	1:1½:3	2/3 Bag	1¼	35	3	71	3	85

GENERAL INFORMATION

APPLICATION

This mixer is **only** intended for the production of **concrete**. The mixer must be used for its intended purpose and is not suitable for the mixing of **flammable** or **explosive** substances. The mixer **must not be used** in an explosive atmosphere. Use Table 4 (Mixing Hints) as a guide when mixing concrete for various applications.

POWER PLANTS

The mixer can be powered by a Honda GX240 air-cooled, 4-stroke gasoline engine or a 1.5 HP electric motor. Refer to Table 3 to for specific engine or electric motor data information.

ELECTRICAL

If mixer is equipped with an **electric motor**, make sure that the power being supplied to the motor corresponds to the voltage rating label on the motor. Supplying the wrong voltage to the electric motor will cause severe electrical damage to the motor.

Always make sure the **OFF/ON** switch on the electric motor is in the **OFF** position before applying power.

It is **strongly recommended** when inserting the mixer's power cord into a receptacle, that a G.F.C.I. (**Ground Fault Current Interrupter**) receptacle be used (120 VAC applications).

HARDWARE

Check all hardware on the mixer **before starting**. Periodically inspect all hardware. Loose hardware can contribute to early component failure and poor performance. Use Table 5 as general guideline when the torquing of mixer hardware is required. Remember to keep all mixer hardware components tight.

Table 5. Hardware Torque Recommendations

Hardware Diameter	Torque (ft-lbs)
5/16-inch x 18	14
3/8-inch x 16	24
3/8-inch x 24	37
1/2-inch x 13	39
1/2-inch x 13 (Grade 8)	90

ENGINE MAINTENANCE

For basic engine maintenance, refer to the engine maintenance section in this manual. For more detailed engine maintenance, refer to the Honda Engine Owner's manual furnished with the engine.

OPTIONAL TOW BARS

This mixer can be configured for use with various types of tow bars (ball, loop and pin). Reference Figure 2. Contact MQ sales department for the desired tow bar.

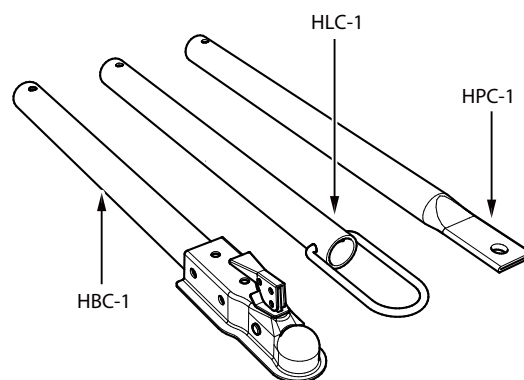

OPTIONAL TOWING BARS

Figure 2. Optional Tow Bars

BASIC COMPONENTS (MIXER)

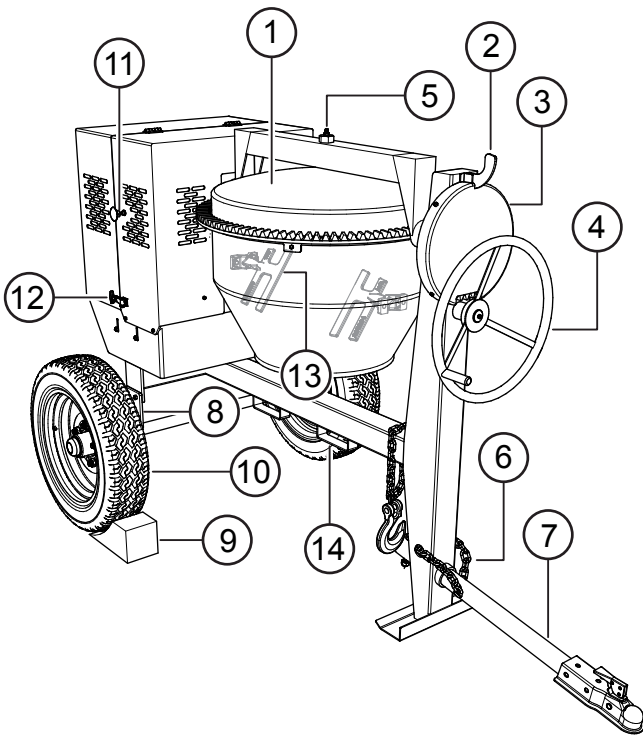

Figure 3. Mixer Major Components

1. **Steel Mixing Drum** — This mixer uses a 6 cu. ft **steel** mixing drum. This drum is to be used for mixing of concrete. Always clean the drum after each use. **DO NOT** use this mixing drum for the mixing of volatile liquids.
2. **Dump Latch** — To rotate the mixing drum, this latch must be in the up position. To lock the drum, place the latch in the down position.
3. **Dump Gear Guard** — **NEVER** operate the mixer with this guard removed. Its purpose is to prevent dirt and debris from entering the dump gear. In addition, operator clothing could become entangled in the dump gear, causing severe injury and bodily harm.
4. **Handwheel** — Turn this wheel clockwise or counter-clockwise to rotate the mixing drum. Remember the dump latch must be in the **up position** in order for the mixing drum to be rotated.
5. **Zerk Fittings** — There are **four** grease zerk fittings that require lubrication, three are on the **yoke**, and the remaining fitting is located in the center of the **handwheel**. Lubricate these fittings as referenced in the maintenance section of this manual.
6. **Safety Chain** — This mixer uses a 3/16-inch thick, 72-inches long zinc-plated safety chain. **ALWAYS** connect the safety chain when towing.
7. **Tow Bar** — This mixer uses various towing bars, please reference the frame assembly drawing and parts list in this manual to determine which tow bar meets your requirements.
8. **Spring Suspension** — This mixer uses a **spring** type suspension. Check the mounting hardware for bolt hole elongation and tightness. See maintenance section of this manual for recommended maintenance.
9. **Chock Blocks** — Place these blocks (not included as part of the mixer package) under each mixer wheel to prevent rolling, when mixer is not connected to the towing vehicle.
10. **Tires Ply** — The tire ply (layers) number is rated in letters. This mixer uses 13-inch 2-ply tires. Replace with only recommended type tires.
11. **ON/OFF Switch (gasoline only)** — This switch is provided on *mixer with gasoline* engines only and is located on the side of the mixer cabinet. When activated it will shut down the engine. Pull out when starting the engine.
12. **Cabinet/Latch** — Encloses engine and electric motor. **NEVER** run mixer with cabinet removed. Use latches to secure engine compartment cabinet.
13. **Mixing Blades (Steel)** — Used for the mixing of concrete. When blades show signs of wear, entire steel mixing drum assembly must be replaced. See steel mixing drum assembly in the parts section of this manual.
14. **Forklift Pockets** — When lifting of the mixer is required, use these fork lift pockets to lift the mixer. Remember to insert the forks of the forklift a minimum of 24 inches into the lift pockets.

ENGINE COMPONENTS

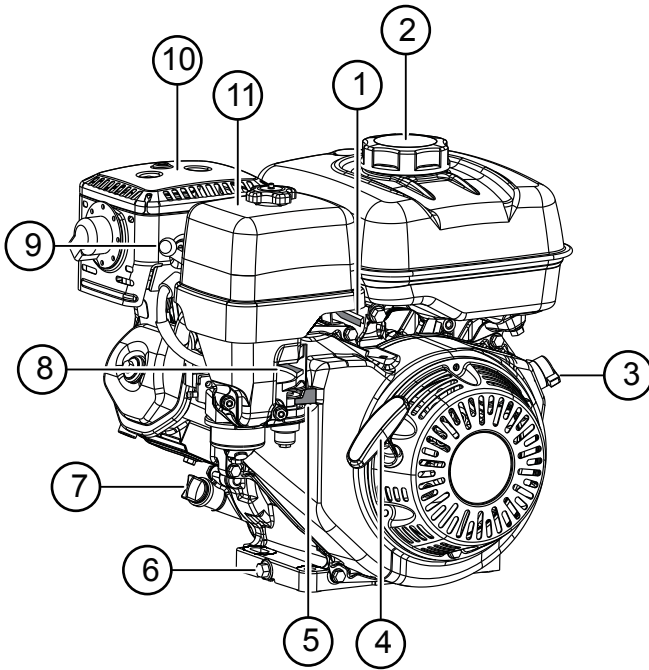

Figure 4. Engine Components

INITIAL SERVICING

The engine (Figure 4) must be checked for proper lubrication and filled with fuel prior to operation. Refer to the manufacturer's engine manual for instructions and details of operation and servicing.

1. **Throttle Lever** – Used to adjust engine RPM speed.
2. **Fuel Filler Cap/Fuel Tank** – Remove this cap to add unleaded gasoline to the fuel tank. Fill with unleaded gasoline. Refer to Table 3 for fuel tank capacity. Make sure cap is tightened securely. **DO NOT** over fill. For additional information, refer to Honda engine owner's manual.

DANGER



Add fuel to the tank only when the engine is stopped and has had an opportunity to cool down. In the event of a fuel spill, **DO NOT** attempt to start the engine until the fuel residue has been completely wiped up and the area surrounding the engine is dry.

3. **Engine On/Off Switch** – **ON** position permits engine starting, **OFF** position stops engine operation.
4. **Recoil Starter (pull rope)** – Manual-starting method. Pull the starter grip until resistance is felt, then pull briskly and smoothly.
5. **Fuel Valve Lever** – **OPEN** to let fuel flow, **CLOSE** to stop the flow of fuel.
6. **Oil Drain Plug** – Remove this plug to remove oil from the engine's crankcase.
7. **Dipstick/Oil Filler Cap** – Remove this cap to determine if the engine oil is low. Add oil through this filler port as recommended in Table 7.
8. **Choke Lever** – Used in the starting of a cold engine, or in cold weather conditions. The choke enriches the fuel mixture.
9. **Spark Plug** – Provides spark to the ignition system. Set spark plug gap according to engine manufacturer's instructions. Clean spark plug once a week.
10. **Muffler** – Used to reduce noise and emissions. **NEVER** touch when *hot!*
11. **Air Cleaner** – Prevents dirt and other debris from entering the fuel system. Remove wing-nut on top of air filter canister to gain access to filter element.

NOTICE

Operating the engine without an air filter, with a damaged air filter or a filter in need of replacement, will allow dirt to enter the engine, causing rapid engine wear.

ELECTRIC MOTOR COMPONENTS

ELECTRIC MOTOR

For lubrication care and operation of the electric motor, refer to your electric motor instruction booklet furnished with the motor.

Protect the electric motor from dust as much as possible and keep ventilating openings clean.

CAUTION

DO NOT spray water at any time on the electric motor.
DO NOT operate electric motor in an explosive environment.

The electric motor used on this mixer is single-phase, 1/2 HP @120 VAC motor. Pay special attention to the nameplate on the electric motor when supplying power to the electric motor. Applying incorrect power to the motor can severely damage the motor and **may cause serious bodily injury!**

Always make certain that the correct voltage is being supplied to the motor. The input voltage requirements can be found on the electric motor's nameplate.

ELECTRIC MOTOR POWER CONNECTIONS

A 12-inch electrical cable (Figure 6) is provided with the electrical motor for hookup to a power source.

The electric motor supplied with the mixer is configured from the factory for 120 VAC grounded operation.

Motors can burn out when the line voltage falls 10% below the voltage rating of the motor. Failure to use proper voltage will cause the motor to overheat and actuate the overload switch.

If overload protection should actuate because of improper voltage or any other malfunction, turn the main switch on the motor to the "OFF" position and correct the problem, press the reset switch button, and turn the main switch to the "ON" position.

NOTICE

It is strongly recommended that all electrical wiring be done by a **licensed electrician**. Pay special attention to the nameplate on the electric motor. Make certain that the voltage supplied to the electric motor matches the required operating voltage printed on the nameplate.

ELECTRIC MOTOR VOLTAGE CHANGE SWITCH

- ALWAYS** make certain the electric motor's ON/OFF switch is in the "OFF" position and the power cord has been disconnected from the power source.
- Remove the voltage change lock-out bolt and nut (Figure 5). Change the position of the voltage change toggle switch from 120 VAC to 240 VAC. The mixer is factory wired for 120 VAC operation.
- Re-install the voltage change lock-out bolt and nut.

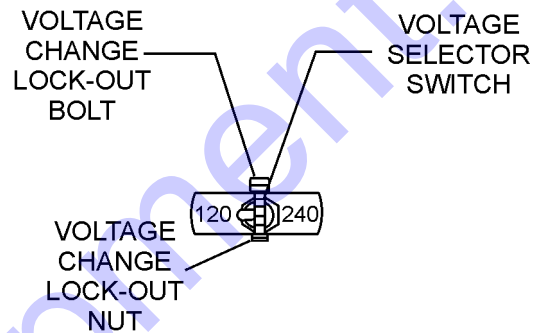

Figure 5. Voltage Change Switch

- Important!**, when changing the input voltage to the electric motor from 120 to 240 VAC, the plug on the electric motor power cord must also be changed. See Table 6 and Figure 6.

Table 6. Electric Motor Wiring Information

120-240 VAC -Single Phase		
Motor HP Rating	NEMA Plug Connector	Mating NEMA Connector
1.5 HP (120 VAC)	L5-20P P/N EM940537	L5-20R P/N EM940538
1.5 HP (240 VAC)	L6-20P P/N 940539	L6-20R P/N 940540

NOTICE

ALWAYS make certain the electric motor's ON/OFF switch is working properly. When the mixer is not in use, place the ON/OFF switch in the "OFF" position and disconnect the power cord from the power source.

ELECTRIC MOTOR COMPONENTS

CAUTION

NEVER disable or disconnect the **ON/OFF** switch on the electric motor. It is provided for operator safety. Injury may result if it is disabled, disconnected or improperly maintained.

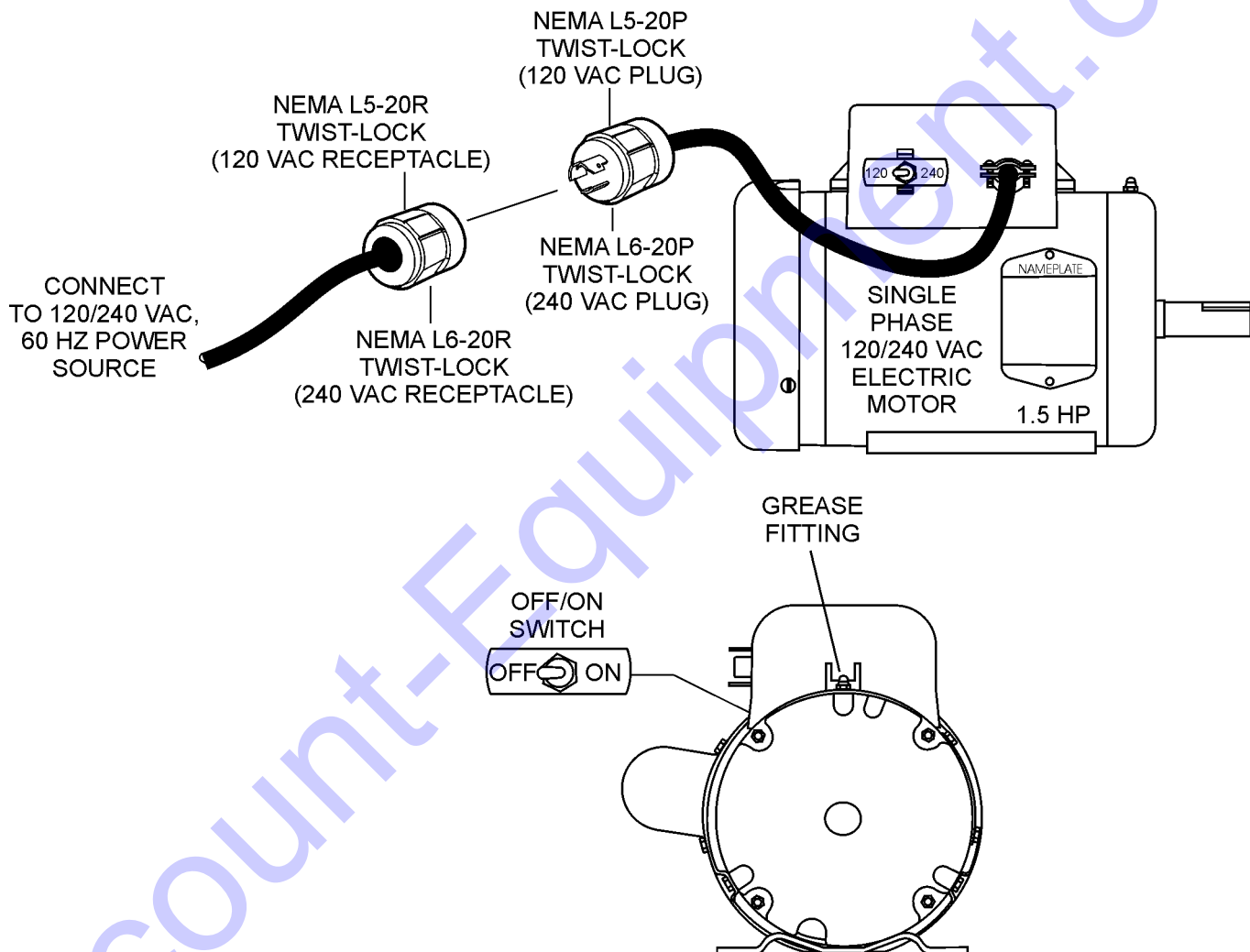

Figure 6. Electric Motor

TOWING GUIDELINES

TOWING SAFETY PRECAUTIONS

CAUTION

Check with your county or state safety towing regulations department before towing your *mixer*.

To reduce the possibility of an accident while transporting the mixer on public roads, always make sure that the mixer towing components and the towing vehicle are in good operating condition and both units are mechanically sound.

The following list of suggestions should be used when towing the mixer:

- Make sure that the hitch and coupling of the towing vehicle are rated equal to, or greater than the trailer "gross vehicle weight rating" (GVWR).
- **ALWAYS** inspect the hitch and coupling for wear. **NEVER** tow the mixer with defective hitches, couplings, chains etc.
- **CHECK** the tire air pressure on both the towing vehicle and the trailer. Also check the tire tread wear on both vehicles.
- **ALWAYS** make sure the mixer is equipped with a "Safety Chain."
- **ALWAYS** attach trailer's safety chain to the frame of towing vehicle.
- **ALWAYS** make sure that the towing vehicle's directional, backup, and brake lights are working properly.
- Remember in most cases the maximum speed unless otherwise posted for highway towing is **55 MPH**, however before towing your mixer, check your local state, and county vehicle towing requirements. Recommended off-road towing is not to exceed **15 MPH** or less depending on type of terrain.
- Place **chocked blocks** underneath wheels to prevent **rolling**, while parked, if disconnected from towing vehicle.
- Inflate tires to correct pressure, inspect tires for cuts, and excessive wear. See Table 10 (Tire Wear Troubleshooting).
- When towing of the mixer is required, place the drum in the up position (mouth facing upwards).

- **ALWAYS** make sure that the fuel valve lever is in the **OFF** position (gasoline models only).
- Check wheel mounting lug nuts with a torque wrench. Torque wheel lug nuts as described in the maintenance section of this manual.
- Check tightness of U-clamp nuts, torque suspension hardware as referenced in the maintenance section of this manual.
- Avoid sudden stops and starts. This can cause skidding, or jackknifing. Smooth, gradual starts and stops will improve gas mileage.
- Avoid sharp turns to prevent rolling.

CAUTION

If the mixer tow bar is deformed or damaged replace entire tow bar. **NEVER** tow the mixer with a defective tow bar. There exists the possibility of the trailer separating from the **towing vehicle**.

TOW BAR TO VEHICLE (COUPLER ONLY)

1. Check the vehicle hitch ball, and mixer's coupler for signs of wear or damage. Replace any parts that are worn or damaged before towing.
2. Use only a 2-inch ball diameter (towing vehicle), this will match the mixer's 2-inch coupler. Use of any other ball diameter will create an extremely dangerous condition which can result in separation of the coupler and ball or ball failure.
3. After tow bar has been connected to mixer (see next page), attach mixer's coupler to the hitch ball on the towing vehicle securely and make sure the lock lever is in the down position (locked).

MIXER TOW BAR VEHICLE (PINTLE AND LOOP)

1. Make sure the bumper on the towing vehicle is equipped to handle either a pintle or loop type tow bar configuration.
2. After tow bar has been connected to mixer (see next page), secure either type of tow bar to the towing vehicle, following state and county towing regulations
3. As a minimum, use a 1/2-inch bolt and nylock nut grade 5 when securing either tow bar to the towing vehicle.

SAFETY CHAIN CONNECTION

CAUTION

NEVER tow the mixer with the safety chain removed. The safety chain is intended to prevent complete separation of the mixer from the towing vehicle in the event of a tow bar failure.

TOW BAR TO MIXER CONNECTION

1. Insert the tow bar through the round opening at the bottom of the mixer stand (Figure 7).

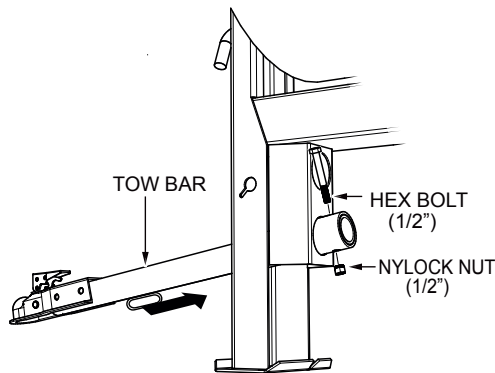

Figure 7. Inserting Tow Bar

2. Align the hole on the tow bar with the hole on the mixer frame (Figure 7), and insert 1/2-inch bolt through tow bar and frame. Secure tow bar to frame with 1/2-inch nylock nut. Tighten to 40 ft.-lbs.
3. Route the safety chain through the holes just above the tow bar, located on each side of the mixer stand.

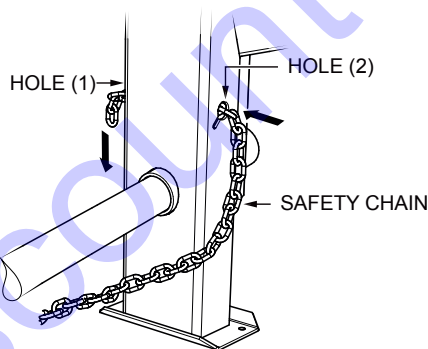

Figure 8. Attaching Safety Chains to Mixer Stand

4. Loop (cross) the safety chain (Figure 9) and place under the tow bar. Secure the loop with the safety chain connector link.

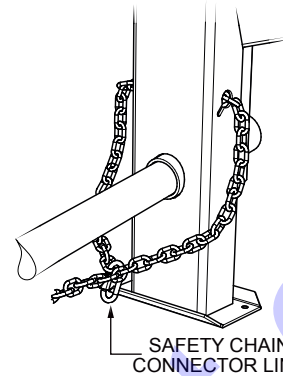

Figure 9. Crossing The Safety Chain

5. Extend the safety chain along the length of the tow bar (Figure 10), looping it through the tow bar's connector link. Remove any excess chain slack.

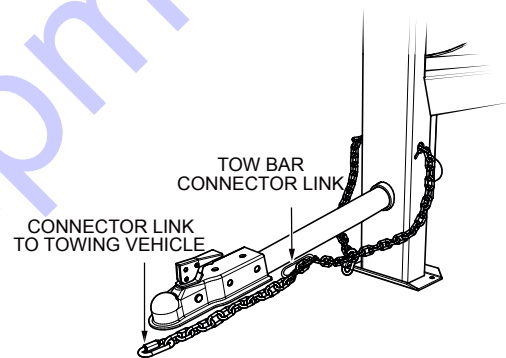

Figure 10. Extending Safety Chain

6. Connect the free end of (connector link) the safety chain to the towing vehicle (Figure 10). Remember it is critical that the length of the chain be properly adjusted, to prevent the draw bar and the front of the mixer stand from dropping to the the ground (contact) in the event the draw bar becomes disconnected from the towing vehicle.

CAUTION

Use a lifting device to lift tow bar onto vehicle coupler. If lifting device is not available, have two persons of similar height lift the tow bar. When lifting, do not attempt to lift by bending forward. Bend hips and knees to squat down to your load, keep it close to your body, and straighten your legs to lift.

BEFORE STARTING

CAUTION

NEVER disable or disconnect the **start/stop switch**. It is provided for operator safety. Injury may result if it is disabled, disconnected or improperly maintained.

1. Read all safety instructions at the beginning of manual.
2. Clean the unit, removing dirt and dust, particularly the engine cooling air inlet, carburetor and air cleaner.
3. Check the air filter for dirt and dust. If air filter is dirty, replace air filter with a new one as required.
4. Check carburetor for external dirt and dust. Clean with dry compressed air.
5. Check fastening nuts and bolts for tightness.

CAUTION



ALWAYS wear approved eye and hearing protection while operating the mixer.

CAUTION



NEVER place hands or feet inside the engine guard cover while the engine is running. **ALWAYS** shut the engine down before performing any kind of maintenance service on the mixer.

ENGINE OIL CHECK

1. To check the engine oil level, place the unit on secure level ground with the engine stopped.
2. Remove the filler dipstick from the engine oil filler hole (Figure 11) and wipe it clean.

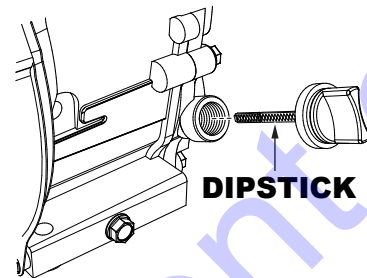

Figure 11. Engine Oil Dipstick (Removal)

3. Insert and remove the dipstick without screwing it into the filler neck. Check the oil level shown on the dipstick.
4. If the oil level is low (Figure 12), fill to the edge of the oil filler hole with the recommended oil type (Table 7). Maximum oil capacity is 2.33 pints (1.09 liters).

NOTICE

Reference engine manufacturer's manual for specific servicing instructions.

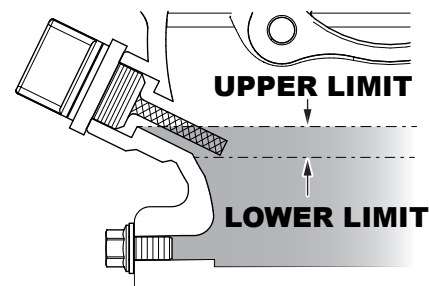

Figure 12. Engine Oil Dipstick (Oil Level)

Table 7. Engine Oil Type

Season	Temperature	Oil Type
Summer	25°C or Higher	SAE 10W-30
Spring/Fall	25°C ~ 10°C	SAE 10W-30/20
Winter	0°C or Lower	SAE 10W-10

FUEL CHECK

! DANGER



If your mixer has a gasoline engine, determine if the engine fuel is low. If fuel is low, remove the fuel filler cap and fill it with **unleaded** gasoline. Motor fuels are **highly flammable** and can be dangerous if mishandled. **DO NOT** smoke while refueling. **DO NOT** attempt to refuel the mixer if the engine is **hot** or **running**.

1. Remove the gasoline cap located on top of fuel tank.
2. Visually inspect to see if fuel level is low. If fuel is low, replenish with unleaded fuel.

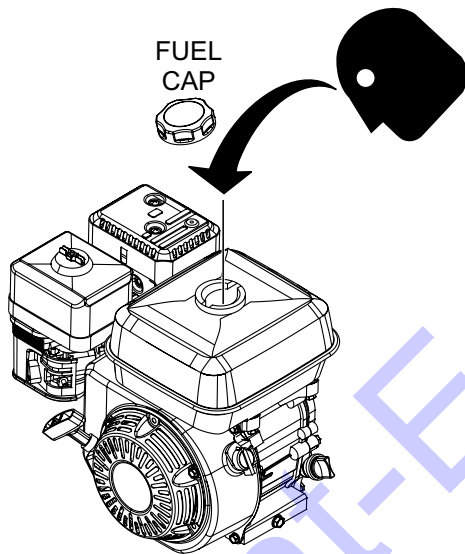

Figure 13. Engine Oil Dipstick (Oil Level)

3. When refueling, be sure to use a strainer for filtration. **DO NOT** top-off fuel. Wipe up any spilled fuel immediately.

TIRES

Check for **worn** or **defective** tires (Figure 14). Replace any defective or worn tires immediately.

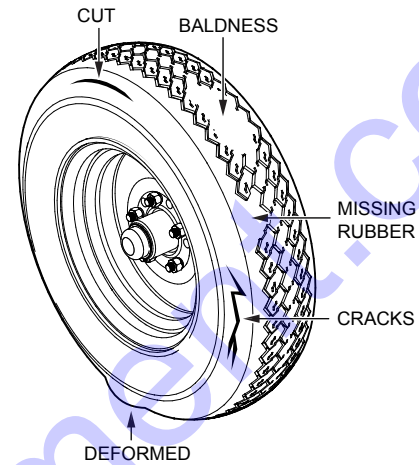

Figure 14. Tire Wear

V-BELT CHECK

Visually examine the V-belt (Figure 15) and determine if it is full of tiny cracks, frayed, has pieces of rubber missing, is peeling or otherwise damaged.

Also, examine the belt and determine if it is **oil soaked** or "**glazed**" (hard shiny appearance on the sides of the belt). Either of these two conditions can cause the belt to run hot, which can weaken it and increase the danger of it breaking.

If the V-belt exhibits any of the above wear conditions replace the V-belt immediately.

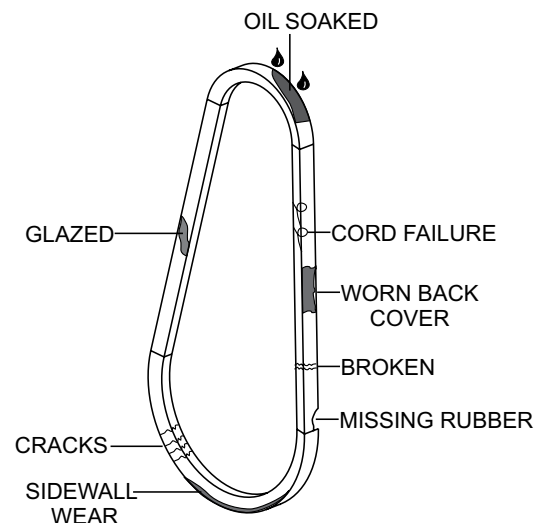

Figure 15. V-Belt Inspection

START-UP

This section is intended to assist the operator with the initial start-up of the unit. It is extremely important that this section be read carefully before attempting to use the mixer in the field. **DO NOT** use your mixer until this section is thoroughly understood.



WARNING

Failure to understand the operation of the mixer could result in severe damage to the mixer or personal injury. Reference Figure 3 and Figure 4 for the location of any components referenced in this manual.

CAUTION



NEVER operate the mixer in a confined area or enclosed area structure that does not provide ample free flow of air.

STARTING THE MIXER (GASOLINE ENGINE)

The following steps outline the procedure for starting the engine.

1. Place the fuel shut-off lever (Figure 16) in the **ON** position.

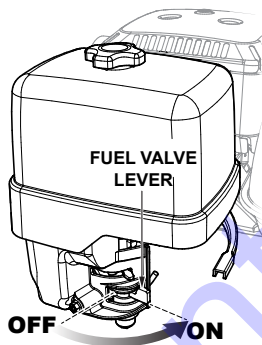

Figure 16. Fuel Shut-Off Lever

2. To start a cold engine, move the choke lever (Figure 17) to the **CLOSED** position.

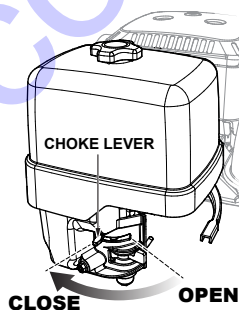

Figure 17. Choke Lever

3. Move the throttle lever (Figure 18) away from the slow position, about 1/3 of the way toward the fast position.

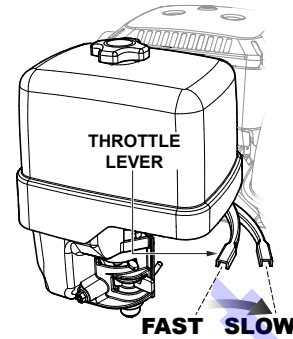

Figure 18. Throttle Lever

4. Turn the engine switch (Figure 19) to the ON position.

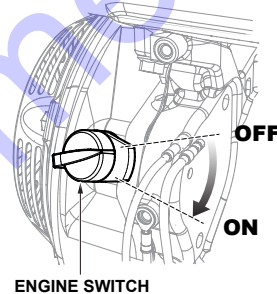

Figure 19. Engine On/Off Switch

5. Located at the rear of the mixer frame is the main **start/stop** button (Figure 20). Pull this button outward to start the engine.

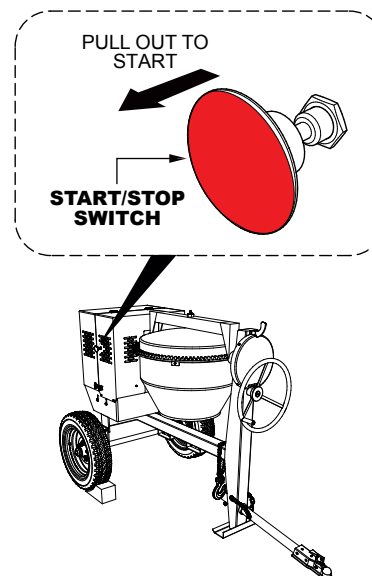
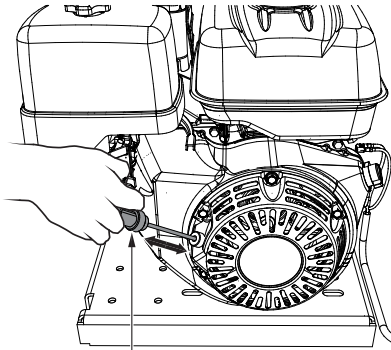

Figure 20. Engine Start/Stop Button

- Pull the **starter grip** (Figure 21) lightly until you feel resistance, then pull briskly. Return the starter grip gently.



STARTER GRIP

Figure 21. Starter Grip

STARTING THE MIXER (ELECTRIC MOTOR)

The following steps outline the procedure for starting the electric motor.

- Using an adequate size extension cord (Table 8), connect one end of the extension cord to the plug on the electric motor, connect the other end to the power source. Make sure the motor is configured for the proper operating voltage.

Table 8. Recommended Extension Cord Size

Electric Motor	Input Voltage	50 ft. (15.24 m)	75 ft. (22.86 m)	100 ft. (30.48 m)	200 ft. (60.96 m)
1.5 HP	120 VAC	No. 12	No. 10	No. 8	No. 6
	240 VAC	No. 14	No. 12	No. 12	No. 8

CAUTION: Equipment damage can result from low voltage

NOTICE

Extensions cords must be rated "Heavy Duty" or "Extra Heavy Duty" and must be a continuous length.

- To start the electric motor, move the **ON/OFF** switch to the ON position (Figure 22).

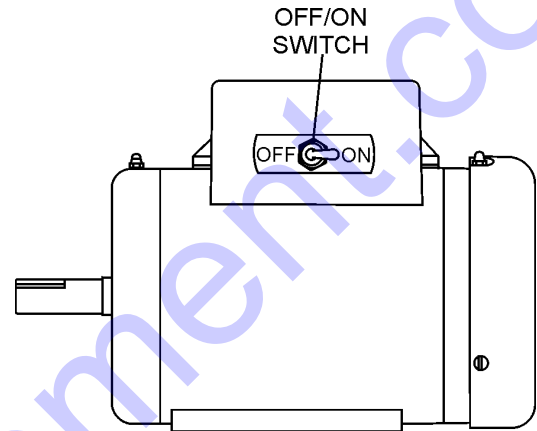

Figure 22. Electric Motor ON/OFF Switch

MIXING

1. To position the tub, make sure the mixer is placed on firm level ground, then pull up on the dump latch (Figure 23) and turn the hand wheel until the tub is at the desired position. Once the tub is at the desired position, pull down on the dump latch to lock the tub in position.

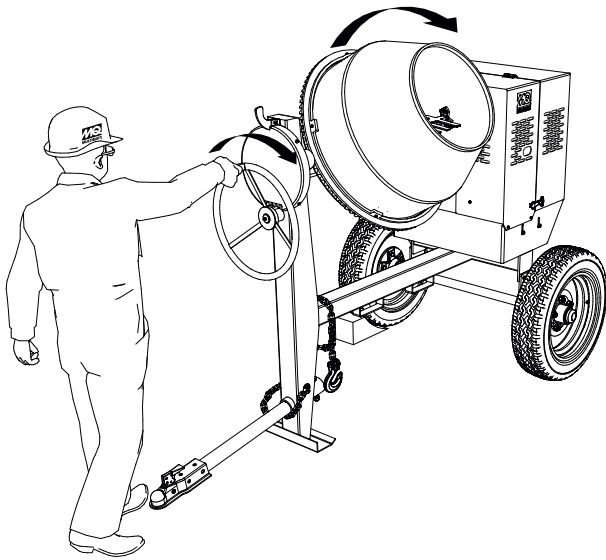

Figure 23. Mixing Drum Positioning

CAUTION

NEVER stand in front or behind the mixing drum while it is being placed in the dump position. Stay clear of the mixing drum while it is being positioned.

2. As the drum rotates, use a shovel (Figure 24) to place the cement mix inside the drum, add water as required. Be careful to only place the tip of the shovel inside the drum.

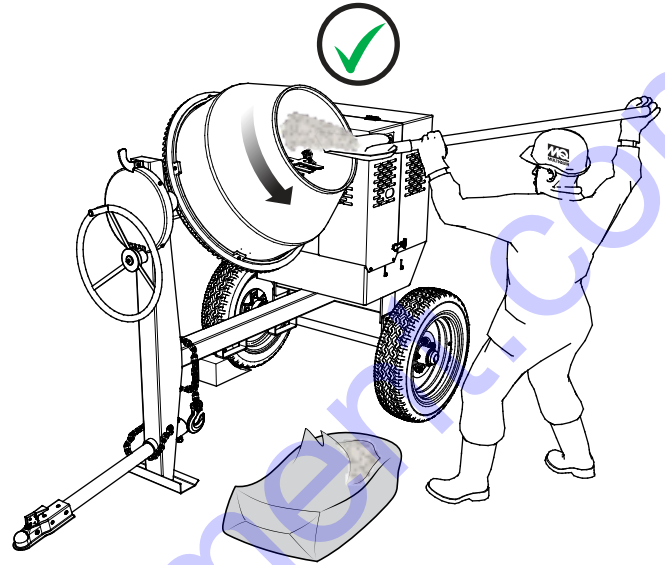

Figure 24. Filling Mixing Drum (CORRECT)

3. Placing the shovel all the way inside the drum (Figure 25) will cause the shovel to strike the blades. This condition will make the shovel rotate, and could cause injury to personnel. **NEVER** place hands inside the mixing drum while it is rotating.

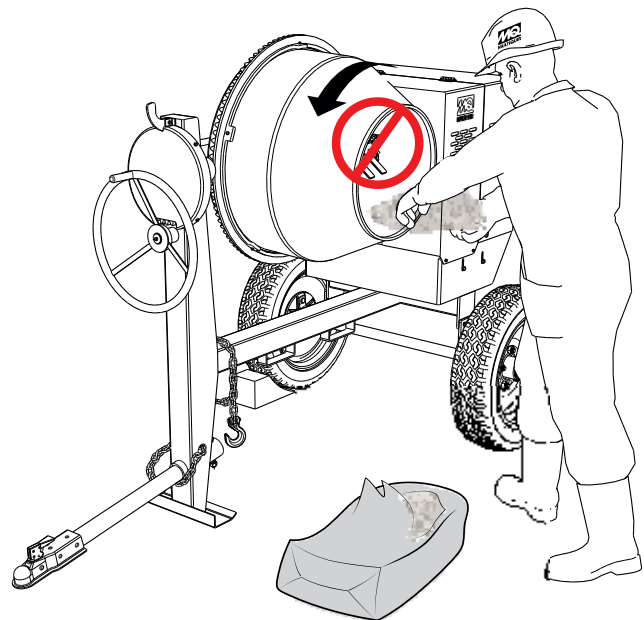

Figure 25. Filling Mixing Drum (WRONG)

OPERATION

STOPPING THE MIXER (GASOLINE ENGINE)

1. Place the throttle lever (Figure 26) in the slow (idle) position, and let the engine idle 3~5 minutes.

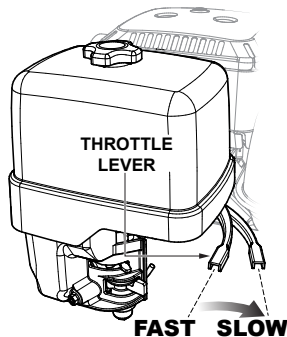

Figure 26. Throttle Lever (Idle)

2. Push the engine **start/stop** switch (Figure 27) inward to stop the engine.

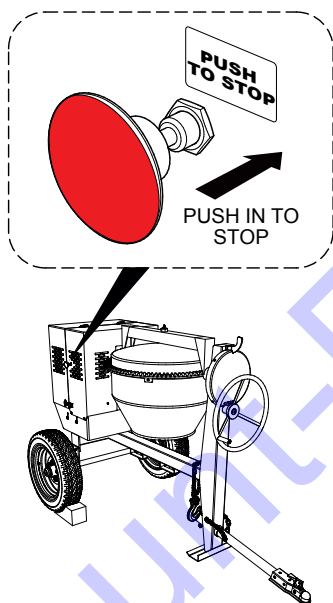

Figure 27. Start/Stop Button (Stop Position)

3. Place fuel shut-off lever (Figure 28) in the **OFF** position.

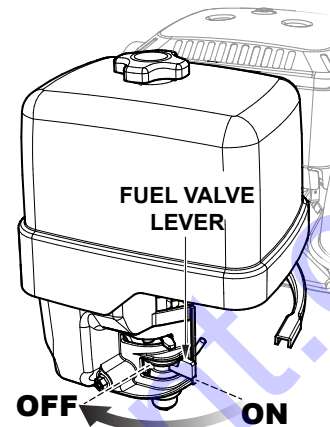

Figure 28. Fuel Shut-Off Lever (OFF)

STOPPING THE MIXER (ELECTRIC MOTOR)

1. To stop the electric motor, move the **ON/OFF** switch to the **OFF** position (Figure 29).

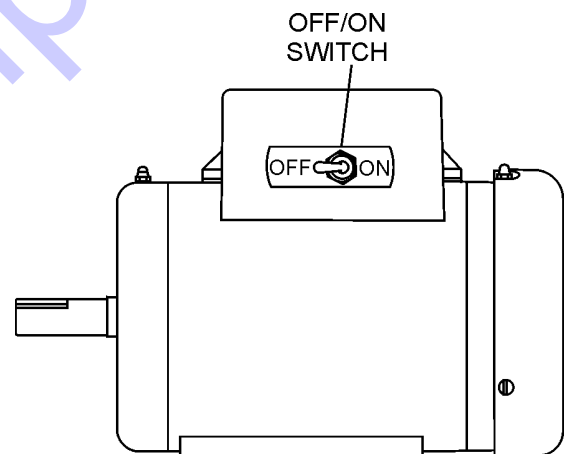

Figure 29. Electric Motor OFF/STOP Switch

2. Remove extension cord from electric motor plug.

MAINTENANCE (ENGINE)

Use Table 9 as a general maintenance guideline when servicing your engine. For more detail engine maintenance information, refer to the engine owner's manual supplied with your engine.

Table 9. Engine Maintenance Schedule							
DESCRIPTION (3)	OPERATION	BEFORE	FIRST MONTH OR 10 HRS.	EVERY 3 MONTHS OR 25 HRS.	EVERY 6 MONTHS OR 50 HRS.	EVERY YEAR OR 100 HRS.	EVERY 2 YEARS OR 200 HRS.
Engine Oil	Check	X					
	Change		X				
Air Cleaner	Check	X					
	Change			X (1)			
All Nuts and Bolts	Re-tighten if necessary	X					
Spark Plugs	Check/Clean				X		
	Replace						X
Cooling Fins	Check				X		
Spark Arrester	Clean					X	
Fuel Tank	Clean					X	
Fuel Filter	Check					X	
Idle Speed	Check/ Adjust					X (2)	
Valve Clearance	Check/ Adjust						X (2)
Fuel Lines	Check	Every 2 years (replace if necessary) (2)					

(1) Service more frequently when used in **DUSTY** areas.

(2) These items should be serviced by your service dealer, unless you have the proper tools and are mechanically proficient. Refer to the HONDA Shop Manual for service procedures.

(3) For commercial use, log hours of operation to determine proper maintenance intervals.

MAINTENANCE (ENGINE)

MAINTENANCE

Perform the scheduled maintenance procedures as defined by Table 9 and below:

DAILY

AIR CLEANER/ FASTENERS

Thoroughly remove dirt and oil from the engine and control area. Clean or replace the air cleaner elements as necessary. Check and retighten all fasteners as necessary.

WIRING

Inspect the entire mixer for bad or worn electrical wiring or connections. If any wiring or connections are exposed (insulation missing) replace wiring immediately.

PIPING AND HOSE CONNECTION

Inspect all piping, oil hose, hydraulic hose and fuel hose connections for wear and tightness. Tighten all hose clamps and check for leaks. If any hose lines are defective replace them immediately.

WEEKLY

FUEL STRAINER (IF EQUIPPED)

1. Thoroughly clean the area around the fuel cap.
2. Remove the fuel cap from the fuel tank.
3. Next, remove, inspect and clean the fuel strainer (Figure 30) with solvent.

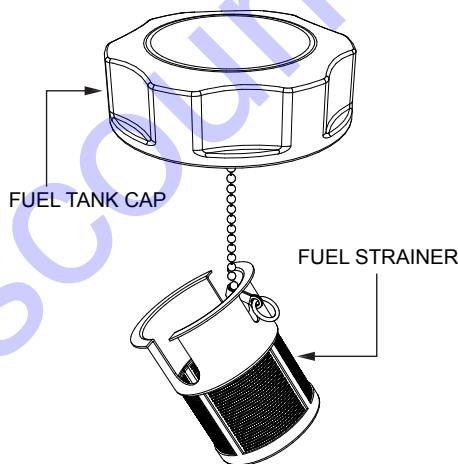

Figure 30. Fuel Strainer

SPARK PLUG

1. Remove and clean the spark plug (Figure 31), then adjust the spark gap to 0.024 ~0.028 inch (0.6~0.7 mm). This unit has electronic ignition, which requires no adjustments.

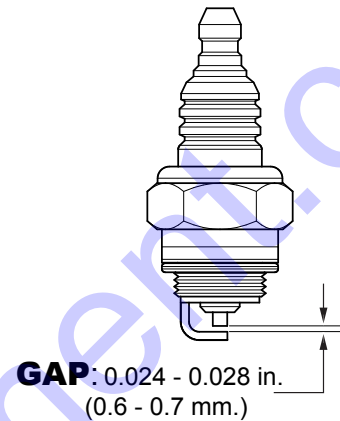

Figure 31. Spark Plug Gap

ENGINE OIL

1. Drain the engine oil when the oil is warm as shown in Figure 32.
2. Unscrew the oil filler dipstick from its holder.
3. Next, remove oil drain bolt and sealing washer and allow the oil to drain into a suitable container.
4. Replace engine oil with recommended type oil as listed in Table 7. For engine oil capacity, see Table 3 (Engine Specifications). **DO NOT** overfill.
5. Install drain bolt with sealing washer and tighten securely.

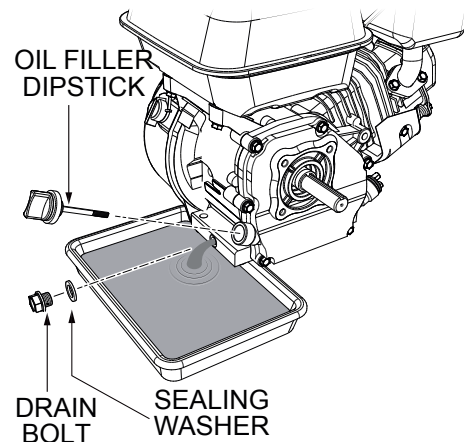

Figure 32. Draining Engine Oil

MAINTENANCE (ENGINE)

ENGINE AIR CLEANER (DUAL ELEMENT)

1. Remove the air cleaner cover and foam filter element as shown in Figure 33.
2. Tap the paper filter element (Figure 33) several times on a hard surface to remove dirt, or blow compressed air [not exceeding 30 psi (207 kPa, 2.1 kgf/cm²)] through the filter element from the air cleaner case side. **NEVER** brush off dirt. Brushing will force dirt into the fibers. Replace the paper filter element if it is excessively dirty.
3. Clean foam element in warm, soapy water or nonflammable solvent (Figure 34). Rinse and dry thoroughly.
4. Next, dip the element in clean engine oil and completely squeeze out the excess oil from the element before installing. The engine will smoke if too much oil is left in the foam.

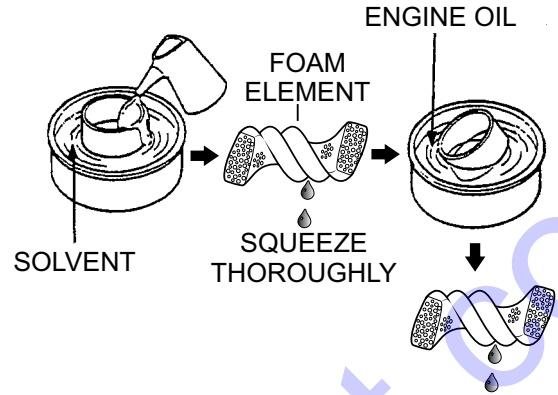

Figure 34. Cleaning Foam Element

5. Reassemble the air cleaner, and tighten the wing nut securely.

SPARK ARRESTER CLEANING

Clean the spark arrester every 6 months or 100 hours.

1. Remove the 4 mm screw (3) from the exhaust deflector (Figure 35), then remove the deflector.

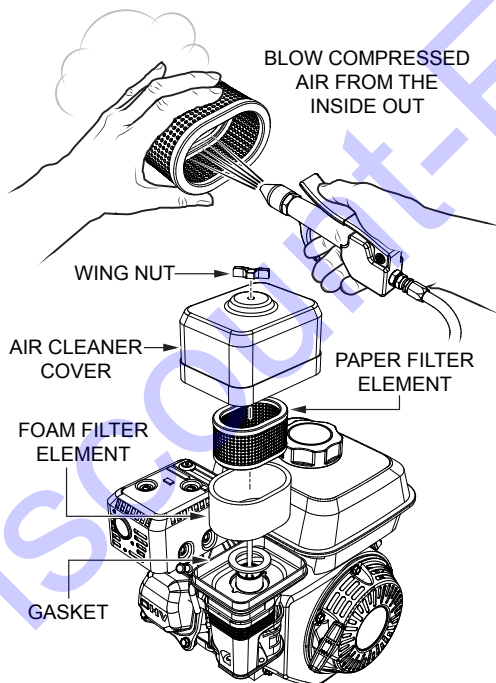
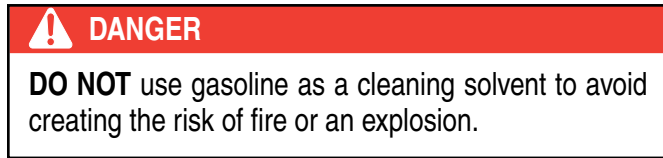

Figure 33. Engine Air Cleaner (Dual Element)

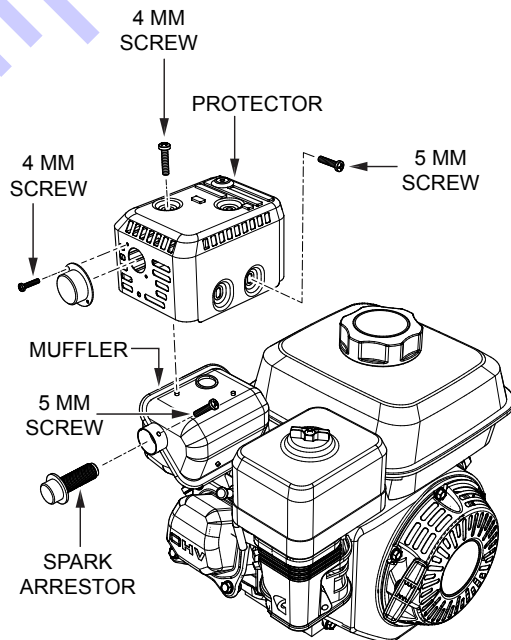

Figure 35. Spark Arrester

2. Remove the 5 mm screw (4) from the muffler protector, then remove the muffler protector.

MAINTENANCE (MIXER)

3. Carefully remove carbon deposits from the spark arrester screen (Figure 36) with a wire brush

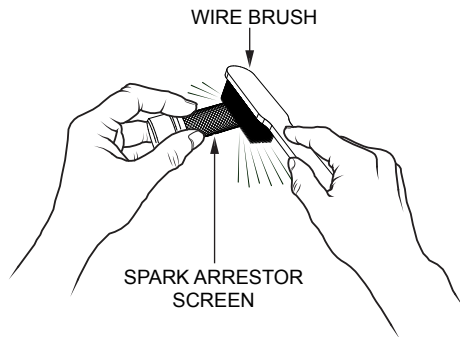

Figure 36. Cleaning The Spark Arrester

4. If the spark arrester is damaged and has breaks or holes, replace with a new one.
5. Reinstall the spark arrester and muffler protector in reverse order of disassembly.

BALL SOCKET AND CLAMP FACE

1. If the towing vehicle is equipped with a ball socket, smear socket periodically with multi-purpose grease. This will keep the ball socket well lubricated.
2. Periodically oil **pivot points** and **clamp face** surfaces of coupler with SAE 30 WT. motor oil.
3. When parking or storing your mixer, keep the coupler off the ground so dirt will not build up in the ball socket.

GREASE FITTINGS (ZERK) - MIXER

1. There are **four** grease (Figure 37) fittings that will require lubrication. Lubricate these fittings **once a week**. Use lithium base grease, grade NO.1.

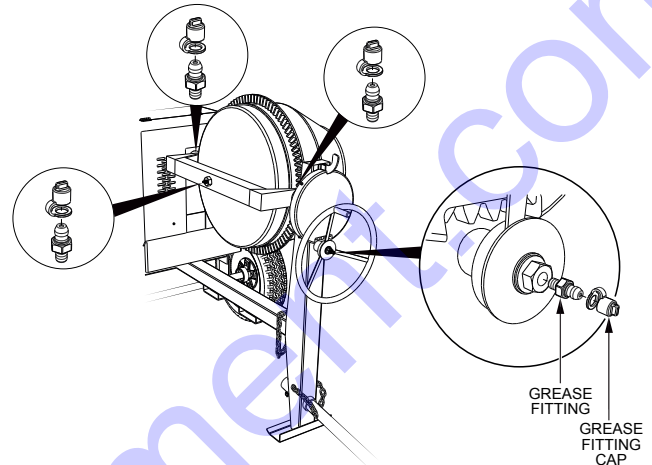

Figure 37. Grease Fittings (Mixer)

GREASE FITTINGS (ZERK) - ELECTRIC MOTOR

1. There are **two** grease (Figure 38) fittings at each end of the electric motor that will require lubrication. Lubricate these fittings about **every 16 months**.

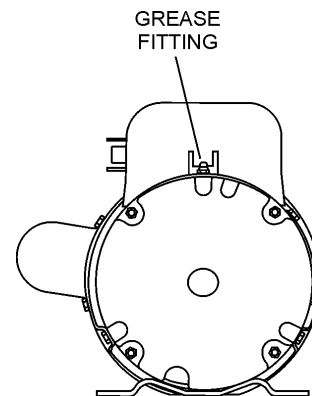

Figure 38. Grease Fittings (Electric Motor)

2. Use Poleyrex EM (Exxon Mobil) or equivalent lubricant. Clean grease fitting, apply grease gun to fitting (1/2 shot). Remember too much grease or injecting grease too quickly can cause premature bearing failure. Slowly apply the recommended amount of grease, taking a minute or so to apply.

MAINTENANCE (MIXER)

WHEEL BEARINGS

1. After **every 3 months** of operation, remove the hub dust cap and inspect the wheel bearings (Figure 39). Once a year, or when required, disassemble the wheel hubs remove the old grease and repack the bearings forcing grease between rollers, cone and cage with a good grade of high speed wheel bearing grease (never use grease heavier than 265 A.S.T.M. penetration (“No. 2.”).

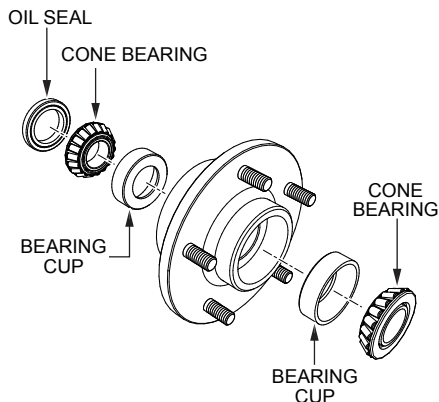

Figure 39. Wheel Hub and Bearings

2. Fill the wheel hub (Figure 39) with grease to the inside diameter of the outer races and also fill the hub grease cap. Reassemble the hub and mount the wheel. Then tighten the adjusting nut, at the same time turn the wheel in both directions, until there is a slight bind to be sure all the bearing surfaces are in contact.

Then back-off the adjusting nut 1/6 to 1/4 turn or to the nearest locking hole or sufficiently to allow the wheel to rotate freely within limits of .001” to .010” end play. Lock the nut at this position. Install the cotter pin and dust cap, and tighten all hardware.

MIXER CLEANING

It is important that the drum interior is free of dried material. Obstructions can cause the paddle blades to lock against the drum.

1. For gasoline models, push the “**Engine Stop**” button inward to the **OFF** position to stop the engine. For electric models place the ON/OFF switch in the **OFF** position.
2. If mixer is equipped with a gasoline engine, **ALWAYS disconnect the spark plug wire** before cleaning the inside of the drum.

3. If mixer is equipped with an electric motor **remove power cord from AC power source..**
4. Place “**DO NOT Operate**” tag on mixer.
5. At the end of each day’s operation, place mixer drum in an upright position and spray inside of tub immediately with water to prevent lumps of dried mortar or plaster from forming and contamination of future batches.
6. **DO NOT** allow a buildup of materials to form on the blades or anywhere inside the drum.
7. Rotate mixer to **dump** position and remove debris.
8. **Thoroughly clean** the entire mixer, wheels, cabinet and frame.
9. **NEVER!** pour or spray water over the engine or electric motor (Figure 40).

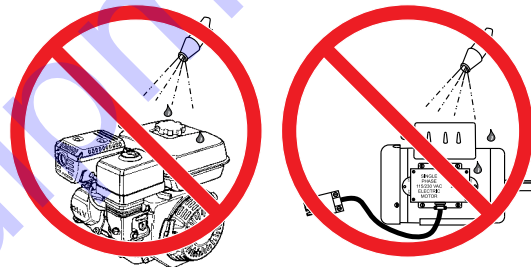

Figure 40. No Spraying of Water

10. When cleaning of the entire mixer is done, return mixing drum to an upright position.

TIRES/WHEELS/LUG NUTS

Tires and wheels are a very important and critical components of the trailer. When specifying or replacing the trailer wheels, it is important the wheels, tires and axle are properly matched.

WARNING



DO NOT attempt to repair or modify a wheel.
DO NOT install an inter-tube to correct a leak through the rim. If the rim is cracked, the air pressure in the inter-tube may cause pieces of the rim to explode (break-off) with great force and can cause serious eye or bodily injury.

MAINTENANCE (MIXER)

Tires Wear/Inflation







Tire inflation pressure is the most important factor in tire life. Pressure should be checked cold before operation. **DO NOT** bleed air from tires when they are hot. Check inflation pressure weekly during use to insure the maximum tire life and tread wear.

WARNING



ALWAYS wear safety glasses when removing or installing force fitted parts. Failure to comply may result in serious injury.

Table 10 (Tire Wear Troubleshooting) will help pinpoint the causes and solutions of tire wear problems.

Table 10. Tire Wear Troubleshooting			
Wear Pattern		Cause	Solution
	Center Wear	Over Inflation	Adjust pressure to particular load per tire manufacturer
	Edge Wear	Under Inflation	Adjust pressure to particular load per tire manufacturer.
	Side Wear	Loss of chamber or overloading	Make sure load does not exceed axle rating. Align wheels.
	Toe Wear	Incorrect toe-in	Align wheels.
	Cupping	Out of balance	Check bearing adjustment and balance tires.
	Flat Spots	Wheel lockup and tire skidding	Avoid sudden stops when possible and adjust brakes.

SUSPENSION

The spring suspension and associated components (Figure 41) should be visually inspected every 6,000 miles for signs of excessive wear, elongation of bolt holes and loosening of mounting bracket. Replace any damaged suspension component immediately.

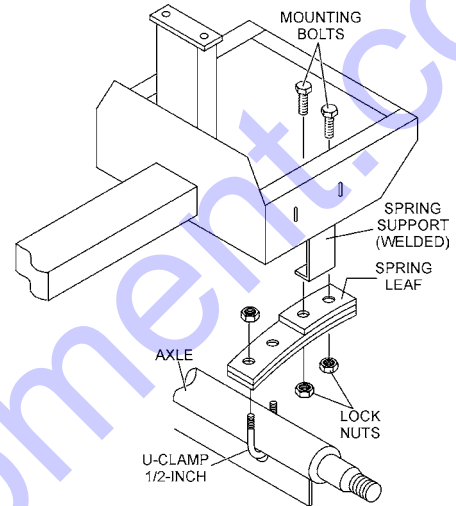

Figure 41. Suspension Components

LUG NUT TORQUE REQUIREMENTS

It is extremely important to apply and maintain proper wheel mounting torque. Be sure to use only the fasteners matched to the cone angle of the wheel. Proper procedure for attachment of the wheels is as follows:

1. Start all wheel lug nuts by hand.
2. Torque all lug nuts in sequence. See Figure 42. **DO NOT** torque the wheel lug nuts all the way down. Tighten (torque) each lug nut in three separate passes as defined by Table 11.

NOTICE

NEVER use an pneumatic air gun to tighten wheel lug nuts.

MAINTENANCE (MIXER)

3. After first road use, retorque all lug nuts in sequence. Check all wheel lug nuts periodically.

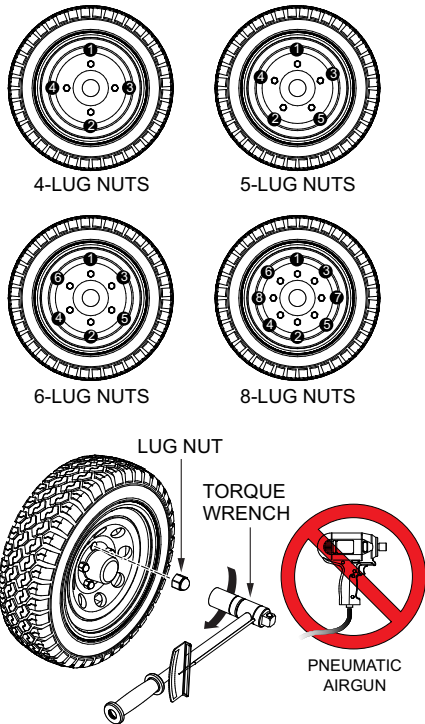

Figure 42. Wheel Lug Nuts Tightening Sequence

Table 11. Tire Torque Requirements

Wheel Size	First Pass FT-LBS	Second Pass FT-LBS	Third Pass FT-LBS
12"	20-25	35-40	50-65
13"	20-25	35-40	50-65
14"	20-25	50-60	90-120
15"	20-25	50-60	90-120
16"	20-25	50-60	90-120

MIXER STORAGE

For storage of the mixer for over 30 days, the following is recommended:

- Drain the fuel tank completely, or add STA-BIL to the fuel.
- Run the engine until the gasoline in the carburetor is completely consumed.
- Completely drain the oil from the crankcase and refill with fresh oil.
- Clean the entire mixer and engine compartment.
- Place the mixing drum in the down position (mouth facing downward).
- Clean all external parts of the mixer with a cloth.
- Cover the mixer and place it in a clean dry area, that is protected from harsh elements.

TROUBLESHOOTING (MIXER)

Troubleshooting (Mixer)		
Symptom	Possible Problem	Solution
Drum rotates rough.	Defective ring gear?	Check that the ring gear and bearings are not worn . Replace as necessary.
	Defective pinion gear?	Check that the pinion gear and bearings are not worn . Replace as necessary.
	Worn V-belt?	Replace V-belt.
	Loose pulley?	Tighten or replace pulley.
Drum does not rotate at all.	Incorrect or no voltage being supplied to electric motor?	Check that the electric motor has the correct supply voltage.
	Power to electric motor?	Inspect power source and extension cord. Push reset button on electric motor. Make sure correct voltage is being supplied to motor.
	Fuel?	Check level of fuel in fuel tank. Add fuel if necessary. Make sure fuel is being supplied to the engine. Check to ensure that the fuel filter is not clogged.
	Broken V-belt?	Replace V-belt.
	Defective ring or pinion gears?	Check that the gears and bearings are not broken. Replace as necessary.
	Defective electric motor?	Replace electric motor.

Troubleshooting (Electric Motor)		
Symptom	Possible Cause	Solution
Electric motor will not start.	Is there power?	Check power source. Check reset button.
	Is power cable plugged in?	Plug in power cable.
	Is ON/OFF switch placed in ON position?	Place ON/OFF switch in ON position.
	Defective electric motor ON/OFF switch?	Replace switch.
	Defective motor windings?	Repair windings or replace windings.
	Defective extension cord?	Replace extension cord.
Electric motor continuously stops.	Reset button OK?	Check power source.
Electric motor RPM's too low.	Low voltage?	Check input voltage.
Electric motor RPM's too high.	High voltage?	Check input voltage.

TROUBLESHOOTING (ENGINE)

Troubleshooting (Engine)		
Symptom	Possible Problem	Solution
Difficult to start, fuel is available, but no spark at spark plug.	Spark plug bridging?	Check gap, insulation or replace spark plug.
	Carbon deposit on spark plug?	Clean or replace spark plug.
	Short circuit due to deficient spark plug insulation?	Check spark plug insulation, replace if worn.
	Improper spark plug gap?	Set to proper gap.
	Spark plug is red?	Check transistor ignition unit.
	Spark plug is bluish white?	If insufficient compression, repair or replace engine. If injected air leaking, correct leak. If carburetor jets clogged, clean carburetor.
	No spark present at tip of spark plug?	Check transistor ignition unit is broken, and replace defective unit. Check if voltage cord is cracked or broken and replace. Check if spark plug is fouled. Replace if fouled.
	No oil?	Add oil as required.
	Oil pressure alarm lamp blinks upon starting? (if applicable)	Check automatic shutdown circuit, "oil sensor". (if applicable)
Difficult to start, fuel is available, and spark is present at the spark plug.	ON/OFF switch is shorted?	Check switch wiring, replace switch.
	Ignition coil defective?	Replace ignition coil.
	Improper spark gap, points dirty?	Set correct spark gap and clean points.
	Condenser insulation worn or short circuiting?	Replace condenser.
	Spark plug wire broken or short circuiting?	Replace defective spark plug wiring.
Difficult to start, fuel is available, spark is present and compression is normal.	Wrong fuel type?	Flush fuel system, replace with correct type of fuel.
	Water or dust in fuel system?	Flush fuel system.
	Air cleaner dirty?	Clean or replace air cleaner.
	Choke open?	Close choke.
Difficult to start, fuel is available, spark is present and compression is low.	Suction/exhaust valve stuck or protruded?	Reseat valves.
	Piston ring and/or cylinder worn?	Replace piston rings and/or piston.
	Cylinder head and/or spark plug not tightened properly?	Torque cylinder head bolts and spark plug.
	Head gasket and/or spark plug gasket damaged?	Replace head and spark plug gaskets.
No fuel present at carburetor.	No fuel in fuel tank?	Fill with correct type of fuel.
	Fuel cock does not open properly?	Apply lubricant to loosen fuel cock lever, replace if necessary.
	Fuel filter/lines clogged?	Replace fuel filter.
	Fuel tank cap breather hole clogged?	Clean or replace fuel tank cap.
	Air in fuel line?	Bleed fuel line.
Will not start, no power with key "ON". (if applicable)	ON/OFF device not in ON position?	Place ON/OFF device in ON position.

TROUBLESHOOTING (ENGINE)

Troubleshooting (Engine) - continued		
Symptom	Possible Problem	Solution
Weak in power, compression is proper and does not misfire.	Air cleaner dirty?	Clean or replace air cleaner.
	Improper level in carburetor?	Check float adjustment, rebuild carburetor.
	Defective spark plug?	Clean or replace spark plug.
	Improper spark plug?	Set to proper gap.
Weak in power, compression is proper but misfires.	Water in fuel system?	Flush fuel system and replace with correct type of fuel.
	Dirty spark plug?	Clean or replace spark plug.
	Ignition coil defective?	Replace ignition coil.
Engine overheats.	Spark plug heat value incorrect?	Replace with correct type of spark plug.
	Wrong type of fuel?	Replace with correct type of fuel.
	Cooling fins dirty?	Clean cooling fins.
	Intake air restricted?	Clear intake of dirt and debris. Replace air cleaner elements as necessary.
	Oil level too low or too high?	Adjust oil to proper level.
Rotational speed fluctuates.	Governor adjusted incorrectly?	Adjust governor.
	Governor spring defective?	Replace governor spring.
	Fuel flow restricted?	Check entire fuel system for leaks or clogs.
Recoil starter malfunctions. (if applicable)	Recoil mechanism clogged with dust and dirt?	Clean recoil assembly with soap and water.
	Spiral spring loose?	Replace spiral spring.
Burns too much fuel.	Over-accumulation of exhaust products?	Check and clean valves. Check muffler and replace if necessary.
	Wrong spark plug?	Replace spark plug with manufacturer's suggested type.
Exhaust color is continuously "white".	Lubricating oil is wrong viscosity?	Replace lubricating oil with correct viscosity.
	Worn rings?	Replace rings.
Exhaust color is continuously "black".	Air cleaner clogged?	Clean or replace air cleaner.
	Choke valve set to incorrect position?	Adjust choke valve to correct position.
	Carburetor defective, seal on carburetor broken?	Replace carburetor or seal.
	Poor carburetor adjustment, engine runs too rich?	Adjust carburetor.

EXPLANATION OF CODE IN REMARKS COLUMN

The following section explains the different symbols and remarks used in the Parts section of this manual. Use the help numbers found on the back page of the manual if there are any questions.

NOTICE

The contents and part numbers listed in the parts section are subject to change **without notice**. Multiquip does not guarantee the availability of the parts listed.

SAMPLE PARTS LIST

NO.	PART NO.	PART NAME	QTY.	REMARKS
1	12345	BOLT.....	1	INCLUDES ITEMS W/%
2%		WASHER, 1/4 IN.....		NOT SOLD SEPARATELY
2%	12347	WASHER, 3/8 IN....	1	MQ-45T ONLY
3	12348	HOSE	A/R	MAKE LOCALLY
4	12349	BEARING	1	S/N 2345B AND ABOVE

NO. Column

Unique Symbols — All items with same unique symbol

(@, #, +, %, or >) in the number column belong to the same assembly or kit, which is indicated by a note in the “Remarks” column.

Duplicate Item Numbers — Duplicate numbers indicate multiple part numbers, which are in effect for the same general item, such as different size saw blade guards in use or a part that has been updated on newer versions of the same machine.

NOTICE

When ordering a part that has more than one item number listed, check the remarks column for help in determining the proper part to order.

PART NO. Column

Numbers Used — Part numbers can be indicated by a number, a blank entry, or TBD.

TBD (To Be Determined) is generally used to show a part that has not been assigned a formal part number at the time of publication.

A blank entry generally indicates that the item is not sold separately or is not sold by Multiquip. Other entries will be clarified in the “Remarks” Column.

QTY. Column

Numbers Used — Item quantity can be indicated by a number, a blank entry, or A/R.

A/R (As Required) is generally used for hoses or other parts that are sold in bulk and cut to length.

A blank entry generally indicates that the item is not sold separately. Other entries will be clarified in the “Remarks” Column.

REMARKS Column

Some of the most common notes found in the “Remarks” Column are listed below. Other additional notes needed to describe the item can also be shown.

Assembly/Kit — All items on the parts list with the same unique symbol will be included when this item is purchased.

Indicated by:

“INCLUDES ITEMS W/(unique symbol)”

Serial Number Break — Used to list an effective serial number range where a particular part is used.

Indicated by:

“S/N XXXXX AND BELOW”

“S/N XXXX AND ABOVE”

“S/N XXXX TO S/N XXX”

Specific Model Number Use — Indicates that the part is used only with the specific model number or model number variant listed. It can also be used to show a part is NOT used on a specific model or model number variant.

Indicated by:

“XXXXX ONLY”

“NOT USED ON XXXX”

“Make/Obtain Locally” — Indicates that the part can be purchased at any hardware shop or made out of available items. Examples include battery cables, shims, and certain washers and nuts.

“Not Sold Separately” — Indicates that an item cannot be purchased as a separate item and is either part of an assembly/kit that can be purchased, or is not available for sale through Multiquip.

SUGGESTED SPARE PARTS

MC-94S/P CONCRETE MIXER 1 TO 4 UNITS WITH HONDA GX240 SERIES ENGINES

Qty.	P/N	Description
2	493399	V-BELT, GASOLINE B-55, 8.0 HP
2	512265	V-BELT, ELECT., MOTOR B-59, 1.5 HP
1	29173-001	STOP BUTTON W/GAS ENGINE
2	491010	LATCH SET
1	505390	EXPANSION PLUG
2	510956	SPINDLE BEARING CUP
2	510955	SPINDLE BEARING CONES
1	EM505472	SPACER, DRUM (STEEL ONLY)
2	EM914288	SEAL, AXLE
2	EM903012	BEARING CUP
2	EM903113	BEARING CONE
2	3469	DUST CAP, AXLE
3♣	17210ZE2515	ELEMENT, AIR CLEANER
3◇	17210ZE2822	ELEMENT, AIR CLEANER
3	9807956855	SPARK PLUG, DENSO
1♣	17620ZH7023	CAP, FUEL TANK
1◇	17620Z4H020	CAP, FUEL TANK
1	28462ZE2W11	ROPE, RECOIL

NOTICE

- ♣ HONDA GX240K1QA2
- ◇ HONDA GX240UT1QA2

NOTICE

Part numbers on this Suggested Spare Parts list may supersede/replace the part numbers shown in the following parts lists.

NAMEPLATE AND DECALS ASSY.

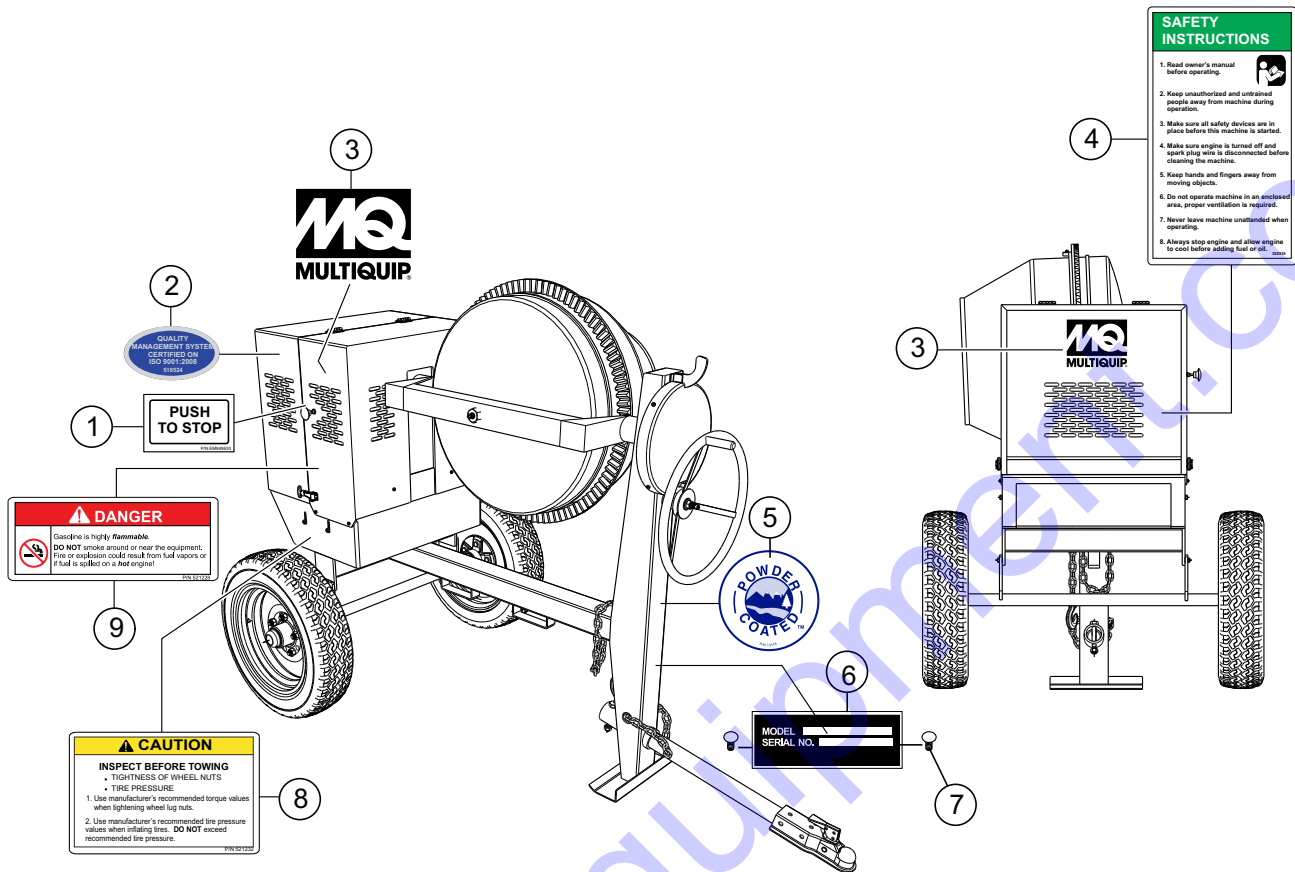

- SAFETY INSTRUCTIONS**
1. Read owner's manual before operating.
 2. Keep unauthorized and untrained people away from machine during operation.
 3. Make sure all safety devices are in place before this machine is started.
 4. Make sure engine is turned off and spark plug wire is disconnected before cleaning the machine.
 5. Keep hands and fingers away from moving objects.
 6. Do not operate machine in an enclosed area, proper ventilation is required.
 7. Never leave machine unattended when operating.
 8. Always stop engine and allow engine to cool before adding fuel or oil.

CAUTION

INSPECT BEFORE TOWING

- TIGHTNESS OF WHEEL NUTS
- TIRE PRESSURE

1. Use manufacturer's recommended torque values when tightening wheel lug nuts.
2. Use manufacturer's recommended tire pressure values when inflating tires. DO NOT exceed recommended tire pressure.

WARNING

To avoid injury, you MUST read and understand operator's manual before using this machine.

Keep safety pins, guards and blocks in place. Shut off engine or electric motor before placing hands in mixing drum.

Mixing pins can cut and crush. SHUT OFF engine or electric motor before placing hands in mixing drum.

This machine is to be operated by qualified personnel only. Ask for training as needed.

CAUTION

DRUM LOCK POSITIONING

SEE OPERATION MANUAL FOR PROPER DRUM LOCK POSITIONING

LEGEND

● REPRESENTS LOCK PIN

■ REPRESENTS DRUM STOP BLOCK

MIX TOW

CAUTION

INSPECT BEFORE TOWING

- TIGHTNESS OF WHEEL NUTS
- TIRE PRESSURE

1. Use manufacturer's recommended torque values when tightening wheel lug nuts.
2. Use manufacturer's recommended tire pressure values when inflating tires. DO NOT exceed recommended tire pressure.

NAMEPLATE AND DECALS ASSY.

<u>NO.</u>	<u>PART NO.</u>	<u>PART NAME</u>	<u>QTY.</u>	<u>REMARKS</u>
1	948630	DECAL, PUSH TO STOP	1	
2	518524	DECAL, ISO 9001:2000, EXPORT	1	
3	512910	MQ MULTQUIP LOGO	3	
4	520935	DECAL, SAFETY INSTRUCTIONS	1	
5	13118	DECAL, POWDER COATED	1	
6		NAMEPLATE	1CONTACT MQ PARTS DEPT.
7	491757	POP RIVET	2	
8	521232	DECAL, TOWING INSTRUCTIONS	2	
9	521228	DECAL, DANGER NO SMOKING	2	
10	521229	DECAL, WARNING READ MANUAL	2	
11	521231	DECAL, DRUM LOCK POSITION	1	

PLASTIC BARREL ASSY.

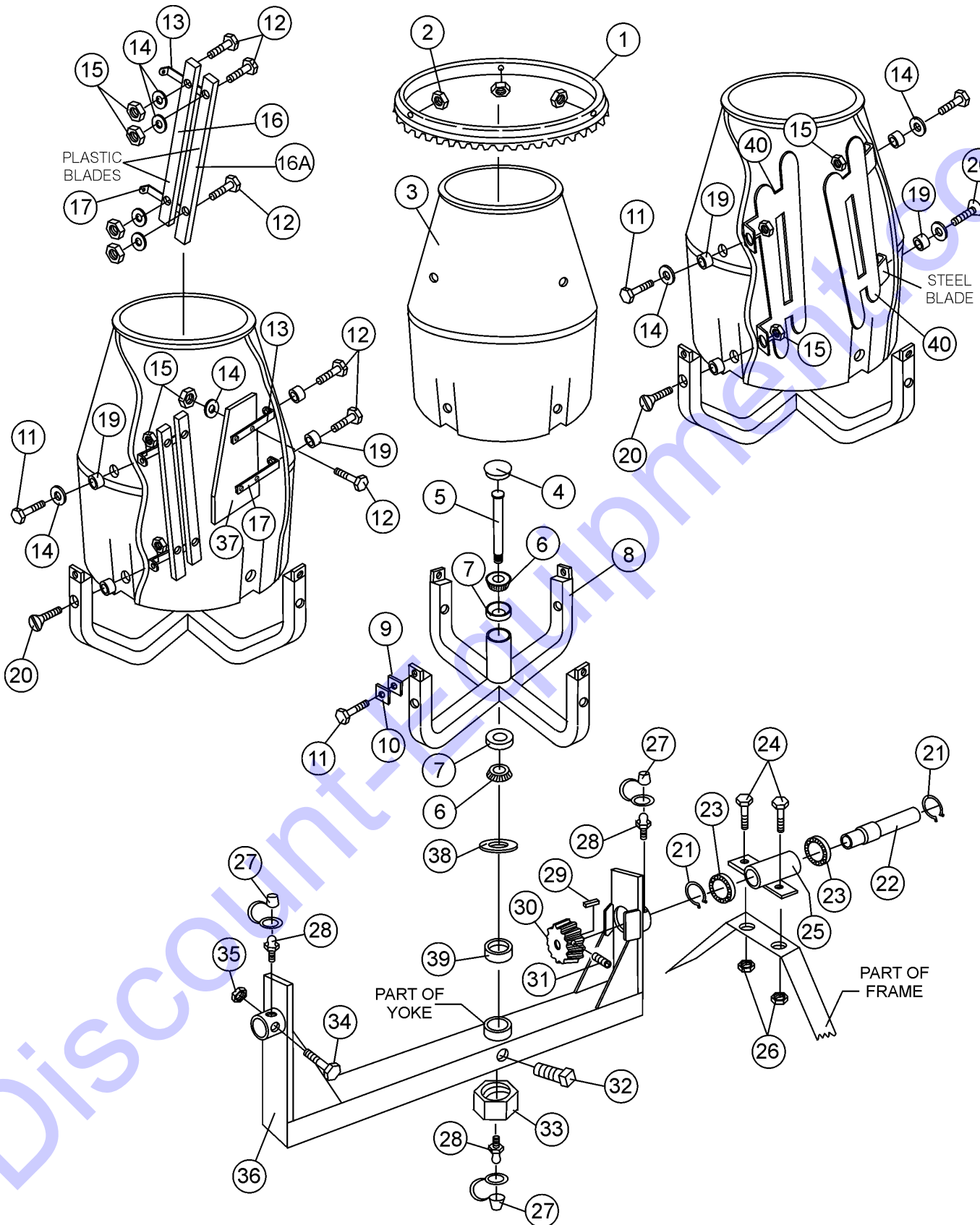

PLASTIC BARREL ASSY.

<u>NO.</u>	<u>PART NO.</u>	<u>PART NAME</u>	<u>QTY.</u>	<u>REMARK</u>
1	514061	RING GEAR	1	
2	EM969013	NUT, LOCK 3/8" NC	4	
3	508492	BARREL, PLASTIC 9 CU. FT.	1	
4	505390	PLUG, EXPANSION	1	
5	508491	KING PIN	1	
6	510955	SPINDLE BEARING CONE	2	
7	510956	SPINDLE BEARING CUP	2	
8	514930	SUPPORT SPIDER	1	
9	511758	SHIM PLASTIC #14	AR	
10	511759	SHIM PLASTIC #16	AR	
11	EM963057	BOLT 3/8" NC 1-1/2" G5	4	
12	492378	BOLT 3/8" NC 1-3/4" G5	16	
13	507542	SUPPORT BRACKET, UPPER	4	
14	492598	WASHER, FLAT	16	
15	492583	NUT, HEX 3/8" NC	16	
16	508497	PLASTIC BLADE, VERT. LONG	2	
16A	508498	PLASTIC BLADE, VERT. SHORT	2	
17	507541	SUPPORT BRACKET, LOWER	4	
19	507538C	SPACER MC8079	4	
20	508345	BOLT, FLAT HEAD 3/8" NC X 3-1/2" G	4	
21	EM926036	RING, RETENTION	2	
22	514515	DRIVE PINION SHAFT	1	
23	492179	BEARING, PINION SHAFT	2	
24	EM963692	BOLT 1/2" NC X 1-1/2" G5	2	
25	502036	HOUSING, JACKSHAFT	1	
26	492584	LOCKNUT, HEX 1/2" NC	2	
27	491008	CAP, GREASE FITTING	3	
28	EM916001	GREASE FITTING 1/8" NPT	3	
29	500246	SQUARE KEY 1/4 X 35 MM	1	
30	503915	DRIVE PINION	1	
31	492468	ALLEN SCREW 5/16 NC 1/2"	1	
32	492491	SET SCREW 1/2" X 1" NC	1	
33	07037-024	NUT, HEX LOWER 1-1/2" NF	1	REPLACES EM968306
34	505079	BOLT 5/8" NC X 1-1/4" NC	1	
35	492586	LOCKNUT, HEX 5/8" NC	1	
36	510647	YOKE	1	
37	508496	BLADE, PLASTIC (SHOVEL)	2	
38	500980	WASHER, FLAT 1-9/16"	1	
39	505472	SPACER, BARREL	1	
40	515450	STEEL BLADES	3	EFFECTIVE 02/2005

STEEL BARREL ASSY.

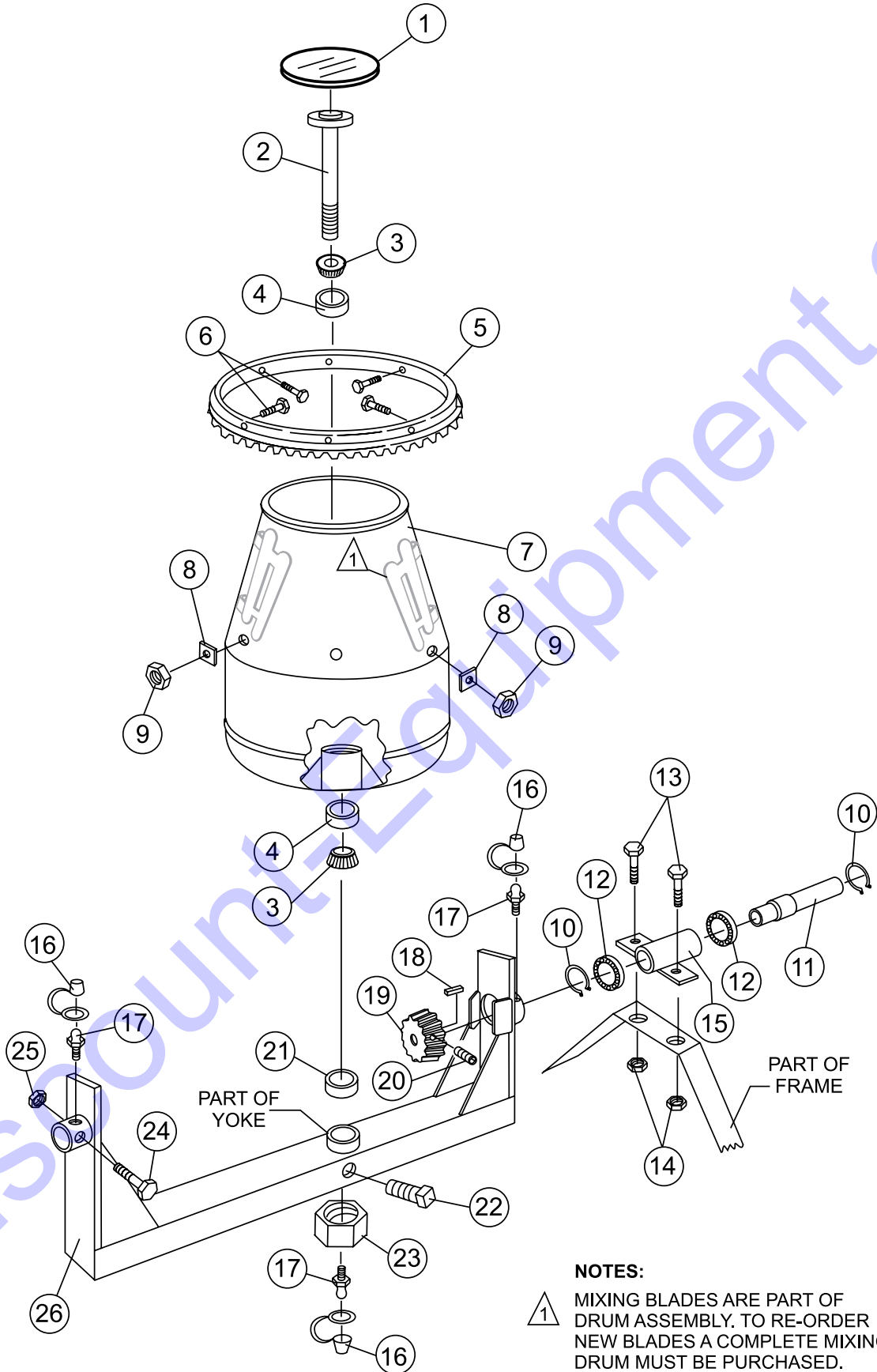

NOTES:

△ MIXING BLADES ARE PART OF DRUM ASSEMBLY. TO RE-ORDER NEW BLADES A COMPLETE MIXING DRUM MUST BE PURCHASED.

STEEL BARREL ASSY.

<u>NO.</u>	<u>PART NO.</u>	<u>PART NAME</u>	<u>QTY.</u>	<u>REMARK</u>
1	505390	PLUG, EXPANSION	1	
2	505469	KING PIN	1	
3	510955	SPINDLE BEARING CONE	2	
4	510956	SPINDLE BEARING CUP	2	
5	514061	RING GEAR	1	
6	EM9633057	BOLT 3/8" NC 1-1/2" G5	6	
7	505473	BARREL, STEEL 9 CU. FT.	1	
8	511732	SHIM 0.25 THICK	AR	
8	511729	SHIM .100 THICK	AR	
8	511730	SHIM .140 THICK	AR	
8	511731	SHIM .187 THICK	AR	
9	EM969013	NUT, LOCK 3/8" NC	6	
10	490962	SNAP RING	2	
11	514515	DRIVE PINION SHAFT	1	
12	492179	BEARING, PINION SHAFT	2	
13	EM963692	BOLT 1/2" NC X 1-1/2" G5	2	
14	492584	LOCKNUT, HEX 1/2" NC	2	
15	502036	HOUSING, JACKSHAFT	1	
16	491008	CAP, GREASE FITTING	3	
17	EM916001	GREASE FITTING 1/8" NPT	3	
18	500214	SQUARE KEY 1/4" X 30 MM	1	
19	503915	DRIVE PINION	1	
20	492467	ALLEN SCREW 5/16 NC 3/8"	1	
21	EM505472	SPACER, BARREL	1	
22	492491	SET SCREW 1/2" X 1" NC	1	
23	07037-024	NUT, HEX LOWER 1-1/2" NF	1	REPLACES EM968306
24	492406	BOLT 5/8" NC X 1-1/2" NC	1	
25	492586	LOCKNUT, HEX 5/8" NC	1	
26	510593	YOKE	1	

MAIN FRAME ASSY.

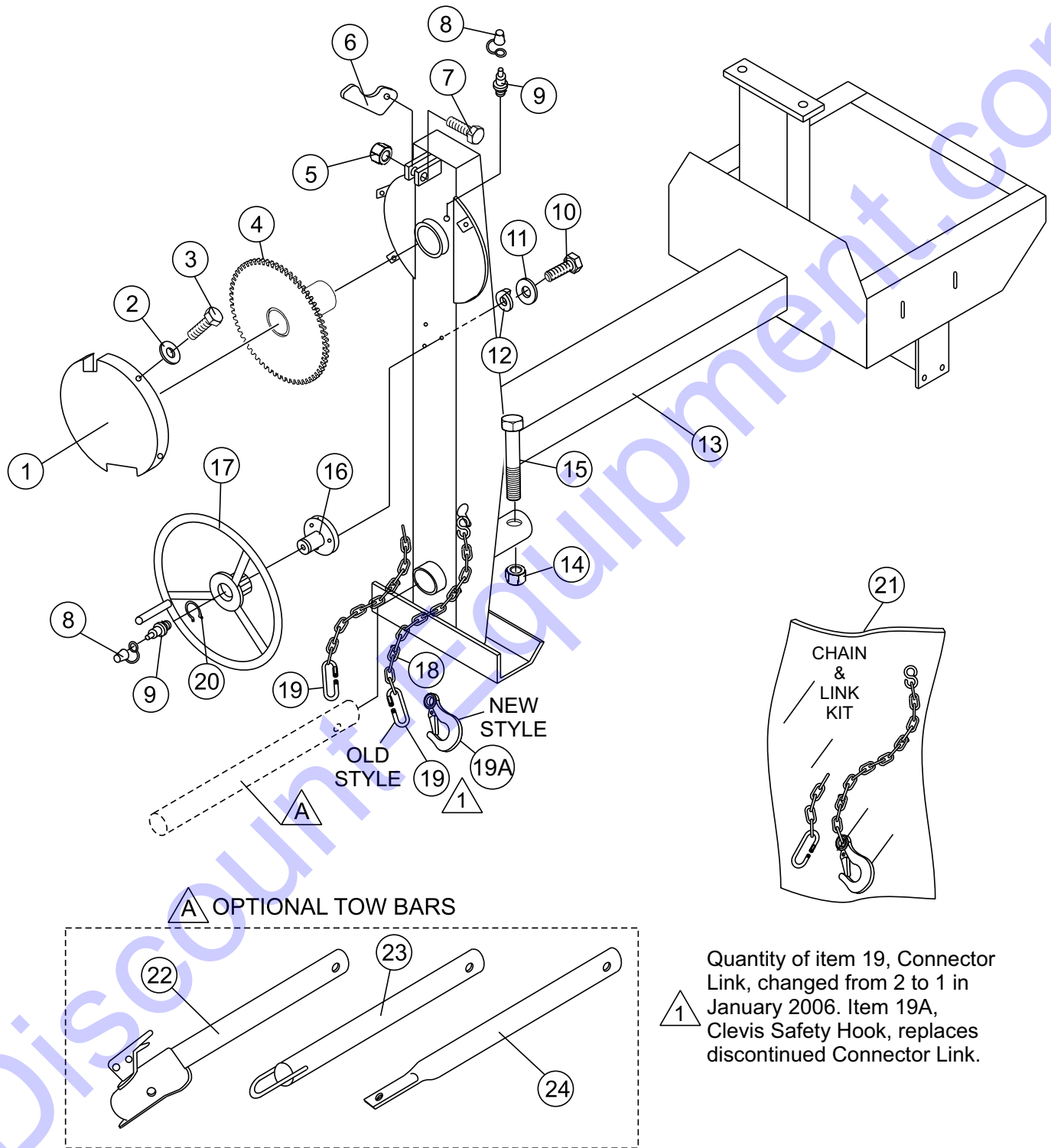

MAIN FRAME ASSY.

<u>NO.</u>	<u>PART NO.</u>	<u>PART NAME</u>	<u>QTY.</u>	<u>REMARK</u>
1	514245	GUARD, GEAR WHEEL	1	
2	492621	WASHER, LOCK 1/4"	4	
3	492278	ROUND HEAD BOLT 1/4" NC 3/8 G2"	4	
4	514692	DUMP GEAR	1	
5	492584	NUT, LOCK 1/2" NC	1	
6	490895	DUMP LATCH	1	
7	492395	BOLT 1/2" NC X 1-3/4" G5	1	
8	EM916001	GREASE FITTING 1/8" NPT	2	
9	491008	GREASE CAP	2	
10	EM963055	BOLT 3/8" NC X 3/4" G5	3	
11	3109092	WASHER, FLAT 3/8"	3	
12	0166 A	WASHER, LOCK 3/8"	3	
13	514521	FRAME	1	
14	10176	LOCK NUT 1/2 NC	1	
15	EM124	BOLT 1/2"-13 X 4 G5	1	
16	514723	HANDWHEEL SHAFT	1	
17	501808	HANDWHEEL.....	1	REPLACES P/N 514002
18*		SAFETY CHAIN	1	
19*	01004	CONNECTOR LINK.....	2	BEFORE JANUARY 2006
19*	01004	CONNECTOR LINK.....	1	AFTER JANUARY 2006
19A*	516580	CLEVIS SAFETY HOOK, 1/4".....	1	AFTER JANUARY 2006
20	490961	SNAP RING	1	
21	13363KIT	CHAIN AND LINK KIT.....	1	INCLUDES ITEMS W/*
22	HBC-1	BALL HITCH 2-INCH.....	1	CONTACT UNIT SALES
23	HLC-1	LOOP HITCH.....	1	CONTACT UNIT SALES
24	HPC-1	PIN HITCH 1-INCH.....	1	CONTACT UNIT SALES

AXLE ASSY.

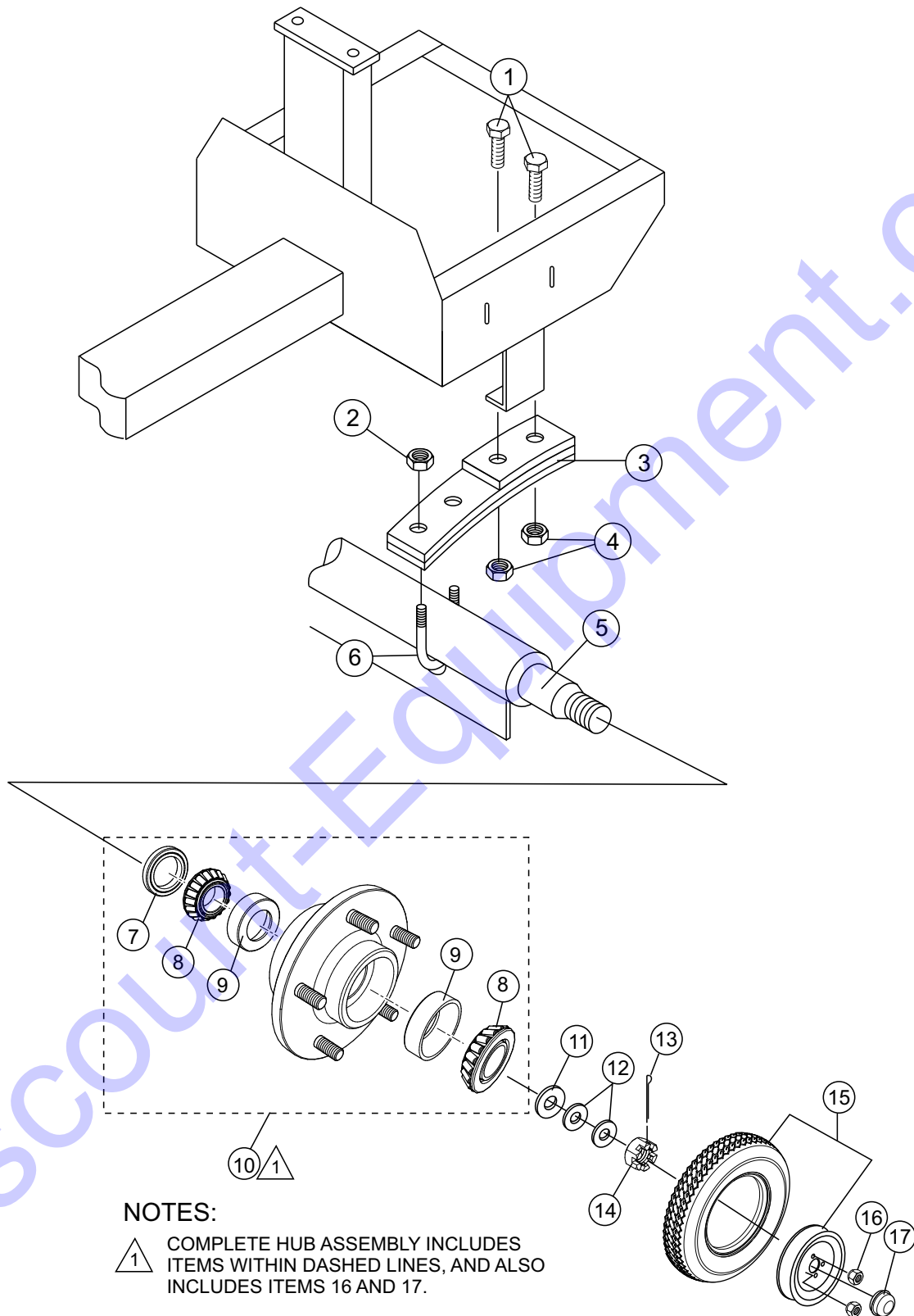

NOTES:

- 1 COMPLETE HUB ASSEMBLY INCLUDES ITEMS WITHIN DASHED LINES, AND ALSO INCLUDES ITEMS 16 AND 17.

AXLE ASSY.

<u>NO.</u>	<u>PART NO.</u>	<u>PART NAME</u>	<u>QTY.</u>	<u>REMARK</u>
1	492397	BOLT 1/2" NC 2-1/2" G5	4	
2	492589	NUT 1/2" NF	4	
3	491928	SPRING LEAF	2	
4	492584	NUT, HEX 1/2"	4	
5	514545	AXLE	1	
6	500617	U-CLAMP	2	
7#	EM914288	OIL SEAL	2	
8#	EM903113	BEARING CONE,	4	
9#	EM903012	BEARING CUP	4	
10	EM941306	HUB ASSY., 4-BOLT (1-1/16" SPINDLE).....	2.....	INCLUDES ITEMS W/#
11	EM511159	WASHER, FLAT, .087" THICKNESS	2	
12	EM501299	WASHER, FLAT, .135" THICKNESS	AR	
13	491688	COTTER PIN 1/8" X 1-1/2'	2	
14	8164	NUT, SLOTTED HEX JAM 1"-20	2	
15	3005	TIRE AND RIM	2	
16#	8115	LUG NUTS	8	
17#	3469	DUST CAP	2	

CABINET ASSY.

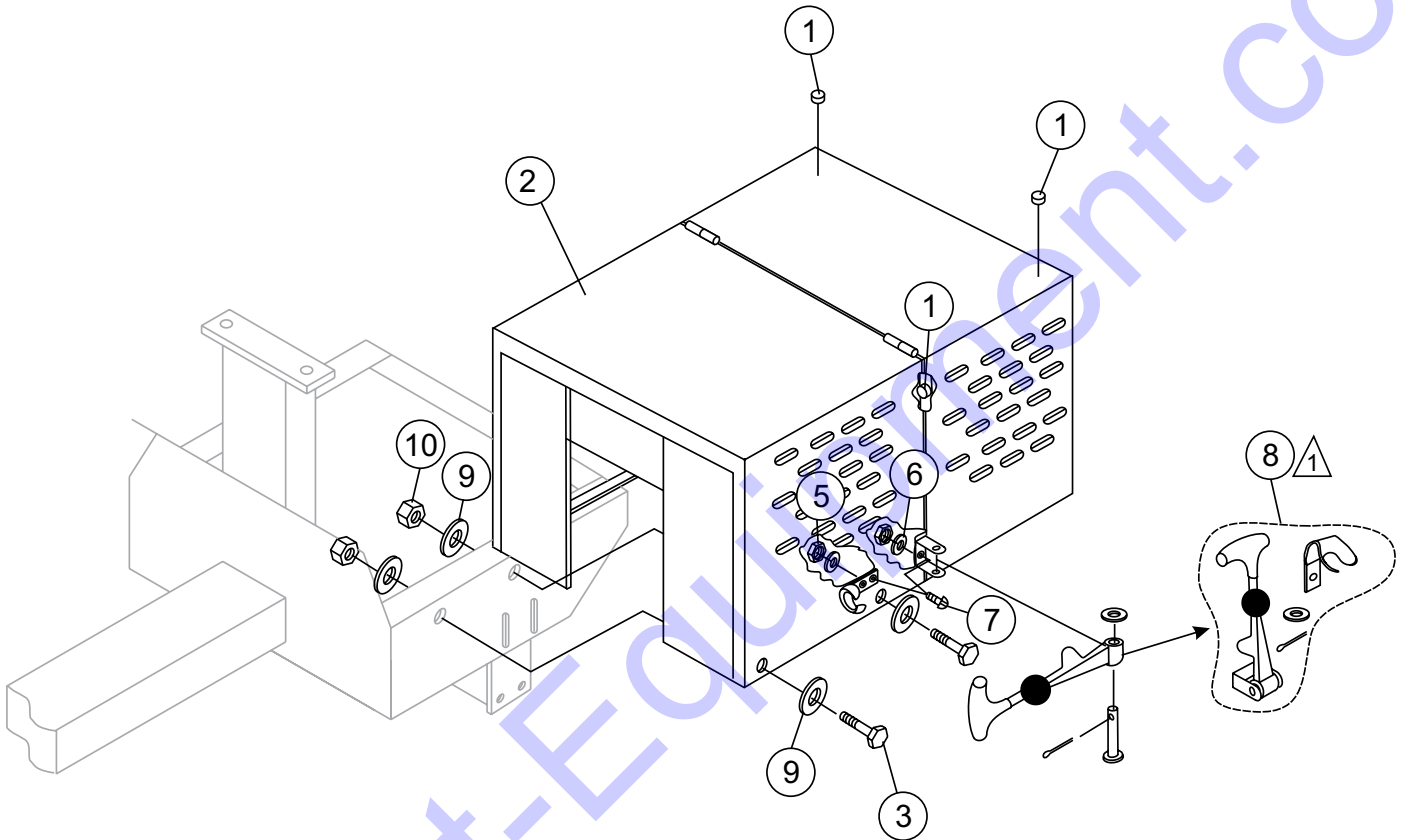

NOTES:



COMPLETE LATCH ASSEMBLY
INCLUDES ITEMS WITHIN DASHED
LINES. ITEMS CANNOT BE PURCHASED
SEPARATELY.

CABINET ASSY.

<u>NO.</u>	<u>PART NO.</u>	<u>PART NAME</u>	<u>QTY.</u>	<u>REMARKS</u>
1	490202	RUBBER PROTECTOR	4	
2	514694	ENGINE HOUSING CABINET W/DECALS	1	INCLUDES ITEM W/*
3	492375	BOLT 3/8" NC X 1" G5	6	
4	EM923023	WASHER, FLAT 5/16"	8	
5	13287	LOCK NUT 8-32.....	6.....	REPLACEMENT PART ONLY
6	2203	WASHER, FLAT #10.....	6.....	REPLACEMENT PART ONLY
7	1307	RHMS 8-32 X 1/2".....	6.....	REPLACEMENT PART ONLY
8*	491010	LATCH ASSY., COMPLETE	2	
9	492598	WASHER, FLAT 3/8"	12	
10	2105164	NUT 3/8" NC G5	6	

GAS ENGINE MOUNTING PLATE ASSY.

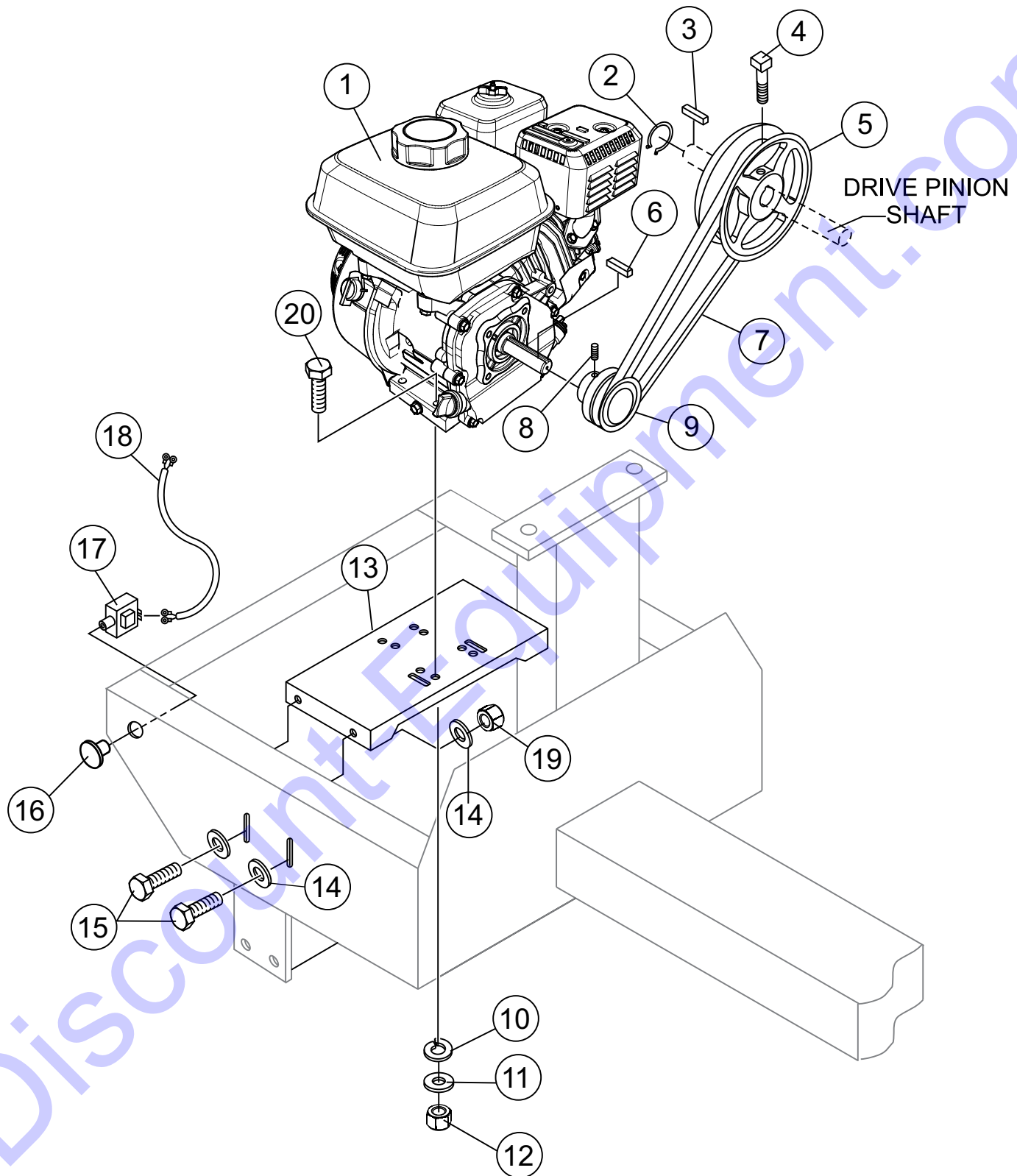

GAS ENGINE MOUNTING PLATE ASSY.

<u>NO.</u>	<u>PART NO.</u>	<u>PART NAME</u>	<u>QTY.</u>	<u>REMARKS</u>
1	GX240UT1QA2	ENGINE, HONDA 8.0 HP	1.....	REPLACES GX240K1QA2 ENG.
2	490956	SNAP RING	1	
3	500275	SQUARE KEY 1/4 X 40 MM	1	
4	492468	SET SCREW 5/16" NC X 3/4"	1	
5	514060	UPPER PULLEY	1	
6	90745ZE2600	SQUARE KEY 6.3 X 6.3 X 43 MM 8.0 HP	1	
7	493399	V-BELT B-55 8.0 HP	1	
8	492468	ALLEN SCREW 5/16" NC X 3/8"	1	
9	504075	DRIVE PULLEY 8.0 HP	1	
10	EM923343	WASHER, LOCK 5/16"	4	
11	EM923023	WASHER, FLAT 5/16"	4	
12	2105164	NUT, HEX 5/16 X18 NC G5	4	
13	514810	BASE PLATE, ENGINE	1	
14	492600	WASHER, FLAT 1/2"	8	
15	EM963692	BOLT, HEX 1/2" NC 1-1/2" G5	4	
16	29174-001	BUTTON, STOP	1	
17	29173-001	SWITCH, STOP	1	
18	510573C	ENGINE CABLE HARNESS	1	
19	492584	LOCKNUT 1/2"	4	

ELECTRIC MOTOR MOUNTING PLATE ASSY.

<u>NO.</u>	<u>PART NO.</u>	<u>PART NAME</u>	<u>QTY.</u>	<u>REMARKS</u>
1	P145K17DB45A	MOTOR, ELECTRIC 1.5 HP	1	
2	490960	SNAP RING	1	
3	500275	SQUARE KEY 1/4" X 40 MM	1	
4	492476	SET SCREW 5/16" NC X 3/4"	1	
5	514060	UPPER PULLEY	1	
6	500169	SQUARE KEY 3/16" X 50 MM	1	
7	512265	V-BELT B-59	1	
8	492468	ALLEN SCREW 5/16" NC X 1/2"	1	
9	514923	DRIVE PULLEY	1	
10	EM923343	WASHER, LOCK 5/16"	4	
11	EM923023	WASHER, FLAT 5/16"	4	
12	2105164	NUT, HEX 5/16 X18 NC G5	4	
13	514810	BASE PLATE, ENGINE	1	
14	492600	WASHER, FLAT 1/2"	8	
15	EM963692	BOLT, HEX 1/2" NC 1-1/2" G5	4	
16	492584	LOCKNUT 1/2"	4	
17	492367	BOLT 5/16" X 1-3/4" G5	4	

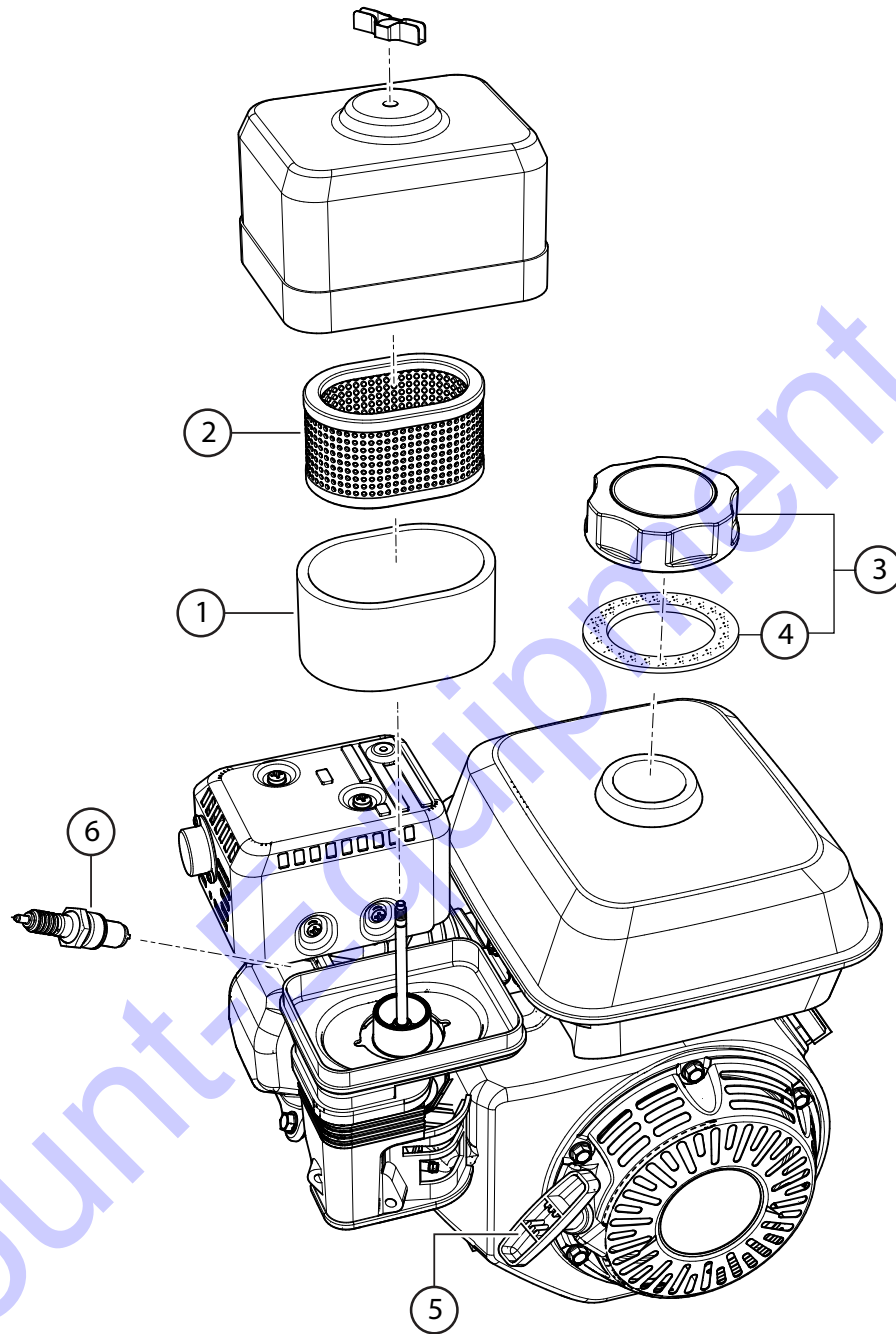

ENGINE SERVICE PARTS

NO.	PART NO.	PART NAME	QTY.	REMARKS
1	17218ZE2505	FILTER, OUTER	1	
2♣	17210ZE2515	AIR CLEANER ELEMENT	1	
2◇	17210ZE2822	AIR CLEANER ELEMENT (DUAL)	1	
3♣	17620ZH7023	TANK CAP	1	INCLUDES ITEM W/%
3◇	17620Z4H020	TANK CAP	1	INCLUDES ITEM W/\$
4%	17631ZH7003	GASKET	1	
4\$	17631Z0T801	GASKET	1	
5	28462ZE2W11	ROPE, RECOIL	1	
6	9807956855	SPARK PLUG, DENSO	1	

NOTICE

- ♣ HONDA GX240K1QA2
- ◇ HONDA GX240UT1QA2

Discount Equipment

Discount-Equipment.com is your online resource for commercial and industrial quality parts and equipment sales.

Locations:

Florida (West Palm Beach): [561-964-4949](tel:561-964-4949)

Outside Florida TOLL FREE: [877-690-3101](tel:877-690-3101)

Need parts? Check out our website at www.discount-equipment.com

Can't find what you need?

Click on this link: <http://www.discount-equipment.com/category/5443-parts/> and fill out the request form.

Please have the machine model and serial number available in order to help us get you the correct parts. One of our experienced staff members will get back to you with a quote for the right part that your machine needs.

We sell worldwide for the brands: Genie, Terex, JLG, MultiQuip, Mayco, Toro/Stone, Diamond Products, Magnum, Airman, Mustang, Power Blanket, Nifty Lift, Atlas Copco, Chicago Pneumatic, Allmand Brothers, Essick, Miller Spreader, Skyjack, Lull, Skytrak, Tsurumi, Husquvarna/Target, Whiteman-Concrete/Mortar, Stow-Concrete/Mortar, Baldor, Wacker, Sakai, Snorkel, Upright, Mi-T-M, Sullair, Neal, Basic, Dynapac, MBW, Weber, Bartell, Bennar Newman, Haulotte, Ditch Runner, Blaw-Knox, Himoina, Best, Buddy, Crown, Edco, Wyco, Bomag, Laymor, Terremite, Barreto, EZ Trench, Takeuchi, Basic, Bil-Jax, Curtis, Gehl, Heli, Honda, ICS/PowerGrit, Puckett, Waldon, ASV, IHI, Partner, Imer, Clipper, MMD, Koshin, Rice, Gorman Rupp, CH&E, Cat Pumps, Comet, General Pump, Giant, AMida, Coleman, NAC, Gradall, Square Shooter, Kent, Stanley, Tamco, Toku, Hatz, Kohler, Robin, Wisconsin, Northrock, Oztec, Toker TK, Rol-Air, Small Line, Wanco, Yanmar

New Equipment - Used Equipment - Rental Equipment - Parts and Accessories

Discount Equipment

www.discount-equipment.com

561-964-4949

Parts: wbparts@Discount-Equipment.com

Sales: info@Discount-Equipment.com