

COMMONLY USED PARTS MANUAL

Revised June 2012

**Curbilder Models:
MC-550, MC-650,
MC-655 Under Guard Rail
MC-850, MC-900**



Part #35001



www.discount-equipment.com

Discount Equipment

Discount-Equipment.com is your online resource for commercial and industrial quality parts and equipment sales.

Locations:

Florida (West Palm Beach): [561-964-4949](tel:561-964-4949)

Outside Florida TOLL FREE: [877-690-3101](tel:877-690-3101)

Need parts? Check out our website at www.discount-equipment.com

Can't find what you need?

Click on this link: <http://www.discount-equipment.com/category/5443-parts/> and fill out the request form.

Please have the machine model and serial number available in order to help us get you the correct parts. One of our experienced staff members will get back to you with a quote for the right part that your machine needs.

We sell worldwide for the brands: Genie, Terex, JLG, MultiQuip, Mayco, Toro/Stone, Diamond Products, Magnum, Airman, Mustang, Power Blanket, Nifty Lift, Atlas Copco, Chicago Pneumatic, Allmand Brothers, Essick, Miller Spreader, Skyjack, Lull, Skytrak, Tsurumi, Husquvarna/Target, Whiteman-Concrete/Mortar, Stow-Concrete/Mortar, Baldor, Wacker, Sakai, Snorkel, Upright, Mi-T-M, Sullair, Neal, Basic, Dynapac, MBW, Weber, Bartell, Bennar Newman, Haulotte, Ditch Runner, Blaw-Knox, Himoina, Best, Buddy, Crown, Edco, Wyco, Bomag, Laymor, Terremite, Barreto, EZ Trench, Takeuchi, Basic, Bil-Jax, Curtis, Gehl, Heli, Honda, ICS/PowerGrit, Puckett, Waldon, ASV, IHI, Partner, Imer, Clipper, MMD, Koshin, Rice, Gorman Rupp, CH&E, Cat Pumps, Comet, General Pump, Giant, AMida, Coleman, NAC, Gradall, Square Shooter, Kent, Stanley, Tamco, Toku, Hatz, Kohler, Robin, Wisconsin, Northrock, Oztec, Toker TK, Rol-Air, Small Line, Wanco, Yanmar

New Equipment - Used Equipment - Rental Equipment - Parts and Accessories

Discount Equipment

www.discount-equipment.com

561-964-4949

Sales: info@Discount-Equipment.com

Parts: wbparts@Discount-Equipment.com

ABBREVIATED PARTS LISTING

showing most commonly used parts for

MC550/650/655/850/900 Curbilder

Curbilder Commonly Used Parts:

ITEM	QTY per Machine	Part #	DESCRIPTION
1	1/2	45018-15	3/8" diameter Shear Bolt , Nut and Lock Washer for Solid Auger.
2	2/4/6	45120-14	1/2" diameter Shear Bolt (with Machined end) and Lock Washer for Hollow Auger.
3	1	45023-01	1-1/4" diameter Solid Auger Shaft X 29-7/8" Overall Length.
4	1	45023-08	1-1/4" diameter Hollow Auger Shaft X 29-7/8" Overall Length.
5	3	BE0200	1-1/4" Bore Four(4) Bolt Flange Bearing.
6	1	SK0200	15 Tooth Sprocket for Gearbox Output Shaft.
7	1	SK0300	23 Tooth Sprocket for Auger Shaft.
8	1	45016-16	Idler Sprocket Assembly (Includes Sprocket). For Left Hand Position.
9	1	CL0200	Centrifugal Clutch with 1" diameter bore.
10	2	45050-15	Drive Belts. Solid Construction for Models MC-550, MC-650, MC-655
11	2	45050-23	Drive Belts. Cogged Construction for Models MC-850, MC-900.

ITEM	QTY per Machine	PART#	DESCRIPTION
12	1	45059-07	Tie Rod Assembly.
13	4/9	WT0100	2" Wide X 8" Diameter Solid Rubber Wheel.
14	6/9	45094-14	2-1/2" Wide X 8" Diameter Heavy Duty Solid Rubber Wheel.
15	1	45050-10	Drive Chain with Connecting Link
16	2	Hardware	1/4" x 2" Long CRSQ Key for items 6 & 7
17	1	45122-01	5" Compaction Tube
18	1	45121-11	5" Auger Housing w/ Shaft Guard
19	2	45018-18	5" Cast Auger X 9"Lg. for Solid Shaft
20	2	45018-19	5" Cast Auger X 9"Lg. for Hollow Shaft
21	1	45014-01	6" Fabricated Compaction Tube
22	1	45014-06	6" Cast Compaction Tube
23	1	45010-14	6" Auger Housing w/ Shaft Guard
24	2/3	45018-09	6" Cast Auger X 9'Lg. for Solid Shaft
25	2/3	45018-11	6" Cast Auger X 9"Lg. for Hollow Shaft
26	1	45128-01	8" Compaction Tube
27	1	45127-11	8" Auger Housing w/ Shaft Guard
28	1	45126-01	8" Steel Auger X 18" Lg. for Solid Shaft Not Shown
29	1	45126-07	8" Steel Auger X 18"Lg. for Hollow Shaft Not Shown
30	1	45036-18	Rear Wheel Upright Assembly w/Crank for machines built prior to July 2006 having ROUND rear frame cross member.
31	1	45034-01	Rear Wheel Upright Assembly w/Crank for machines built after to July 2006 having SQUARE rear frame cross member.

Machine Parts:

- ⑫ 2" WIDE WHEEL
- ⑬ 2-1/2" WIDE WHEEL

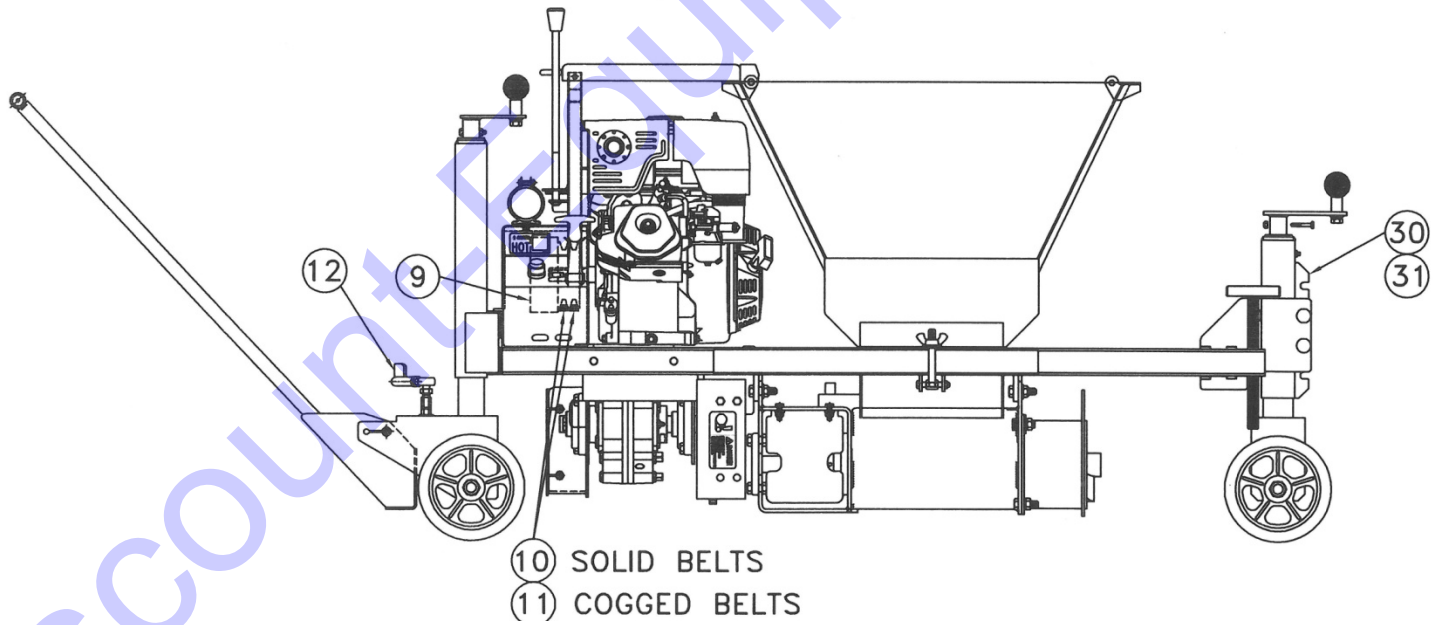
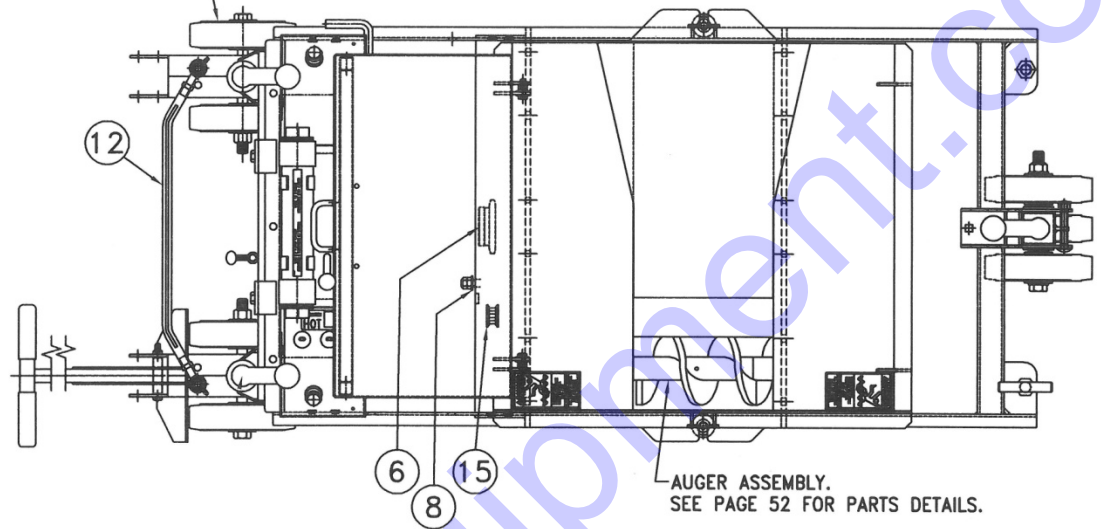

Solid and Hollow Auger Assemblies:

TORQUE SPECIFICATIONS:

- 1) TORQUE ALL 1/2"-13NC HARDWARE TO SIXTY(60) FT.LBS.
- 2) TORQUE 3/8"-16NC GRADE 8 AUGER BOLTS (1) TO THIRTY-FIVE(35) FT.LBS.
- 3) TORQUE 5/16"-24NF SET SCREWS ON BEARINGS (5) AND SPROCKET (7) TO TWENTY-FIVE(25) FT.LBS. FOUR(4) PLACES.

APPLY RED PERMALOCK 126 TO ALL SET SCREW THREADS.

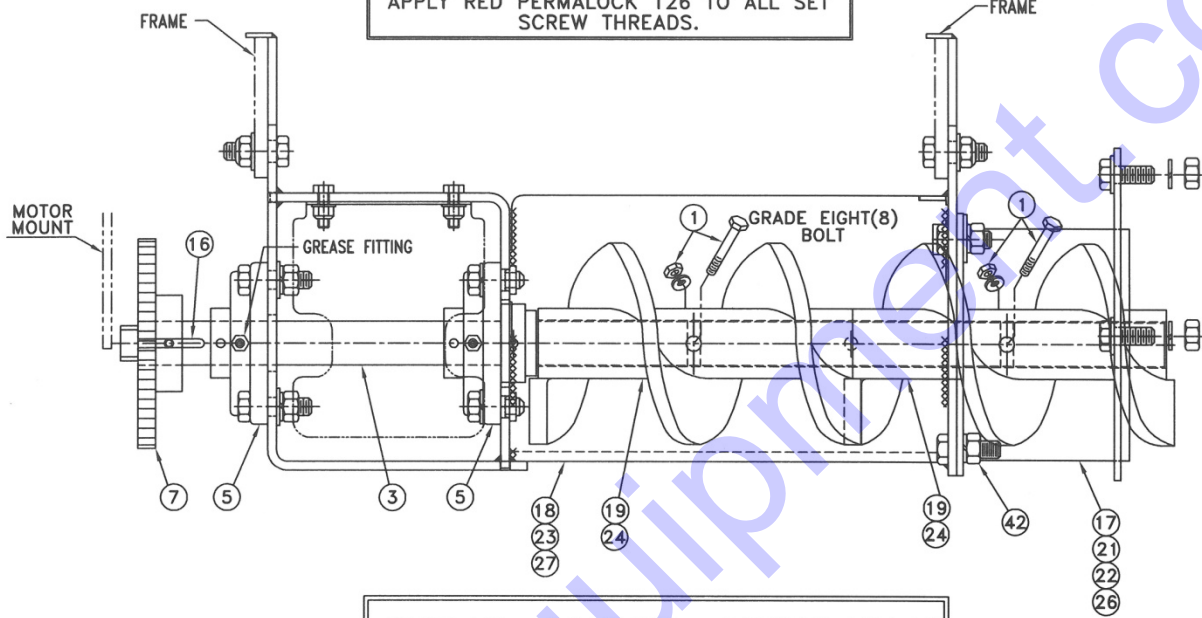

SOLID AUGER ASSEMBLY

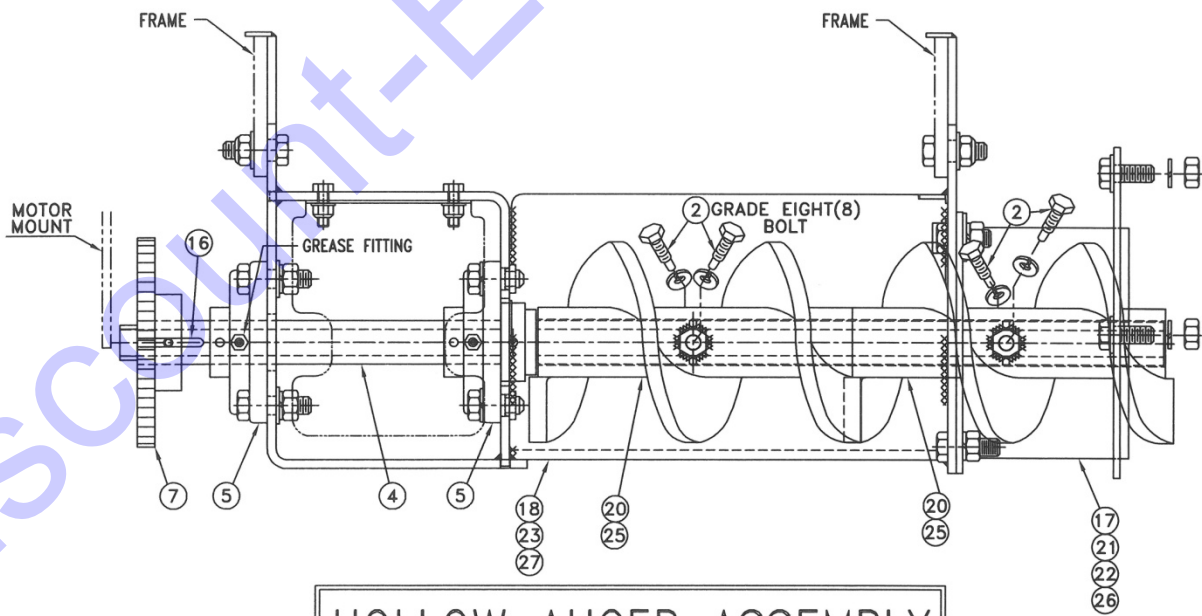

HOLLOW AUGER ASSEMBLY