

GENERAC® | MAGNUM

DIESEL LIGHT TOWER MLT4200IF4

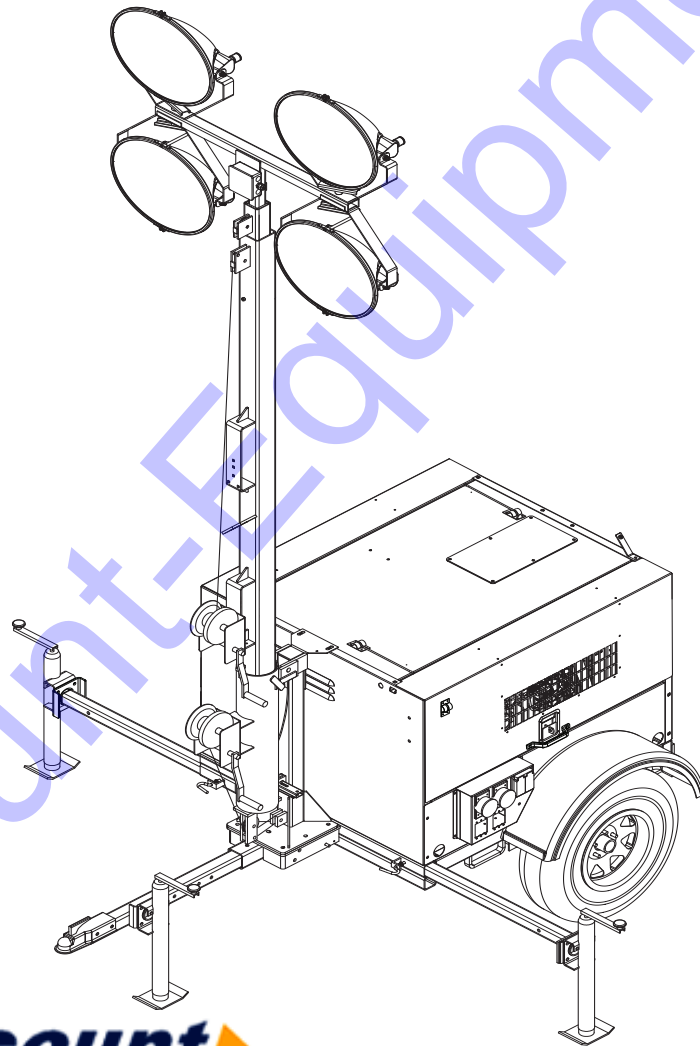

**Discount
Equipment**

www.discount-equipment.com

PARTS MANUAL

01756

Discount Equipment

Discount-Equipment.com is your online resource for commercial and industrial quality parts and equipment sales.

Locations:

Florida (West Palm Beach): [561-964-4949](tel:561-964-4949)

Outside Florida TOLL FREE: [877-690-3101](tel:877-690-3101)

Need parts? Check out our website at www.discount-equipment.com

Can't find what you need?

Click on this link: <http://www.discount-equipment.com/category/5443-parts/> and fill out the request form.

Please have the machine model and serial number available in order to help us get you the correct parts. One of our experienced staff members will get back to you with a quote for the right part that your machine needs.

We sell worldwide for the brands: Genie, Terex, JLG, MultiQuip, Mayco, Toro/Stone, Diamond Products, Magnum, Airman, Mustang, Power Blanket, Nifty Lift, Atlas Copco, Chicago Pneumatic, Allmand Brothers, Essick, Miller Spreader, Skyjack, Lull, Skytrak, Tsurumi, Husquvarna/Target, Whiteman-Concrete/Mortar, Stow-Concrete/Mortar, Baldor, Wacker, Sakai, Snorkel, Upright, Mi-T-M, Sullair, Neal, Basic, Dynapac, MBW, Weber, Bartell, Bennar Newman, Haulotte, Ditch Runner, Blaw-Knox, Himoina, Best, Buddy, Crown, Edco, Wyco, Bomag, Laymor, Terremite, Barreto, EZ Trench, Takeuchi, Basic, Bil-Jax, Curtis, Gehl, Heli, Honda, ICS/PowerGrit, Puckett, Waldon, ASV, IHI, Partner, Imer, Clipper, MMD, Koshin, Rice, Gorman Rupp, CH&E, Cat Pumps, Comet, General Pump, Giant, AMida, Coleman, NAC, Gradall, Square Shooter, Kent, Stanley, Tamco, Toku, Hatz, Kohler, Robin, Wisconsin, Northrock, Oztec, Toker TK, Rol-Air, Small Line, Wanco, Yanmar

New Equipment - Used Equipment - Rental Equipment - Parts and Accessories

Discount Equipment

www.discount-equipment.com

561-964-4949

Sales: info@Discount-Equipment.com

Parts: wbparts@Discount-Equipment.com

⚠ WARNING

CALIFORNIA PROPOSITION 65 WARNING: Diesel engine exhaust and some of its constituents are known to the state of California to cause cancer, birth defects, and other reproductive harm.

⚠ WARNING

CALIFORNIA PROPOSITION 65 WARNING: This product contains or emits chemicals known to the state of California to cause cancer, birth defects, and other reproductive harm.

⚠ WARNING

ENVIRONMENTAL HAZARD: Always recycle batteries at an official recycling center in accordance with all local laws and regulations. Failure to do so could result in environmental damage, death or serious injury.

Introduction

This parts manual was prepared based on the information available at the time of publication and is subject to change without notice. Generac Mobile Products reserves the right to change parts at any time.

DO NOT MODIFY or use this equipment for any application other than which it was designed for. To keep your equipment fully operational, it is suggested you maintain a stock of commonly used maintenance or service parts. A recommended spare parts list can be found in the back of this manual.

▲ WARNING

Before operating or servicing this equipment, read and understand the Generac Mobile Products Operating Manual which was included with the unit when shipped from the factory. Failure to do so increases the risk of injury to yourself or others.

Engine Make: _____

Engine Serial Number: _____

Engine Model Number: _____

Generator Make: _____

Generator Model Number: _____

Generator Serial Number: _____

Unit Model Number: _____

Unit Serial Number: _____

Table of Contents

Introduction	iii
Parts Manual Instructions	1
Unit Decals - Exterior	2
Unit Decals - Left Side and Interior	4
Unit Decals - Right Side and Interior	6
Mast, Junction Box and Lights to Unit	8
Light Assembly	10
Mast Junction Box - Hard Wired	12
Mast Junction Box - Quick Disconnect	14
Mast Assembly - Manual Winch	16
Mast Assembly - Electric Winch (Prior To 9-29-2015)	18
Roof and Doors to Unit	20
Door Assembly	22
Front, Rear and Side Panels to Unit	24
Receptacle Box Assembly	26
Receptacle Panel Options	28
Control Box and Fuel System to Unit	30
Fuel Filter Hoses	32
Control Box Assembly	34
Control Panel Assembly	36
Cooling System Assembly	38
Engine and Generator to Unit	40
Engine Assembly - Left Side	42
Engine Assembly - Right Side	44
Generator Assembly	46
Fuel Tank and Transformers to Unit	48
Trailer Assembly	50
Trailer Options	52
Axle Assembly	54
Recommended Spare Parts List	56

Parts Manual Instructions

Product illustrations are only representations. Products supplied may vary from the illustrations in this parts manual. Parts not shown in the illustration are indicated by a double dash (--) in the item column.

Please be prepared to provide the following information when ordering replacement parts: model number, serial number (on unit serial tag), part number, purchase order number (if applicable), shipping address, shipping method.

Refer to the illustration below to locate the unit ID tag and Vehicle Identification Number (VIN) tag on the unit. Important information, such as the unit serial number, model number, VIN and tire loading information are found on these tags. Record the information from these tags so it is available if the tags are lost or damaged. When ordering parts or requesting assistance, you may be asked to provide this information.

VIN Tag

MANUFACTURED BY/FOR: Generic Mobile Products, LLC		DATE: 05/08/20
COUNTRY OF ORIGIN: USA		MODEL: MLT4200IF4
UNIT NO: 00000000000000000000	TYPE: TRAILER	
TIRE AND LOADING INFORMATION THIS INFORMATION IS FOR THE USER'S REFERENCE ONLY. PLEASE DO NOT EXCEED THE WEIGHTS LISTED. The weight of cargo should never exceed 2000kg (4400 lbs) or 10% of the GVWR, whichever is less.		
SEE OWNER'S MANUAL FOR TIRE INFORMATION. ALWAYS USE PROPER TIRE INFLATION PRESSURE. ALWAYS USE PROPER TIRE ROTATION.		

Unit ID Tag
Located on inside of front panel

Country of Origin: USA		Serial Number: 0000000000
Manufacturing Code: 0000	Part Number: 0000	Quantity: 0000
SKU: 0000	1. Jan. 1997	2. Jan. 2007
UPC: 0000	3. Jan. 2007	4. Jan. 2007
W: 0000		
A: 0000		

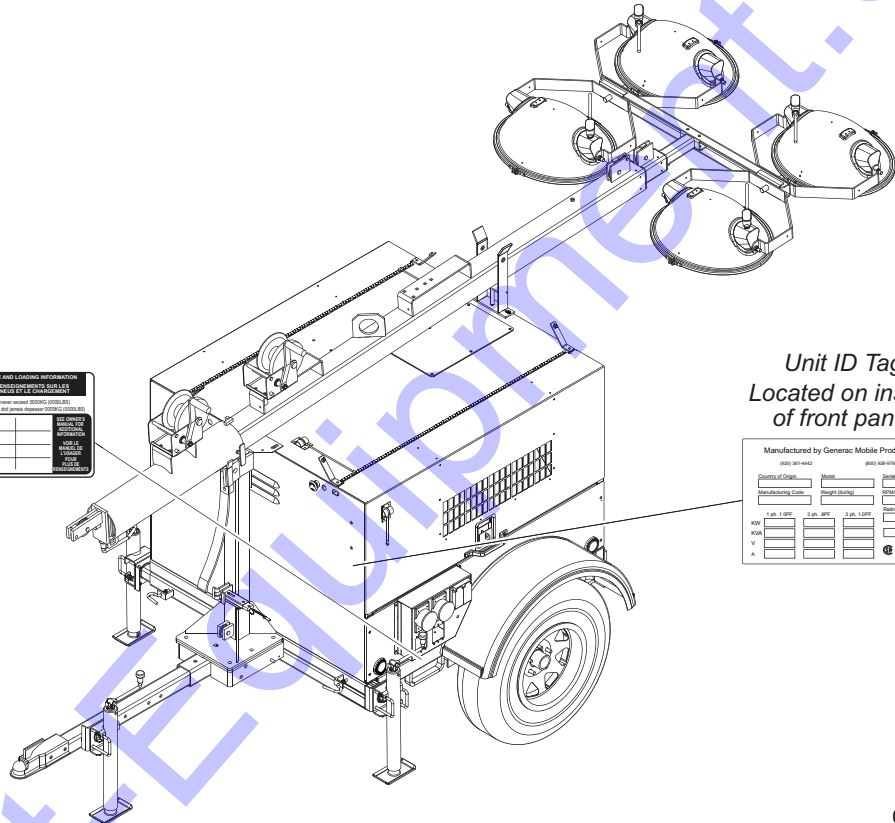

01561

UNIT DECALS - EXTERIOR

Item	Part No.	Qty	Description	Notes
1	37223	1	Decal, safety	
2	10792	1	Decal, aux outlet breakers - 50,50,30,30,20,20	
3	12142	2	Decal, ground	

Discount-Equipment.com

UNIT DECALS - LEFT SIDE AND INTERIOR

1

SET UP / AUFSTELLUNG / INSTALACIÓN / INSTALLATION

TAKE DOWN / ABBAU / DESINSTALACIÓN / DÉMONTAGE

2

STARTING THE GENERATOR
DAS STARTEN DES GENERATORS
COMENZO DEL GENERADOR
COMMENCEMENT DU GENERATEUR

1. TURN CONTROL SWITCH "ON"
 2. PUSH "START"

STOPPING THE GENERATOR
DAS AUFHÖREN DES GENERATORS
PARADA DEL GENERADOR
ARRÊT DU GENERATEUR

1. PUSH "STOP"
 2. TURN CONTROL SWITCH "OFF"

CONTROL ON 1. ⬆️ 2. ⬇️
 CONTROL OFF 1. ⬆️ 2. ⬇️

3

⚠️ DANGER

⚡ OVERHEAD POWER LINES
 Contact with overhead electrical power lines will cause serious injury or death. Do not position light tower under electrical power lines.

⚠️ GEFAHR
 Der Kontakt mit elektrischen Hochspannungsleitungen kann zu schweren oder lebensgefährlichen Verletzungen führen. Das Belichtungsgerüst nie direkt unter Hochspannungsleitungen aufstellen.

⚠️ PELIGRO
 El contacto con las líneas eléctricas elevadas podría causar lesiones serias o la muerte. No posicione la torre de iluminación debajo de líneas eléctricas.

⚠️ DANGER
 Le contact avec des câbles électriques suspendus causera des blessures graves ou la mort. Ne pas positionner la tour lumineuse sous des câbles électriciens.

3

⚠️ WARNING

⚡

⚠️ WARNING

⚠️ ADVERTENCIA

⚠️ AVERTISSEMENT

3

⚠️

⚠️

3

⚡ Disconnect battery before servicing.
 Vor der Instandsetzung die Batterieverbindungen lösen.
 Desconecte la batería antes de realizar el servicio técnico.
 Débrancher la batterie avant de faire l'entretien.

Located on battery

3

⚡ **⚠️ DANGER** **⚠️ GEFAHR** **⚠️ PELIGRO** **⚠️ DANGER** **⚠️**

Located behind control panel

2

REMOTE START/TERMINAL CONNECTIONS

FERNSTART/KLEMMENBELEGUNG
ARRANQUE REMOTO/CONEXIONES DE TERMINALES
DÉMARRAGE À DISTANCE ET BRANCHEMENTS AU TERMINAL

01563

UNIT DECALS - LEFT SIDE AND INTERIOR

Item	Part No.	Qty	Description	Notes
1	37224	1	Decal, setup	
2	37598	1	Decal, start DSE401	
3	37223	1	Decal, safety	

Discount-Equipment.com

UNIT DECALS - RIGHT SIDE AND INTERIOR

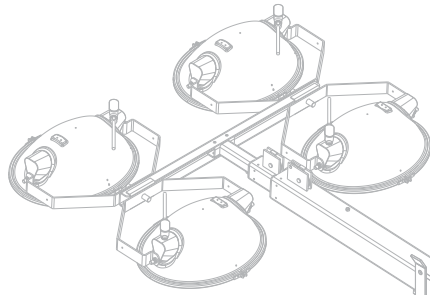

TOWING INSTRUCTIONS	ABSCHLEPPANWEISUNGEN	INSTRUCCIONES PARA REMOLQUE	INSTRUCCIONES DE REMORQUE
1. Read operator's manual. 2. Use hitch rated for trailer's "gross vehicle weight rating." 3. Securely attach trailer to tow vehicle. 4. Attach safety chains using a cross system. Attach crossmembers inside to vehicle. 5. Check trailer lights.	1. Handbuch des Fahrers lesen. 2. Anhängersicherung verwenden, die der "Gesamtfahrzeuggestichtgewicht" des Anhängers entspricht. 3. Anhänger sicher an Fahrzeug anbringen. 4. Sicherheitsketten über Kreuz anbringen. Anhängersicherungen innerhalb des Fahrzeuges anbringen. 5. Anhängersicherungen prüfen.	1. Use manual of operator. 2. Use an engine hitch rated for the "gross weight" of the trailer. 3. Engage frame and tongue to vehicle. 4. Attach safety chains to vehicle. 5. Engage the crossmembers to vehicle. 6. Check lights.	1. Lire le manuel de l'opérateur. 2. Utiliser un attelage autorisé au poids maximal brut de la remorque. 3. Arrêter solidement la remorque au véhicule tracteur. 4. Fixer les chaînes de sécurité en croix. 5. Fixer les traverses de remorque au véhicule. 6. Vérifier les feux de la remorque.

1

⚠ WARNING

⚠ WARNUNG
⚠ ADVERTENCIA
⚠ AVERTISSEMENT

1

⚠ WARNING

⚠ WARNUNG
⚠ ADVERTENCIA
⚠ AVERTISSEMENT

1

⚠ WARNING

⚠ WARNUNG
⚠ ADVERTENCIA
⚠ AVERTISSEMENT

1

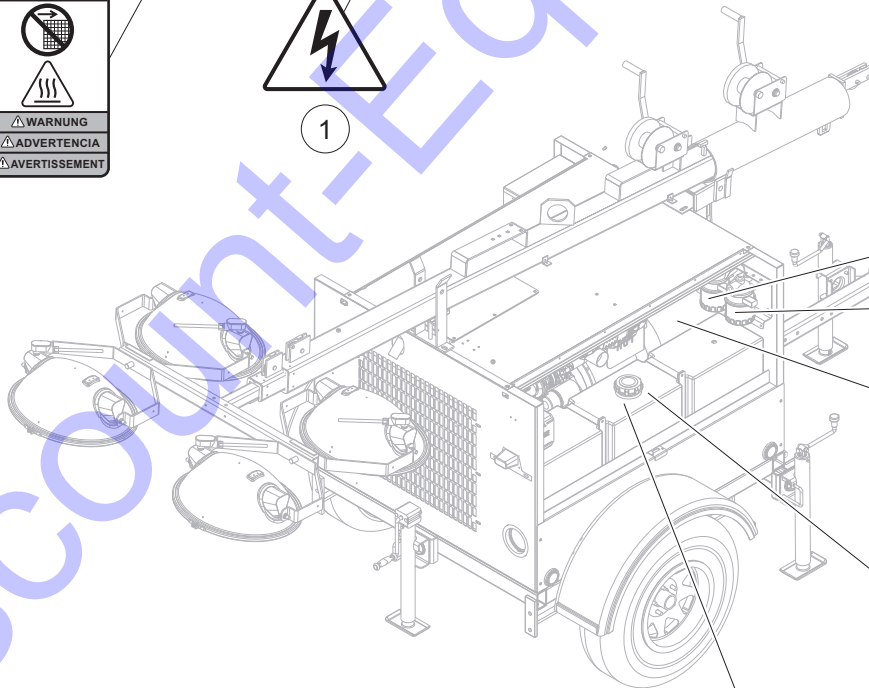

PRIMARY FILTER 1

SECONDARY FILTER 1

1

1

DIESEL

1

ULTRA LOW SULFUR FUEL ONLY

S≤15 mg/kg

01564

UNIT DECALS - RIGHT SIDE AND INTERIOR

Item	Part No.	Qty	Description	Notes
1	37223	1	Decal, safety	

Discount-Equipment.com

MAST, JUNCTION BOX AND LIGHTS TO UNIT

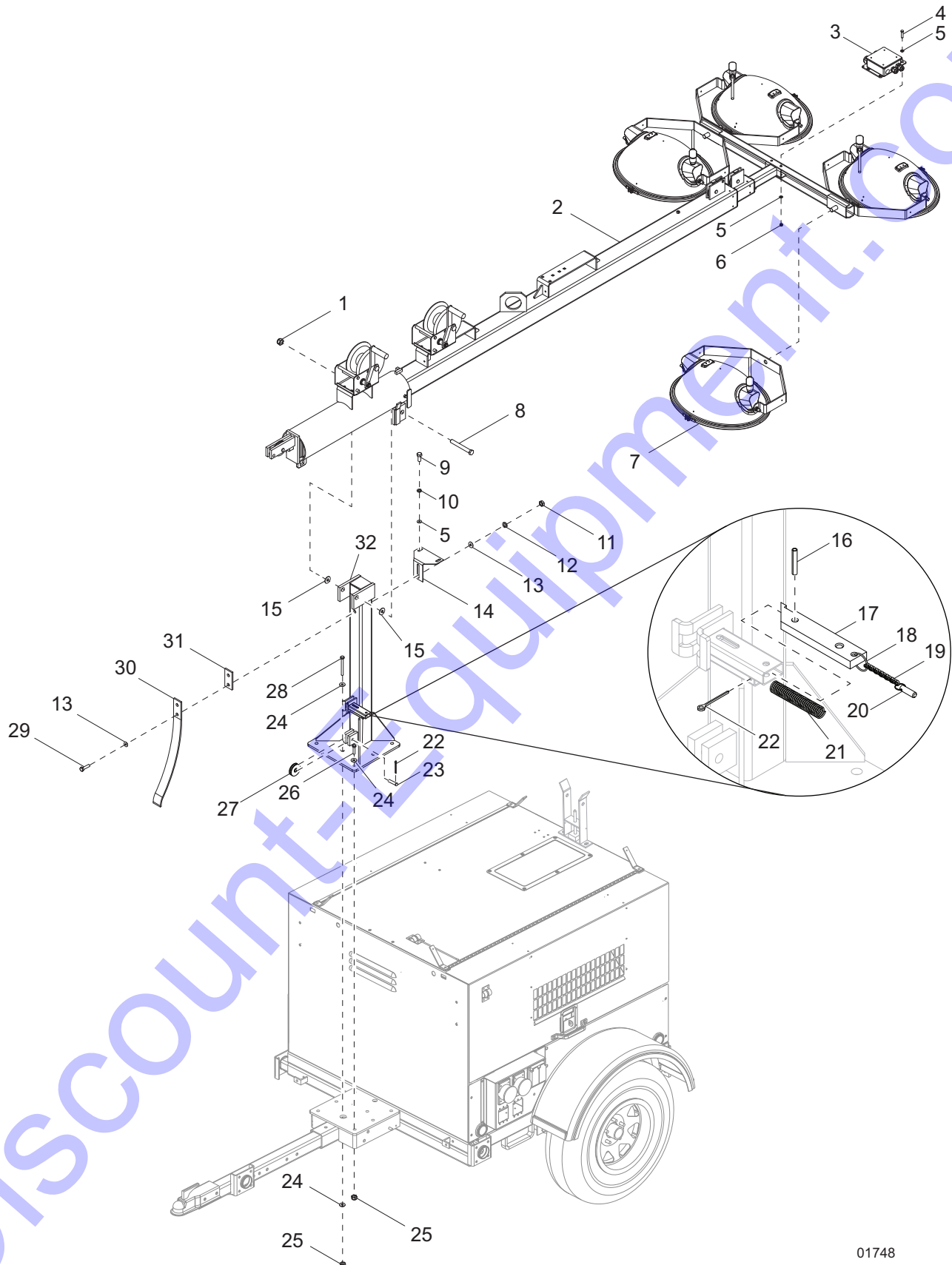

01748

MAST, JUNCTION BOX AND LIGHTS TO UNIT

Item	Part No.	Qty	Description	Notes
1	60584	1	Nut, .750-10 nylock, G5	
2	13536	1	Assembly, mast	
3	<i>Page 12</i>	1	Assembly, mast junction box	
4	60753	2	Screw, .375-16 x 3.50 std hex, SS	
5	60698	6	Washer, .375 flat .875/.040, SS	
6	60358	2	Nut, .375-16 nylock, G5	
7	<i>Page 10</i>	4	Assembly, light	
8	15292	1	Screw, .750-10 x 6.50 std hex, SS	
9	60690	2	Screw, .375-16 x 1.0 std hex, SS	
10	60703	2	Washer, .375 split lock, SS	
11	14229	2	Nut, .500-13 hex, G2	
12	60702	2	Washer, .500 split lock, SS	
13	60699	4	Washer, .500 flat 1.070/.080, SS	
14	13552B	1	Bracket, door adjustment	
15	60744	2	Washer, .750 flat 1.25/.060	
16	15165	1	Pin, roll - .250 x 1.25	
17	14663Z	1	Bar, latch	
18	60706	1	Ring, split - 1.0, SS	
19	60707	.58 ft	Chain, sash, SS	
20	14403	1	Pin, cotterless - .312 x 1.0	
21	14275	1	Spring, compression - .600 OD x 2.75 x .054	
22	15380	2	Pin, cotter - .125 x 1.25	
23	35655	1	Pin, clevis - .500 dia x 1.75	
24	60309	10	Washer, .500 flat 1.06/.090	
25	62221	8	Nut, .500-13 nylock, G5	
26	60683	6	Screw, .500-13 nylock, G5	
27	14261	1	Sheave - 2 in	
28	60659	2	Screw, .500-13 x 5.0 std hex, G5	
29	60732	2	Screw, .500-13 x 5.50 std hex, SS	
30	14845B	1	Spring, kick-back - 50 lb	
31	11554Z	1	Spacer plate - kick-back spring	
32	11057B	1	Weldment, mast post	
	11215	1	Assembly, latch bar	Items 17-20

LIGHT ASSEMBLY

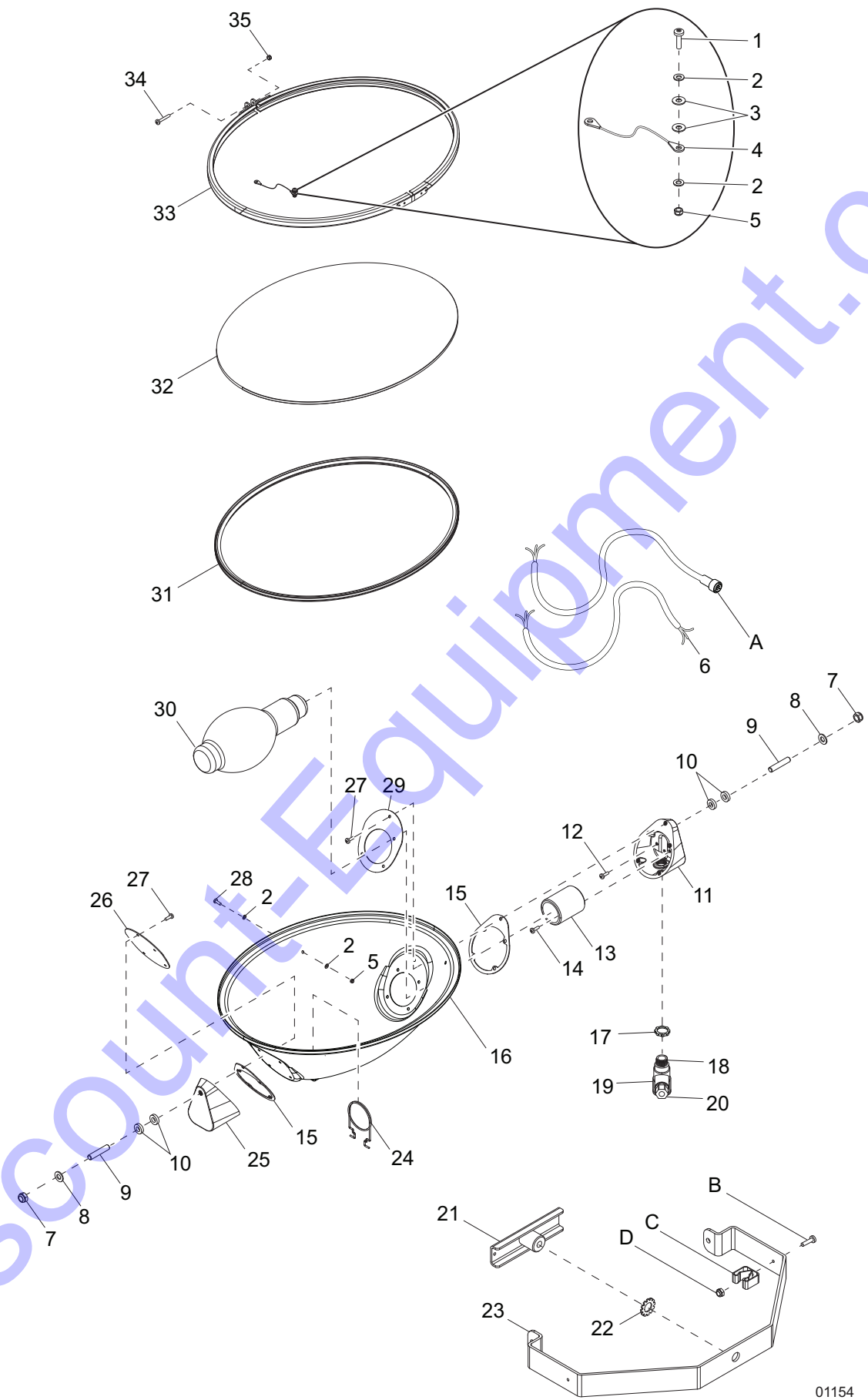

01154

LIGHT ASSEMBLY

Item	Part No.	Qty	Description	Notes
1	13399	1	Screw, M4 x 18 pan phil	
2	13371	4	Washer, #4	
3	13372	2	Washer, #4 nylon	
4	13370	1	Assembly, tether	
5	13395	2	Nut, M4 nylock	
6	13438	1	Cord, power - hard wired	
7	62221	2	Nut, .500-13 nylock, G5	
8	60247	2	Washer, .750 flat 2.020/.090	
9	13392	2	Stud, trunnion mounting	
10	13390	4	Washer, .500 nylon	
11	13375	1	Support, housing/trunnion w/cord	
12	13393	1	Screw, M5 x 12 phil	
13	13381	1	Socket, bulb w/out threaded insert	
14	13396	2	Screw, pan phil	
15	13378	2	Gasket, silicone	
16	13366	1	Housing assembly	
17	15861	1	Nut, special, .500NPT lock	
18	13386	1	Fitting, nipple - .500	
19	13387	1	Connector, weathertight - 500	
20	15864	1	Strain relief, .500NPT watertight, .270/.464 ID	
21	13403	1	Handle, T-wing nut	
22	61107	1	Washer, .500 external star	
23	13368	1	Trunnion	
24	13380	1	Bracket, bulb support	
25	13374	1	Support, housing/trunnion w/out cord	
26	13377	1	Bracket, non socket end plate	
27	13388	10	Screw, M5 x 12 flg hex, slotted	
28	13394	1	Screw, M4 x 10 pan phil	
29	13376	1	Bracket, socket end plate	
30	11391	1	Bulb, 1000W MH short length	
31	13373	1	Gasket, lens	
32	13369	1	Lens, glass	
33	13367	1	Assembly, aluminum ring	
34	13398	1	Screw, ground	
35	13397	1	Nut, nylock	
--	13311	1	Assembly, light - hard wired	Items 1-35

OPTIONAL FEATURES

Quick Disconnect Light:

A	13383	1	Cord, power quick disconnect	Replaces item 6
B	60398	1	Screw, 10-32 x .500 pan phil, SS	
C	19041	1	Clip, spring holder	
D	60061	1	Nut, 10-32 nylock	
--	13601	1	Assembly, light - quick disconnect, cord clip	

MAST JUNCTION BOX - HARD WIRED

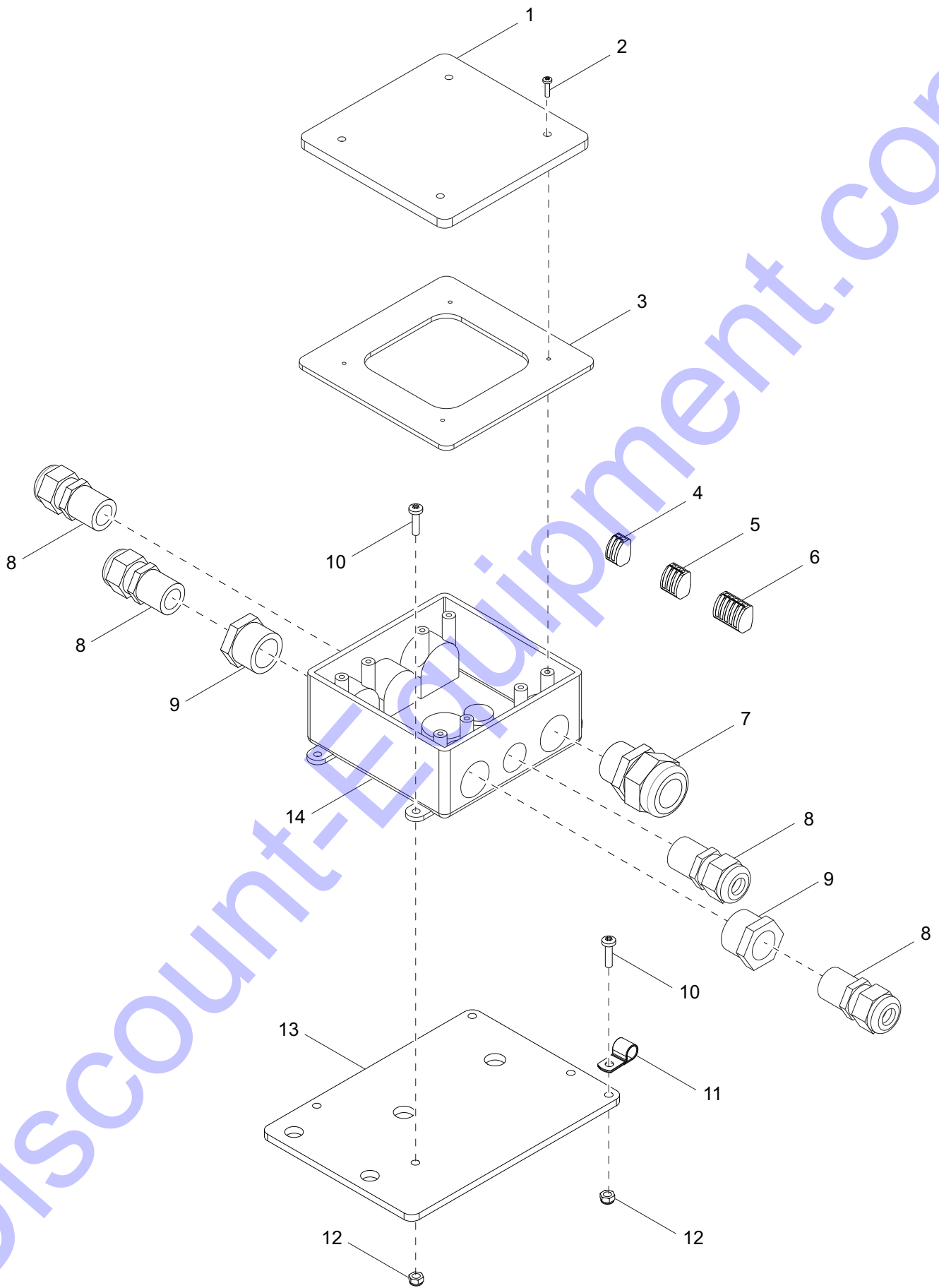

01155

MAST JUNCTION BOX - HARD WIRED

Item	Part No.	Qty	Description	Notes
1	12109	1	Cover, box, 2 gang plastic	
2	60424	4	Screw, 6-32 x .750 pan phil, G2, self thread	
3	13749	1	Gasket, junction box	
4	66100	4	Connector, 2 position	
5	66101	2	Connector, 3 position	
6	66102	1	Connector, 5 position	
7	15864	4	Strain relief - .500NPT watertight, .270/.464 ID	
8	14656	1	Strain relief - .750NPT watertight, .545/.709 ID	
9	60755	2	Fitting, strt - .750MNPT x .500FNPT, nylon	
10	60062	5	Screw, 10-32 x .750 pan phil, G2	
11	16143	1	Clamp, tubing - .500	
12	60415	5	Nut, 10-32 nylock, SS	
13	12095B	1	Bracket, junction box	
14	12094	1	Box, junction	
--	13614	1	Decal, mast junction box, wiring 4LT - new wago	
--	11789	1	Assembly, mast junction box - hard wired	Items 1-14

MAST JUNCTION BOX - QUICK DISCONNECT

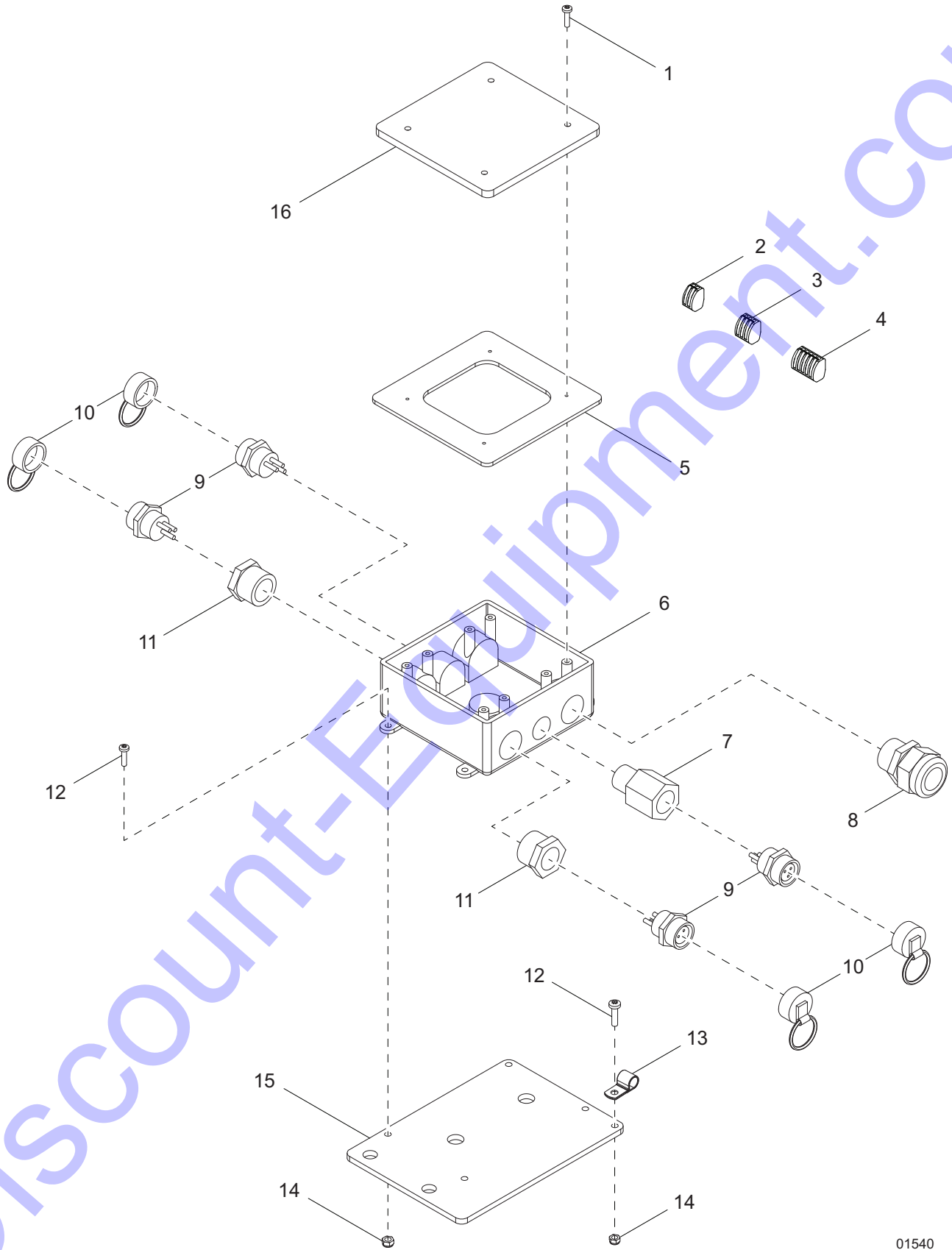

01540

MAST JUNCTION BOX - QUICK DISCONNECT

Item	Part No.	Qty	Description	Notes
1	60424	4	Screw, 6-32 x .750 pan phil, G2	
2	66100	4	Connector, 2 position	
3	66101	2	Connector, 3 position	
4	66102	1	Connector, 5 position	
5	13749	1	Gasket, junction box	
6	12094	1	Box, junction	
7	12713	1	Fitting, strt - .500MNPT x .500FNPT, steel	
8	14656	1	Strain relief - .750NPT, watertight	
9	15403	4	Connector, quick disconnect - female	
10	12410	4	Assembly, quick disconnect receptacle cap w/chain	
11	60755	2	Fitting, strt - .750MNPT x .500FNPT, nylon	
12	60062	5	Screw, 10-32 x .750 pan phil, G2	
13	16143	1	Clamp, tubing - .500	
14	60415	5	Nut, 10-32 nylock, SS	
15	12095B	1	Bracket, junction box	
16	12109	1	Cover, box, 2 gang plastic	
--	13614	1	Decal, mast junction box, wiring 4LT - new wago	--
--	11957	1	Assembly, mast junction box - quick disconnect	Items 1-16

MAST ASSEMBLY - MANUAL WINCH

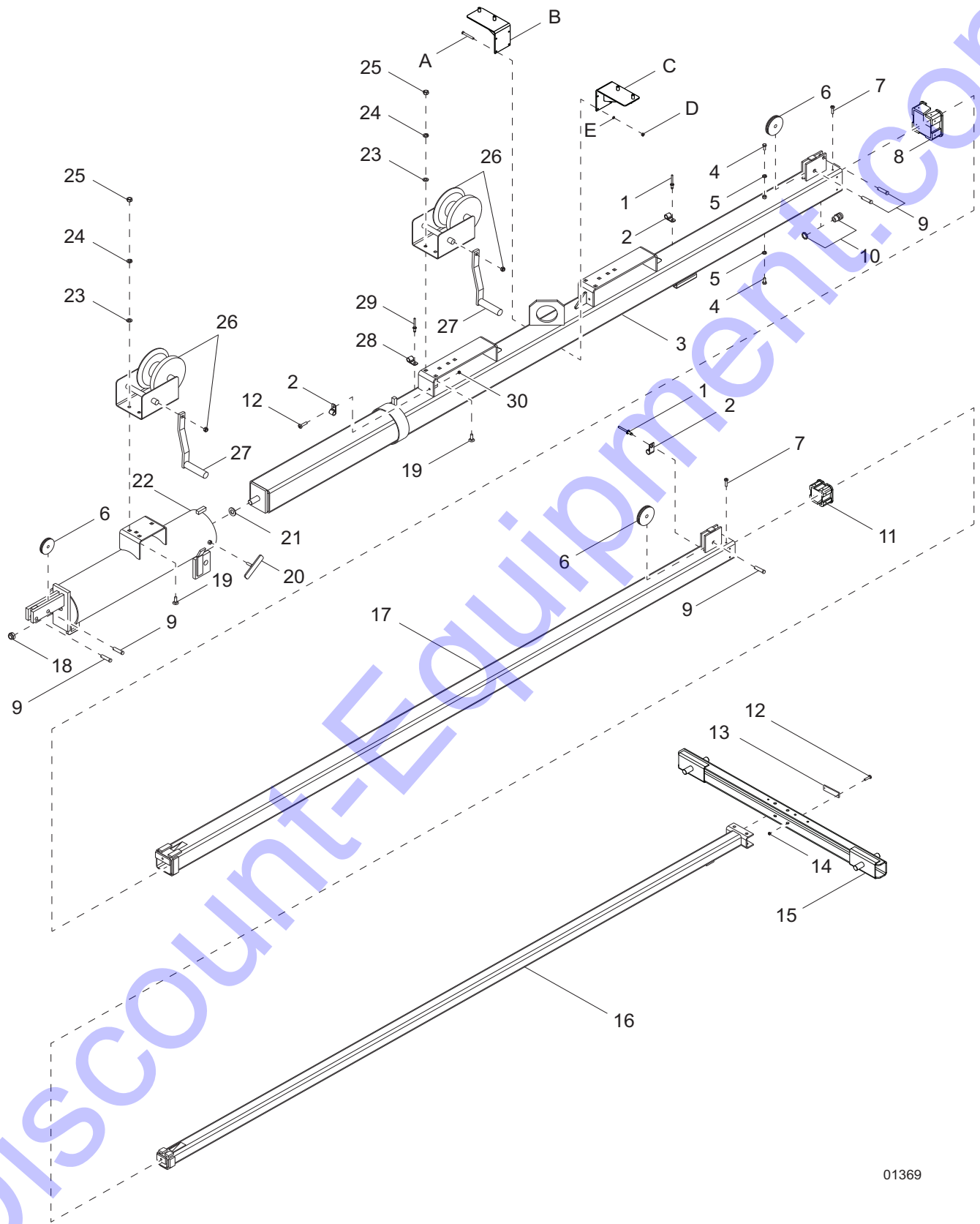

01369

MAST ASSEMBLY - MANUAL WINCH

Item	Part No.	Qty	Description	Notes
1	60268	2	Rivet, .188 dia x .126 to .250 grip	
2	16143	3	Clamp, tubing - .500	
3	11933B	1	Weldment, mast - 4.0 in	
4	60168	2	Screw, .312 x 18 x .750 std hex, G5	
5	60271	2	Washer, .312 split lock	
6	14262	3	Sheave 3.0 in	
7	32569	15	Screw, 8-16 x .375 pan phil, SS	
8	13790	1	Shim - 4x4 tube	
9	63325	5	Pin, clevis - .500 dia x 1.063	
10	14871	1	Strain relief - .500NPT, .500 cord	
11	13789	1	Shim - 3x3 tube	
12	60062	3	Screw, 10-32 x .750 pan phil, G2	
13	15829	1	Reflector - red	
14	60061	2	Nut, 10-32 nylock	
15	13527B	1	Weldment, mast crossbar	
16	16257B	1	Weldment, mast - 2.0 in	
17	11934B	1	Weldment, mast - 3.0 in	
18	60584	1	Nut, .750-10 nylock, G5	
19	60658	6	Screw, .375-16 x 1.0 carr sqr, G5	
20	11649Z	1	Weldment, T-bolt	
21	60247	1	Washer, .750 flat 2.020/.130	
22	11902B	1	Weldment, mast tube	
23	60698	6	Washer, .375 flat .875/.040, SS	
24	60206	6	Washer, .375 split lock	
25	60140	6	Nut, .375-16 hex, G5	
26	16600	2	Winch, manual - 1500 lb	Nut included
27	15623	2	Winch handle - 9.0 in	
28	15627	1	Clamp, tubing - .625 heavy duty	
29	60195	1	Rivet, .188 dia x .375 to .500 grip large flange	
30	60415	1	Nut, 10-32 nylock, SS	
--	15006	1	Cable - .188 in. x 27 ft steel w/ball swedge	Attaches to item 3
--	14151	1	Cable - .188 in. x 11 ft steel w/ball swedge	Attaches to item 17
--	14798	1	Cable - .188 in. x 16 ft steel w/teardrop	Attaches to item 22
--	11954	1	Cord, coil	
--	15002	2	Clip, wire rope - .188, single saddle	
--	15003	1	Thimble, cable - .188	
OPTIONAL FEATURES				
<i>Mast Light Storage:</i>				
A	60780	4	Screw, .375-16 x 5.5 std hex, G5	
B	13689B	1	Weldment, oval light storage - RH	
C	13870B	1	Weldment, oval light storage - LH	
D	60679	4	Nut, .375-16 hex, SS	
E	60703	4	Washer, .375 split lock, SS	
<i>Drape Cord:</i>				
--	14128	1	Cord, drape - 33 ft	Replaces coil cord

MAST ASSEMBLY - ELECTRIC WINCH (PRIOR TO 9-29-2015)

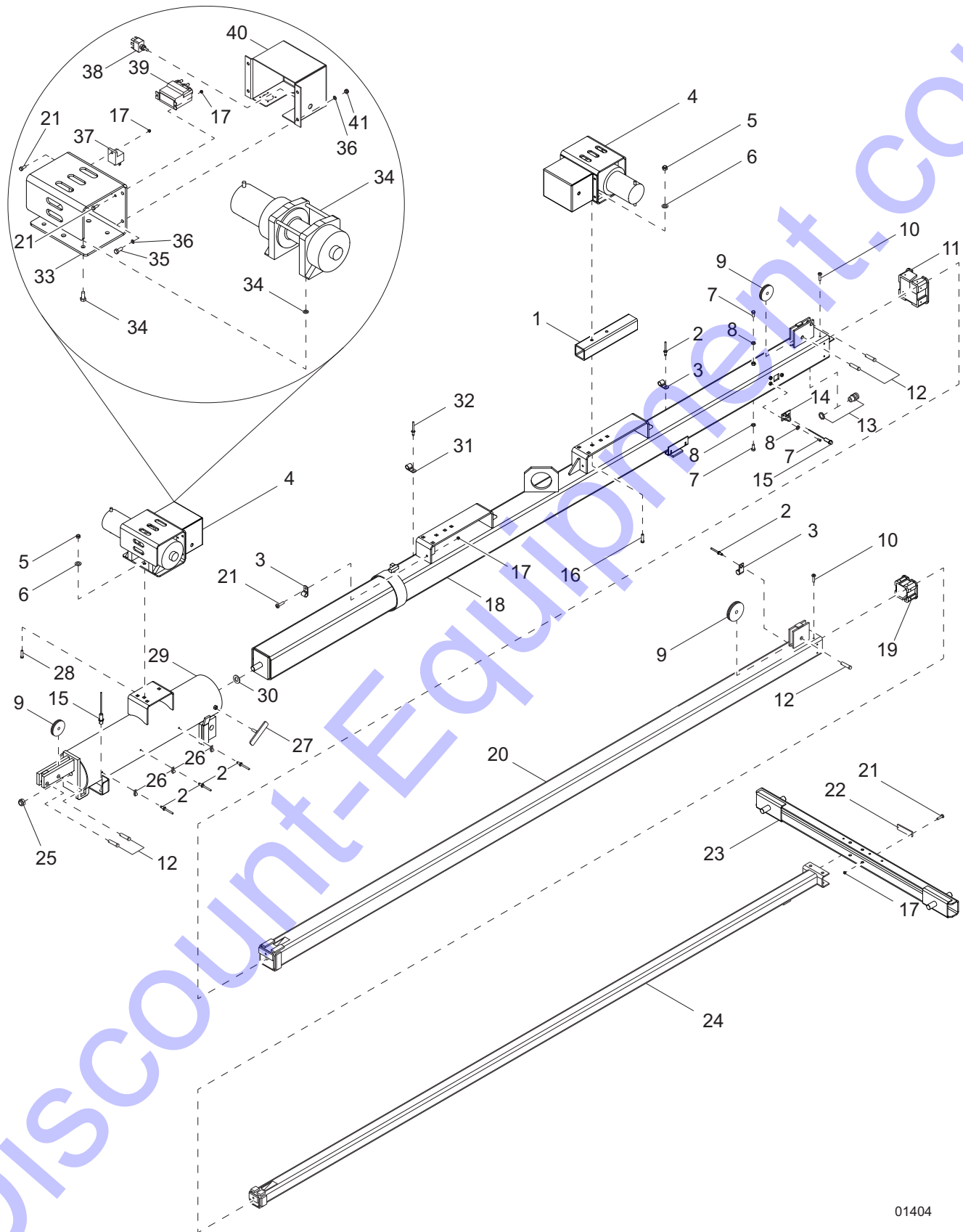

01404

MAST ASSEMBLY - ELECTRIC WINCH (PRIOR TO 9-29-2015)

Item	Part No.	Qty	Description	Notes
1	11967B	1	Tube, mount	
2	60268	5	Rivet, .188 dia x .126 to .250 grip, SS	
3	16143	3	Clamp, tubing, .500	
4	10649	2	Assembly, electric winch	
5	60358	4	Nut, .375-16 nylock, G5	
6	60386	4	Washer, .375 flat .993/.064	
7	60168	5	Screw, .312-18 x 7.50 std hex, G5	
8	60271	5	Washer, .312 split lock	
9	14262	3	Sheave - 3 in	
10	32569	15	Screw, 8-16 x .375 pan phil, SS	
11	13790	1	Shim - 4x4 tube	
12	35655	5	Pin, clevis - .500 dia x 1.75	
13	14871	1	Strain relief - .500NPT, .500 cord	
14	13796B	1	Weldment, proximity sensor bracket	
15	65511	2	Sensor, proximity	
16	60991	2	Screw, .375-16 x 3.0 carr sqr, G5	
17	60061	5	Nut, 10-32 nylock	
18	12085B	1	Weldment, mast - 4.0	
19	13789	1	Shim - 3x3 tube	
20	12084B	1	Weldment, mast - 3.0	
21	60062	9	Screw, 10-32 x .750 pan phil, G2	
22	15829	1	Reflector, red	
23	13527B	1	Weldment, mast crossbar	
24	16257B	1	Weldment, mast - 2.0	
25	60584	1	Nut, .750-10 nylock, G5	
26	60375	3	Clamp, tubing - .312	
27	11649Z	1	Weldment, T-bolt	
28	60658	2	Screw, .375-16 x 1.0 carr sqr, G5	
29	12876B	1	Weldment, mast tube	
30	60247	1	Washer, .750 flat 2.02/.130	
31	15627	1	Clamp, tubing - .625	
32	60195	1	Rivet, .188 dia x .375 to .500 grip, large flange	
33	12872B	2	Bracket, winch mounting	
34	12874	2	Winch, electric - 770 lb hoist	Hardware included
35	60281	8	Screw, .250-20 x .750 std hex, G5	
36	60243	16	Washer, .250 flat .735/.060	
37	65049	2	Relay, 12V 30/40A NO w/diode	
38	65707	2	Switch, toggle - SPDT, spring weatherproof	
39	11293	2	Contact, 12V	
40	12875B	2	Cover, winch contactor	
41	60144	8	Nut, .250-20 nylock, G5	
--	35845	1	Wire group, electric winch	
--	66819	1	Wire group, electric winch cables	
--	12922	4	Boot, battery cable	
--	15006	1	Cable - .188 in. x 27 ft steel w/ball swedge	Attaches to item 18
--	14798	1	Cable - .188 in. x 16 ft steel w/teardrop	Attaches to item 29
--	14151	1	Cable - .188 in. x 11 ft steel w/ball swedge	Attaches to item 20
--	15003	1	Thimble, cable - .188	
--	15002	1	Clip, wire rope -.188, single saddle	
--	11954	1	Cord, coil	

ROOF AND DOORS TO UNIT

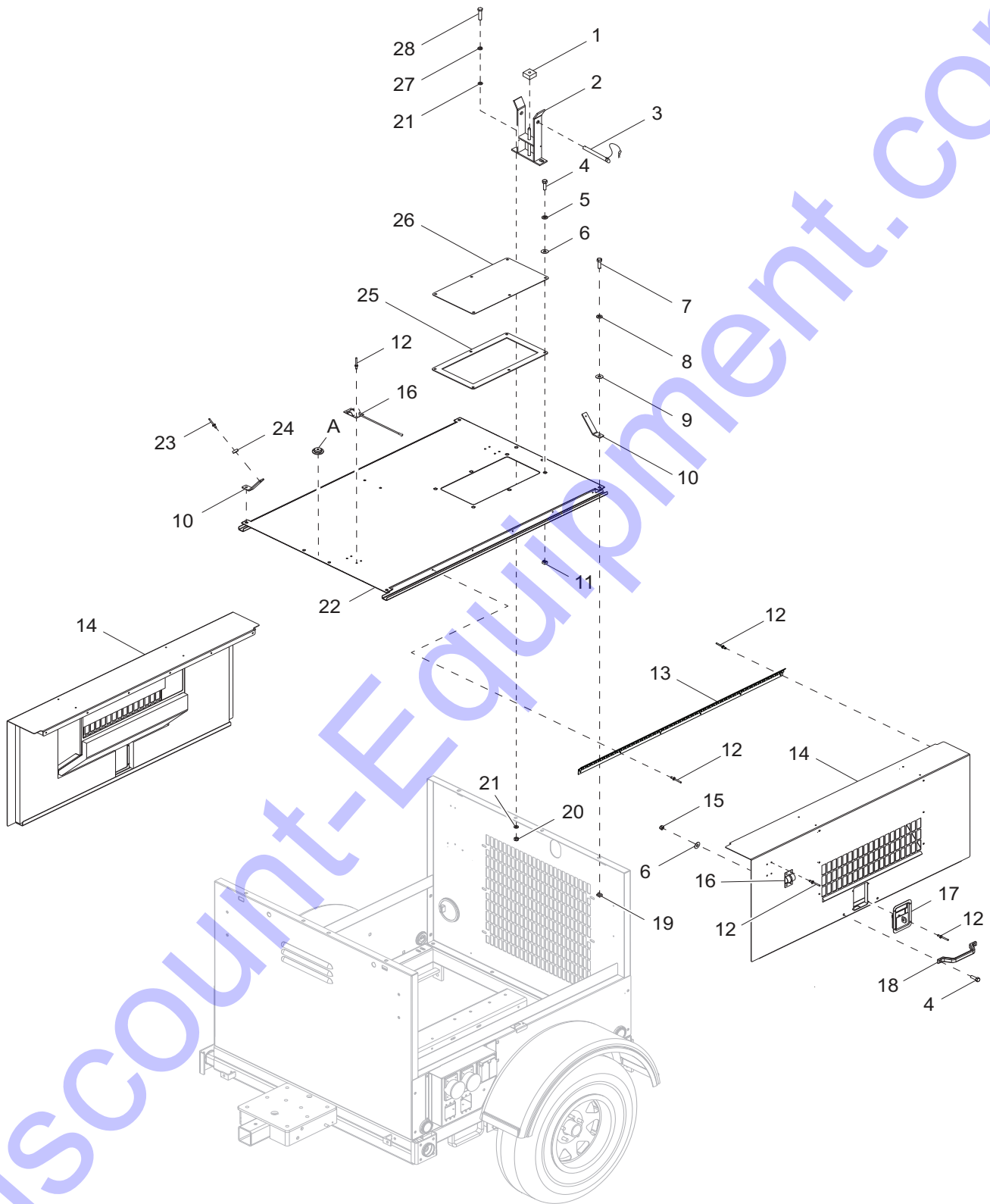

01567

ROOF AND DOORS TO UNIT

Item	Part No.	Qty	Description	Notes
1	11935	1	Pad, rubber - 2.0 X 2.0 X 1.0	
2	12344ZN	1	Weldment, cradle	
3	16099	1	Assy, cradle pin	
4	60507	14	Screw, .312-18 x 1.0 std hex, SS	
5	60341	6	Washer, M8 split lock, SS	
6	60340	10	Washer, .312 flat .875/.040, SS	
7	60690	4	Screw, .375-16 x 1.0 std hex, SS	
8	60703	4	Washer, .375 split lock, SS	
9	60698	4	Washer, .375 flat .875/.040, SS	
10	62779B	4	Bracket, door stop	
11	15425	6	Nut, .312-18 cage	
12	60268	48	Rivet, .188 dia x .126 to .250 grip	
13	16598	2	Hinge, door	
14	Page 22	2	Assembly, door	
15	60303	4	Nut, .312-18 nylock, G2	
16	62278	2	Latch, door	
17	15123	2	Latch, paddle w/7 lb spring	
18	26288	2	Handle, front access	
19	60657	4	Nut, .375-16 cage, G5	
20	14229	2	Nut, .500-13 hex, G2	
21	60699	4	Washer, .500 flat 1.070/.080, SS	
22	35969W	1	Panel, roof	
23	60863	4	Rivet, .156 dia x .251 to .375 grip	
24	15215	4	Bumper, rubber	
25	12195	1	Gasket, back access panel	
26	25333W	1	Panel, back access	
27	60702	2	Washer, .500 split lock, SS	
28	60683	2	Screw, .500-13 x 1.50 std hex, SS	

OPTIONAL FEATURES

Level Eye:

A	14433	1	Level, eye
---	-------	---	------------

DOOR ASSEMBLY

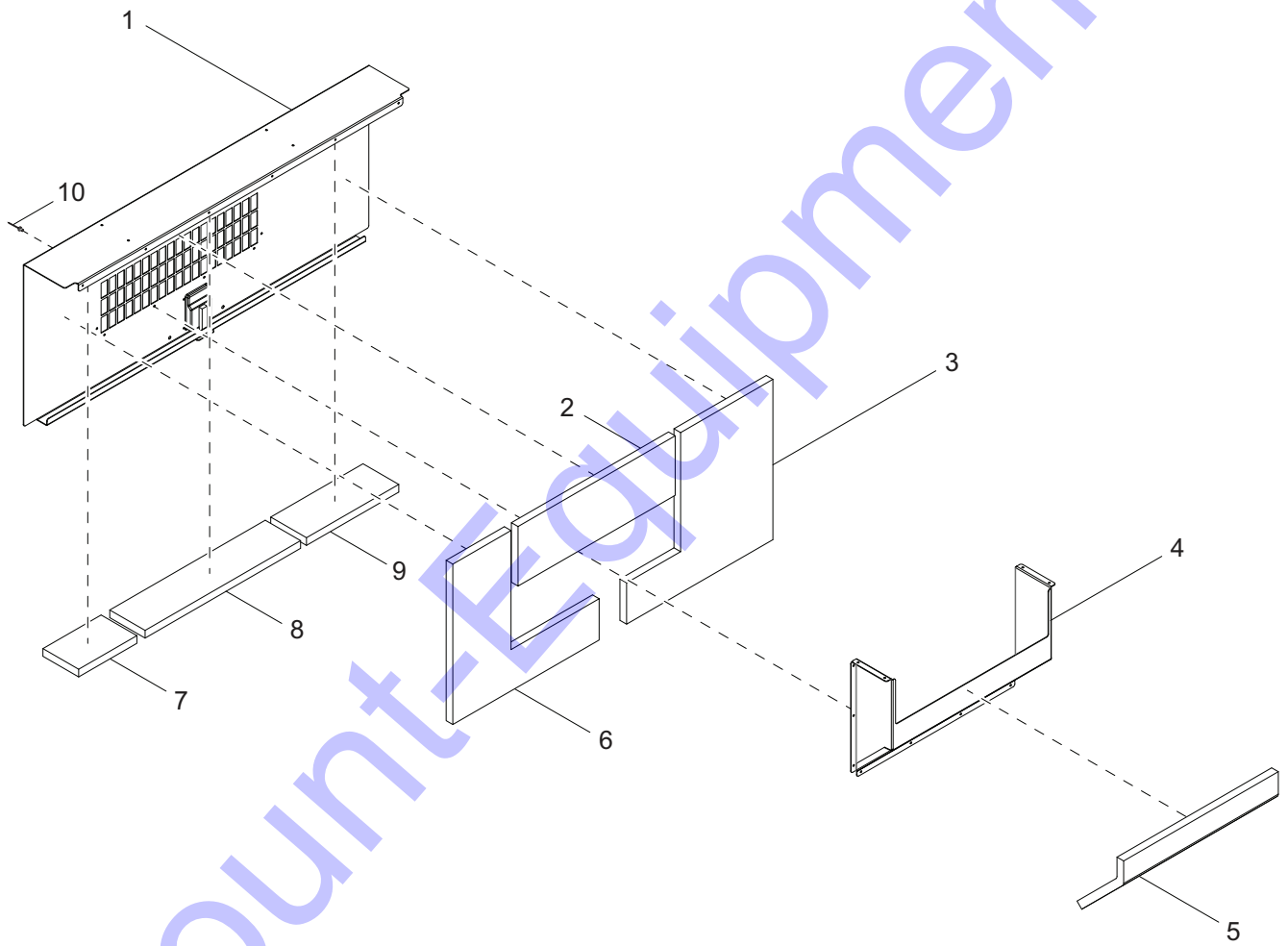

01568

DOOR ASSEMBLY

Item	Part No.	Qty	Description	Notes
1	37122W	1	Panel, door	
2	37437	1	Foam, door - grate	
3	37433	1	Foam, door - right	
4	31379W	1	Duct, door	
5	37438	1	Foam, door - duct	
6	37432	1	Foam, door - left	
7	37434	1	Foam, door - top left	
8	37436	1	Foam, door - top middle	
9	37435	1	Foam, door - top right	
10	60268	14	Rivet, .188 dia x .126 to .250 grip	

FRONT, REAR AND SIDE PANELS TO UNIT

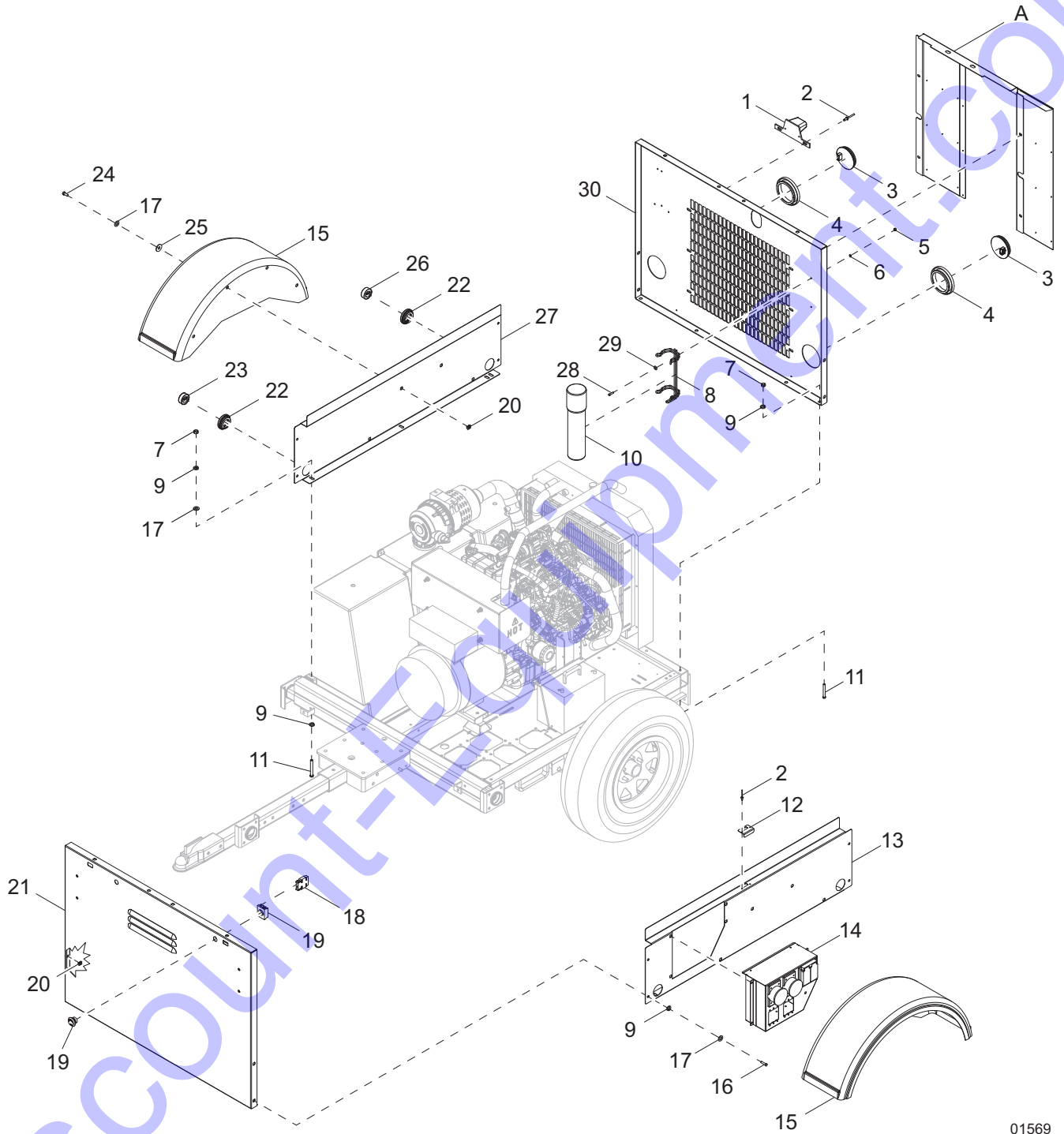

01569

FRONT, REAR AND SIDE PANELS TO UNIT

Item	Part No.	Qty	Description	Notes
1	10223	1	Assembly, license plate holder	
2	60423	6	Rivet, .188 dia x .250 to .375 grip	
3	66701	2	Light, rear tail/turn, round 4.0 in., no grommet - LED	
4	10221	2	Grommet, rear light, rubber 4.50 in	
5	60038	2	Nut, M5-.80 nylock	
6	60067	2	Washer, #10 flat .435/.060, SS	
7	60140	10	Nut, .375-16 std hex, G5	
8	11222	1	Bracket, manual holder	
9	60698	18	Washer, .375 flat .875/.040, SS	
10	11121	1	Manual holder tube	
11	60689	10	Screw, .375-16 x 4.0 std hex, SS	
12	13291	2	Plate, striker	
13	35957W	1	Panel, left side	
14	Page 26	1	Assembly, receptacle panel	
15	11381	2	Fender, plastic - 14 in	
16	60690	8	Screw, .375-16 x 1.0 std hex, SS	
17	60703	16	Washer, .375 split lock, SS	
18	65472	1	Block, E-stop contactor - NC/NO	
19	65470	1	Switch, E-stop	
20	60657	32	Nut, .375-16 cage, G5	
21	37070W	1	Panel, front	
22	66394	4	Grommet, sealed beam light	
23	66702	2	Light, clearance, 2.0 in., no grommet - amber LED	
24	60295	8	Screw, .375-16 x .750 std hex, SS	
25	60386	8	Washer, .375 flat .993/.064	
26	66703	2	Light, clearance, 2.0 in., no grommet - red LED	
27	35958W	1	Panel, right side	
28	60446	2	Screw, M5-.80 x 20 pan phil, SS	
29	60089	2	Washer, .265 fender 1.250/.060	
30	35971W	1	Panel, rear	

OPTIONAL FEATURES

Silent Pack:

A	35970W	1	Duct, rear
---	--------	---	------------

RECEPTACLE BOX ASSEMBLY

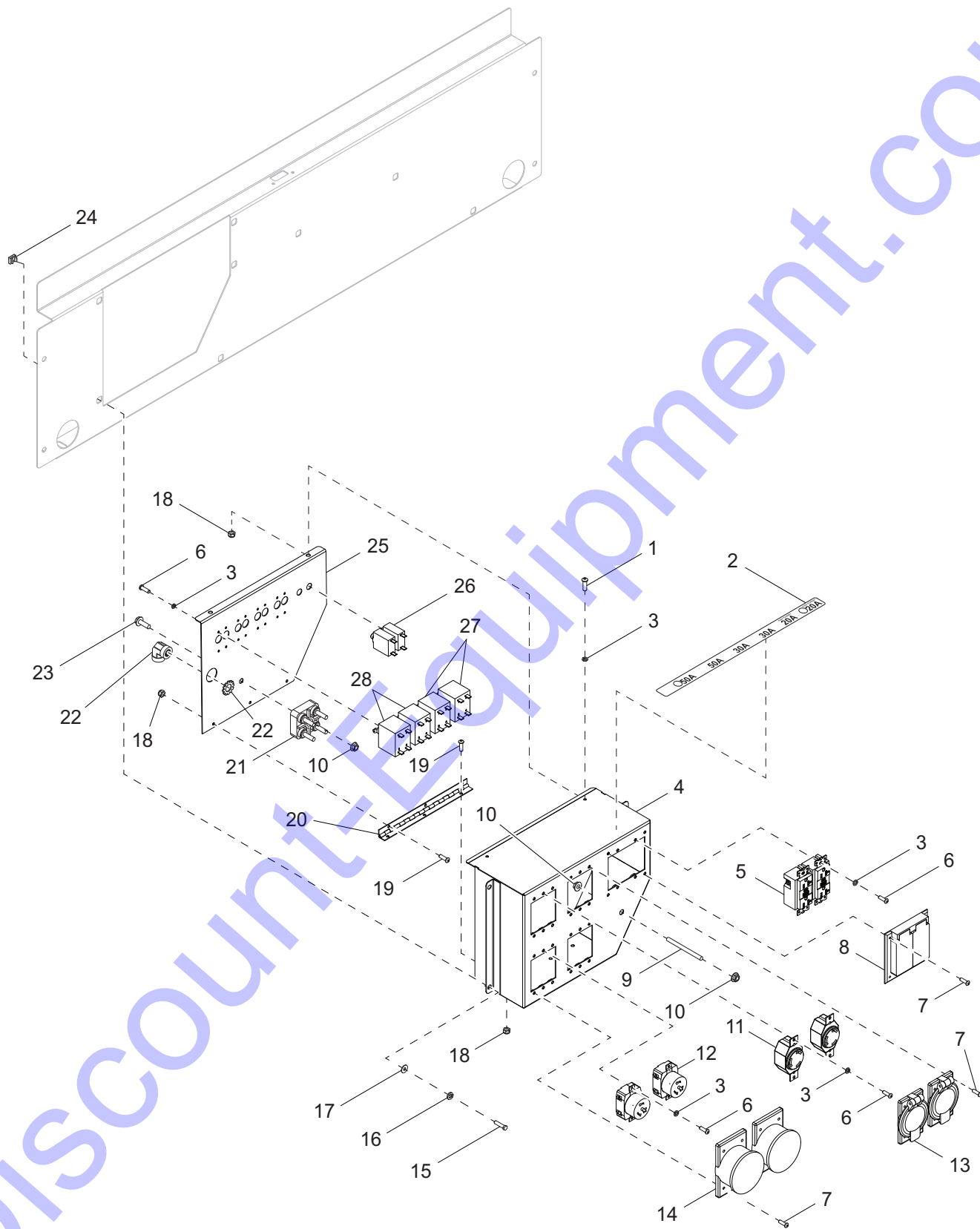

01836

RECEPTACLE BOX ASSEMBLY

Item	Part No.	Qty	Description	Notes
1	60037	2	Screw, M5-.80 x 20 pan phil, G4.8	
2	10792	1	Decal, aux breakers - 50,50,30,30,20,20	
3	60058	30	Washer, #6 split lock	
4	10783W	1	Weldment, receptacle box	
5	14130	2	Receptacle, 120V/20A GFI (5-20R)	
6	60405	28	Screw, 6-32 x .250 pan phil, G2	
7	60770	20	Screw, M4-.70 x 20 pan phil, G4.8	
8	15849	1	Cover, receptacle - 20A GFCI dual	
9	18992	1	Stud, ground	
10	60020	3	Nut, M8-1.25 sflg, G8.8	
11	14137	2	Receptacle, 240V/30A twist (L6-30R)	
12	18089	2	Receptacle, 240V/50A twist-lock	
13	65460	2	Cover, receptacle - 20/30A twist-lock	
14	65467	2	Cover, receptacle - 50A twist (deep)	
15	60507	4	Screw, .312-18 x 1.0 std hex, SS	
16	60341	4	Washer, M8 split lock, SS	
17	60340	4	Washer, .312 flat .875/.040, SS	
18	60038	8	Nut, M5-.80 nylock	
19	60044	6	Screw, M5-.80 x 12 pan phil, G4.8	
20	10784	1	Hinge, piano - 9 in	
21	65519	1	Block, terminal - 4 pole stud type	
22	65535	1	Clamp, 90 degree 3/4 in	
23	60160	1	Screw, M8-1.25 x 30 sflg hex, G8.8	
24	15425	4	Nut, .312-18 cage	
25	10771W	1	Panel, outlet	
26	65849	2	Breaker, 20A, 120V, 1-pole, push button	
27	66097	2	Breaker, 30A, 250V, 2-pole, 1 lever	
28	65492	2	Breaker, 50A, 250V, 2-pole w/aux	
29	10393	1	Assembly, receptacle box	Items 1-28

RECEPTACLE PANEL OPTIONS

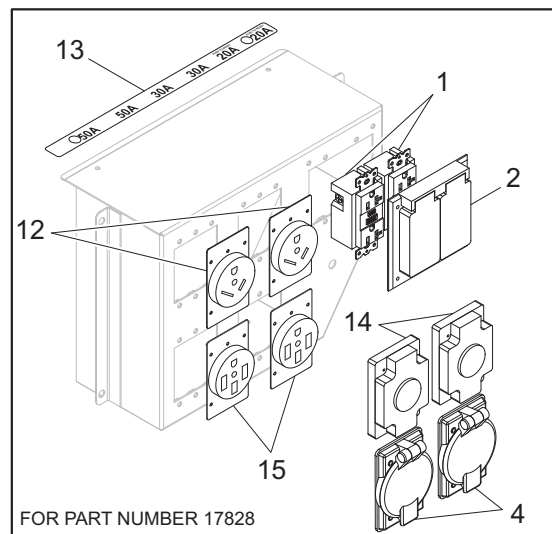
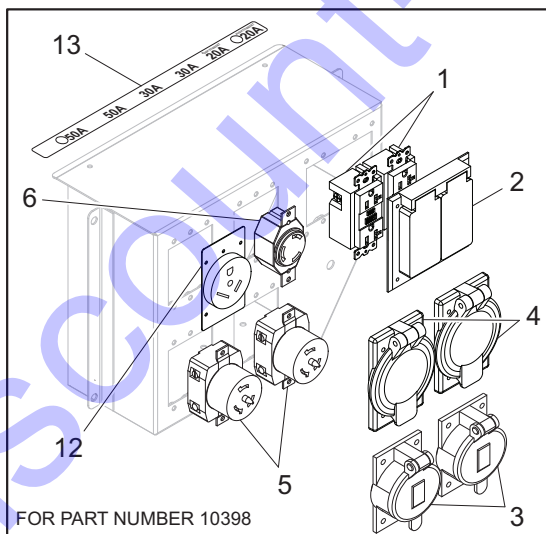
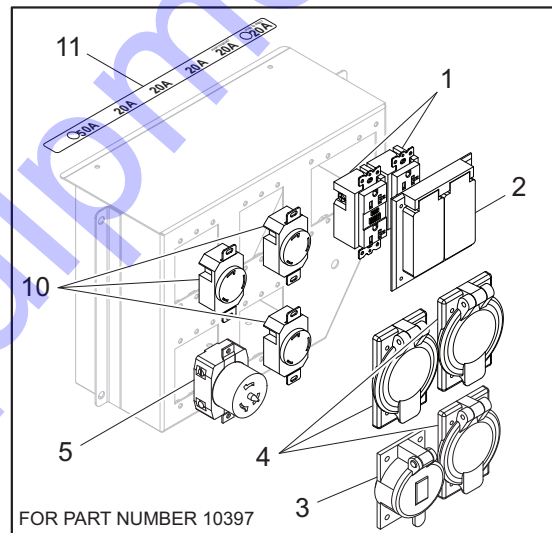
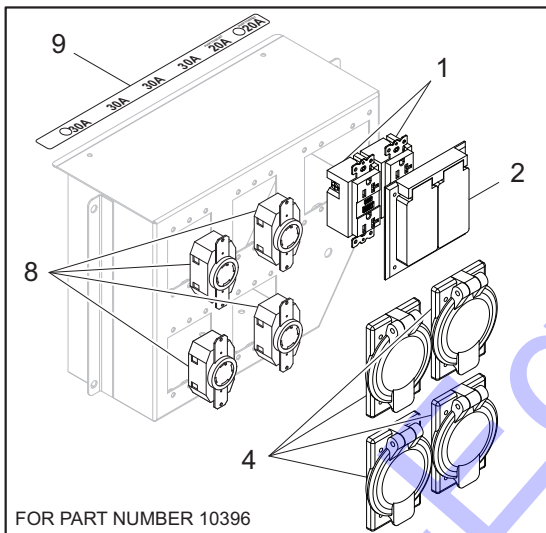
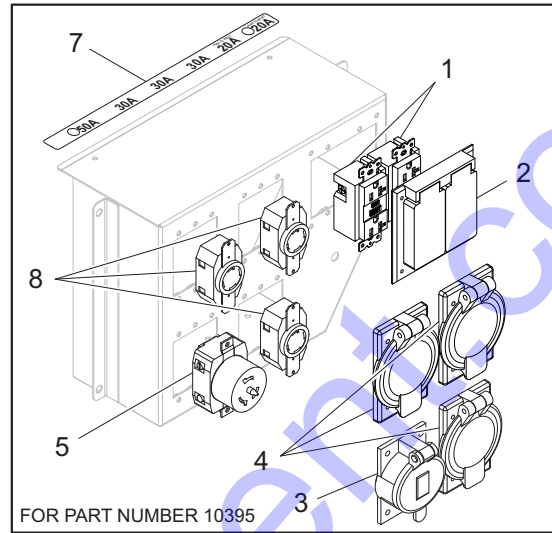
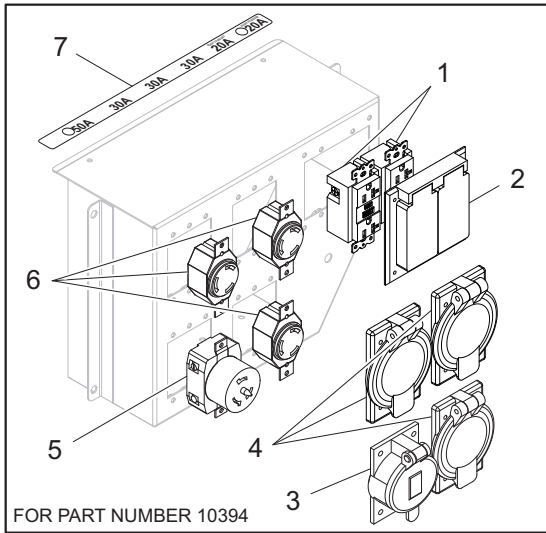

01759

RECEPTACLE PANEL OPTIONS

Item	Part No.	Qty	Description	Notes
1	14130	12	Receptacle, 120V/20A GFI (5-20R)	
2	15849	6	Cover, receptacle - 20A GFCI dual	
3	65467	5	Cover, receptacle - 50A twist (deep)	
4	65460	15	Cover, receptacle 20/30A twist-lock	
5	18089	5	Receptacle, 240V/50A twist-lock	
6	14137	4	Receptacle, 240V/30A twist (L6-30R)	
7	17638	1	Decal, aux breakers - 50,30,30,30,20,20	
8	65488	7	Receptacle, 240V/30A twist (L14-30R)	
9	17639	1	Decal, aux breakers - 30,30,30,30,20,20	
10	15933	3	Receptacle, 240V/20A twist (L6-20R)	
11	17640	1	Decal, aux breakers - 50,20,20,20,20,20	
12	65489	3	Receptacle, 120V/30A (TT-30R)(RV)	
13	10792	1	Decal, aux breakers - 50,50,30,30,20,20	
14	66955	2	Cover, receptacle 20/30A twist-lock	
15	65815	2	Receptacle, 240V/50A RV (14-50R)	

CONTROL BOX AND FUEL SYSTEM TO UNIT

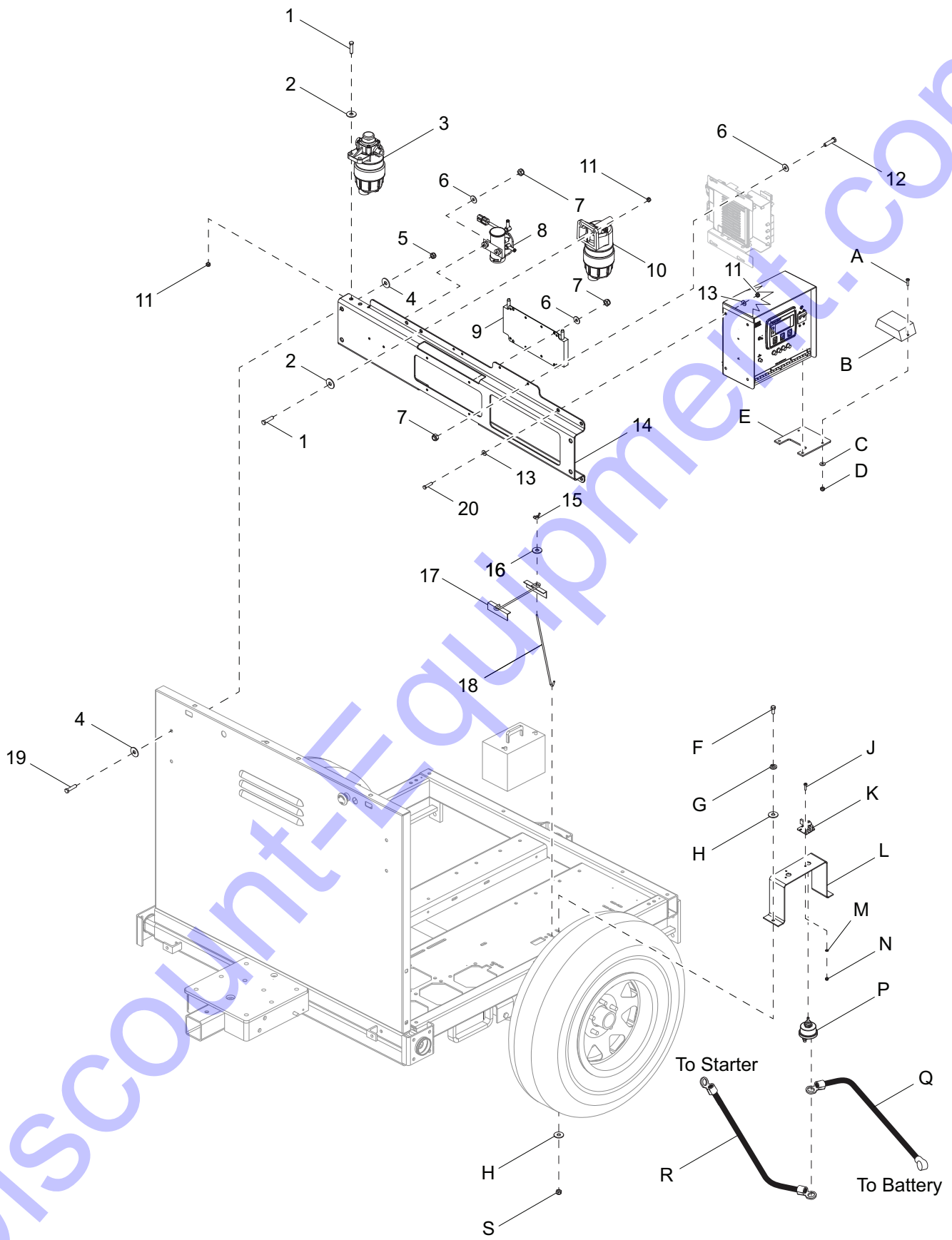

01573

CONTROL BOX AND FUEL SYSTEM TO UNIT

Item	Part No.	Qty	Description	Notes
1	60256	4	Screw, .312-18 x 1.50 std hex, G5	
2	60119	4	Washer, .312 flat .875/.070	
3	33763	1	Isuzu, fuel filter - final	
4	60698	8	Washer, .375 flat .875/.040, SS	
5	60792	4	Nut, .375-16 nylock, SS	
6	60243	8	Washer, .250 flat .735/.060	
7	60144	8	Nut, .250-20 nylock, G5	
8	33764	1	Isuzu, fuel pump	
9	35898	1	Cooler, fuel	
10	33762	1	Isuzu, fuel filter - primary	
11	60303	8	Nut, .312-18 nylock, G2	
12	60281	4	Screw, .250-20 x .750 std hex, G5	
13	60340	8	Washer, .312 flat .875/.040, SS	
14	37130B	1	Assembly, bracket, fuel pump/filter	
15	60090	2	Nut, .250-20 wing, G5	
16	60089	2	Washer, .265 fender 1.25/.060	
17	14682	1	Bracket, battery hold down	
18	60820	2	Bolt, J - .250-20 x 9.0	
19	62247	4	Screw, .375-16 x .625 std hex, SS	
20	62043	4	Screw, .312-18 x 2.25 std hex, SS	

OPTIONAL FEATURES

Battery Charger:

A	60446	2	Screw, M5-.80 x 20 pan phil, SS
B	65326	1	Charger, battery - 2A, 3 stage, 1 output
C	60067	2	Washer, #10 flat .435/.060, SS
D	60038	2	Nut, M5-.80, nylock
E	12429B	1	Bracket, battery charger - 2 amp, 3 stage

Battery Disconnect:

F	60028	2	Screw, .312-18 x 1.0 std hex, G5
G	60271	2	Washer, .312 split lock
H	60119	2	Washer, .312 flat .875/.070
J	60277	2	Screw, 10-32 x .500 pan phil, G2
K	65499	1	Assembly, switch lockout lever
L	13654B	1	Bracket, battery disconnect
M	60067	2	Washer, #10 flat .435/.060, SS
N	60061	2	Nut, 10-32 nylock
P	65498	1	Switch, disconnect
Q	25075	1	Cable, battery - 24 in, 4GA red w/boot, .375 lug
R	15076	1	Cable, battery - 46 in, 4GA red, .375 lug
S	60303	2	Nut, .312-18 nylock, G2

FUEL FILTER HOSES

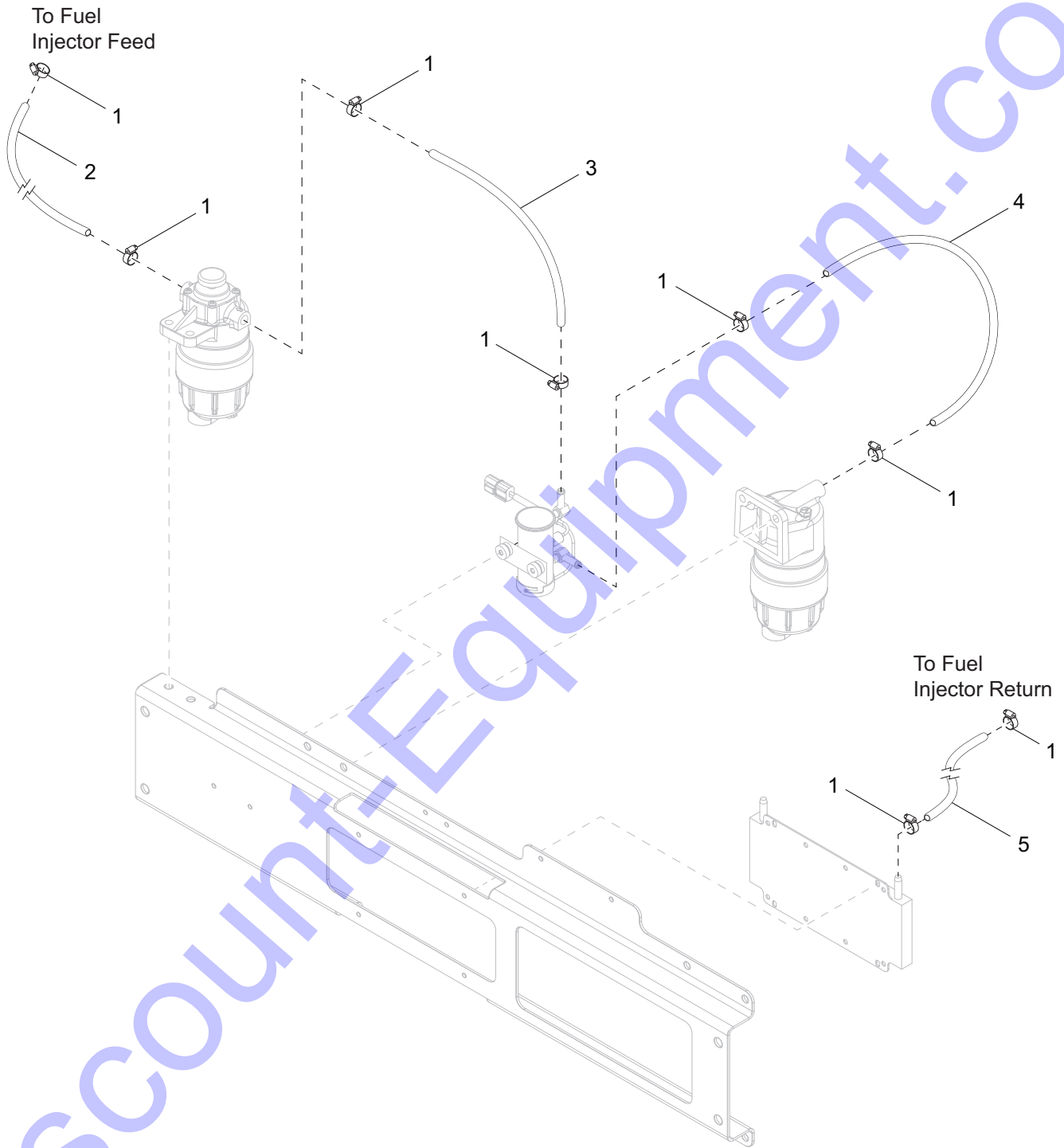

01878

FUEL FILTER HOSES

Item	Part No.	Qty	Description	Notes
1	60365	8	Clamp, hose - SAE 010 (.56-1.06)	
2	50051	9.75 ft	Hose, fuel - .375 ID, 50 psi, SAE 30R7	
3	50051	1.5 ft	Hose, fuel - .375 ID, 50 psi, SAE 30R7	
4	50051	1.75 ft	Hose, fuel - .375 ID, 50 psi, SAE 30R7	
5	50051	8.75 ft	Hose, fuel - .375 ID, 50 psi, SAE 30R7	

Discount-Equipment.com

CONTROL BOX ASSEMBLY

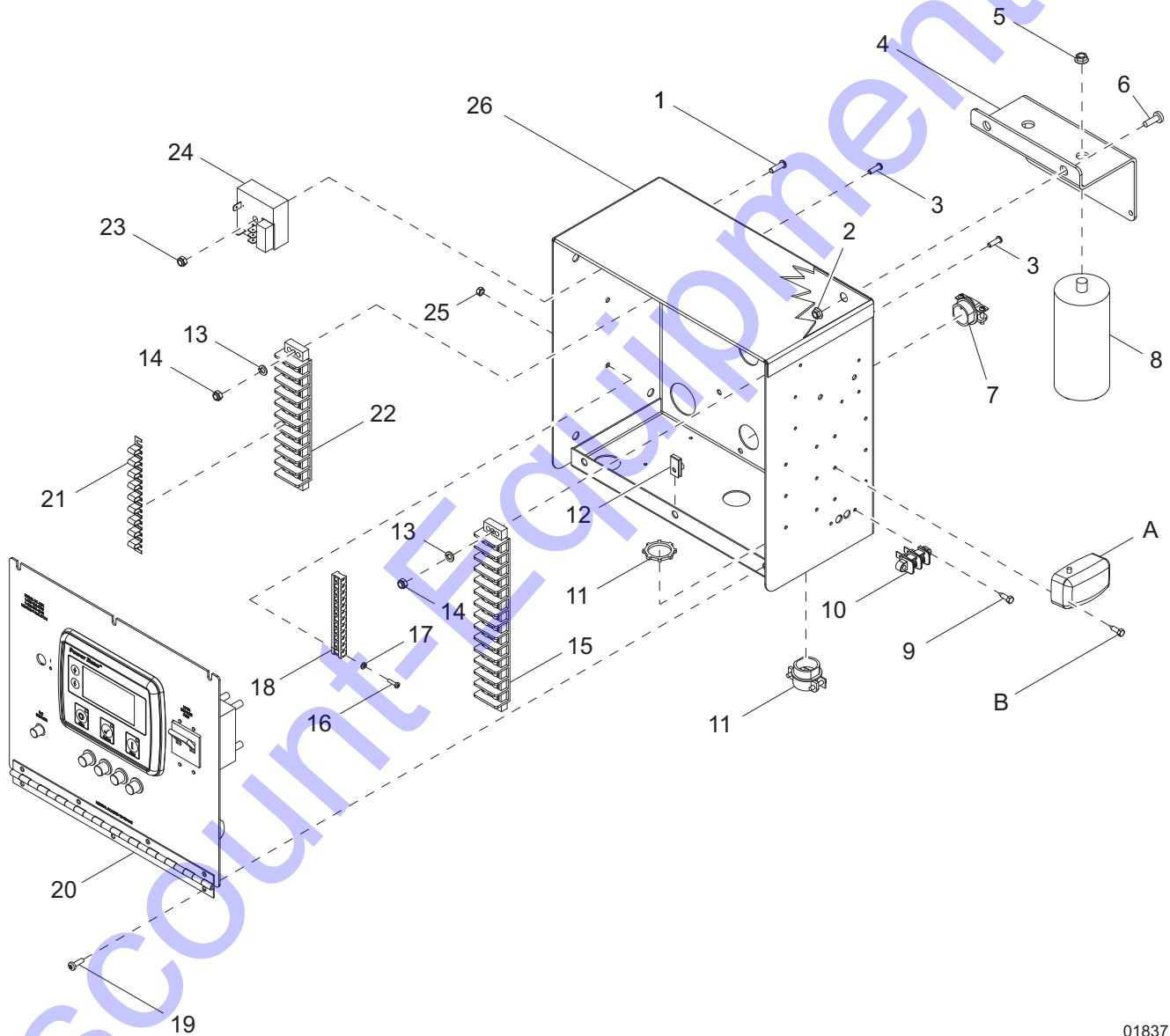

01837

CONTROL BOX ASSEMBLY

Item	Part No.	Qty	Description	Notes
1	60396	1	Screw, 10-32 x 1.25 pan phil, G2	
2	61045	2	Nut, 10-32 sflg	
3	60406	4	Screw, 8-32 x 1.0 pan phil, SS	
4	13343B	1	Bracket, dual capacitor mount - black	
5	60148	2	Nut, M12-1.75 sflg, G8.8	
6	60398	2	Screw, 10-32 x .500 pan phil, SS	
7	65490	1	Strain relief - 1.0 Romex w/nut	
8	65959	2	Capacitor, dual 24 μ F sealed, stud mount	
9	60488	2	Screw, 8-32 x .750 pan phil, G2, self-tapping	
10	68080	1	Block, terminal - 2 pos, feed thru	
11	14219	4	Strain relief - .750 Romex w/nut	
12	63105	6	Nut, 8-32 U-clip, G5	
13	60236	4	Washer, #8 split lock	
14	60270	4	Nut, 8-32 nylock	
15	66013	1	Terminal block, 14 pos, 30A, 600V, #8 screw	
16	60062	3	Screw, 10-32 x .750 pan phil, G2	
17	60252	3	Washer, #10 split lock	
18	14204	1	Kit, ground bar	
19	60526	6	Screw, 8-32 x .500 pan phil, G2	
20	Page 36	1	Assembly, control panel	
21	15125	1	Jumper	
22	14203	1	Block, terminal - 10 pos, 30A, 600V, #8 screw	
23	60061	1	Nut, 10-32 nylock	
24	29759	1	Relay, 12V coil, 120-240 VAC rated	
25	14231	3	Nut, 10-32 hex, G2	
26	35886B	1	Box, control	
--	68175	1	Wire group, control box	
--	31353	1	Assembly, control box w/controller	

OPTIONAL FEATURES

Interior Cabinet Light:

A	11947	1	Light, interior with switch
B	60364	4	Screw, 10-16 x .500 std hex, G2, self-drilling

CONTROL PANEL ASSEMBLY

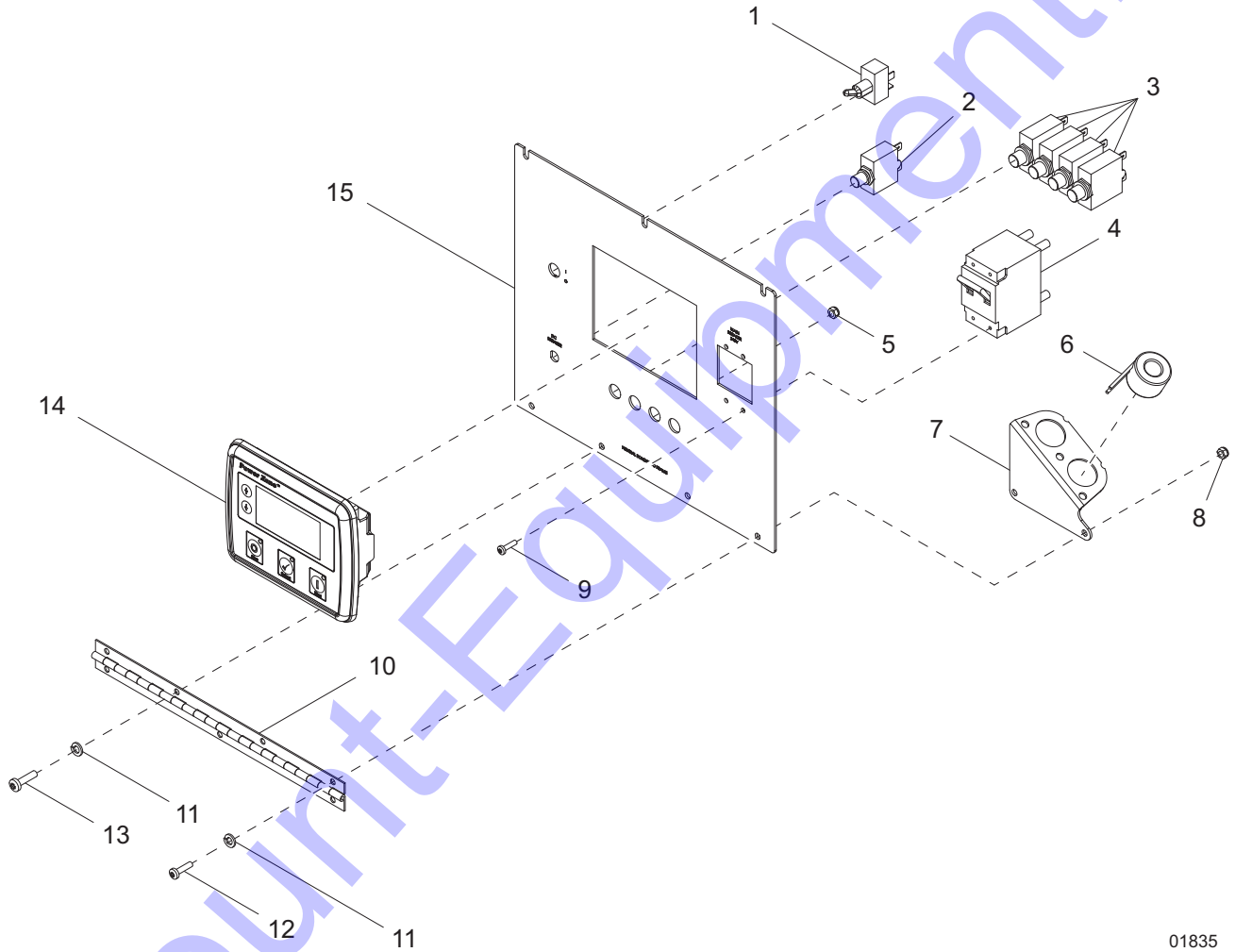

01835

CONTROL PANEL ASSEMBLY

Item	Part No.	Qty	Description	Notes
1	25077	1	Switch, toggle - SPST 20A VAC	
2	65850	1	Breaker, 10A, 240V, 1 pole, push button	
3	15568	4	Breaker, 15A, 120V, 1 pole, push button	
4	65429	1	Breaker, 100A, 250V, 2 pole, stud terminal w/aux	
5	60270	2	Nut, 8-32 nylock	
6	66255	2	Transformer, current - 100:5	
7	37212B	1	Bracket, current transformer	
8	14231	2	Nut, 10-32 hex, G2	
9	60405	4	Screw, 6-32 x .250 pan phil, G2	
10	13677	1	Hinge, continuous - 11 in	
11	60252	4	Washer, #10 split lock	
12	60277	2	Screw, 10-32 x .500 pan phil, G2	
13	60694	2	Screw, 8-32 x .750 pan phil, SS	
14	68798	1	Controller, MLT4200IF4/MTT20	
15	37090	1	Panel, control	
--	31354	1	Assembly, control panel	Items 1-15
--	31356	1	Wire group - control panel	

COOLING SYSTEM ASSEMBLY

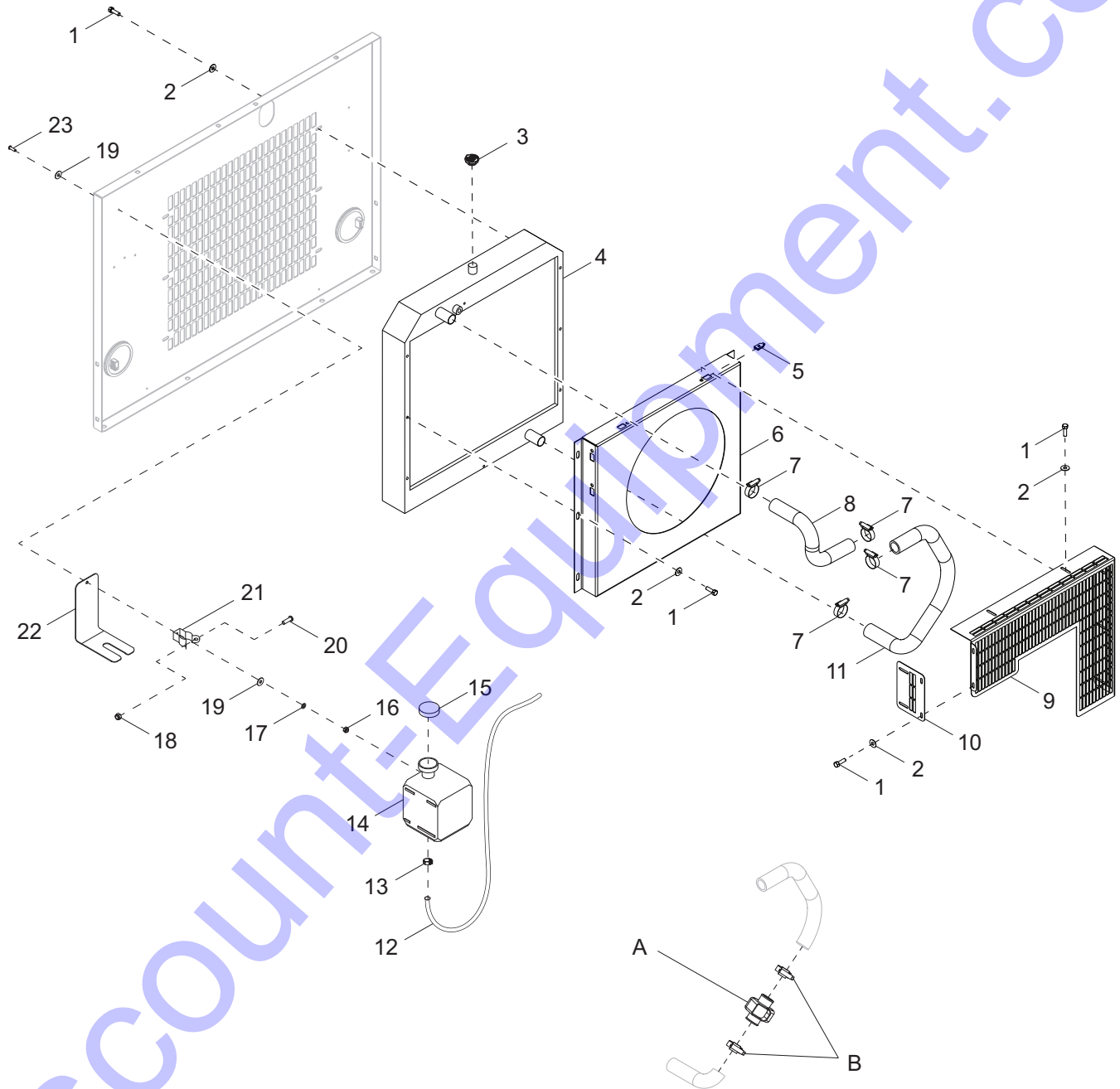

01576

COOLING SYSTEM ASSEMBLY

Item	Part No.	Qty	Description	Notes
1	60690	19	Screw, .375-16 x 1.0 std hex, SS	
2	60698	19	Washer, .375 flat .875/.040, SS	
3	19219	1	Cap, radiator	
4	13660	1	Radiator, 20kW	
5	62086	7	Nut, .312-18 U-clip - short-type	
6	37086B	1	Shroud, fan	
7	15422	4	Clamp, hose - SAE 020 (.75-1.75)	
8	12064	1	Hose, radiator upper	
9	37082B	1	Guard, fan upper	
10	37083B	1	Guard, fan lower	
11	31567	1	Hose, radiator lower	
12	16232	1	Hose, fuel - .312 ID, 50 psi, SAE 30R7 - 12 in	
13	60777	1	Clamp, hose - .312 fuel hose crimp style	
14	20287	1	Jug, overflow	
15	19714	1	Cap, overflow jug	
16	60061	2	Nut, 10-32 nylock	
17	60696	2	Washer, .250 flat .625/.050, SS	
18	60144	1	Nut, .250-20 nylock, G5	
19	60067	4	Washer, #10 flat .435/.060, SS	
20	60414	1	Screw, .250-20 x 1.50 std hex, G5	
21	19726	1	Clamp, overflow jug	
22	22419B	1	Bracket, overflow jug	
23	61180	2	Screw, 10-32 x .750 pan phil, SS	
--	14410	1	Assembly, overflow jug	Items 12-23

OPTIONAL FEATURES

Lower Radiator Hose Heater:

A	65648	1	Heater, engine - low rad hose, 1.25 dia
B	15422	2	Clamp, hose - SAE20 (.75-1.75)

ENGINE AND GENERATOR TO UNIT

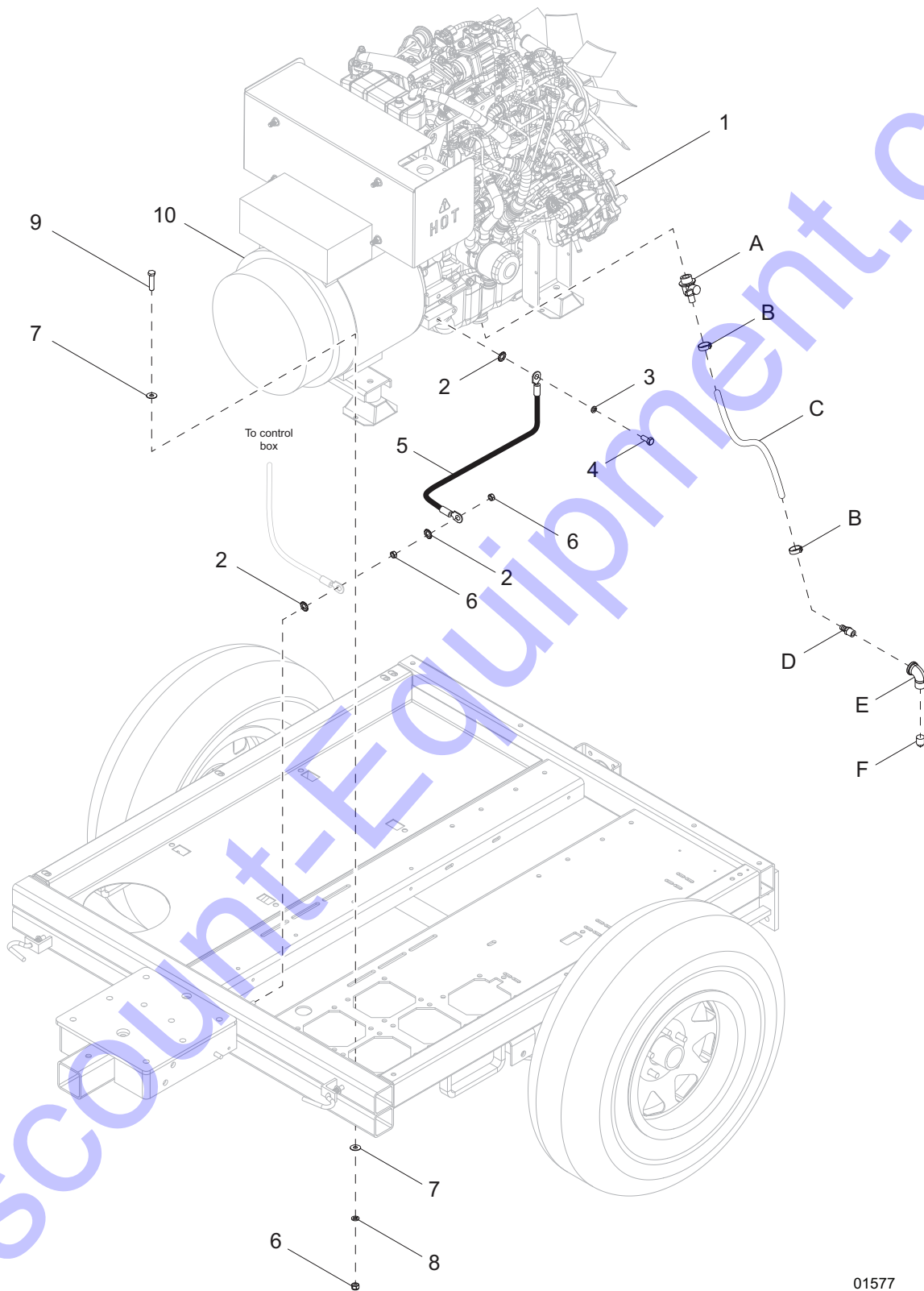

01577

ENGINE AND GENERATOR TO UNIT

Item	Part No.	Qty	Description	Notes
1	Page 42	1	Assembly, engine	
2	60747	3	Washer, .375 internal star	
3	60026	1	Washer, M10 split lock	
4	60495	1	Screw, M10-1.25 x 16 std hex, G8.8	
5	16155	1	Assembly, wire - engine/chassis ground	
6	60140	10	Nut, .375-16 hex, G5	
7	60698	16	Washer, .375 flat .875/.040, SS	
8	60206	8	Washer, .375 split lock	
9	60690	8	Screw, .375-16 x 1.0 std hex, SS	
10	Page 46	1	Assembly, generator	

OPTIONAL FEATURES

Oil Drain Valve:

A	31408	1	Valve, drain with nipple
B	60777	2	Clamp, hose - .312, crimp style
C	50051	6 ft	Hose, fuel - .375 ID, 50 psi
D	62076	1	Fitting, strt - .750MNPT x .625 barb
E	25110	1	Fitting, 90° - .750MNPT x .750FNPT
F	60498	1	Fitting, square plug - .750NPT

ENGINE ASSEMBLY - LEFT SIDE

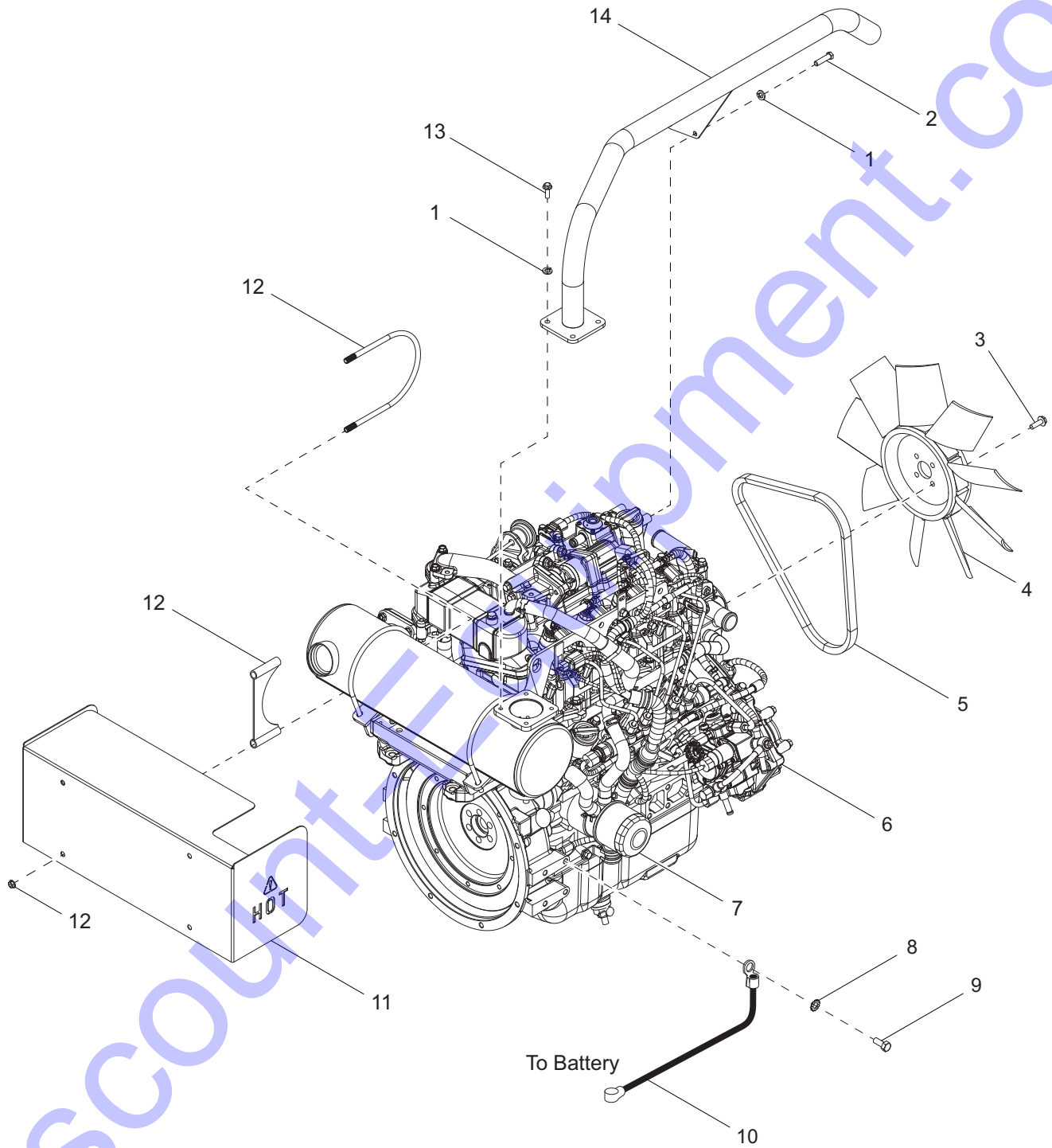

01821

Note: ENGINE ASSEMBLY - LEFT SIDE

Item	Part No.	Qty	Description	Notes
1	60271	6	Washer, .312 split lock	
2	60410	2	Screw, M8-1.25 x 16 std hex, G8.8	
3	60024	4	Screw, M6-1.0 x 25 sflg hex	
4	19258	1	Fan, 15.75 in	
5	51099	1	Belt, fan	
6	37216	1	Engine, Isuzu - 4LE2T T4 40HP	
7	15183	1	Filter, oil	
8	60747	1	Washer, .375 internal star	
9	60495	1	Screw, M10-1.25 x 16 std hex, G8.8	
10	15073	1	Cable, battery - 24 in., 4GA black, .438 lug	
11	31406BH	1	Weldment, doc heat shield	
12	35925	2	Clamp, U-bolt	
13	60009	4	Screw, M8-1.25 x 25 sflg hex, G8.8	
14	35976	1	Weldment, exhaust pipe	
--	33766	1	Harness, engine - Isuzu	
--	34588	12.5 ft	Insulation, exhaust tape	Attaches to item 14

Note: Engine and generator parts used in all Generac Mobile Products equipment carry the Original Equipment Manufacturer (OEM) warranty unless otherwise stated. OEM warranty parts must be purchased through an OEM dealer.

ENGINE ASSEMBLY - RIGHT SIDE

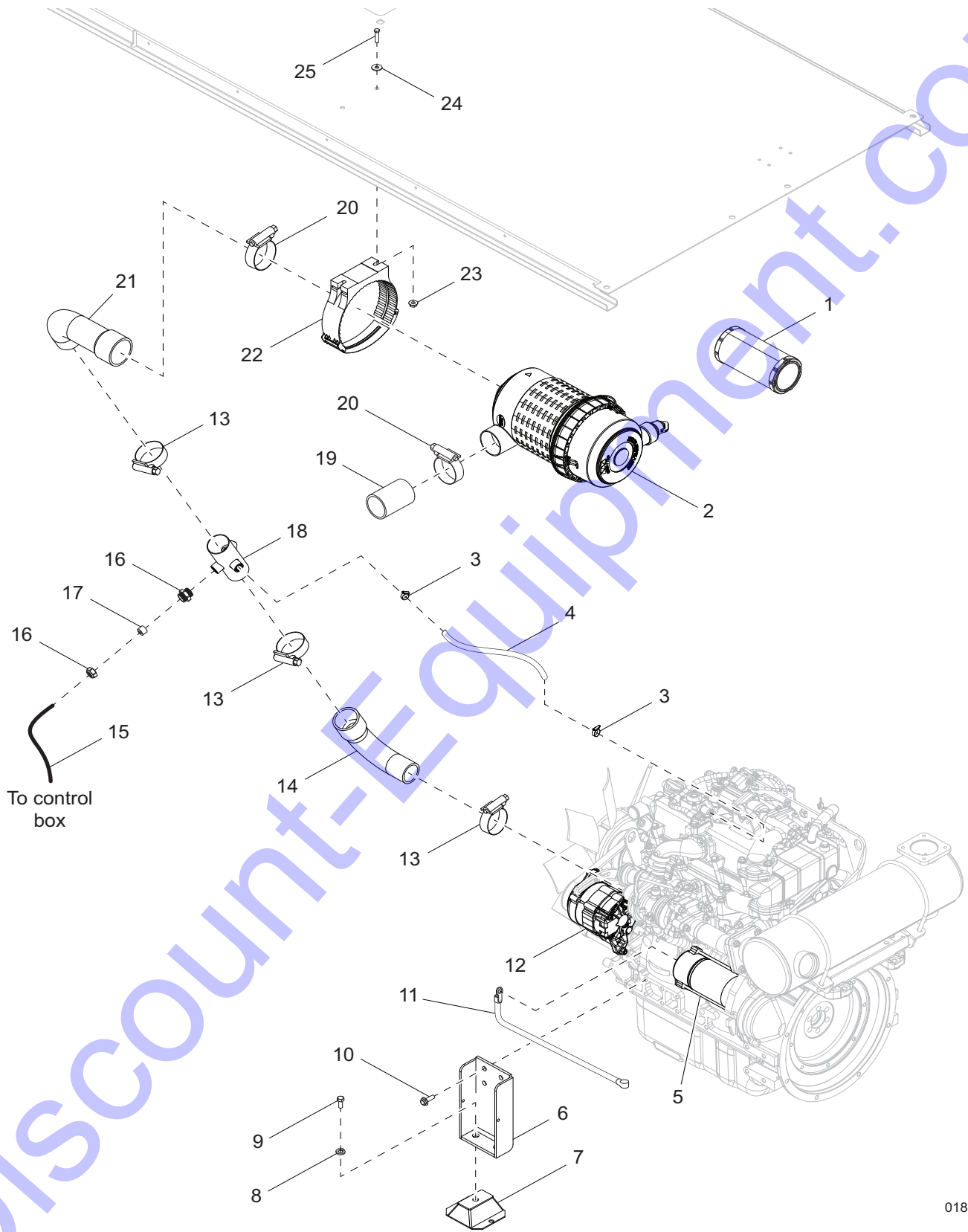

01810

ENGINE ASSEMBLY - RIGHT SIDE

Item	Part No.	Qty	Description	Notes
1	35962	1	Element, air filter	
2	35959	1	Filter, air	
3	60365	2	Clamp, hose - SAE 010 (.56-1.06)	
4	50709	1.75 ft	Hose, fuel - .625 ID, 300 psi	
5	36662	1	Starter	
6	31564B	2	Weldment, engine mount	
7	11524	2	Isolator, rubber - 4.38 x 4.0 x 1.50	
8	60702	2	Washer, .500 split lock, SS	
9	60275	2	Screw, .500-13 x 1.0 std hex, G5	
10	60018	6	Screw, M10-1.50 x 20 sflg hex	
11	15074	1	Cable, battery - 38 in., 4GA red, .438 lug	
12	36661	1	Alternator	
13	60316	3	Clamp, hose - SAE 032 (1.56-2.50)	
14	35960	1	Hose, air filter	
15	68372	1	Harness, PCV hose heater, 26" insertion, 72" cord	
16	38467	1	Cord grip, 1/2 liquid tight	
17	38465	1	Spacer, Romex rubber	
18	38513BH	1	Weldment, air inlet fitting tube, .50-.50-.38 coup	
19	38421	1	Hose, air filter connection - 20 kW	
20	19336	2	Clamp, hose - SAE 044 (2.31-3.25)	
21	31571	1	Hose, air	
22	37480	1	Bracket, air filter	
23	60095	2	Nut, .312-18 sflg	
24	60340	2	Washer, .312 flat .875/.040	
25	60687	2	Screw, .312-18 x .75 std hex, SS	

Note: Engine and generator parts used in all Generac Mobile Products equipment carry the Original Equipment Manufacturer (OEM) warranty unless otherwise stated. OEM warranty parts must be purchased through an OEM dealer.

GENERATOR ASSEMBLY

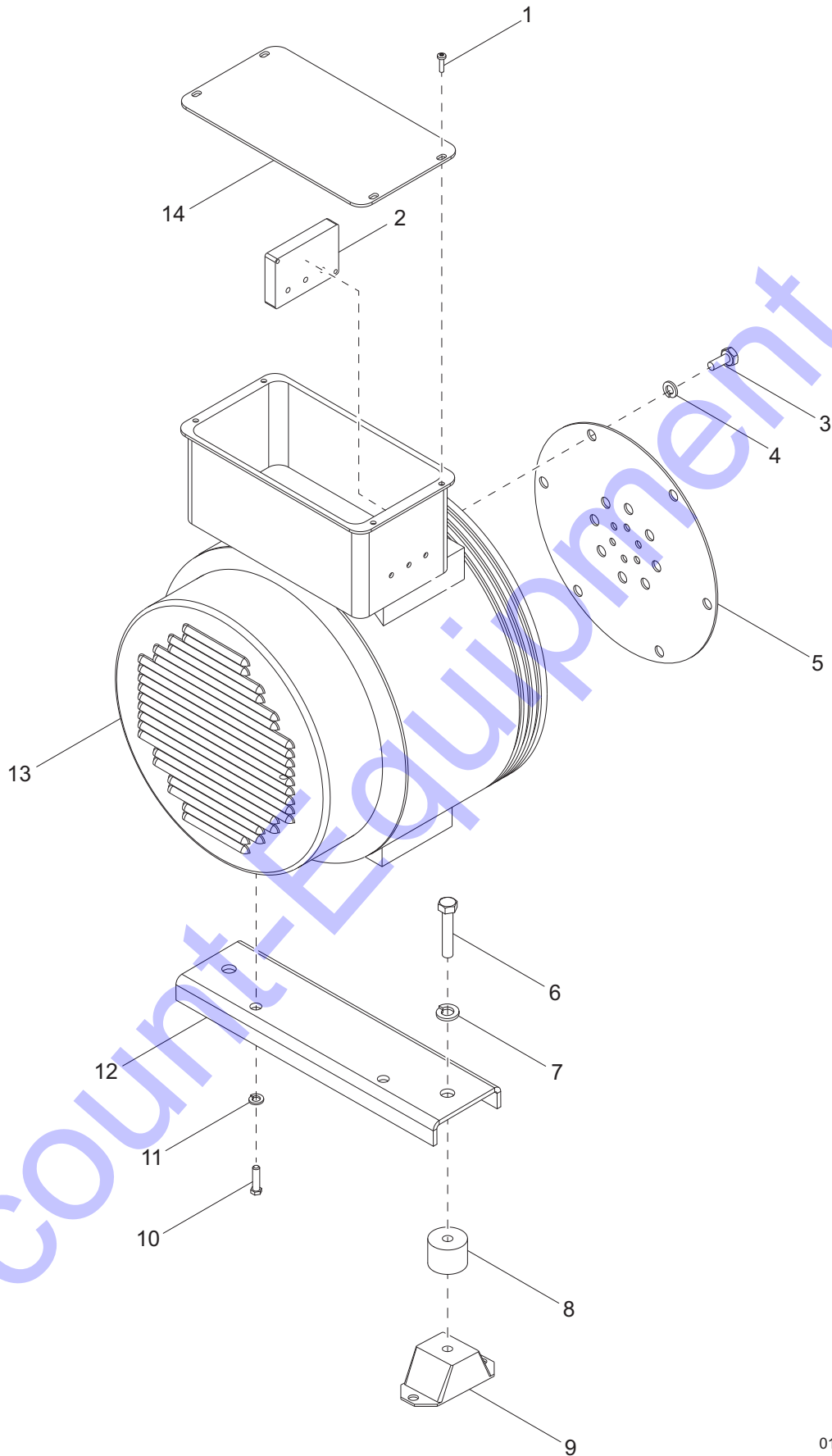

01580

GENERATOR ASSEMBLY

Item	Part No.	Qty	Description	Notes
1	60398	4	Screw, 10-32 x 5.0 pan phil, SS	
2	18556	1	Regulator, voltage	
3	60495	6	Screw, M10-1.25 x 16 std hex, G8.8	
4	60026	6	Washer, M10 split lock	
5	11000	1	Plate, drive	
6	60484	2	Screw, .500-13 x 2.0 std hex, G5	
7	60702	2	Washer, .500 split lock, SS	
8	19339Z	2	Spacer, 2.0 x 1.5	
9	11524	2	Isolator, rubber - 4.38 x 4.0 x 1.50	
10	60690	2	Screw, .375-16 x 1.0 std hex, SS	
11	60206	2	Washer, .375 split lock	
12	11597B	1	Bracket, generator mounting	
13	11481	1	Generator, Marathon - 334CSA3028, 20 kW	
14	12736	1	Cover, generator	

Note: Engine and generator parts used in all Generac Mobile Products equipment carry the Original Equipment Manufacturer (OEM) warranty unless otherwise stated. OEM warranty parts must be purchased through an OEM dealer.

FUEL TANK AND TRANSFORMERS TO UNIT

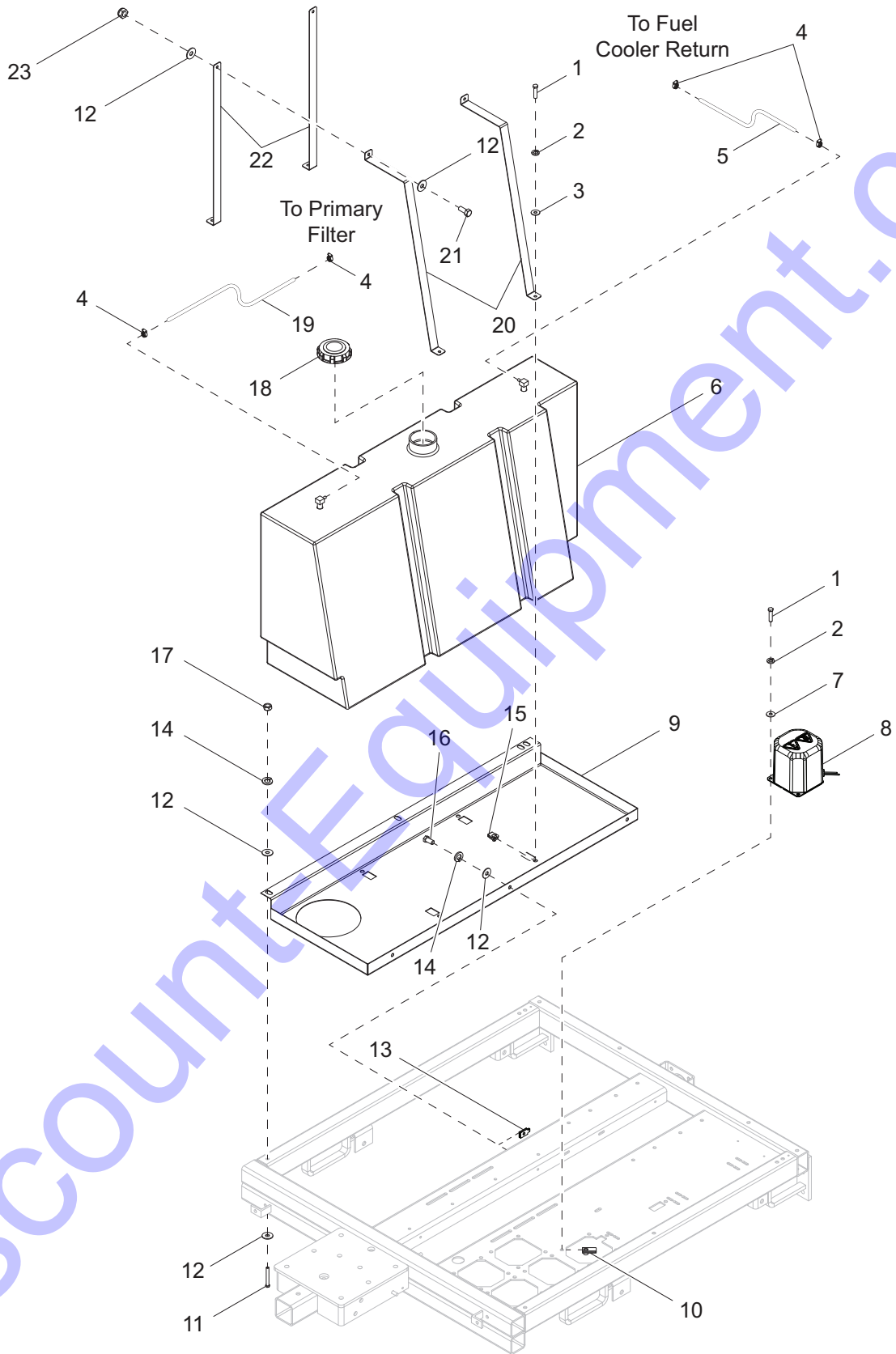

01581

FUEL TANK AND TRANSFORMERS TO UNIT

Item	Part No.	Qty	Description	Notes
1	60028	16	Screw, .312-18 x 1.0 std hex, G5	
2	60271	16	Washer, .312 split lock	
3	60119	16	Washer, .312 flat .875/.070	
4	60365	4	Clamp, hose - SAE 010 (.56-1.06)	
5	50051	5 ft	Hose, fuel - .375 ID, 50 psi, SAE 30R7	
6	31347	1	Tank, fuel - 50 gallon	
7	60243	12	Washer, .250 flat .735/.060	
8	10656	4	Assembly, transformer - can & base - 60Hz-MH-5.5 in	
9	37067B	1	Pan, fuel tank	
10	62086	12	Nut, .312-18 U-clip - short type	
11	60689	3	Screw, .375-16 x 4.0 std hex, SS	
12	60698	11	Washer, .375 flat .875/.040, SS	
13	60727	3	Nut, .375-16 U-clip, short type	
14	60703	6	Washer, .375 split lock, SS	
15	60505	4	Nut, .312-18 U-clip - long type	
16	60690	3	Screw, .375-16 x 1.0 std hex, SS	
17	60140	3	Nut, .375-16 hex, G5	
18	16326	1	Cap, fuel tank, 3.50 dia - green w/tether	
19	50051	.66 ft	Hose, fuel - .375 ID, 50 psi, SAE 30R7	
20	37087B	2	Strap, fuel tank - large	
21	60334	1	Screw, .375-16 x 1.0, std hex, G5	
22	37088B	2	Strap, fuel tank - small	
23	60358	1	Nut, .375-16 nylock, G5	

TRAILER ASSEMBLY

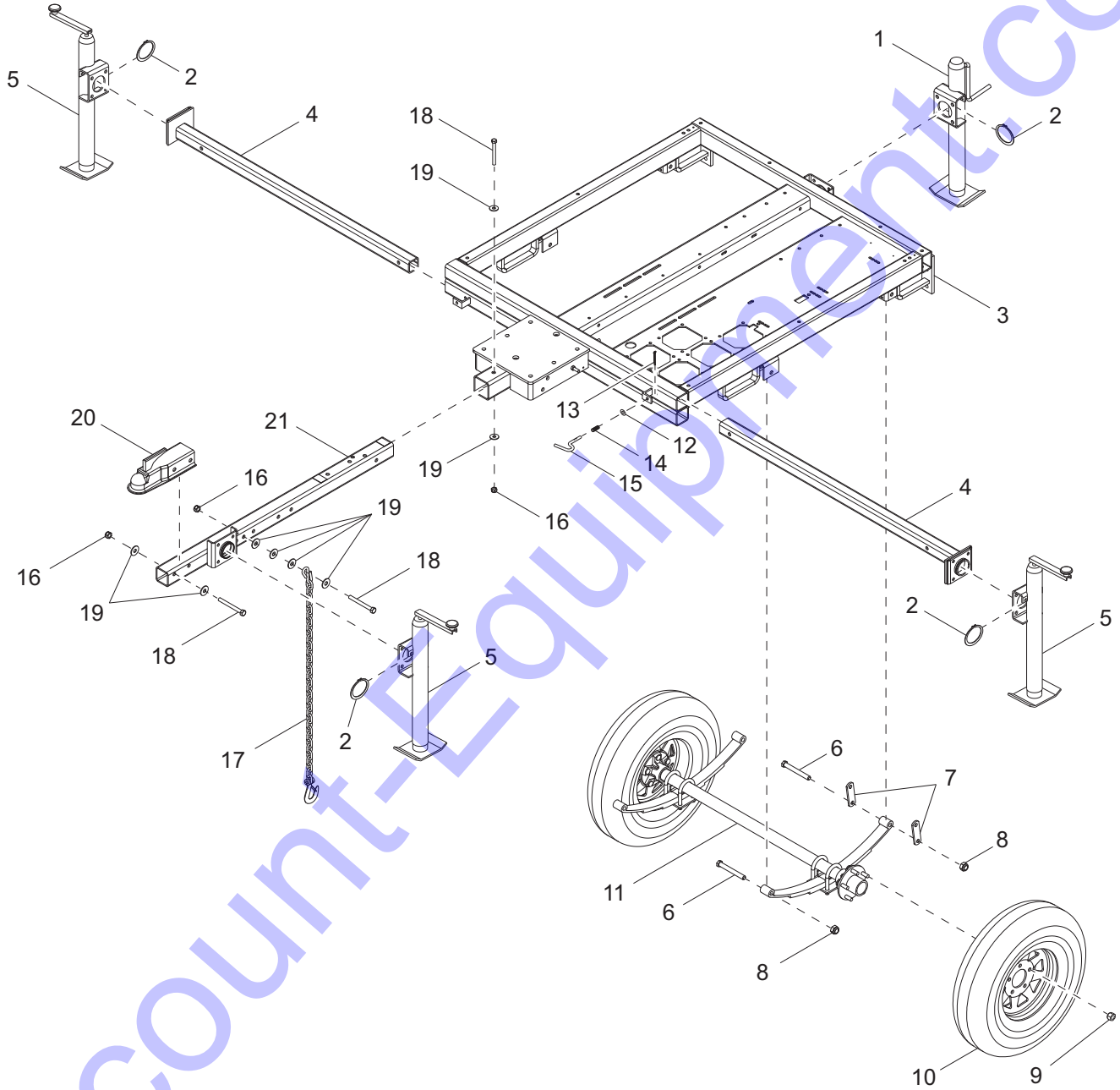

01582

TRAILER ASSEMBLY

Item	Part No.	Qty	Description	Notes
1	11681	1	Jack, side wind - 2000 lb	
2	14326	4	Ring, retaining	
3	13335B	1	Weldment, chassis	
4	12408Z	2	Weldment, outrigger	
5	11682	3	Jack, top wind - 2000 lb	
6	60503	6	Screw, shackle - .562-18 x 3.0 std hex, G5	
7	19637	4	Plate, shackle bracket	
8	60504	6	Nut, .562-18 lock hex, G5	
9	60096	10	Nut, .500-20 lug, G5	
10	15540	2	Wheel, ST205/75R15, 1598 lb	
11	<i>Page 54</i>	1	Assembly, axle	
12	35275	2	Washer, .375 flat .416 x .820 x .057	
13	35274	2	Cotter pin, 5/64 x 1.0	
14	35273	2	Spring, compression - .562 x 1.50	
15	35272	2	Pin, plunger, .375	
16	62221	11	Nut, .500-13 nylock, G5	
17	23367	2	Chain, safety	
18	50215	9	Screw, .500-13 x 4.0 std hex, G5	
19	60416	28	Washer, .500 flat 1.375/.090	
20	16830	1	Coupler, 2.00 ball/2.50 channel	
21	12420B	1	Weldment, removable tongue	

TRAILER OPTIONS

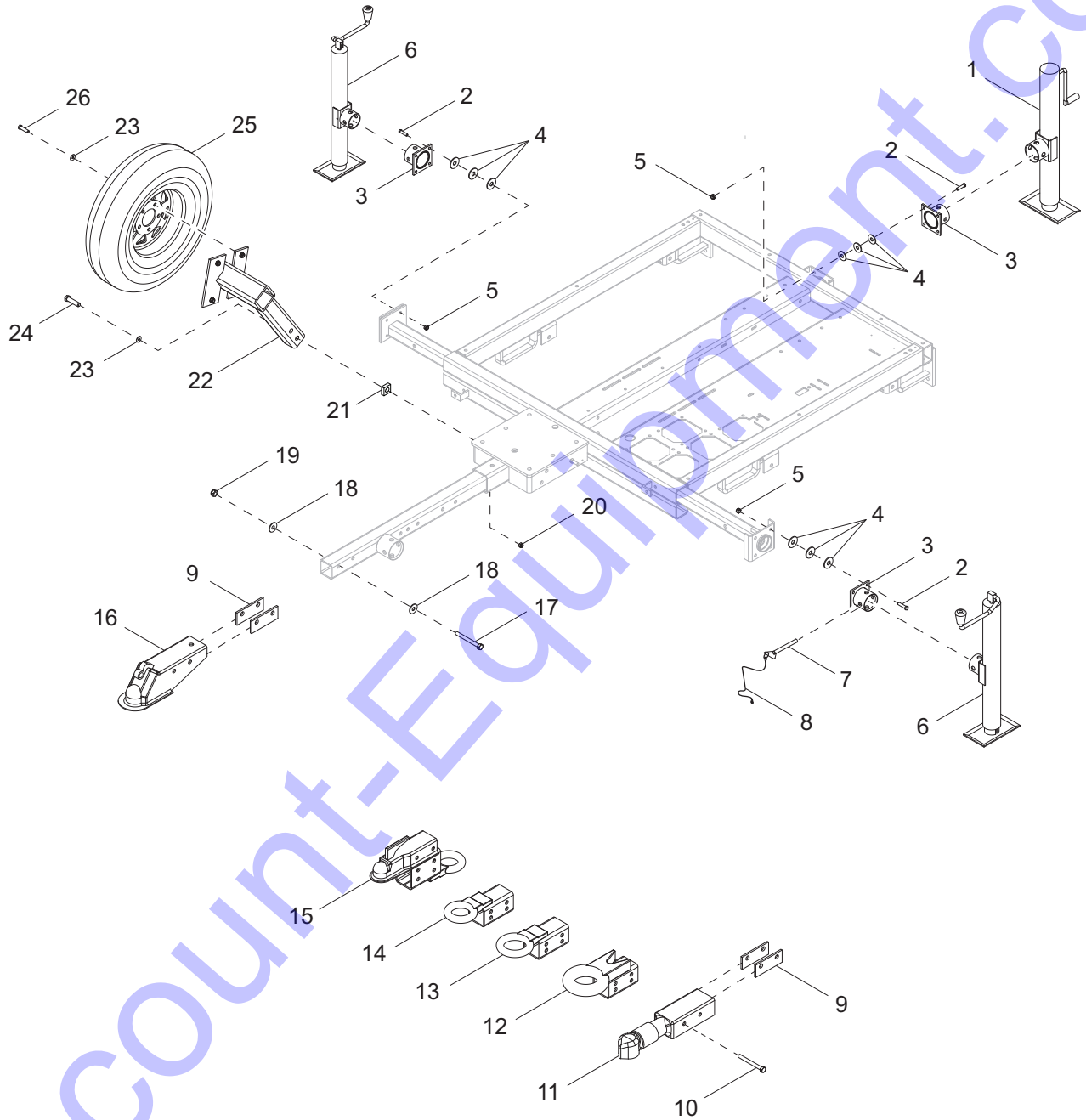

01175

TRAILER OPTIONS

Item	Part No.	Qty	Description	Notes
<i>Tube Mount Jacks:</i>				
1	11978	1	Jack, side wind - 2000 lb, tube mount	
2	61036	12	Screw, .375-16 x 1.250 std hex, SS	
3	11965Z	3	Weldment, jack adapter	
4	60698	36	Washer, .375 flat .875/.040, SS	
5	60358	12	Nut, .375-16 nylock, G5	
6	23254	2	Jack, top wind - 2000 lb, tube mount	
7	23256	4	Pin, jack - 2000 lb, tube mount	
8	12647	4	Cable, tether - jack pin and ground rod cover	
<i>Hitches:</i>				
9	12155B	2	Spacer, coupler	
10	60376	2	Screw, .500-13 x 4.50 std hex, G5	
11	13003B	1	Coupler, 2.0 ball/3.0 channel	
12	11672B	1	Weldment, hitch - 3.0 x 1.625 ring/2.50 tube	
13	16835B	1	Weldment, lunette ring - 3.0 x 1.0 ring/2.50 tongue	
14	16999B	1	Weldment, lunette ring - 2.5 x 1.0 ring/2.50 tongue	
15	16741ZC	1	Weldment, combo hitch - 2.50 tongue	
16	12229	1	Coupler, 2.31 ball/3.0 channel	
17	50215	2	Screw, .500-13 x 4.0 std hex, G5	Attaches items 11-15
18	60309	4	Washer, .500 flat 1.060/.090	Attaches items 11-15
19	62221	2	Nut, .500-13 nylock, G5	Attaches items 10-15
<i>Spare Tire Carrier:</i>				
20	62221	2	Nut, .500-13 nylock, G5	
21	12081	2	Spacer, racking	
22	12235B	1	Weldment, spare tire holder	
23	60700	4	Washer, .500 flat 1.250/.060, SS	
24	60388	2	Screw, .500-13 x 1.50 std hex, G5	
25	15540	1	Wheel, ST205/75R15, 1598 lb	
26	60275	2	Screw, .500-13 x 1.0 std hex, G5	
<i>Trailer Plug Adapters:</i>				
--	65463	1	Adapter, trailer wiring - flat 4 pin to round 6 pin	
--	65464	1	Adapter, trailer wiring - flat 4 pin to round 7 pin	
--	65465	1	Adapter, trailer wiring - flat 4 pin to round 7 blade	
<i>Containment:</i>				
--	10496B	1	Weldment, It chassis - 60 gal containment	

AXLE ASSEMBLY

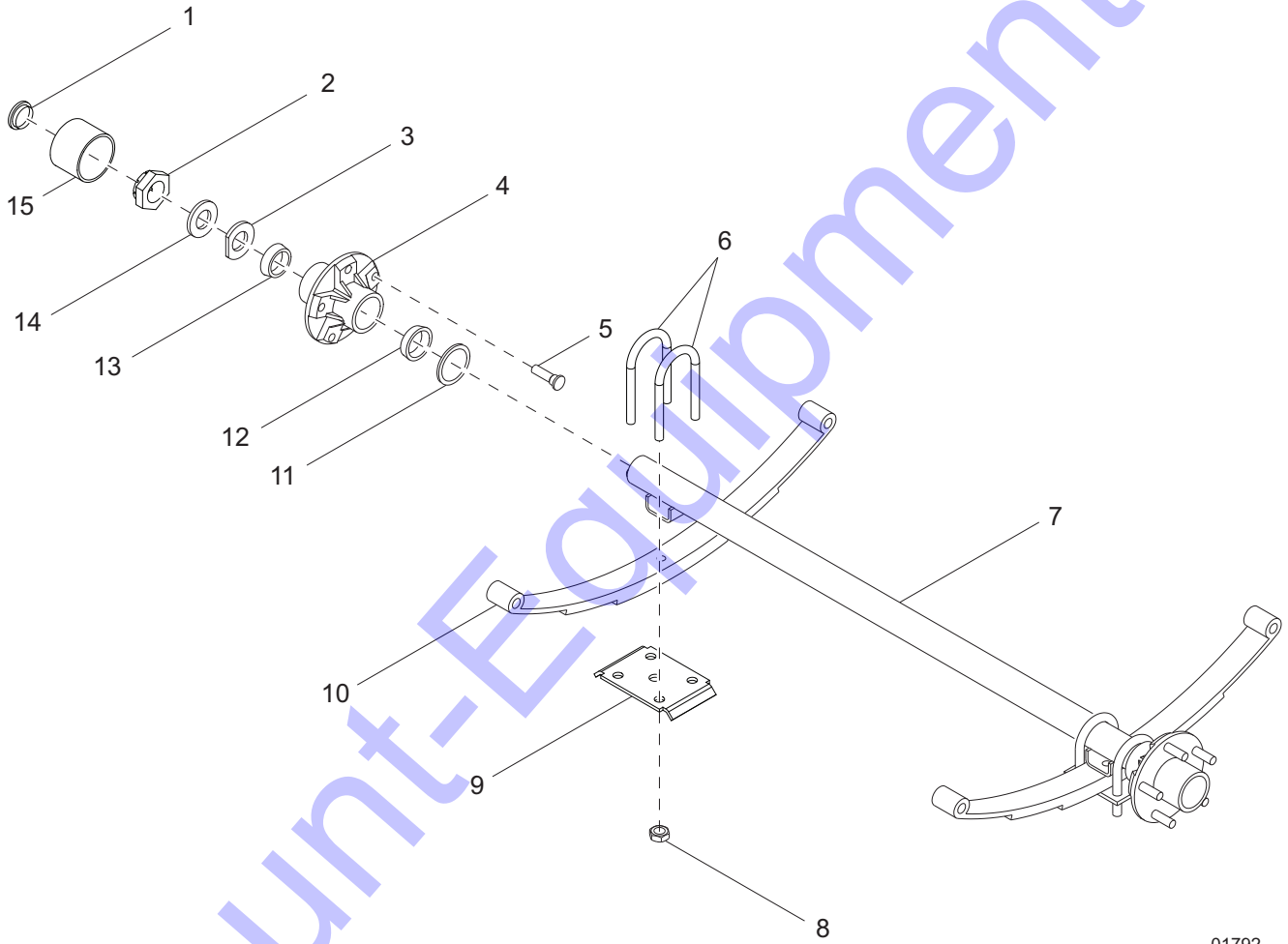

01792

AXLE ASSEMBLY

Item	Part No.	Qty	Description	Notes
1	70054	2	Rubber plug	
2	12308	2	Spindle nut	
3	12309	2	D-washer	
4	11276	2	Hub w/races	
5	60674	10	Stud, wheel	
6	11277	4	U-bolt	
7	13131	1	Axle, 3000 lb	
8	11279	8	Axle nut	
9	11278	2	Tie plate	
10	11280	2	Axle leaf spring	
11	70056	2	Bearing seal	
12	11511	2	Roller bearing	
13	70055	2	Bearing L44643	
14	12310	2	Tang washer	
15	70053	2	Dust cap	

RECOMMENDED SPARE PARTS LIST

ENGINE

Alternator	36661
Belt, fan	51099
Cap, radiator	19219
Element, air filter	35962
Element, fuel filter - final	36904
Element, fuel filter - primary	36905
Element, oil filter	15183
Fan, engine	19258
Hose, radiator - lower	31567
Hose, radiator - upper	12064
Starter	36662

ELECTRICAL

Assembly, light fixture - hard wired	13311
Assembly, light fixture - quick disconnect	13601
Breaker, main	65429
Breaker, lights	15568
Breaker, 30A	66097
Breaker, 50A	65492
Bulb	11391
Capacitor, lights	65959
Coil cord	11954
Controller	68798
Receptacle, GFI	14130
Receptacle, 30A twist	14137
Receptacle, 240V/50A twist-lock	18089
Transformer (ballast)	10930
Voltage Regulator	18556

MAST

Cable, 11 ft	14151
Cable, 16 ft	14798
Cable, 27 ft	15006
Winch, Handle	15623
Winch, Manual	16600

TRAILER

Jack, side wind (rear)	11681
Jack, top wind (outrigger)	11682
Ring, retaining	14326

MAINTENANCE KITS

250 hour service kit	SK324
2000 hour service kit	SK325

Discount Equipment

Discount-Equipment.com is your online resource for commercial and industrial quality parts and equipment sales.

Locations:

Florida (West Palm Beach): [561-964-4949](tel:561-964-4949)

Outside Florida TOLL FREE: [877-690-3101](tel:877-690-3101)

Need parts? Check out our website at www.discount-equipment.com

Can't find what you need?

Click on this link: <http://www.discount-equipment.com/category/5443-parts/> and fill out the request form.

Please have the machine model and serial number available in order to help us get you the correct parts. One of our experienced staff members will get back to you with a quote for the right part that your machine needs.

We sell worldwide for the brands: Genie, Terex, JLG, MultiQuip, Mayco, Toro/Stone, Diamond Products, Magnum, Airman, Mustang, Power Blanket, Nifty Lift, Atlas Copco, Chicago Pneumatic, Allmand Brothers, Essick, Miller Spreader, Skyjack, Lull, Skytrak, Tsurumi, Husquvarna/Target, Whiteman-Concrete/Mortar, Stow-Concrete/Mortar, Baldor, Wacker, Sakai, Snorkel, Upright, Mi-T-M, Sullair, Neal, Basic, Dynapac, MBW, Weber, Bartell, Bennar Newman, Haulotte, Ditch Runner, Blaw-Knox, Himoinsa, Best, Buddy, Crown, Edco, Wyco, Bomag, Laymor, Terremite, Barreto, EZ Trench, Takeuchi, Basic, Bil-Jax, Curtis, Gehl, Heli, Honda, ICS/PowerGrit, Puckett, Waldon, ASV, IHI, Partner, Imer, Clipper, MMD, Koshin, Rice, Gorman Rupp, CH&E, Cat Pumps, Comet, General Pump, Giant, AMida, Coleman, NAC, Gradall, Square Shooter, Kent, Stanley, Tamco, Toku, Hatz, Kohler, Robin, Wisconsin, Northrock, Oztec, Toker TK, Rol-Air, Small Line, Wanco, Yanmar

New Equipment - Used Equipment - Rental Equipment - Parts and Accessories

Discount Equipment

www.discount-equipment.com

561-964-4949

Sales: info@Discount-Equipment.com

Parts: wbparts@Discount-Equipment.com



www.discount-equipment.com

Discount-Equipment.com