

GENERAC®

MAGNUM

Owner's Manual
Light Tower

PLT240 LINK Tower

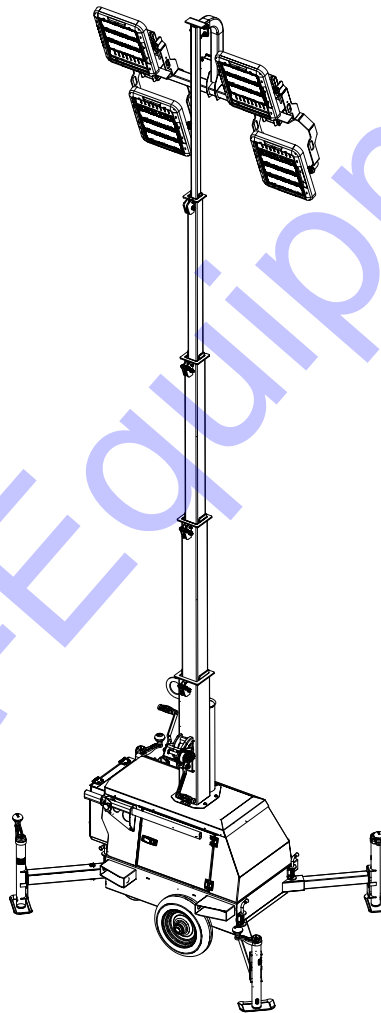

**Discount
Equipment**

www.discount-equipment.com

SAVE THIS MANUAL FOR FUTURE REFERENCE

Use this page to record important information about your Light Tower

Unit Model Number	
Unit Serial Number	

Record the information found on your unit data label on this page. See unit serial number location (***Unit Serial Number Locations***). The data plate is affixed to the mast inside the cabinet.

When contacting an Generac Mobile Products Authorized Dealer about parts and service, always supply the complete model number and serial number of the unit.

Operation and Maintenance: Proper maintenance and care of the Light Tower ensures a minimum number of problems and keeps operating expenses at a minimum. It is the operator's responsibility to perform all safety checks, to verify that all maintenance for safe operation is performed promptly, and to have the equipment checked periodically by a Generac Mobile Products Authorized Dealer. Normal maintenance, service and replacement of parts are the responsibility of the owner/operator and, as such, are not considered defects in materials or workmanship within the terms of the warranty. Individual operating habits and usage may contribute to the need for additional maintenance or service.

 **WARNING**

CANCER AND REPRODUCTIVE HARM

www.P65Warnings.ca.gov

(000393a)

Table of Contents

Section 1: Introduction and Safety

Introduction	1
Read This Manual Thoroughly	1
How to Obtain Service	1
Safety Rules	1
General Hazards	2
Fire Hazards	2
Electrical Hazards	2
Operating Safety	2
Positioning the Unit	2
Starting the Unit	3
Raising and Lowering the Mast	3
Service Safety	3
Safety and Operating Decals	3

Section 2: General Information

Specifications	5
Unit Serial Number Locations	6
Unit Dimensions	7
Component Locations	8
Control Panel	9
Control Panel Components and Functions	9
Internal Storage	10
Lifting and Transporting	10
Lifting the Unit	10
Transporting the Unit	10
Tying the Unit Down	11

Section 3: Operation

Operation Configuration	13
LED Lights Only	13
LED Lights and Auxiliary Power	13
Light Tower Setup	13
Raising the Mast	14
Prestart Checklist	15
Turn Unit ON	16
Turn Unit OFF	16
Lowering the Mast	16
Long-Term Storage	16

Section 4: Maintenance

Daily Walk-Around Inspection	17
General Maintenance	17
Preparing for Service	17
Cleaning the Unit	17
Inspecting the Unit	17
Basic Maintenance Schedule	17
Winch Use, Operation and Maintenance	18
Prior to Use	18
Operation	18
Maintenance	18
Winch Mechanical Brake	18
Jack Maintenance	18
Wheel Maintenance	18

Section 5: Troubleshooting

Troubleshooting the Lights	19
---	----

Section 6: Wiring Diagrams

AC Wiring	21
------------------------	----

Section 1: Introduction and Safety

Introduction

Thank you for purchasing a Generac Mobile Products LLC product. This unit has been designed to provide high performance, efficient operation, and years of use when maintained properly.

The information in this manual is accurate based on products produced at the time of publication. The manufacturer reserves the right to make technical updates, corrections, and product revisions at any time without notice.

Read This Manual Thoroughly



⚠ WARNING

Consult Manual. Read and understand manual completely before using product. Failure to completely understand manual and product could result in death or serious injury. (000100a)

If any section of the manual is not understood, contact your nearest Generac Mobile Products Authorized Dealer.

The owner is responsible for proper maintenance and safe use of the equipment. Comply with regulations the Occupational Safety and Health Administration (OSHA) has established, or with equivalent standards. Also, verify that the unit is applied, used, and maintained in accordance with the manufacturer's instructions and recommendations. Do nothing that might alter safe application/usage and render the unit in noncompliance with the aforementioned codes, standards, laws, and regulations.

Save these instructions for future reference. This manual contains important instructions for the unit that should be followed during setup, operation and maintenance of the unit and battery. ALWAYS supply this manual to any individual that will use this machine.

How to Obtain Service

When the unit requires servicing or repairs, contact a Generac Mobile Products Authorized Dealer for assistance. Service technicians are factory-trained and are capable of handling all service needs.

Record the model number and serial numbers in the spaces provided on the inside front cover of this manual.

Safety Rules

The manufacturer cannot anticipate every possible circumstance that might involve a hazard. The warnings in this manual, and on tags and decals affixed to the unit are, therefore, not all inclusive. If using a procedure, work method or operating technique that the manufacturer does not specifically recommend, verify that it is safe for others. Also make sure the procedure, work method or operating technique utilized does not render the equipment unsafe.

Throughout this publication, and on tags and decals affixed to the unit, DANGER, WARNING, CAUTION and NOTE blocks are used to alert personnel to special instructions about a particular operation that may be hazardous if performed incorrectly or carelessly. Observe them carefully. Their definitions are as follows:

⚠ DANGER

Indicates a hazardous situation which, if not avoided, will result in death or serious injury.

(000001)

⚠ WARNING

Indicates a hazardous situation which, if not avoided, could result in death or serious injury.

(000002)

⚠ CAUTION

Indicates a hazardous situation which, if not avoided, could result in minor or moderate injury.

(000003)

NOTE: Notes contain additional information important to a procedure and will be found within the regular text of this manual.

These safety alerts cannot eliminate the hazards that they indicate. Common sense and strict compliance with the special instructions while performing the action or service are essential to preventing accidents.

General Hazards



⚠️ WARNING

Moving Parts. Keep clothing, hair, and appendages away from moving parts. Failure to do so could result in death or serious injury.

(000111)



⚠️ WARNING

Hot Surfaces. When operating machine, do not touch hot surfaces. Keep machine away from combustibles during use. Hot surfaces could result in severe burns or fire.

(000108)

⚠️ WARNING

Risk of injury. Do not operate or service this machine if not fully alert. Fatigue can impair the ability to service this equipment and could result in death or serious injury.

(000215)

⚠️ WARNING

Personal injury. Do not operate unit during transport. Doing so could result in death, serious injury, or property damage.

(000231a)

⚠️ WARNING

Crushing hazard. Verify unit is properly secured and on level ground. An unsecured unit can suddenly roll or move, causing death or serious injury.

(000234a)

⚠️ CAUTION

Equipment Damage. Failure to perform a daily inspection could result in damage to the unit.

(000306)

Fire Hazards



⚠️ WARNING

Risk of Fire. Hot surfaces could ignite combustibles, resulting in fire. Fire could result in death or serious injury.

(000110)

Electrical Hazards



⚠️ DANGER

Electrocution. In the event of electrical accident, immediately shut power OFF and disconnect unit from source. Use non-conductive implements to free victim from live conductor. Apply first aid and get medical help. Failure to do so will result in death or serious injury.

(000354)



⚠️ DANGER

Electrocution. Water contact with a power source, if not avoided, will result in death or serious injury.

(000104)



⚠️ DANGER

Electrocution. Verify electrical system is properly grounded before applying power. Failure to do so will result in death or serious injury.

(000152)



⚠️ DANGER

Electrocution. Do not wear jewelry while working on this equipment. Doing so will result in death or serious injury.

(000188)



⚠️ DANGER

Electrocution. DO NOT use the unit if electrical cord is cut or worn through. Doing so will result in death or serious injury.

(000263a)

Operating Safety

Positioning the Unit



⚠️ DANGER

High Voltage. Verify area above unit is clear of overhead wires and obstructions. Contact with high-voltage power lines will result in death or serious injury.

(000260a)

- The area immediately surrounding the unit should be dry, clean, and free of debris.
- Position and operate the unit on a firm, level surface.
- If the unit requires external grounding (using the grounding stud on the control panel), follow any local, state, and National Electrical Code (NEC) guidelines when connecting.

Starting the Unit



DANGER

Electrocution. **DO NOT** use the unit if electrical cord is cut or worn through. Doing so will result in death or serious injury.

(000263a)

- **DO NOT** start a unit in need of repair.

Raising and Lowering the Mast



WARNING

Electrocution. Do not set up or operate this unit if severe weather is expected. Lightning strikes can kill or cause severe injury even if you are not touching the unit. (000296)



WARNING

Personal Injury. Do not set-up or operate unit in high winds. Doing so could result in death, serious injury, property, or unit damage. (000345)

IMPORTANT NOTE: Unit wind rating is 45 mph.

WARNING

Personal Injury. Stop immediately if the mast hangs up or the winch cable develops slack. Excess slack could cause the mast to collapse, resulting in personal injury or equipment damage. (000265)



WARNING

Personal injury. Use caution when winding winch cable. Failure to do so could result in serious injury. (000391)

- **ALWAYS** extend the outriggers and level the unit before raising the mast. **DO NOT** retract the outriggers while the mast is up.
- Keep area around the unit clear of people while raising and lowering the mast.
- **ALWAYS** lower the mast when not in use.

Service Safety

This unit uses high voltage circuits capable of causing serious injury or death. Only a qualified and licensed electrician should troubleshoot or repair problems occurring in this equipment.

- Before servicing the unit, verify the main breaker switch and circuit breakers are in the OFF (O) position, and the shore power cord is disconnected.

DO NOT perform routine maintenance unless all electrical components are shut down.

- **ALWAYS** use extreme care when servicing this unit in damp conditions. Do not service the unit if your skin or clothing is wet. Do not allow water to collect around the base of the unit.
- **DO NOT** wash the unit with high pressure hoses, power washers, or steam cleaners. Water may collect in the unit, causing damage to electrical parts.
- Replace all missing and hard to read decals. Decals provide important operating instructions and warn of dangers and hazards.
- Wear heavy leather gloves when handling winch cables. Never let cables slip through bare hands.
- Only use mild soap and water to clean the lens covers. Other chemicals may damage the lens covers.

Safety and Operating Decals

See [Table 1-1](#) and [Figure 1-1](#). This unit features numerous safety and operating decals. These decals provide important operating instructions and warn of dangers and hazards. The following diagrams illustrate decal locations and descriptions.

Replace any missing or hard-to-read decals and use care when washing or cleaning the unit. Decal part numbers can be found in the parts manual at

Table 1-1. Decal Descriptions

ID	Description
1	Warning—Entanglement Hazard
2	Lifting Point
3	Notice—Correctly Wind Winch
4	Warning—Crushing Hazard
5	Danger—Electrical Storms, High Wind and Overhead Wires
6	Notice—Interconnect (located on flat beneath right side receptacles)
7	Quick Start Guide
8	Warning—Hazardous Voltage: Disconnect Before Servicing
9	Lock Stabilizing Feet
10	Forklift Pocket: Not a Step
11	Notice—Adjust Four Stabilizers
12	Warning—Electric Shock Hazard

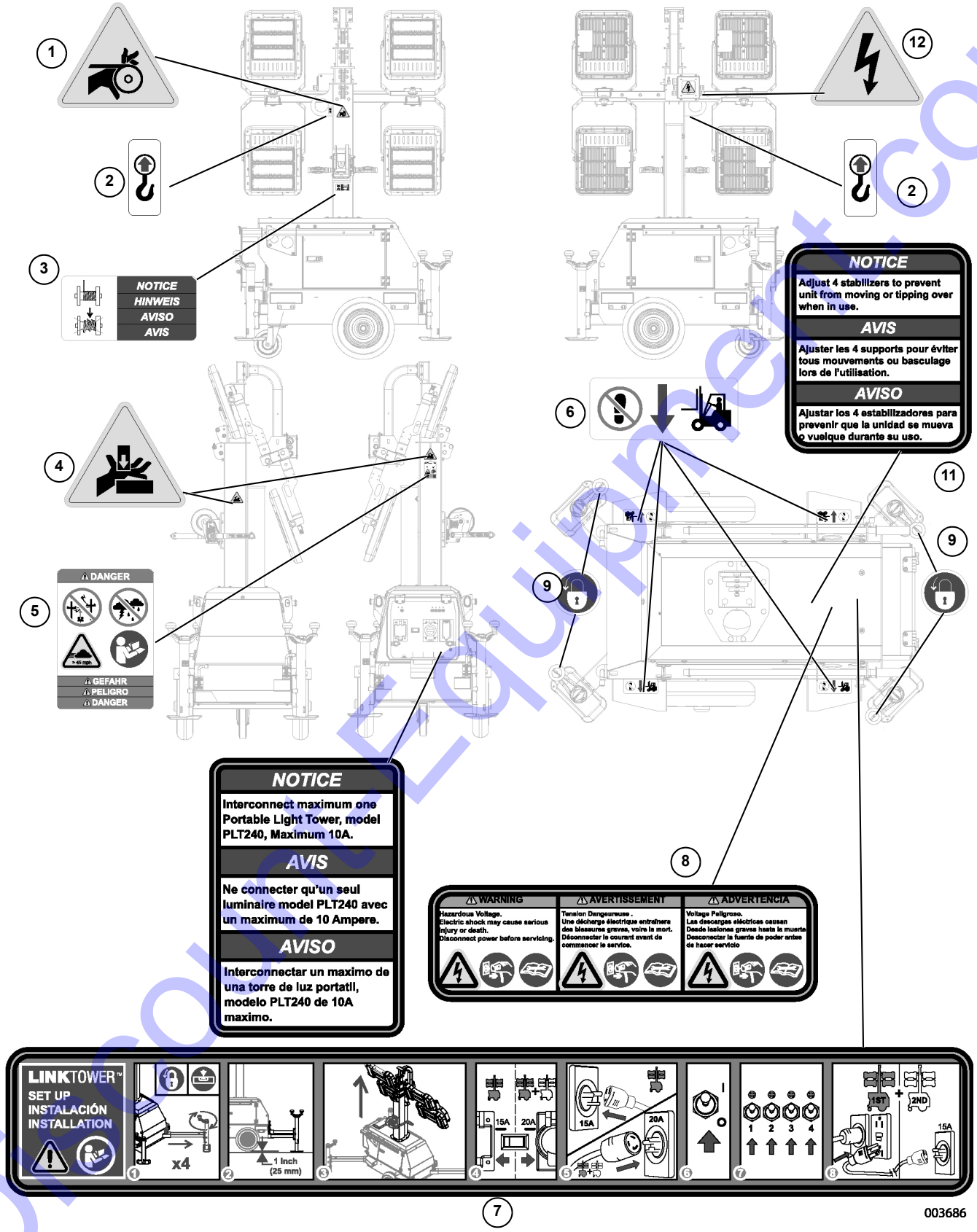

Figure 1-1. Decal Locations

Section 2: General Information

Specifications

DESCRIPTION	PLT240-LED
Dimensions	
See Unit Dimensions .	
Weights	
Operating Weight	558 lbs (252.6 kg)
Lighting	
Lighting Type	Light-Emitting Diode (LED)
LED Driver	(4) Mean Well HLG-320H-30A
Lumens	122,000
AC Distribution	
Circuit Breaker Size	15A / 20A Main Breaker
Amperage Selection	15A / 20A
120V-20 Amp GFCI Receptacle	1
Power Selection Switch	1
120V-20 Amp Twist Lock Inlet	1
120V-15 Amp Inlet	1
Chassis	
Number of Axles	1
Tire Size	3.5 x 8 in. (89 x 203 mm)
Locking Caster Size	6 in. (152 mm)
Maximum Cargo Capacity	180 in. (81.7 mm)
<i>Specifications are subject to change without notice.</i>	

Unit Serial Number Locations

See **Figure 2-1** to locate the unit ID tag on the unit. Important information, such as the unit serial number, model number, and tire loading information are found on these tags. Record the information from these tags so it is available if the tags are lost or damaged. When ordering parts or requesting assistance, you may be asked to provide this information.

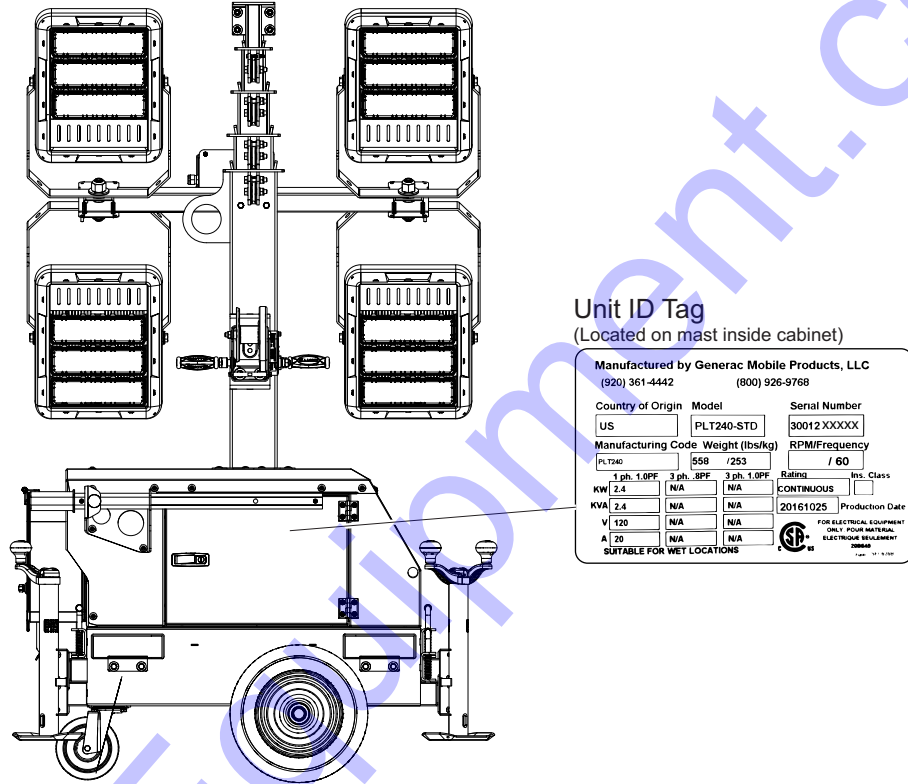
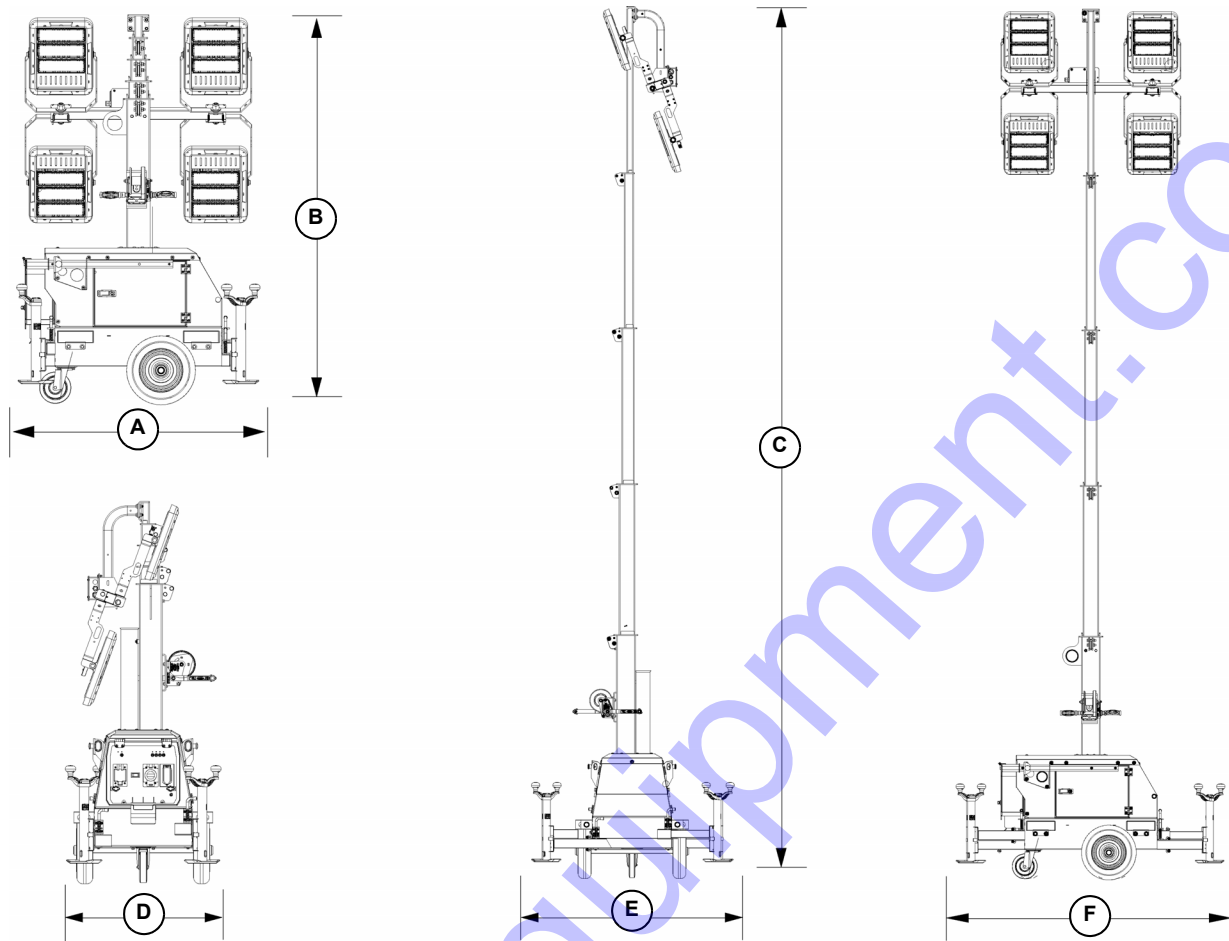

Figure 2-1. Unit Serial Number Locations

003622

Unit Dimensions



003440

Figure 2-2. Unit Dimensions

	A	B	C	D	E	F
PLT240	48.5 in. (1.23 m)	77.5 in. (1.96 m)	16 ft. (4.88 m)	31.5 in. (0.80 m)	57 in. (1.45 m)	74 in. (1.88 m)

Specifications are subject to change without notice.

Component Locations

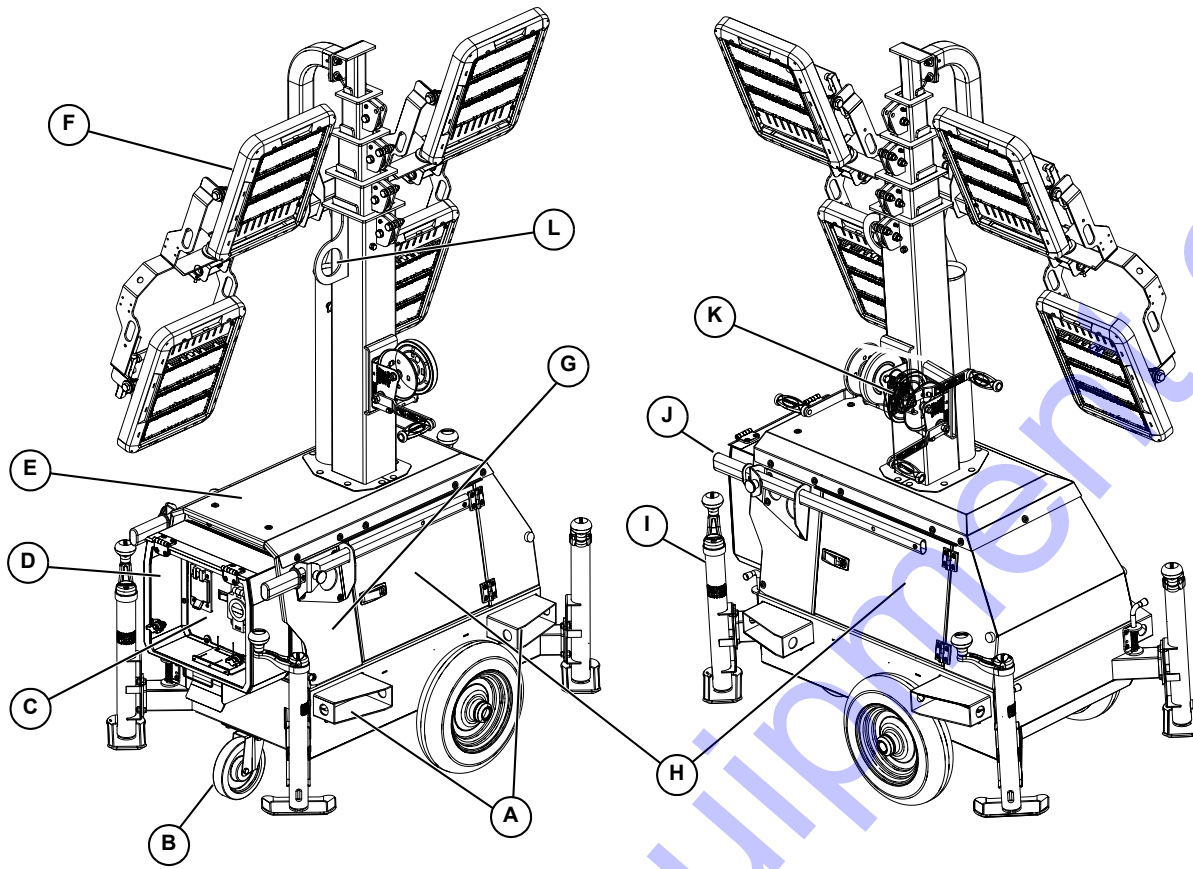

003443

Figure 2-3. Component Locations—Front and Left Side

- | | |
|---|--|
| A. Forklift pockets / tie-down locations | G. LED Drivers (inside cabinet) |
| B. Swiveling caster (lockable) | H. Lockable storage access door (2) |
| C. Control panel | I. Outrigger and jack (4) |
| D. Water protection shield | J. Handle (2) |
| E. Quick start guide | K. Winch |
| F. LED fixtures (4) | L. Lifting eye |

Control Panel

IMPORTANT NOTE: If the control panel is ever removed, replace the gasket behind control panel and the gasket between the water ingress cover and control panel.

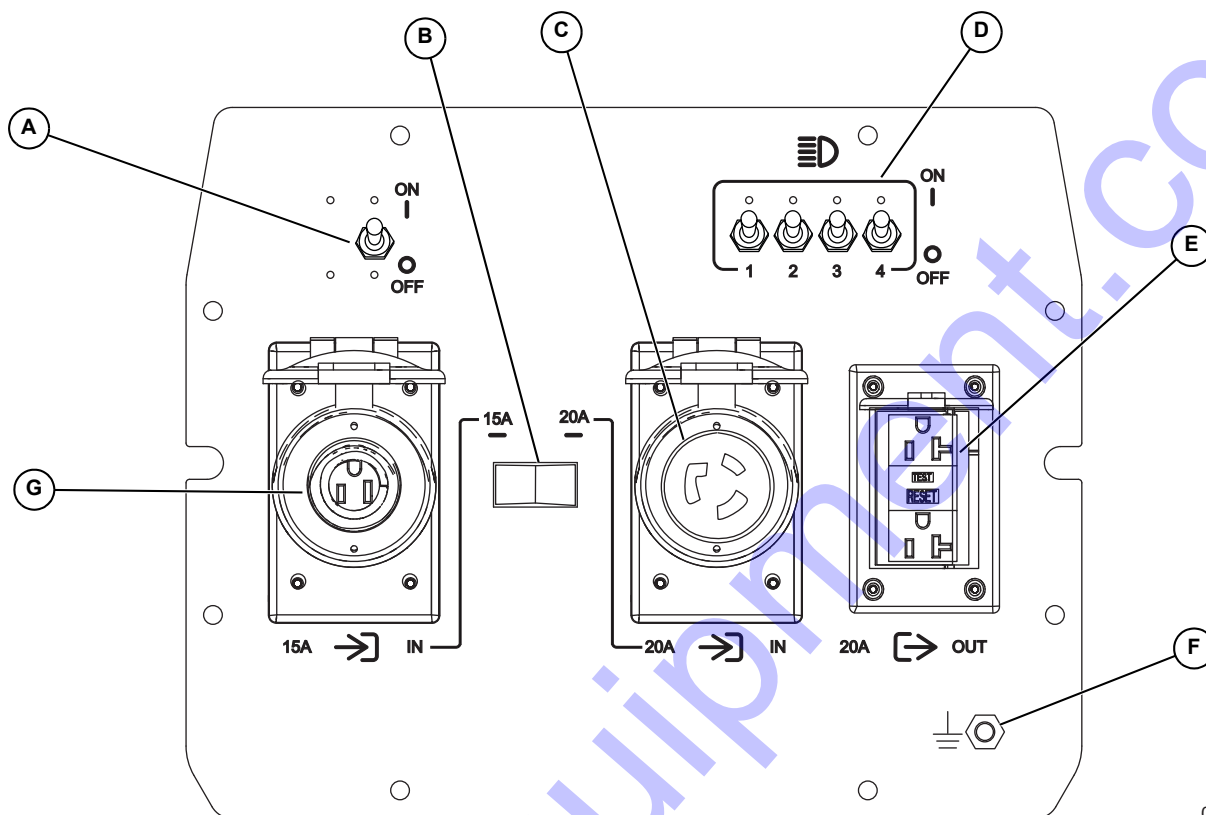

003389

Figure 2-4. Control Panel

Control Panel Components and Functions

(A) Main circuit breaker

Resettable main circuit breaker for the LED lights and 120V/20A GFCI receptacle.

(B) Input power selector switch

Allows the operator to select the input (shore power) source.

- Choose the 15A setting if the unit will be operated as a stand-alone light source.
- Choose the 20A setting if auxiliary equipment or a second PLT240 will be connected to the unit.

See (C) and (G) for more information.

(C) 120VAC-20A plug (shore power input)

Provides a connection point for 120VAC-20A shore power input to the LED lamps and GFCI receptacle. Requires NEMA L5-20P connection.

(D) Mast light circuit breakers

Individual circuit breakers for the LED light fixtures.

(E) 120VAC/20A GFCI convenience receptacle (5-20R)

Customer convenience receptacle for use in connecting auxiliary equipment. Includes a Ground Fault Circuit Interrupter (GFCI) test and reset button. Requires NEMA 5-20P or 5-15P connection.

(F) Electrical ground connection (Optional)

An electrical grounding stud for connecting an earth ground to the unit if required. Follow local, state, or National Electrical Code (NEC) guidelines.

(G) 120VAC-15A plug (shore power input)

Provides a connection point for 120V-15A input power for the LED lamps only. NEMA 5-15 plug. Requires NEMA 5-15P connection.

Internal Storage

See [Figure 2-5](#). The interior of the cabinet can be used for storing nonflammable items such as shore power cords, small equipment, or tools when the unit is not in operation. Locking doors (A) on each side of the cabinet provide access to the cabinet interior.

NOTE: Cabinet is not waterproof.

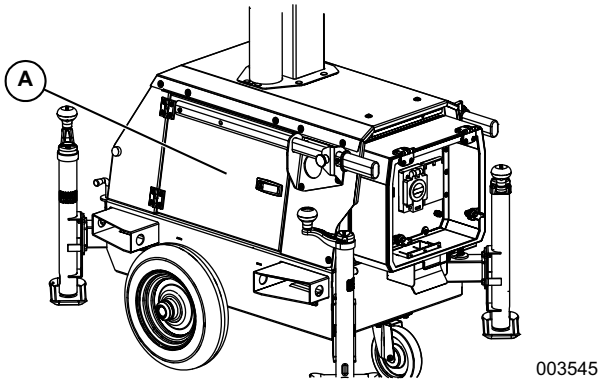



Figure 2-5. Internal Storage



WARNING
Hot Surfaces. When operating machine, do not touch hot surfaces. Keep machine away from combustibles during use. Hot surfaces could result in severe burns or fire.

(000108)

The LED drivers are mounted inside the cabinet behind a heat guard at the back of the unit (control panel end). The drivers become very hot during operation. Use care when adding or removing items from internal storage, and avoid touching the heat guard. Verify heat guard vents are clear of obstructions.

Lifting and Transporting

This unit is equipped with a lifting eye and forklift pockets for lifting the unit on and off a transporting vehicle. Wheels and handles are provided for manually maneuvering the unit at the work site.

IMPORTANT NOTE: This unit is not designed to be towed. Never attempt to tow this unit behind a vehicle.

Lifting the Unit

NOTE: Always remain aware of people and objects around the unit while preparing, maneuvering, and lifting the unit.

1. Verify the equipment being used to lift the unit is in good condition and has sufficient capacity. For approximate weights, refer to [Specifications](#).
2. Verify the mast is completely lowered.
3. Verify the outriggers and jacks are fully retracted.

4. Close and lock both access doors and the control panel.
5. See [Figure 2-6](#). To lift the unit, use one of the following methods:
 - Attach slings, chains or hooks directly to the central lift point (A). Verify the LED fixtures will not be damaged when lifting.
 - Use a forklift. Approach the forklift pockets (B) only from the side as shown. Avoid approaching the unit at an angle, as this can permanently damage the forklift pockets, wheels, or cabinet. Make sure any obstructions are clear of the forklift tines before lifting.

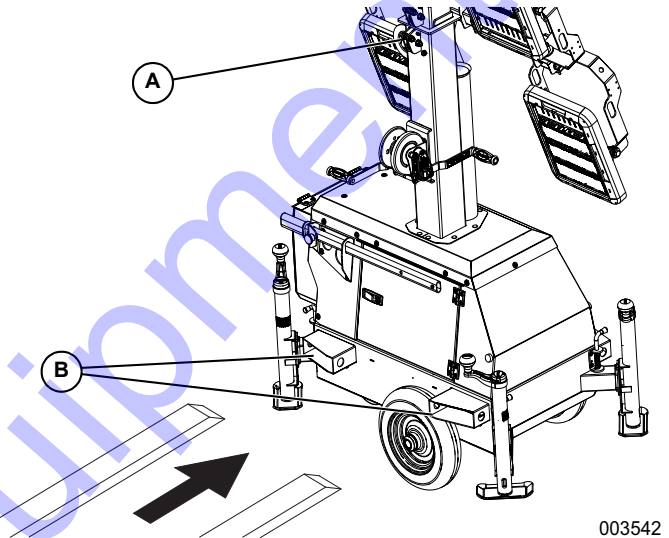

Figure 2-6. Lifting The Unit

Transporting the Unit

See [Figure 2-7](#). Wheelbarrow-style handles (C) are provided for maneuvering the unit at the work site. Pull the spring-loaded knobs (D) and fully extend each handle. Then release the spring-loaded knobs to lock the handles in place.

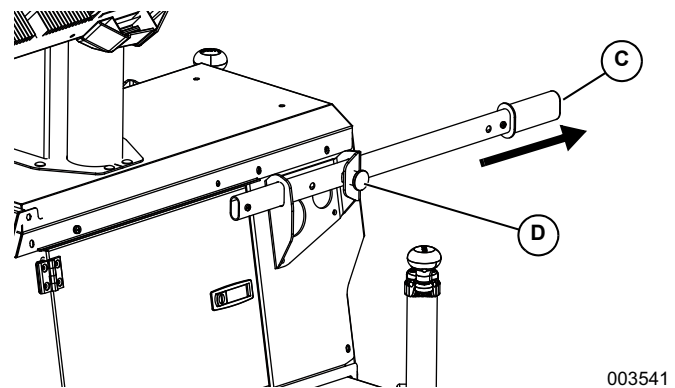

Figure 2-7. Extending the Handles

See [Figure 2-8](#). The chassis is equipped with a swiveling caster at the rear. Step on the brake (E) to lock the caster and prevent the wheel from rotating. Raise the brake to unlock the caster.

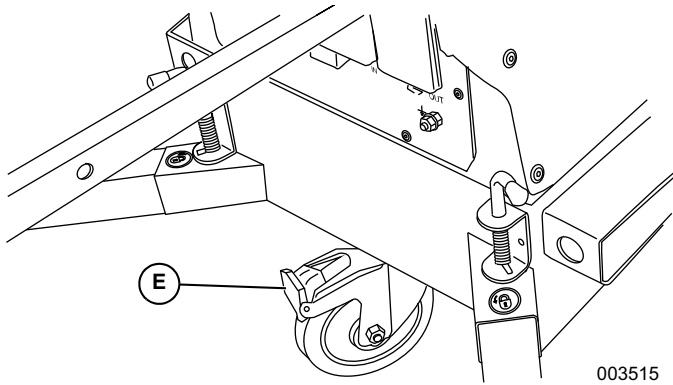

Figure 2-8. Swiveling Caster

Tying the Unit Down

When securing the unit for transportation, verify the equipment being used to fasten the unit is in good condition and has sufficient strength to hold the unit in place during transport.

See [Figure 2-6](#). Tie-down straps, ropes, or chains may be passed through the forklift pockets (B). The holes in the forklift pockets may also be used to secure the unit for transport.

Section 3: Operation

Operation Configuration

Before setting up the unit, determine if the unit will operate as a standalone light tower, or if export power will be required.

If the unit will be operated as a standalone light tower, either the 120V-15A or 120V-20A input power plugs can be used.

If export power is required, or a second link tower will be connected (via the 120V GFCI receptacle), 120V-20A input power is required.

NOTE: Shore power cords are not included with this unit and must be supplied by the end user. See [Table 1](#) for recommended cable size and length.

Table 1 - Recommended Shore Power Cable Size and Length

Suggested Power Cables and Lengths
50 ft. (15.2 m) 10/3—(L5-20P – L5-20R)
100 ft. (30.5 m) 12/3—(5-15P – 5-15R)
Maximum Distance - One LINK Tower
400 ft. (121.9 m) cable size 10/3—(L5-20P – L5-20R)
OR
300 ft. (91.4 m) cable size 12/3—(5-15P – 5-15R)
Maximum Distance - Two LINK Towers
300 ft. (91.4 m) cable size 10/3—(L5-20P – L5-20R) to first LINK Tower (first LINK Tower must be powered by 20A circuit)
AND
200 ft. (61 m) cable size 12/3—(5-15P – 5-15R) to second LINK Tower

LED Lights Only

Connect the unit to either a 120VAC-15A supply or 120VAC-20A supply using either input power plug.

LED Lights and Auxiliary Power

1. Connect the unit to a 120VAC-20A supply using the NEMA L5-20 plug.
2. Connect auxiliary equipment to the 120VAC GFCI convenience receptacle.



⚠ DANGER

Asphyxiation. Do not connect any engine-powered equipment or fired air heaters to the convenience receptacle(s), even with proper ventilation. Carbon monoxide, if not avoided, will result in death or serious injury. (000353)

Light Tower Setup



⚠ DANGER

High Voltage. Verify area above unit is clear of overhead wires and obstructions. Contact with high-voltage power lines will result in death or serious injury. (000260a)



⚠ WARNING

Personal Injury. Do not set-up or operate unit in high winds. Doing so could result in death, serious injury, property, or unit damage. (000345)

IMPORTANT NOTE: Unit wind rating is 45 mph.



⚠ WARNING

Electrocution. Do not set up or operate this unit if severe weather is expected. Lightning strikes can kill or cause severe injury even if you are not touching the unit. (000296)

1. For maximum light coverage, position the unit at ground level or in a spot higher than the area being illuminated by the lamps.

NOTE: The mast extends up to 16 ft (4.88m).

2. Place the unit on firm ground that is relatively flat (less than 5° grade). Use the handles to rotate the unit until the lights face the desired direction.
3. Lock the swiveling caster.
4. Return the handles to the stored position.
5. A grounding stud is located on the control panel. For grounding requirements, follow local, state, oil and gas or petrochemical plant grounding, MSHA, OSHA, CSA, IEC, IEEE, NFPA, ABS Marine and Maritime guidelines as applicable.

- See **Figure 3-1**. Pull the locking pins (A) on the four outriggers (B) and pull each outrigger out until the spring loaded locking pin snaps back into place.

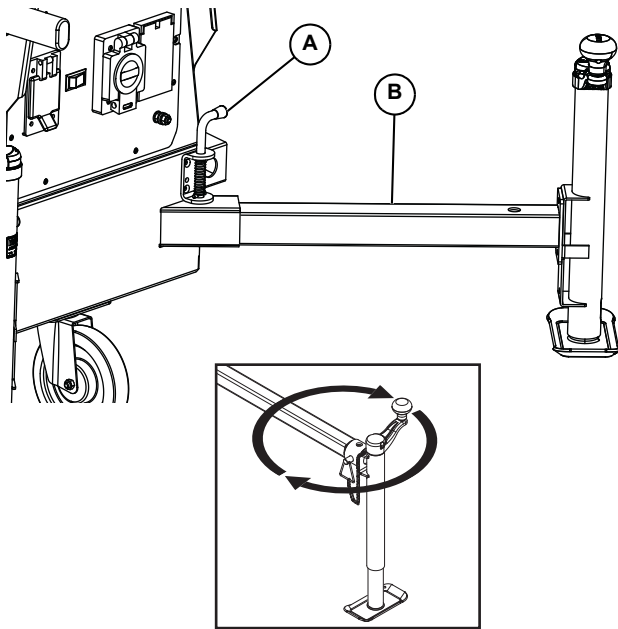

Figure 3-1. Set Up Outriggers and Jacks

- Rotate each jack handle clockwise to start leveling the unit. Adjust all four jacks by rotating their handles clockwise until the wheels and caster are not touching the ground.
- Before raising the mast, it may be necessary to adjust the LED fixtures. The LED fixtures may be adjusted up, down, left or right by simply aiming them in the desired direction.

Raising the Mast

IMPORTANT NOTE: The mast is intended for use **ONLY** to support the LED fixtures. Do not use the mast as a hoist or for any other purpose.

- Set up and level the unit. See **Light Tower Setup**.

WARNING

Tipping hazard. Extend the outriggers and level the unit before raising the mast. Keep the outriggers extended while the mast is up. Failure to do so could cause the unit to tip and fall and could result in death or serious injury.

(000266)

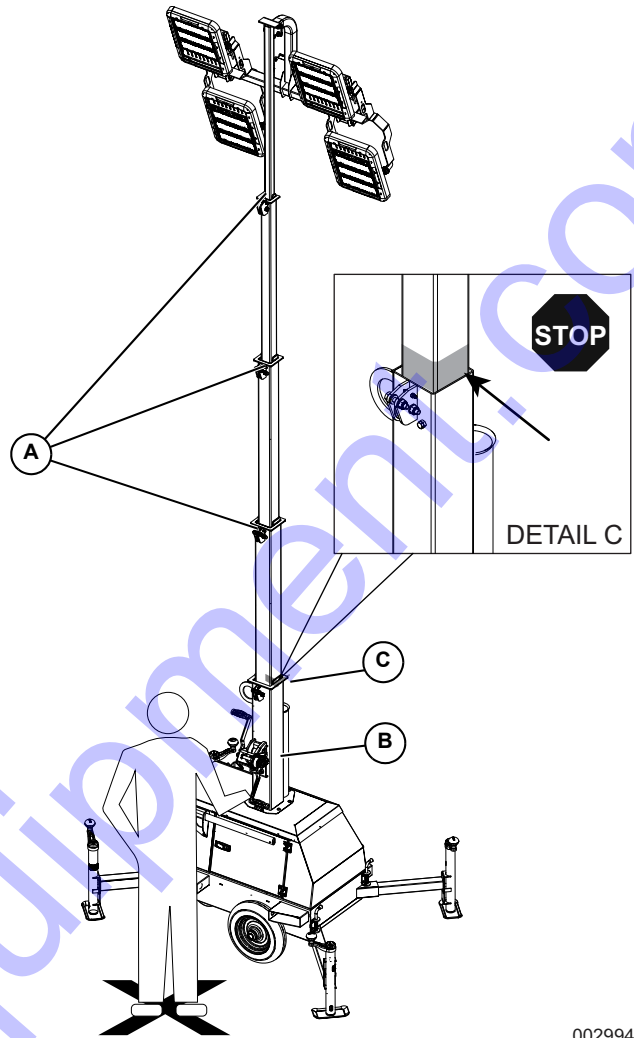

Figure 3-2. Pulley Locations

- See **Figure 3-2**. Check the mast cables for excessive wear or damage. Verify the cables are properly centered in each pulley (A). Check the electrical cord for damage.
- Stand, facing the winch, at the location indicated with the black "X" in **Figure 3-2**.
- Use the winch (B) to slowly extend the mast, making sure that the coiled electrical cord is extending at the top sections of the mast. STOP extending the mast when the colored mark (C) on the second mast section is visible as seen in Detail C.

WARNING

Personal Injury. Stop immediately if the mast hangs up or the winch cable develops slack. Excess slack could cause the mast to collapse, resulting in personal injury or equipment damage.

(000265)

IMPORTANT NOTE: Contact a Generac Mobile Products Authorized Dealer immediately if the mast hangs up or the winch cable develops slack.

⚠ WARNING

Machine damage. Do not extend the mast beyond the colored mark. Overextension can stretch or break electrical cables or winch cables, and may damage mast hardware.

(000372)

⚠ WARNING

Personal injury. Use caution when winding winch cable. Failure to do so could result in serious injury.

(000391)

5. See [Figure 3-3](#). Verify cable winds evenly around winch drum as shown (A) to prevent cable damage.

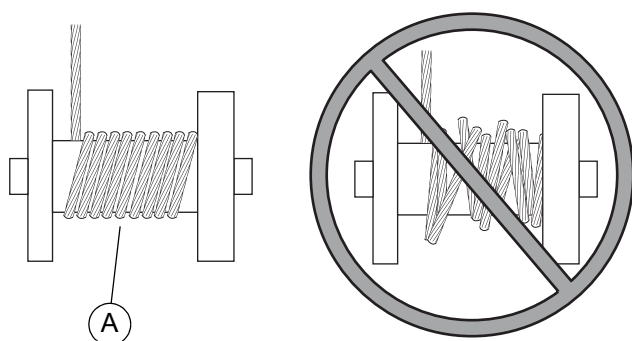

Figure 3-3. Winch Cable Alignment

Prestart Checklist

Before starting the unit, all items in the prestart checklist must be completed.

**⚠ WARNING**

Consult Manual. Read and understand manual completely before using product. Failure to completely understand manual and product could result in death or serious injury.

(000100a)

- Verify all maintenance procedures are up to date. For more information, refer to [General Maintenance](#) and [Basic Maintenance Schedule](#).
- Verify the unit is level.
- Verify the unit is dry. Look for water inside or near the unit; dry if needed.
- For grounding requirements, follow any local, state, oil and gas or petrochemical plant grounding, MSHA, OSHA, CSA, IEC, IEEE, NFPA, ABS Marine and Maritime guidelines as applicable.
- Verify the main breaker switch is OFF (O).
- Verify all circuit breakers are OFF (O).
- Inspect all electrical cords; repair or replace any that are cut, worn, or bare.
- Verify all winch cables are in good condition and centered on each pulley. Do not use if cables are kinked or beginning to unravel.
- Verify all covers and guards are in place and properly secured.
- Verify cords are routed properly through the water protection shield.
- If using 20A shore power, verify convenience receptacle is functional.

Turn Unit ON



⚠ DANGER

Electrocution. DO NOT use the unit if electrical cord is cut or worn through. Doing so will result in death or serious injury.

(000263a)

1. Plug in any equipment or another LINK tower.
2. Press the plug power selection switch to select either 15A or 20A power source. Switch position MUST match the connected input source.
3. Connect a 20A or 15A shore power cord, depending on plug power selection switch position and input source from previous step.
4. Turn the main breaker switch ON.
5. Turn each mast light circuit breaker ON. The LED lamps will illuminate.
6. Start auxiliary equipment (if powered by the 20A inlet).

NOTE: It may be necessary to leave some lights off if the export current exceeds 12A.

Turn Unit OFF

Check with personnel using lights and auxiliary power supplied by the unit and let them know the power is going to be turned off. Verify the power shutdown will not create hazards by turning off equipment that may be in use (lights, tools, etc.).

1. Turn off and disconnect any auxiliary equipment.
2. Switch lights OFF using the individual mast light breakers.
3. Switch main breaker OFF (O).
4. After the unit shuts down, disconnect the shore power cord.

Lowering the Mast

1. Shut down the lights. See [Turn Unit OFF](#).
2. Lower the mast.
3. Use the winch handles to lower the mast to its lowest position. Verify the electrical cord does not get caught in, or pinched by, the mast while it is being lowered.

⚠ WARNING

Personal Injury. Stop immediately if the mast hangs up or the winch cable develops slack. Excess slack could cause the mast to collapse, resulting in personal injury or equipment damage.

(000265)

IMPORTANT NOTE: Contact an Generac Mobile Products Authorized Dealer immediately if the mast hangs up or the winch cable develops slack.

Long-Term Storage

Perform the following steps if the machine is to be stored for an extended period (for example, more than one year).

1. Verify all circuit breakers are OFF (O).
2. Verify the unit is unplugged.
3. Lower the mast.
4. Retract the outriggers and handles.
5. Clean the unit inside and out.
6. Close and lock the storage access panels.
7. Store the unit indoors, if possible, in a secure, dry location.

Perform a visual inspection of all electrical connections, LED lights, winch cables, and mast before returning the unit to service.

Section 4: Maintenance

Daily Walk-Around Inspection

Perform a walk-around inspection of the unit every day before starting the unit. Look for conditions that could hinder performance or safety, such as (but not limited to) damaged or missing parts and hardware, and loose or broken electrical connections.



Equipment Damage. Failure to perform a daily inspection could result in damage to the unit.

(000306)

General Maintenance

Poorly maintained equipment can become a safety hazard. In order for the equipment to operate safely and properly over a long period of time, periodic maintenance and occasional repairs are necessary. **DO NOT** perform routine service unless all electrical components are OFF.

Regular maintenance will improve performance and extend engine/equipment life. Generac Mobile Products LLC recommends all maintenance work be performed by an Generac Mobile Products Authorized Dealer.

Preparing for Service

Before servicing the unit, always follow the instructions listed below.

1. Verify the main breaker switch and lamp switches are OFF.
2. Disconnect shore power from the unit.
3. Disconnect linked units.
4. Attach a DO NOT USE sign to the control panel. This will notify everyone that the unit is being serviced and will reduce the chance of someone inadvertently trying to start the unit.

Cleaning the Unit

Always clean the unit after each use to remove dust, grease, mud, or spilled fuel or oil. Use soft, clean rags to wipe the cabinet exterior and control panel. Low-pressure compressed air (less than 40 PSI [276 kPa]) can also be used to remove dust and debris from the cabinet interior.

This unit contains sensitive electronic components that can be damaged by high pressure, heat and moisture. Do not wash the unit with a high pressure hose or power washer. Water may enter the cabinet and collect in the control panel or other electrical parts, causing damage.

Inspecting the Unit

- If the unit is stored outside, check for water inside the cabinet and control panel cover before each use. If wet, dry the unit thoroughly before starting.
- Inspect condition of electrical cords. **DO NOT** use the unit if insulation is cut or worn through.
- Verify winch cables are in good condition and centered on each pulley. **DO NOT** use a cable that is kinked or starting to unravel.
- Verify the wheels and locking caster are present and in serviceable condition.

Basic Maintenance Schedule

Use [Table 4-1](#) and [Table 4-2](#) as guides for regular maintenance intervals. For additional guidance, contact a Generac Mobile Products Authorized Dealer.

Table 4-1. Basic Maintenance Guide

Item	Daily
Check Tires for Wear	◆
Check All Electrical Connections	◆
Inspect Light Tower Winch For Proper Operation	◆

Winch Use, Operation and Maintenance

Prior to Use

- Inspect winch cable and replace if damaged.
- Check mounting hardware for proper tightness and tighten if necessary.
- Gears, ratchet pivot point and shaft bushings must be kept lubricated with a thin film of oil or grease.

Operation

Raising the Mast:

1. The cable must be securely fastened to the winch drum.
2. Always be sure the cable is undamaged. Contact Generac Mobile Products to order a replacement cable if necessary.
3. Referring to the LIFT/LET DOWN decal on the winch, rotate handle according to the specified direction to lift. The ratchet MUST make a loud clicking sound while winding the cable.

Lowering the Mast:

Referring to the LIFT/LET DOWN decal on the winch, rotate handle according to the specified direction to lower. No clicking will be heard while lowering the mast because the automatic brake system is activated.

Maintenance

The following procedures should be performed at least annually:

1. Lubricate winch gears and bushings. Apply a thin film of grease to the gear teeth, and oil the bushings as needed.
2. Lubricate the ratchet pawl pivot point with a thin oil.

NOTE: Do not get oil or grease on the brake mechanism.

Winch Mechanical Brake

The mechanical brake generates heat when loads are lowered and the wire cable is powered out. Care must be taken to avoid overheating the mechanical brake.

Whine or chatter associated with a new mechanical brake is normal and typically disappears with use.

Overheating the mechanical brake may result in permanent damage to, or failure of, the brake. Replace any damaged brake components before resuming use of the winch.

Table 4-2. Winch Preventative Maintenance Schedule

Maintenance Activity	After First Operation	Before Each Use	Semi-Annually
Check Fasteners	◆		◆
Clean And Grease Brake Assembly			◆
Visually Check Winch And Control	◆	◆	◆

Jack Maintenance

Before each use, check each jack foot for damage and remove any mud or debris. The jacks must be clean and in good operating condition to properly support the unit.

Wheel Maintenance

Before each use, check each wheel for cuts, damage, cracks, or embedded objects. Verify all fasteners are present and tight.

Section 5: Troubleshooting

Troubleshooting the Lights



⚠ DANGER

Electrocution. Potentially lethal voltages are present in this equipment. Render the equipment safe before attempting repairs or maintenance. Failure to do so will result in death or serious injury.

(000343)

IMPORTANT NOTE: Only a qualified electrician should troubleshoot or repair electrical problems occurring in this equipment.

Problem	Possible Cause	Solution
LED Mast Lights Do Not Turn On	Extension cord too long	Reduce length or increase gauge of extension cord. See Table 1 in Section 3.
	Faulty electrical connection	Verify connectors within following sections are properly seated and there are no loose connections: <ul style="list-style-type: none"> • Mast junction box • 12 pin connector • LED drivers (4) • Mast light circuit breakers (4) • Input power selector switch • Main breaker switch
	Faulty main breaker switch	Replace main breaker switch
	Faulty mast light circuit breaker(s)	Replace mast light circuit breaker(s)
	Faulty LED driver	Verify driver input voltage from light switch is 120VAC ±10VDC. If output voltage from LED Driver (at 12 pin connector) is less than 24VDC, replace LED driver.
	Supply power breaker tripped	Reset supply power breaker.
LED Mast Lights are Flashing	Extension cord gauge too small	Use larger extension cord.
	LED driver overheated	Leave light off for a few minutes to reset protection; then restart lights. Verify nothing is obstructing airflow to driver. Check for accumulated dust or dirt on driver; remove using clean, dry cloth.
	Voltage is too low	Raise voltage to 90VAC
Main Breaker Switch Trips when Applying Load	Connected load (through GFCI) too large	Reduce size of connected load or reduce the number of lights in use.

Section 6: Wiring Diagrams

AC Wiring

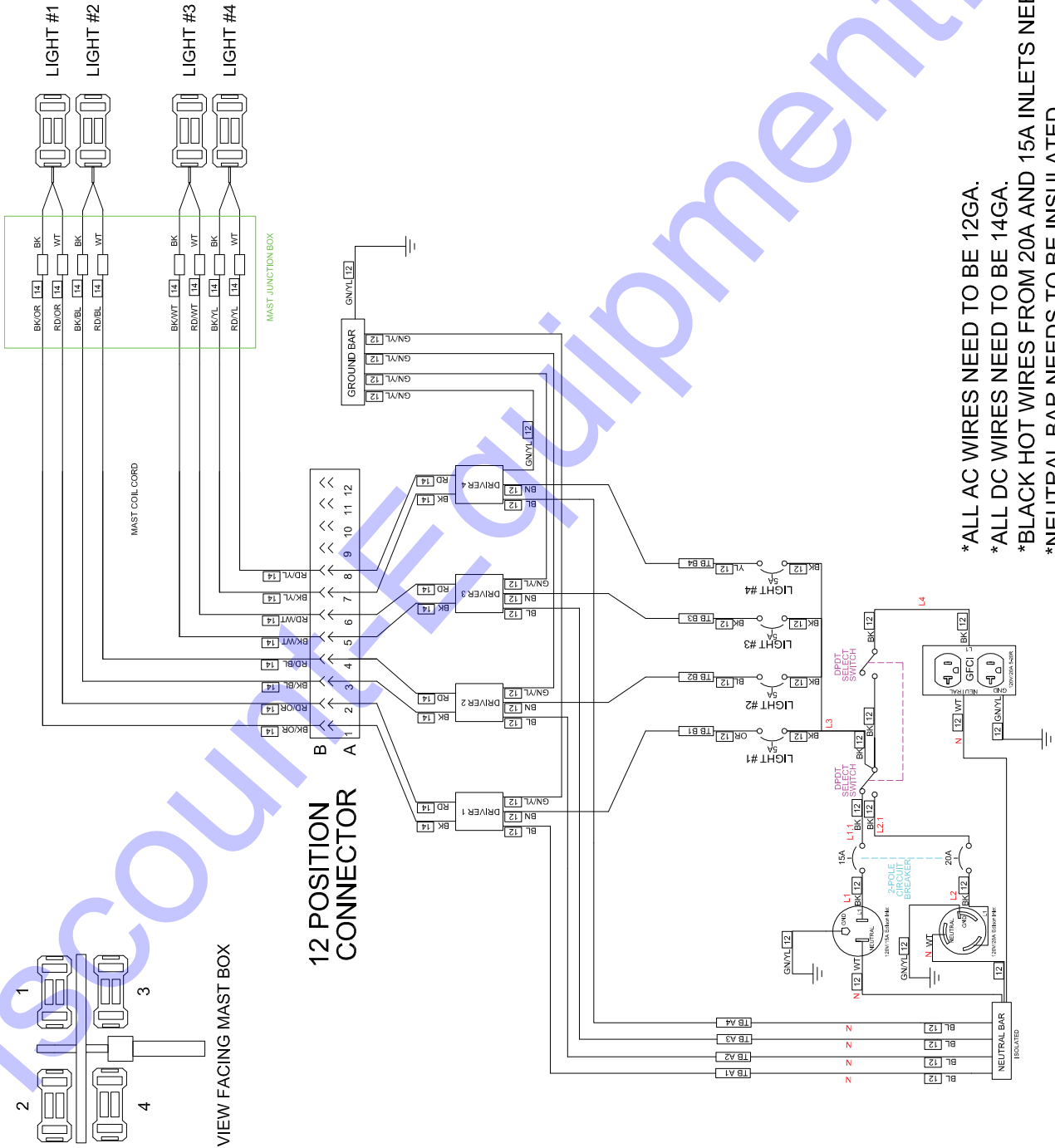

- *ALL AC WIRES NEED TO BE 12GA.
- *ALL DC WIRES NEED TO BE 14GA.
- *BLACK HOT WIRES FROM 20A AND 15A INLETS NEED TO BE LABELED.
- *NEUTRAL BAR NEEDS TO BE INSULATED.



www.discount-equipment.com

Part No. 54800 Rev. D 05/09/18
©2018 Generac Mobile Products, LLC
All rights reserved.
Specifications are subject to change without notice.
No reproduction allowed in any form without prior written
consent from Generac Mobile Products, LLC.

GENERAC

**MOBILE
PRODUCTS**