

AIRMAN

PC

PARTS CATALOG

部 件 样 本

SCREW COMPRESSOR

螺 杆 压 缩 机

PDS185S-6C2



www.discount-equipment.com

HOKUETSU INDUSTRIES CO., LTD.

Discount Equipment

Discount-Equipment.com is your online resource for commercial and industrial quality parts and equipment sales.

Locations:

Florida (West Palm Beach): [561-964-4949](tel:561-964-4949)

Outside Florida TOLL FREE: [877-690-3101](tel:877-690-3101)

Need parts? Check out our website at www.discount-equipment.com

Can't find what you need?

Click on this link: <http://www.discount-equipment.com/category/5443-parts/> and fill out the request form.

Please have the machine model and serial number available in order to help us get you the correct parts. One of our experienced staff members will get back to you with a quote for the right part that your machine needs.

We sell worldwide for the brands: Genie, Terex, JLG, MultiQuip, Mayco, Toro/Stone, Diamond Products, Magnum, Airman, Mustang, Power Blanket, Nifty Lift, Atlas Copco, Chicago Pneumatic, Allmand Brothers, Essick, Miller Spreader, Skyjack, Lull, Skytrak, Tsurumi, Husquvarna/Target, Whiteman-Concrete/Mortar, Stow-Concrete/Mortar, Baldor, Wacker, Sakai, Snorkel, Upright, Mi-T-M, Sullair, Neal, Basic, Dynapac, MBW, Weber, Bartell, Bennar Newman, Haulotte, Ditch Runner, Blaw-Knox, Himoina, Best, Buddy, Crown, Edco, Wyco, Bomag, Laymor, Terremite, Barreto, EZ Trench, Takeuchi, Basic, Bil-Jax, Curtis, Gehl, Heli, Honda, ICS/PowerGrit, Puckett, Waldon, ASV, IHI, Partner, Imer, Clipper, MMD, Koshin, Rice, Gorman Rupp, CH&E, Cat Pumps, Comet, General Pump, Giant, AMida, Coleman, NAC, Gradall, Square Shooter, Kent, Stanley, Tamco, Toku, Hatz, Kohler, Robin, Wisconsin, Northrock, Oztec, Toker TK, Rol-Air, Small Line, Wanco, Yanmar

New Equipment - Used Equipment - Rental Equipment - Parts and Accessories

Discount Equipment

www.discount-equipment.com

561-964-4949

Parts: wbparts@Discount-Equipment.com

Sales: info@Discount-Equipment.com

FOR MODEL
适用机型

MODEL 机型	SER. NO. 适用机号
PDS185S-6C2	B4-6C20051~

NOTICE

1. This parts catalog contains all the parts and assemblies of "AIRMAN" brand products. The complete unit is divided into several parts groups, the details of which are clearly illustrated, and completely listed. So desired part number, name and quantity can be easily determined referring to Ref.No.

2. When you place order for service parts, please be sure to advise us of the following information.

- (1) Part number.
- (2) Quantity required.
- (3) Part name.
- (4) Model name and Serial number.

3. How to read parts catalog.

(1) Ref.No.

Reference number (Ref.No.) is to be used for locating the part number and name from the illustrations. (However some parts such as bolts and nuts etc., are not illustrated but their reference numbers only listed.)

Ref.No. 1, 1-1, 1-2, shows history of part modifications; namely ref.No. 1 changed to No. 1-1 and then 1-2.

Example: Ref.No.

	Part No.
1.	21101 00101
1-1.	21101 00103

(2) Part No.

Every part has its own proper number. Even if a part has the same shape as an other part and if its number different, it is not interchangeable at all in many cases.

(3) Interchangeability

A. B. C. D. Q. X. Y. and Z. in column "Interchangeability" show the following.

A: A new part is replaceable with an old part, but the old part is not replaceable with the new one.

B: Not interchangeable.

C: Disused.

D: Newly added.

Q: Quantity per unit changed.

X: Included in this set of parts, this part is not used for this model.

Y: Part to be selected.

Z: This part can not be supplied as an individual part.

(4) Part name

Every part has its own proper name.

(5) Q'ty

The number shown in the column of Q'TY indicates the quantity of parts used per one unit machine.

(6) Applicable Ser. No. (Serial Number)

Ser.No. shows the machine number to which the part is applicable.

Month and year stated in column "Ser.No." show the month and year from which the part is applicable.

4. Abbreviations and marks used in this catalog.

ass'y	assembly	L	Length
C/H	Change column	o & p	overrun & parking brake
Comp.	Compressor	OPT.	Option
Const.	Consisting of	Press.	Pressure
Cont.	Control	SPC/S.	Special specifications
Cyl.	Cylinder	STD.	Standards
Eng.	Engine	T or t	Thickness
EXP.	Export	w.	with
Incl.	Including	w/o	without

5. HOW TO READ MODELS

Example: P D S □ 1 2 5 S □ - 5 B 1
 ① ② ③ ④ ⑤ ⑥ ⑦ ⑧ ⑨

- | | |
|--|---------------------------------|
| ① P D : PORTABLE DIESEL ENGINE | ⑤ S : SILENT TYPE and PROPANE |
| SD : STATIONARY DIESEL ENGINE | GAS ENGINE SILENT TYPE |
| SG : STATIONARY GAS ENGINE | T : CITY-GAS ENGINE SILENT TYPE |
| SM : STATIONARY SNOW MACHINE | w/o : UNSILENCED TYPE |
| ② R : SLIDING VANE | ⑥ C : AFTERCOOLER TYPE |
| S : SCREW(OIL-INJECTION) | D : DRY AIR TYPE |
| D : SCREW(OIL-FREE) | R : IN LINE PUMP TYPE |
| ③ w/o : 0.69MPa or 0.70MPa | W : WATER-COOLED TYPE |
| E : 0.86MPa | w/o : STANDARD TYPE |
| F : 1.03MPa | ⑦ 3 : SKID-MOUNTED TYPE |
| G : 1.18 to 1.37MPa | 4 : TRAILER-MOUNTED TYPE |
| H : 1.72MPa | 5 : BOX |
| J : 2.07MPa | 6 : WIDE BODY |
| K : 2.41 to 2.45MPa | w/o : OTHERS |
| ④ 75 : ENGINE OUTPUT (kW) <SDD, SDSG ONLY> | ⑧ MODEL CHANGE MARK |
| 125 : Free air delivery(cfm) | ⑨ VARIATION MARK |

NOTE : We are always engaged in improving our products. So there may be some changes of the product which are not yet mentioned in this parts catalog.

Therefore, in necessary case, we issue a revision in which such changes are added.

When you have any question on the parts catalog, please ask your nearest dealer or directly us.

使用 说 明

1. 本部件样本记载了各部构造的部件分解示意图。根据各部件的指示编号，可以知道各部件的编号、名称以及一台机器所需的数量。
2. 订购部件时，请通知以下内容：
 - (1) 部件编号 (Part No.)
 - (2) 必要数量 (Q'ty)
 - (3) 部件名称 (Part Name)
 - (4) 机器型式 (Model)和机器编号 (Ser. No.)
3. 本部件样本的使用方法：
 - (1) 指 示 编 号 (Ref. No.)

起到从示意图中找出部件名称和部件编号的作用。
(请注意，部分示意图中未表示螺栓、螺母等小部件，只是标注了指示编号。)
指示编号一栏中的1, 1-1, 1-2, ……，表示部件的变更过程。
(变更过程：指示编号1的部件先变更为1-1，其次再变更为1-2)
 - (2) 部 件 编 号 (Part No.)

表示各部件的特定编号。
请注意，即使部件的形状相同，但是，如果部件的编号不相同，则不具备互换性。
 - (3) 互 换 性 (Interchangeability)

互换性一栏中记载的符号意义如下：
A：新部件可以代替旧部件使用，而旧部件不可以代替新部件使用。
B：新、旧部件之间没有互换性。
C：废止
D：新增加的部件
Q：数量变更
X：此部件包括在成套部件内，但该机型未采用。
Y：可选部件
Z：不可以单件提供的部件
 - (4) 部 件 名 称 (Part Name)

表示各部件特定的名称。
 - (5) 数 量 (Q'ty)

表示该机器1台所需要的数量。
 - (6) 适用机号范围 (Applicable Ser. No.)

适用机号范围，表示同行记载部件所适用的机器编号 (SER. No.) 范围。
另外，代替机器编号所记载的年月，是表示从此年月开始变更。

4. 关于各省略符号的说明

ass'y (assembly)	组合部件	o & p (overrun & parking brake)	自动减速、 停车用刹车
C/H (Change column)	变更	OPT. (Option)	选择
Comp. (Compressor)	压缩机	Press. (Pressure)	压力
Const. (Consisting of)	由...构成	SPC/S. (Special specifications)	特殊规范
Cont. (Control)	控制	STD. (Standards)	标准
Cyl. (Cylinder)	气缸体	T or t (Thickness)	厚度
Eng. (Engine)	引擎	w. (with)	带有...
EXP. (Export)	出口	w/o (without)	不带有...
Incl. (Including)	含有...		
L (Length)	长度		

5. 关于型式名称的说明

例: P D S □ 1 2 5 S □ - 5 B 1
 ① ② ③ ④ ⑤ ⑥ ⑦ ⑧ ⑨

- | | |
|--|---|
| <p>① PD: 移动式, 柴油机引擎
 SD: 固定式, 柴油机引擎
 SG: 固定式, 液化石油气引擎
 SM: 造雪机规范</p> <p>② R: 滑片式
 S: 螺杆式
 空白: 造雪机</p> <p>③ 空白: 0.69MPa 或 0.70MPa
 E: 0.86MPa
 F: 1.03MPa
 G: 1.18~1.37MPa
 H: 1.72MPa
 J: 2.07MPa
 K: 2.41~2.45MPa</p> <p>④ 125: 排气量 (cfm)</p> | <p>⑤ S: 低噪音型 (含有液化石油气引擎低噪音型)
 T: 都市石油气低噪音型
 空白: 非低噪音型</p> <p>⑥ C: 带后冷却器型
 D: 干燥气体型
 R: 列式喷射泵型
 W: 水冷规范型
 空白: 标准规范型</p> <p>⑦ 3: 支脚型
 4: 拖车型
 5: 箱型
 6: 宽体型
 空白: 其它</p> <p>⑧ 改型记号
 ⑨ 变更记号</p> |
|--|---|

※ 敝公司始终致力于产品的不断改良更新, 部件样本有未能记载全部变更的可能。敝公司根据需要对部件样本进行更新改版。若有不明之处, 请向最近的分店、或销售店咨询。

CONTENTS

目 录

FIG. NO. 图 号	FIG. NAME 图 名 称	PAGE 页
—COMPRESSOR PARTS—		
21 - 00	AIR END	压缩机本体 21- 1~4
31 - 00	MOUNTING, INTAKE, RECEIVER, SEPARATOR & SERVICE HEADER	底架、进气、储气、 分离与供气回路 31- 1~4
36 - 00	AIR LINE	空气回路 36- 1~3
37 - 00	OIL LINE & COOLING	油回路与冷却 37- 1~3
39 - 00	NAME PLATE	标牌 39- 1~4
41 - 00	ENGINE, EXHAUST & FUEL LINE	引擎、排气与燃料回路 41- 1~4
44 - 00	ELECTRIC	电气 44- 1~3
51 - 00	FRAME & BONNET	底盘与机壳 51- 1~3
52 - 00	LINING	防音材料 52- 1~3
54 - 00	RUNNING & STEERING	走行与转向 54- 1~3
ORDER MADE PARTS		
SS1- 00	WITHOUT TIRE TYPE (HIGHWAY TYPE)	无车轮型 (公路型) SS1-1
SS2- 00	WITHOUT TIRE TYPE	无车轮型 SS2-1
—ENGINE PARTS—		
	[WITHOUT PRE-FILTER]	[WITH PRE-FILTER]
Fig. 1.	CYLINDER BLOCK	CYLINDER BLOCK
Fig. 2.	GEAR HOUSING	GEAR HOUSING
Fig. 3.	MOUNTING FLANGE & OIL SUMP	MOUNTING FLANGE & OIL SUMP
Fig. 4.	CYLINDER HEAD & BONNET	CYLINDER HEAD & BONNET
Fig. 5.	SUCTION MANIFOLD	SUCTION MANIFOLD
Fig. 6.	EXHAUST MANIFOLD	EXHAUST MANIFOLD
Fig. 7.	CAMSHAFT & DRIVING GEAR	CAMSHAFT & DRIVING GEAR
Fig. 8.	CRANKSHAFT & PISTON	CRANKSHAFT & PISTON
Fig. 9.	LUB. OIL SYSTEM	LUB. OIL SYSTEM
Fig. 10.	COOLING WATER SYSTEM	COOLING WATER SYSTEM
Fig. 11.	FUEL INJECTION PUMP	FUEL INJECTION PUMP
Fig. 12.	GOVERNOR	GOVERNOR
Fig. 13.	FUEL INJECTION VALVE	FUEL INJECTION VALVE
Fig. 14.	FUEL LINE	FUEL LINE
Fig. 15.	STARTING MOTOR	STARTING MOTOR
Fig. 16.	GENERATOR	GENERATOR
Fig. 17.	GASKET SET	GASKET SET
Fig. 18.	(15A) STARTING MOTOR	—

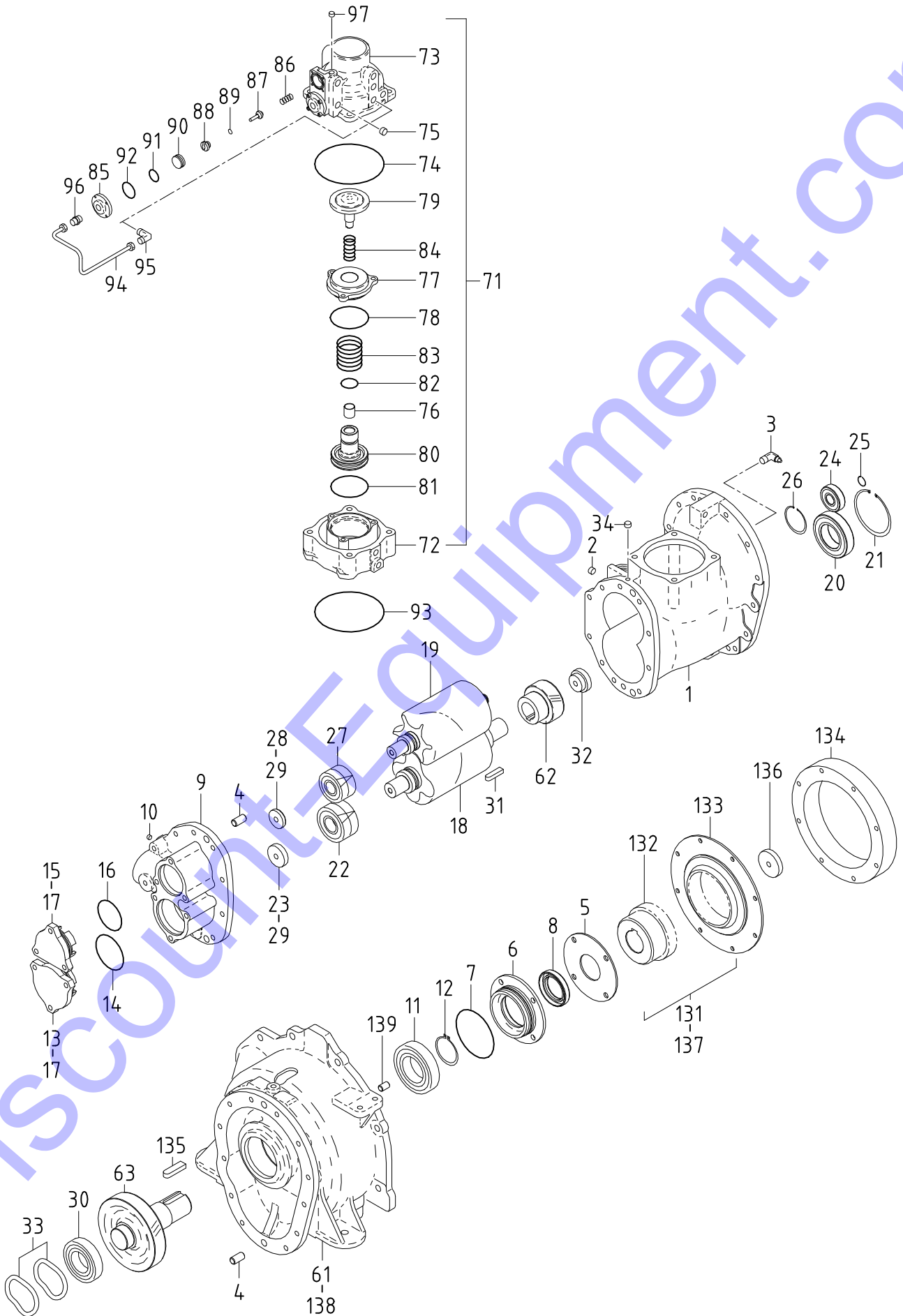

21 - 00 AIR END

Ref. NO. 索引编号	Part NO. 部件编号	Inter- change ability 互换性	Part Name 部件名称	Q'ty 数量	Applicable Ser. No. 适用机号 范围	Remarks 备考
21 - 00			COMPRESSION GROUP 压缩机构成			Const. No. 1~34
1	21201 41502		Cylinder, 1st 机体	1	~0051	
1 -1	21201 43900	B	Cylinder, 1st 机体	1	~3023	
1 -2	21201 45100	B	Cylinder, 1st 机体	1	3024~	
	02280 10030		Socket bolt 内六角螺栓	10		
	02280 10075		Socket bolt 内六角螺栓	2		
2	03620 60002		Plug 堵头	2	~3023	
2 -1	03620 60001	B	Plug 堵头	2	3024~	
3	03734 21010		Nipple elbow 螺纹弯接头	1		
4	03316 14028		Pin 销	4		
5	21212 18500		Cover, oil seal 盖, 油封	1		
	22153 03400		Bolt 螺栓	4		
6	21212 18300		Cover, oil seal 盖, 油封	1		
7	03402 10095		O-ring O型密封圈	1	~7167	
7 -1	03402 15095	A	O-ring O型密封圈	1	7168~	
8	21211 10800		Oil seal 油封	1		
9	21217 33300		Casing, discharge 排气侧缸体	1		
	02280 10030		Socket bolt 内六角螺栓	8		
	02280 10055		Socket bolt 内六角螺栓	2		
10	03620 60001		Plug 堵头	2		
11	03410 06211		Bearing 轴承	1		
12	03413 10055		Snap ring 扣环	1		
13	21218 33500		End cover 尾(端)盖	1		
14	22314 02500		O-ring O型密封圈	1	~7167	
14 -1	22314 02101	A	O-ring O型密封圈	1	7168~	
15	21218 33400		End cover 尾(端)盖	1		
16	22314 06200		O-ring O型密封圈	1	~7167	
16 -1	22314 02201	A	O-ring O型密封圈	1	7168~	
17	02280 08030		Socket bolt 内六角螺栓	6		
	03115 40008		Spring washer 弹簧垫圈	6		
18	21461 31600		Rotor, male 螺杆, 雄	1		
19	21462 22300		Rotor, female 螺杆, 雌	1		
A pair of rotor (male & female) should be ordered. 螺杆请成对订购。						
20	21406 29900		Bearing, rotor 轴承, 螺杆	1		
21	03413 20090		Snap ring 扣环	1		
22	21470 14300		Bearing, complete 轴承 (1组)	1		
23	21468 02700		Plate 板件	1		
24	21406 28700		Bearing, rotor 轴承, 螺杆	1		
25	03413 40020		Snap ring 扣环	1		
26	03413 20052		Snap ring 扣环	1		
27	21470 14400		Bearing, complete 轴承 (1组)	1		
28	21468 09200		Plate 板件	1		
29	02280 10030		Socket bolt 内六角螺栓	2		
	03115 30010		Lock washer 自锁垫圈	2		
30	03410 06209		Bearing 轴承	1		
31	03307 10040		Key 键	1		
32	21468 19800		Plate 板件	1		
	02280 10045		Socket bolt 内六角螺栓	1		
	03115 30010		Lock washer 自锁垫圈	1		
33	21222 09600		Washer 垫圈	2		
34	03620 60002	D	Plug 堵头	1	0052~	

21 - 00 AIR END

Ref. NO. 索引编号	Part NO. 部件编号	Inter- change ability 互换性	Part Name 部件名称	Q'ty 数量	Applicable Ser. No. 适用机号 范围	Remarks 备考
	21 - 01		COMPRESSION GROUP 压缩机构成			Const. No. 61~63
61	21214 18100		Casing, power side 引擎侧缸体	1		
62	21467 40900		Gear, driven 从动齿轮	1		
63	21469 31500		Gear, drive 主动齿轮	1		
	22 - 00		VALVE GROUP 阀构成			
71	22100 41201		Unloader ass'y 进气阀 (Const. No. 72~92, 94~97, See page 36-1 No. 35~37 & 46)	1	~3270	
71 -1	22100 42902	A	Unloader ass'y 进气阀 (Const. No. 72~92, 94~97, See page 36-1 No. 35~37, 46 & 47)	1	3271~	
	02280 10075		Socket bolt 内六角螺栓	4		
	03115 30010		Lock washer 自锁垫圈	4		
72	22111 28200		Body, unloader 机体, 进气阀	1		
73	22115 12701		Cover, unloader 盖, 进气阀	1		
74	03402 10125		O-ring O型密封圈	1		
75	03620 60002		Plug 堵头	1	~4515	
75 -1	03620 60002	Q	Plug 堵头	2	4516~	
76	23124 15600		Bushing 衬套	1		
77	22115 11300		Cover, unloader 盖, 进气阀	1		
	02282 08025		Socket bolt 内六角螺栓	3		
78	03402 10070		O-ring O型密封圈	1		
79	22150 13801		Valve 阀	1		
80	22130 09500		Piston, unloader 活塞, 进气阀	1		
81	21441 04800		O-ring O型密封圈	1		
82	21441 04900		O-ring O型密封圈	1		
83	22144 16700		Spring 弹簧	1		
84	22144 16600		Spring 弹簧	1		
85	36621 01401		Cover, auto relief 盖	2		
	02270 04012		Socket bolt, w/w 组合内六角螺栓	8		
86	22144 10600		Spring 弹簧	2		
87	36429 00801		Needle valve 针型阀	2	~3270	
87 -1	36429 01300	A	Needle valve 针型阀	2	~7167	
87 -2	36429 01600	A	Needle valve 针型阀	2	7168~	
88	36428 00700		Valve seat 阀密封	2	~7167	
88 -1	36428 01100	A	Valve seat 阀密封	2	7168~	
89	03402 25008		O-ring O型密封圈	2		
90	36623 00800		Piston, auto relief 活塞	2	~7167	
90 -1	36623 00900	A	Piston, auto relief 活塞	2	7168~	
91	03402 25021		O-ring O型密封圈	2		
92	21221 02100		O-ring O型密封圈	2		
93	03402 10125		O-ring O型密封圈	1		
94	36349 22400		Pipe 管	1	~0051	
94 -1	36349 22800	B	Pipe 管	1	0052~	
95	03734 53021		Nipple elbow 螺纹弯接头	1		
96	03734 52021		Nipple 管接头	1	~0051	
96 -1	03734 53021	B	Nipple elbow 螺纹弯接头	1	0052~	
97	03620 60002	C	Plug 堵头	1	4516~	

21 - 00 AIR END

Ref. NO. 索引编号	Part NO. 部件编号	Inter- change ability 互换性	Part Name 部件名称	Q' ty 数量	Applicable Ser. No. 适用机号 范围	Remarks 备考
	61 - 00		COUPLING GROUP			联轴器构成
131	21425 03800		Coupling, complete	1		联轴器组成
132	21412 07600		Gear, driven	1		从动齿轮
133	61111 13300		Gear, drive	1		主动齿轮
134	61122 05400		Fly wheel	1		飞轮
135	03307 14050		Key	1		键
136	21468 04400		Plate	1		板件
	02282 10030		Socket bolt	1		内六角螺栓
	03115 30010		Lock washer	1		自锁垫圈
137	02135 08060		Bolt	8		螺栓
	03115 02008		Spring washer	8		弹簧垫圈
138	02138 12030		Bolt	3		螺栓
	02138 12040		Bolt	5		螺栓
	03115 02012		Spring washer	8		弹簧垫圈
139	03316 08020		Pin	2		销

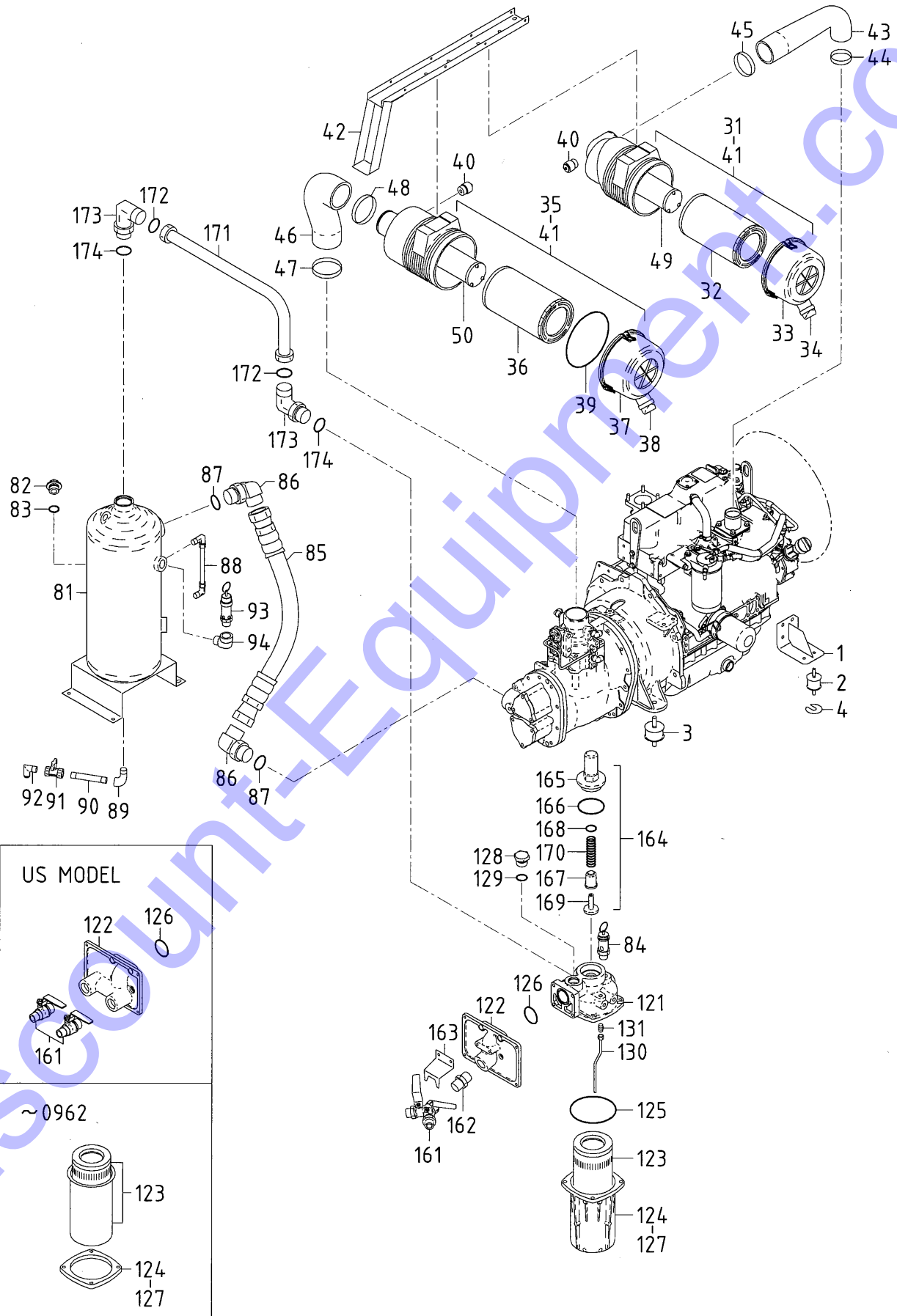

31 - 00 MOUNTING, INTAKE, RECEIVER, SEPARATOR & SERVICE HEADER

 Remarks
 A: EXP.
 B: US MODEL
 C: AUSTRALIA MODEL
 D: CHINA MODEL

Ref. NO. 索引编号	Part NO. 部件编号	Inter- change ability 互换性	Part Name 部件名称	Q' ty 数量	Applicable Ser. No. 适用机号 范围	Remarks 备考
31 - 00			MOUNTING GROUP	底架构成		
1	31110 06910		Bracket	2		
	02135 10020		Bolt	8		
	03115 02010		Spring washer	8		
2	31130 14200		Vibration isolator ass'y	2		
	02915 20008		Nut, w/w	4		
3	31130 20500		Vibration isolator ass'y	2		
	02915 20012		Nut, w/w	4		
4	31120 08900		Shim	2		
32 - 00			INTAKE GROUP	进气构成		
31	32100 40700		Air filter ass'y	1		Const. No. 32~34
32	32143 11700		Element	1		(outer)
33	32142 08600		Cup	1		
34	32151 01400		Vacuator valve	1		
35	32100 44900		Air filter ass'y	1		Const. No. 36~39
36	32143 11800		Element	1		(outer)
37	32142 11300		Cup	1		
38	32151 01600		Vacuator valve	1		
39	32147 03600		O-ring	1		
40	32148 00100		Filter service indicator	2		
41	02201 08012		Flange bolt	4		
42	32240 42501		Bracket	1		
	02201 08020		Flange bolt	4		
43	32331 78800		Hose	1		
44	03511 20070		Hose clip	1		
45	03511 20090		Hose clip	1		
46	32331 78700		Hose	1		
47	03511 20100		Hose clip	1		
48	03511 20110		Hose clip	1		
49	32143 12900		Element	1		(inner)
50	32143 13000		Element	1		(inner)
33 - 00			RECEIVER GROUP	储气构成		
81	33100 76110		Receiver tank	1		CLASS II JAP. REG.
81	33100 76110		Receiver tank	1	~4342	CLASS II JAP. REG. (AUS.)
81 -1	33100 84610	B	Receiver tank	1	4343~	CLASS II JAP. REG. (AUS.)
	02201 08020		Flange bolt	4		(AUS.)

31 - 00 MOUNTING, INTAKE, RECEIVER, SEPARATOR & SERVICE HEADER

 Remarks
 A: EXP.
 B: US MODEL
 C: AUSTRALIA MODEL
 D: CHINA MODEL

Ref. NO. 索引编号	Part NO. 部件编号	Inter- change ability 互换性	Part Name 部件名称	Q' ty 数量	Applicable Ser. No. 适用机号 范	Remarks 备考
						A B C D
81	33100 76610	C	Oil separator (Receiver tank)	1	5224~	SEMI ASME (KE) (SIN.)
81	33100 81710	C	Receiver tank	1	5355~	SEMI ASME (KE) (MAS.)
81	33100 78610		Receiver tank	1	~5223	SEMI ASME (EURE)
81 -1	33100 85810	A	Oil separator (Receiver tank) (Incl. No. 82)	1	5224~	SEMI ASME (EURE) (SIN.)
81	33100 78610		Receiver tank	1	~5354	SEMI ASME (EURE)
81 -1	33100 85810	A	Oil separator (Receiver tank) (Incl. No. 82)	1	5355~	SEMI ASME (EURE) (MAS.)
81	33100 76010		Receiver tank (Incl. No. 82, 83)	1		ASME
81	33100 76710		Receiver tank	1		GB
	02201 08020		Flange bolt	4		
82	33231 02500		Cap, oil filler	1		CLASS II JAP. REG. / SEMI ASME (KE) / GB
82	33231 04000		Cap, oil filler	1		SEMI ASME (EURE)
82	33231 03600		Cap, oil filler	1		ASME
83	03402 25030		O-ring	1		
84	35200 15200		Safety valve ass'y	1		◎ ◎
84	03620 41006		Plug	1		◎
84	35200 19500		Safety valve ass'y	1	~5634	◎
84 -1	35200 21400	A	Safety valve ass'y	1	5635~	◎
85	37160 47910		Pipe	1		(Hose)
86	03734 85140		Nipple elbow	2		Incl. No. 87
87	03402 25044		O-ring	2		
88	03841 30015		Nylon tube, w/n	1		
	03734 21030		Nipple elbow	2		
89	03731 21004		Elbow	1		
90	03730 04110		Gas pipe	1		
91	03735 13004		Valve	1		
92	37730 02001		Nipple	1		
93	35200 14100		Safety valve ass'y	1		- ◎ - -
94	37740 01400		Elbow	1		- ◎ - -
94	03620 41006		Plug	1		◎ [SEMI ASME (EURE)]

34 - 00 SEPARATOR GROUP 油分离构成

121	34210 32600		Casing	1	~0962	
121 -1	34210 32900	B	Casing	1	0963~	
122	35108 07300		Flange	1	~0962	◎ ◎ ◎
122 -1	35108 07500	B	Flange	1	0963~	◎ ◎ ◎
	02201 10020		Flange bolt	4		◎ ◎ ◎
122	35100 53100		Air manifold	1	~0962	◎
122 -1	35100 53901	B	Air manifold	1	0963~	◎
	02201 08020		Flange bolt	4		◎
	02283 10035	C	Socket bolt	4	0963~	
	02283 10045	D	Socket bolt	4	0963~	
	03115 31010		Lock washer	4		
123	34220 16101		Separator	1	~0962	
123 -1	34224 03000	B	Element	1	0963~	
124	34250 18301		Cover, separator	1	~0962	
124 -1	34250 30501	B	Cover, separator	1	0963~	

31 - 00 MOUNTING, INTAKE, RECEIVER, SEPARATOR & SERVICE HEADER

Remarks
 A: EXP.
 B: US MODEL
 C: AUSTRALIA MODEL
 D: CHINA MODEL

Ref. NO. 索引编号	Part NO. 部件编号	Inter-changeability 互换性	Part Name 部件名称		Q' ty 数量	Applicable Ser. No. 适用机号范围	Remarks 备考
125	03402 15140		O-ring	O型密封圈	1	~0962	
125 -1	03402 15145	B	O-ring	O型密封圈	1	0963~	
126	03402 15050		O-ring	O型密封圈	1		
127	02283 10035		Socket bolt	内六角螺栓	4	~0962	
127 -1	02283 10030	B	Socket bolt	内六角螺栓	4	0963~	
	03115 30010		Lock washer	自锁垫圈	4		
128	33238 01600		Plug	堵头	1	~0962	Incl. No. 129
128 -1	33238 01600	Q	Plug	堵头	2	0963~	Incl. No. 129
129	03402 25029		O-ring	O型密封圈	1	~0962	
129 -1	03402 25029	Q	O-ring	O型密封圈	2	0963~	
130	34260 07000		Pipe	管	1		
131	03734 70021		Nipple	管接头	1		

35 - 00 SERVICE HEADER GROUP 供气回路构成

161	35421 07700		Air valve	空气阀	1		◎ ◎ ◎
161	35421 00105		Air valve	空气阀	2		◎
162	03731 42008		Nipple	管接头	1		◎ - ◎ ◎
163	35470 41200		Bracket	支架(板)	1		◎ - ◎ ◎
	02201 08020		Flange bolt	法兰螺栓	2		◎ - ◎ ◎
164	35300 17000		Press. cont. vlv. ass'y	压力控制阀	1		Const. No. 165~170
165	35301 20200		Body	阀体	1		
166	03402 15075		O-ring	O型密封圈	1		
167	35303 08400		Piston	活塞	1		
168	03402 25032		O-ring	O型密封圈	1		
169	35303 03300		Piston	活塞	1		
170	22144 07700		Spring	弹簧	1		
171	33410 03600		Pipe	管	1	~0962	
171 -1	33410 03800	B	Pipe	管	1	0963~	
172	37187 01200		O-ring	O型密封圈	2		
173	GD920 14300		Nipple	管接头	2		Incl. No. 174
174	03402 25038		O-ring	O型密封圈	2		

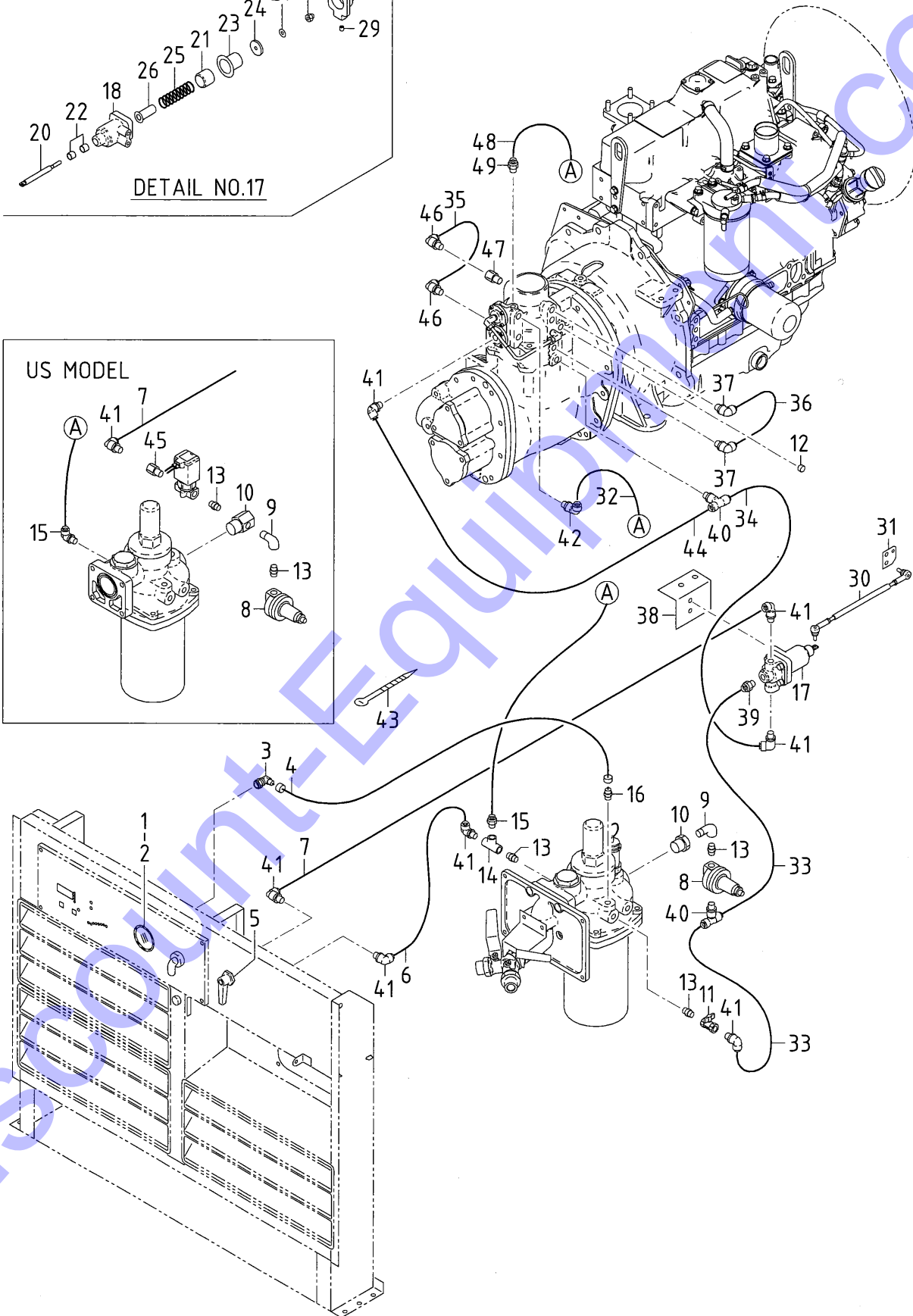
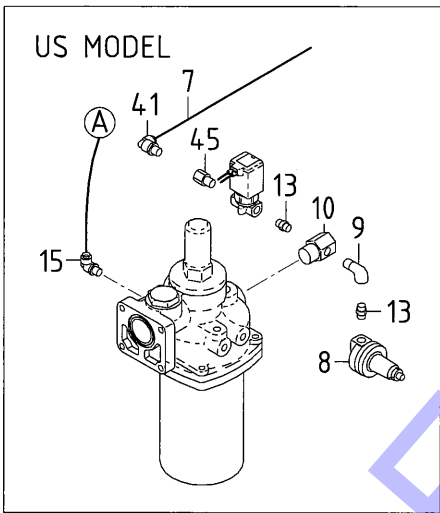
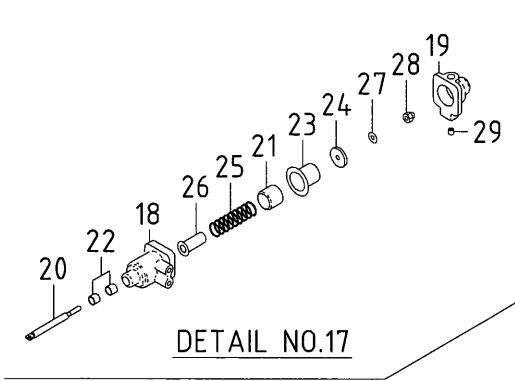

36 - 00 AIR LINE

 Remarks
 A: EXP.
 B: US MODEL
 C: AUSTRALIA MODEL
 D: CHINA MODEL

Ref. NO. 索引编号	Part NO. 部件编号	Inter- change ability 互换性	Part Name 部件名称	Q'ty 数量	Applicable Ser. No. 适用机号 范围	Remarks 备考
	36 - 00		CONTROL GROUP			A B C D
1	36141 15503		Gauge, air press.	1		◎ ◎
1	36141 18600		Gauge, air press.	1		◎ ◎
2	36131 03100		Cushion rubber	1		
3	36152 02500		Bushing	1		◎ ◎
3	03734 21151		Nipple elbow	1		◎ ◎
4	03840 15060		Nylon tube, w/n	1		
	06540 07060		Corrugated tube	1		
5	35421 01600		Air valve	1		◎ - ◎ ◎
6	03890 20035		Nylon tube	1		◎ - ◎ ◎
7	03890 20077		Nylon tube	1		◎ - ◎ ◎
7	03890 20024		Nylon tube	1		◎
8	36400 19000		Regulator ass'y	1		(PRESS. CONTROL)
9	03731 21002		Elbow	1		
10	03732 00602		Bush	1		◎ ◎ ◎
10	37189 37000		Bushing	1		◎
11	03735 13002		Valve	1		
12	03620 60002		Plug	4		◎ ◎ ◎
12	03620 60002		Plug	2		◎
13	03731 44002		Nipple	3		
14	03731 30002		Tee	1		◎ - ◎ ◎
15	03734 64028		Nipple	1		◎ ◎ ◎
15	03734 65028		Nipple elbow	1		◎
16	03734 20015		Nipple	1	~0962	
16 -1	03734 21015	A	Nipple elbow	1	0963~	
17	36400 21901		Regulator ass'y	1	~3270	Const. No. 18~29
17 -1	36400 23200	A	Regulator ass'y	1	~5845	Const. No. 18~29
17 -2	36400 23800	A	Regulator ass'y	1	5846~	Const. No. 18~29
	02238 08020		Bolt, w/w	2		
18	36421 03600		Body	1		
19	36422 01900		Cap	1		
	02283 06025		Socket bolt	4		
	03115 40006		Spring washer	4		
20	22152 04900		Shaft	1		
21	22130 05500		Piston	1		
22	23124 10300		Bushing	2		
23	36437 01500		Diaphragm	1		
24	36435 01400		Washer	1		
25	22144 12800		Spring	1		
26	31144 14400		Spacer	1	~3270	
26 -1	31144 14500	B	Spacer	1	~5845	
26 -2	31144 16000	B	Spacer	1	5846~	
27	34232 00300		Gasket	1		
28	02914 60008		Locking nut	1		
29	22123 04400		Orifice	1	~3270	
29 -1	22123 05100	B	Orifice	1	3271~	
30	36280 33301		Rod	1		
	02915 20006		Nut, w/w	2		
	03116 12006	C	Plain washer	2	4961~	
	52744 03100	D	Washer	1	4961~	

36 - 00 AIR LINE

Remarks
 A: EXP.
 B: US MODEL
 C: AUSTRALIA MODEL
 D: CHINA MODEL

Ref. NO. 索引编号	Part NO. 部件编号	Inter- change ability 互换性	Part Name 部件名称	Q' ty 数量	Applicable Ser. No. 适用机号 范围	Remarks 备考
						A B C D
31	36221 04500		Lever	1		
	02201 08020	C	Flange bolt	2	1474~	
	02238 08020	D	Bolt, w/w	2	1474~	
	02138 08016	B	Bolt	2	4961~	
	02915 20008		Hexagon flange nut	2		
32	03890 30046	C	Nylon tube	1	4516~	
33	03890 20030		Nylon tube	2		
34	03890 20025		Nylon tube	1		
35	03890 20030		Nylon tube	1	~0051	
35 -1	03890 20020	B	Nylon tube	1	~3270	
35 -2	03890 25027	B	Nylon tube	1	3271~	
36	03890 20020		Nylon tube	1		
37	03734 65020		Nipple elbow	2		
38	36711 23500		Plate	1		
	02248 10020		Bolt, w/w	1		
39	03734 64020		Nipple	1		
40	03734 66020		Tee nipple	2		
41	03734 65020		Nipple elbow	7		◎ ◎ ◎
41	03734 65020		Nipple elbow	5		◎
42	03734 65028	C	Nipple elbow	1	4516~	
43	03425 00001		Vinyl clip	5		
44	03890 20020		Nylon tube	1		
45	37189 03300		Bushing	1		- ◎ - -
46	03734 65020		Nipple elbow	2	~3270	
46 -1	03734 65024	A	Nipple elbow	2	3271~	
47	37189 19700	D	Bushing	1	3271~	
48	03890 30046	D	Nylon tube	1	4516~	
49	03734 64028	D	Nipple	1	4516~	

37 - 00 OIL LINE & COOLING

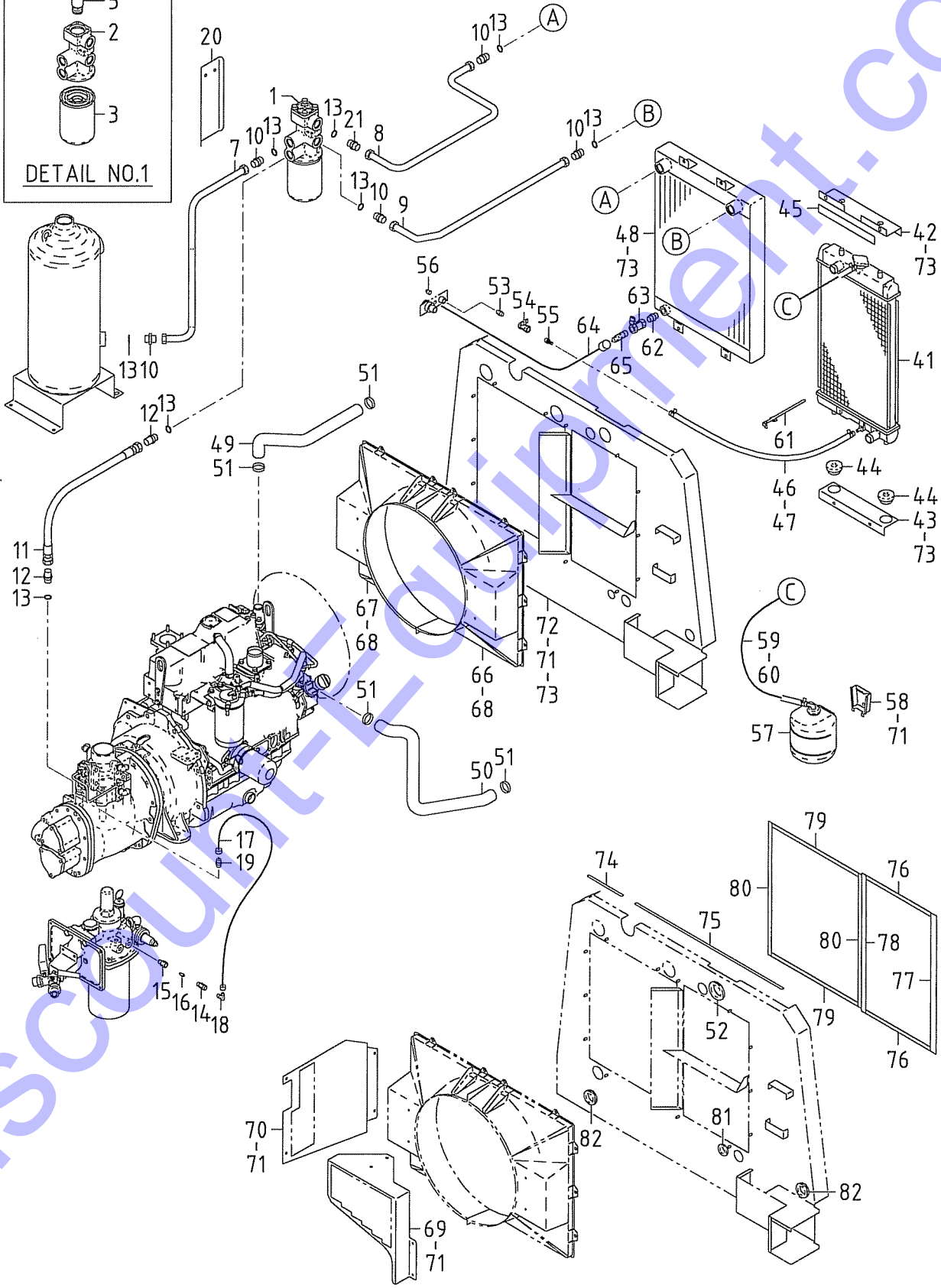
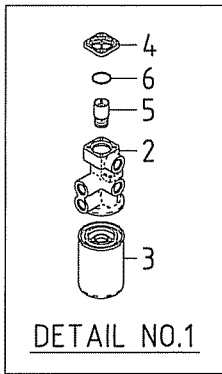

37 - 00 OIL LINE & COOLING

Ref. NO. 索引编号	Part NO. 部件编号	Inter- change ability 互换性	Part Name 部件名称	Q'ty 数量	Applicable Ser. No. 适用机号 范围	Remarks 备考
37 - 00 OIL LINE GROUP 油回路构成						
1	37400 16100		Oil filter ass'y	1	~0892	Const. No. 2~6
1 -1	37400 16200	B	Oil filter ass'y	1	0893~	Const. No. 2~6
	02201 10020		Flange bolt	2		
2	37411 07600		Body	1	~0892	
2 -1	37411 07801	B	Body	1	0893~	
3	37438 08900		Filter cartridge	1		
4	37215 02800		Cover	1		
	02138 08030		Bolt	4		
	03115 02008		Spring washer	4		
	03116 12008		Plain washer	4		
5	37231 02100		Pellet ass'y	1		
6	03402 25045		O-ring	1		
7	37111 22302		Pipe	1	~0892	
7 -1	37111 23100	B	Pipe	1	0893~	
8	37112 49000		Pipe	1	~0892	
8 -1	37112 49700	B	Pipe	1	0893~	
9	37114 25000		Pipe	1	~0892	
9 -1	37114 26000	B	Pipe	1	0893~	
10	03734 75060		Nipple	5		Incl. No. 13
11	37110 04600		Hose	1	~4599	
11 -1	37110 08300	A	Hose	1	4600~	
12	GD920 14700		Nipple	2		Incl. No. 13
13	03402 25024		O-ring	8		
14	22200 16100		Check valve ass'y	1		
15	37189 34400		Bushing	1		
16	37580 01900		Strainer	1		
17	03841 20087		Nylon tube, w/n	1		
	06540 07085		Corrugated tube	1		
18	03734 21020		Nipple elbow	1		
19	03734 20201		Nipple	1		
20	37510 37400		Bracket	1	~0892	
	02201 08020		Flange bolt	2	~0892	
20 -1	37510 38100	B	Bracket	1	0893~	
	02201 06016	B	Flange bolt	2	0893~	
21	03734 75060		Nipple	1	~0892	Incl. No. 13
21 -1	03734 76060	B	Nipple	1	0893~	Incl. No. 13
38 - 00 COOLING GROUP 冷却构成						
41	38100 43600		Radiator	1		
	38410 05700		Cap	1		
42	38420 95400		Bracket	1		
43	38420 96000		Bracket	1		
44	31131 04900		Rubber	2		
45	03407 64632		Seal rubber	1		
46	03611 08075		Hose	1		
47	03511 40018		Hose clip	2		
48	38200 32500		Oil cooler	1		
49	38524 70500		Hose (upper)	1		

37 - 00 OIL LINE & COOLING

Ref. NO. 索引编号	Part NO. 部件编号	Inter- change ability 互换性	Part Name 部件名称	Q' ty 数量	Applicable Ser. No. 适用机号 范围	Remarks 备考
50	38524 70600		Hose(lower)	软管(下)	1	
51	03511 20040		Hose clip	软管锁扣	4	
52	03403 00512		Grommet	环形圈	1	
53	03731 42002		Nipple	管接头	1	
54	03735 13002		Valve	阀	1	
55	37170 14000		Joint	接头	1	
56	03620 41002		Plug	堵头	1	
57	38590 01400		Reserve tank ass'y	辅助罐	1	
58	38591 00400		Bracket	支架(板)	1	
59	38594 04900		Hose	软管	1	
60	03511 40016		Hose clip	软管锁扣	2	
61	37181 03600		Clip	锁扣	4	
62	03731 42003		Nipple	管接头	1	
63	03735 13003		Valve	阀	1	
64	03851 30032		Nylon tube, w/n	带螺母尼龙软管	1	
65	03734 21030		Nipple elbow	螺纹弯接头	1	
66	38440 08410		Shroud, fan	风扇罩	1	
67	38440 08510		Shroud, fan	风扇罩	1	
68	02915 00006		Hexagon flange nut	法兰螺母	14	
69	38450 86100		Guard, fan	风扇保护罩	1	
70	38450 86000		Guard, fan	风扇保护罩	1	~0892
70 -1	38450 87700	B	Guard, fan	风扇保护罩	1	0893~
71	02201 06016		Flange bolt	法兰螺栓	13	
72	52350 70022		Cover	盖	1	
73	02201 08020		Flange bolt	法兰螺栓	11	
74	03407 68012		Seal rubber	密封橡胶	1	
75	03407 68060		Seal rubber	密封橡胶	1	
76	03407 66923		Seal rubber	密封橡胶	2	
77	03407 44053		Seal rubber	密封橡胶	1	
78	03407 67304		Seal rubber	密封橡胶	1	
79	03407 66819		Seal rubber	密封橡胶	2	
80	03407 66842		Seal rubber	密封橡胶	2	
81	03403 00303		Grommet	环形圈	1	
82	03403 00392		Grommet	环形圈	1	~0752
82 -1	03403 00392	Q	Grommet	环形圈	2	0753~

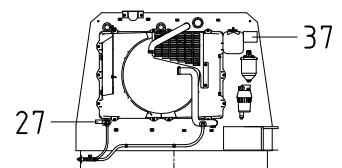
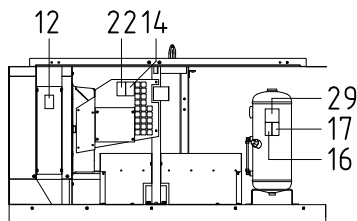
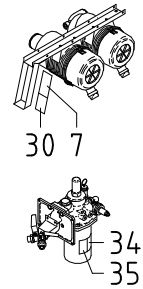
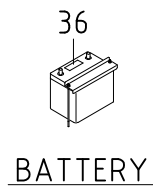
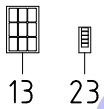
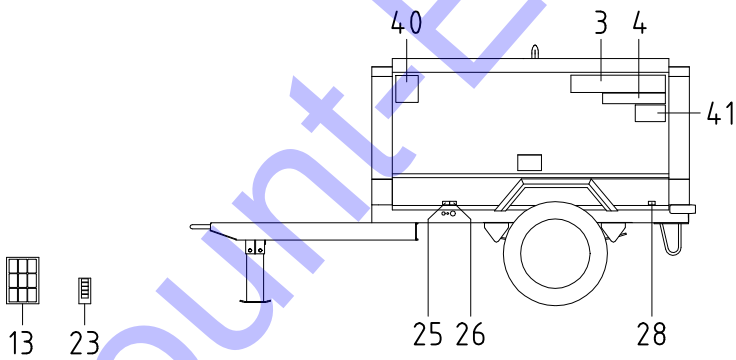
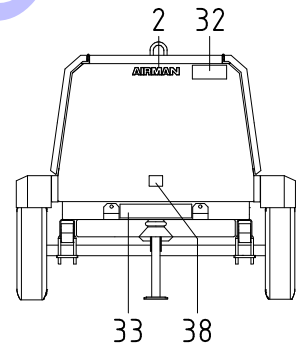
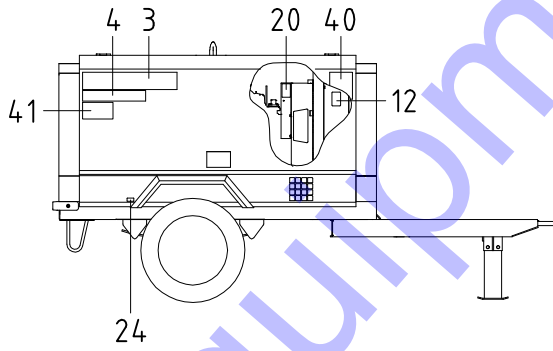
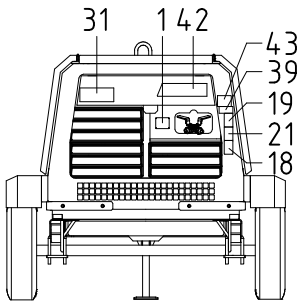
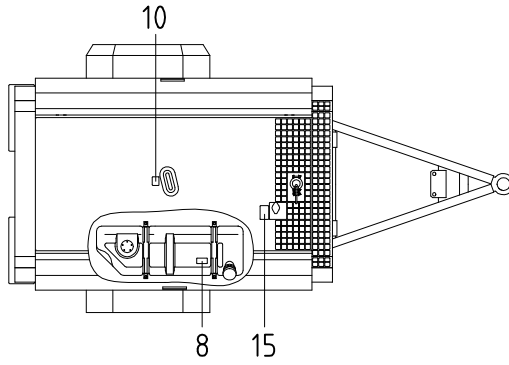
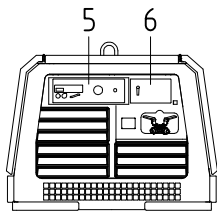

FAN SHROUD

39 - 00 NAME PLATE

 Remarks
 A: EXP.
 B: US MODEL
 C: AUSTRALIA MODEL
 D: CHINA MODEL

Ref. NO. 索引编号	Part NO. 部件编号	Inter- change ability 互换性	Part Name 部件名称	Q'ty 数量	Applicable Ser. No. 适用机号 范围	Remarks 备考
	39 - 00		ACCESSORY GROUP			A B C D
	39600 14732		Instruction manual	1		⊙
	39600 15131		Instruction manual	1		⊙
	39600 15332		Instruction manual	1		⊙
	39600 15032		Instruction manual	1		⊙
	39615 07700		Instruction manual (Eng.)	1		⊙
1	39103 10811		Plate (SER. NO.)	1		
	03260 03010		Blind rivet	4		
2	39170 02000		Mark (AIRMAN)	1		
3	39178 23930		Plate (AIRMAN)	2		
4	39178 24030		Plate (PDS185S)	2		
5	39178 64130		Plate (in-pane)	1		⊙ ⊙
5	39178 64630		Plate (in-pane)	1		⊙
5	39178 64530		Plate (in-pane)	1		⊙
6	39153 67300		Plate (start-stop)	1		⊙ ⊙
6	39153 67500		Plate (start-stop)	1		⊙
6	39153 67400		Plate (start-stop)	1		⊙
7	39176 04810		Plate (notice)	1		⊙ ⊙ ⊙
7	39176 05210		Plate (notice)	1		⊙
8	39178 99730		Plate (diesel fuel)	1		⊙ ⊙
8	39178 22030		Plate (diesel fuel)	1		⊙
8	39178 01340		Plate (diesel fuel)	1		⊙
9	* * *					
10	39176 69300		Plate (lift position)	1		⊙ ⊙ ⊙
10	39176 78500		Plate (lift position)	1		⊙
11	* * *					
12	39176 69500		Plate (caution, high temp.)	2		⊙ ⊙ ⊙
12	39176 79200		Plate (caution, high temp.)	2		⊙
13	39173 04200		Plate, complete (Const. No. 14~22)	1		⊙ ⊙ ⊙ -
14	39176 69500	Z	Plate (caution, high temp.)	1		⊙ ⊙ ⊙
14	39176 79200		Plate (caution, high temp.)	1		⊙
15	39176 69600	Z	Plate (caution, radiator cap)	1		⊙ ⊙ ⊙
15	39176 79300		Plate (caution, radiator cap)	1		⊙
16	39176 69700	Z	Plate (caution, fire)	1		⊙ ⊙ ⊙
16	39176 79400		Plate (caution, fire)	1		⊙
17	39176 69800	Z	Plate (warning, compressed air)	1		⊙ ⊙ ⊙
17	39176 79500		Plate (caution, compressed air)	1		⊙
18	39176 73300	Z	Plate (warning, exhaust gases)	1		⊙ ⊙ ⊙
18	39176 78700		Plate (caution, exhaust gases)	1		⊙

39 - 00 NAME PLATE

Remarks
 A: EXP.
 B: US MODEL
 C: AUSTRALIA MODEL
 D: CHINA MODEL

Ref. NO. 索引编号	Part NO. 部件编号	Inter-change ability 互换性	Part Name 部件名称	Q'ty 数量	Applicable Ser. No. 适用机号范围	Remarks 备考
						A B C D
19	39176 73400	Z	Plate (warning, compressed air)	1		⊙ ⊙ ⊙
19	39176 78800		Plate (caution, compressed air)	1		⊙
20	39176 73500	Z	Plate (warning, cooling fan)	1		⊙ ⊙ ⊙
20	39176 78900		Plate (caution, rotation)	1		⊙
21	39176 73600	Z	Plate (danger, compressed air)	1		⊙ ⊙ ⊙
21	39176 79000		Plate (warning, compressed air)	1		⊙
22	39176 73800	Z	Plate (warning, V-belt)	1		⊙ ⊙ ⊙
22	39176 78900		Plate (caution, rotation)	1		⊙
23	39173 02100		Plate, complete (Const. No. 24~28)	1		⊙ ⊙ ⊙ -
24	39189 17100	Z	Plate (fuel drain)	1		⊙ ⊙ ⊙
24	39189 17600		Plate (fuel drain)	1		⊙
25	39189 17200	Z	Plate (radiator drain)	1		⊙ ⊙ ⊙
25	39189 17700		Plate (radiator drain)	1		⊙
26	39189 17300	Z	Plate (eng. oil drain)	1		⊙ ⊙ ⊙
26	39189 17800		Plate (eng. oil drain)	1		⊙
27	39189 17400	Z	Plate (oil cooler drain)	1		⊙ ⊙ ⊙
27	39189 17900		Plate (oil cooler drain)	1		⊙
28	39189 19100	Z	Plate (receiver oil drain)	2		⊙ ⊙ ⊙ (spare:1)
28	39189 18000		Plate (receiver tank drain)	1		⊙
29	39147 00602		Plate (comp. oil)	1		⊙ ⊙
29	39147 02800		Plate (comp. oil)	1		⊙
29	39179 02201		Plate (genuine oil)	1		⊙
30	39176 05110		Plate (strainer)	1		⊙ ⊙ ⊙
30	39176 05310		Plate (strainer)	1		⊙
31	39178 63100		Plate (speed limit)	1		⊙ - - ⊙
32	39178 63200		Plate (never exceed)	1		⊙ - - ⊙
33	39176 04910		Plate (caution, draw bar)	1		⊙
33	39176 05410		Plate (caution, draw bar)	1		⊙
34	39176 59300	C	Plate (separator)	1	0963~	- - - ⊙
35	39176 79500	C	Plate (caution, compressed air)	1	0963~	- - - ⊙
36	39176 50000		Plate (danger, battery)	1		
37	39178 25210		Plate (LLC)	1		⊙ ⊙
37	39178 00310		Plate (LLC)	1		⊙
37	39178 16320		Plate (LLC)	1		⊙

39 - 00 NAME PLATE

Remarks
 A: EXP.
 B: US MODEL
 C: AUSTRALIA MODEL
 D: CHINA MODEL

Ref. NO. 索引编号	Part NO. 部件编号	Inter- change ability 互换性	Part Name 部件名称	Q' ty 数量	Applicable Ser. No. 适用机号 范围	Remarks 备考
38	39178 37310		Plate (caution, tow machine)	1		A B C D - ◎ ◎ -
39	39178 43110		Plate (california)	1		- ◎ - -
40	39178 13330		Plate (mark)	2		- ◎ - -
41	39178 12630		Plate (mark)	2		- ◎ - -
42	39178 72410		Plate (mark)	1	~7518	- ◎ - -
42 -1	39178 45140	B	Plate (Made in JAPAN)	1	7519~	◎ - ◎ -
43	39176 09710	D	Plate (caution, restart)	1	4367~	◎ - ◎ -

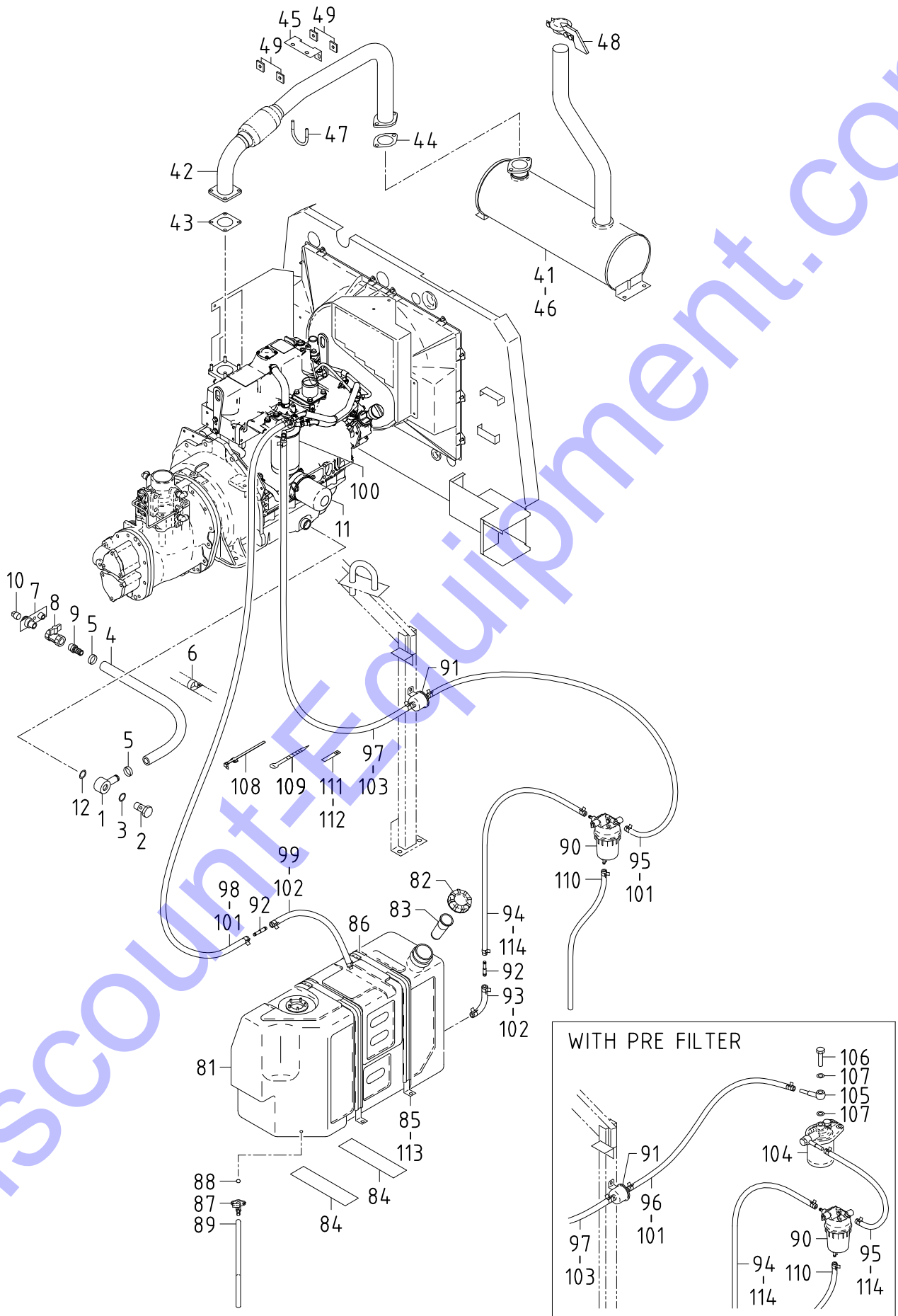

41 - 00 ENGINE, EXHAUST & FUEL LINE

 Remarks
 A: EXP.
 B: US MODEL
 C: AUSTRALIA MODEL
 D: CHINA MODEL

Ref. NO. 索引编号	Part NO. 部件编号	Inter- change ability 互换性	Part Name 部件名称	Q'ty 数量	Applicable Ser. No. 适用机号 范围	Remarks 备考
41 - 00			ENGINE GROUP	引擎构成		
1	43534 01702		Ring connector (Nipple)	1		
2	43532 05201		Nipple (Bolt)	1		
3	03407 16022		Gasket	1		
4	03580 19070		Hose	1		
5	03511 20035		Hose clip	2		
6	03424 80039		Clip	1		
	02201 08020		Flange bolt	1		
7	41250 05600		Bracket	1		
	02201 06016		Flange bolt	2		
8	03735 13004		Valve	1		
9	37170 02900		Joint	1		
10	03620 41004		Plug	1		
11	41290 01100		Filter ass'y, Eng. oil	1	~4151	◎ ◎ ◎ ◎ See Engine parts Fig. 9.
11 -1	41290 01200	B	Filter ass'y, Eng. oil	1	~5935	- - ◎ -
11 -2	41290 01100	B	Filter ass'y, Eng. oil	1	5936~	- - ◎ - See Engine parts Fig. 9.
12	03407 16022		Gasket	1	~1179	
12 -1	41330 00700	B	Gasket	1	1180~	
42 - 00			EXHAUST GROUP	排气构成		
41	42100 81400		Exhaust muffler	1		
42	42310 96901		Pipe, exhaust	1		
	02136 10035		Bolt	2		(for muffler)
	02912 06010		Nut	2		(for muffler)
	03115 06010		Spring washer	2		(for muffler)
	03116 15010		Plain washer	2		(for muffler)
	02915 01008		Hexagon flange nut	4		(for Eng.)
43	42324 14900		Gasket	1		
44	42324 13600		Gasket	1		
45	42240 30202		Bracket	1		
	02201 08020	C	Flange bolt	2	0103~	
	02201 08030	D	Flange bolt	2	0103~	
	02201 08030	C	Flange bolt	2	0753~	
	02201 08020	D	Flange bolt	2	0753~	
46	02201 08020		Flange bolt	2		
47	03830 08004		U-bolt	1		
	02915 00008		Hexagon flange nut	2		
48	42210 02700		Cap, muffler	1		OPT.
49	31130 27000	D	Vibration isolator ass'y	4	0103~	
	45214 02200	D	Washer	2	0103~	
	52162 00300	D	Collar	2	0103~	
49 -1	31130 27000	C	Vibration isolator ass'y	4	0753~	
	45214 02200	C	Washer	2	0753~	
	52162 00300	C	Collar	2	0753~	

41 - 00 ENGINE, EXHAUST & FUEL LINE

 Remarks
 A: EXP.
 B: US MODEL
 C: AUSTRALIA MODEL
 D: CHINA MODEL

Ref. NO. 索引编号	Part NO. 部件编号	Inter- change ability 互换性	Part Name 部件名称	Q'ty 数量	Applicable Ser. No. 适用机号 范围	Remarks 备考
A B C D						
43 - 00 FUEL GROUP 燃料构成						
81	43100 43802		Fuel tank	1	~0540	
81 -1	43100 75500	B	Fuel tank	1	0541~	
82	43220 02200		Cap	1	~0540	
82 -1	43220 03000	B	Cap	1	0541~	
83	43210 01700		Strainer	1		
84	38465 11901		Cushion rubber	2		
85	43310 31300		Belt	2	~0241	
85 -1	43310 31700	A	Belt	2	0242~	
86	43322 06200		Cushion	4	~0241	
86 -1	43322 06200	Q	Cushion	2	0242~	
87	35421 05500		Air valve	1		
	02248 06012		Bolt, w/w	2		
88	03402 25014		O-ring	1		
89	03600 08020		Hose	1		
90	43550 02900		Sedimenter	1	~5388	(YANMAR 129242-55701)
90 -1	43550 03200	B	Sedimenter	1	5389~	(YANMAR 129268-55701)
	02201 08070		Flange bolt	1		See Engine parts Fig. 14.
91	43650 02700		Fuel pump	1		
	02201 06016		Flange bolt	2		
92	43525 01800		Pipe, connection	2		
93	03600 09012		Hose	1		
94	03600 08031		Hose	1	~5388	
94 -1	03600 08021	B	Hose	1	~7403	
94 -2	43510 11400	A	Hose	1	7404~	
95	03600 08105		Hose	1		w/o PRE-FILTER
95	03600 08037		Hose	1	~7403	w. PRE-FILTER
95 -1	43510 11700	A	Hose	1	7404~	w. PRE-FILTER
96	03600 08076		Hose	1		w. PRE-FILTER
97	03600 08050		Hose	1		
98	03600 08080		Hose	1		
99	03600 09012		Hose	1		
100	43543 01400		Filter, cartridge	1	~4151	◎ ◎ ◎ ◎ See Engine parts Fig. 14.
100 -1	43543 01800	B	Filter, cartridge	1	~5935	- - ◎ -
100 -2	43543 01400	B	Filter, cartridge	1	5936~	- - ◎ - See Engine parts Fig. 14.
101	03511 40016		Hose clip	4		w/o PRE-FILTER
101	03511 40016		Hose clip	4		w. PRE-FILTER
102	03511 40020		Hose clip	4		
103	03511 10017		Hose clip	2		
104	43540 08100		Filter ass'y	1		w. PRE-FILTER
	43541 02400		Element	1		See Engine parts Fig. 14.
	02201 08030		Flange bolt	2		w. PRE-FILTER
105	43534 05000		Ring connector	2		w. PRE-FILTER
106	43532 09200		Nipple	2		w. PRE-FILTER
107	43531 02000		Gasket	4		w. PRE-FILTER
108	37181 03600		Clip	1		
109	03425 00001		Vinyl clip	5		

41 - 00 ENGINE, EXHAUST & FUEL LINE

Remarks
 A: EXP.
 B: US MODEL
 C: AUSTRALIA MODEL
 D: CHINA MODEL

Ref. NO. 索引编号	Part NO. 部件编号	Inter- change ability 互换性	Part Name 部件名称		Q' ty 数量	Applicable Ser. No. 适用机号 范围	Remarks 备考
110	03600 06050		Hose	软管	1		
	03511 40006		Hose clip	软管锁扣	1		
111	03424 80101		Clip	锁扣	1		w/o PRE-FILTER
112	02201 08020		Flange bolt	法兰螺栓	1		w/o PRE-FILTER
113	02201 08020		Flange bolt	法兰螺栓	4	~0241	
113 -1	02201 08030	A	Flange bolt	法兰螺栓	4	0242~	
114	03511 10013		Hose clip	软管锁扣	2	~7403	w/o PRE-FILTER
114 -1	03511 40020	A	Hose clip	软管锁扣	2	7404~	w/o PRE-FILTER
114	03511 10013		Hose clip	软管锁扣	4	~7403	w. PRE-FILTER
114 -1	03511 40020	A	Hose clip	软管锁扣	4	7404~	w. PRE-FILTER

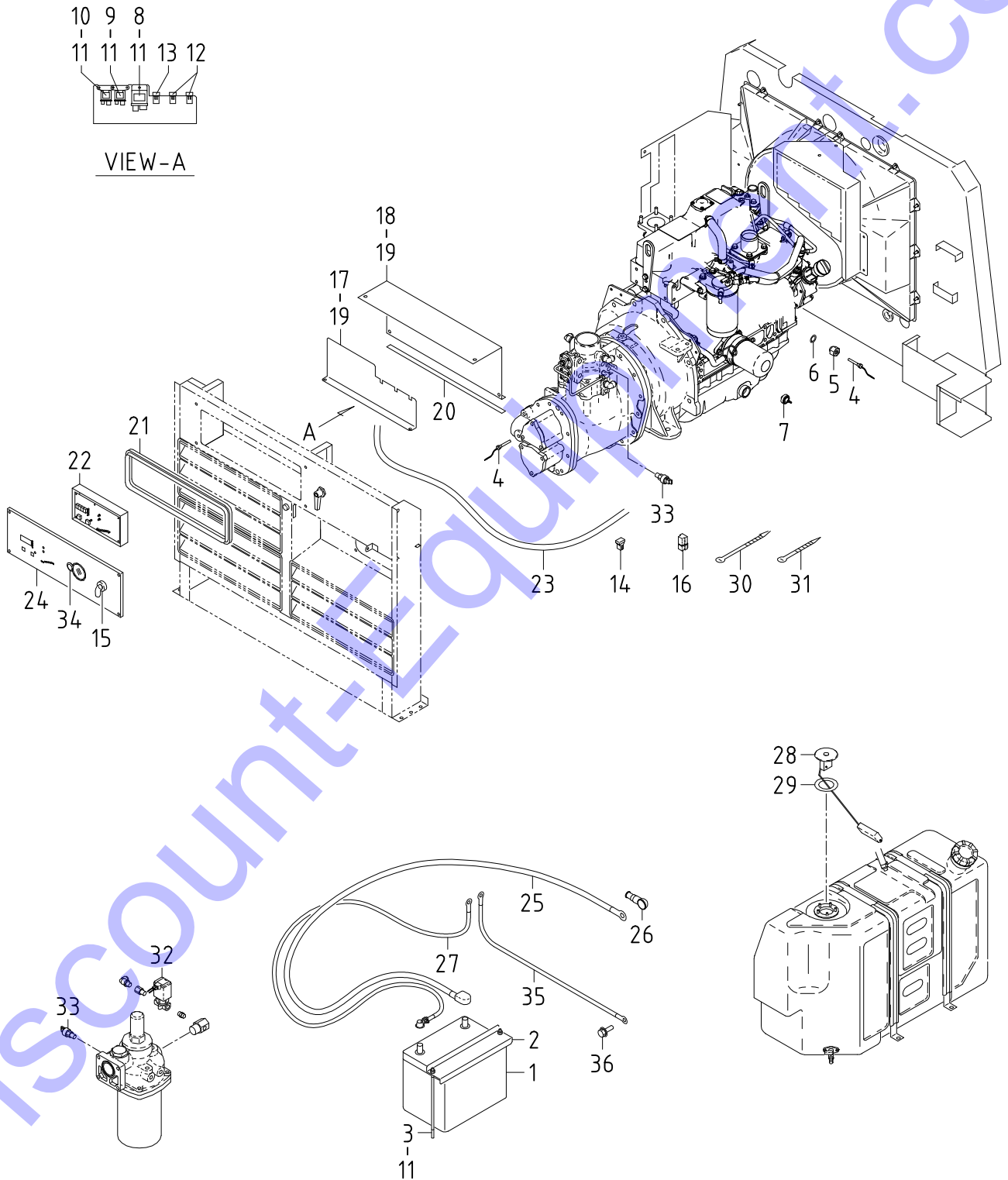

44 - 00 ELECTRIC

 Remarks
 A: EXP.
 B: US MODEL
 C: AUSTRALIA MODEL
 D: CHINA MODEL

Ref. NO. 索引编号	Part NO. 部件编号	Inter- change ability 互换性	Part Name 部件名称	Q'ty 数量	Applicable Ser. No. 适用机号 范围	Remarks 备考
	44 - 00		ELECTRIC GROUP 电气构成			A B C D
1	44210 08200	Y	Battery (G&YU) 电瓶	1		(85D26R)
1	44210 06600	Y	Battery (DELKOR) 电瓶	1		(80D26R)
2	44220 25400		Cover 盖	1		
3	02832 06050		Rod 杠杆	2		
4	44364 06500		Thermo sensor 排气水温传感器	2	~5278	
4 -1	44364 08200	A	Thermo sensor 排气水温传感器	2	5279~	
5	36331 15500		Nipple 管接头	1		
6	03407 20016		Gasket 垫片	1		
7	44328 21800		Pressure switch 油压开关	1		
			(YANMAR 114250-39450)			
8	44346 16400		Relay (safety) 继电器 (安全)	1		
			(YANMAR 119802-77200)			
9	44327 05000		Relay (heater) 继电器 (加热器)	1		
			(YANMAR 119650-77910)			
10	44327 05000		Relay (solenoid) 继电器 (螺线管)	1		
			(YANMAR 119650-77910)			
11	02915 00006		Hexagon flange nut 法兰螺母	7		
12	44470 02100		Fuse box 保险盒	2		
	46934 05000		Fuse 保险	2		(5A)
13	44470 02600		Fuse box 保险盒	1		
	46934 05100		Fuse 保险	1		(30A)
14	44470 02900		Fuse box 保险盒	1		(50A)
15	44322 07300		Starter switch 启动开关	1		
	52739 00600		Key 键	2		
16	46921 02300		Silicon rectifier 整流器	1		
17	44250 38810		Bracket 支架 (板)	1		
18	44260 41100		Cover 盖	1		
19	02201 06016		Flange bolt 法兰螺栓	8		
20	03407 66842		Seal rubber 密封橡胶	1		
21	03407 64742		Seal rubber 密封橡胶	1		
22	46879 54300		Controller complete 控制器 (1组)	1	~0407	◎ ◎ ◎
22 -1	46870 51903	A	Controller 控制器	1	0408~	◎ ◎ ◎
22	46879 55900		Controller complete 控制器 (1组)	1	~0407	◎
22 -1	46870 54002	A	Controller 控制器	1	0408~	◎
23	44490 85430		Wiring harness 线束	1	~5470	◎ ◎ ◎
23 -1	44490 42540	B	Wiring harness 线束	1	5471~	◎ ◎ ◎
						w/o PRE-FILTER
23	44490 85430		Wiring harness 线束	1	~5442	◎ ◎ ◎
23 -1	44490 42540	B	Wiring harness 线束	1	5443~	◎ ◎ ◎
						w PRE-FILTER
23	44490 87130		Wiring harness 线束	1		◎
24	36110 05610		Instrument panel 仪表板	1		◎ ◎ ◎
24	36110 06010		Instrument panel 仪表板	1		◎
	02401 66020		Screw 螺钉	4		
25	07885 25140		Cable 线缆	1		(battery~starter)
	44462 05500		Insulator 绝缘 (套)	1		(battery "+")
	06540 15120		Corrugated tube 波纹软管	1		(protector)
26	44462 00800		Insulator 绝缘 (套)	1		(starter)
27	07888 51100		Cable 线缆	1		(earth)
	02201 10020	C	Flange bolt 法兰螺栓	1	7608~	
	02248 10020	D	Bolt, w/w 组合螺栓	1	7608~	

44 - 00 ELECTRIC

Remarks
 A: EXP.
 B: US MODEL
 C: AUSTRALIA MODEL
 D: CHINA MODEL

Ref. NO. 索引编号	Part NO. 部件编号	Inter- change ability 互换性	Part Name 部件名称		Q' ty 数量	Applicable Ser. No. 适用机号 范围	Remarks 备考
							A B C D
28	36159 02202		Sending unit	信号发生器	1		
	02915 00005		Hexagon flange nut	法兰螺母	5		
29	36153 01600		Gasket	垫片	1		
30	03425 00003		Vinyl clip	塑料卡扣	1		
31	03425 00001		Vinyl clip	塑料卡扣	10		
32	46811 24100		Solenoid valve	电磁阀	1		- ◎ - -
33	44328 20600		Pressure switch	压力开关	2		- ◎ - -
34	46242 21500		Push button switch	按钮开关	1		- ◎ - -
35	05068 23040	D	Cable	线缆	1	7608~	(earth)
	02248 10020	D	Bolt, w/w	组合螺栓	1	7608~	
36	02248 08020	D	Bolt, w/w	组合螺栓	1	7608~	(earth)

US/AUSTRALIA MODEL

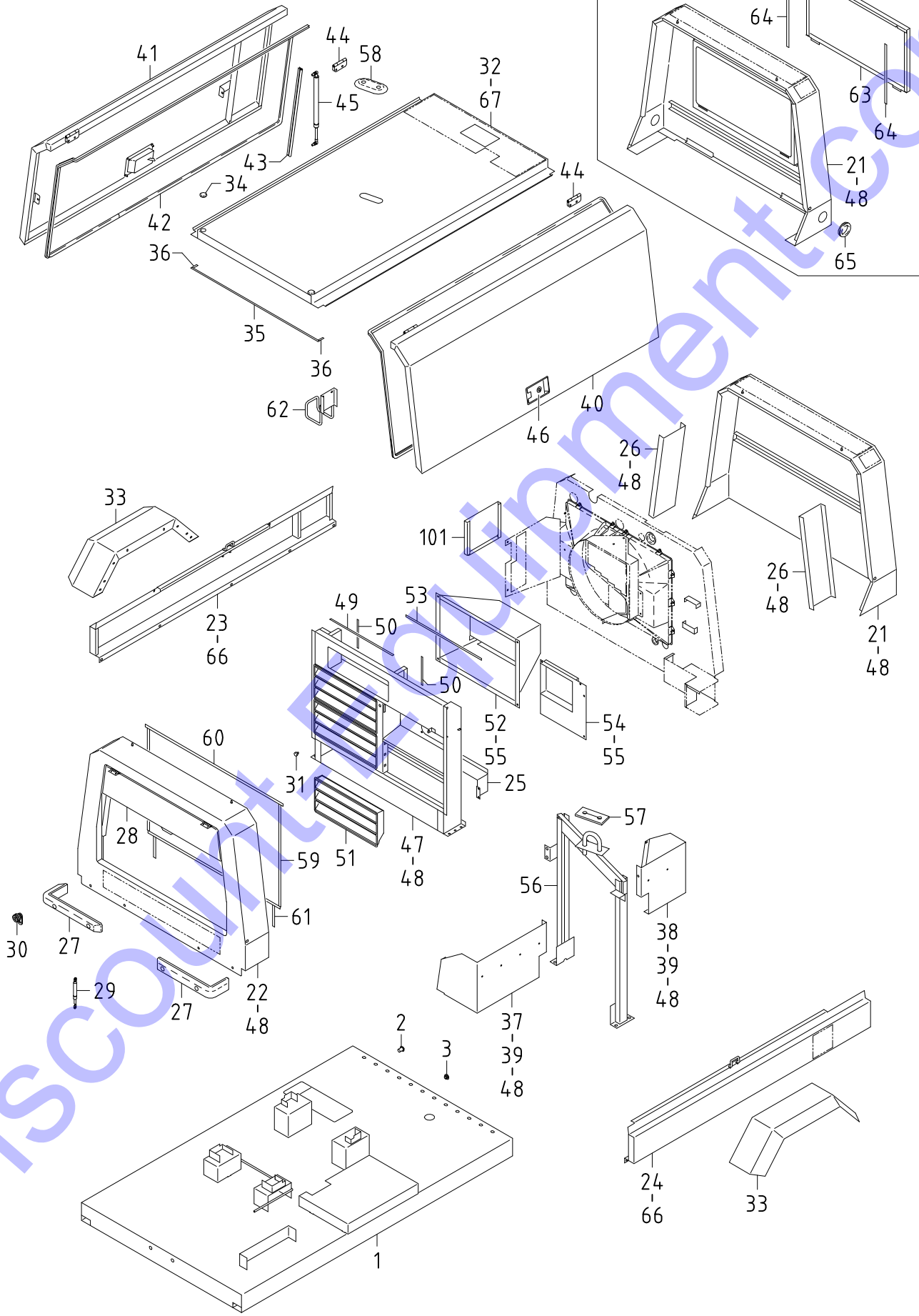

51 - 00 FRAME & BONNET

 Remarks
 A: EXP.
 B: US MODEL
 C: AUSTRALIA MODEL
 D: CHINA MODEL

Ref. NO. 索引编号	Part NO. 部件编号	Inter- change ability 互换性	Part Name 部件名称	Q'ty 数量	Applicable Ser. No. 适用机号 范围	Remarks 备考
	51 - 00		FRAME GROUP			A B C D
			底盘构成			
1	51100 34941		Frame	1		
2	37181 07400		Clip	4		◎
3	03403 10017		Grommet	2		◎ ◎
	52 - 00		BONNET GROUP			
			机壳构成			
21	52100 93220		Cover	1		◎ ◎
21	52100 97020		Cover	1		◎
21	52100 98520		Cover	1	~0483	◎
21 -1	52100 97020	B	Cover	1	0484~	◎
22	52100 96921		Cover	1		◎ ◎ ◎
22	52100 93521		Cover	1		◎
23	52400 18820		Side cover	1		
24	52400 18721		Side cover	1		
25	52350 74520	D	Cover	1	0103~	- ◎ - -
	02201 06016	D	Flange bolt	4	0103~	- ◎ - -
26	52550 19910		Side plate	2		
27	52728 31210		Cushion rubber	2		
	02246 08050		Bolt, w/w	6		
	52162 00200		Collar	6		
28	52450 28330		Door	1		
	02345 65010		Screw	4		
29	GE360 01300		Dumper	1	~1333	
29 -1	GE360 03200	A	Dumper	1	1334~	
	03322 06017		Pin	2		
	03116 12006		Plain washer	2		
	03310 16012	C	Split pin	2	0242~	
	56166 00900	D	Pin	2	0242~	
30	52723 00900		Lock	1		
31	GE240 01100		Rubber cushion	1	~0552	
31 -1	52728 35310	A	Cushion rubber	1	0553~	
32	52300 29020		Top cover	1		
33	53220 69901		Fender	2		◎ ◎ ◎
33	53220 69801		Fender	2		◎ ◎
	02246 06016		Bolt, w/w	12		
34	52746 02101		Cap	2		
35	03407 65009		Seal rubber	1		
36	03407 65029		Seal rubber	2		
37	52750 30301		Bracket	1	~5470	w/o PRE-FILTER
37 -1	52750 31400	B	Bracket	1	5471~	w/o PRE-FILTER
37	52750 30301		Bracket	1	~5442	w. PRE-FILTER
37 -1	52750 31400	B	Bracket	1	5443~	w. PRE-FILTER
38	52750 30401		Bracket	1		
39	02401 66016		Screw	2		
	02915 00006		Hexagon flange nut	2		
40	52450 26031		Door	1		
41	52450 26131		Door	1		
42	03407 64730		Seal rubber	2		
43	03407 67234		Seal rubber	2		
44	52480 14800		Hinge	4		
	02136 08016		Bolt	16		

51 - 00 FRAME & BONNET

 Remarks
 A: EXP.
 B: US MODEL
 C: AUSTRALIA MODEL
 D: CHINA MODEL

Ref. NO.	Part NO.	Inter-changeability	Part Name	Q'ty	Applicable Ser. No.	Remarks
索引编号	部件编号	互换性	部件名称	数量	适用机号范围	备考
						A B C D
45	GE360 03000		Dumper	4	~0921	
45 -1	GE360 03100	A	Dumper	4	0922~	
	02915 00008		Hexagon flange nut	8		
	45214 02300		Washer	4		
46	52710 03601		Latch ass'y	2		
	52739 03400		Key	2		
	02915 00006		Hexagon flange nut	8		
47	52370 79802		Duct	1		◎ ◎ ◎
47	52370 83401		Duct	1		◎
48	02201 08020		Flange bolt	26		
49	03407 68043		Seal rubber	1		
50	03407 68031		Seal rubber	2		
51	52370 81800		Duct	3		
52	52350 72220		Cover	1		
53	03407 68057		Seal rubber	1		
54	52350 72320		Cover	1		
55	02201 06016		Flange bolt	7		
	02915 00006		Hexagon flange nut	3		
56	52620 48200		Lifting bail	1	~0892	
56 -1	52620 48900	B	Lifting bail	1	0893~	
	02135 12030		Bolt	4		
	03115 02012		Spring washer	4		
	03116 12012		Plain washer	4		
57	52728 16110		Cushion rubber	1	~0193	
57 -1	52728 34810	A	Cushion rubber	1	0194~	
58	52746 01800		Cap	1		
59	03407 66942		Seal rubber	2		
60	03407 66927		Seal rubber	2		
61	03407 66956		Seal rubber	2		
62	02201 08020		Flange bolt	2		◎ ◎
	02915 00008		Hexagon flange nut	2		◎ ◎
62	52660 05100		Hook	1		◎ ◎
	02201 08020		Flange bolt	2		◎ ◎
63	52350 30120		Cover	1		◎
	02136 06035		Bolt	2		◎
	03115 06006		Spring washer	2		◎
	03116 15006		Plain washer	2		◎
63	52350 30120	D	Cover	1	0484~	◎
	02136 06035	D	Bolt	2	0484~	◎
	03115 06006	D	Spring washer	2	0484~	◎
	03116 15006	D	Plain washer	2	0484~	◎
64	03407 66839		Seal rubber	2		◎
64	03407 66839	D	Seal rubber	2	0484~	◎
65	03403 00592	D	Grommet	2	0484~	- - ◎ -
66	02246 08025		Bolt, w/w	10		
	02915 00008		Hexagon flange nut	6		
67	02246 08025		Bolt, w/w	6		
	39 - 00		ACCESSORY GROUP			附件构成
101	39200 09600		Tool box	1	~0338	
101 -1	39200 09901	A	Tool box	1	0339~	
	02709 00410		Tapping screw	4		

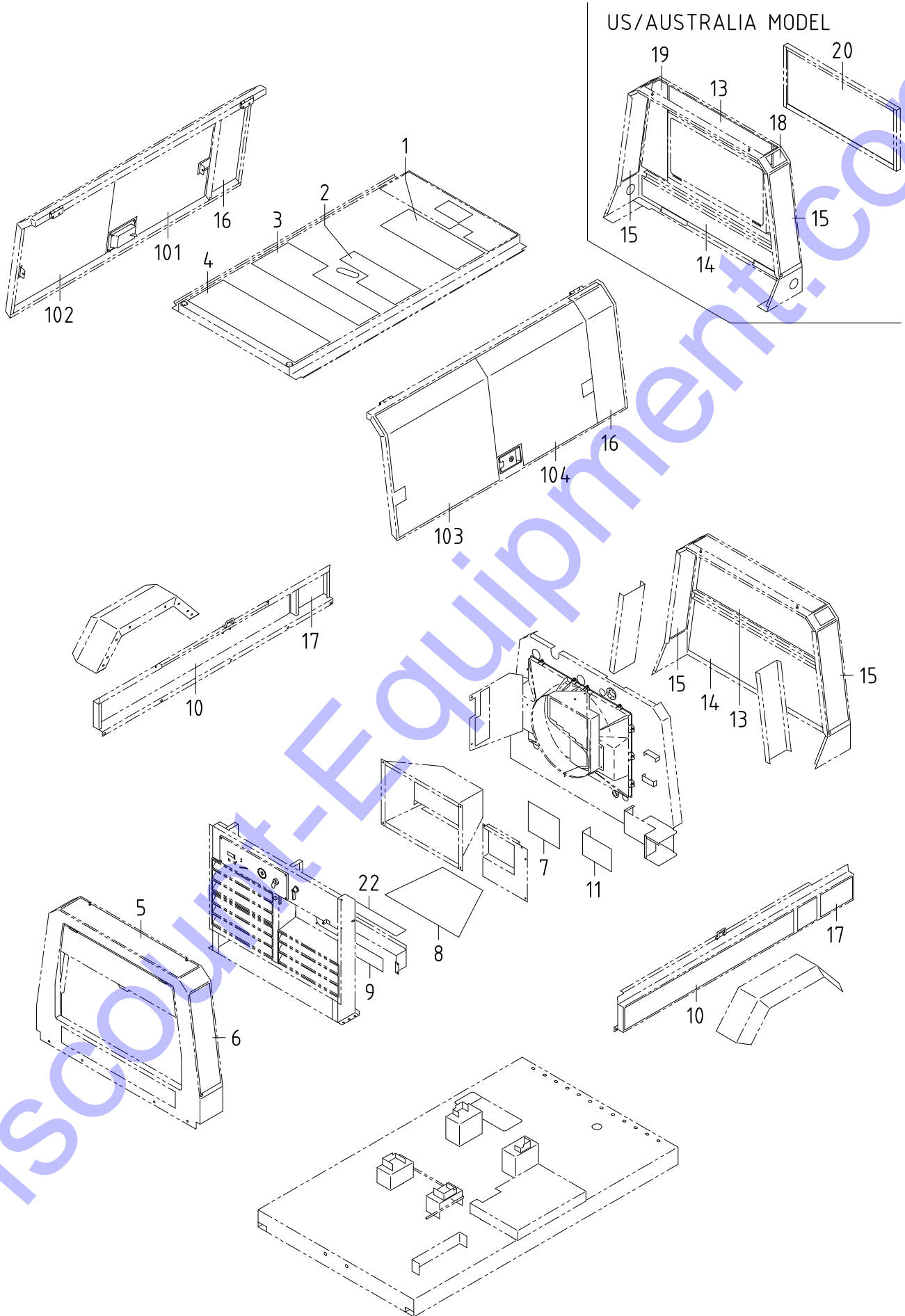

52 - 00 LINING

 Remarks
 A: EXP.
 B: US MODEL
 C: AUSTRALIA MODEL
 D: CHINA MODEL

Ref. NO. 索引编号	Part NO. 部件编号	Inter- change ability 互换性	Part Name 部件名称	Q'ty 数量	Applicable Ser. No. 适用机号 范围	Remarks 备考
	52900 02421		URETHANE FOAM KIT 合成橡胶套件 (Const. No. 1~17 & 20)			A B C D ◎ ◎ ◎
	52900 02722		URETHANE FOAM KIT 合成橡胶套件 (Const. No. 1~20 & 22)			◎ ◎ ◎
	52900 02421		URETHANE FOAM KIT 合成橡胶套件 (Const. No. 1~17 & 20)		~0483	◎ ◎ ◎
	52900 05020	B	URETHANE FOAM KIT 合成橡胶套件 (Const. No. 1~20)		0484~	◎ ◎ ◎
1	52959 14030		Lining 防音材	1		
2	52931 85920		Lining 防音材	1	~0102	
2 -1	52959 40840	A	Lining 防音材	1	0103~	
3	52931 86020		Lining 防音材	1	~0102	
3 -1	52959 14750	A	Lining 防音材	1	0103~	
4	52959 25930		Lining 防音材	1		
5	52959 15240	C	Lining 防音材	1	0103~	◎ ◎ ◎
5	52959 15240		Lining 防音材	1		◎ ◎ ◎
6	52959 88930	C	Lining 防音材	2	0103~	◎ ◎ ◎
6	52959 88930		Lining 防音材	2		◎ ◎ ◎
7	52959 21840		Lining 防音材	1		
8	52931 86120		Lining 防音材	1		
9	52959 69350		Lining 防音材	1		
10	52959 41340	C	Lining 防音材	2	0103~	◎ ◎ ◎
10	52959 41340		Lining 防音材	2	~0752	◎ ◎ ◎
10 -1	52959 41340	Q	Lining 防音材	1	0753~	◎ ◎ ◎
11	52959 96530	C	Lining 防音材	1	0103~	
12	* * *					
13	52939 08340		Lining 防音材	1		◎ ◎ ◎
13	52919 40020		Lining 防音材	1		◎ ◎ ◎
13	52939 08340		Lining 防音材	1	~0483	◎ ◎ ◎
13 -1	52919 40020	B	Lining 防音材	1	0484~	◎ ◎ ◎
14	52939 08440		Lining 防音材	1	~0102	◎ ◎ ◎
14 -1	52919 62410	A	Lining 防音材	1	0103~	◎ ◎ ◎
14	52919 18500		Lining 防音材	1		◎ ◎ ◎
14	52939 08440		Lining 防音材	1	~0102	◎ ◎ ◎
14 -1	52919 62410	A	Lining 防音材	1	~0483	◎ ◎ ◎
14 -2	52919 18500	B	Lining 防音材	1	0484~	◎ ◎ ◎
15	52919 09100		Lining 防音材	2		
16	52919 77420		Lining 防音材	2		
17	52919 17310		Lining 防音材	2		
18	52939 08540		Lining 防音材	1		◎ ◎ ◎
18	52939 08540	D	Lining 防音材	1	0484~	◎ ◎ ◎
19	52939 08640		Lining 防音材	1		◎ ◎ ◎
19	52939 08640	D	Lining 防音材	1	0484~	◎ ◎ ◎
20	52919 99620		Lining 防音材	1		◎ ◎ ◎
20	52919 99620	D	Lining 防音材	1	0484~	◎ ◎ ◎
21	* * *					
22	52959 70120	D	Lining 防音材	1	0103~	- ◎ - -

52 - 00 LINING

Remarks
 A: EXP.
 B: US MODEL
 C: AUSTRALIA MODEL
 D: CHINA MODEL

Ref. NO. 索引编号	Part NO. 部件编号	Inter- change ability 互换性	Part Name 部件名称	Q' ty 数量	Applicable Ser. No. 适用机号 范围	Remarks 备考
	52901 02421		URETHANE FOAM KIT 合成橡胶套件			A B C D ◎ ◎ ◎ ◎
	52901 02722		URETHANE FOAM KIT 合成橡胶套件			◎ ◎ ◎ ◎
	52901 02421		URETHANE FOAM KIT 合成橡胶套件		~0483	◎ ◎ ◎ ◎
	52901 05020	B	URETHANE FOAM KIT 合成橡胶套件		0484~	◎ ◎ ◎ ◎
(Const. No. 101~104)						
101	52978 16100		Lining 防音材	1		
102	52978 16200		Lining 防音材	1		
103	52978 16300		Lining 防音材	1		
104	52978 16400		Lining 防音材	1		

Discount-Equipment.com

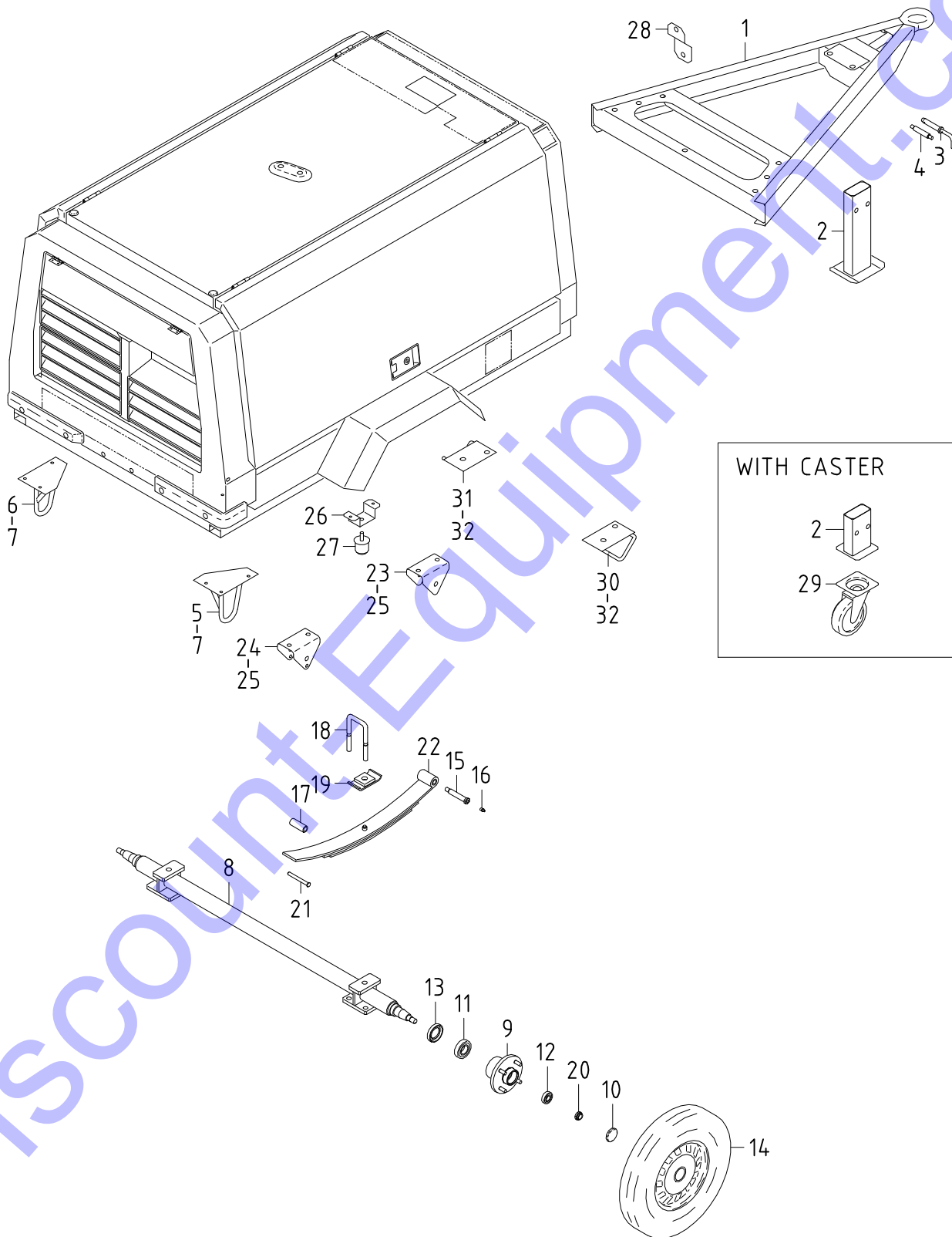

54 - 00 RUNNING & STEERING

Remarks
 A: EXP.
 B: US MODEL
 C: AUSTRALIA MODEL
 D: CHINA MODEL

Ref. NO. 索引编号	Part NO. 部件编号	Inter-changeability 互换性	Part Name 部件名称	Q'ty 数量	Applicable Ser. No. 适用机号范围	Remarks 备考
54 - 00 RUNNING GROUP 走行构成						A B C D
1	51300 22500		Draw bar 导杆	1		◎ ◎
	02135 16040		Bolt 螺栓	11		◎ (8) (8) ◎
	03115 02016		Spring washer 弹簧垫圈	11		◎ (8) (8) ◎
	03116 12016		Plain washer 平垫圈	11		◎ (8) (8) ◎
2	51410 24700		Stand (w. caster) 立柱	1		◎ ◎
2	51410 24600		Stand (w/o caster) 立柱	1		◎ ◎
3	51520 01700		Pin 销	1		◎ ◎
	51420 01001		Chain 栓锁	1		◎ ◎
	51420 01101		Chain 栓锁	1		◎ ◎
4	51434 03000		Bolt, stand 螺栓, 立柱	1		◎ ◎
	02915 00012		Hexagon flange nut 法兰螺母	2		◎ ◎
5	51550 04400		Stand, rear 立柱, 后	1		◎ (1) (1) ◎
6	51550 04500		Stand, rear 立柱, 后	1		◎ (1) (1) ◎
7	02201 10030		Flange bolt 法兰螺栓	6		◎ (6) (6) ◎
	02915 00010		Hexagon flange nut 法兰螺母	6		◎ (6) (6) ◎
8	54200 39400		Axle 主轴	1		◎ ◎
9	54341 04001		Hub 毂盖	2		◎ ◎
	54343 01900		Bolt 螺栓	8		◎ ◎
10	54342 00600		Cap 盖	2		◎ ◎
11	03410 30207		Bearing 轴承	2		◎ ◎
12	03410 30204		Bearing 轴承	2		◎ ◎
13	54345 00100		Oil seal 油封	2		◎ ◎
14	54420 06600		Tire ass'y 轮胎	2	~5925	◎ ◎
14 -1	54420 07200	A	Tire ass'y 轮胎	2	5926~	◎ ◎
	54344 01300		Nut 螺母	8		◎ ◎
15	54624 02400		Pin 销	4		◎ ◎
	02914 50014		Locking nut 自锁螺母	4		◎ ◎
	03116 12014		Plain washer 平垫圈	4		◎ ◎
16	03408 10010		Grease nipple 注脂口	4		◎ ◎
17	54622 00500		Bushing 衬套	2		◎ ◎
18	54627 05600		U-bolt U型螺栓	4		◎ ◎
	02914 50016		Locking nut 自锁螺母	8		◎ ◎
19	54628 04400		Pad 衬垫	2	~0241	◎ ◎
19 -1	54628 04700	A	Pad 衬垫	2	0242~	◎ ◎
20	54337 00500		Nut 螺母	2		◎ ◎
	03116 12018		Plain washer 平垫圈	2		◎ ◎
21	03322 12102		Pin 销	2		◎ ◎
	03116 12012		Plain washer 平垫圈	2		◎ ◎
	03310 30022		Split pin 开尾销	2		◎ ◎
22	54500 03700		Leaf spring ass'y 板簧	2		◎ ◎
23	51244 01300		Bracket, spring 支架(板), 弹簧	2		◎ ◎
24	51244 01400		Bracket, spring 支架(板), 弹簧	2		◎ ◎
25	02102 14030		Bolt 螺栓	8		◎ (8) (8) ◎
	03115 42014		Spring washer 弹簧垫圈	8		◎ (8) (8) ◎
26	54611 03200		Plate 板件	2		◎ ◎
	02201 08020		Flange bolt 法兰螺栓	4		◎ ◎
27	31130 26700		Vibration isolator ass'y 防振橡胶	2		◎ ◎
	02915 00012		Hexagon flange nut 法兰螺母	2		◎ ◎

54 - 00 RUNNING & STEERING

 Remarks
 A: EXP.
 B: US MODEL
 C: AUSTRALIA MODEL
 D: CHINA MODEL

Ref. NO. 索引编号	Part NO. 部件编号	Inter- change ability 互换性	Part Name 部件名称	Q' ty 数量	Applicable Ser. No. 适用机号 范围	Remarks 备考
28	51303 15000		Plate 板件	2		⊙
	02135 16040		Bolt 螺栓	4		⊙
	03115 02016		Spring washer 弹簧垫圈	4		⊙
	03116 12016		Plain washer 平垫圈	4		⊙
29	51460 02500		Caster 脚轮	1		⊙
	02201 10020		Flange bolt 法兰螺栓	4		⊙
	02915 00010		Hexagon flange nut 法兰螺母	4		⊙
30	52660 06000	D	Hook 吊钩	1	0312~	(1) (1)
31	52660 06100	D	Hook 吊钩	1	0312~	(1) (1)
32	02135 16040	D	Bolt 螺栓	4	0312~	(4) (4)
	03115 02016	D	Spring washer 弹簧垫圈	4	0312~	(4) (4)
	03116 12016	D	Plain washer 平垫圈	4	0312~	(4) (4)

ORDER MADE PARTS

SS1 - 00 WITHOUT TIRE TYPE (HIGHWAY TYPE)

Ref. NO.	Part NO.	Inter-change ability	Part Name	Q' ty	Applicable Ser. No.	Remarks
索引编号	部件编号	互换性	部件名称	数量	适用机号范围	备考

< CHANGED PART > < 不同部件 >

§ 31 - 00 MOUNTING, INTAKE, RECEIVER, refer to page
SEPARATOR & SERVICE HEADER 31-1

161	03620 41008		Plug	堵头	1	
-----	-------------	--	------	----	---	--

§ 51 - 00 FRAME & BONNET refer to page
51-1

3	03403 10017		Grommet	环形圈	2	
33	53220 69801		Fender	挡泥板	2	
	02201 06016		Flange bolt	法兰螺栓	12	

§ 54 - 00 RUNNING & STEERING refer to page
54-1

1	02135 16040		Bolt	螺栓	8	
	03115 02016		Spring washer	弹簧垫圈	8	
	03116 12016		Plain washer	平垫圈	8	
30	52660 06000		Hook	吊钩	1	
31	52660 06100		Hook	吊钩	1	
32	02135 16040		Bolt	螺栓	4	
	03115 02016		Spring washer	弹簧垫圈	4	
	03116 12016		Plain washer	平垫圈	4	

ORDER MADE PARTS

SS2 - 00 WITHOUT TIRE TYPE

Ref. NO.	Part NO.	Inter-change ability	Part Name	Q'ty	Applicable Ser. No.	Remarks
索引编号	部件编号	互换性	部件名称	数量	适用机号范围	备考

< ORDER MADE PART > < 专用部件 >

1	54610 02101		Bracket	支架(板)	2 ~7446	
1-1	54610 02101	Q	Bracket	支架(板)	1 7447~	
2	54610 01901		Bracket	支架(板)	1	
3	54610 02101		Bracket	支架(板)	1 ~7446	
3-1	54610 02200	B	Bracket	支架(板)	1 7447~	

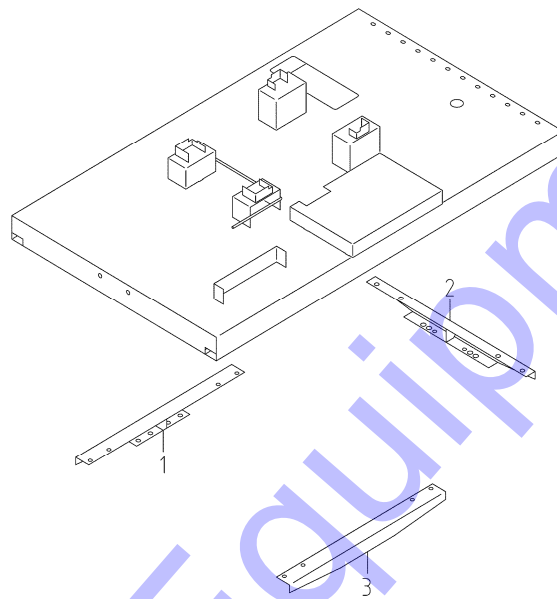

< CHANGED PART > < 不同部件 >

§ 51 - 00 FRAME & BONNET

refer to page 51-1

3	03403 10017		Grommet	环形圈	2	
23	52400 60121		Side cover	侧板	1	
24	52400 60021		Side cover	侧板	1	
33	53220 69801		Fender	挡泥板	2	
	02201 06016		Flange bolt	法兰螺栓	12	

§ 54 - 00 RUNNING & STEERING

refer to page 54-1

1	02135 16040		Bolt	螺栓	8	
	03115 02016		Spring washer	弹簧垫圈	8	
	03116 12016		Plain washer	平垫圈	8	
30	52660 06000		Hook	吊钩	1	
31	52660 06100		Hook	吊钩	1	
32	02135 16040		Bolt	螺栓	4	
	03115 02016		Spring washer	弹簧垫圈	4	
	03116 12016		Plain washer	平垫圈	4	

I N D E X

PART NO.	PAGE	REF. NO.	PART NO.	PAGE	REF. NO.	PART NO.	PAGE	REF. NO.
02102 14030	54 - 2	25	02201 08030	41 - 4	113-1	02915 00008	51 - 3	45-1
02135 08060	21 - 4	137	02201 08070	41 - 3	90-1	02915 00008	51 - 3	62
02135 10020	31 - 2	1	02201 10020	31 - 3	122-1	02915 00008	51 - 3	66
02135 12030	51 - 3	56-1	02201 10020	37 - 2	1-1	02915 00010	54 - 2	7
02135 16040	54 - 2	1	02201 10020	44 - 2	27	02915 00010	54 - 3	29
02135 16040	54 - 3	28	02201 10020	54 - 3	29	02915 00012	54 - 2	4
02135 16040	54 - 3	32	02201 10030	54 - 2	7	02915 00012	54 - 2	27
02135 16040	SS1- 1	1	02238 08020	36 - 2	17-2	02915 01008	41 - 2	42
02135 16040	SS1- 1	32	02238 08020	36 - 3	31	02915 20006	36 - 2	30
02135 16040	SS2- 1	1	02246 06016	51 - 2	33	02915 20008	31 - 2	2
02135 16040	SS2- 1	32	02246 08025	51 - 3	66	02915 20008	36 - 3	31
02136 06035	51 - 3	63	02246 08025	51 - 3	67	02915 20012	31 - 2	3
02136 06035	51 - 3	63	02246 08050	51 - 2	27	03115 02008	21 - 4	137
02136 08016	51 - 2	44	02248 06012	41 - 3	87	03115 02008	37 - 2	4
02136 10035	41 - 2	42	02248 08020	44 - 3	36	03115 02010	31 - 2	1
02138 08016	36 - 3	31	02248 10020	36 - 3	38	03115 02012	21 - 4	138
02138 08030	37 - 2	4	02248 10020	44 - 2	27	03115 02012	51 - 3	56-1
02138 12030	21 - 4	138	02248 10020	44 - 3	35	03115 02016	54 - 2	1
02138 12040	21 - 4	138	02270 04012	21 - 3	85	03115 02016	54 - 3	28
02201 06016	37 - 2	20-1	02280 08030	21 - 2	17	03115 02016	54 - 3	32
02201 06016	37 - 3	71	02280 10030	21 - 2	1-2	03115 02016	SS1- 1	1
02201 06016	41 - 2	7	02280 10030	21 - 2	9	03115 02016	SS1- 1	32
02201 06016	41 - 3	91	02280 10030	21 - 2	29	03115 02016	SS2- 1	1
02201 06016	44 - 2	19	02280 10045	21 - 2	32	03115 02016	SS2- 1	32
02201 06016	51 - 2	25	02280 10055	21 - 2	9	03115 06006	51 - 3	63
02201 06016	51 - 3	55	02280 10075	21 - 2	1-2	03115 06006	51 - 3	63
02201 06016	SS1- 1	33	02280 10075	21 - 3	71-1	03115 06010	41 - 2	42
02201 06016	SS2- 1	33	02282 08025	21 - 3	77	03115 30010	21 - 2	29
02201 08012	31 - 2	41	02282 10030	21 - 4	136	03115 30010	21 - 2	32
02201 08020	31 - 2	42	02283 06025	36 - 2	19	03115 30010	21 - 3	71-1
02201 08020	31 - 2	81-1	02283 10030	31 - 4	127-1	03115 30010	21 - 4	136
02201 08020	31 - 3	81	02283 10035	31 - 3	122-1	03115 30010	31 - 4	127-1
02201 08020	31 - 3	122-1	02283 10035	31 - 4	127	03115 31010	31 - 3	122-1
02201 08020	31 - 4	163	02283 10045	31 - 3	122-1	03115 40006	36 - 2	19
02201 08020	36 - 3	31	02345 65010	51 - 2	28	03115 40008	21 - 2	17
02201 08020	37 - 2	20	02401 66016	51 - 2	39	03115 42014	54 - 2	25
02201 08020	37 - 3	73	02401 66020	44 - 2	24	03116 12006	36 - 2	30
02201 08020	41 - 2	6	02709 00410	51 - 3	101-1	03116 12006	51 - 2	29-1
02201 08020	41 - 2	45	02832 06050	44 - 2	3	03116 12008	37 - 2	4
02201 08020	41 - 2	45	02912 06010	41 - 2	42	03116 12012	51 - 3	56-1
02201 08020	41 - 2	46	02914 50014	54 - 2	15	03116 12012	54 - 2	21
02201 08020	41 - 4	112	02914 50016	54 - 2	18	03116 12014	54 - 2	15
02201 08020	41 - 4	113	02914 60008	36 - 2	28	03116 12016	54 - 2	1
02201 08020	51 - 3	48	02915 00005	44 - 3	28	03116 12016	54 - 3	28
02201 08020	51 - 3	62	02915 00006	37 - 3	68	03116 12016	54 - 3	32
02201 08020	51 - 3	62	02915 00006	44 - 2	11	03116 12016	SS1- 1	1
02201 08020	54 - 2	26	02915 00006	51 - 2	39	03116 12016	SS1- 1	32
02201 08030	41 - 2	45	02915 00006	51 - 3	46	03116 12016	SS2- 1	1
02201 08030	41 - 2	45	02915 00006	51 - 3	55	03116 12016	SS2- 1	32
02201 08030	41 - 3	104	02915 00008	41 - 2	47	03116 12018	54 - 2	20

I N D E X

PART NO.	PAGE	REF. NO.	PART NO.	PAGE	REF. NO.	PART NO.	PAGE	REF. NO.			
03116	15006	51 - 3	63	03407	66839	51 - 3	64	03600	08021	41 - 3	94-1
03116	15006	51 - 3	63	03407	66839	51 - 3	64	03600	08031	41 - 3	94
03116	15010	41 - 2	42	03407	66842	37 - 3	80	03600	08037	41 - 3	95
03260	03010	39 - 2	1	03407	66842	44 - 2	20	03600	08050	41 - 3	97
03307	10040	21 - 2	31	03407	66923	37 - 3	76	03600	08076	41 - 3	96
03307	14050	21 - 4	135	03407	66927	51 - 3	60	03600	08080	41 - 3	98
03310	16012	51 - 2	29-1	03407	66942	51 - 3	59	03600	08105	41 - 3	95
03310	30022	54 - 2	21	03407	66956	51 - 3	61	03600	09012	41 - 3	93
03316	08020	21 - 4	139	03407	67234	51 - 2	43	03600	09012	41 - 3	99
03316	14028	21 - 2	4	03407	67304	37 - 3	78	03611	08075	37 - 2	46
03322	06017	51 - 2	29-1	03407	68012	37 - 3	74	03620	41002	37 - 3	56
03322	12102	54 - 2	21	03407	68031	51 - 3	50	03620	41004	41 - 2	10
03402	10070	21 - 3	78	03407	68043	51 - 3	49	03620	41006	31 - 3	84
03402	10095	21 - 2	7	03407	68057	51 - 3	53	03620	41006	31 - 3	94
03402	10125	21 - 3	74	03407	68060	37 - 3	75	03620	41008	SS1- 1	161
03402	10125	21 - 3	93	03408	10010	54 - 2	16	03620	60001	21 - 2	2-1
03402	15050	31 - 4	126	03410	06209	21 - 2	30	03620	60001	21 - 2	10
03402	15075	31 - 4	166	03410	06211	21 - 2	11	03620	60002	21 - 2	2
03402	15095	21 - 2	7-1	03410	30204	54 - 2	12	03620	60002	21 - 2	34
03402	15140	31 - 4	125	03410	30207	54 - 2	11	03620	60002	21 - 3	75
03402	15145	31 - 4	125-1	03413	10055	21 - 2	12	03620	60002	21 - 3	75-1
03402	25008	21 - 3	89	03413	20052	21 - 2	26	03620	60002	21 - 3	97
03402	25014	41 - 3	88	03413	20090	21 - 2	21	03620	60002	36 - 2	12
03402	25021	21 - 3	91	03413	40020	21 - 2	25	03620	60002	36 - 2	12
03402	25024	37 - 2	13	03424	80039	41 - 2	6	03730	04110	31 - 3	90
03402	25029	31 - 4	129	03424	80101	41 - 4	111	03731	21002	36 - 2	9
03402	25029	31 - 4	129-1	03425	00001	36 - 3	43	03731	21004	31 - 3	89
03402	25030	31 - 3	83	03425	00001	41 - 3	109	03731	30002	36 - 2	14
03402	25032	31 - 4	168	03425	00001	44 - 3	31	03731	42002	37 - 3	53
03402	25038	31 - 4	174	03425	00003	44 - 3	30	03731	42003	37 - 3	62
03402	25044	31 - 3	87	03511	10013	41 - 4	114	03731	42008	31 - 4	162
03402	25045	37 - 2	6	03511	10013	41 - 4	114	03731	44002	36 - 2	13
03403	00303	37 - 3	81	03511	10017	41 - 3	103	03732	00602	36 - 2	10
03403	00392	37 - 3	82	03511	20035	41 - 2	5	03734	20015	36 - 2	16
03403	00392	37 - 3	82-1	03511	20040	37 - 3	51	03734	20201	37 - 2	19
03403	00512	37 - 3	52	03511	20070	31 - 2	44	03734	21010	21 - 2	3
03403	00592	51 - 3	65	03511	20090	31 - 2	45	03734	21015	36 - 2	16-1
03403	10017	51 - 2	3	03511	20100	31 - 2	47	03734	21020	37 - 2	18
03403	10017	SS1- 1	3	03511	20110	31 - 2	48	03734	21030	31 - 3	88
03403	10017	SS2- 1	3	03511	40006	41 - 4	110	03734	21030	37 - 3	65
03407	16022	41 - 2	3	03511	40016	37 - 3	60	03734	21151	36 - 2	3
03407	16022	41 - 2	12	03511	40016	41 - 3	101	03734	52021	21 - 3	96
03407	20016	44 - 2	6	03511	40016	41 - 3	101	03734	53021	21 - 3	95
03407	44053	37 - 3	77	03511	40018	37 - 2	47	03734	53021	21 - 3	96-1
03407	64632	37 - 2	45	03511	40020	41 - 3	102	03734	64020	36 - 3	39
03407	64730	51 - 2	42	03511	40020	41 - 4	114-1	03734	64028	36 - 2	15
03407	64742	44 - 2	21	03511	40020	41 - 4	114-1	03734	64028	36 - 3	49
03407	65009	51 - 2	35	03580	19070	41 - 2	4	03734	65020	36 - 3	37
03407	65029	51 - 2	36	03600	06050	41 - 4	110	03734	65020	36 - 3	41
03407	66819	37 - 3	79	03600	08020	41 - 3	89	03734	65020	36 - 3	41

I N D E X

PART NO.	PAGE	REF. NO.	PART NO.	PAGE	REF. NO.	PART NO.	PAGE	REF. NO.
03734 65020	36 - 3	46	21406 28700	21 - 2	24	31144 16000	36 - 2	26-2
03734 65024	36 - 3	46-1	21406 29900	21 - 2	20	32100 40700	31 - 2	31
03734 65028	36 - 2	15	21412 07600	21 - 4	132	32100 44900	31 - 2	35
03734 65028	36 - 3	42	21425 03800	21 - 4	131	32142 08600	31 - 2	33
03734 66020	36 - 3	40	21441 04800	21 - 3	81	32142 11300	31 - 2	37
03734 70021	31 - 4	131	21441 04900	21 - 3	82	32143 11700	31 - 2	32
03734 75060	37 - 2	10	21461 31600	21 - 2	18	32143 11800	31 - 2	36
03734 75060	37 - 2	21	21462 22300	21 - 2	19	32143 12900	31 - 2	49
03734 76060	37 - 2	21-1	21467 40900	21 - 3	62	32143 13000	31 - 2	50
03734 85140	31 - 3	86	21468 02700	21 - 2	23	32147 03600	31 - 2	39
03735 13002	36 - 2	11	21468 04400	21 - 4	136	32148 00100	31 - 2	40
03735 13002	37 - 3	54	21468 09200	21 - 2	28	32151 01400	31 - 2	34
03735 13003	37 - 3	63	21468 19800	21 - 2	32	32151 01600	31 - 2	38
03735 13004	31 - 3	91	21469 31500	21 - 3	63	32240 42501	31 - 2	42
03735 13004	41 - 2	8	21470 14300	21 - 2	22	32331 78700	31 - 2	46
03830 08004	41 - 2	47	21470 14400	21 - 2	27	32331 78800	31 - 2	43
03840 15060	36 - 2	4	22100 41201	21 - 3	71	33100 76010	31 - 3	81
03841 20087	37 - 2	17	22100 42902	21 - 3	71-1	33100 76110	31 - 2	81
03841 30015	31 - 3	88	22111 28200	21 - 3	72	33100 76110	31 - 2	81
03851 30032	37 - 3	64	22115 11300	21 - 3	77	33100 76610	31 - 3	81
03890 20020	36 - 3	35-1	22115 12701	21 - 3	73	33100 76710	31 - 3	81
03890 20020	36 - 3	36	22123 04400	36 - 2	29	33100 78610	31 - 3	81
03890 20020	36 - 3	44	22123 05100	36 - 2	29-1	33100 78610	31 - 3	81
03890 20024	36 - 2	7	22130 05500	36 - 2	21	33100 81710	31 - 3	81
03890 20025	36 - 3	34	22130 09500	21 - 3	80	33100 84610	31 - 2	81-1
03890 20030	36 - 3	33	22144 07700	31 - 4	170	33100 85810	31 - 3	81-1
03890 20030	36 - 3	35	22144 10600	21 - 3	86	33100 85810	31 - 3	81-1
03890 20035	36 - 2	6	22144 12800	36 - 2	25	33231 02500	31 - 3	82
03890 20077	36 - 2	7	22144 16600	21 - 3	84	33231 03600	31 - 3	82
03890 25027	36 - 3	35-2	22144 16700	21 - 3	83	33231 04000	31 - 3	82
03890 30046	36 - 3	32	22150 13801	21 - 3	79	33238 01600	31 - 4	128
03890 30046	36 - 3	48	22152 04900	36 - 2	20	33238 01600	31 - 4	128-1
05068 23040	44 - 3	35	22153 03400	21 - 2	5	33410 03600	31 - 4	171
06540 07060	36 - 2	4	22200 16100	37 - 2	14	33410 03800	31 - 4	171-1
06540 07085	37 - 2	17	22314 02101	21 - 2	14-1	34210 32600	31 - 3	121
06540 15120	44 - 2	25	22314 02201	21 - 2	16-1	34210 32900	31 - 3	121-1
07885 25140	44 - 2	25	22314 02500	21 - 2	14	34220 16101	31 - 3	123
07888 51100	44 - 2	27	22314 06200	21 - 2	16	34224 03000	31 - 3	123-1
21201 41502	21 - 2	1	23124 10300	36 - 2	22	34232 00300	36 - 2	27
21201 43900	21 - 2	1-1	23124 15600	21 - 3	76	34250 18301	31 - 3	124
21201 45100	21 - 2	1-2	31110 06910	31 - 2	1	34250 30501	31 - 3	124-1
21211 10800	21 - 2	8	31120 08900	31 - 2	4	34260 07000	31 - 4	130
21212 18300	21 - 2	6	31130 14200	31 - 2	2	35100 53100	31 - 3	122
21212 18500	21 - 2	5	31130 20500	31 - 2	3	35100 53901	31 - 3	122-1
21214 18100	21 - 3	61	31130 26700	54 - 2	27	35108 07300	31 - 3	122
21217 33300	21 - 2	9	31130 27000	41 - 2	49	35108 07500	31 - 3	122-1
21218 33400	21 - 2	15	31130 27000	41 - 2	49-1	35200 14100	31 - 3	93
21218 33500	21 - 2	13	31131 04900	37 - 2	44	35200 15200	31 - 3	84
21221 02100	21 - 3	92	31144 14400	36 - 2	26	35200 19500	31 - 3	84
21222 09600	21 - 2	33	31144 14500	36 - 2	26-1	35200 21400	31 - 3	84-1

I N D E X

PART NO.	PAGE	REF. NO.	PART NO.	PAGE	REF. NO.	PART NO.	PAGE	REF. NO.			
35300	17000	31 - 4	164	37181	03600	37 - 3	61	39176	05410	39 - 3	33
35301	20200	31 - 4	165	37181	03600	41 - 3	108	39176	09710	39 - 4	43
35303	03300	31 - 4	169	37181	07400	51 - 2	2	39176	50000	39 - 3	36
35303	08400	31 - 4	167	37187	01200	31 - 4	172	39176	59300	39 - 3	34
35421	00105	31 - 4	161	37189	03300	36 - 3	45	39176	69300	39 - 2	10
35421	01600	36 - 2	5	37189	19700	36 - 3	47	39176	69500	39 - 2	12
35421	05500	41 - 3	87	37189	34400	37 - 2	15	39176	69500	39 - 2	14
35421	07700	31 - 4	161	37189	37000	36 - 2	10	39176	69600	39 - 2	15
35470	41200	31 - 4	163	37215	02800	37 - 2	4	39176	69700	39 - 2	16
36110	05610	44 - 2	24	37231	02100	37 - 2	5	39176	69800	39 - 2	17
36110	06010	44 - 2	24	37400	16100	37 - 2	1	39176	73300	39 - 2	18
36131	03100	36 - 2	2	37400	16200	37 - 2	1-1	39176	73400	39 - 3	19
36141	15503	36 - 2	1	37411	07600	37 - 2	2	39176	73500	39 - 3	20
36141	18600	36 - 2	1	37411	07801	37 - 2	2-1	39176	73600	39 - 3	21
36152	02500	36 - 2	3	37438	08900	37 - 2	3	39176	73800	39 - 3	22
36153	01600	44 - 3	29	37510	37400	37 - 2	20	39176	78500	39 - 2	10
36159	02202	44 - 3	28	37510	38100	37 - 2	20-1	39176	78700	39 - 2	18
36221	04500	36 - 3	31	37580	01900	37 - 2	16	39176	78800	39 - 3	19
36280	33301	36 - 2	30	37730	02001	31 - 3	92	39176	78900	39 - 3	20
36331	15500	44 - 2	5	37740	01400	31 - 3	94	39176	78900	39 - 3	22
36349	22400	21 - 3	94	38100	43600	37 - 2	41	39176	79000	39 - 3	21
36349	22800	21 - 3	94-1	38200	32500	37 - 2	48	39176	79200	39 - 2	12
36400	19000	36 - 2	8	38410	05700	37 - 2	41	39176	79200	39 - 2	14
36400	21901	36 - 2	17	38420	95400	37 - 2	42	39176	79300	39 - 2	15
36400	23200	36 - 2	17-1	38420	96000	37 - 2	43	39176	79400	39 - 2	16
36400	23800	36 - 2	17-2	38440	08410	37 - 3	66	39176	79500	39 - 2	17
36421	03600	36 - 2	18	38440	08510	37 - 3	67	39176	79500	39 - 3	35
36422	01900	36 - 2	19	38450	86000	37 - 3	70	39178	00310	39 - 3	37
36428	00700	21 - 3	88	38450	86100	37 - 3	69	39178	01340	39 - 2	8
36428	01100	21 - 3	88-1	38450	87700	37 - 3	70-1	39178	12630	39 - 4	41
36429	00801	21 - 3	87	38465	11901	41 - 3	84	39178	13330	39 - 4	40
36429	01300	21 - 3	87-1	38524	70500	37 - 2	49	39178	16320	39 - 3	37
36429	01600	21 - 3	87-2	38524	70600	37 - 3	50	39178	22030	39 - 2	8
36435	01400	36 - 2	24	38590	01400	37 - 3	57	39178	23930	39 - 2	3
36437	01500	36 - 2	23	38591	00400	37 - 3	58	39178	24030	39 - 2	4
36621	01401	21 - 3	85	38594	04900	37 - 3	59	39178	25210	39 - 3	37
36623	00800	21 - 3	90	39103	10811	39 - 2	1	39178	37310	39 - 4	38
36623	00900	21 - 3	90-1	39147	00602	39 - 3	29	39178	43110	39 - 4	39
36711	23500	36 - 3	38	39147	02800	39 - 3	29	39178	45140	39 - 4	42-1
37110	04600	37 - 2	11	39153	67300	39 - 2	6	39178	63100	39 - 3	31
37110	08300	37 - 2	11-1	39153	67400	39 - 2	6	39178	63200	39 - 3	32
37111	22302	37 - 2	7	39153	67500	39 - 2	6	39178	64130	39 - 2	5
37111	23100	37 - 2	7-1	39170	02000	39 - 2	2	39178	64530	39 - 2	5
37112	49000	37 - 2	8	39173	02100	39 - 3	23	39178	64630	39 - 2	5
37112	49700	37 - 2	8-1	39173	04200	39 - 2	13	39178	72410	39 - 4	42
37114	25000	37 - 2	9	39176	04810	39 - 2	7	39178	99730	39 - 2	8
37114	26000	37 - 2	9-1	39176	04910	39 - 3	33	39179	02201	39 - 3	29
37160	47910	31 - 3	85	39176	05110	39 - 3	30	39189	17100	39 - 3	24
37170	02900	41 - 2	9	39176	05210	39 - 2	7	39189	17200	39 - 3	25
37170	14000	37 - 3	55	39176	05310	39 - 3	30	39189	17300	39 - 3	26

I N D E X

PART NO.	PAGE	REF. NO.	PART NO.	PAGE	REF. NO.	PART NO.	PAGE	REF. NO.			
39189	17400	39 - 3	27	44322	07300	44 - 2	15	52162	00200	51 - 2	27
39189	17600	39 - 3	24	44327	05000	44 - 2	9	52162	00300	41 - 2	49
39189	17700	39 - 3	25	44327	05000	44 - 2	10	52162	00300	41 - 2	49-1
39189	17800	39 - 3	26	44328	20600	44 - 3	33	52300	29020	51 - 2	32
39189	17900	39 - 3	27	44328	21800	44 - 2	7	52350	30120	51 - 3	63
39189	18000	39 - 3	28	44346	16400	44 - 2	8	52350	30120	51 - 3	63
39189	19100	39 - 3	28	44364	06500	44 - 2	4	52350	70022	37 - 3	72
39200	09600	51 - 3	101	44364	08200	44 - 2	4-1	52350	72220	51 - 3	52
39200	09901	51 - 3	101-1	44462	00800	44 - 2	26	52350	72320	51 - 3	54
41250	05600	41 - 2	7	44462	05500	44 - 2	25	52350	74520	51 - 2	25
41290	01100	41 - 2	11	44470	02100	44 - 2	12	52370	79802	51 - 3	47
41290	01100	41 - 2	11-2	44470	02600	44 - 2	13	52370	81800	51 - 3	51
41290	01200	41 - 2	11-1	44470	02900	44 - 2	14	52370	83401	51 - 3	47
41330	00700	41 - 2	12-1	44490	42540	44 - 2	23-1	52400	18721	51 - 2	24
42100	81400	41 - 2	41	44490	42540	44 - 2	23-1	52400	18820	51 - 2	23
42210	02700	41 - 2	48	44490	85430	44 - 2	23	52400	60021	SS2- 1	24
42240	30202	41 - 2	45	44490	85430	44 - 2	23	52400	60121	SS2- 1	23
42310	96901	41 - 2	42	44490	87130	44 - 2	23	52450	26031	51 - 2	40
42324	13600	41 - 2	44	45214	02200	41 - 2	49	52450	26131	51 - 2	41
42324	14900	41 - 2	43	45214	02200	41 - 2	49-1	52450	28330	51 - 2	28
43100	43802	41 - 3	81	45214	02300	51 - 3	45-1	52480	14800	51 - 2	44
43100	75500	41 - 3	81-1	46242	21500	44 - 3	34	52550	19910	51 - 2	26
43210	01700	41 - 3	83	46811	24100	44 - 3	32	52620	48200	51 - 3	56
43220	02200	41 - 3	82	46870	51903	44 - 2	22-1	52620	48900	51 - 3	56-1
43220	03000	41 - 3	82-1	46870	54002	44 - 2	22-1	52660	05100	51 - 3	62
43310	31300	41 - 3	85	46879	54300	44 - 2	22	52660	06000	54 - 3	30
43310	31700	41 - 3	85-1	46879	55900	44 - 2	22	52660	06000	SS1- 1	30
43322	06200	41 - 3	86	46921	02300	44 - 2	16	52660	06000	SS2- 1	30
43322	06200	41 - 3	86-1	46934	05000	44 - 2	12	52660	06100	54 - 3	31
43510	11400	41 - 3	94-2	46934	05100	44 - 2	13	52660	06100	SS1- 1	31
43510	11700	41 - 3	95-1	51100	34941	51 - 2	1	52660	06100	SS2- 1	31
43525	01800	41 - 3	92	51244	01300	54 - 2	23	52710	03601	51 - 3	46
43531	02000	41 - 3	107	51244	01400	54 - 2	24	52723	00900	51 - 2	30
43532	05201	41 - 2	2	51300	22500	54 - 2	1	52728	16110	51 - 3	57
43532	09200	41 - 3	106	51303	15000	54 - 3	28	52728	31210	51 - 2	27
43534	01702	41 - 2	1	51410	24600	54 - 2	2	52728	34810	51 - 3	57-1
43534	05000	41 - 3	105	51410	24700	54 - 2	2	52728	35310	51 - 2	31-1
43540	08100	41 - 3	104	51420	01001	54 - 2	3	52739	00600	44 - 2	15
43541	02400	41 - 3	104	51420	01101	54 - 2	3	52739	03400	51 - 3	46
43543	01400	41 - 3	100	51434	03000	54 - 2	4	52744	03100	36 - 2	30
43543	01400	41 - 3	100-2	51460	02500	54 - 3	29	52746	01800	51 - 3	58
43543	01800	41 - 3	100-1	51520	01700	54 - 2	3	52746	02101	51 - 2	34
43550	02900	41 - 3	90	51550	04400	54 - 2	5	52750	30301	51 - 2	37
43550	03200	41 - 3	90-1	51550	04500	54 - 2	6	52750	30301	51 - 2	37
43650	02700	41 - 3	91	52100	93220	51 - 2	21	52750	30401	51 - 2	38
44210	06600	44 - 2	1	52100	93521	51 - 2	22	52750	31400	51 - 2	37-1
44210	08200	44 - 2	1	52100	96921	51 - 2	22	52750	31400	51 - 2	37-1
44220	25400	44 - 2	2	52100	97020	51 - 2	21	52919	09100	52 - 2	15
44250	38810	44 - 2	17	52100	97020	51 - 2	21-1	52919	17310	52 - 2	17
44260	41100	44 - 2	18	52100	98520	51 - 2	21	52919	18500	52 - 2	14

I N D E X

PART NO.	PAGE	REF. NO.	PART NO.	PAGE	REF. NO.	PART NO.	PAGE	REF. NO.
52919 18500	52 - 2	14-2	54420 07200	54 - 2	14-1			
52919 40020	52 - 2	13	54500 03700	54 - 2	22			
52919 40020	52 - 2	13-1	54610 01901	SS2- 1	2			
52919 62410	52 - 2	14-1	54610 02101	SS2- 1	1			
52919 62410	52 - 2	14-1	54610 02101	SS2- 1	1-1			
52919 77420	52 - 2	16	54610 02101	SS2- 1	3			
52919 99620	52 - 2	20	54610 02200	SS2- 1	3-1			
52919 99620	52 - 2	20	54611 03200	54 - 2	26			
52931 85920	52 - 2	2	54622 00500	54 - 2	17			
52931 86020	52 - 2	3	54624 02400	54 - 2	15			
52931 86120	52 - 2	8	54627 05600	54 - 2	18			
52939 08340	52 - 2	13	54628 04400	54 - 2	19			
52939 08340	52 - 2	13	54628 04700	54 - 2	19-1			
52939 08440	52 - 2	14	56166 00900	51 - 2	29-1			
52939 08440	52 - 2	14	61111 13300	21 - 4	133			
52939 08540	52 - 2	18	61122 05400	21 - 4	134			
52939 08540	52 - 2	18	GD920 14300	31 - 4	173			
52939 08640	52 - 2	19	GD920 14700	37 - 2	12			
52939 08640	52 - 2	19	GE240 01100	51 - 2	31			
52959 14030	52 - 2	1	GE360 01300	51 - 2	29			
52959 14750	52 - 2	3-1	GE360 03000	51 - 3	45			
52959 15240	52 - 2	5	GE360 03100	51 - 3	45-1			
52959 15240	52 - 2	5	GE360 03200	51 - 2	29-1			
52959 21840	52 - 2	7						
52959 25930	52 - 2	4						
52959 40840	52 - 2	2-1						
52959 41340	52 - 2	10						
52959 41340	52 - 2	10						
52959 41340	52 - 2	10-1						
52959 69350	52 - 2	9						
52959 70120	52 - 2	22						
52959 88930	52 - 2	6						
52959 88930	52 - 2	6						
52959 96530	52 - 2	11						
52978 16100	52 - 3	101						
52978 16200	52 - 3	102						
52978 16300	52 - 3	103						
52978 16400	52 - 3	104						
53220 69801	51 - 2	33						
53220 69801	SS1- 1	33						
53220 69801	SS2- 1	33						
53220 69901	51 - 2	33						
54200 39400	54 - 2	8						
54337 00500	54 - 2	20						
54341 04001	54 - 2	9						
54342 00600	54 - 2	10						
54343 01900	54 - 2	9						
54344 01300	54 - 2	14-1						
54345 00100	54 - 2	13						
54420 06600	54 - 2	14						

Discount Equipment

Discount-Equipment.com is your online resource for commercial and industrial quality parts and equipment sales.

Locations:

Florida (West Palm Beach): [561-964-4949](tel:561-964-4949)

Outside Florida TOLL FREE: [877-690-3101](tel:877-690-3101)

Need parts? Check out our website at www.discount-equipment.com

Can't find what you need?

Click on this link: <http://www.discount-equipment.com/category/5443-parts/> and fill out the request form.

Please have the machine model and serial number available in order to help us get you the correct parts. One of our experienced staff members will get back to you with a quote for the right part that your machine needs.

We sell worldwide for the brands: Genie, Terex, JLG, MultiQuip, Mayco, Toro/Stone, Diamond Products, Magnum, Airman, Mustang, Power Blanket, Nifty Lift, Atlas Copco, Chicago Pneumatic, Allmand Brothers, Essick, Miller Spreader, Skyjack, Lull, Skytrak, Tsurumi, Husquvarna/Target, Whiteman-Concrete/Mortar, Stow-Concrete/Mortar, Baldor, Wacker, Sakai, Snorkel, Upright, Mi-T-M, Sullair, Neal, Basic, Dynapac, MBW, Weber, Bartell, Bennar Newman, Haulotte, Ditch Runner, Blaw-Knox, Himoinsa, Best, Buddy, Crown, Edco, Wyco, Bomag, Laymor, Terremite, Barreto, EZ Trench, Takeuchi, Basic, Bil-Jax, Curtis, Gehl, Heli, Honda, ICS/PowerGrit, Puckett, Waldon, ASV, IHI, Partner, Imer, Clipper, MMD, Koshin, Rice, Gorman Rupp, CH&E, Cat Pumps, Comet, General Pump, Giant, AMida, Coleman, NAC, Gradall, Square Shooter, Kent, Stanley, Tamco, Toku, Hatz, Kohler, Robin, Wisconsin, Northrock, Oztec, Toker TK, Rol-Air, Small Line, Wanco, Yanmar

New Equipment - Used Equipment - Rental Equipment - Parts and Accessories

Discount Equipment

www.discount-equipment.com

561-964-4949

Parts: wbparts@Discount-Equipment.com

Sales: info@Discount-Equipment.com