



OPERATOR MANUAL

MODELS: WolfPac™ 3100
WolfPac™ 3100R (ROPS Option)



ASPHALT ROLLER

A 100% employee-owned American manufacturer

TABLE of CONTENTS

WolfPac™ 3100 / WolfPac™ 3100R

FOREWORD / WARRANTY INFORMATION	4
LIMITED WARRANTY	5
SECTION 1 - TECHNICAL DATA	7 - 9
1.1 Specifications	8 - 9
1.2 Machine Sound Level Test	9
SECTION 2 - HEALTH & SAFETY - Safety Precautions	11 - 16
SECTION 3 - OPERATION	17 - 22
3.1 Introduction and Operating Principle	18
3.2 Fuel and Oil	19
3.2.1 Gasoline Fuel	19
3.2.2 Engine Oil	19
3.2.3 Hydraulic Oil	19
3.3 Before Starting	19 - 20
3.4 To Start	20
3.5 To Operate	20
3.6 Forward/Reverse/Neutral	20
3.7 Throttle	20
3.8 To Stop	20
3.9 Parking Brake	21
3.10 Tie Downs	21
3.11 Hour Meter	21
3.12 Bypass Operation	21
3.13 Drums	21
3.14 Water Tank/Sprinklers	21
3.15 Scrapers	21
3.16 Eccentrics	22
3.17 Asphalt Compaction Tips	22
SECTION 4 - MAINTENANCE	23 - 25
4.1 Maintenance Chart	24
4.2 Roll Over Protective Structures (ROPS)	25
4.2.1 Inspection/Maintenance of ROPS/Seat Belts	25
CALIFORNIA PROPOSITION 65 WARNING	27

Foreword / Warranty Information

These instructions include:

- Safety regulations
- Operating instructions
- Maintenance instructions

These instructions have been prepared for operation on the construction site and for the maintenance engineer.

These instructions are intended to simplify operation of the machine and to avoid malfunctions through improper operation.

Observing the maintenance instructions will increase the reliability and service life of the machine when used on the construction site and reduce repair costs and downtimes.

Always keep these instructions at the place of use of the machine.

Only operate the machine as instructed and follow these instructions.

Observe the safety regulations as well as the guidelines of the civil engineering trade association. Observe the safety rules for the operation of road rollers and compactors and the pertinent regulations for the prevention of accidents.

Stone Construction Equipment, Inc. is not liable for the function of the machine when used in an improper manner and for other than the intended purpose.

Operating errors, improper maintenance and the use of incorrect operating materials are not covered by the warranty.

The above information does not extend the warranty and liability conditions of business of Stone Construction Equipment, Inc.

Warranty Information

Please enter the following data. This will help expedite any service or warranty work.

1. Machine Type: _____

Machine S/N: _____

2. Engine Type: _____

Engine S/N: _____

3. VIN: _____

4. Purchase Date: _____

5. Dealer/Distributor Information:

Name: _____

Address: _____

Phone #: _____

Fax #: _____

6. Battery
Manufacturer: _____

Battery Type: _____

Battery S/N: _____

Location of above information:

1. Information on S/N tag.
2. Information on engine tag.
3. Information on S/N tag - if applicable.
4. Date you purchased machine.
5. Dealer machine was purchased from.
6. Information on battery and battery warranty card.

Stone Construction Equipment, Inc.
P.O. Box 150, Honeoye, New York 14471
Phone: (800) 888-9926
Fax: (585) 229-2363

Limited Warranty

The Manufacturer warrants that products manufactured shall be free from defects in material and workmanship that develop under normal use for a period of 90 days for concrete vibrators and electric pumps, one year for Rhino®, Bulldog®, WolfPac Rollers™, trowels, Stompers®, saws, forward plates, engine powered pumps, Lift Jockey™, Mortar Buggy™ and 6 months for all other products from the date of shipment. The foregoing shall be the exclusive remedy of the buyer and the exclusive liability of the Manufacturer. Our warranty excludes normal replaceable wear items, i.e. gaskets, wear plates, seals, O-rings, V-belts, drive chains, clutches, etc. Any equipment, part or product which is furnished by the Manufacturer but manufactured by another, bears only the warranty given by such other manufacturer. (The Manufacturer extends the warranty period to "Lifetime" for the drum bearings and seals for the mortar mixers, and agrees to furnish, free of charge, the bearings and seals only upon receipt of the defective parts. The warranty is two years for eccentric bearings on the forward plate compactors, mortar and plaster mixer drums, trowel gearboxes and five years on the Bulldog trench roller eccentric bearings.) A Warranty Evaluation Form must accompany all defective parts. Warranty is voided by product abuse, alterations, and use of equipment in applications for which it was not intended, use of non-manufacturer parts, or failure to follow documented service instructions. The foregoing warranty is exclusive of all other warranties whether written or oral, expressed or implied. No warranty of merchantability or fitness for a particular purpose shall apply. The agents, dealer and employees of Manufacturer are not authorized to make modification to this warranty, or additional warranties binding on Manufacturer. Therefore, additional statements, whether oral or written, do not constitute warranty and should not be relied upon.

The Manufacturer's sole responsibility for any breach of the foregoing provision of this contract, with respect to any product or part not conforming to the Warranty or the description herein contained, is at its option (a) to repair, replace or refund such product or parts upon the prepaid return thereof to location designated specifically by the Manufacturer. Product returns not shipped prepaid or on an economical transportation basis will be refused (b) as an alternative to the foregoing modes of settlement - the Manufacturer's dealer to repair defective units with reimbursement for expenses, except labor, and be reviewed with the Manufacturer prior to repair. A Warranty Evaluation Form must accompany all warranty claims.

Except as set forth hereinabove and without limitation of the above, there are no warranties or other affirmations which extends beyond the description of the products and the fact hereof, or as to operational efficiency, product reliability or maintainability or compatibility with products furnished by others. In no event whether as a result of breach of contract or warranty or alleged negligence, shall the Manufacturer be liable for special or consequential damages including but not limited to: Loss of profits or revenues, loss of use of the product or any associated product, cost of capital, cost of substitute products, facilities or services or claims of customers.

No claim will be allowed for products lost or damaged in transit. Such claims should be filed with the carrier within fifteen days.

Effective September 2001.



Stone Construction Equipment, Inc. Phone: 1-800-888-9926 • 1-585-229-5141
8662 Main Street, P.O. Box 150 Fax: 1-585-229-2363
Honeoye, NY 14471-0150 www.stone-equip.com • e-mail: sceny@mcimail.com

1. TECHNICAL DATA

1. TECHNICAL DATA

WolfPac™ 3100 / WolfPac™ 3100R



1.1 - Stone WolfPac 3100 - Specifications

MODEL	STONE WolfPac 3100	STONE WolfPac 3100R
Dimensions		
Dry Wt.	2240 lbs. / 1018 kg.	2515 lbs. / 1140 kg.
Operating Wt.	2890 lbs. / 1314 kg.	3082 lbs. / 1398 kg.
Ballasted Wt.	3100 lbs. / 1409 kg.	3292 lbs. / 1493 kg.
L x W x H	84 x 36 x 56 (in.) / 213 x 91 x 142 (cm.)	84 x 36 x 94 (in.) / 213 x 91 x 239 (cm.)
Drum Width	35.4 in. / 90 cm.	35.4 in. / 90 cm.
Drum Diameter	22 in. / 56 cm.	22 in. / 56 cm.
Side Wall Clearance	1.8 in. / 4.6 cm.	1.8 in. / 4.6 cm.
Curb Clearance	16 in. / 41 cm.	16 in. / 41 cm.
Front /Rear Wall Clearance	3 in. / 9 in. -- 8 cm. / 23 cm.	3 in. / 9 in. -- 8 cm. / 23 cm.
Operating System		
Engine	18 hp / 13.4 kW Honda Twin	18 hp / 13.4 kW Honda Twin
Fuel Capacity	8 gallons / 30.3 liters	8 gallons / 30.3 liters
Drive	Hydrostatic Dual Drum	Hydrostatic Dual Drum
Steering	CP Articulating Hydrostatic	CP Articulating Hydrostatic
Water Tank Capacity	40 gallons - 151 liters	40 gallons - 151 liters
Performance		
Vibrating Drum	Front	Front
Centrifugal Force	3000 lbs. / 1364 kg.	3000 lbs. / 1364 kg.
Frequency	3900 vpm	3900 vpm
Gradeability	30%	30%
Outside Turning Radius	In - 6.6 ft. Out - 9.5 ft. / In - 2 m. Out - 2.9 m.	In - 6.6 ft. Out - 9.5 ft. / In - 2 m. Out - 2.9 m.
Infinitely Variable Speed	0 - 5.0 mph / 0 - 8 km/h	0 - 5.0 mph / 0 - 8 km/h
Standards	Hour Meter, Ignition Switch, Safety Neutral Switch, Transport Link, Lifting Points, Anti-Vandal Prot., 2 Scrapers per drum, Adj. Sliding Seat, Hydraulic Seat, Hydraulic Transmission By-Pass, Hydraulic Press Test Points	Hour Meter, Ignition Switch, Safety Neutral Switch, Transport Link, Lifting Points, Anti-Vandal Prot., 2 Scrapers per drum, Adj. Sliding Seat, Hydraulic Seat, Hydraulic Transmission By-Pass, Hydraulic Press Test Points

1. TECHNICAL DATA

Specifications/
Machine Sound Level Test

1.1 SPECIFICATIONS Continued

BRAKES: SERVICE PARKING	hydrostatic manual operation friction
RECOMMENDED FUEL	gasoline 86 octane min.
ELECTRIC	12 volt system battery BCI group 70 550 cca 25 amp charge system
HYDRAULIC OIL	Mobilfluid 424 (VI-152) SUS225 55CST ISO VG55 capacity 12 gallons /45.4 liters
ECCENTRIC OIL	Mobil Delvac 1230 30W, 12 ounces (.36 liters)
ENGINE OIL	Mobil Delvac 1200 10W30, approximately 1.3 quart/1.2 liters (check engine manual)
SPARK PLUGS	NGK BPR6ES, NIPPONDENSO W20EPR-U gap .028-.031 inches (.70-.80 mm)
GREASE FITTINGS	Mobilgrease XHP222 (NLGI 2EP Lithium Complex)
BATTERY	12 Volt – Standard duty battery BCI group 70 – 550CCA

1.2 MACHINE SOUND LEVEL TEST

Machine Type:	WP3100
Sound Level Meter Calibration Date:	December 19, 1995
Meter Type:	Simpson Model 886-2 Type 2
Test Date:	December 19, 1995
Test Conditions:	
Temperature:	60 degrees Fahrenheit
Ambient Sound:	60 dba slow mode
Soil Condition:	Silts and clays
Engine Speed:	3400 rpm
Frequency:	3900 rpm
Test Site:	Honeoye, New York USA
Sound Level at Operator Position:	88 dba 92 dba with vibe

2. HEALTH & SAFETY

2. HEALTH & SAFETY

Safety Precautions

Before using this equipment, study this entire manual to become familiar with its operation. Do not allow untrained or unauthorized personnel, especially children, to operate this equipment. Use only factory authorized parts for service.

When warning decals are destroyed or missing, contact the Manufacturer immediately at 1-800-888-9926 for replacement. For the safety of yourself and others, it is imperative that the following rules are observed. Failure to do so may result in serious injury or death.

FOLLOW SAFETY INSTRUCTIONS

Carefully read all safety messages and decals in this manual and on your machine safety signs. Keep decals in good condition. Replace missing or damaged decals. Be sure new equipment components and repair parts include the current safety signs. Replacement safety signs and decals are available through your dealer.

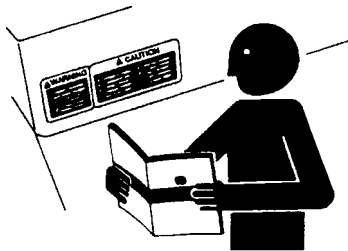

Learn how to operate the machine and how to use controls properly. Do not let anyone operate without instruction.

Keep your machine in proper working condition. Unauthorized modifications to the machine may impair the function and/or safety and affect machine life.

If you do not understand any part of this manual and need assistance, contact your dealer.

▲ DANGER

▲ WARNING

▲ CAUTION

UNDERSTAND SIGNAL WORDS

A signal word – DANGER, WARNING, or CAUTION – is used with the safety-alert symbol. DANGER identifies the most serious hazards.

DANGER or WARNING safety signs are located near specific hazards. General precautions are listed on CAUTION safety signs. CAUTION also calls attention to safety messages in this manual.



This notation appears before warnings in the text. It means that the step which follows must be carried out to avoid the possibility of personal injury or death. These warnings are intended to help the technician avoid any potential hazards encountered in the normal service procedures. We strongly recommend that the reader takes advantage of the information provided to prevent personal injury or injury to others.

2. HEALTH & SAFETY

Safety Precautions



USE COMMON SENSE WHEN HANDLING FUELS

- Transport and handle fuel only when contained in approved safety container.
- Do not smoke when refueling or during any other fuel handling operation.
- Do not refuel while the engine is running or while it is still hot.
- If fuel is spilled during refueling, wipe it off from the engine immediately and discard the rag in a safe place.
- Do not operate the equipment if fuel or oil leaks exist - repair immediately.
- Never operate this equipment in an explosive atmosphere.



- Operator must always be seated when roller is running.
- Never allow more than one person on roller.
- Always turn engine off before dismounting from roller.
- Always apply parking brake when not in use.
- Never park roller on a hill.
- Never operate roller on slope greater than 15 degrees.
- Do not operate the roller in standing water.



- Ear protection required when operating this equipment.
- Exposure to loud noise can cause impairment or loss of hearing.



HOT SURFACES

- Muffler, engine, and engine shroud may be hot.
- Allow all components in the engine compartment to cool before performing any service work.



- Never operate unit in a poorly ventilated or enclosed area.
- Avoid prolonged breathing of exhaust gases.
- Engine exhaust fumes can cause sickness or death.

2. HEALTH & SAFETY

Safety Precautions



- Qualified personnel only. No untrained operators. Serious injury may occur.
- Users must be trained to operate this roller. Read the Operator's Manual and Engine Owner's Manual. Learn to operate this roller safely.
- Do not articulate on grades larger than 15°, roller may tip over.
- Do not operate across the sides of hills, roller may tip over.
- Do not operate at the edge of mats or roads, roller may tip over.
- Do not stand, be seated when roller is running.
- Do not park the roller on hills.
- Always turn off engine and apply brake before dismounting.



- Hydraulic system produces high pressures--incorrect hose replacement can cause serious personal injury. When performing service, refer to Operator's Manual for hose identification and connections.

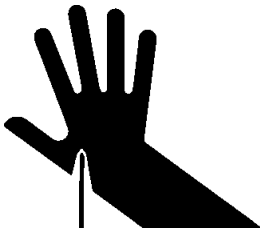

- Caution: Escaping hydraulic fluid under pressure can have sufficient force to penetrate the skin, causing serious personal injury.
- Hydraulic fluid escaping under pressure from a very small hole can be almost invisible. Use a piece of cardboard or wood to search for possible leaks.
- Never use your hands to detect pressure leaks.
- Hydraulic tank temperature can reach 180° F maximum.



- Pressurized release of fluids from hydraulic system can cause serious burns.
- Shut off engine. Only remove filler cap when cool enough to touch with bare hands. Slowly loosen cap to first stop to relieve pressure before removing completely.

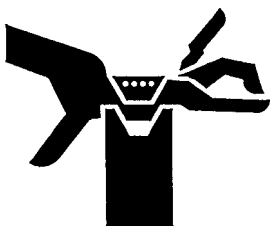

- Never perform any work on the roller while it is running. Before working on the roller, stop the engine and disconnect the spark plug wire(s) to prevent accidental starting, block drums to prevent rolling.
- Keep engine cover closed during the operation.
- Keep hands, clothing and jewelry away from all moving parts.
- Keep all guards in place.

2. HEALTH & SAFETY

Safety Precautions

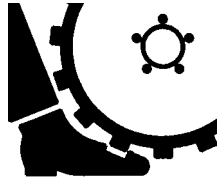

- Keep feet clear of all drums.
- Keep work area free of bystanders.
- For foot protection, wear steel toe shoes or toe pads.

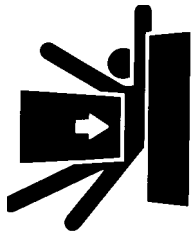

- Caution: Keep away from the machine's articulation area when the engine is running.
- Only start engine from operator's seat.
- Before starting machine, make sure that there are no persons or obstacles near or under machine.

PRACTICE SAFE MAINTENANCE



- Understand service procedure before doing work. Keep area clean and dry.
- Never lubricate, service or adjust machine while it is moving. Keep hands, feet, and clothing from power-driven parts. Disengage all power and operate controls to relieve pressure. Lower equipment to the ground. Stop the engine. Remove the key. Allow machine to cool.
- Securely support any machine elements that must be raised for service work.
- Keep all parts in good condition and properly installed. Fix damage immediately. Replace worn or broken parts. Remove any buildup of grease, oil, or debris.
- Disconnect battery ground cable (-) before making adjustments on electrical systems or welding on machine.

PREPARE FOR EMERGENCIES

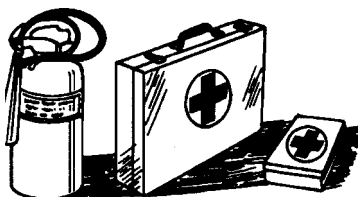

- Be prepared if a fire starts.
- Keep a first aid kit and fire extinguisher handy.
- Keep emergency numbers for doctors, ambulance service, hospital, and fire department near your telephone.

2. HEALTH & SAFETY

Safety Precautions



- Starting fluid (ether) is highly flammable, do not use or an explosion or fire may result.

WEAR PROTECTIVE CLOTHING

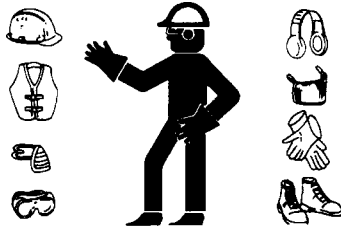

- Wear close fitting clothing and safety equipment appropriate to the job.
- Prolonged exposure to loud noise can cause impairment or loss of hearing.
- Wear a suitable hearing protective device such as earmuffs or earplugs to protect against objectionable or uncomfortable loud noises.
- Operating equipment safely requires the full attention of the operator. Do not wear radio or music headphones while operating machine.



PREVENT BYPASS STARTING

- Avoid possible injury or death from engine runaway.
- Do not start engine by shorting across starter terminal. Engine will start with PTO engaged if normal circuitry is bypassed.
- Start engine only from operator's station with PTO disengaged or in neutral.

DISPOSE OF WASTE PROPERLY

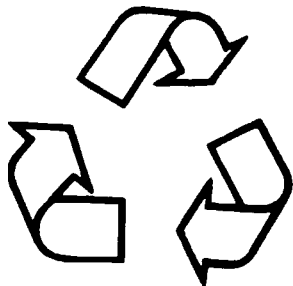

- Improperly disposing of waste can threaten the environment and ecology. Potentially harmful waste used with equipment include such items as oil, fuel, coolant, brake fluid, filters, and batteries.
- Use leakproof containers when draining fluids. Do not use food or beverage containers that may mislead someone into drinking from them.
- Do not pour waste onto the ground, down a drain, or into any water source.
- Air conditioning refrigerants escaping into the air can damage the Earth's atmosphere. Government regulations may require a certified air conditioning service center to recover and recycle used air conditioning refrigerants.
- Inquire on the proper way to recycle or dispose of waste from your local environmental or recycling center.

3. OPERATION

3. OPERATION

WolfPac™ 3100 / WolfPac™ 3100R

3.1 INTRODUCTION & OPERATING PRINCIPLE

Congratulations on your purchase of the WolfPac3100 / WolfPac3100R! You've made an excellent choice! The WolfPac3100 is ergonomically engineered to optimize operator interface with the total machine--it's really "user friendly". Besides good visibility to the roll-edge as well as the work surface, you'll find that the controls are exactly in the right places for maximum comfort. And, it's real convenient to monitor all the consumables--gas, hydraulic oil and water level.

Our common sense approach to servicing is a valuable benefit on the WP3100. Thanks to our modular design, everything that needs servicing is located behind one of the easy-access service panels.

For maneuverability and productivity, nothing beats the proven performance of center-point articulation. Because both drums track each other exactly, it's the best system in the world for rolling close to curbs, curves, in cul-de-sacs and more, with less scuffing and mat tearing.

There's power steering--a feature no operator wants to be without. A variable hydrostatic drive system provides infinitely variable speed control--from 0 to 5 m.p.h.. The eccentric delivers a centrifugal force sufficient to compact all types of soil. Superior vibration isolation to the operator is achieved by mounting heavy-duty shock mounts between the eccentric and support frames.

A 40-gallon polyethylene water tank provides longer running time between refills. A water level sight gauge can be monitored. The low maintenance, gravity flow sprinkler system features dual controls and noncorrosive sprinkler bars, with easy clean-out end caps. For spreading the water and cleaning the drums, there's four urethane scrapers, rubber mounted for easy cleaning.

Upon receipt of your roller, carefully check for any freight damage. Any damage should be immediately reported to the carrier and a claim registered.

The roller is manufactured to the strictest specifications and inspection procedures. If any material or manufacturing defects are found, return the tag on the machine with assembler's signature and your findings to the manufacturer. We want to know when a product is less than perfect. We also welcome any and all input on how the product may serve you better.

The following instructions were compiled to provide you information on how to obtain long and trouble free use of the roller. Periodic maintenance of the roller is essential. Read the manual in its entirety and follow the instructions carefully. Failure to do so may injure yourself or a bystander.

3. OPERATION

WolfPac™ 3100 / WolfPac™ 3100R

3.2 FUEL & OIL

3.2.1 Gasoline Fuel

Always use fresh, unleaded gasoline (86 octane min.). Fresh gasoline is blended for the season and reduces gum deposits which could clog the fuel system. Do not use gasoline left over from the previous season.

Refer to the Engine Manual for break-in.

DO NOT MIX OIL WITH FUEL. The engine has a separate oil reservoir in the crankcase. Unleaded gasoline is recommended for use in the engine since it leaves less combustion chamber deposits.

WARNING

FUEL IS BOTH TOXIC AND FLAMMABLE. DO NOT SMOKE WHILE WORKING WITH FUEL. DO NOT USE NEAR OPEN FLAME. ALWAYS STOP ENGINE BEFORE REFUELING. CLEAN UP SPILLED FUEL BEFORE STARING. AVOID FIRES BY KEEPING ENGINE CLEAN OF ACCUMULATED GREASE AND DEBRIS. START, STORE AND REFUEL ON LEVEL GROUND TO PREVENT PERSONAL INJURY. DO NOT RUN UNIT IN AN ENCLOSED, NON-VENTILATED AREA. AVOID PROLONGED BREATHING OF VAPORS AND SKIN CONTACT. SERIOUS ILLNESS OR LOSS OF LIFE COULD RESULT.

Keep the vent hole in fuel tank cap open. If vent hole is plugged, pressure may build up in tank, causing carburetor flooding or dangerous spraying of gasoline when tank cap is removed. A vacuum may also be created during operation which could stop fuel flow.

3.2.2 Engine Oil

Check for proper oil level. **DO NOT OVERFILL.**

WARNING

ENGINE IS EQUIPPED WITH LOW OIL SHUT-DOWN. ROLLER WILL SHUT DOWN IF ENGINE OIL IS LOW.

3.2.3 Hydraulic Oil

Check the hydraulic fluid level. Use the sight gage located on the hydraulic tank.

A 1/4-1/2" air bubble will be seen at the top of the gauge showing the fluid level.

For satisfactory operation, the following fluid conditions apply:

- Accurate level readings can be checked only when the fluid is cold.
- If the natural color of the fluid has become black or milky, it is possible that an overheating or water contaminant problem exists.
- Do not mix hydraulic fluids.

CAUTION: After a new unit has run 5 hours, the oil filter should be changed. This is to rid the system of any trapped contamination from the wear-in of the parts, see Maintenance.

WARNING

MAKE CERTAIN THAT TRANSMISSION PUMP BYPASS VALVE IS IN RUN POSITION BEFORE STARTING.

NEVER RUN THE ROLLER WITHOUT THE PANELS IN PLACE OR SEVERE PERSONAL INJURY MAY OCCUR.

3.3 BEFORE STARTING

- Check engine oil for proper level.
- Check air cleaner.

3. OPERATION

WolfPac™ 3100 / WolfPac™ 3100R

- Check the fuel level.
- Check the hydraulic fluid level. Use the sight gauge located on the hydraulic tank. A 1/4-1/2" air bubble will be seen at the top of the gauge showing the fluid level.
- Check throttle, levers and controls for smooth operation.

3.4 TO START

- Operator must always be seated when roller is running.
- Move forward/reverse lever into neutral position and apply brake.
- Turn eccentric switch off.
- Set throttle at 1/2 speed.
- Apply choke.
- Turn key clockwise until the engine cranks over. Release the key when the engine starts. DO NOT crank engine for more than five seconds at a time.
- Follow Manufacturer's break-in procedure on engine. Always allow engine to warm up five minutes before applying load.

3.5 TO OPERATE

Disengage the parking brake with caution, apply full throttle and move forward/reverse lever slowly forward to gain speed desired. The same procedure is for reverse. To slow down move forward/reverse lever towards neutral.

To gain power or speed move the forward/reverse lever slightly off neutral. This will produce the greatest amount of torque. Moving the lever all the way

forward or reverse will give the greatest amount of speed.

WARNING

NEVER OPERATE ON SLOPES GREATER THAN 15 DEGREES OR TIPPING MAY OCCUR, RESULTING IN PERSONAL INJURY.

3.6 FORWARD/REVERSE/NEUTRAL

The forward/reverse lever should be aligned with "NEUTRAL" on the console when the roller is not moving forward or backward with the engine running. The neutral interlock switch should not allow the engine to start unless forward/reverse lever is in neutral.

3.7 THROTTLE

The throttle control lever must be tight and it should operate smoothly with light hand pressure (10 lbs. approximately). For best performance, run engine at full throttle.

3.8 TO STOP

WARNING

ALWAYS OBEY THE FOLLOWING PROCEDURES BEFORE DISMOUNTING FROM THE ROLLER.

- Place the forward/reverse lever in the neutral position. Throttle engine down to its slowest speed.
- Apply the parking brake.
- Turn the key to STOP or OFF position. DO NOT CHOKE THE CARBURETOR TO STOP ENGINE.

3. OPERATION

WolfPac™ 3100 / WolfPac™ 3100R

3.9 PARKING BRAKE

Parking brake only, use the forward/reverse lever to slow down roller.

WARNING

ALWAYS APPLY PARKING BRAKE WHEN ROLLER IS NOT IN USE. BLOCK THE DRUMS TO PREVENT ROLLING OF THE MACHINE OR SEVERE PERSONAL INJURY MAY OCCUR. NEVER PARK A ROLLER ON A HILL.

It should take a force of 25-35 pounds, applied at the end of the brake lever, to apply the brake lever. The brake should prevent the roller from moving when applied. Turn knob on brake lever to adjust. Clockwise will increase the force, counterclockwise will decrease it.

3.10 TIE DOWNS

Equipment is equipped with front and rear tie down rings for shipping purposes. Use only these tie downs to secure unit.

WARNING

TIE DOWNS ARE NOT INTENDED FOR LIFTING PURPOSES.

3.11 HOUR METER

The hour meter records the hours of operation and is used to determine when periodic maintenance is required. Record hours and dates of service on Service Record Chart.

WARNING

AVOID LEAVING THE KEY ON WHEN MACHINE IS NOT RUNNING. THIS WILL HAVE AN EFFECT ON THE HOUR METER READINGS.

NEVER PUSH OR PULL THE ROLLER. THE ROLLER IS EQUIPPED WITH A BYPASS VALVE.

3.12 BYPASS OPERATION

In an emergency or during a breakdown, it may be necessary or desirable to tow the roller. The bypass valve is located on the pump under the hood. By turning the valve to bypass, the roller may be moved short distances at LOW speed without running the engine.

WARNING

STAND WELL CLEAR OF THE DRUMS WHEN THE BYPASS LEVER IS ACTUATED. NEVER ALLOW UNTRAINED PERSONNEL TO OPERATE THE VALVE. SEVERE PERSONAL INJURY OR INJURY TO OTHERS MAY RESULT.

3.13 DRUMS

The rear drum can be filled with water. There are two plugs. One plug to fill with water and the other to drain. Drain water from drum if temperature is expected to drop to 32 degrees Fahrenheit (0 degrees Celsius).

3.14 WATER TANK/SPRINKLERS

Fill the tank with clean water. The water tank holds 40 US gallons. Dirty water will clog the sprinkler bars. The roller is equipped with front and rear sprinklers. To turn on sprinklers, turn the sprinklers knobs clockwise. Water flow is adjustable by varying the knob position. If the water tank is subject to freezing temperatures, all the water lines and the water tank must be drained by draining through sprinkler tubes.

3.15 SCRAPERS

Scrapers, located on the front and rear of both drums, must make uniform contact across entire width of drum to ensure even application of water from the sprinkler system. Also, scrapers prevent dirt and asphalt from collecting.

3. OPERATION

WolfPac™ 3100 / WolfPac™ 3100R

3.16 ECCENTRICS

When vibratory compaction is necessary, engage eccentrics by pushing the vibration switch to the ON position. For best performance, run engine at full RPM. The eccentrics should be turned off whenever the roller is stopped, or stopped to change direction. Do not run the eccentric on any non-yielding surface, such as concrete or aged asphalt.

3.17 ASPHALT COMPACTION TIPS

- Make sure drums are coated with just enough water to prevent asphalt sticking to the drums.
- Two passes should be sufficient if the asphalt temperature is about 285 degrees F or greater.
- Do not let asphalt stand for an extended time before rolling.
- As soon as the asphalt will support roller without shoving or causing excessive movement of the mat, the operator may proceed with the breakdown pass. If the mat shows cracks or splits perpendicular to the roller path, let mix cool 3 to 5 minutes before continuing.
- Whenever possible, back roller towards paver so that static drive roll proceeds the vibrating front roll.
- Always stop vibratory unit before roller comes to a standstill to avoid ridging the mat.
- Change directions and speed slowly to avoid tearing the mat.
- Reduce engine RPM if vibratory roll "bounces" or is "erratic" to avoid over compacting the asphalt and damaging the unit.

- To assist edge compaction and confinement, leave 4" uncompacted and allow to cool slightly before finishing.
- When possible, begin breakdown pass downhill and return uphill on same pass before moving over to next pass.
- Compact on low edge first making breakdown pass and immediately reversing on breakdown pass before moving toward high edge of the second pass.
- On cool, thick, or coarse mats, make as many intermediate and finish passes as necessary to achieve desired compaction and surface finish but avoid over-compaction (aggregate fracturing).
- A general guideline for maximum lift:
Dirt: 6"
Asphalt: 3"

Avoid sharp turns, steer gradually. If articulation is a new concept, we suggest the operator to take 20 minutes or so to get used to the feel of the unit.

Recommended asphalt rolling should be at 3 m.p.h. or less to achieve a uniform mat. Slow the paver down rather than speed up the roller.

NOTE: Depressions in the mat will occur if the roller is left standing on it. When roller needs to be stopped for refueling, maintenance, etc. remove from fresh asphalt.

4. MAINTENANCE

4. MAINTENANCE

WolfPac™ 3100 / WolfPac™ 3100R

4.1 MAINTENANCE CHART

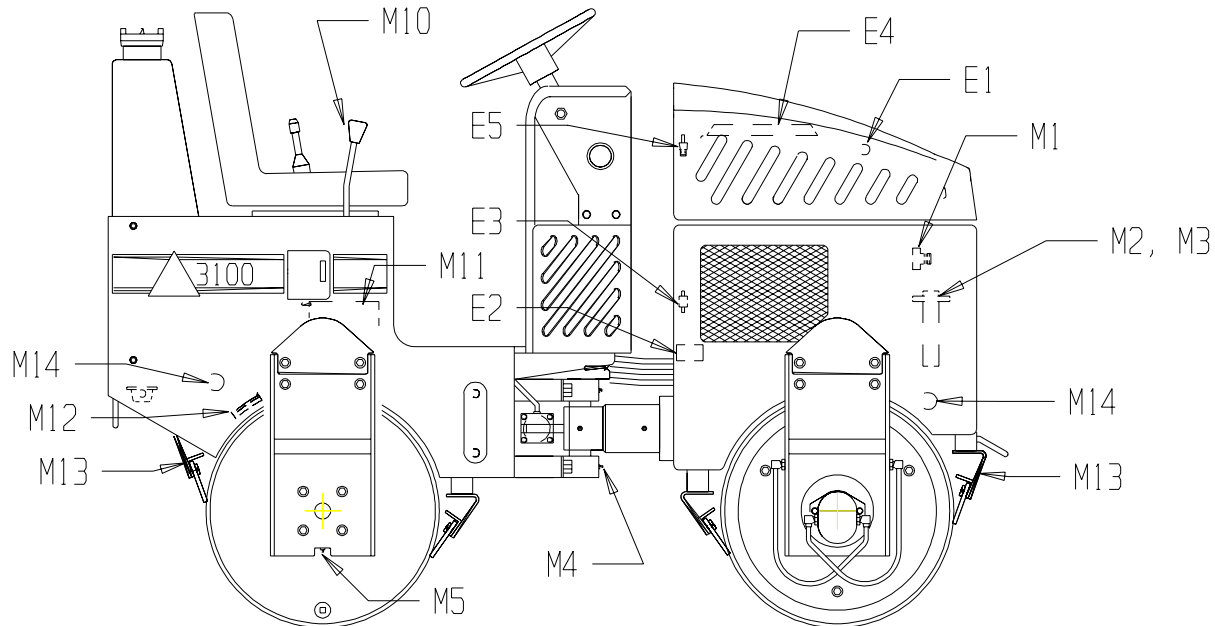

✓ CHECK/ADJUST ○ CLEAN/REPLACE	DAILY	WEEKLY	OTHER	INSTRUCTIONS
ENGINE #				READ EMISSION WARRANTY, OPERATING & ENGINE OWNER'S MANUAL
E1 OIL LEVEL	✓		○	REPLACE AT 20 HRS, THEN EVERY 100 HRS SAE 10W-30 SH DR SJ
E2 OIL FILTER			○	REPLACE EVERY 200 HRS P/N 31230
E3 A. IN-LINE FUEL FILTER			○	CHECK EVERY 100 HRS REPLACE EVERY 300 HRS P/N 38856
E3 B. HONDA FUEL FILTER			○	REPLACE EVERY 300 HRS P/N 31231
E4 A. PRECLEANER	✓		○	CLEAN EVERY 50 HRS REPLACE EVERY 300 HRS P/N 31335
E4 B. AIR FILTER	✓		○	CLEAN EVERY 50 HRS REPLACE EVERY 300 HRS P/N 31336
E5 SPARK PLUGS			○	CLEAN, GAP .028 EVERY 100 HRS REPLACE EVERY 300 HRS P/N 31234
E6 ENGINE RPM #			✓	CHECK IDLE & FULL SPEED RPM EVERY 300 HRS
E7 COOLING SYSTEM		✓	○	CLEAN/BLOW OUT AIR INLETS, ENGINE FINS & DUCTING
E8 VALVE CLEARANCE ##			✓	CHECK/ADJUST EVERY 300 HRS
MACHINE				IMPORTANT READ OPERATING MANUAL & ENGINE OWNER'S MANUAL
M1 HYDRAULIC OIL LEVEL	✓		○	REPLACE EVERY 800 HRS MOBIL 424
M2 HYDRAULIC FILTER			○	REPLACE EVERY 100 HRS P/N 39740
M3 HYDRAULIC BREATHER			○	REPLACE EVERY 800 HRS P/N 39741
M4 PIVOT (4 PLACES)			○	LUBE WEEKLY WITH LITHIUM BASE GREASE
M5 RIGHT REAR BEARING			○	LUBE WEEKLY WITH LITHIUM BASE GREASE
M6 ECCENTRIC OIL			○	CHANGE EVERY 500 HOURS SAE 30
M7 FUEL TANK #			○	FLUSH/CLEAN FUEL TANK EVERY YEAR
M8 FUEL LINES & CLAMPS		✓	○	CHECK WEEKLY/REPLACE EVERY 2 YEARS P/N 46186
M10 CONTROLS	✓			CHECK OPERATION, LIGHTLY OIL CABLES & LEVERS EVERY 200 HRS
M11 BATTERY/CHARGE SYSTEM			○	CHECK & CLEAN MONTHLY/CHECK FOR 13-14 VOLTS AT FULL RPM
M12 PARKING BRAKE	✓			CLEAN UNIT & INSPECT
M13 SCRAPERS/MOUNTS	✓			CLEAN UNIT & INSPECT
M14 SPRINKLERS	✓			CLEAN UNIT & INSPECT
M15 LEAKS OIL & FUEL	✓			CLEAN UNIT & INSPECT
M16 HARDWARE/ENGINE	✓			CLEAN UNIT & INSPECT
# IMPORTANT READ HONDA EMISSION WARRANTY STATEMENT, STONE & ENGINE OWNER'S MANUAL ## SEE AUTHORIZED ENGINE SERVICE DEALER AND/OR REFER TO ENGINE SHOP MANUAL FOR PROCEDURES 55401B				

4. MAINTENANCE

WolfPac™ 3100 / WolfPac™ 3100R

4.2 ROLL OVER PROTECTIVE STRUCTURES (ROPS)

Proper inspection and maintenance procedures can ensure that the ROPS will perform the lifesaving function they are designed for and expected to do. Make regular, periodic inspections to ensure that the ROPS are damage-free and thus capable of functioning in an upset.

Generally ROPS structures are not intended as external load carrying members and must not be used to mount attachments such as pull hooks, winches, side brooms, etc. without the manufacturer's approval.

Modifications to basic design should be avoided as recertification is required.

4.2.1 Inspection/Maintenance of ROPS/Seat Belts

Scheduled, frequent visual checks of mounting hardware by the operator or service personnel are recommended. Inspection with regular service intervals is suggested. During the inspection check for the following:

- Worn, damaged, or missing resilient mounts. Excessive motion or rattling during operation are indications of a problem.
- Loose, missing, or damaged mounting hardware (bolts, nuts, washers, etc.). Bolts should be checked for proper torque.
- Cracks in ROPS structure and mounting system. The machine should be cleaned, as necessary, to allow inspection for cracks in the structure and mounting system. Rust lines should be taken as indications of cracks and verified by inspection. Some cracks will badly affect the ROPS function. If in doubt, consult the manufacturer.
- Corrosion. Extensive paint peeling and rust should be noted and corrective action taken.

- Seat belt. The presence and operability of a seat belt should be noted. The belt should be clean, free of dirt and grease, and the latch should function smoothly. The structure should be inspected following a roll over, collision, or fire.

WARNING

DO NOT REPAIR, MODIFY, OR ADD ATTACHMENTS TO ROPS UNLESS AUTHORIZED IN WRITING BY THE MANUFACTURER.

**CALIFORNIA PROPOSITION 65 WARNING:
Operation of this equipment and/or engine exhaust
from this product contains chemicals known to the
State of California to cause cancer, birth defects,
or other reproductive harm.**



*Bred Tough. Technology Born to Work.
The Way It Ought To Be.*

Stone Construction Equipment, Inc.
P.O. Box 150, Honeoye, New York 14471
Phone: (800) 888-9926
Fax: 585-229-2363
e-mail: sceny@mcimail.com
www: stone-equip.com

A 100% employee-owned American manufacturer

© 1996 Stone Construction Equipment, Inc.
Printed in U.S.A.

GP1M