

AIRMAN

SG

PARTS CATALOG

ENGINE GENERATOR

SDG40S-8B1



www.discount-equipment.com

HOKUETSU INDUSTRIES CO., LTD.

Discount Equipment

Discount-Equipment.com is your online resource for commercial and industrial quality parts and equipment sales.

Locations:

Florida (West Palm Beach): [561-964-4949](tel:561-964-4949)

Outside Florida TOLL FREE: [877-690-3101](tel:877-690-3101)

Need parts? Check out our website at www.discount-equipment.com

Can't find what you need?

Click on this link: <http://www.discount-equipment.com/category/5443-parts/> and fill out the request form.

Please have the machine model and serial number available in order to help us get you the correct parts. One of our experienced staff members will get back to you with a quote for the right part that your machine needs.

We sell worldwide for the brands: Genie, Terex, JLG, MultiQuip, Mayco, Toro/Stone, Diamond Products, Magnum, Airman, Mustang, Power Blanket, Nifty Lift, Atlas Copco, Chicago Pneumatic, Allmand Brothers, Essick, Miller Spreader, Skyjack, Lull, Skytrak, Tsurumi, Husquvarna/Target, Whiteman-Concrete/Mortar, Stow-Concrete/Mortar, Baldor, Wacker, Sakai, Snorkel, Upright, Mi-T-M, Sullair, Neal, Basic, Dynapac, MBW, Weber, Bartell, Bennar Newman, Haulotte, Ditch Runner, Blaw-Knox, Himoina, Best, Buddy, Crown, Edco, Wyco, Bomag, Laymor, Terremite, Barreto, EZ Trench, Takeuchi, Basic, Bil-Jax, Curtis, Gehl, Heli, Honda, ICS/PowerGrit, Puckett, Waldon, ASV, IHI, Partner, Imer, Clipper, MMD, Koshin, Rice, Gorman Rupp, CH&E, Cat Pumps, Comet, General Pump, Giant, AMida, Coleman, NAC, Gradall, Square Shooter, Kent, Stanley, Tamco, Toku, Hatz, Kohler, Robin, Wisconsin, Northrock, Oztec, Toker TK, Rol-Air, Small Line, Wanco, Yanmar

New Equipment - Used Equipment - Rental Equipment - Parts and Accessories

Discount Equipment

www.discount-equipment.com

561-964-4949

Sales: info@Discount-Equipment.com

Parts: wbparts@Discount-Equipment.com

適用型式
FOR MODEL

型式 MODEL	適用号機 SER. NO.
SDG40S-8B1	1328B10051~

原動機型式 ENGINE MODEL	KUBOTA V3300-E3B
Eng. oil filter	KUBOTA 1C020-32433 (北越部番 37438 08800)
Fuel filter	KUBOTA 16631-43562 (北越部番 43534 04900)

NOTICE

1. This parts catalog contains all the parts and assemblies of "AIRMAN" brand products. The complete unit is divided into several parts groups, the details of which are clearly illustrated, and completely listed. So desired part number, name and quantity can be easily determined referring to Ref. No.

2. When you place order for service parts, please be sure to advise us of the following information.

- (1) Part number.
- (2) Quantity required.
- (3) Part name.
- (4) Model name and Serial number.

3. How to read parts catalog.

(1) Ref. No.

Reference number (Ref. No.) is to be used for locating the part number and name from the illustrations. (However some parts such as bolts and nuts etc., are not illustrated but their reference numbers only listed.)

Ref. No. 1, 1-1, 1-2, shows history of part modifications; namely ref. No. 1 changed to No. 1-1 and then 1-2.

Example: Ref. No.	Part No.
1.	21101 00101
1-1.	21101 00103

(2) Part No.

Every part has its own proper number.

Even if a part has the same shape as an other part and if its number different, it is not interchangeable at all in many cases.

(3) Interchangeability

A. B. C. D. Q. X. Y. and Z. in column "Interchangeability" show the following.

A : A new part is replaceable with an old part, but the old part is not replaceable with the new one.

B : Not interchangeable.

C : Disused.

D : Newly added.

Q : Quantity per unit changed.

X : Included in this set of parts, this part is not used for this model.

Y : Part to be selected.

Z : This part can not be supplied as an individual part.

(4) Part name

Every part has its own proper name.

(5) Q'ty

The number shown in the column of Q'TY indicates the quantity of parts used per one unit machine.

(6) Change column

M1,M2,M3,.....Mn mentioned in the column indicate the change of part number. and the serial number of the unit,the part of which was modified.

To check the serial number, refer to "LIST OF MACHINE SERIAL NUMBERS & CHANGED PART NUMBERS" mentioned in the front part of this book.

4. Abbreviations used in this catalog.

ass'y	assembly	L	Length
A	Ampere	OPT.	Option
AUTO.	Automatic	SPC/S.	Special specifications
C/H	Change column	STD.	Standards
Const.	Consisting of	sw.	switch
Cont.	Control	T or t	Thickness
Eng.	Engine	V	Volt
EXP.	Export	W	Watt
GEN.	Generator	w.	with
Incl.	Including	w/o	without

5. HOW TO READ MODELS

Example: S D G 2 5 S - 3 A 1

SDG : SKID-MOUNTED DIESEL GENERATOR

PDG : PORTABLE DIESEL GENERATOR

SPG : SKID-MOUNTED POWER TAKE OFF GENERATOR

ATS : AUTOMATIC TRANSFER SWITCHES

25 : OUTPUT(kVA)

S : SILENT TYPE

w/o S: UNSILENCED TYPE

A S : ADVANCED SILENT TYPE

3 : BOX TYPE

4 : SUPER SLIM TYPE

5 : FREQUENCY

6 : NORTH AMERICA TYPE

7 : w.OIL FENCE

8 : NORTH AMERICA TYPE(w.OIL FENCE)

In case of ATS: 1~4•••12V TYPE,5~8•••24V TYPE

NOTE: We are always engaged in improving our products. So there may be some changes of the product which are not yet mentioned in this parts catalog.

Therefore, in necessary case, we issue a revision in which such changes are added.

When you have any question on the parts catalog, please ask your nearest dealer or directly us.

For engine parts, please refer to separate engine parts catalog.

MODEL CHANGE MARK

No mark: POWER TAKE OFF GENERATOR

VARIATION MARK

No mark: w/o METAL CONSENT

M : w. METAL CONSENT

A : TRIPLE-V(TYPE A)

B : w. METAL CONSENT(TYPE B)

C : w. SAFETY SYSTEM(TYPE C)

E : w. ATS

D : w. OIL FENCE & TRIPLE-V(TYPE A)

F : w. OIL FENCE &

w. SAFETY SYSTEM(TYPE C)

G : w. OIL FENCE & w. ATS

部品番号変更時期一覧表
LIST OF MACHINE SERIAL NUMBERS & CHANGED PART NUMBERS

変更 C/H	型式と実施号機 MODEL NAME & SER. NO. OF THE UNIT, THE PART OF WHICH WAS CHANGED					
	SDG40S-8B1					

Discount-Equipment.com

目 次
CONTENTS

図 番 号 FIG. NO.	図 名 称 FIG. NAME	頁 PAGE
20 - 00	GENERATOR, MOUNTING & INTAKE	ゼネレータ, マウンティング, インテーク 20- 1~2
38 - 00	COOLING, ENGINE & EXHAUST	クーリング, エンジン, エキゾースト 38- 1~2
39 - 00	NAME PLATE	ネームプレート 39- 1~2
43 - 00	FUEL LINE	フュエルライン 43- 1~2
44 - 00	ELECTRIC	エレクトリック 44- 1~3
51 - 00	FRAME & BONNET	フレーム, ボンネット 51- 1~2
51 - 01	OIL FENCE	オイルフェンス 51- 3~4
52 - 00	LINING	ライニング 52- 1

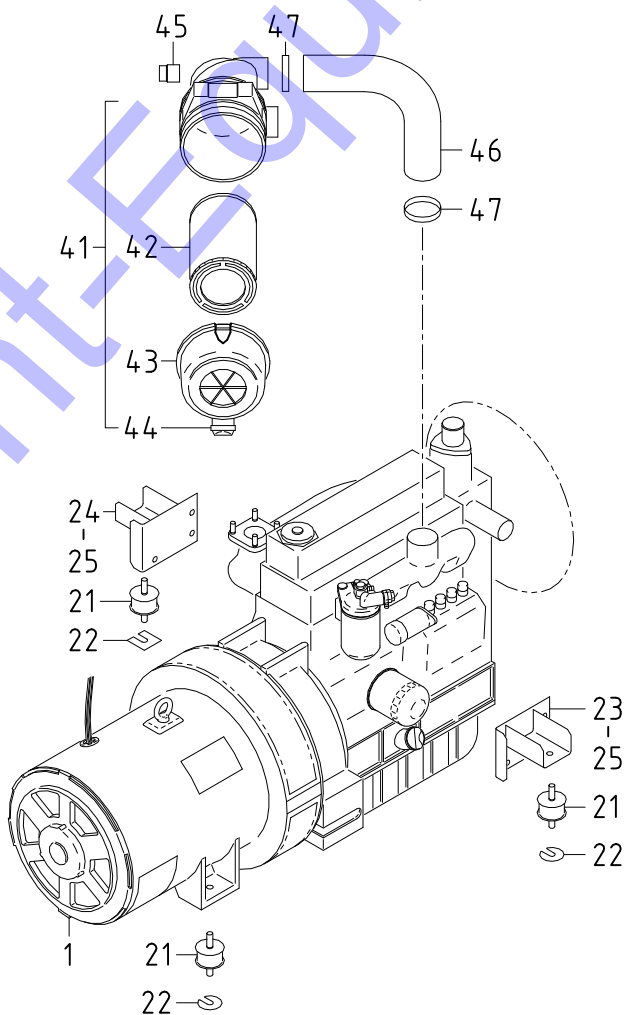
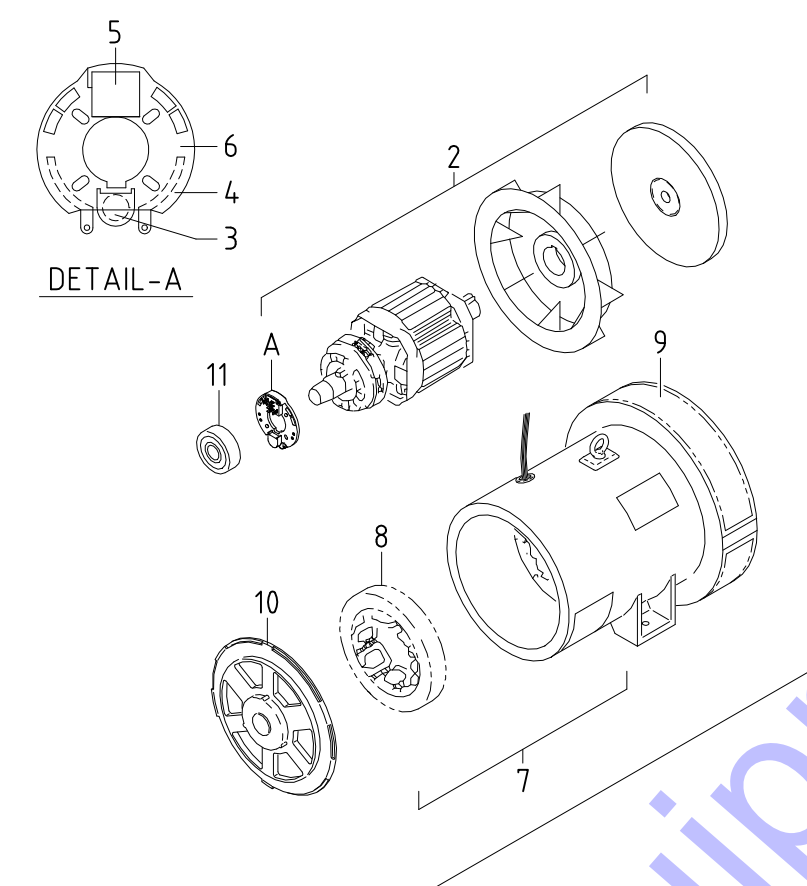

20 - 00 GENERATOR, MOUNTING & INTAKE

Ref. NO.	Part NO.	Inter-change ability	Part Name	Q'ty	C/H	Remarks	Ref. NO.	Part NO.	Inter-change ability	Part Name	Q'ty	C/H	Remarks
20 - 00 GENERATOR GROUP													
1	20003 57603		Generator	1		Const. No. 2~11							
	02135 10040		Bolt	8		(for coupling)							
	03115 02010		Spring washer	8		(for coupling)							
	02238 10030		Bolt, w/w	11		(for casing)							
2	25100 09101		A. C. G. rotor ass'y	1		Incl. No. 3~6							
3	25650 01800		Surge absorber	1									
4	25651 00300		Plate	1									
5	46921 08800		Silicon rectifier	1									
	02345 63012		Screw	2									
	03115 02003		Spring washer	2									
	03116 12003		Plain washer	2									
6	25660 02400		Plate	1									
	02912 08006		Nut	4									
	03115 02006		Spring washer	4									
	03116 12006		Plain washer	4									
7	25200 11100		A. C. G. stator ass'y	1									
8	25700 07600		EX. stator ass'y	1									
	02138 06040		Bolt	3									
	03115 02006		Spring washer	3									
	03116 12006		Plain washer	3									
	02138 10016		Bolt	2									
9	25360 07100		Cover	1									
	02248 06025		Bolt, w/w	1									
10	25310 09600		Casing	1									
	02138 08030		Bolt	4									
	03115 02008		Spring washer	4									
11	21472 15700		Bearing	1		(6308ZZ)							
31 - 00 MOUNTING GROUP													
21	GG160 00100		Vibration isolator ass'y	4									
	02915 20012		Nut, w/w	8									
22	31120 08900		Shim	1									
23	31110 02610		Bracket	1									
24	31110 02710		Bracket	1									
25	02108 12025		Bolt	6									
	03115 02012		Spring washer	6									
32 - 00 INTAKE GROUP													
41	32100 40700		Air filter ass'y	1		Const. No. 42~44							
	02201 08012		Flange bolt	2									
42	32143 11700		Element	1									
43	32142 08600		Cup	1									
44	32151 01400		Vacuator valve	1									
45	32148 03000		Filter, service indicator	1									
46	32331 79000		Hose	1									
47	03511 20080		Hose clip	2									

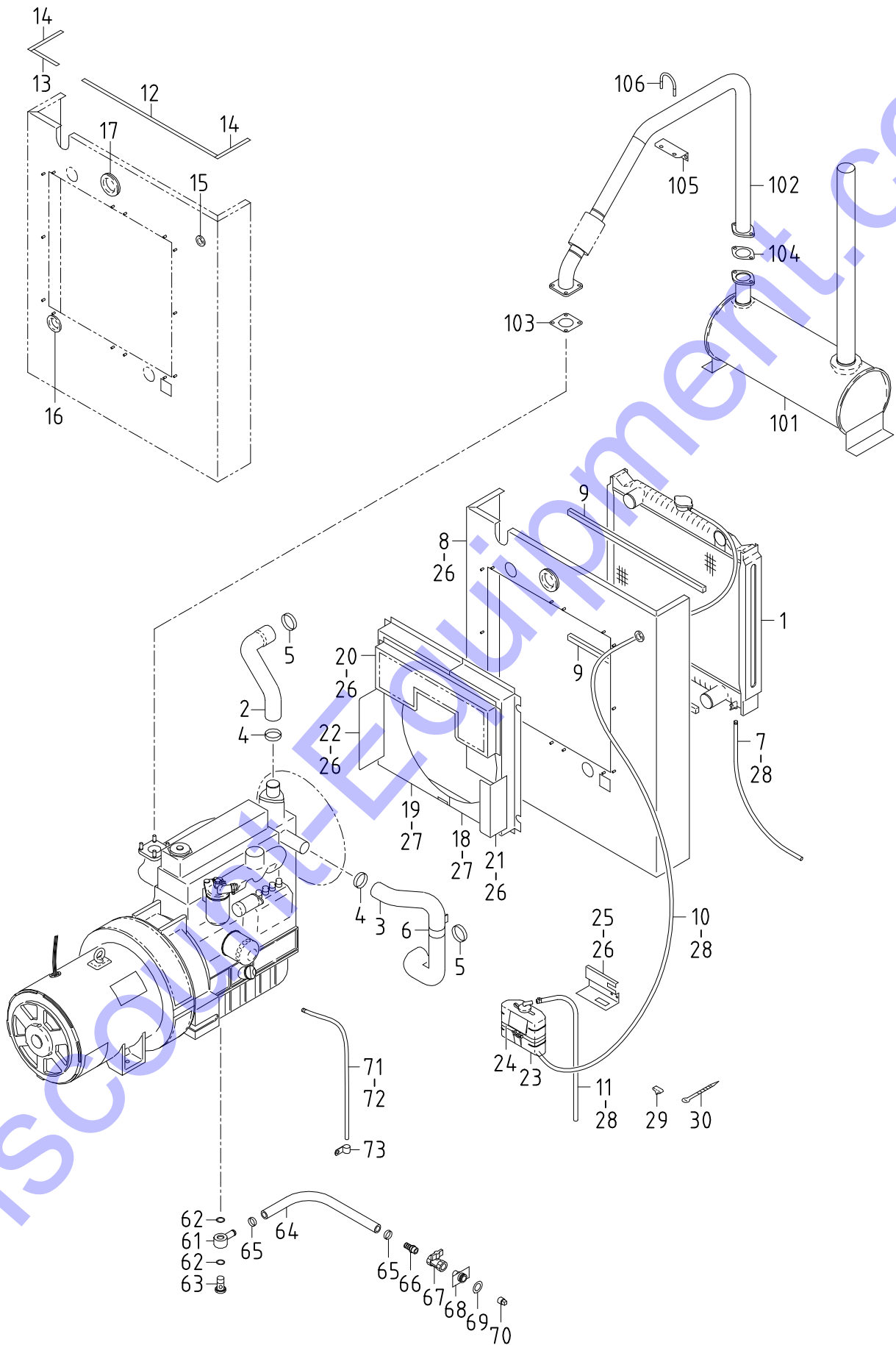

38 - 00 COOLING, ENGINE & EXHAUST

Ref. NO.	Part NO.	Inter-change ability	Part Name	Q' ty	C/H	Remarks	Ref. NO.	Part NO.	Inter-change ability	Part Name	Q' ty	C/H	Remarks
38 - 00 COOLING GROUP													
1	38100 40400		Radiator	1		Incl. Cap & Valve							
	38410 05800		Cap	1									
	38469 01400		Valve	1		(drain)							
	02201 08012		Flange bolt	4									
2	38524 68100		Hose	1									
3	38524 68000		Hose	1									
4	03511 20060		Hose clip	2									
5	03511 20070		Hose clip	2									
6	03424 80218		Clip	1									
	02201 10020		Flange bolt	1									
7	38594 02000		Hose	1		(drain)							
8	52350 70821		Cover	1									
9	03407 67311		Seal rubber	2									
10	38594 03100		Hose	1									
11	38594 05000		Hose	1									
12	03407 66933		Seal rubber	1									
13	03407 66952		Seal rubber	1									
14	03407 66939		Seal rubber	2									
15	03403 00303		Grommet	1									
16	03403 00512		Grommet	1									
17	03403 00703		Grommet	1									
18	38440 02811		Shroud, fan	1									
19	38440 02911		Shroud, fan	1									
20	38450 80501		Guard, fan	1									
21	38450 81001		Guard, fan	1									
22	38450 81100		Guard, fan	1									
23	38590 01200		Reserve tank ass'y	1									
24	03511 30185		Hose clip	1									
25	38591 01000		Bracket	1									
26	02201 06016		Flange bolt	16									
27	02915 00006		Hexagon flange nut	14									
28	03511 40016		Hose clip	4									
29	44243 05500		Holder	4									
30	03425 00001		Vinyl clip	4									
41 - 00 ENGINE GROUP													
61	43534 02102		Ring connector (Nipple)	1									
62	03407 16024		Gasket	2									
63	43532 09400		Nipple (Bolt)	1									
64	03580 19055		Hose	1									
65	03511 20035		Hose clip	2									
66	37170 02900		Joint	1									
67	03735 13004		Valve	1									
68	37170 20100		Joint	1									
	02201 06016		Flange bolt	2									
69	52728 15710		Cushion rubber	1									
70	03620 41004		Plug	1									
71	38594 02900		Hose	1									
72	03511 40016		Hose clip	1									
73	37181 05000		Clip	1									
	02108 12025		Bolt	1									
	03115 02012		Spring washer	1									
	03116 12012		Plain washer	1									
42 - 00 EXHAUST GROUP													
101	42100 79400		Exhaust muffler	1									
	02201 10020		Flange bolt	4									
102	42310 97200		Pipe, exhaust	1									
	02915 11010		Hexagon flange nut	4		(for engine)							
	02136 10035		Bolt	2		(for muffler)							
	02912 06010		Nut	2		(for muffler)							
	03115 06010		Spring washer	2		(for muffler)							
	03116 15010		Plain washer	4		(for muffler)							
103	42324 15200		Gasket	1									
104	42324 13600		Gasket	1									
105	42240 28201		Bracket	1									
	02201 08020		Flange bolt	2									
106	03830 08004		U-bolt	1									
	02915 00008		Hexagon flange nut	2									

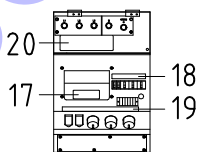
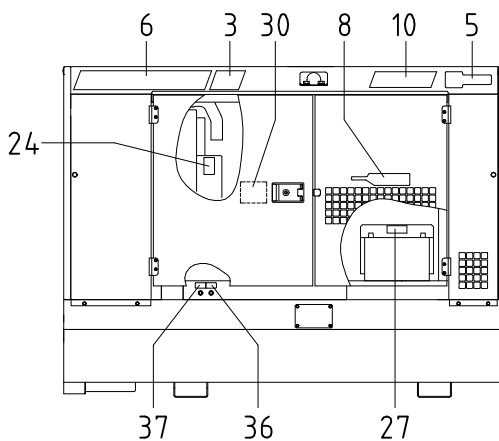
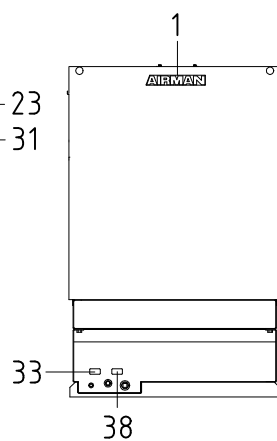
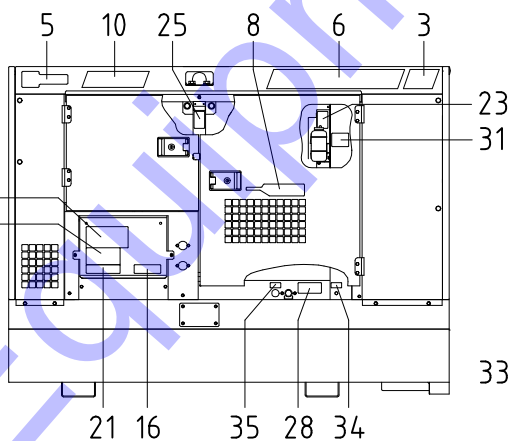
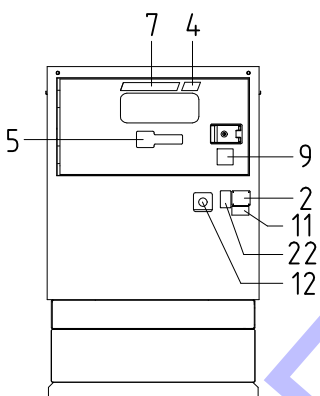
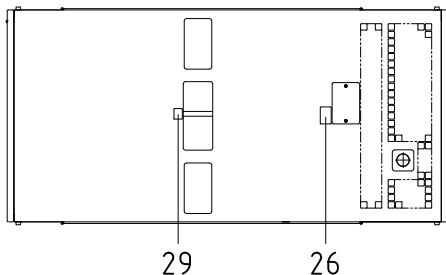
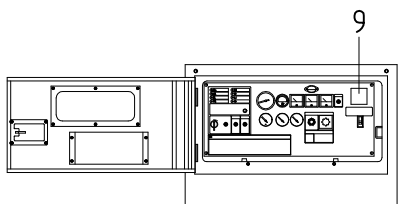

OUTPUT TERMINAL

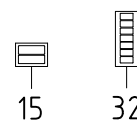

39 - 00 NAME PLATE

Ref. NO.	Part NO.	Inter-change ability	Part Name	Q' ty	C/H	Remarks	Ref. NO.	Part NO.	Inter-change ability	Part Name	Q' ty	C/H	Remarks
	39 - 00		ACCESSORY GROUP										
	39600 14930		Instruction manual										
	39615 08200		Instruction manual (Eng.)										
	39616 05800		Parts catalog (Eng.)										
1	39170 02000		Mark (AIRMAN)	1									
2	39103 46801		Plate (SER. NO.)	1									
	03260 03010		Blind rivet	4									
3	39178 61430		Plate (40)	2									
4	39178 61530		Plate (40)	1									
5	39178 57720		Plate (MMD)	3									
6	39178 54721		Plate (Power Pro)	2									
7	39178 54820		Plate (Power Pro)	1									
8	39178 53620		Plate (QUIETECH)	2									
9	39178 80820		Plate (DELTA DEMAND)	2									
10	39178 63830		Plate (49HP)	2									
11	39178 43110		Plate (california)	1									
12	39178 47610		Plate (emergency sw.)	1									
13	39176 05010		Plate (output)	1									
14	39176 62400		Plate (danger, high voltage)	1									
15	39173 02000		Plate, complete	1		Const. No. 16~17							
16	39176 85800	Z	Plate (terminal in)	1									
17	39176 85900	Z	Plate (terminal in)	1									
18	39178 87210		Plate (breaker)	1									
19	39178 50620		Plate (socket)	1									
20	39152 23401		Plate (wiring chart)	1									
21	39176 62900		Plate (warning, electric shock)	1									
22	39176 73300		Plate (warning, exhaust gases)	1									
23	39176 73500		Plate (warning, cooling fan)	1									
24	39176 73800		Plate (warning, pulley)	1									
25	39176 69500		Plate (caution, high temp.)	1									
26	39176 69600		Plate (caution, radiator cap)	1									
27	39176 50000		Plate (warning, battery)	1									
28	39178 22030		Plate (No fire)	1									
29	39176 69300		Plate (lift position)	1									
30	39178 49120		Plate (changed fuel refill)	1									
31	39178 00310		Plate (LLC)	1									
32	39173 03300		Plate, complete	1		Const. No. 33~38							
33	39189 21300	Z	Plate (fuel drain)	1									
34	39189 21400	Z	Plate (radiator drain)	1									
35	39189 21500	Z	Plate (eng. oil drain)	1									
36	39178 90520	Z	Plate (fuel inlet)	1									
37	39178 90620	Z	Plate (fuel return)	1									
38	39189 21100	Z	Plate (containment drain)	1									

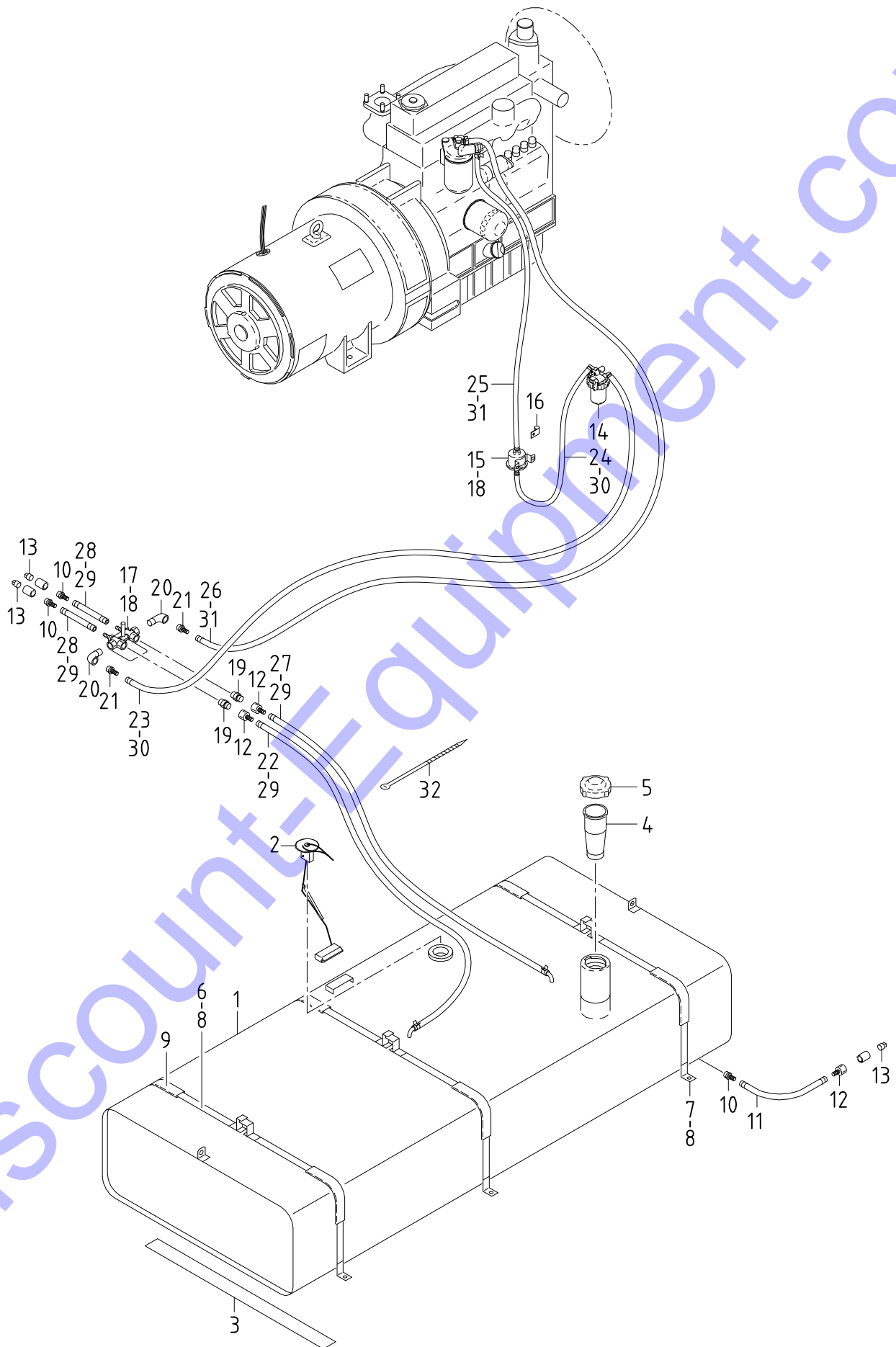

43 - 00 FUEL LINE

Ref. NO.	Part NO.	Inter-change ability	Part Name	Q' ty	C/H	Remarks	Ref. NO.	Part NO.	Inter-change ability	Part Name	Q' ty	C/H	Remarks
	43 - 00		FUEL GROUP										
1	43100 70102		Fuel tank	1									
2	36159 03000		Sending unit	1									
	02415 65012		Screw, w/w	5									
3	38465 12600		Cushion rubber	3									
4	43210 01301		Strainer	1									
5	43220 01300		Cap	1									
6	43310 27200		Belt	3									
7	43310 27300		Belt	3									
	02138 10070		Bolt	3									
	03115 02010		Spring washer	3									
	03116 12010		Plain washer	6									
	02912 08010		Nut	3									
8	02915 00008		Hexagon flange nut	6									
9	43322 06700		Cushion rubber	6									
10	37170 12700		Joint	3									
11	03570 09028		Hose	1									
	03511 20020		Hose clip	2									
12	37170 20200		Joint	3									
13	03620 41003		Plug	3									
14	43550 03100		Sedimenter	1		(KUBOTA RD819-51261)							
	02201 08070		Flange bolt	1									
15	43650 02400		Fuel pump	1		(KUBOTA R1401-51351)							
	02201 08012		Flange bolt	1									
16	37181 07300		Clip	2									
17	35483 10101		Stop valve	1									
18	02201 06016		Flange bolt	3									
19	03734 43030		Nipple	2									
20	03731 21003		Nipple elbow	2									
21	37170 12200		Joint	2									
22	03600 09100		Hose	1									
23	03600 08182		Hose	1									
24	03600 08071		Hose	1									
25	03570 08042		Hose	1									
26	03570 08207		Hose	1									
27	03600 09040		Hose	1									
28	03600 09008		Hose	2									
29	03511 40020		Hose clip	8									
30	03511 40016		Hose clip	4									
31	03511 10017		Hose clip	2		(pump side)							
	03511 20016		Hose clip	2		(Eng. side)							
32	03425 00003		Vinyl clip	15									

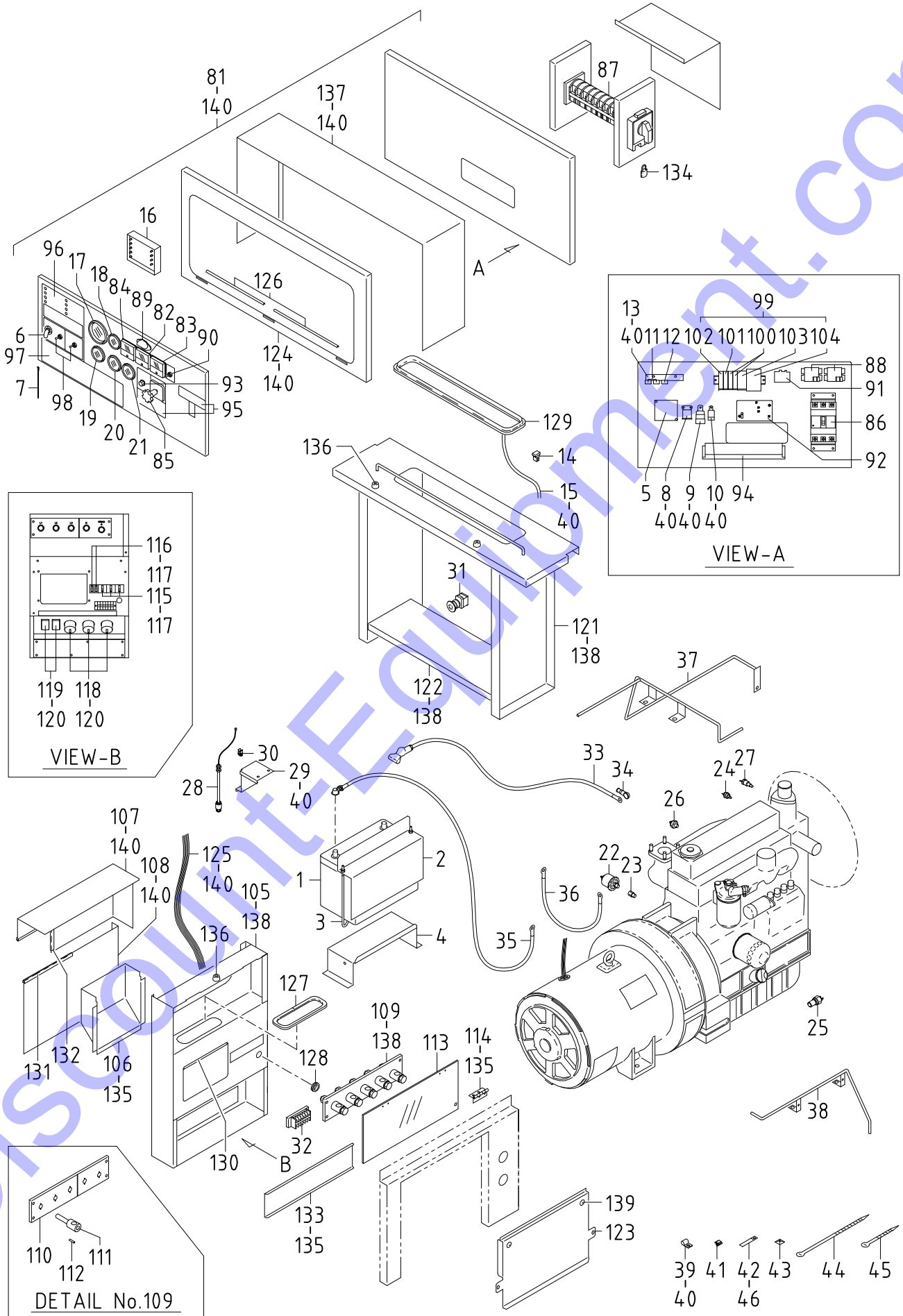

44 - 00 ELECTRIC

Ref. NO.	Part NO.	Inter-change ability	Part Name	Q'ty	C/H	Remarks	Ref. NO.	Part NO.	Inter-change ability	Part Name	Q'ty	C/H	Remarks
44 - 00 ELECTRIC GROUP							46 - 00 ELECTRIC GROUP						
1	44210 06700		Battery	1		(95D31R)	81	46900 98500		Switch board ass'y	1		Const. No. 82~104
2	44220 24500		Cover	1				02247 06025		Bolt, w/w	4		(for cover)
3	44243 04501		Holder	2				45214 01400		Washer	4		(for cover)
	02915 00008		Hexagon flange nut	2			82	46153 04000		Voltmeter (AC)	1		
4	44100 09500		Battery box	1			83	46154 14500		Ammeter (AC)	1		
	02201 06016		Flange bolt	4			84	46911 01400		Frequency meter	1		
5	44390 03300		Controller	1		(KUBOTA 1K951-60601)	85	46913 01000		Transfer device	1		
	02138 06055		Bolt	2			86	46120 30200		Circuit breaker	1		
	03115 02006		Spring washer	2			87	46917 01200		Change device,	1		
	03116 12006		Plain washer	2						voltage			
6	44322 07200		Starter switch	1		(KUBOTA 17422-63591)		02305 65040		Screw	4		
	52739 00600		Key	2				02345 65020		Screw	4		
7	52660 04700		Hook	1				02912 08005		Nut	8		
	03260 03010		Blind rivet	1				03115 02005		Spring washer	8		
8	44346 13200		Relay (main)	1		(KUBOTA 68881-53542)		03116 12005		Plain washer	16		
9	44346 15200		Relay (glow)	1		(KUBOTA 3H300-75211)	88	46923 04500		Current transformer	2		
10	44346 15300		Relay (starter)	1		(KUBOTA 68881-53542)	89	46929 01200		Illuminator	1		
11	44470 01600		Fuse box	2				46939 01300		Bulb	1		
	46934 03200		Fuse (10A)	2			90	46167 02400		Select switch	1		
12	44470 02100		Fuse box	1			91	46928 01500		Thermal relay	1		
	46934 05000		Fuse (5A)	1			92	46950 02600		A. V. R ass'y	1		
13	44250 14710		Bracket	1			93	46918 01400		Controller	1		
14	44470 02300		Fuse box (60A)	1		(KUBOTA 52794-42421)		46991 00100		Knob	1		
15	44490 85830		Wiring harness	1			94	44311 51300		Terminal plate	1		
16	46870 55800		Controller	1		(Emergency)		46311 02200		Plate	1		
17	36146 08800		Tachometer	1			95	39178 50820		Plate (caution, switch)	1		
18	36158 00500		Gauge, fuel	1			96	39178 64330		Plate (warning, electric)	1		
19	36143 03600		Gauge, oil press.	1			97	39153 64900		Plate (notice)	1		
20	36145 06500		Thermometer, water	1			98	44500 03500		Switch panel ass'y	1		
21	46154 15300		Ammeter	1			99	46760 46210		Control panel	1		Const. No. 100~104
22	44365 00300		Oil pressure sender	1			100	46177 08300		Relay	2		
23	37189 34300		Bush	1			101	46177 08400		Relay	1		
24	44364 06200		Thermo sensor	1		(KUBOTA 31351-32831)	102	46177 08500		Relay	1		
25	44381 04000		Tacho sensor	1		(KUBOTA 56713-42931)	103	46872 01300		Dc power supply	1		
26	44328 20500		Pressure switch	1		(KUBOTA 15841-39012)		46948 00900		Surge absorber	1		
27	44334 17700		Thermo switch	1		(KUBOTA 51601-37671)	104	46879 45800		Controller complete	1		
28	46813 08100		Level switch	1			105	46470 95000		Box	1		
29	43350 02200		Bracket	1			106	46480 47900		Cover	1		
30	37181 03300		Clip	1			107	44260 37400		Cover	1		
31	44336 03001		Button switch	1			108	44260 37801		Cover	1		
32	44311 65600		Terminal plate	1			109	44311 66300		Terminal plate	1		Const. No. 110~112
	02345 24020		Screw	2			110	46305 09300		Plate	1		
	03115 03004		Spring washer	2			111	46312 05100		Bolt	5		
	03116 18004		Plain washer	2				35208 04500		Bolt	5		
33	05085 21060		Cable	1		(batt. ~starter)		02912 03014		Nut	10		
	44462 06700		Insulator	1		(red)		03115 02014		Spring washer	15		
	05625 00018		Terminal	1				03116 14014		Plain washer	20		
	02915 00008		Hexagon flange nut	1			112	03316 03016		Pin	10		
	06540 15055		Corrugated tube	1			113	52416 27400		Window glass	1		
	02915 00008		Hexagon flange nut	1		(for starter)		52640 02400		Bolt	1		
34	44462 00800		Insulator	1				45214 01400		Washer	1		
35	07885 52060		Cable	1		(batt. ~Eng. earth)	114	52480 13300		Hinge	2		
						(earth)		02915 00006		Hexagon flange nut	8		
36	05068 23070		Cable	1		(for frame)	115	46120 26900	Y	Circuit breaker	3		
	02201 08020		Flange bolt	1		(for Eng.)	115	46120 34000	Y	Circuit breaker	3		
	02108 12025		Bolt	1		(for Eng.)	116	46120 26800	Y	Circuit breaker	2		
	03115 02012		Spring washer	1		(for Eng.)	116	46120 34100	Y	Circuit breaker	2		
	03116 12012		Plain washer	1		(for Eng.)	117	02345 23008		Screw	16		
37	44290 48000		Guide	1				03115 03003		Spring washer	16		
	02108 12025		Bolt	2				03116 18003		Plain washer	16		
	03115 02012		Spring washer	2			118	44312 02800		Socket	3		
	03116 12012		Plain washer	2			119	44312 02900		Socket	2		
38	44290 48100		Guide	1			120	02345 24020		Screw	10		
	02108 10020		Bolt	2				02912 09004		Nut	10		
	03115 02010		Spring washer	2				03115 03004		Spring washer	10		
	03116 12010		Plain washer	2				03116 18004		Plain washer	20		
39	37181 06500		Clip	1			121	52350 72020		Cover	1		
40	02201 06016		Flange bolt	10			122	52350 44720		Cover	1		
41	44243 05500		Holder	4			123	52400 15720		Side cover	1		
42	03424 80101		Clip	3				02136 08035		Bolt	1		(side)
	02915 00008		Hexagon flange nut	1		(for thermo sensor)		02912 08008		Nut	4		(side)
43	44243 04600		Holder	1				GH245 00600		Washer	8		(side)
44	03425 00003		Vinyl clip	3				03116 12008		Plain washer	2		(side)
45	03425 00001		Vinyl clip	22				02246 08016		Bolt, w/w	2		(front)
46	02201 08012		Flange bolt	3			124	36120 19701		Plate	1		

44 - 00 ELECTRIC

Ref. NO.	Part NO.	Inter-change ability	Part Name	Q' ty	C/H	Remarks	Ref. NO.	Part NO.	Inter-change ability	Part Name	Q' ty	C/H	Remarks
125	44550 34000		Cable kit	1									
126	03407 66716		Seal rubber	1									
127	03407 66505		Seal rubber	1									
128	03403 00252		Grommet	1									
129	03407 64703		Seal rubber	1									
130	03407 66512		Seal rubber	1									
131	03407 66510		Seal rubber	1									
132	03407 66507		Seal rubber	1									
133	46480 55600		Bracket	1									
134	52723 00100		Lock ass'y	1		(w. key)							
135	02401 26016		Screw	18									
136	31131 04100		Rubber, vibration isolator	3									
137	46480 57200		Plate	1									
138	02201 08020		Flange bolt	16									
139	03403 10010		Grommet	2									
140	02201 06016		Flange bolt	31									

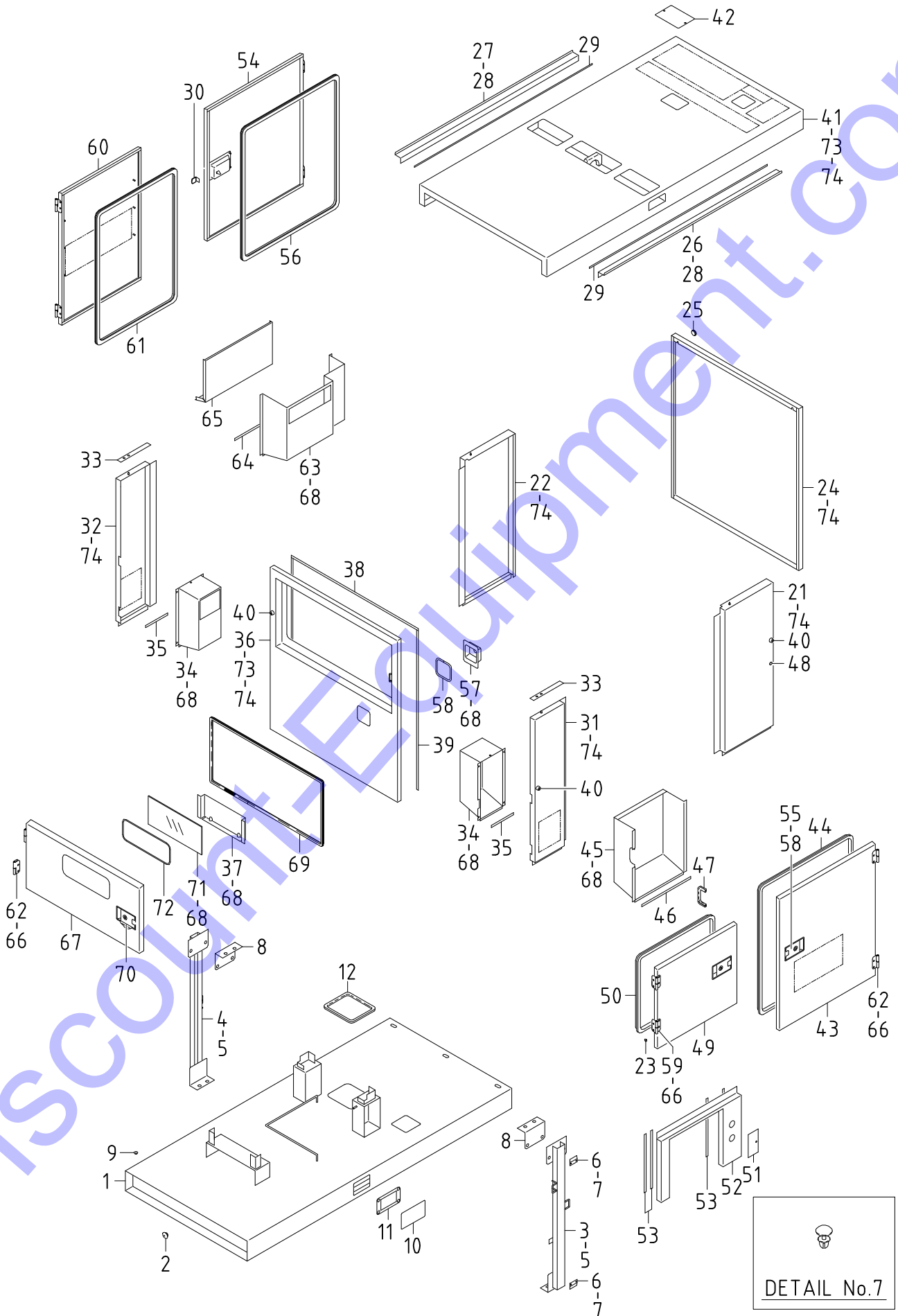

51 - 00 FRAME & BONNET

Ref. NO.	Part NO.	Inter-change ability	Part Name	Q' ty	C/H	Remarks	Ref. NO.	Part NO.	Inter-change ability	Part Name	Q' ty	C/H	Remarks
51 - 00 FRAME GROUP													
1	51100 33341		Frame	1			58	03407 67611		Seal rubber	1		
2	03403 10017		Grommet	4			59	52480 14400		Hinge	4		
3	52620 48000		Lifting bail	1			60	52450 04832		Door	1		
4	52620 47600		Lifting bail	1			61	03407 64720		Seal rubber	1		
5	02135 16040		Bolt	8			62	52480 13800		Hinge	6		
	03115 02016		Spring washer	8			63	52370 66101		Duct	1		
	03116 12016		Plain washer	12			64	03407 66856		Seal rubber	1		
	02912 08016		Nut	4			65	52370 65801		Duct	1		
6	52728 20810		Cushion rubber	4				52640 05100		Bolt	6		
7	52746 02400		Cap	8			66	02136 08016		Bolt	40		
	03116 35005		Plain washer	8			67	52450 04930		Door	1		
8	52630 12300		Stay	2			68	02915 00006		Hexagon flange nut	40		
	02135 16040		Bolt	4			69	03407 64740		Seal rubber	1		
	03115 06016		Spring washer	4			70	52728 14810		Cushion rubber	1		
	03116 15016		Plain washer	4			71	52416 19800		Window glass	1		
9	03403 10014		Grommet	3			72	03407 67605		Seal rubber	1		
10	52350 44421		Cover	2			73	02201 06016		Flange bolt	8		
	02201 06016		Flange bolt	9			74	02201 08020		Flange bolt	21		
11	52728 32010		Cushion rubber	2									
12	03407 64717		Seal rubber	1									
52 - 00 BONNET GROUP													
21	52100 94621		Cover	1									
22	52100 94720		Cover	1									
23	03403 10010		Grommet	14									
24	52830 41100		Cover	1									
25	52746 02100		Cap	2									
26	52160 40700		Bracket	1									
27	52160 41800		Bracket	1									
28	02401 46012		Screw	10									
29	03407 68144		Seal rubber	2									
30	52160 34600		Bracket	1									
	02401 24012		Screw	2									
	52746 01900		Cap (protector)	1									
31	52100 94521		Cover	1									
	02401 26016		Screw	1									
32	52100 94421		Cover	1									
33	52728 17610		Cushion rubber	2									
34	52370 76800		Duct	2									
35	03407 66861		Seal rubber	2									
36	52100 87520		Cover	1									
	02246 08050		Bolt, w/w	2									
37	39200 04302		Tool box	1									
38	03407 66863		Seal rubber	1									
39	03407 66848		Seal rubber	2									
40	31131 04100		Rubber, vibration isolator	5									
41	52300 29220		Top cover	1									
42	52350 89010		Cover	1									
	02246 08016		Bolt, w/w	2									
43	52450 27130		Door	1									
44	03407 64751		Seal rubber	1									
45	52370 79900		Duct	1									
46	03407 66855		Seal rubber	1									
47	03407 65710		Seal rubber	1									
48	52746 02700		Cap	1									
49	52450 11531		Door	1									
50	03407 64746		Seal rubber	1									
51	52350 41920		Cover	1									
	02401 45016		Screw	4									
	02915 00005		Hexagon flange nut	4									
52	52160 57200		Bracket	1									
	02401 46020		Screw	4									
	02136 06060		Bolt	2									
	03115 06006		Spring washer	2									
	03116 15006		Plain washer	2									
53	03407 66819		Seal rubber	4									
54	52450 11631		Door	1									
55	52710 03601		Latch ass'y	4									
	52739 03400		Key (0200)	4									
56	03407 64745		Seal rubber	1									
57	52230 44800		Cover	1									

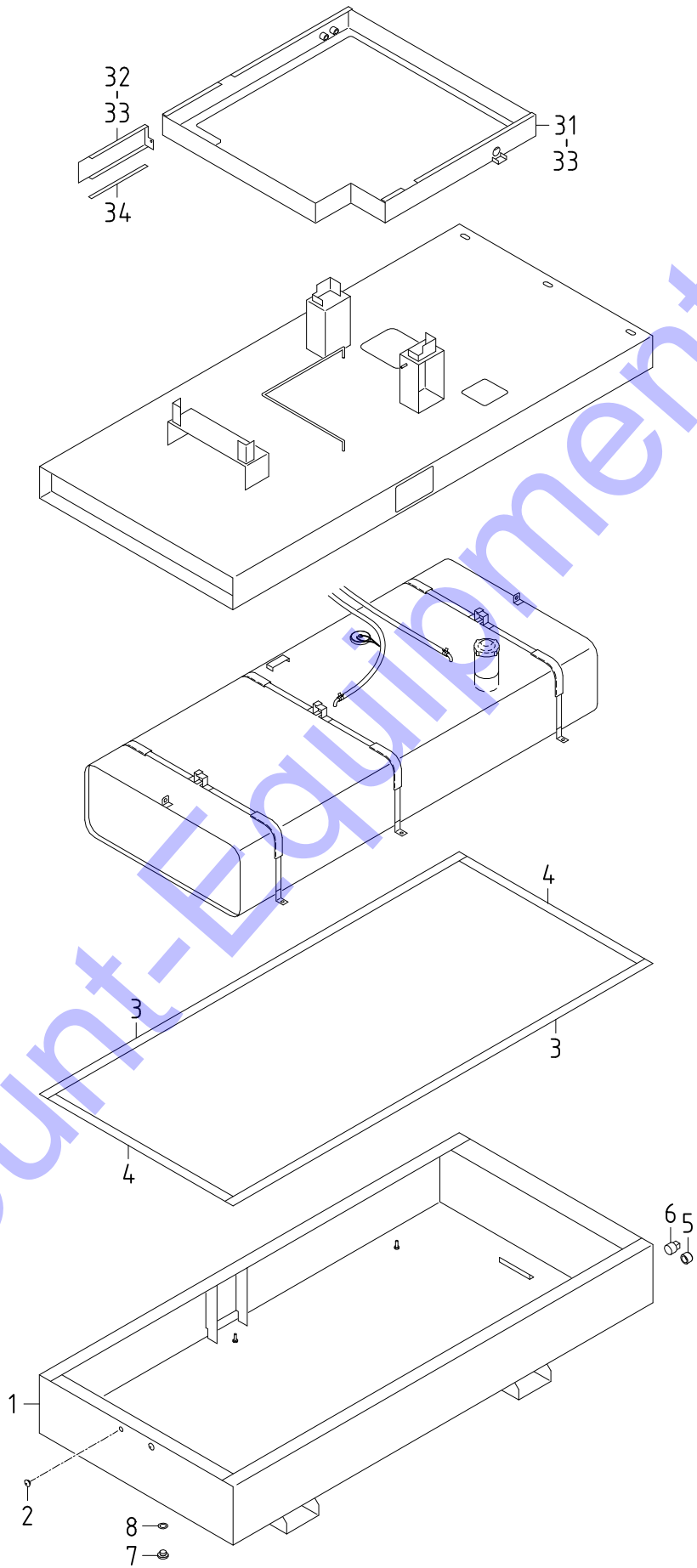

51 - 01 OIL FENCE

Ref. NO.	Part NO.	Inter-change ability	Part Name	Q' ty	C/H	Remarks	Ref. NO.	Part NO.	Inter-change ability	Part Name	Q' ty	C/H	Remarks
51 - 01 FRAME GROUP													
1	51100 12741		Frame	1									
	02473 12025		Stud bolt	6									
	52744 01400		Washer	6									
	02914 20012		Cap nut	6									
	03115 02012		Spring washer	6									
	03116 12012		Plain washer	6									
2	03403 10017		Grommet	4									
3	52728 33511		Cushion rubber	2									
4	52728 32711		Cushion rubber	2									
5	03731 60006		Cap	1									
6	03620 41008		Plug	1									
7	03620 20022		Plug	1									
8	03407 20122		Gasket	1									
52 - 01 BONNET GROUP													
31	52160 60600		Bracket	1									
	03260 05013		Blind rivet	20									
32	52160 60500		Bracket	1									
33	02201 06016		Flange bolt	4									
34	03407 66833		Seal rubber	1									

52 - 00 LINING

Ref. NO.	Part NO.	Inter-change ability	Part Name	Q'ty	C/H	Remarks	Ref. NO.	Part NO.	Inter-change ability	Part Name	Q'ty	C/H	Remarks
	52900 00820		URETHANE FOAM KIT			Const. No. 1~9							
	52901 00820		URETHANE FOAM KIT			Const. No. 101~108							
1	52931 74020		Lining	1									
2	52959 97730		Lining	2									
3	52959 48250		Lining	1									
4	52959 48350		Lining	1									
5	52959 77830		Lining	1									
6	52959 38350		Lining	2									
7	52959 95740		Lining	2									
8	52919 02230		Lining	1									
9	52919 56920		Lining	2									
101	52977 21900		Lining	2									
102	52978 15400		Lining	1									
103	52978 09900		Lining	1									
104	52977 34900		Lining	1									
105	52977 12800		Lining	1									
106	52977 34300		Lining	2									
107	52977 34400		Lining	1									
108	52977 34500		Lining	1									

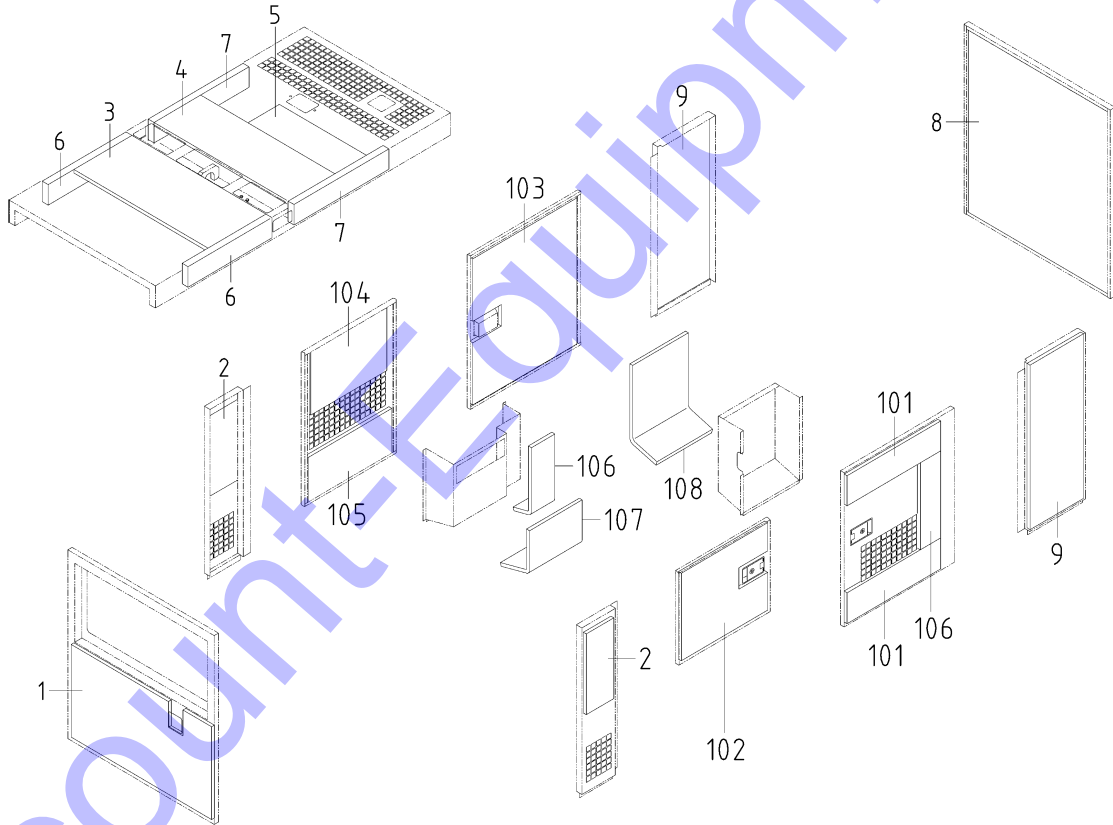

I N D E X

PART NO.	PAGE	REF. NO.	PART NO.	PAGE	REF. NO.	PART NO.	PAGE	REF. NO.			
02108	10020	44 - 2	38	02401	26016	44 - 3	135	03116	12003	20 - 2	5
02108	12025	20 - 2	25	02401	26016	51 - 2	31	03116	12005	44 - 2	87
02108	12025	38 - 2	73	02401	45016	51 - 2	51	03116	12006	20 - 2	6
02108	12025	44 - 2	36	02401	46012	51 - 2	28	03116	12006	20 - 2	8
02108	12025	44 - 2	37	02401	46020	51 - 2	52	03116	12006	44 - 2	5
02135	10040	20 - 2	1	02415	65012	43 - 2	2	03116	12008	44 - 2	123
02135	16040	51 - 2	5	02473	12025	51 - 4	1	03116	12010	43 - 2	7
02135	16040	51 - 2	8	02912	03014	44 - 2	111	03116	12010	44 - 2	38
02136	06060	51 - 2	52	02912	06010	38 - 2	102	03116	12012	38 - 2	73
02136	08016	51 - 2	66	02912	08005	44 - 2	87	03116	12012	44 - 2	36
02136	08035	44 - 2	123	02912	08006	20 - 2	6	03116	12012	44 - 2	37
02136	10035	38 - 2	102	02912	08008	44 - 2	123	03116	12012	51 - 4	1
02138	06040	20 - 2	8	02912	08010	43 - 2	7	03116	12016	51 - 2	5
02138	06055	44 - 2	5	02912	08016	51 - 2	5	03116	14014	44 - 2	111
02138	08030	20 - 2	10	02912	09004	44 - 2	120	03116	15006	51 - 2	52
02138	10016	20 - 2	8	02914	20012	51 - 4	1	03116	15010	38 - 2	102
02138	10070	43 - 2	7	02915	00005	51 - 2	51	03116	15016	51 - 2	8
02201	06016	38 - 2	26	02915	00006	38 - 2	27	03116	18003	44 - 2	117
02201	06016	38 - 2	68	02915	00006	44 - 2	114	03116	18004	44 - 2	32
02201	06016	43 - 2	18	02915	00006	51 - 2	68	03116	18004	44 - 2	120
02201	06016	44 - 2	4	02915	00008	38 - 2	106	03116	35005	51 - 2	7
02201	06016	44 - 2	40	02915	00008	43 - 2	8	03260	03010	39 - 2	2
02201	06016	44 - 3	140	02915	00008	44 - 2	3	03260	03010	44 - 2	7
02201	06016	51 - 2	10	02915	00008	44 - 2	33	03260	05013	51 - 4	31
02201	06016	51 - 2	73	02915	00008	44 - 2	33	03316	03016	44 - 2	112
02201	06016	51 - 4	33	02915	00008	44 - 2	42	03403	00252	44 - 3	128
02201	08012	20 - 2	41	02915	11010	38 - 2	102	03403	00303	38 - 2	15
02201	08012	38 - 2	1	02915	20012	20 - 2	21	03403	00512	38 - 2	16
02201	08012	43 - 2	15	03115	02003	20 - 2	5	03403	00703	38 - 2	17
02201	08012	44 - 2	46	03115	02005	44 - 2	87	03403	10010	44 - 3	139
02201	08020	38 - 2	105	03115	02006	20 - 2	6	03403	10010	51 - 2	23
02201	08020	44 - 2	36	03115	02006	20 - 2	8	03403	10014	51 - 2	9
02201	08020	44 - 3	138	03115	02006	44 - 2	5	03403	10017	51 - 2	2
02201	08020	51 - 2	74	03115	02008	20 - 2	10	03403	10017	51 - 4	2
02201	08070	43 - 2	14	03115	02010	20 - 2	1	03407	16024	38 - 2	62
02201	10020	38 - 2	6	03115	02010	43 - 2	7	03407	20122	51 - 4	8
02201	10020	38 - 2	101	03115	02010	44 - 2	38	03407	64703	44 - 3	129
02238	10030	20 - 2	1	03115	02012	20 - 2	25	03407	64717	51 - 2	12
02246	08016	44 - 2	123	03115	02012	38 - 2	73	03407	64720	51 - 2	61
02246	08016	51 - 2	42	03115	02012	44 - 2	36	03407	64740	51 - 2	69
02246	08050	51 - 2	36	03115	02012	44 - 2	37	03407	64745	51 - 2	56
02247	06025	44 - 2	81	03115	02012	51 - 4	1	03407	64746	51 - 2	50
02248	06025	20 - 2	9	03115	02014	44 - 2	111	03407	64751	51 - 2	44
02305	65040	44 - 2	87	03115	02016	51 - 2	5	03407	65710	51 - 2	47
02345	23008	44 - 2	117	03115	03003	44 - 2	117	03407	66505	44 - 3	127
02345	24020	44 - 2	32	03115	03004	44 - 2	32	03407	66507	44 - 3	132
02345	24020	44 - 2	120	03115	03004	44 - 2	120	03407	66510	44 - 3	131
02345	63012	20 - 2	5	03115	06006	51 - 2	52	03407	66512	44 - 3	130
02345	65020	44 - 2	87	03115	06010	38 - 2	102	03407	66716	44 - 3	126
02401	24012	51 - 2	30	03115	06016	51 - 2	8	03407	66819	51 - 2	53

I N D E X

PART NO.	PAGE	REF. NO.	PART NO.	PAGE	REF. NO.	PART NO.	PAGE	REF. NO.
03407 66833	51 - 4	34	05085 21060	44 - 2	33	38465 12600	43 - 2	3
03407 66848	51 - 2	39	05625 00018	44 - 2	33	38469 01400	38 - 2	1
03407 66855	51 - 2	46	06540 15055	44 - 2	33	38524 68000	38 - 2	3
03407 66856	51 - 2	64	07885 52060	44 - 2	35	38524 68100	38 - 2	2
03407 66861	51 - 2	35	20003 57603	20 - 2	1	38590 01200	38 - 2	23
03407 66863	51 - 2	38	21472 15700	20 - 2	11	38591 01000	38 - 2	25
03407 66933	38 - 2	12	25100 09101	20 - 2	2	38594 02000	38 - 2	7
03407 66939	38 - 2	14	25200 11100	20 - 2	7	38594 02900	38 - 2	71
03407 66952	38 - 2	13	25310 09600	20 - 2	10	38594 03100	38 - 2	10
03407 67311	38 - 2	9	25360 07100	20 - 2	9	38594 05000	38 - 2	11
03407 67605	51 - 2	72	25650 01800	20 - 2	3	39103 46801	39 - 2	2
03407 67611	51 - 2	58	25651 00300	20 - 2	4	39152 23401	39 - 2	20
03407 68144	51 - 2	29	25660 02400	20 - 2	6	39153 64900	44 - 2	97
03424 80101	44 - 2	42	25700 07600	20 - 2	8	39170 02000	39 - 2	1
03424 80218	38 - 2	6	31110 02610	20 - 2	23	39173 02000	39 - 2	15
03425 00001	38 - 2	30	31110 02710	20 - 2	24	39173 03300	39 - 2	32
03425 00001	44 - 2	45	31120 08900	20 - 2	22	39176 05010	39 - 2	13
03425 00003	43 - 2	32	31131 04100	44 - 3	136	39176 50000	39 - 2	27
03425 00003	44 - 2	44	31131 04100	51 - 2	40	39176 62400	39 - 2	14
03511 10017	43 - 2	31	32100 40700	20 - 2	41	39176 62900	39 - 2	21
03511 20016	43 - 2	31	32142 08600	20 - 2	43	39176 69300	39 - 2	29
03511 20020	43 - 2	11	32143 11700	20 - 2	42	39176 69500	39 - 2	25
03511 20035	38 - 2	65	32148 03000	20 - 2	45	39176 69600	39 - 2	26
03511 20060	38 - 2	4	32151 01400	20 - 2	44	39176 73300	39 - 2	22
03511 20070	38 - 2	5	32331 79000	20 - 2	46	39176 73500	39 - 2	23
03511 20080	20 - 2	47	35208 04500	44 - 2	111	39176 73800	39 - 2	24
03511 30185	38 - 2	24	35483 10101	43 - 2	17	39176 85800	39 - 2	16
03511 40016	38 - 2	28	36120 19701	44 - 2	124	39176 85900	39 - 2	17
03511 40016	38 - 2	72	36143 03600	44 - 2	19	39178 00310	39 - 2	31
03511 40016	43 - 2	30	36145 06500	44 - 2	20	39178 22030	39 - 2	28
03511 40020	43 - 2	29	36146 08800	44 - 2	17	39178 43110	39 - 2	11
03570 08042	43 - 2	25	36158 00500	44 - 2	18	39178 47610	39 - 2	12
03570 08207	43 - 2	26	36159 03000	43 - 2	2	39178 49120	39 - 2	30
03570 09028	43 - 2	11	37170 02900	38 - 2	66	39178 50620	39 - 2	19
03580 19055	38 - 2	64	37170 12200	43 - 2	21	39178 50820	44 - 2	95
03600 08071	43 - 2	24	37170 12700	43 - 2	10	39178 53620	39 - 2	8
03600 08182	43 - 2	23	37170 20100	38 - 2	68	39178 54721	39 - 2	6
03600 09008	43 - 2	28	37170 20200	43 - 2	12	39178 54820	39 - 2	7
03600 09040	43 - 2	27	37181 03300	44 - 2	30	39178 57720	39 - 2	5
03600 09100	43 - 2	22	37181 05000	38 - 2	73	39178 61430	39 - 2	3
03620 20022	51 - 4	7	37181 06500	44 - 2	39	39178 61530	39 - 2	4
03620 41003	43 - 2	13	37181 07300	43 - 2	16	39178 63830	39 - 2	10
03620 41004	38 - 2	70	37189 34300	44 - 2	23	39178 64330	44 - 2	96
03620 41008	51 - 4	6	38100 40400	38 - 2	1	39178 80820	39 - 2	9
03731 21003	43 - 2	20	38410 05800	38 - 2	1	39178 87210	39 - 2	18
03731 60006	51 - 4	5	38440 02811	38 - 2	18	39178 90520	39 - 2	36
03734 43030	43 - 2	19	38440 02911	38 - 2	19	39178 90620	39 - 2	37
03735 13004	38 - 2	67	38450 80501	38 - 2	20	39189 21100	39 - 2	38
03830 08004	38 - 2	106	38450 81001	38 - 2	21	39189 21300	39 - 2	33
05068 23070	44 - 2	36	38450 81100	38 - 2	22	39189 21400	39 - 2	34

I N D E X

PART NO.	PAGE	REF. NO.	PART NO.	PAGE	REF. NO.	PART NO.	PAGE	REF. NO.			
39189	21500	39 - 2	35	44470	02300	44 - 2	14	52100	94621	51 - 2	21
39200	04302	51 - 2	37	44490	85830	44 - 2	15	52100	94720	51 - 2	22
42100	79400	38 - 2	101	44500	03500	44 - 2	98	52160	34600	51 - 2	30
42240	28201	38 - 2	105	44550	34000	44 - 3	125	52160	40700	51 - 2	26
42310	97200	38 - 2	102	45214	01400	44 - 2	81	52160	41800	51 - 2	27
42324	13600	38 - 2	104	45214	01400	44 - 2	113	52160	57200	51 - 2	52
42324	15200	38 - 2	103	46120	26800	44 - 2	116	52160	60500	51 - 4	32
43100	70102	43 - 2	1	46120	26900	44 - 2	115	52160	60600	51 - 4	31
43210	01301	43 - 2	4	46120	30200	44 - 2	86	52230	44800	51 - 2	57
43220	01300	43 - 2	5	46120	34000	44 - 2	115	52300	29220	51 - 2	41
43310	27200	43 - 2	6	46120	34100	44 - 2	116	52350	41920	51 - 2	51
43310	27300	43 - 2	7	46153	04000	44 - 2	82	52350	44421	51 - 2	10
43322	06700	43 - 2	9	46154	14500	44 - 2	83	52350	44720	44 - 2	122
43350	02200	44 - 2	29	46154	15300	44 - 2	21	52350	70821	38 - 2	8
43532	09400	38 - 2	63	46167	02400	44 - 2	90	52350	72020	44 - 2	121
43534	02102	38 - 2	61	46177	08300	44 - 2	100	52350	89010	51 - 2	42
43550	03100	43 - 2	14	46177	08400	44 - 2	101	52370	65801	51 - 2	65
43650	02400	43 - 2	15	46177	08500	44 - 2	102	52370	66101	51 - 2	63
44100	09500	44 - 2	4	46305	09300	44 - 2	110	52370	76800	51 - 2	34
44210	06700	44 - 2	1	46311	02200	44 - 2	94	52370	79900	51 - 2	45
44220	24500	44 - 2	2	46312	05100	44 - 2	111	52400	15720	44 - 2	123
44243	04501	44 - 2	3	46470	95000	44 - 2	105	52416	19800	51 - 2	71
44243	04600	44 - 2	43	46480	47900	44 - 2	106	52416	27400	44 - 2	113
44243	05500	38 - 2	29	46480	55600	44 - 3	133	52450	04832	51 - 2	60
44243	05500	44 - 2	41	46480	57200	44 - 3	137	52450	04930	51 - 2	67
44250	14710	44 - 2	13	46760	46210	44 - 2	99	52450	11531	51 - 2	49
44260	37400	44 - 2	107	46813	08100	44 - 2	28	52450	11631	51 - 2	54
44260	37801	44 - 2	108	46870	55800	44 - 2	16	52450	27130	51 - 2	43
44290	48000	44 - 2	37	46872	01300	44 - 2	103	52480	13300	44 - 2	114
44290	48100	44 - 2	38	46879	45800	44 - 2	104	52480	13800	51 - 2	62
44311	51300	44 - 2	94	46900	98500	44 - 2	81	52480	14400	51 - 2	59
44311	65600	44 - 2	32	46911	01400	44 - 2	84	52620	47600	51 - 2	4
44311	66300	44 - 2	109	46913	01000	44 - 2	85	52620	48000	51 - 2	3
44312	02800	44 - 2	118	46917	01200	44 - 2	87	52630	12300	51 - 2	8
44312	02900	44 - 2	119	46918	01400	44 - 2	93	52640	02400	44 - 2	113
44322	07200	44 - 2	6	46921	08800	20 - 2	5	52640	05100	51 - 2	65
44328	20500	44 - 2	26	46923	04500	44 - 2	88	52660	04700	44 - 2	7
44334	17700	44 - 2	27	46928	01500	44 - 2	91	52710	03601	51 - 2	55
44336	03001	44 - 2	31	46929	01200	44 - 2	89	52723	00100	44 - 3	134
44346	13200	44 - 2	8	46934	03200	44 - 2	11	52728	14810	51 - 2	70
44346	15200	44 - 2	9	46934	05000	44 - 2	12	52728	15710	38 - 2	69
44346	15300	44 - 2	10	46939	01300	44 - 2	89	52728	17610	51 - 2	33
44364	06200	44 - 2	24	46948	00900	44 - 2	103	52728	20810	51 - 2	6
44365	00300	44 - 2	22	46950	02600	44 - 2	92	52728	32010	51 - 2	11
44381	04000	44 - 2	25	46991	00100	44 - 2	93	52728	32711	51 - 4	4
44390	03300	44 - 2	5	51100	12741	51 - 4	1	52728	33511	51 - 4	3
44462	00800	44 - 2	34	51100	33341	51 - 2	1	52739	00600	44 - 2	6
44462	06700	44 - 2	33	52100	87520	51 - 2	36	52739	03400	51 - 2	55
44470	01600	44 - 2	11	52100	94421	51 - 2	32	52744	01400	51 - 4	1
44470	02100	44 - 2	12	52100	94521	51 - 2	31	52746	01900	51 - 2	30

I N D E X

PART NO.	PAGE	REF. NO.	PART NO.	PAGE	REF. NO.	PART NO.	PAGE	REF. NO.
52746 02100	51 - 2	25						
52746 02400	51 - 2	7						
52746 02700	51 - 2	48						
52830 41100	51 - 2	24						
52919 02230	52 - 1	8						
52919 56920	52 - 1	9						
52931 74020	52 - 1	1						
52959 38350	52 - 1	6						
52959 48250	52 - 1	3						
52959 48350	52 - 1	4						
52959 77830	52 - 1	5						
52959 95740	52 - 1	7						
52959 97730	52 - 1	2						
52977 12800	52 - 1	105						
52977 21900	52 - 1	101						
52977 34300	52 - 1	106						
52977 34400	52 - 1	107						
52977 34500	52 - 1	108						
52977 34900	52 - 1	104						
52978 09900	52 - 1	103						
52978 15400	52 - 1	102						
GG160 00100	20 - 2	21						
GH245 00600	44 - 2	123						

Discount-Equipment.com



AIRMAN
HOKUETSU INDUSTRIES CO., LTD.

Discount Equipment

Discount-Equipment.com is your online resource for commercial and industrial quality parts and equipment sales.

Locations:

Florida (West Palm Beach): [561-964-4949](tel:561-964-4949)

Outside Florida TOLL FREE: [877-690-3101](tel:877-690-3101)

Need parts? Check out our website at www.discount-equipment.com

Can't find what you need?

Click on this link: <http://www.discount-equipment.com/category/5443-parts/> and fill out the request form.

Please have the machine model and serial number available in order to help us get you the correct parts. One of our experienced staff members will get back to you with a quote for the right part that your machine needs.

We sell worldwide for the brands: Genie, Terex, JLG, MultiQuip, Mayco, Toro/Stone, Diamond Products, Magnum, Airman, Mustang, Power Blanket, Nifty Lift, Atlas Copco, Chicago Pneumatic, Allmand Brothers, Essick, Miller Spreader, Skyjack, Lull, Skytrak, Tsurumi, Husquvarna/Target, Whiteman-Concrete/Mortar, Stow-Concrete/Mortar, Baldor, Wacker, Sakai, Snorkel, Upright, Mi-T-M, Sullair, Neal, Basic, Dynapac, MBW, Weber, Bartell, Bennar Newman, Haulotte, Ditch Runner, Blaw-Knox, Himoina, Best, Buddy, Crown, Edco, Wyco, Bomag, Laymor, Terremite, Barreto, EZ Trench, Takeuchi, Basic, Bil-Jax, Curtis, Gehl, Heli, Honda, ICS/PowerGrit, Puckett, Waldon, ASV, IHI, Partner, Imer, Clipper, MMD, Koshin, Rice, Gorman Rupp, CH&E, Cat Pumps, Comet, General Pump, Giant, AMida, Coleman, NAC, Gradall, Square Shooter, Kent, Stanley, Tamco, Toku, Hatz, Kohler, Robin, Wisconsin, Northrock, Oztec, Toker TK, Rol-Air, Small Line, Wanco, Yanmar

New Equipment - Used Equipment - Rental Equipment - Parts and Accessories

Discount Equipment

www.discount-equipment.com

561-964-4949

Parts: wbparts@Discount-Equipment.com

Sales: info@Discount-Equipment.com